



Z450 Z Master[®] With 48in TURBO FORCE[®] Side Discharge Mower

Model No. 74417 - 280000001 and up.

Parts Catalog

Ordering Replacement Parts

To order replacement parts, please supply the part number, the quantity, and the description of each part desired.

Understanding Reference Numbers

Each identified part in an illustration has a reference number. The reference number for a part also appears in the parts list, along with other information about the part.

This catalog uses two special reference number formats, one to indicate parts in a service assembly and another to indicate the quantity of a given part in an illustration.

Service Assembly Reference Numbers

Parts in service assemblies have reference numbers in the form a:b. The a represents the reference number of the entire service assembly and the b represents a sequential number unique to each part within the service assembly.

For example, a wheel assembly might be identified by reference number 6, the tire by 6:1, the valve by 6:2, and the wheel by 6:3. When you order the assembly identified by reference number 6, you receive all parts identified by reference numbers 6:1, 6:2, and 6:3. However, you may also order any part individually. Reference numbers of this type appear in illustrations and in part lists.

Reference Numbers Indicating Quantity

In an illustration, if a reference number indicates more than one part, the reference number has the form nX y. The n represents the quantity of the part, the X is the multiplication symbol, and the y represents the reference number.

For example, in an illustration, the reference number 2X 37 means that two of the parts identified by reference number 37 are indicated.

Contents

Description	Page	Description	Page
Front Frame Assembly 3	Roll-Over Protection System Assembly No. 107-8093 29
Caster Wheel Assembly No. 110-5745 4	Cylinder and Crankcase Assembly Kawasaki FH680V-DS21 30
Height-of-Cut Assembly 5	Piston and Crankshaft Assembly Kawasaki FH680V-DS21 31
Main Frame Assembly 6	Valve and Camshaft Assembly Kawasaki FH680V-DS21 32
Fuel System Assembly 7	Lubrication Equipment Assembly Kawasaki FH680V-DS21 33
Parking Brake Assembly 8	Cooling Equipment Assembly Kawasaki FH680V-DS21 34
Motion Control Assembly 9	Electric Equipment Assembly Kawasaki FH680V-DS21 35
RH Motion Control Assembly No. 109-3911 10	Control Equipment Assembly Kawasaki FH680V-DS21 36
LH Motion Control Assembly No. 109-3912 11	Carburetor Assembly Kawasaki FH680V-DS21 37
Hydraulic System Assembly 12	Air Filter and Muffler Assembly Kawasaki FH680V-DS21 38
Hydraulic Pump Assembly No. 103-1942 14	Fuel Tank and Valve Assembly Kawasaki FH680V-DS21 39
Pump Idler and Belt Assembly 15	Starter Assembly Kawasaki FH680V-DS21 40
Engine, Clutch and Muffler Assembly 16	Label Assembly Kawasaki FH680V-DS21 41
Deck Connection Assembly 17	Attachments and Accessories List 42
Deck Assembly 18		
Deck Decal Assembly No. 107-8515 20		
Spindle Assembly No. 107-8504 21		
Rubber Deflector Assembly No. 108-2792 22		
Idler Assembly 23		
Electrical System Assembly 24		
Seat and Bracket Assembly 26		
Seat and Bracket Assembly No. 110-0446 27		
Roll-Over Protection System Assembly 28		

Part Description Abbreviations

Part descriptions in this catalog may include the following abbreviations.

AR. as required	HYD. hydraulic
ASM. assembly	LH. left hand
BBC. blade brake clutch	NI. nylon insert
CARR. carriage	NPTF. national pipe thread fine
DEG. degrees	PFH. phillips flat head
EXT. external	PPH. phillips pan head
FH. flat head	PPHTF. phillips pan head thread forming
GA. gauge	PRH. phillips round head
HD. heavy-duty	PTH. phillips truss head
HF. hex flange	PTO. power-take-off
HH. hex head	RH. right hand
HHF. hex head flange	ROPS. roll-over protection system
HHFTF. hex head flange thread forming	SFH. slotted fillister head
HJ. hex jam	SHH. slotted hex head
HLH. hex lag head	SHWH. slotted hex washer head
HOC. height-of-cut	SPH. slotted pan head
HSBH. hex socket button head	SQH. square head
HSFH. hex socket flat head	SRH. slotted round head
HSH. hex socket head	STD. standard
HWH. hex washer head	TAP. self tapping
HWHTF. hex washer head thread forming	TTH. torx truss head

Footnotes

- | | |
|----------------------|--|
| ❶ Not illustrated | ❷ Not serviced separately |
| ❸ Optional Equipment | ❹ Obtain from your local Kawasaki dealer |

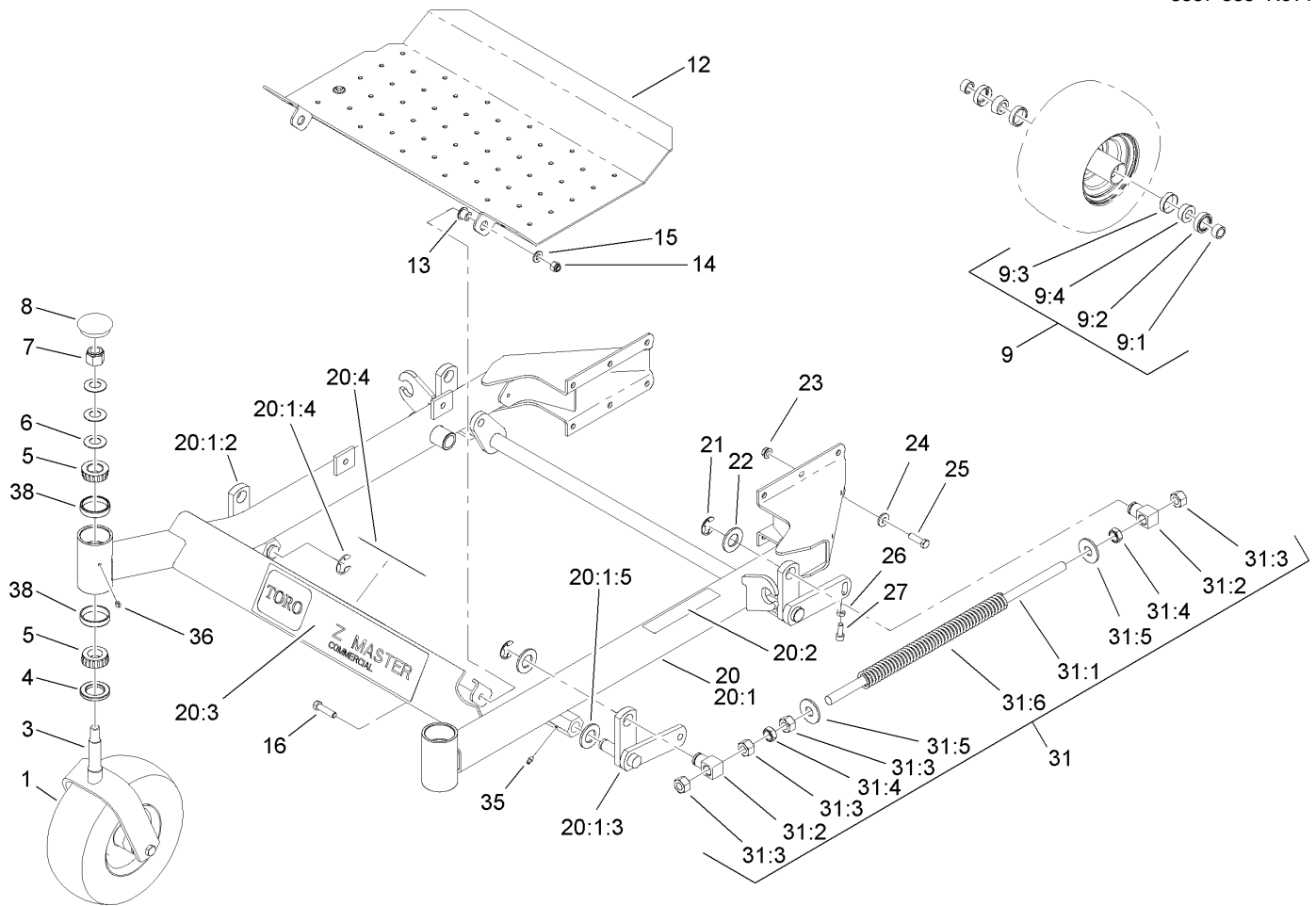

Front Frame Assembly

Ref	Part No.	Qty.	Description
1	110-5745	2	Semi Pnuematic Wheel ASM
3	1-632511-01	2	Caster
4	1-543511	2	Seal-Grease
5	254-94	4	Bearing-Cone, Tapered
6	1-633508	6	Washer-Bellville
7	3296-51	2	Nut-Lock, NI
8	103-4882	2	Cap-Grease
9	110-8837	1	Caster Wheel Bearing Kit
9:1	1-633581	2	Spacer-Bearing
9:2	1-633580	2	Seal-Bearing
9:3	1-633584	2	Bearing-Cup
9:4	1-633585	2	Bearing-Cone, Taper
12	108-5007-03	1	Floor Pan
13	86-2180	2	Bushing-Flange
14	3296-39	2	Nut-Lock, NI
15	3256-24	2	Washer-Flat
16	323-8	2	Screw-HH
20	108-5022	1	Front Frame ASM
20:1		1	Frame-Front
20:1:2	99-3872-01	1	RH Lift Arm ASM
20:1:3	99-3871-01	1	LH Lift Arm ASM
20:1:4	32151-103	2	Ring-Retaining, EXT
20:1:5	3256-29	2	Washer-Flat
20:2	1-633818	1	Decal-Warning

Ref	Part No.	Qty.	Description
20:3	106-7451	1	Decal
20:4	107-2112	1	Decal-Warning
21	32151-103	4	Ring-Retaining, EXT
22	3256-29	4	Washer-Flat
23	3290-357	12	Nut-HHF, Whiz
24	98-5975	12	Washer-Belleville
25	323-7	12	Screw-HH
26	3218-2	2	Nut-Jam
27	3274-18	2	Screw-HSH
31	1-634439	2	Front Frame Spring ASM
31:1	1-633096	1	Rod-Lift, Deck
31:2	1-633441	2	Swivel-Deck Mount, Rear
31:3	3217-11	4	Nut-Hex
31:4	3218-6	2	Nut-Jam
31:5	3256-7	2	Washer-Flat
31:6	1-633064	1	Spring-Support, Deck
35	302-19	4	Fitting-Grease
36	1-811010	2	Plug
38	254-72	4	Bearing-Cup, Tapered

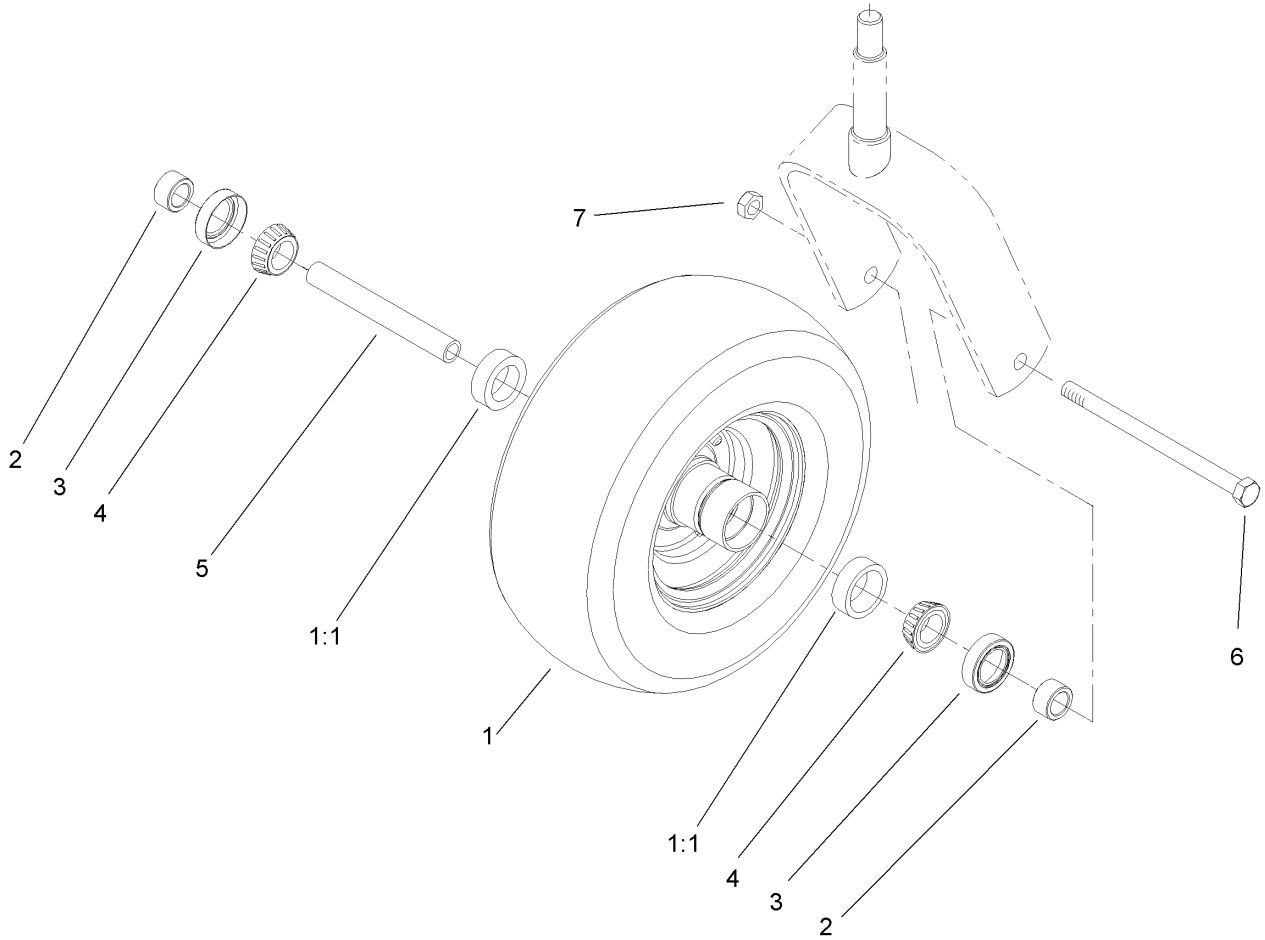

Caster Wheel Assembly No. 110-5745

Ref	Part No.	Qty.	Description
1	110-5743	1	Wheel And Tire ASM (Semi-Pneumatic)
1:1	1-633584	1	Bearing-Cup
2	1-633581	2	Spacer-Bearing
3	1-633580	2	Seal-Bearing
4	1-633585	2	Bearing-Cone, Taper
5	1-633579	1	Spacer-Caster, Front
6	325-36	1	Screw-HH
7	3296-45	1	Nut-Lock, NI

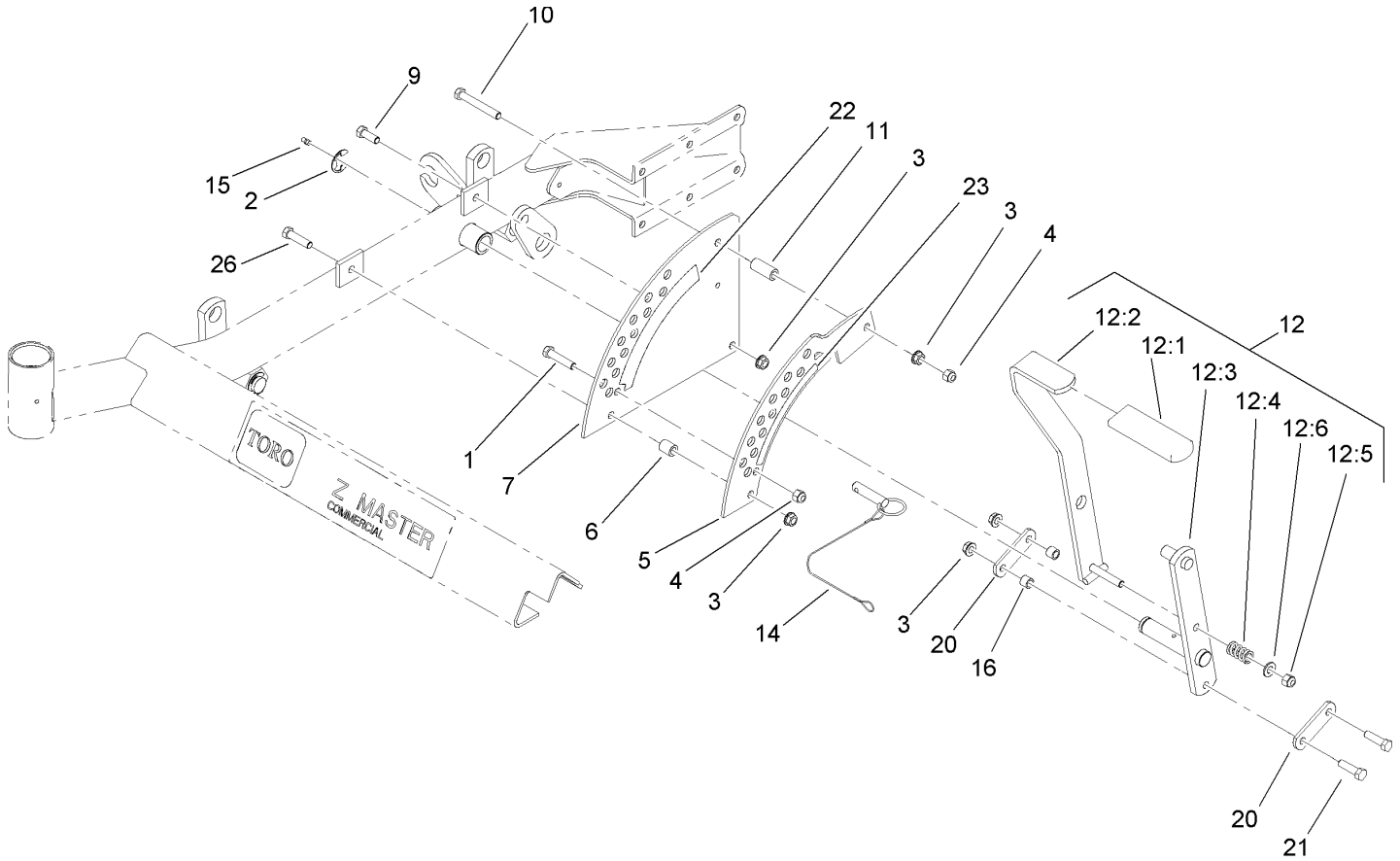

Height-of-Cut Assembly

Ref	Part No.	Qty.	Description
1	323-9	1	Screw-HH
2	32151-103	1	Ring-Retaining, EXT
3	3290-357	5	Nut-HHF, Whiz
4	3296-39	2	Nut-Lock, NI
5	108-7755-01	1	Plate-Lift, Deck
6	1-633080	1	Bushing-Lever, Lift
7	1-653230-01	1	Plate-Lift, Deck
9	323-6	1	Screw-HH
10	323-13	1	Screw-HH
11	1-633082	1	Bushing-Lever, Lift
12	110-5870	1	Deck Lift Handle ASM
12:1	1-633295	1	Grip-Lever, Lift
12:2	103-2078	1	Handle-Lift
12:3	106-6598	1	Lift Arm ASM
12:4	1-633325	1	Spring-Compression
12:5	3296-39	1	Nut-Lock, NI
12:6	3256-24	1	Washer-Flat
14	106-9951	1	Hitch Pin ASM
15	302-19	1	Fitting-Grease
16	103-1918	2	Bushing
20	1-633068	2	Arm-Lift, Deck
21	323-29	2	Screw-HH
22	108-1051	1	Decal-Deck Height, Outer
23	108-1050	1	Decal-Deck Height, Inner

Ref	Part No.	Qty.	Description
26	323-8	1	Screw-HH

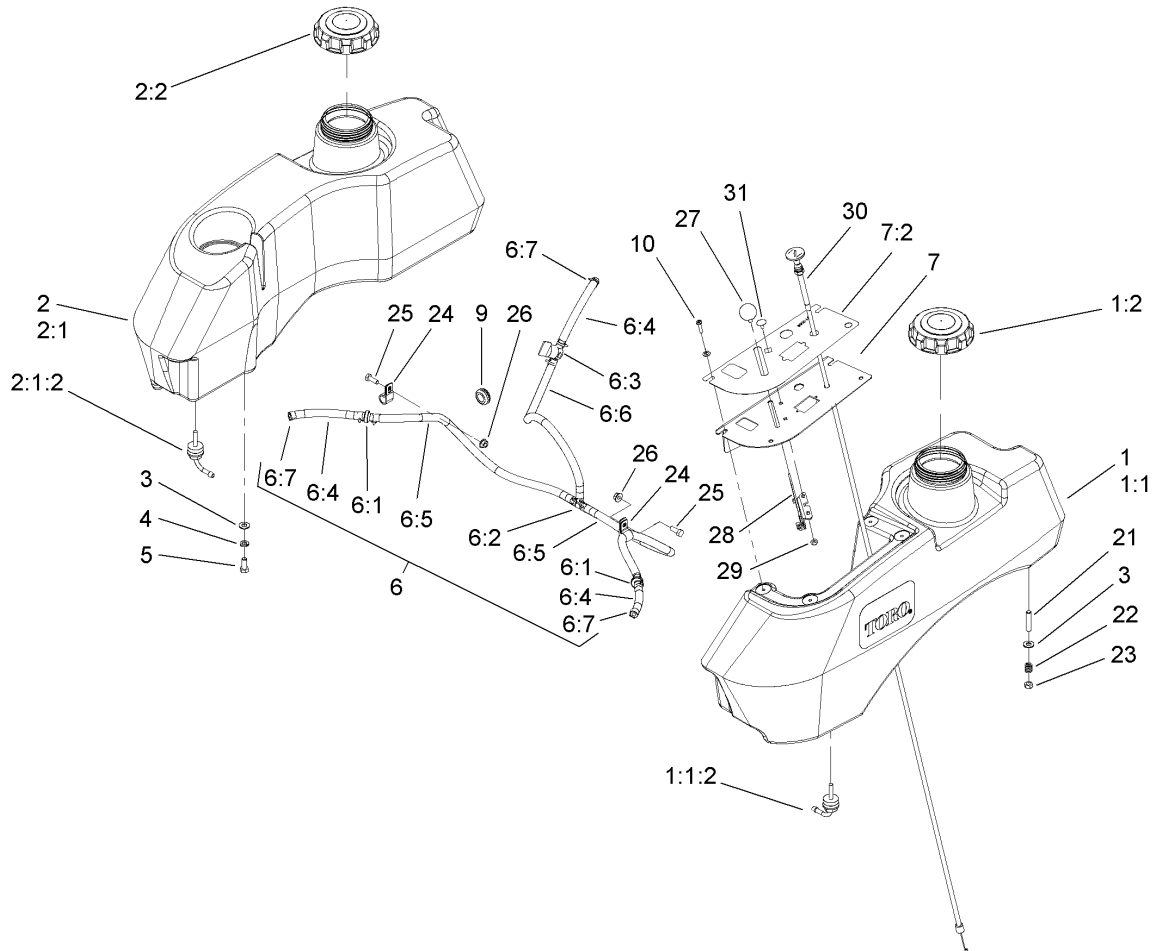

Fuel System Assembly

Ref	Part No.	Qty.	Description	Ref	Part No.	Qty.	Description
1	110-4165	1	LH Fuel Tank Service Kit	10	109-2661	4	Screw-PPH
2	105-3639	1	RH Fuel Tank Service Kit	21	1-633023	4	Stud
2:1:1	103-2605	1	LH Fuel Tank ASM	22	1-633349	4	Spring-Tank, Fuel
1:1:2	103-2605	1	Fitting-Fuel, Bulkhead	23	3296-47	4	Nut-Lock, NI
1:2	109-0346	1	Cap-Fuel, Gas	24	1-513762	2	Clip-Loom
2	105-3639	1	RH Fuel Tank Service Kit	25	321-4	2	Screw-HH
2:1	103-2605	1	RH Fuel Tank ASM	26	32128-33	2	Nut-HF
2:1:2	103-2605	1	Fitting-Fuel, Bulkhead	27	1-513592	1	Knob-Ball
2:2	109-0346	1	Cap-Fuel, Gas	28	1-633696	1	Throttle Cable ASM
2:2	103-2605	1	Fitting-Fuel, Bulkhead	29	3296-2	2	Nut-Lock
3	3256-23	8	Washer-Flat	30	106-9962	1	Control-Choke, Push / Pull
4	1-805005	4	Washer-Lock	31	1-807513	2	Bolt-CARR
5	322-3	4	Screw-HH				
6	1-303077	1	Fuel Line ASM				
6:1	99-5000	2	Valve-Check, Fuel				
6:2	99-5005	1	Fitting-Tee, Barbed				
6:3	1-603770	1	Valve-Fuel				
6:4	109-0678	3	Hose-Fuel				
6:5	110-5701	2	Hose-Fuel				
6:6	109-0297	1	Hose-Fuel				
6:7	1-303077	12	Clamp				
7	107-2149	1	Control Panel ASM				
7:2	110-0439	1	Decal-Panel, Control				
9	1-543296	2	Grommet				

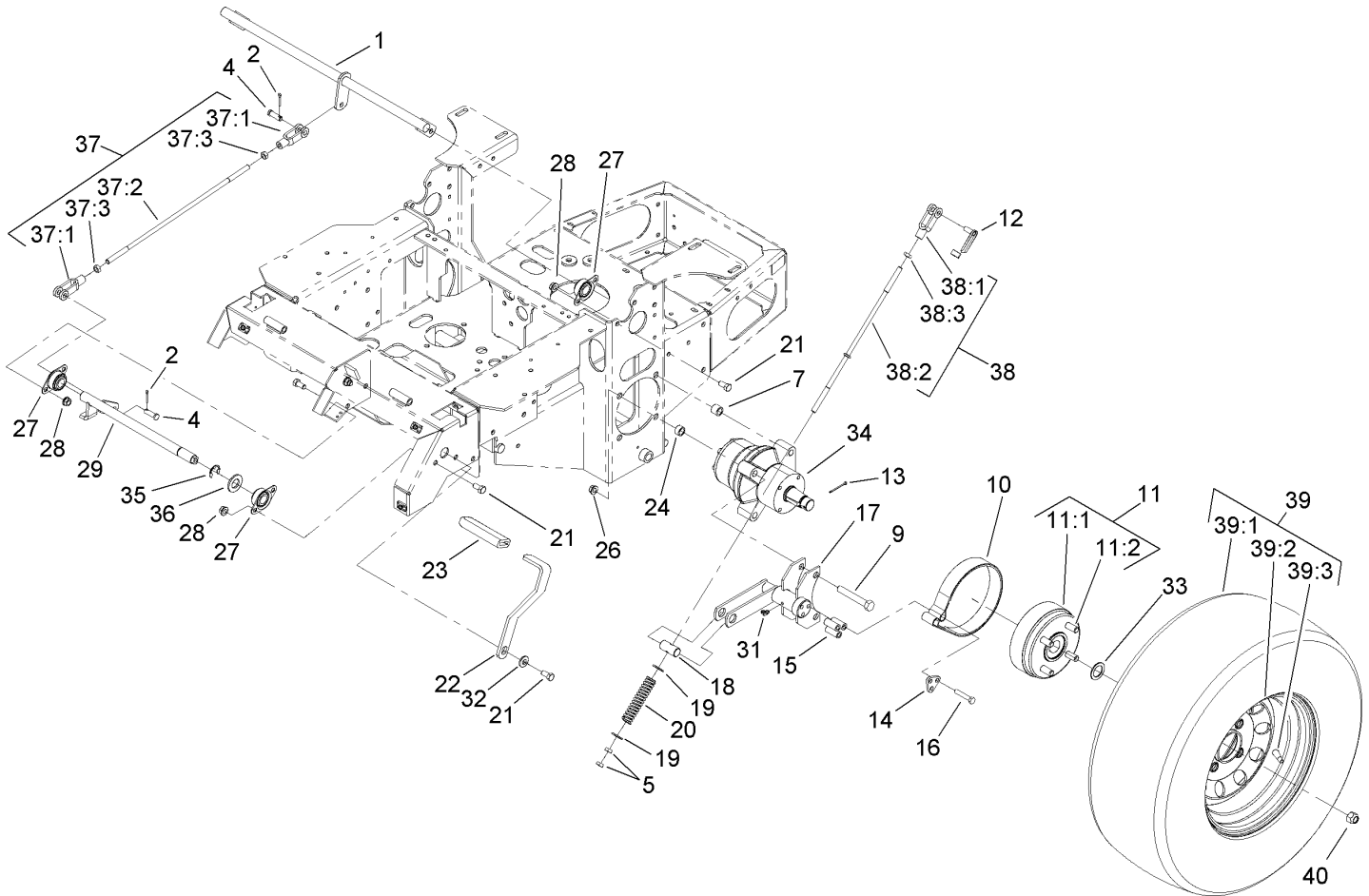

Parking Brake Assembly

Ref	Part No.	Qty.	Description
1	1-652073-03	1	Crank-Brake, Park
2	3272-10	2	Pin-Cotter
4	1-808285	2	Pin-Clevis
5	3219-3	4	Nut-Hex
7	1-653068	4	Spacer-Wheel
9	325-13	8	Screw-HH
10	103-0355	2	Band-Brake
11	103-0590	2	Hub And Wheel ASM
11:1	103-0589	1	Wheel Hub ASM
11:2	1-633926	4	Stud-Wheel
12	103-2399	2	Pin-Spring, Clevis
13	1-806800	2	Pin-Cotter
14	103-0374	2	Retainer-Band, Brake
15	103-0384	6	Spacer
16	322-9	6	Screw-HH
17	103-0352-03	2	Bracket-Brake
18	1-633144	2	Pin-Trunion
19	3256-4	4	Washer-Flat
20	1-633454	2	Spring-Brake
21	323-4	9	Screw-HH
22	1-653074-03	1	Handle-Brake, Park
23	1-633268	1	Grip-Lever, Brake
24	1-653069	4	Spacer-Wheel
26	32128-49	8	Nut-HHF

Ref	Part No.	Qty.	Description
27	1-633102	4	Bearing-Flange, Side
28	3290-357	8	Nut-HHF, Whiz
29	103-3116	1	Shaft-Brake, Parking
31	1481	2	Fitting-Grease
32	98-5975	1	Washer-Belleville
33	1-523157	2	Washer-Spacer
34	103-5333	2	Motor-Wheel
●34:1	109-5965	1	Wheel Motor Seal Kit
●34:2	109-5966	1	Wheel Motor Seal Kit
35	32151-48	1	E-Ring
36	3256-28	1	Washer-Flat
37	103-4328	1	Brake Rod ASM
37:1	1-633131	2	Yoke-Linkage, Brake
37:2	1-653061	1	Linkage-Handle, Brake
37:3	3219-3	2	Nut-Hex
38	103-4329	2	Brake Rod ASM
38:1	1-633131	1	Yoke-Linkage, Brake
38:2	103-0356	1	Rod-Brake
38:3	3219-3	1	Nut-Hex
39	1-653159	2	Wheel And Tire ASM
39:1	1-653160	1	Tire
39:2	1-653161	1	Wheel
39:3	232-27	1	Stem-Valve
40	242-50	8	Nut-Lug

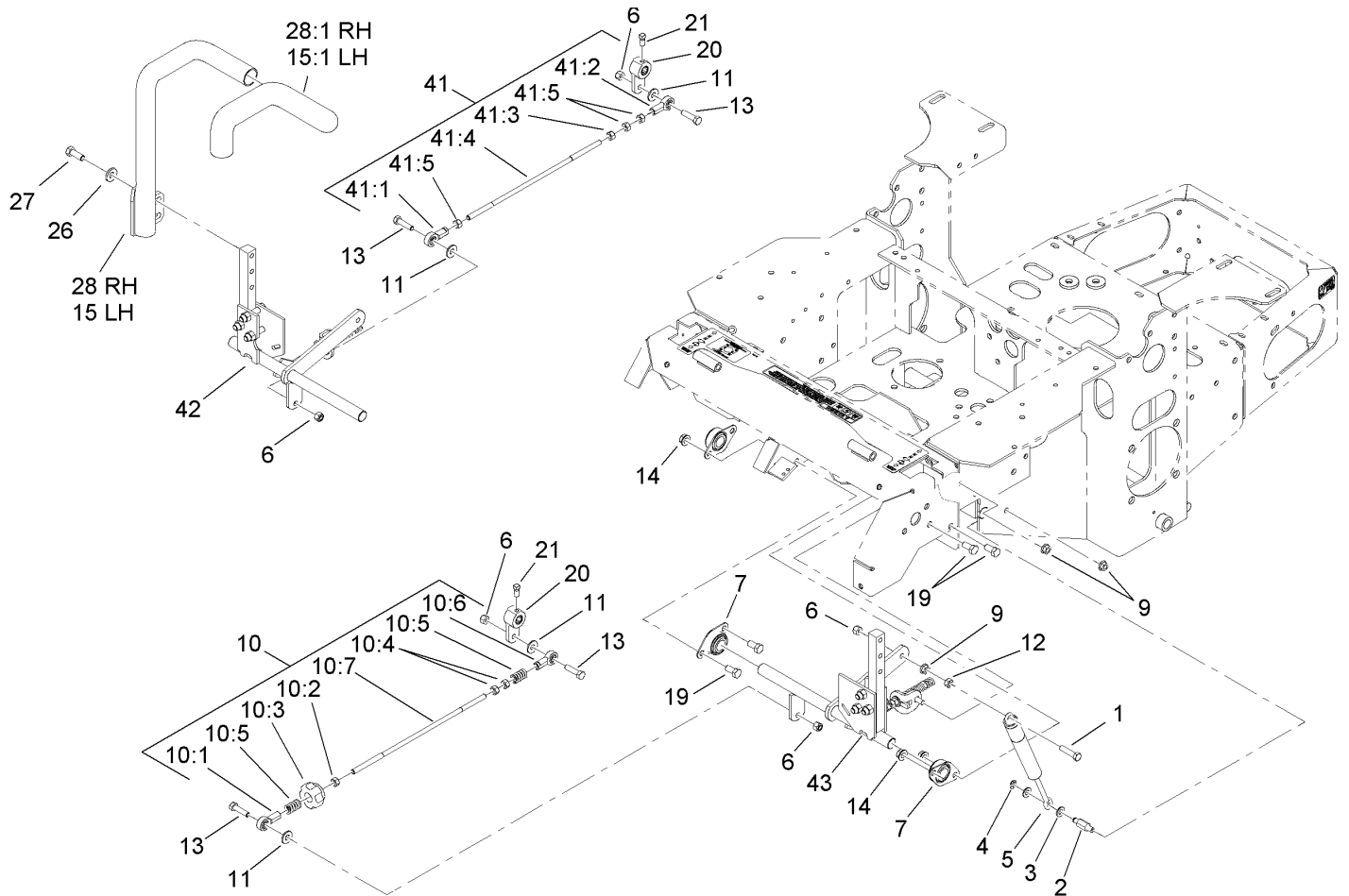

Motion Control Assembly

Ref	Part No.	Qty.	Description
1	1-403180	2	Screw-HH
2	103-4101	2	Pin-Damper
3	3256-23	4	Washer-Flat
4	32120-35	2	Ring-Retaining, EXT
5	109-2339	2	Damper-Control, Motion
6	3296-29	6	Nut-Lock, NI
7	1-633102	4	Bearing-Flange, Side
9	32128-20	10	Nut-HF
10	103-4326	1	Tracking Rod ASM
10:1	1-543017	1	Balljoint-RH
10:2	3219-2	1	Nut-Hex
10:3	103-3060	1	Knob-Tracking
10:4	1-804524	2	Nut
10:5	1-323245	2	Spring-Compression
10:6	1-633152	1	Balljoint-LH
10:7	103-3066	1	Link-Rod, Tracking
11	3256-3	4	Washer-Flat
12	3217-6	2	Nut-Hex
13	322-6	4	Screw-HH
14	3290-357	6	Nut-HHF, Whiz
15	108-7238	1	LH Lever ASM
15:1	106-9987	1	Grip-Control, Motion
19	323-4	6	Screw-HH
20	103-3717	2	Arm-Control

Ref	Part No.	Qty.	Description
21	1-803022	2	Screw-Set
26	98-5975	4	Washer-Belleville
27	323-6	4	Screw-HH
28	108-7237	1	RH Lever ASM
28:1	106-9987	1	Grip-Control, Motion
41	103-4327	1	Tracking ASM
41:1	1-543017	1	Balljoint-RH
41:2	1-633152	1	Balljoint-LH
41:3	1-804524	1	Nut
41:4	103-3066	1	Link-Rod, Tracking
41:5	3219-2	3	Nut-Hex
42	109-3911	1	RH Motion Control ASM
43	109-3912	1	LH Motion Control ASM

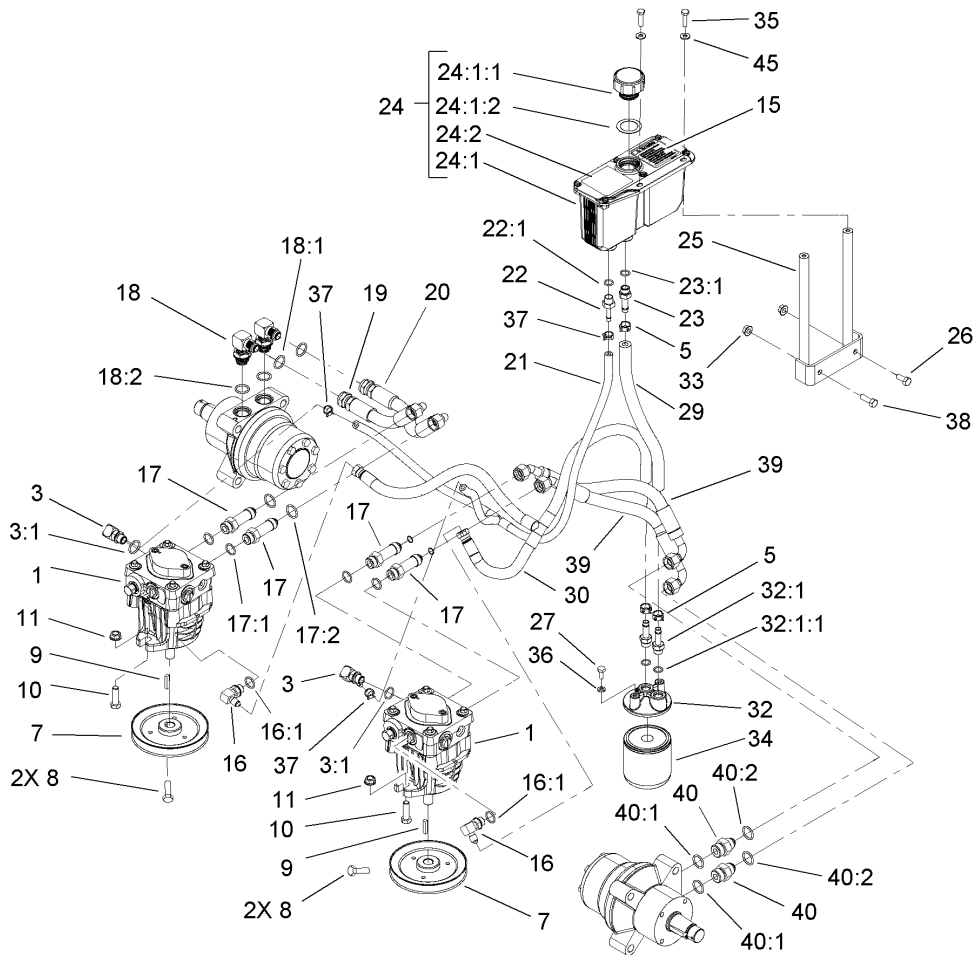

Hydraulic System Assembly

Ref	Part No.	Qty.	Description
1	103-1942	2	Pump-HYD
3	103-1799	2	Elbow-90 DEG
3:1	237-42	1	O-Ring
5	103-1988	3	Clamp-Hose
7	1-653156	2	Pulley
8	1-803050	4	Screw-Set
9	1-807272	2	Key
10	323-7	4	Screw-HH
11	3290-357	4	Nut-HHF, Whiz
15	103-2644	1	Decal-Exhaust
16	103-1802	2	Fitting-HYD, 90 DEG
16:1	1-603921	1	O-Ring
17	103-1940	4	Adapter-HYD, Straight
17:1	237-79	1	O-Ring
17:2	1-603992	1	O-Ring
18	1-633605	2	Fitting-HYD, 90 DEG
18:1	1-603992	1	O-Ring
18:2	237-80	1	O-Ring
19	1-653186	1	Hose-Front
20	1-653187	1	Hose-Rear, RH
21	103-2357	1	HYD Hose ASM
22	103-1801	1	Adapter-Straight
22:1	237-42	1	O-Ring
23	103-1912	1	Adapter-Straight

Ref	Part No.	Qty.	Description
23:1	237-42	1	O-Ring
24	103-1947	1	HYD Reservoir ASM
24:1		1	Reservoir-HYD
24:1:1	103-1948	1	Cap-Reservoir, HYD
24:1:2	103-1949	1	Gasket-Cap
24:2	1-523552	1	Decal-Tank, HYD
25	103-3071-03	1	Stand-Reservoir
26	322-3	1	Screw-HH
27	321-3	2	Screw-HH
29	103-3077	1	HYD Hose ASM
30	103-2930	1	HYD Hose ASM
32	103-2889	1	Filter Head ASM
32:1	103-1912	2	Adapter-Straight
32:1:1	237-42	1	O-Ring
33	32128-20	2	Nut-HF
34	1-633750	1	Filter-Oil, HYD
34	1-633752	1	Filter-HYD, Winter
35	321-6	2	Screw-HH
36	1-805004	2	Washer-Lock
37	103-1716	3	Clamp-Hose
38	322-5	1	Screw-HH
39	103-3809	2	Hose-LH
40	1-603991	2	Fitting-Straight
40:1	237-80	1	O-Ring

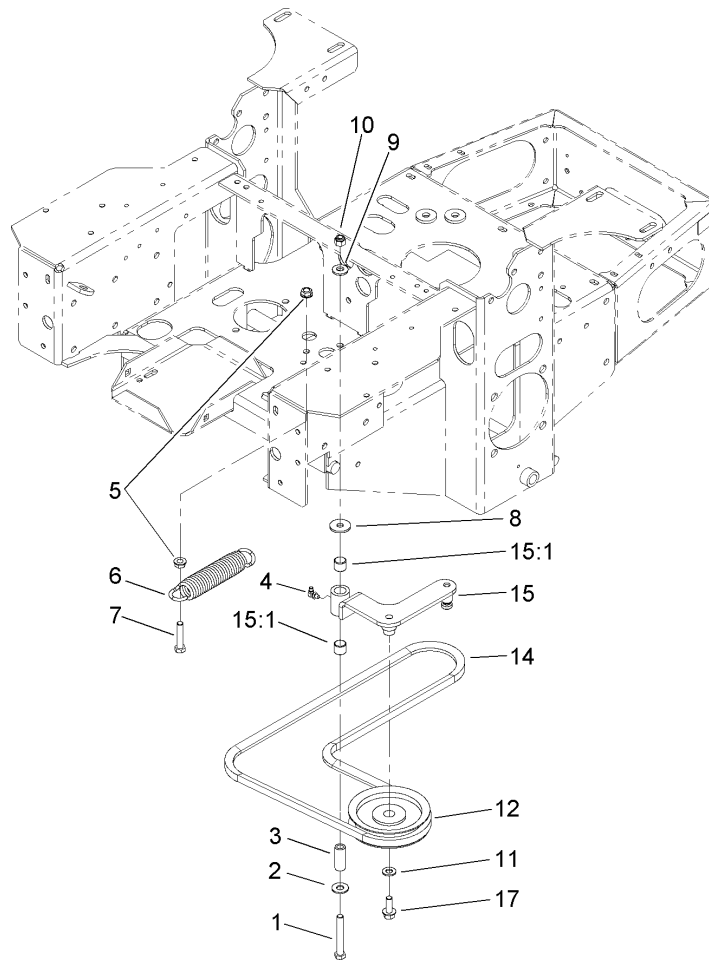

Pump Idler and Belt Assembly

Ref	Part No.	Qty.	Description
1	323-13	1	Screw-HH
2	3256-4	1	Washer-Flat
3	1-603044	1	Bushing
4	302-40	1	Fitting-Grease
5	3290-357	2	Nut-HHF, Whiz
6	103-4480	1	Spring-Extension
7	323-9	1	Screw-HH
8	63-8410	1	Washer
9	98-5975	1	Washer-Belleville
10	3296-39	1	Nut-Lock, NI
11	3256-24	1	Washer-Flat
12	1-603843	1	Pulley-Idler
14	107-3960	1	Belt
15	103-4482	1	Idler Arm ASM
15:1	103-4681	2	Sleeve-Bearing
17	3234-11	1	Screw-HHF

--	--	--	--

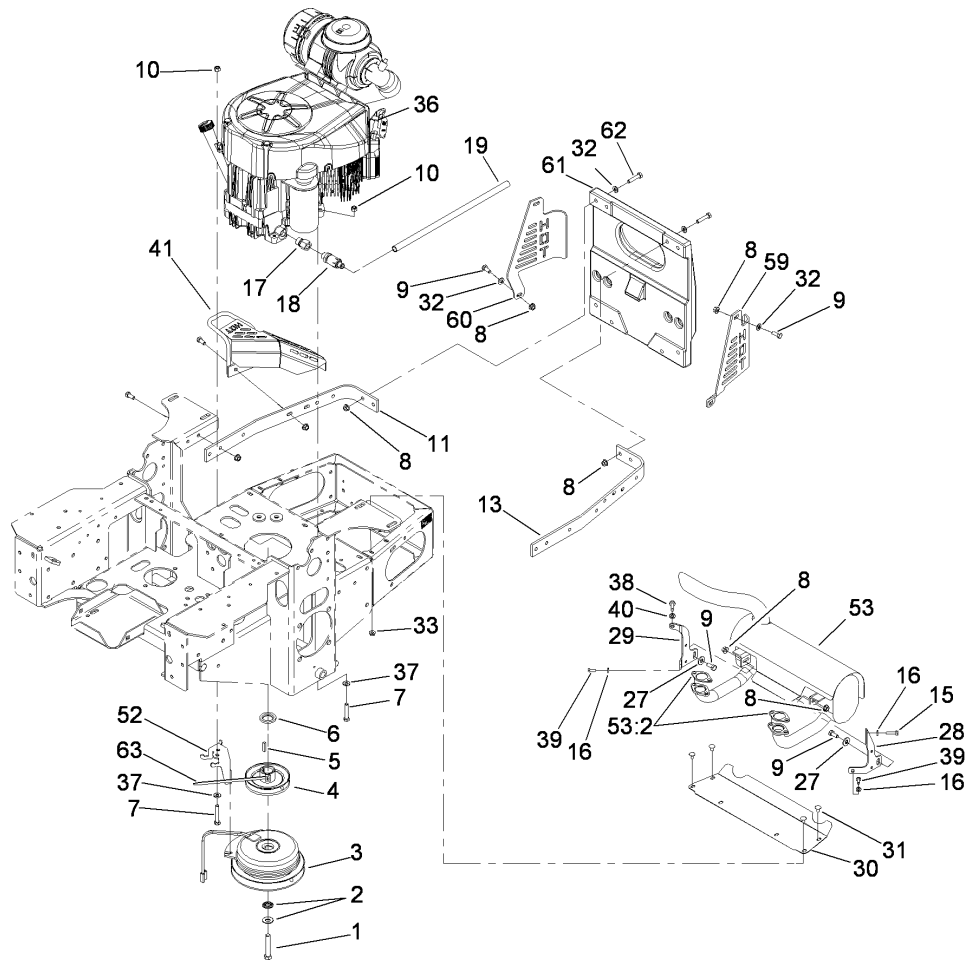

Engine, Clutch and Muffler Assembly

Ref	Part No.	Qty.	Description
1	3212-12	1	Screw-HH
2	1-603610	2	Washer-Spring
3	109-2916	1	Clutch
4	103-3913	1	Pulley
5	1-807259	1	Key
6	103-2308	1	Spacer-Crankshaft
7	322-10	4	Screw-HH
8	32128-20	29	Nut-HF
9	322-3	15	Screw-HH
10	3296-29	4	Nut-Lock, NI
11	103-3078-03	1	Strap-Guard, RH
13	103-3164-03	1	Strap-Guard, LH
15	33113-025	1	Screw-HH
16	1-805004	3	Washer-Lock
17	103-1966	1	Adapter
18	92-6877	1	Valve-Drain, Oil
19	106-7022	1	Tube-Drain, Oil
27	3256-3	3	Washer-Flat
28	103-2993-03	1	Bracket-Muffler, LH
29	103-2994-03	1	Bracket-Muffler, RH
30	103-2740-03	1	Deflector-Short
31	3229-10	4	Screw-CARR
32	3256-23	12	Washer-Flat
33	32128-33	4	Nut-HF

Ref	Part No.	Qty.	Description
36		1	Engine-Kawasaki, FH680V-Ds21
37	1-303334	4	Washer-Spring
38	33114-025	1	Screw-HH
39	33113-016	2	Screw-HH
40	1-805005	1	Washer-Lock
41	103-3218-03	1	Guard-Tailpipe
52	109-7070-03	1	Anchor-Clutch
53	103-3427	1	Muffler Kit
53:2	1-653313	2	Gasket-Exhaust
59	103-3287-03	1	Guard-Muffler, LH
60	103-3288-03	1	Guard-Muffler, RH
61	107-8421-03	1	Weight-Notched, 60 Lb
62	322-7	8	Screw-HH
63	1-303335	1	Tie-Plastic

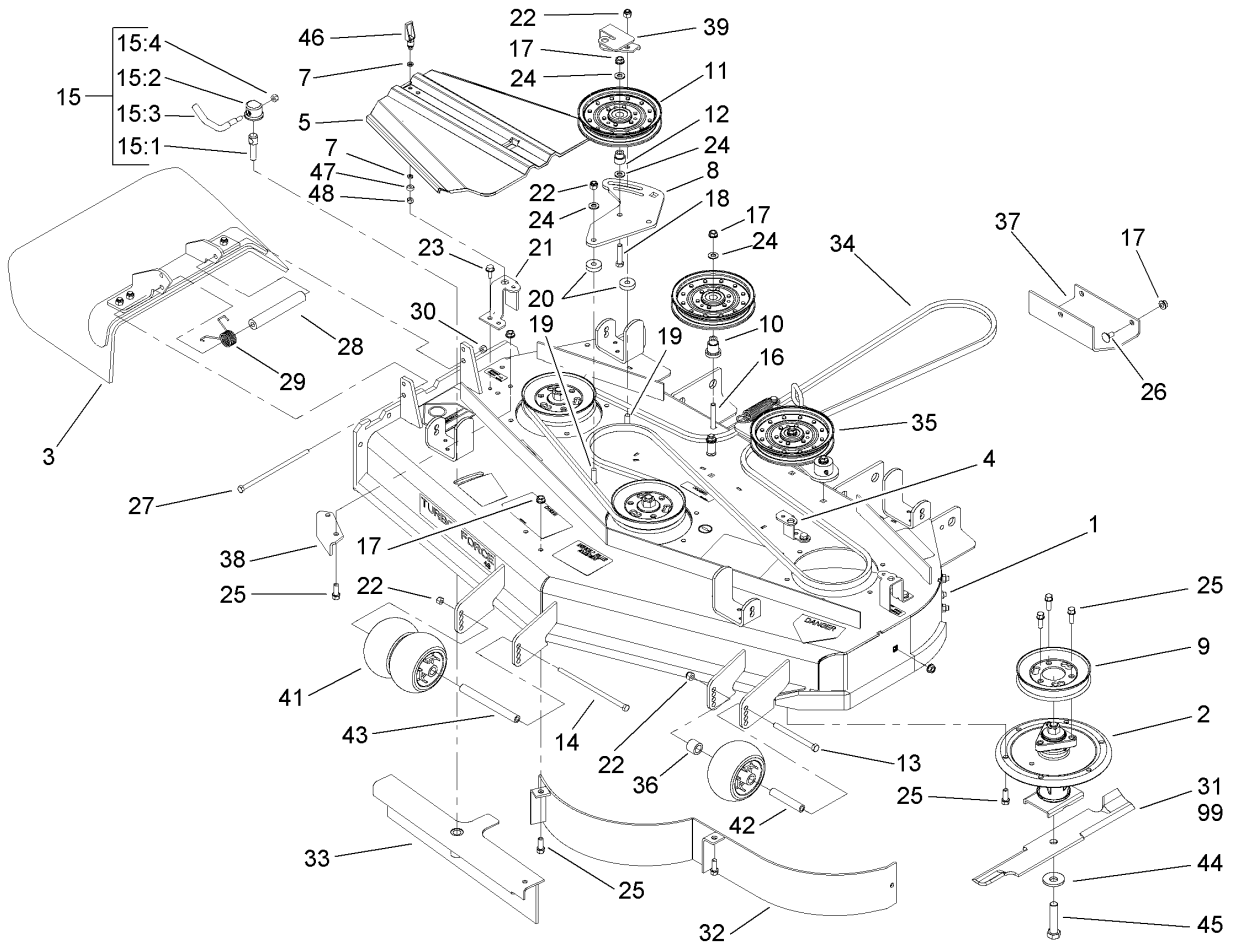

Deck Assembly

Ref	Part No.	Qty.	Description
1	107-8515	1	Deck Decal ASM
2	107-8504	3	Spindle ASM
3	108-2792	1	Rubber Deflector ASM
4	108-2177-01	1	Bracket-Cover, Tall
5	107-8536	2	Cover-Belt
7	99-3058	2	Washer
8	107-8516-01	1	Plate-Idler
9	107-1684	3	Pulley
10	106-3214	1	Mount-Pulley
11	1-633109	2	Idler-Flat
12	1-603496	1	Bushing-Idler
13	323-23	1	Screw-HH
14	323-28	1	Screw-HH
15	107-1664	1	Lever ASM
15:1	106-3239	1	Screw-Lock
15:2	107-1644	1	Cap-Lock
15:3	106-3241	1	Lever-Lock
15:4	3296-29	1	Nut-Lock, NI
16	3231-31	1	Screw-CARR
17	3290-357	32	Nut-HHF, Whiz
18	323-9	1	Screw-HH
19	3231-4	2	Screw-CARR
20	105-7788	2	Spacer
21	108-4121-01	2	Bracket-Cover

Ref	Part No.	Qty.	Description
22	3296-39	4	Nut-Lock, NI
23	32144-70	3	Screw-HWHTF
24	3256-24	4	Washer-Flat
25	92-1624	32	Screw
26	3231-1	7	Screw-CARR
27	322-50	1	Screw-HH
28	105-4622	1	Spacer
29	108-4052	1	Spring-Torsion
30	3296-29	1	Nut-Lock, NI
31	107-3192-03	3	Blade-16.5 Inch (High Flow)
32	107-8510-01	1	Baffle ASM
33	107-8506-01	1	Baffle ASM
34	114-8154	1	Belt-V
35		1	Spring Idler ASM
36	98-7913	1	Tube-Spacer
37	107-3166-01	1	Skid
38	107-8541-01	1	Baffle-Discharge
39	108-2228-01	1	Bracket-Cover
41	1-603299	3	Roller-Scalp, Anti
42	98-7912	1	Tube-Spacer
43	98-5967	1	Spacer-Wheel
44	103-0865	3	Washer-Blade Bolt, Heavy
45	103-0862	3	Screw-Cap
46	106-6777	2	Handle-Latch, Swell

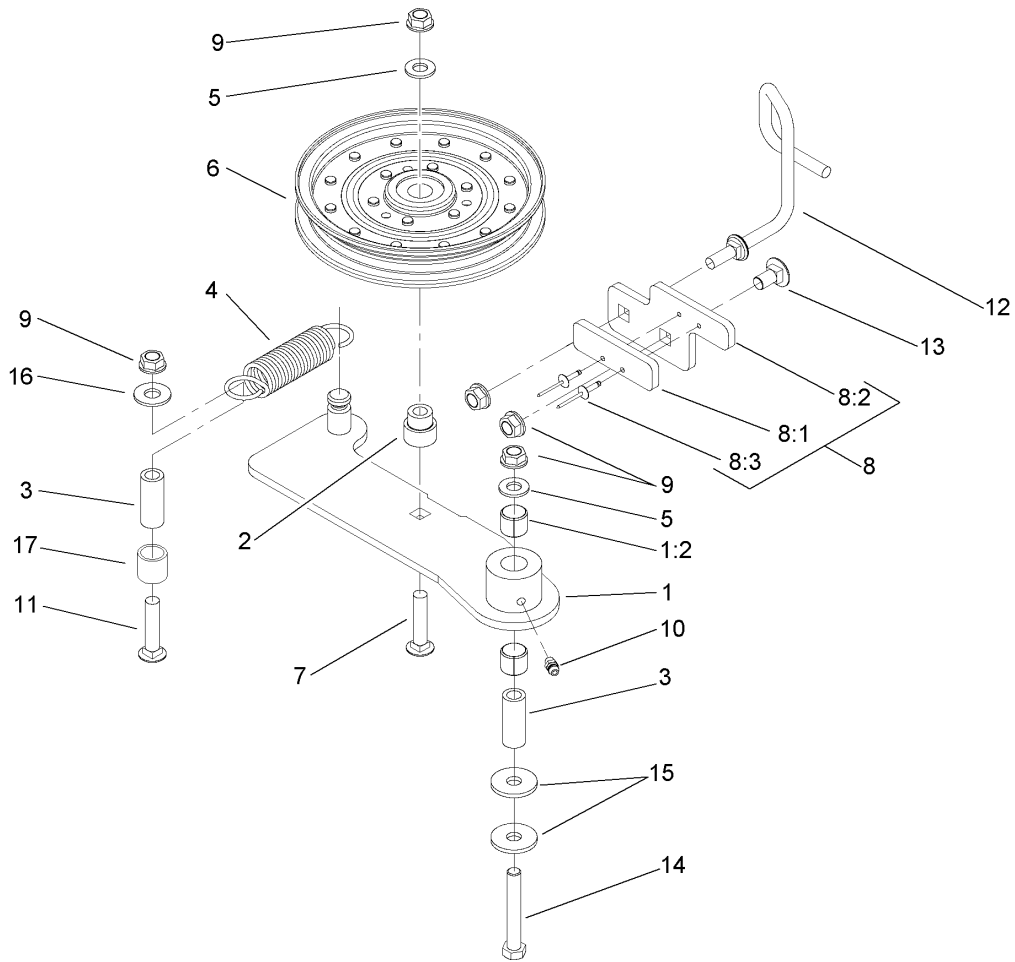

Idler Assembly

Ref	Part No.	Qty.	Description
1	108-4062	1	Idler Arm ASM
1:2	103-4681	2	Sleeve-Bearing
2	1-603496	1	Bushing-Idler
3	1-603044	2	Bushing
4	108-4056	1	Spring-Extension
5	3256-24	2	Washer-Flat
6	1-633109	1	Idler-Flat
7	3231-6	1	Screw-CARR
8		1	Stop Pad ASM
8:1	106-3229	1	Pad-Bumper
8:2	107-1697-01	1	Plate-Stop
8:3	3269-24	2	Rivet
9	3290-357	5	Nut-HHF, Whiz
10	302-5	1	Fitting-Grease
11	3231-31	1	Screw-CARR
12	108-4072	1	Guide-Belt
13	3231-1	1	Screw-CARR
14	323-12	1	Screw-HH
15	2844	2	Washer
16	3256-4	1	Washer-Flat
17	108-4063	1	Spacer-Rubber

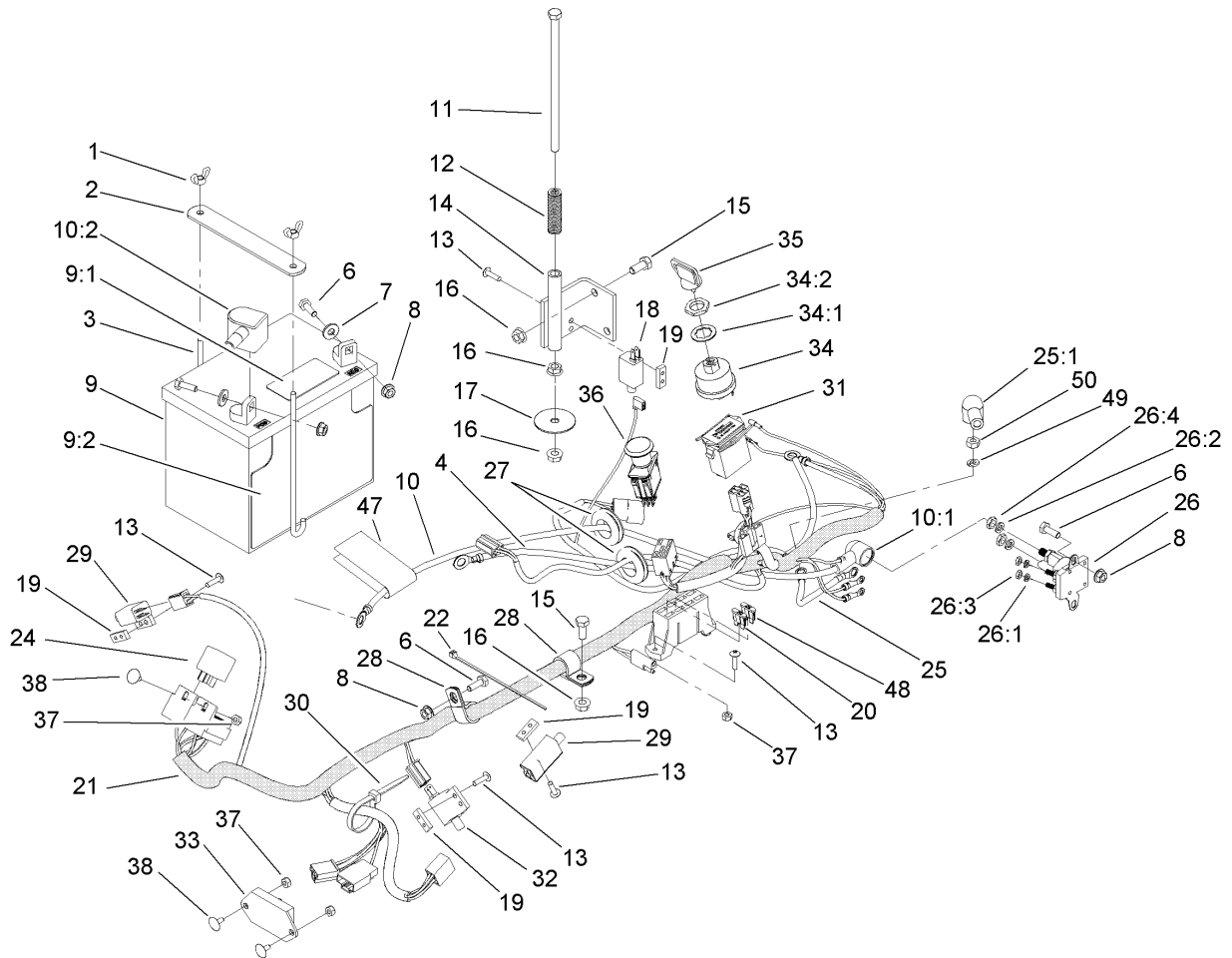

Electrical System Assembly

Ref	Part No.	Qty.	Description
1	1-543792	2	Wingnut
2	107-9277-03	1	Strap-Holddown, Battery
3	1-633651	2	Bolt-Holddown
4	103-0705	1	Cable-Ground, Negative
6	321-4	5	Screw-HH
7	3256-2	2	Washer-Flat
8	32128-33	5	Nut-HF
9	105-1692	1	Battery
9:1	104-4163	1	Decal-Battery
9:2	104-4164	1	Decal-Battery
10	109-7621	1	Positive Battery Cable ASM
10:1	1-543393	1	Insulator-Solenoid
10:2	109-2407	1	Insulator-Battery
11	1-800282	1	Screw-HH
12	1-523415	1	Spring-Switch, Seat
13	1-803075	10	Screw-Head, Truss
14	1-652072-03	1	Bracket-Switch, Seat
15	322-3	3	Screw-HH
16	32128-20	5	Nut-HF
17	1-653036	1	Washer
18	1-513152	1	Switch-Closed, Normally
19	1-633181	4	Plate-Tapped
20	109103	1	Fuse-30 Amp
21	110-0318	1	Harness-Electrical

Ref	Part No.	Qty.	Description
22	1-303287	3	Tie-Plastic
24	1-643275	2	Relay
25	109-7620	1	Positive Starter Cable ASM
25:1	1-543393	2	Insulator-Solenoid
26	1-513075	1	Switch-Solenoid
26:1	3253-17	2	Washer-Lock
26:2	3253-4	2	Washer-Lock
26:3	3219-14	2	Nut-Hex
26:4	3220-2	2	Nut-Jam
27	1-543286	2	Grommet
28	1-633396	2	Clip-Loom
29	1-513051	2	Switch-Open, Normally
30	1-303335	4	Tie-Plastic
31	1-513374	1	Meter-Hour
32	1-633111	1	Switch
33	100-6186	1	Module-Delay, Seat
34	104-2541	1	Switch ASM
34:1	218-461	1	Nut-HH
34:2	3254-5	1	Washer-Tooth
35	63-8360	2	Key-Ignition
36	103-5221	1	Switch-PTO
37	3296-2	6	Nut-Lock
38	1-807513	4	Bolt-CARR
47	107-9309	1	Decal-Instructions, Charging

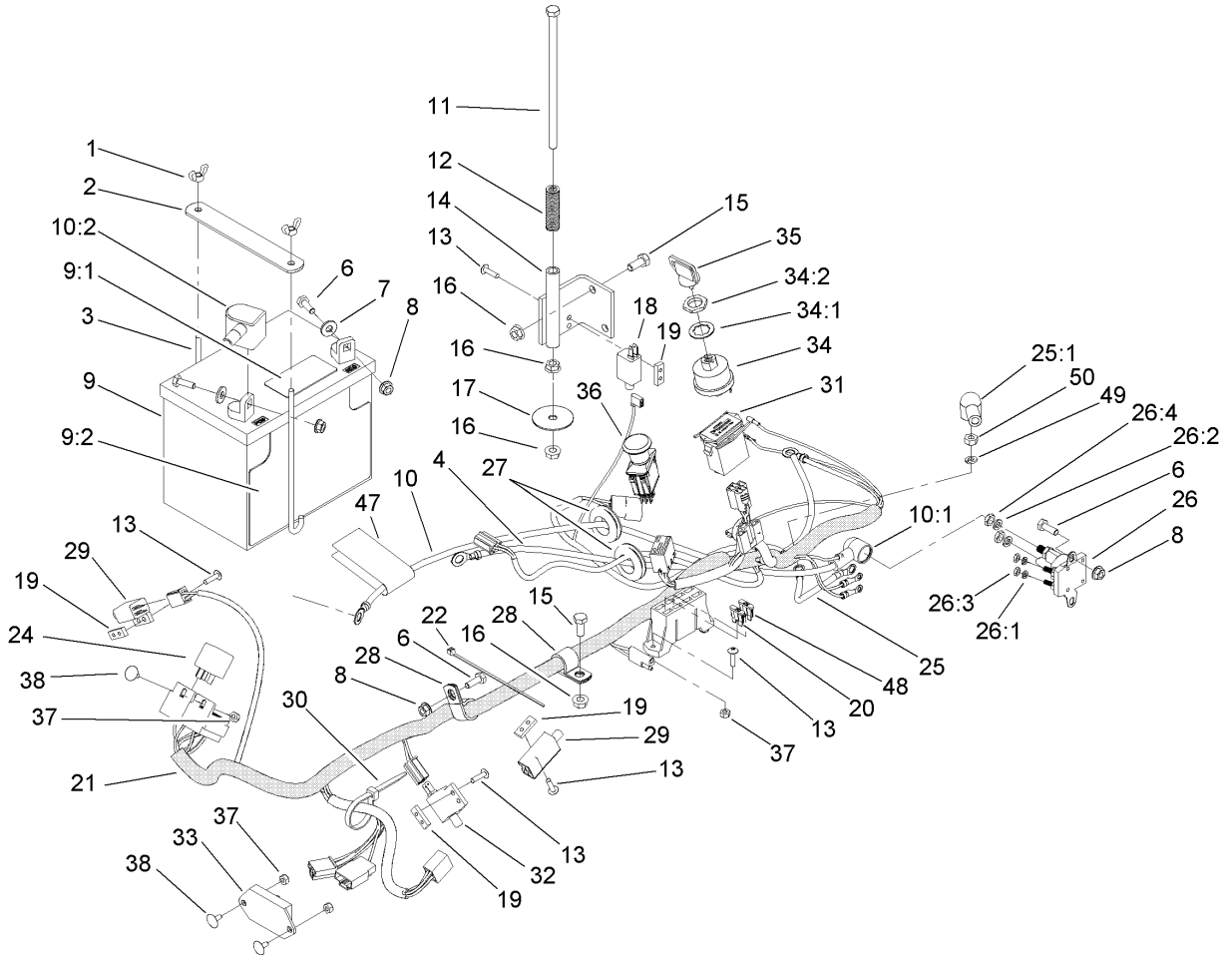

Electrical System Assembly (continued)

Ref	Part No.	Qty.	Description
48	109102	1	Fuse-25 Amp
49	1-805004	1	Washer-Lock
50	3217-5	1	Nut-Hex

--	--	--	--

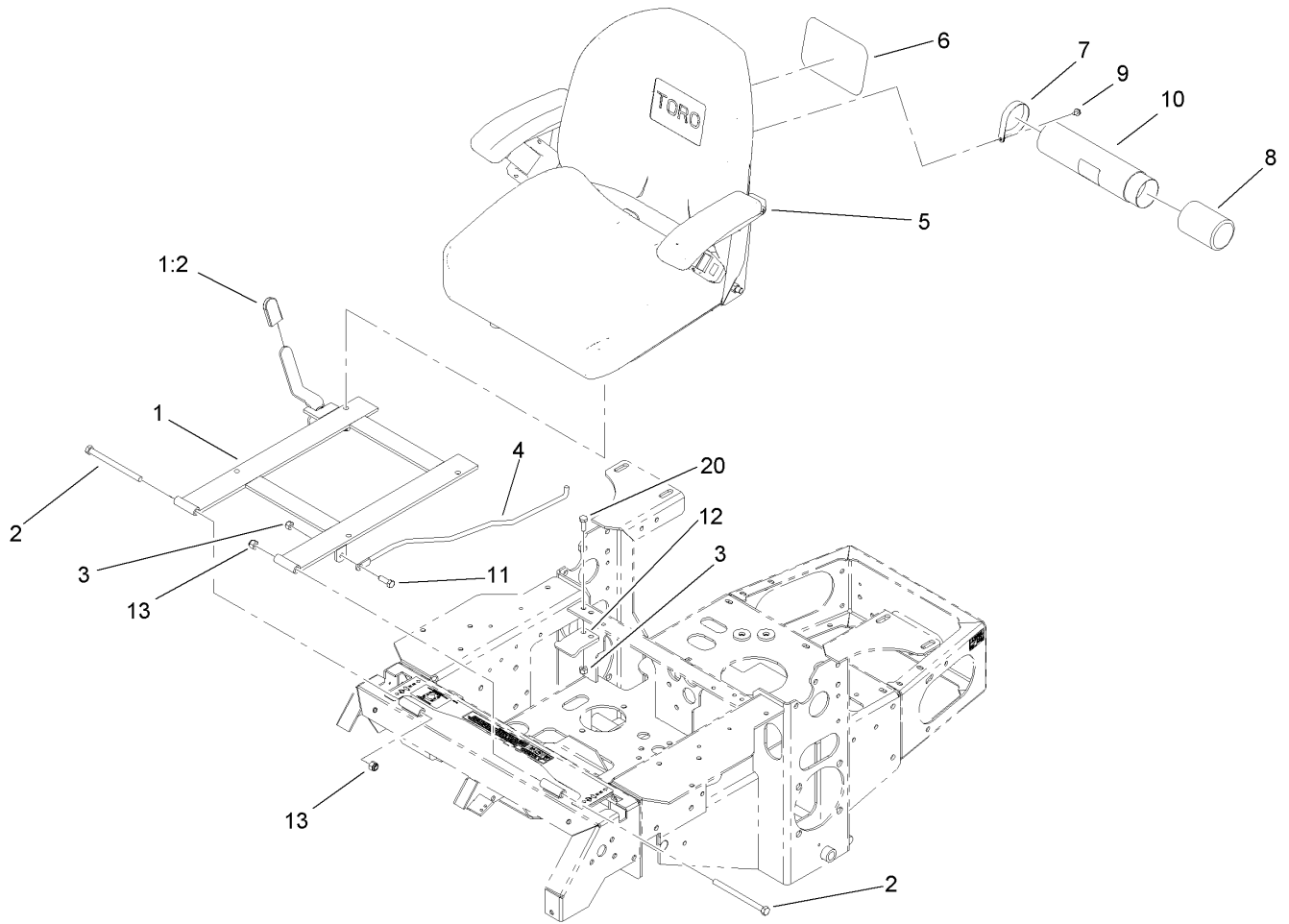

Seat and Bracket Assembly

Ref	Part No.	Qty.	Description				
1	110-5850	1	Seat Frame And Latch ASM				
1:2	103-4434	1	Grip-Lever				
2	323-39	2	Screw-HH				
3	3296-29	3	Nut-Lock, NI				
4	103-1731	1	Rod-Retainer, Seat				
5	110-0446	1	Seat ASM				
6	99-4693	1	Decal				
7	2412-120	2	R-Clamp				
8	104-7048	1	Cap-Housing				
9	32104-76	2	Screw				
10	104-7050	1	Housing-Manual				
11	322-5	1	Screw-HH				
12	103-5961	1	Catch-Latch, Seat				
13	3296-39	2	Nut-Lock, NI				
20	322-4	2	Screw-HH				

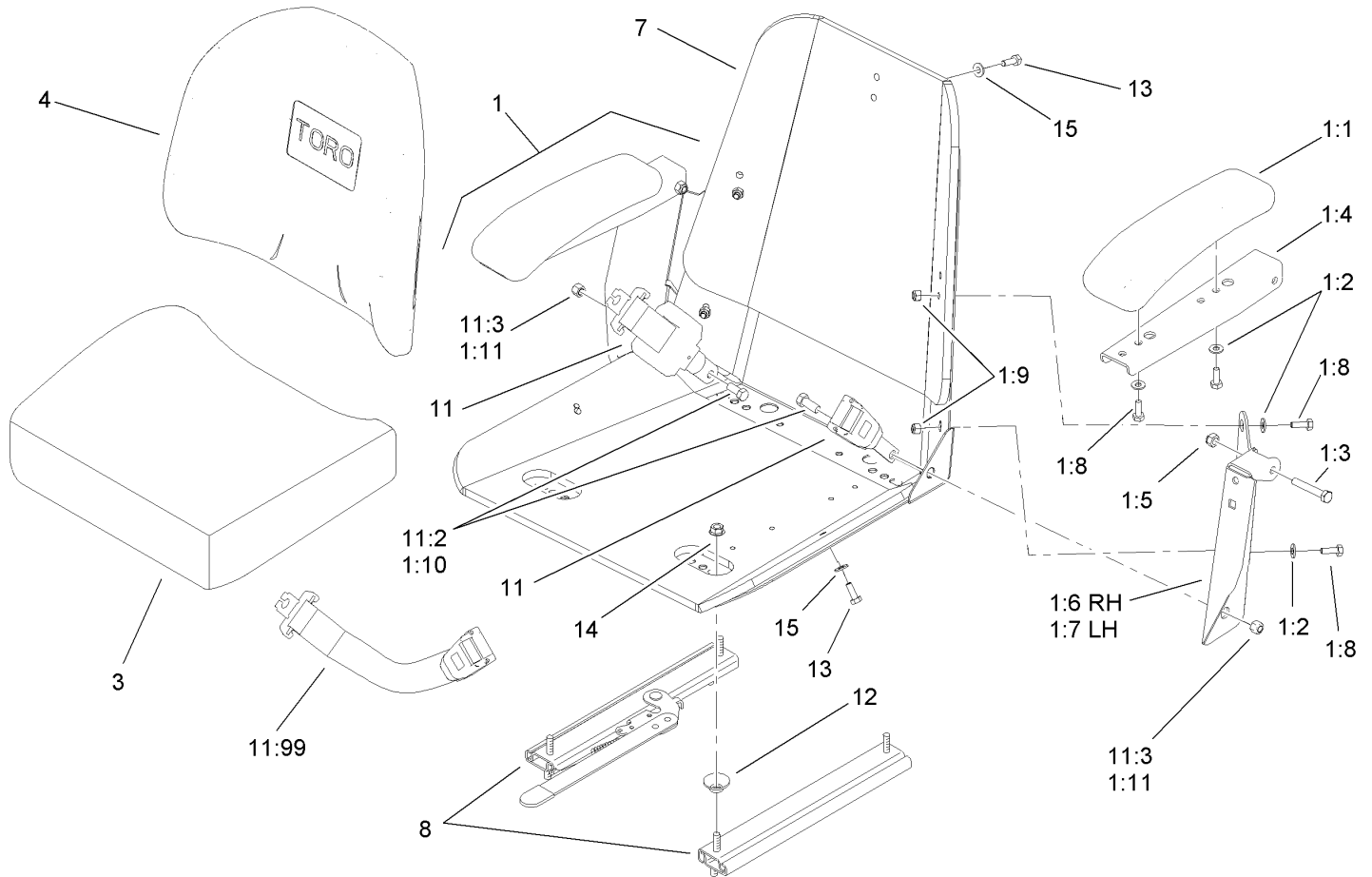

Seat and Bracket Assembly No. 110-0446

Ref	Part No.	Qty.	Description
1	110-5719	1	Armrest Kit
1:1	110-4163	2	Cushion-Rest, Arm
1:2	3256-22	4	Washer-Flat
1:3	322-10	2	Screw-HH
1:4	105-3623	2	Channel-Armrest
1:5	32153-3	2	Nut-Hex, Side Deform
1:6	105-3621	1	Bracket-Armrest, RH
1:7	105-3622	1	Bracket-Armrest, LH
1:8	321-30	8	Screw-HH
1:9	3296-42	4	Nut-Lock, NI
1:10	325-2	2	Screw-HH
1:11	3296-23	2	Nut-Lock, NI
3	110-4162	1	Cushion-Seat, Bottom
4	110-0447	1	Cusion-Seat, Back
7	1-633859	1	Frame-Seat
8	1-643255	1	Track-Seat
11	110-0883	1	Retractable Seatbelt Kit
11:2	3212-4	2	Screw-HH
11:3	3296-7	2	Nut-Lock
11:99	109-6226	1	Seat Belt Extension Kit
12	1-543401	4	Spacer-Track
13	321-30	5	Screw-HH
14	32128-20	4	Nut-HF
15	3256-22	5	Washer-Flat

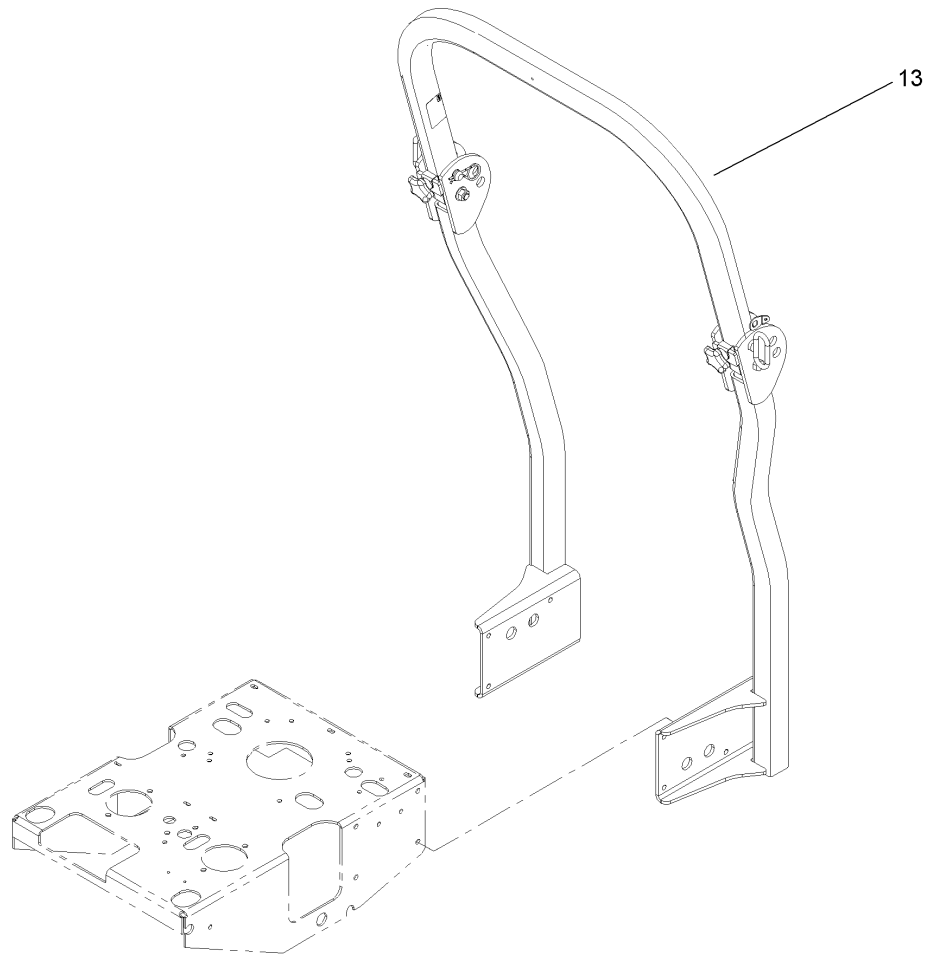

Roll-Over Protection System Assembly

Ref	Part No.	Qty.	Description				
13	107-8093	1	ROPS ASM				

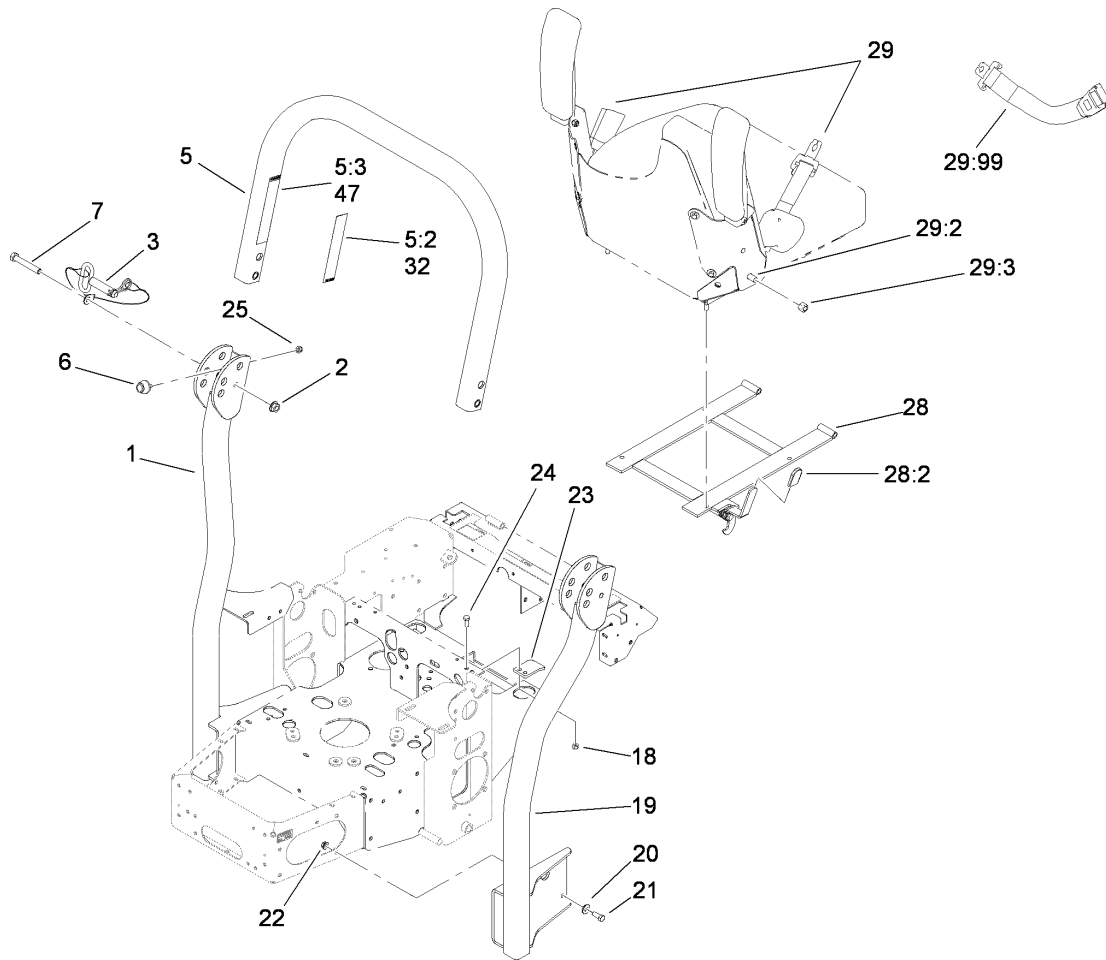

Roll-Over Protection System Assembly No. 107-8093

Ref	Part No.	Qty.	Description
②1		1	LH Tube Support ASM
2	32128-23	2	Nut-HF
3	103-4553	2	ROPS Fold Pin ASM
②5		1	Upper Tube ASM
5:2	107-2100	1	Decal
5:3	107-2102	1	Decal-Warning, Folding ROPS
6	109-2365	2	Bumper-Rubber (W/Stud)
7	325-13	2	Screw-HH
18	3296-29	2	Nut-Lock, NI
②19		1	RH Tube Support ASM
20	98-5975	8	Washer-Belleville
21	323-6	8	Screw-HH
22	3290-357	8	Nut-HHF, Whiz
23	107-3059	1	Catch-Latch, Seat
24	322-4	2	Screw-HH
25	3296-73	2	Nut-Lock, NI
28	110-5850	1	Seat Frame And Latch ASM
28:2	103-4434	1	Grip-Lever
29	110-0883	1	Retractable Seatbelt Kit
29:2	3212-4	2	Screw-HH
29:3	3296-7	2	Nut-Lock
29:99	109-6226	1	Seat Belt Extension Kit
32	107-3069	1	Decal-Warning, Folding ROPS (Ce)

Ref	Part No.	Qty.	Description
47	107-2102	1	Decal-Warning, Folding ROPS

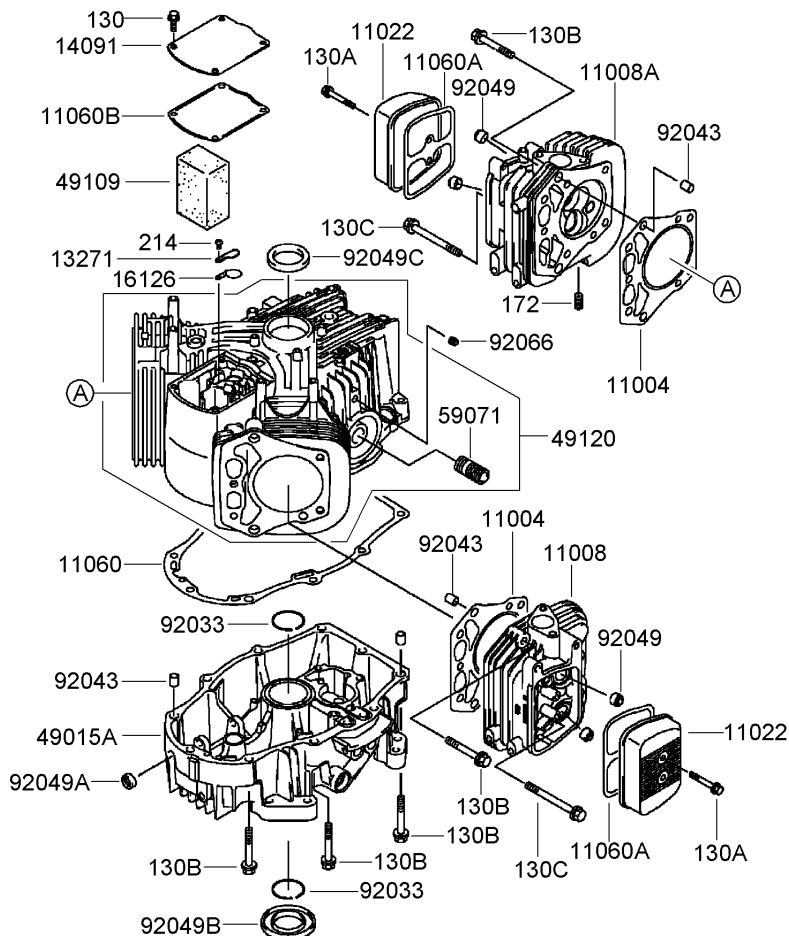

Cylinder and Crankcase Assembly Kawasaki FH680V-DS21

Ref	Part No.	Qty.	Description
④11004	11004-7006	2	Gasket-Head
④11008	11008-7023	1	Head-Cylinder, No.2
④11008A	11008-7024	1	Head-Cylinder, No.1
④11022	11022-7002	2	Case-Rocker
④11060	11060-7012	1	Gasket-Cover, Crankcase
④11060A	11060-7013	2	Gasket-Case, Rocker
④11060B	11060-7014	1	Gasket-Breather
④13271	13271-7006	1	Plate
④14091	14091-7004	1	Cover
④16126	16126-7001	1	Valve
④49015A	49015-7064	1	Cover-Crankcase
④49109	49109-7003	1	Element-Breather
④49120	49120-7037	1	Crankcase
④59071	59071-2079	1	Joint
④92033	92033-7004	2	Ring-Snap
④92043	92043-7001	6	Pin
④92049	92049-7001	4	Seal-Oil, R V C2 (6X11X10.2)
④92049A	92049-7005	1	Seal-Oil, S O (8X14X5 H S)
④92049B	92049-7011	1	Seal-Oil, S D (35X62X8 L H S)
④92049C	92049-7014	1	Seal-Oil, S D (35X52X7 R H S)
④92066	92066-7002	1	Plug
④130	130B0612	4	Bolt-Flanged (6X12)
④130A	130B0640	4	Bolt-Flanged (6X40)
④130B	130T0850	18	Bolt-Flanged (8X50)

Ref	Part No.	Qty.	Description
④130C	130T0875	2	Bolt-Flanged (8X75)
④172	172G0818	4	Bolt-Stud (8X18)
④214	214B0408	1	Screw-Pan (4X8)

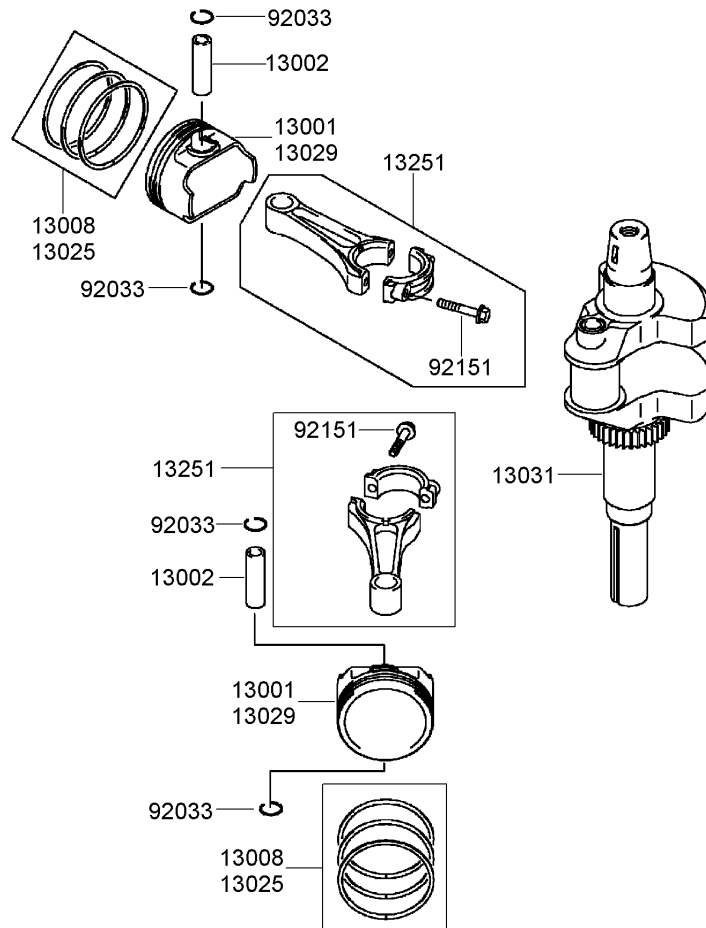

Piston and Crankshaft Assembly Kawasaki FH680V-DS21

Ref	Part No.	Qty.	Description
④13001	13001-7007	2	Piston-Engine
④13002	13002-7001	2	Pin-Piston
④13008	13008-6058	2	Ring Set-Piston
④13025	13025-7002	1	Ring Set-Piston (L,0.50)
④13029	13029-7003	1	Piston-Engine (L,0.50)
④13031	13031-7048	1	Crankshaft
④13251	13251-7005	2	Connecting Rod ASM
④92033	92033-7002	4	Ring-Snap
④92151	92151-7017	4	Bolt (6X35)

--	--	--	--

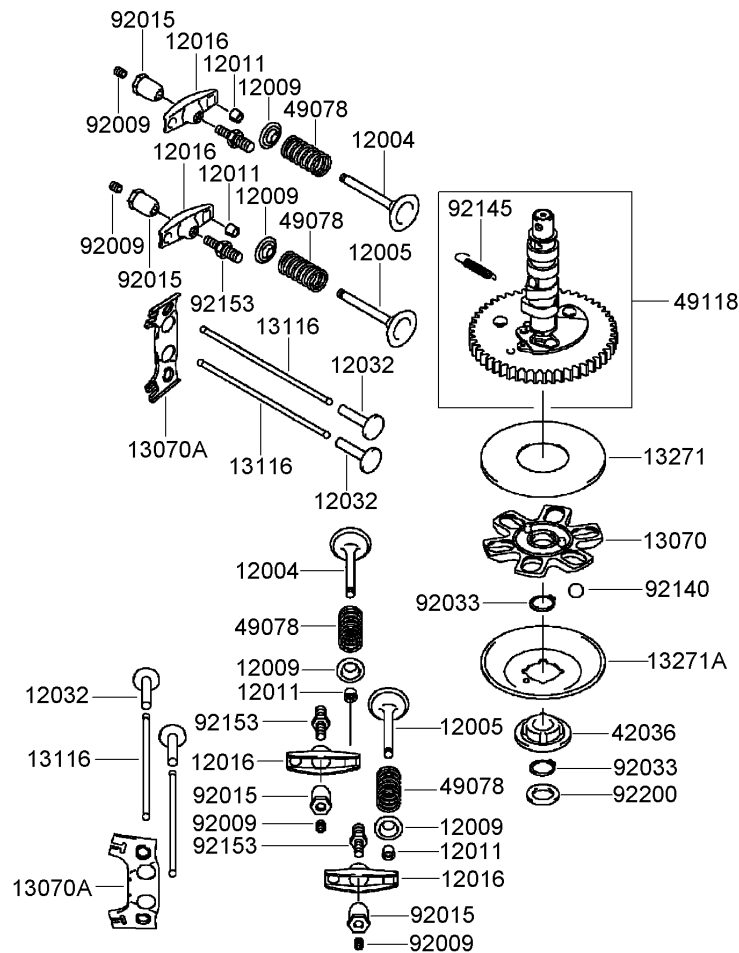

Valve and Camshaft Assembly Kawasaki FH680V-DS21

Ref	Part No.	Qty.	Description
④12004	12004-7002	2	Valve-Intake
④12005	12005-7004	2	Valve-Exhaust
④12009	12009-7001	4	Retainer-Spring, Valve
④12011	12011-2056	8	Collet
④12016	12016-7007	4	Arm-Rocker
④12032	12032-7001	4	Tappet
④13070	13070-7004	1	Guide
④13070A	13070-7007	2	Guide
④13116	13116-7002	4	Rod-Push
④13271	13271-7007	1	Plate
④13271A	13271-7021	1	Plate-Governor
④42036	42036-7010	1	Sleeve
④49078	49078-7002	4	Spring-Valve, Engine (In)
④49118	49118-7007	1	Camshaft
④92009	92009-2341	4	Screw
④92015	92015-2253	4	Nut
④92033	92033-7001	2	Ring-Snap
④92140	92140-7002	6	Ball
④92145	92145-7001	1	Spring
④92153	92153-7019	4	Bolt
④92200	92200-7001	1	Washer

--	--	--	--

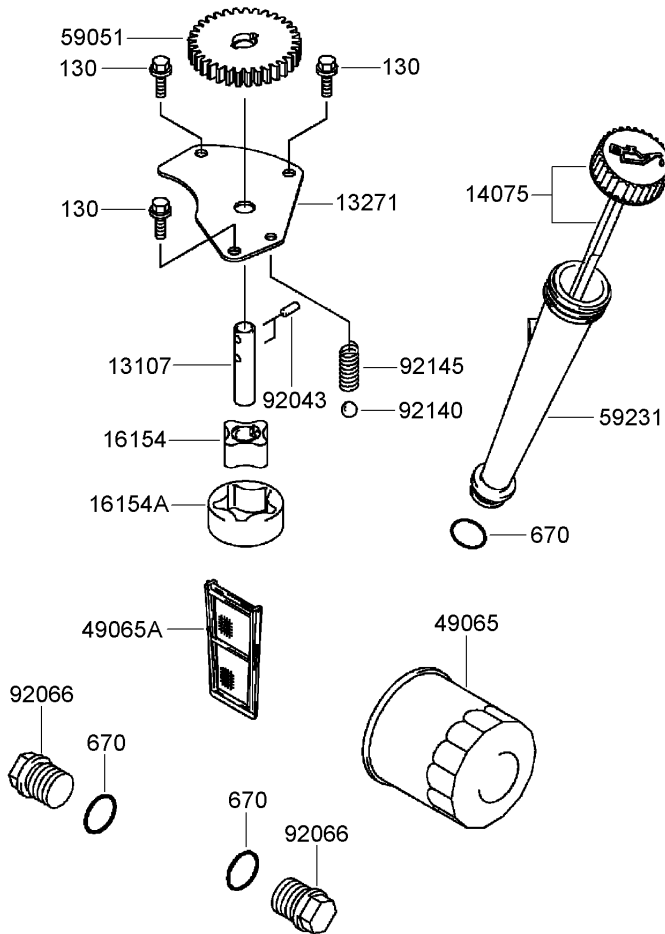

Lubrication Equipment Assembly Kawasaki FH680V-DS21

Ref	Part No.	Qty.	Description
④13107	13107-7009	1	Shaft
④13271	13271-7005	1	Plate
④14075	14075-7008	1	Cap ASM
④16154	16154-7007	1	Rotor-Pump (In)
④16154A	16154-7008	1	Rotor-Pump (Out)
④49065	49065-2078	1	Filter-Oil
④49065A	49065-7003	1	Filter-Oil
④59051	59051-7011	1	Gear-Spur
④59231	59231-7006	1	Filler
④92043	92043-7003	2	Pin
④92066	92066-7003	2	Plug
④92140	92140-7003	1	Ball
④92145	92145-7002	1	Spring
④130	130B0612	3	Bolt-Flanged (6X12)
④670	670D2016	3	O-Ring (16Mm)

--	--	--	--

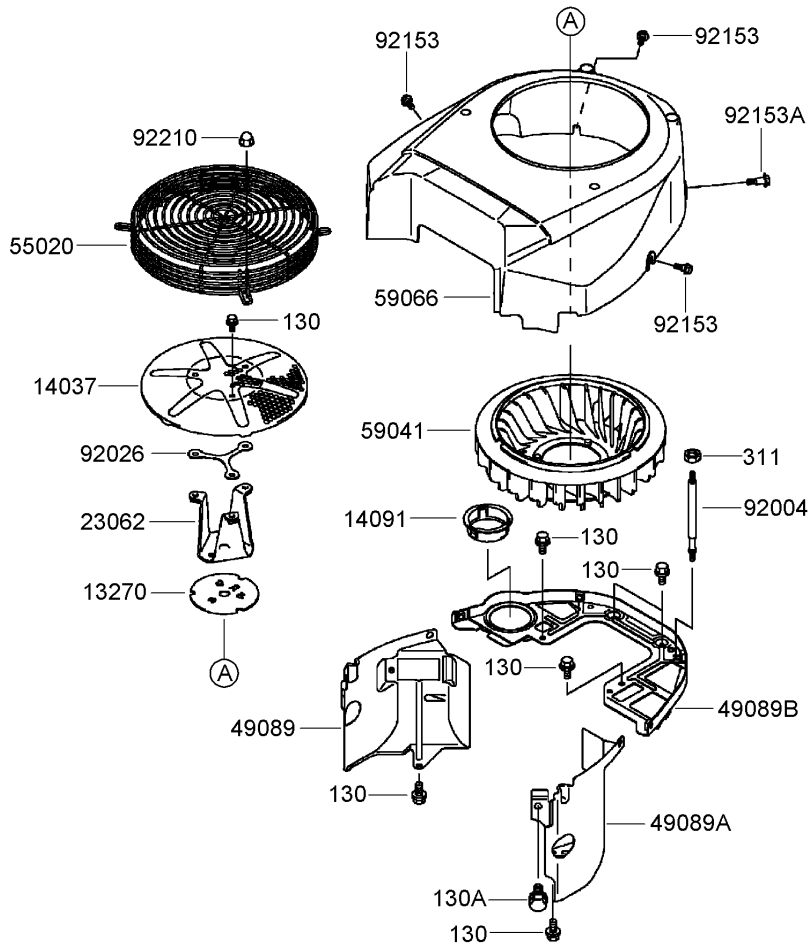

Cooling Equipment Assembly Kawasaki FH680V-DS21

Ref	Part No.	Qty.	Description
④13270	13270-7007	1	Plate
④14037	14037-7008-9H	1	Screen
④14091	14091-7002	1	Cover
④23062	23062-7005	1	Bracket
④49089	49089-7004	1	Shroud-Engine
④49089A	49089-7005	1	Shroud-Engine
④49089B	49089-7049	1	Shroud-Engine
④55020	55020-7007	1	Guard
④59041	59041-7003	1	Fan
④59066	59066-7004	1	Housing-Fan
④92004	92004-7006	2	Stud
④92026	92026-7007	1	Spacer
④92153	92153-7007	3	Bolt
④92153A	92153-7008	1	Bolt
④92210	92210-0003	4	Nut
④130	130B0612	9	Bolt-Flanged (6X12)
④130A	130B0816	1	Bolt-Flanged (8X16)
④311	311B0600	2	Nut-Hex (6Mm)

--	--	--	--

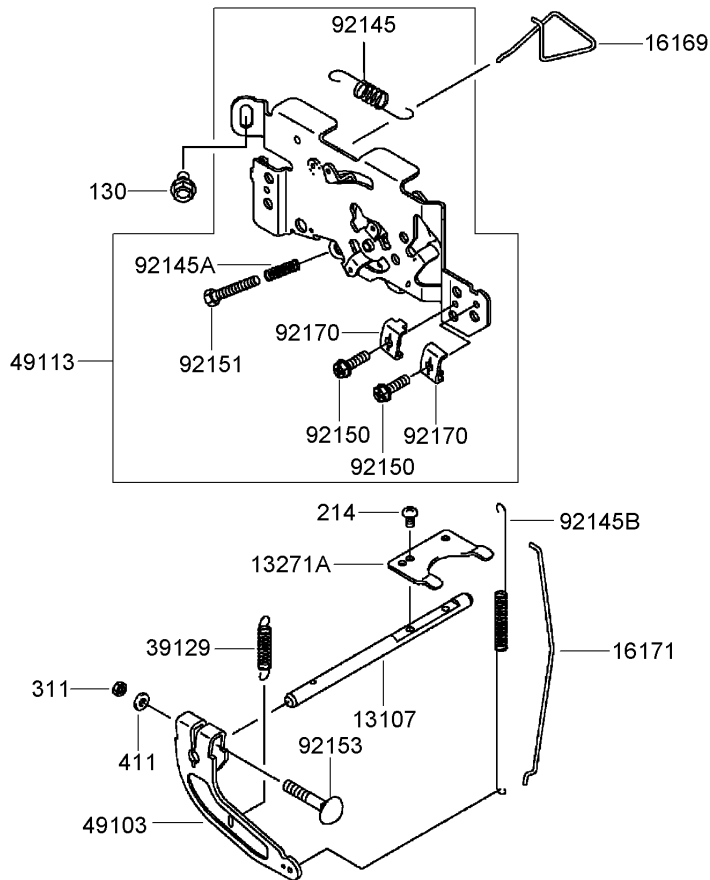

Control Equipment Assembly Kawasaki FH680V-DS21

Ref	Part No.	Qty.	Description				
④13107	13107-7013	1	Shaft				
④13271A	13271-7032	1	Plate				
④16169	16169-7006	1	Link-Choke				
④16171	16171-7004	1	Link				
④39129	39129-7004	1	Spring-Governor				
④49103	49103-7004	1	Arm-Governor				
④49113	49113-7017	1	Panel-Control				
④92145	92145-7004	1	Spring				
④92145A	92145-7005	1	Spring				
④92145B	92145-7034	1	Spring				
④92150	92150-2182	2	Bolt (5X18)				
④92151	92151-7014	1	Bolt (5X30)				
④92153	92153-7033	1	Bolt (6X35)				
④92170	92170-7001	2	Clamp				
④130	130B0612	2	Bolt-Flanged (6X12)				
④214	214B0408	2	Screw-Pan (4X8)				
④311	311B0600	1	Nut-Hex (6Mm)				
④411	411B0600	1	Washer-Plain (6Mm)				

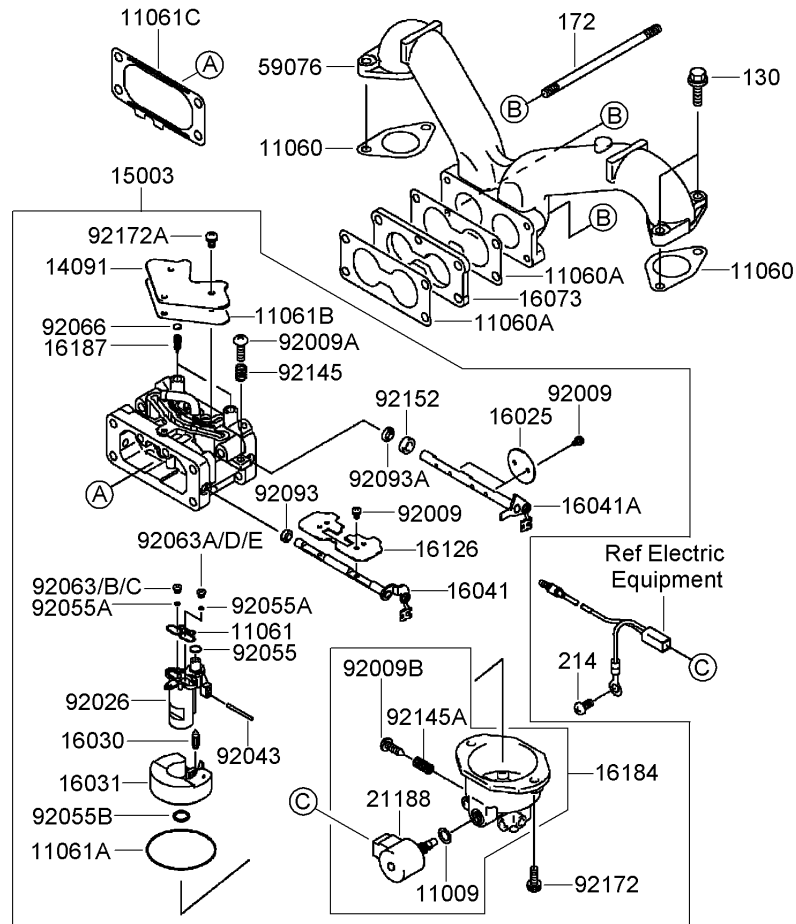

Carburetor Assembly Kawasaki FH680V-DS21

Ref	Part No.	Qty.	Description
④11009	11009-2056	1	Gasket
④11060	11060-7011	2	Gasket-Manifold
④11060A	11060-7024	2	Gasket-Carburetor
④11061	11061-7037	1	Gasket
④11061A	11061-7038	1	Gasket
④11061B	11061-7039	1	Gasket
④11061C	11061-7043	1	Gasket
④14091	14091-7031	1	Cover
④15003	15003-7120	1	Carburetor ASM
④16025	16025-7003	2	Valve-Throttle
④16030	16030-7004	1	Valve-Float
④16031	16031-7003	1	Float
④16041	16041-7021	1	Shaft-Carburetor
④16041A	16041-7024	1	Shaft-Carburetor
④16073	16073-7005	1	Insulator
④16126	16126-7015	1	Valve
④16184	16184-7017	1	Chamber Float ASM
④16187	16187-7002	2	Needle-Jet
④21188	21188-7003	1	Solenoid
④59076	59076-7002	1	Manifold-Intake
④92009	92009-7003	6	Screw
④92009A	92009-7004	1	Screw
④92009B	92009-7006	1	Screw-Drain
④92026	92026-7011	1	Spacer

Ref	Part No.	Qty.	Description
④92043	92043-7014	1	Pin
④92055	92055-7012	1	O-Ring
④92055A	92055-7013	2	O-Ring
④92055B	92055-7016	1	O-Ring
④92063	92063-7051	1	Jet-Main, No.104
④92063A	92063-7054	1	Jet-Main, No.108
④92063B	92063-7075	1	Jet-Main, No.101 (3280)
④92063C	92063-7076	1	Jet-Main, No.098 (6560)
④92063D	92063-7077	1	Jet-Main, No.105 (3280)
④92063E	92063-7078	1	Jet-Main, No.102 (6560)
④92066	92066-7009	2	Plug, Extension
④92093	92093-7001	1	Seal (I D 5.9)
④92093A	92093-7002	1	Seal (I D 6.9)
④92145	92145-7010	1	Spring
④92145A	92145-7011	1	Spring
④92152	92152-7005	1	Collar
④92172	92172-7005	2	Screw
④92172A	92172-7006	3	Screw
④130	130B0620	4	Bolt-Flanged (6X20)
④172	172G06105	2	Bolt-Stud (6X10.5)
④214	214B0510	1	Screw-Pan (5X10)

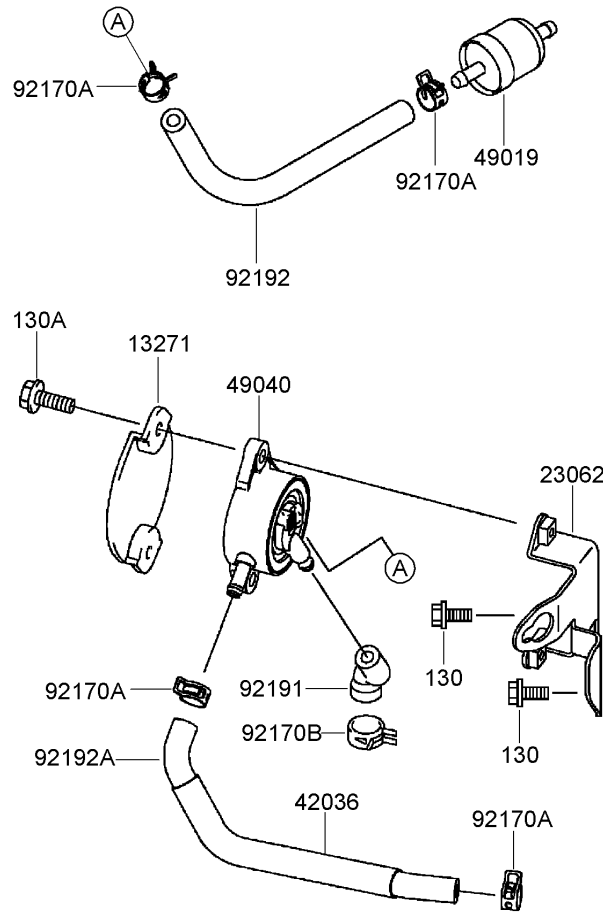

Fuel Tank and Valve Assembly Kawasaki FH680V-DS21

Ref	Part No.	Qty.	Description
④13271	13271-7004	1	Plate
④23062	23062-7004-9H	1	Bracket
④42036	42036-7012	1	Sleeve
④49019	49019-7001	1	Filter-Fuel
④49040	49040-7001	1	Pump-Fuel
④92170A	92170-2088	4	Clamp
④92170B	92170-7003	1	Clamp
④92191	92191-7027	1	Tube
④92192	92192-7037	1	Tube (6.35X12.7X160)
④92192A	92192-7039	1	Tube (6.35X12.7X200)
④130	130B0616	2	Bolt-Flanged (6X16)
④130A	130B0620	2	Bolt-Flanged (6X20)

Attachments and Accessories

For 74417 - Z450 Z Master, With 48in TURBO FORCE Side Discharge Mower

Product Name	Model/Part
Striping Kit	106-3370
Suspension Kit for Standard Seat	107-1892
48 Inch Standard High Lift Blade	107-3192-03
Blade-Low Flow, 16.5 Inch	107-3193-03
Blade-Mid Flow, 16.5 Inch	107-3194-03
Blade-Atomic, 16.5 Inch	107-3195-03
Blade-Recycling, 16.5 Inch	107-3196-03
Z Stand Kit	107-8599
Recycler Kit	108-2209
Mower Deck Lift Assist Kit	108-4090
Bagging Enhancement Kit	108-4091
Blade-Hi Flow, 16.5 Inch (6 Pack)	110-0414
Blade-Lo Flow, 16.5 Inch (6 Pack)	110-0415
Blade-Recycler, 16.5 Inch (6 Pack)	110-0416
Blade-Atomic, 16.5 Inch (6 Pack)	110-0417
Blade-Mid Flow, 16.5 Inch (6 Pack)	110-0418
Bimini Sunshade	110-5726
Channel Reinforcement Kit	112-8673
DFS Vac Collection System	78510
Chute Gate Kit	78521
Deluxe Suspension Seat Kit	78530
Twin Bagger ASM	78531
Blower and Drive Kit	78536
Hitch Kit	99-8924

NOTES

