



Z400 Z Master[®] With 48in 7-Gauge Side Discharge Mower

Model No. 74418 - 270002001 and up.

Parts Catalog

Ordering Replacement Parts

To order replacement parts, please supply the part number, the quantity, and the description of each part desired.

Understanding Reference Numbers

Each identified part in an illustration has a reference number. The reference number for a part also appears in the parts list, along with other information about the part.

This catalog uses two special reference number formats, one to indicate parts in a service assembly and another to indicate the quantity of a given part in an illustration.

Service Assembly Reference Numbers

Parts in service assemblies have reference numbers in the form a:b. The a represents the reference number of the entire service assembly and the b represents a sequential number unique to each part within the service assembly.

For example, a wheel assembly might be identified by reference number 6, the tire by 6:1, the valve by 6:2, and the wheel by 6:3. When you order the assembly identified by reference number 6, you receive all parts identified by reference numbers 6:1, 6:2, and 6:3. However, you may also order any part individually. Reference numbers of this type appear in illustrations and in part lists.

Reference Numbers Indicating Quantity

In an illustration, if a reference number indicates more than one part, the reference number has the form nX y. The n represents the quantity of the part, the X is the multiplication symbol, and the y represents the reference number.

For example, in an illustration, the reference number 2X 37 means that two of the parts identified by reference number 37 are indicated.

Contents

Description	Page	Description	Page
Front Frame Assembly	3	Roll-Over Protection System Assembly No. 107-8093	26
Height-of-Cut Assembly	4	Fuel Tank / Fuel Valve Assembly Kawasaki FH580V AS30	27
Main Frame Assembly	5	Cylinder / Crankcase Assembly Kawasaki FH580V AS30	28
Fuel System Assembly	6	Piston / Crankshaft Assembly Kawasaki FH580V AS30	30
Parking Brake Assembly	7	Valve / Camshaft Assembly Kawasaki FH580V AS30	32
Motion Control Assembly	8	Lubrication Equipment Assembly Kawasaki FH580V AS30	34
Left Hand Motion Control Assembly No. 109-3912	9	Cooling Equipment Assembly Kawasaki FH580V AS30	36
Right Hand Motion Control Assembly No. 109-3911	10	Electric Equipment Assembly Kawasaki FH580V AS30	38
Hydraulic System Assembly	11	Control Equipment Assembly Kawasaki FH580V AS30	40
Pump Idler and Belt Assembly	13	Carburetor Assembly Kawasaki FH580V AS30	42
Engine, Clutch and Muffler Assembly	14	Air Filter / Muffler Assembly Kawasaki FH580V AS30	44
Deck Connection Assembly	15	Starter Assembly Kawasaki FH580V AS30	46
Deck Assembly	16	Label Assembly Kawasaki FH580V AS30	48
Deck Decal Assembly No. 107-1666	18	Attachments and Accessories List	49
Spindle Assembly No. 107-8504	19		
Rubber Deflector Assembly No. 108-7770	20		
Idler Assembly	21		
Electrical Assembly	22		
Seat and Bracket Assembly	23		
Seat Assembly No. 110-5738	24		
Roll-Over Protection System Assembly	25		

Part Description Abbreviations

Part descriptions in this catalog may include the following abbreviations.

AR. as required	HYD. hydraulic
ASM. assembly	LH. left hand
BBC. blade brake clutch	NI. nylon insert
CARR. carriage	NPTF. national pipe thread fine
DEG. degrees	PFH. phillips flat head
EXT. external	PPH. phillips pan head
FH. flat head	PPHTF. phillips pan head thread forming
GA. gauge	PRH. phillips round head
HD. heavy-duty	PTH. phillips truss head
HF. hex flange	PTO. power-take-off
HH. hex head	RH. right hand
HHF. hex head flange	ROPS. roll-over protection system
HHFTF. hex head flange thread forming	SFH. slotted fillister head
HJ. hex jam	SHH. slotted hex head
HLH. hex lag head	SHWH. slotted hex washer head
HOC. height-of-cut	SPH. slotted pan head
HSBH. hex socket button head	SQH. square head
HSFH. hex socket flat head	SRH. slotted round head
HSH. hex socket head	STD. standard
HWH. hex washer head	TAP. self tapping
HWHTF. hex washer head thread forming	TTH. torx truss head

Footnotes

- | | |
|----------------------|--|
| ❶ Not illustrated | ❷ Not serviced separately |
| ❸ Optional Equipment | ❹ Obtain from your local Kawasaki dealer |

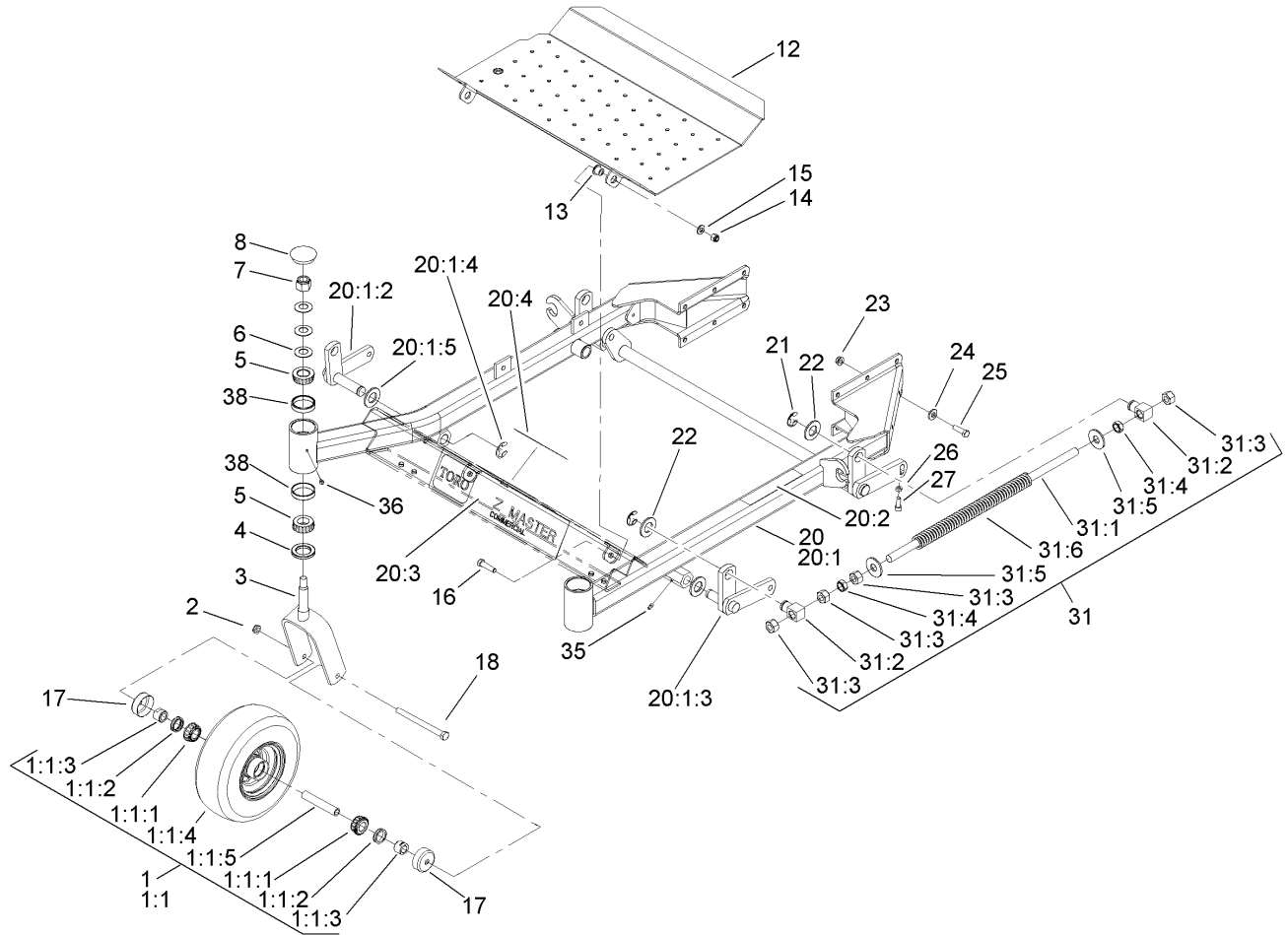

Front Frame Assembly

Ref	Part No.	Qty.	Description
1	103-3800	2	Wheel And Tire ASM
② 1:1		1	Wheel And Bearing ASM
1:1:1	1-633585	2	Bearing-Cone, Taper
1:1:2	103-0063	2	Seal-Caster
1:1:3	103-3051	2	Spacer-Nut
1:1:4	103-3151	1	Wheel And Tire ASM
1:1:5	103-3157	1	Axle-Caster
2	3296-45	2	Nut-Lock, NI
3	108-7724-01	2	Caster Fork ASM
4	1-543511	2	Seal-Grease
5	254-94	4	Bearing-Cone, Tapered
6	1-633508	6	Washer-Bellville
7	3296-51	2	Nut-Lock, NI
8	103-4882	2	Cap-Grease
12	108-5007-03	1	Floor Pan
13	86-2180	2	Bushing-Flange
14	3296-39	2	Nut-Lock, NI
15	3256-24	2	Washer-Flat
16	323-8	2	Screw-HH
17	103-2768	4	Guard-Seal
18	325-20	2	Screw-HH
20	108-7744	1	Front Frame ASM
② 20:1		1	Frame-Front
20:1:2	99-3872	1	RH Lift Arm ASM

Ref	Part No.	Qty.	Description
20:1:3	99-3871	1	LH Lift Arm ASM
20:1:4	32151-103	2	Ring-Snap
20:1:5	3256-29	2	Washer-Flat
20:2	1-633818	1	Decal-Warning
20:3	106-7451	1	Decal
20:4	107-2112	1	Decal-Warning
21	32151-103	4	Ring-Snap
22	3256-29	4	Washer-Flat
23	3290-357	12	Nut-HHF, Whiz
24	98-5975	12	Washer-Belleville
25	323-7	12	Screw-HH
26	3218-2	2	Nut-Jam
27	3274-18	2	Screw-HSH
31	1-634439	2	Front Frame Spring ASM
31:1	1-633096	1	Rod-Lift, Deck
31:2	1-633441	2	Swivel-Deck Mount, Rear
31:3	3217-11	4	Nut-Hex
31:4	3218-6	2	Nut-Jam
31:5	3256-7	2	Washer-Flat
31:6	1-633064	1	Spring-Support, Deck
35	302-19	4	Fitting-Grease
36	302-5	2	Fitting-Grease
38	254-72	4	Bearing-Cup, Tapered

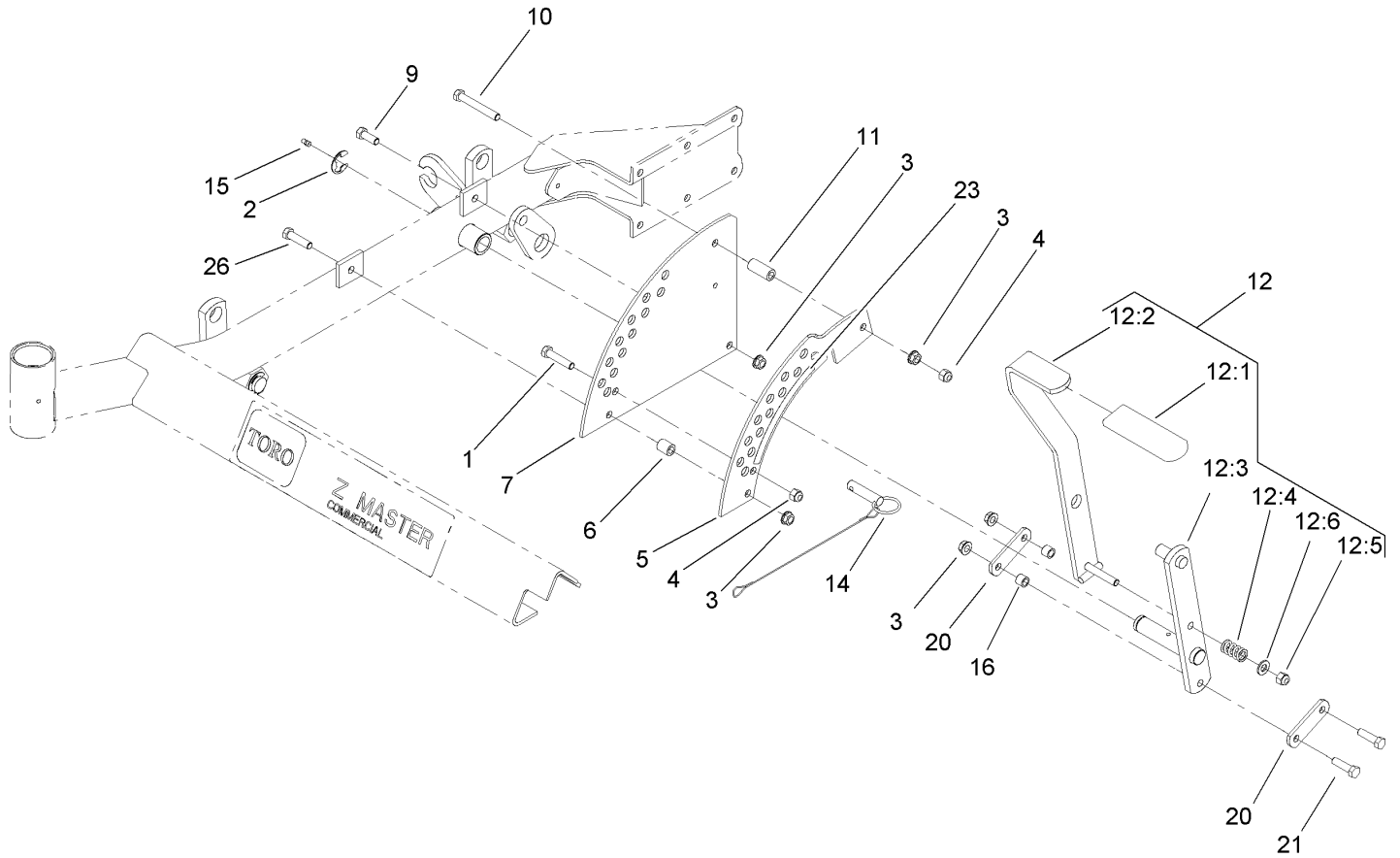

Height-of-Cut Assembly

Ref	Part No.	Qty.	Description
1	323-9	1	Screw-HH
2	32151-103	1	Ring-Snap
3	3290-357	5	Nut-HHF, Whiz
4	3296-39	2	Nut-Lock, NI
5	108-7755-01	1	Plate-Lift, Deck
6	1-633080	1	Bushing-Lever, Lift
7	1-653230-01	1	Plate-Lift, Deck
9	323-6	1	Screw-HH
10	323-13	1	Screw-HH
11	1-633082	1	Bushing-Lever, Lift
12	110-5870	1	Deck Lift Handle ASM
12:1	1-633295	1	Grip-Lever, Lift
12:2	103-2078	1	Handle-Lift
12:3	106-6598	1	Lift Arm ASM
12:4	1-633325	1	Spring-Compression
12:5	3296-39	1	Nut-Lock, NI
12:6	3256-24	1	Washer-Flat
14	106-9951	1	Hitch Pin ASM
15	302-19	1	Fitting-Grease
16	103-1918	2	Bushing
20	1-633068	2	Arm-Lift, Deck
21	323-29	2	Screw-HH
23	108-1050	1	Decal-Deck Height, Inner
26	323-8	1	Screw-HH

Ref	Part No.	Qty.	Description

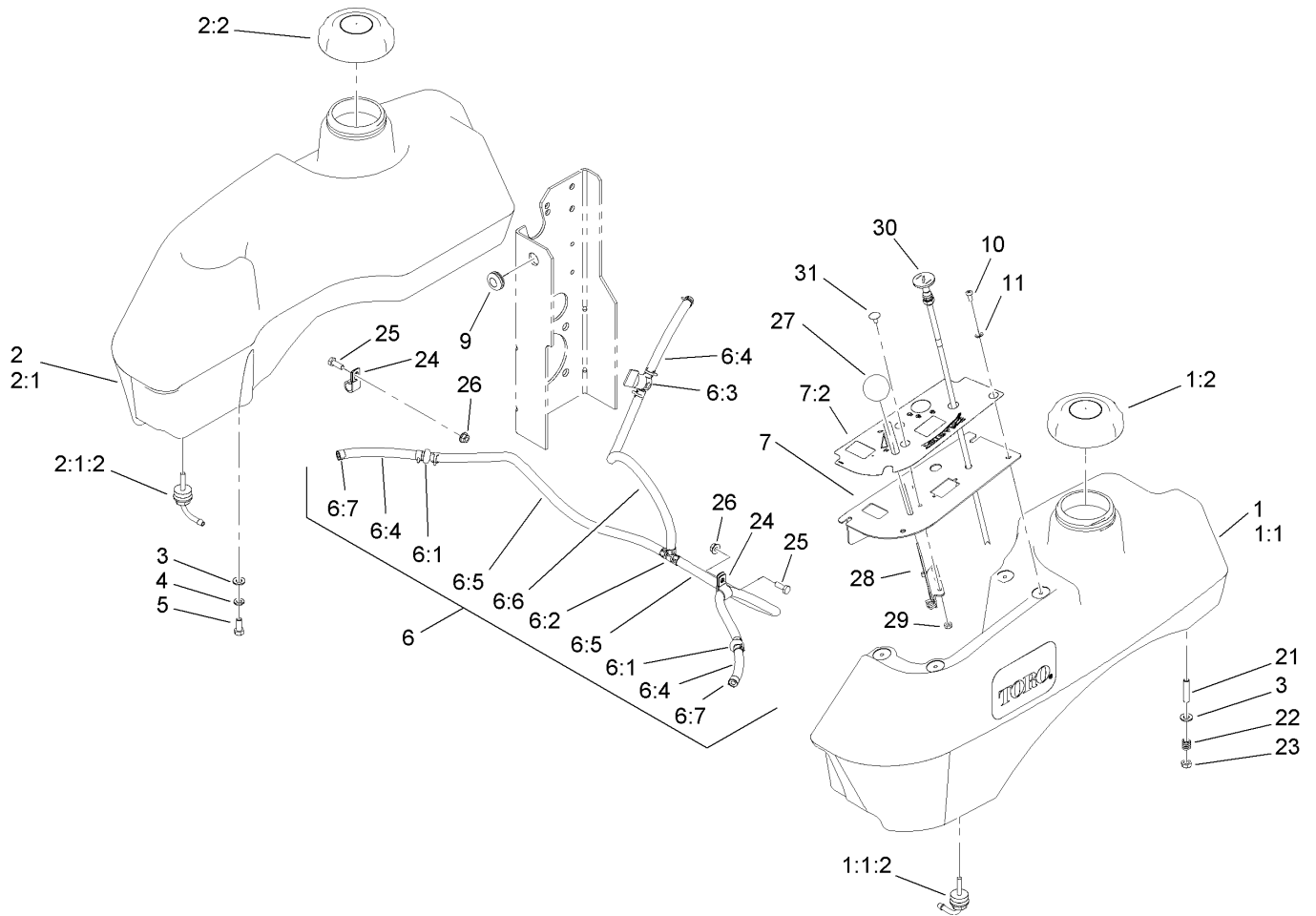

Fuel System Assembly

Ref	Part No.	Qty.	Description
1	110-4165	1	LH Fuel Tank Service Kit
② 1:1		1	Tank-Fuel, LH
1:1:2	103-2605	1	Fitting-Fuel, Bulkhead
1:2	109-0346	1	Cap-Fuel, Gas
2	105-3639	1	RH Fuel Tank Service Kit
② 2:1		1	Tank-Fuel, RH
2:1:2	103-2605	1	Fitting-Fuel, Bulkhead
2:2	109-0346	1	Cap-Fuel, Gas
3	3256-23	8	Washer-Flat
4	1-805005	4	Washer-Lock
5	322-3	4	Screw-HH
② 6		1	Fuel Line ASM
6:1	99-5000	2	Valve-Check, Fuel
6:2	99-5005	1	Fitting-Tee, Barbed
6:3	1-603770	1	Valve-Fuel
6:4	109-0678	3	Hose-Fuel
6:5	110-5701	2	Hose-Fuel
6:6	109-0297	1	Hose-Fuel
6:7	1-303077	12	Clamp
7	107-2149	1	Control Panel ASM
7:2	110-0439	1	Decal-Panel, Control
9	1-543296	2	Grommet
10	1-803071	4	Screw
11	1-303435	4	Washer-Spring

Ref	Part No.	Qty.	Description
21	1-633023	4	Stud
22	1-633349	4	Spring-Tank, Fuel
23	3296-47	4	Nut-Lock, NI
24	1-513762	4	Clip-Loom
25	321-4	2	Screw-HH
26	32128-33	2	Nut-HF
27	1-513592	1	Knob-Ball
28	1-633696	1	Throttle Cable ASM
29	3296-2	2	Nut-Lock
30	106-9962	1	Control-Choke, Push / Pull
31	1-807513	2	Bolt-CARR

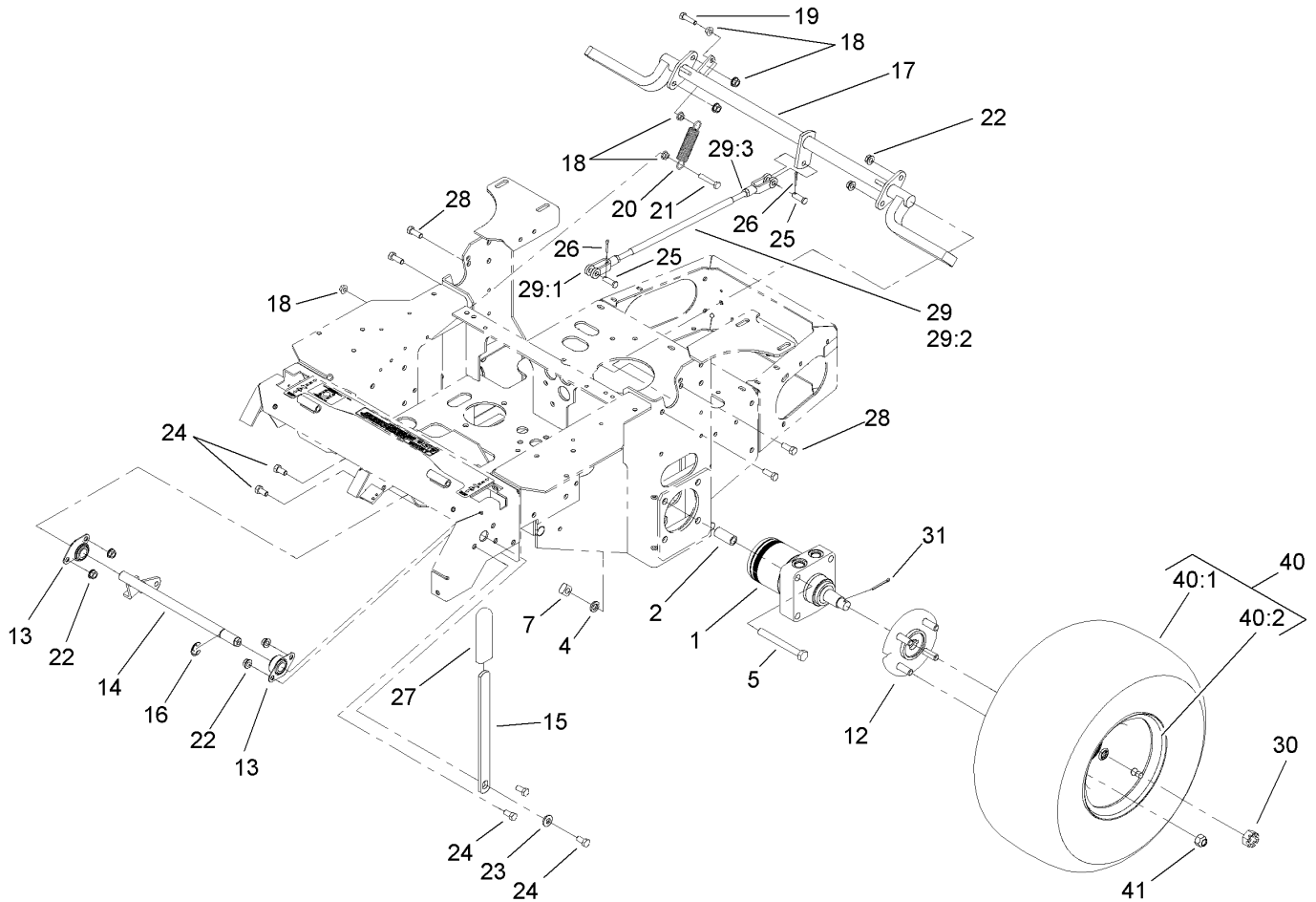

Parking Brake Assembly

Ref	Part No.	Qty.	Description
1	103-4695	2	Motor-Wheel
❶1:1	1-000119	1	Seal Kit
❶1:2	1-000138	1	Bearing Kit
2	103-8503	8	Spacer-Motor, Wheel
4	3253-7	8	Washer-Lock
5	325-18	8	Screw-HH
7	103-0131	8	Nut-Square
12	110-5812	2	Wheel Hub ASM
13	1-633102	2	Bearing-Flange, Side
14	103-3116	1	Shaft-Brake, Parking
15	107-9255-03	1	Handle-Brake, Parking
16	32151-48	1	E-Ring
17	103-3960-03	1	Brake
18	32128-20	4	Nut-HF
19	322-6	1	Screw-HH
20	1-323161	1	Spring-Idler
21	322-9	1	Screw-HH
22	3290-357	8	Nut-HHF, Whiz
23	98-5975	1	Washer-Belleville
24	323-4	5	Screw-HH
25	1-808285	2	Pin-Clevis
26	3272-10	2	Pin-Cotter
27	1-633268	1	Grip-Lever, Brake
28	323-6	4	Screw-HH

Ref	Part No.	Qty.	Description
29	103-4335	1	Brake Rod ASM
29:1	1-633131	2	Yoke-Linkage, Brake
29:2	103-3907	1	Linkage-Handle, Brake
29:3	3219-3	2	Nut-Hex
30	32136-5	2	Nut-Hex, Slotted
31	1-806800	2	Pin-Cotter
40	1-543396	2	Wheel And Tire ASM
40:1	1-543680	1	Tire
40:2	1-513042	1	Wheel
41	242-50	8	Nut-Lug

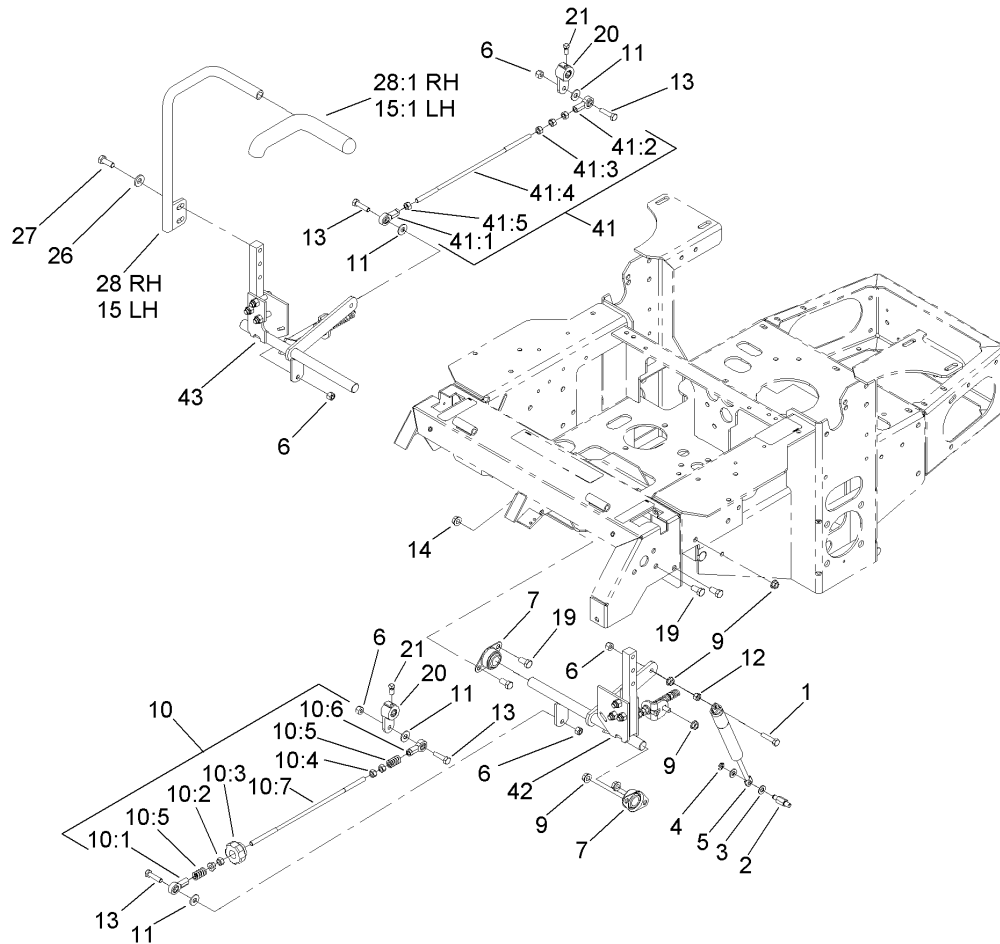

Motion Control Assembly

Ref	Part No.	Qty.	Description
1	1-403180	2	Screw-HH
2	103-4101	2	Pin-Damper
3	3256-23	4	Washer-Flat
4	32120-35	2	Ring-Retaining, EXT
5	109-2339	2	Damper-Control, Motion
6	3296-29	6	Nut-Lock, NI
7	1-633102	4	Bearing-Flange, Side
9	32128-20	10	Nut-HF
10	103-4326	1	Tracking Rod ASM
10:1	1-543017	1	Balljoint-RH
10:2	3219-2	1	Nut-Hex
10:3	103-3060	1	Knob-Tracking
10:4	1-804524	2	Nut
10:5	1-323245	2	Spring-Compression
10:6	1-633152	1	Balljoint-LH
10:7	103-3066	1	Link-Rod, Tracking
11	3256-3	4	Washer-Flat
12	3217-6	2	Nut-Hex
13	322-6	4	Screw-HH
14	3290-357	6	Nut-HHF, Whiz
15	103-0631	1	LH Lever ASM
15:1	1-633257	1	Grip-Control, Motion
19	323-4	6	Screw-HH
20	103-3717	2	Arm-Control

Ref	Part No.	Qty.	Description
21	1-803022	2	Screw-Set
26	98-5975	4	Washer-Belleville
27	323-6	4	Screw-HH
28	103-0632	1	RH Lever ASM
28:1	1-633257	1	Grip-Control, Motion
41	103-4327	1	Tracking ASM
41:1	1-543017	1	Balljoint-RH
41:2	1-633152	1	Balljoint-LH
41:3	1-804524	1	Nut
41:4	103-3066	1	Link-Rod, Tracking
41:5	3219-2	3	Nut-Hex
42	109-3912	1	LH Motion Control ASM
43	109-3911	1	RH Motion Control ASM

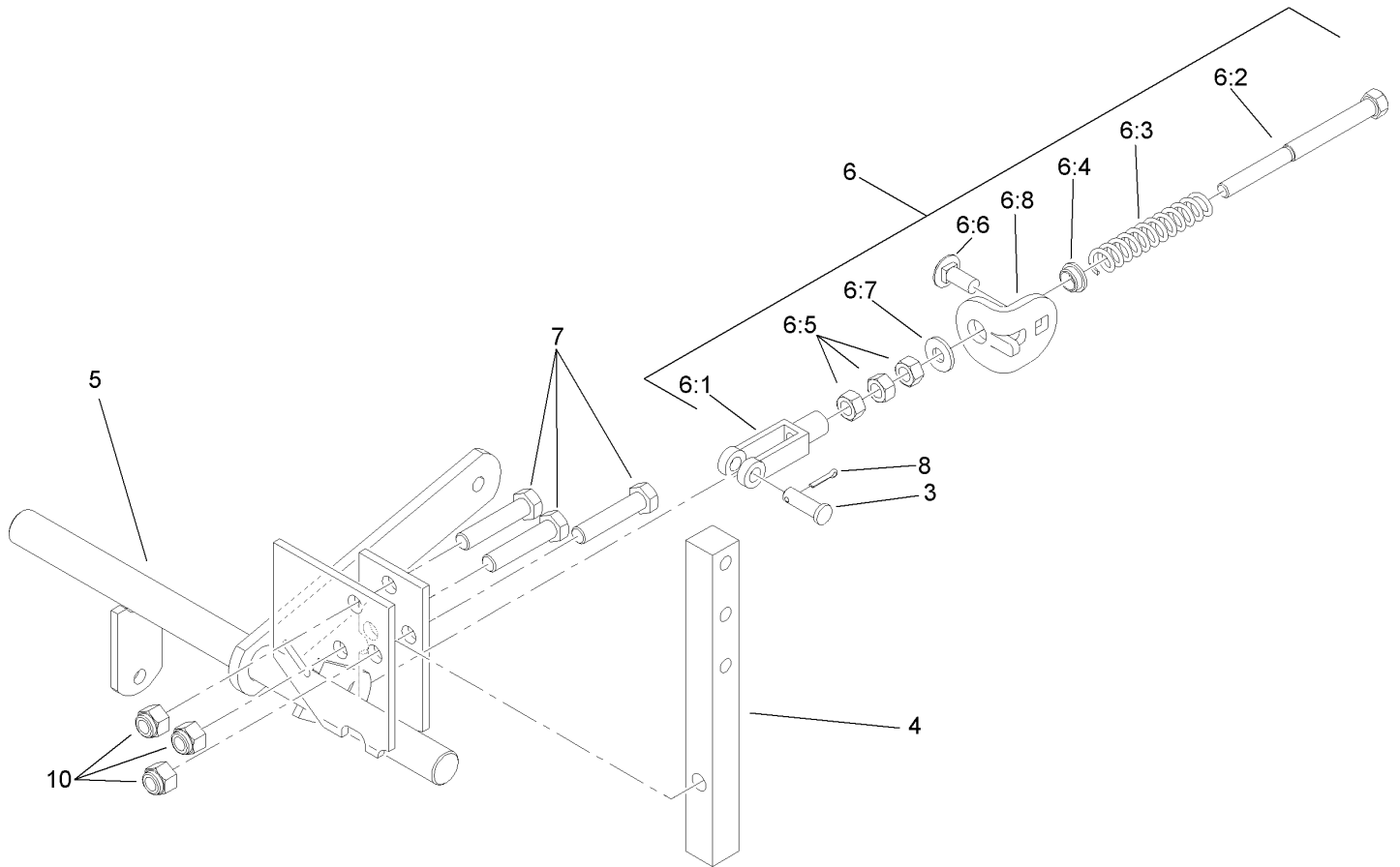

Left Hand Motion Control Assembly No. 109-3912

Ref	Part No.	Qty.	Description
3	1-808280	1	Pin-Clevis
4	103-0407	1	Arm-Shaft, Control
5	103-4774	1	Control-Motion, LH
6	109-3903	1	Neutral Return ASM
6:1	1-303105	1	Yoke-Adjustable
6:2	1-603737	1	Bolt-Return, Neutral
6:3	1-603807	1	Spring-Return, Neutral
6:4	109-3769	1	Bushing-Nylon, Flanged
6:5	3219-2	3	Nut-Hex
6:6	3230-23	1	Screw-CARR
6:7	3256-2	1	Washer-Flat
6:8	109-3908	1	Tab-Adjustment
7	323-9	3	Screw-HH
8	3272-5	1	Pin-Cotter
10	3296-39	3	Nut-Lock, NI

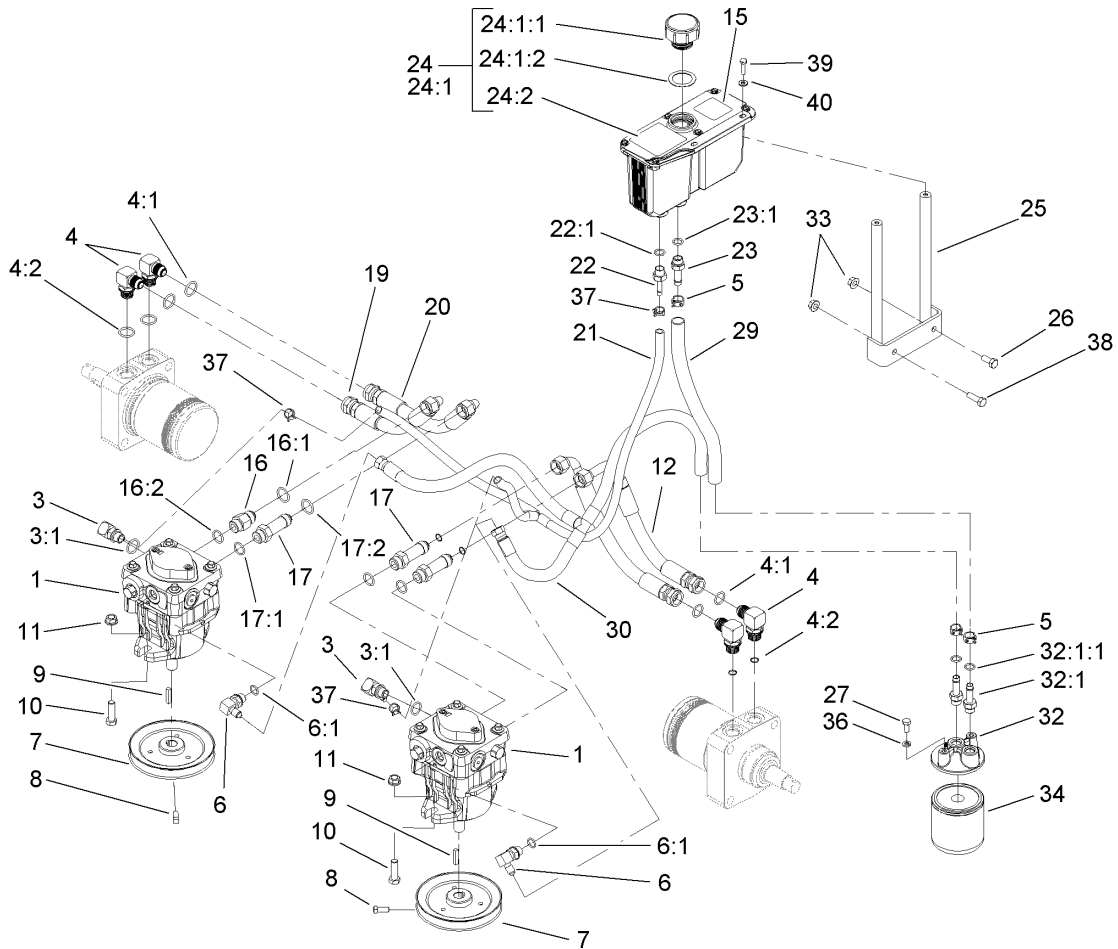

Hydraulic System Assembly

Ref	Part No.	Qty.	Description
1	103-4040	2	Pump-HYD
1:1	105-6184	1	Overhaul Seal Kit
1:2	105-6185	1	Plate-Valve
1:3	103-2664	1	Input Shaft Kit
1:4	94-6922	1	Bearing-Thrust
1:5	103-2666	1	Cylinder Block Kit
1:7	106-2053	1	Shock Valve Kit
3	103-1799	2	Elbow-90 DEG
3:1	237-42	1	O-Ring
4	103-2153	4	Fitting-90 DEG
4:1	1-603920	1	O-Ring
4:2	1-603992	1	O-Ring
5	103-1988	3	Clamp-Hose
6	103-1802	2	Fitting-HYD, 90 DEG
6:1	1-603921	1	O-Ring
7	1-653156	2	Pulley
8	1-803050	2	Screw-Set
9	1-807272	2	Key
10	323-7	4	Screw-HH
11	3290-357	5	Nut-HHF, Whiz
12	103-4022	1	Hose-Rear, LH
15	103-2644	1	Decal-Exhaust
16	103-4020	1	Adapter-Straight
16:1	1-603920	1	O-Ring

Ref	Part No.	Qty.	Description
16:2	1-603992	1	O-Ring
17	103-1940	3	Adapter-HYD, Straight
17:1	237-79	1	O-Ring
17:2	1-603992	1	O-Ring
19	103-4021	1	Hose-Rear, RH
20	1-653187	2	Hose-Rear, RH
21	103-2357	1	HYD Hose ASM
22	103-1801	1	Adapter-Straight
22:1	237-42	1	O-Ring
23	103-1912	1	Adapter-Straight
23:1	237-42	1	O-Ring
24	103-1947	1	HYD Reservoir ASM
24:1		1	Reservoir-HYD
24:1:1	103-1948	1	Cap-Reservoir, HYD
24:1:2	103-1949	1	Gasket-Cap
24:2	1-523552	1	Decal-Tank, HYD
25	103-3071-03	1	Stand-Reservoir
26	322-3	1	Screw-HH
27	321-3	2	Screw-HH
29	103-3077	1	HYD Hose ASM
30	103-2930	1	HYD Hose ASM
32	103-2889	1	Filter Head ASM
32:1	103-1912	2	Adapter-Straight
32:1:1	237-42	1	O-Ring

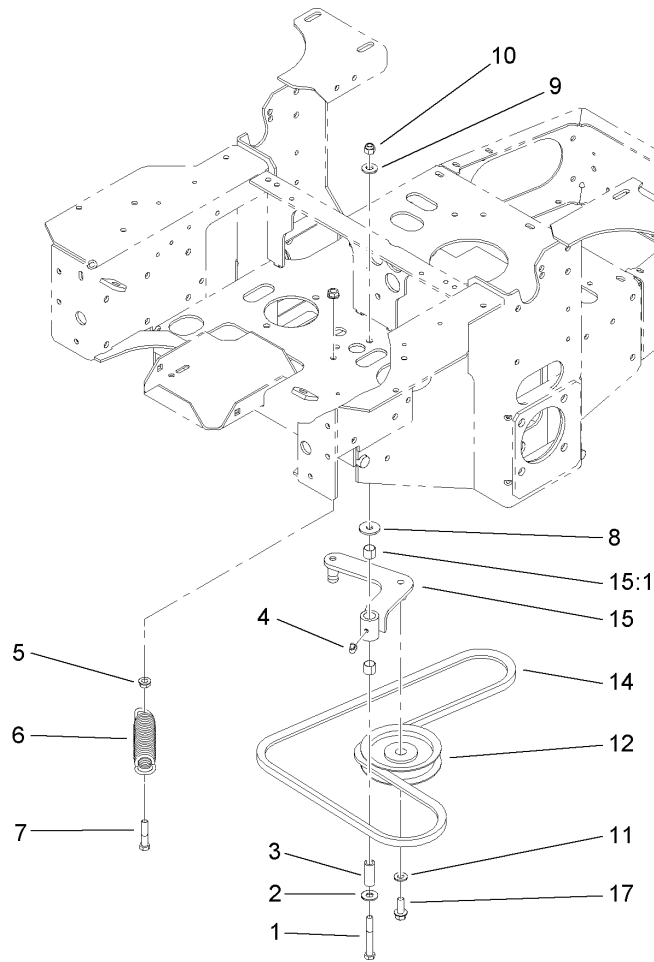

Pump Idler and Belt Assembly

Ref	Part No.	Qty.	Description
1	323-13	1	Screw-HH
2	3256-4	1	Washer-Flat
3	1-603044	1	Bushing
4	302-40	1	Fitting-Grease
5	3290-357	2	Nut-HHF, Whiz
6	103-4480	1	Spring-Extension
7	323-9	1	Screw-HH
8	63-8410	1	Washer
9	98-5975	1	Washer-Belleville
10	3296-39	1	Nut-Lock, NI
11	3256-24	1	Washer-Flat
12	1-603843	1	Pulley-Idler
14	107-3959	1	Belt-Cog
15	103-4482	1	Idler Arm ASM
15:1	103-4681	2	Sleeve-Bearing
17	3234-11	1	Screw-HHF

--	--	--	--

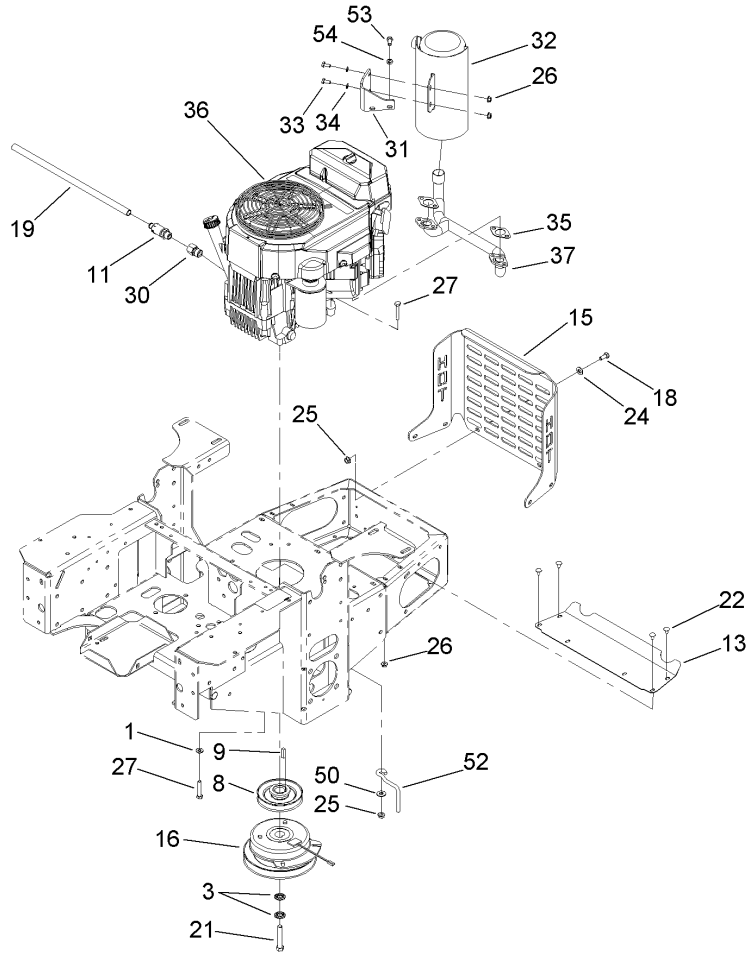

Engine, Clutch and Muffler Assembly

Ref	Part No.	Qty.	Description
1	1-303334	4	Washer-Spring
3	1-603610	2	Washer-Spring
8	1-653035	1	Pulley
9	1-807259	1	Key
11	92-6877	1	Valve-Drain, Oil
13	103-2740-03	1	Deflector-Short
15	103-4048-03	1	Bumper-Rear
16	104-3624	1	Clutch
18	322-3	6	Screw-HH
19	106-7022	1	Tube-Drain, Oil
21	3212-10	1	Screw-HH
22	3229-10	4	Screw-CARR
24	3256-24	6	Washer-Flat
25	32128-20	11	Nut-HF
26	32128-33	6	Nut-HF
27	322-9	5	Screw-HH
30	103-1966	1	Adapter
31	103-4578-03	1	Bracket-Muffler
32	103-8106	1	Muffler
33	321-3	2	Screw-HH
34	1-303435	2	Washer-Spring
35	1-653290	2	Gasket
36		1	Engine-Kawasaki, FH580V-As30
37	103-4577	1	Manifold-Exhaust

Ref	Part No.	Qty.	Description
50	3256-3	1	Washer-Flat
52	108-1058	1	Rod-Belt
53	33114-020	2	Screw-HH
54	1-805005	2	Washer-Lock

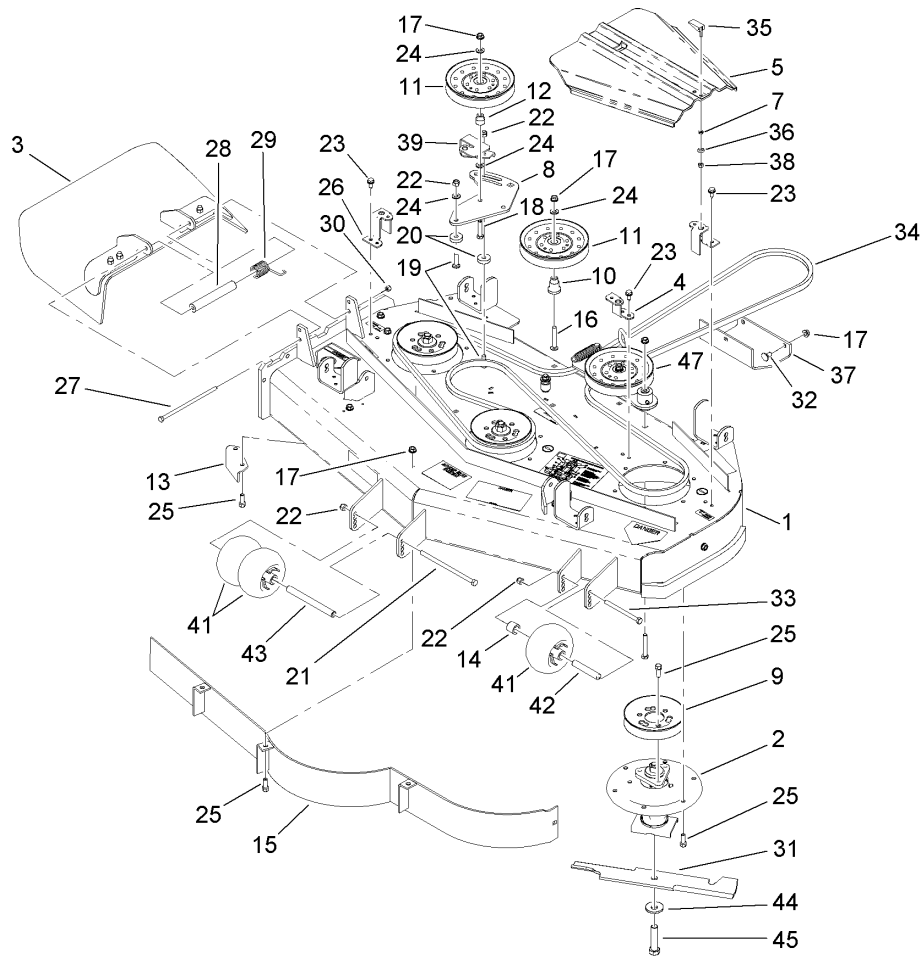

Deck Assembly

Ref	Part No.	Qty.	Description
1	107-1666	1	Deck Decal ASM
2	107-8504	3	Spindle ASM
3	108-7770	1	Rubber Deflector ASM
4	108-2177-01	1	Bracket-Cover, Tall
5	107-8536	2	Cover-Belt
7	99-3058	2	Washer
8	107-8516-01	1	Plate-Idler
9	107-1684	3	Pulley
10	106-3214	1	Mount-Pulley
11	1-633109	2	Idler-Flat
12	1-603496	1	Bushing-Idler
13	107-8541-01	1	Baffle-Discharge
14	98-7913	1	Tube-Spacer
15	108-2187-01	1	Baffle ASM
16	3231-31	1	Screw-CARR
17	3290-357	32	Nut-HHF, Whiz
18	323-9	1	Screw-HH
19	3231-4	2	Screw-CARR
20	105-7788	2	Spacer
21	323-28	1	Screw-HH
22	3296-39	4	Nut-Lock, NI
23	32144-70	3	Screw-HWHTF
24	3256-24	4	Washer-Flat
25	92-1624	32	Screw

Ref	Part No.	Qty.	Description
26	108-4121-01	2	Bracket-Cover
27	322-50	1	Screw-HH
28	105-4622	1	Spacer
29	108-4052	1	Spring-Torsion
30	3296-29	1	Nut-Lock, NI
31	107-3192-03	3	Blade-Rotary, 16.5 Inch (High Flow)
32	3231-1	7	Screw-CARR
33	323-23	1	Screw-HH
34	106-7369	1	Belt-V
35	106-6777	2	Handle-Latch, Swell
36	106-6778	2	Bushing-Latch, Swell
37	107-3166-01	1	Skid
38	1-804254	2	Nut
39	108-2228-01	1	Bracket-Cover
41	1-603299	3	Roller-Scalp, Anti
42	98-7912	1	Tube-Spacer
43	98-5967	1	Spacer-Wheel
44	103-0865	3	Washer-Blade Bolt, Heavy
45	103-0862	3	Screw-Cap
47		1	Spring Idler ASM
99	107-3194-03	3	Blade-Rotary, 16.5 Inch (Med Flow)
99	107-3195-03	3	Blade-Rotary, 16.5 Inch (Atomic)

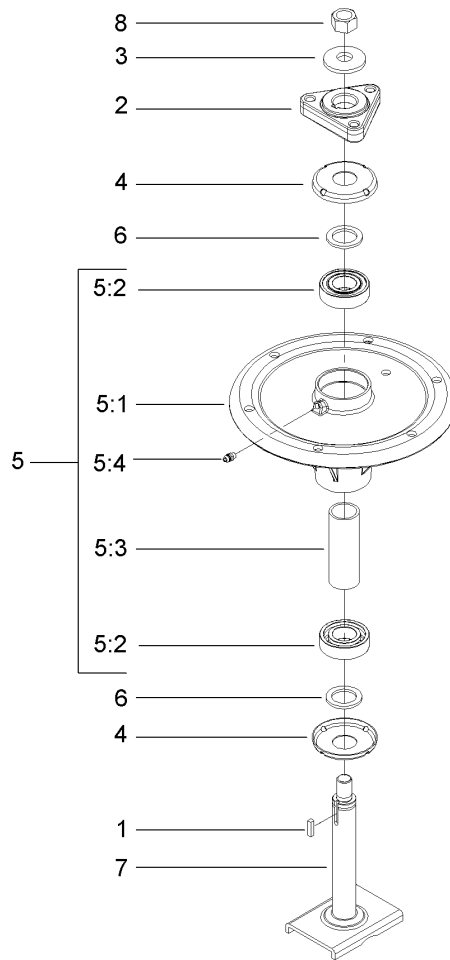

Spindle Assembly No. 107-8504

Ref	Part No.	Qty.	Description
1	10-8040	1	Key-Square
2	106-3277	1	Hub-Pulley
3	103-0865	1	Washer-Blade Bolt, Heavy
4	106-3204	2	Shield-Bearing
5		1	Spindle Bearing ASM
5:1	106-3211	1	Housing-Spindle
5:2	113514	2	Bearing-Ball
5:3	107-8502	1	Spacer-Bearing
5:4	302-5	1	Fitting-Grease
6	3-8514	2	Washer-Thrust
7	107-8501	1	Spindle ASM
8	3219-6	1	Nut-Hex

--	--	--	--

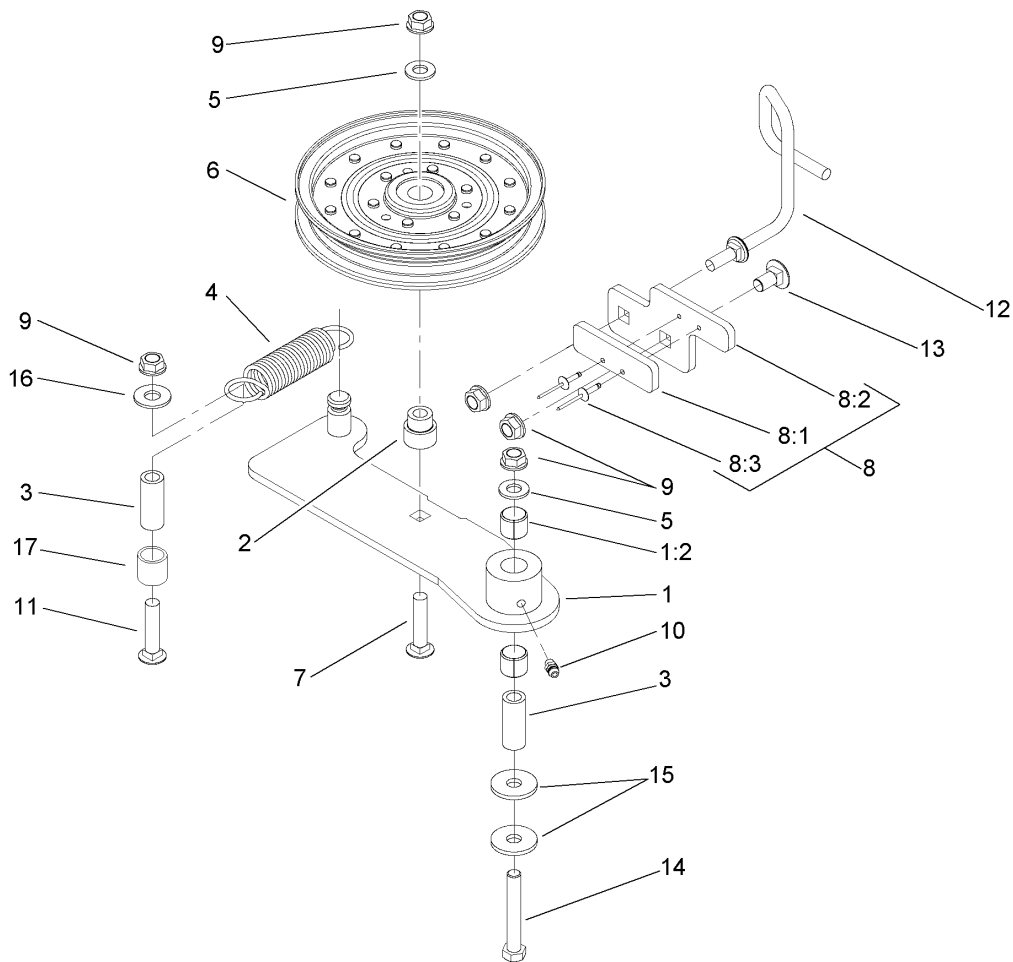

Idler Assembly

Ref	Part No.	Qty.	Description
1	108-4062	1	Idler Arm ASM
1:2	103-4681	2	Sleeve-Bearing
2	1-603496	1	Bushing-Idler
3	1-603044	2	Bushing
4	108-4056	1	Spring-Extension
5	3256-24	2	Washer-Flat
6	1-633109	1	Idler-Flat
7	3231-6	1	Screw-CARR
8		1	Stop Pad ASM
8:1	106-3229	1	Pad-Bumper
8:2	107-1697-01	1	Plate-Stop
8:3	3269-24	2	Rivet
9	3290-357	5	Nut-HHF, Whiz
10	302-5	1	Fitting-Grease
11	3231-31	1	Screw-CARR
12	108-4072	1	Guide-Belt
13	3231-1	1	Screw-CARR
14	323-12	1	Screw-HH
15	2844	2	Washer
16	3256-4	1	Washer-Flat
17	108-4063	1	Spacer-Rubber

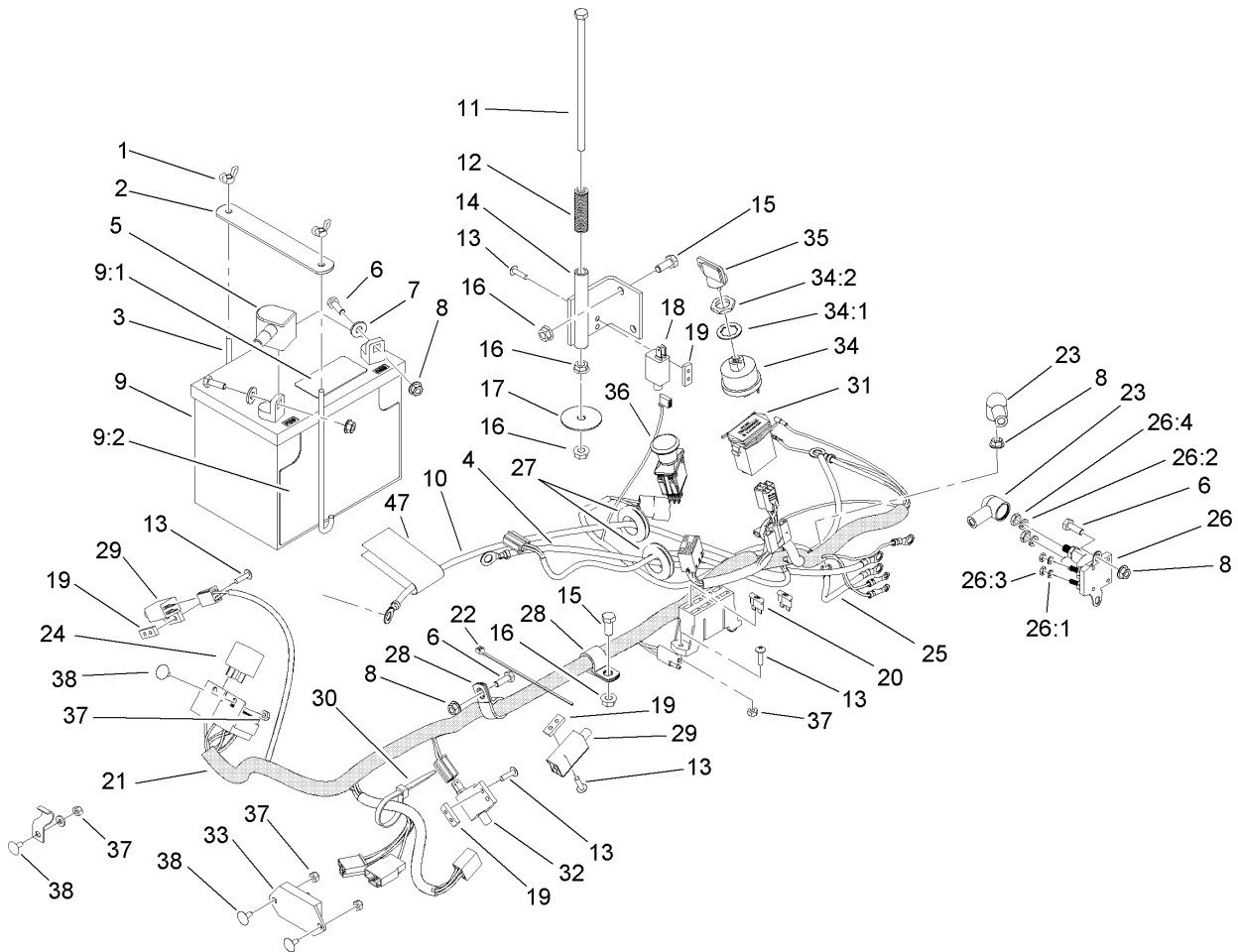

Electrical Assembly

Ref	Part No.	Qty.	Description
1	1-543792	2	Wingnut
2	107-9277-03	1	Strap-Holddown, Battery
3	1-633651	2	Bolt-Holddown
4	103-0705	1	Cable-Ground, Negative
5	1-543391	1	Insulator-Battery
6	321-4	6	Screw-HH
7	3256-2	2	Washer-Flat
8	32128-33	6	Nut-HF
9	105-1692	1	Battery
9:1	104-4163	1	Decal-Battery
9:2	104-4164	1	Decal-Battery
10	103-0707	1	Cable-Battery, Positive
11	1-800282	1	Screw-HH
12	1-523415	1	Spring-Switch, Seat
13	1-803075	10	Screw-Head, Truss
14	1-652072-03	1	Bracket-Switch, Seat
15	322-3	3	Screw-HH
16	32128-20	5	Nut-HF
17	1-653036	1	Washer
18	1-513152	1	Switch-Closed, Normally
19	1-633181	4	Plate-Tapped
20	1-816001	2	Fuse-Blade Type, 20 Amp
21	110-0318	1	Harness-Electrical
22	1-303287	4	Tie-Plastic

Ref	Part No.	Qty.	Description
23	1-543393	1	Insulator-Solenoid
24	1-643275	2	Relay
25	1-633306	1	Cable-Starter, Positive
26	1-513075	1	Switch-Solenoid
26:1	3253-17	2	Washer-Lock
26:2	3253-4	2	Washer-Lock
26:3	3219-14	2	Nut-Hex
26:4	3220-2	2	Nut-Jam
27	1-543286	2	Grommet
28	1-633396	2	Clip-Loom
29	1-513051	2	Switch-Open, Normally
30	1-303335	4	Tie-Plastic
31	1-513374	1	Meter-Hour
32	1-633111	1	Switch
33	100-6186	1	Module-Delay, Seat
34	104-2541	1	Switch-Key
34:1	218-461	1	Nut-HH
34:2	3254-5	1	Washer-Tooth
35	63-8360	2	Key-Ignition
36	103-5221	1	Switch-PTO
37	3296-2	6	Nut-Lock
38	1-807513	4	Bolt-CARR
47	107-9309	1	Decal-Instructions, Charging

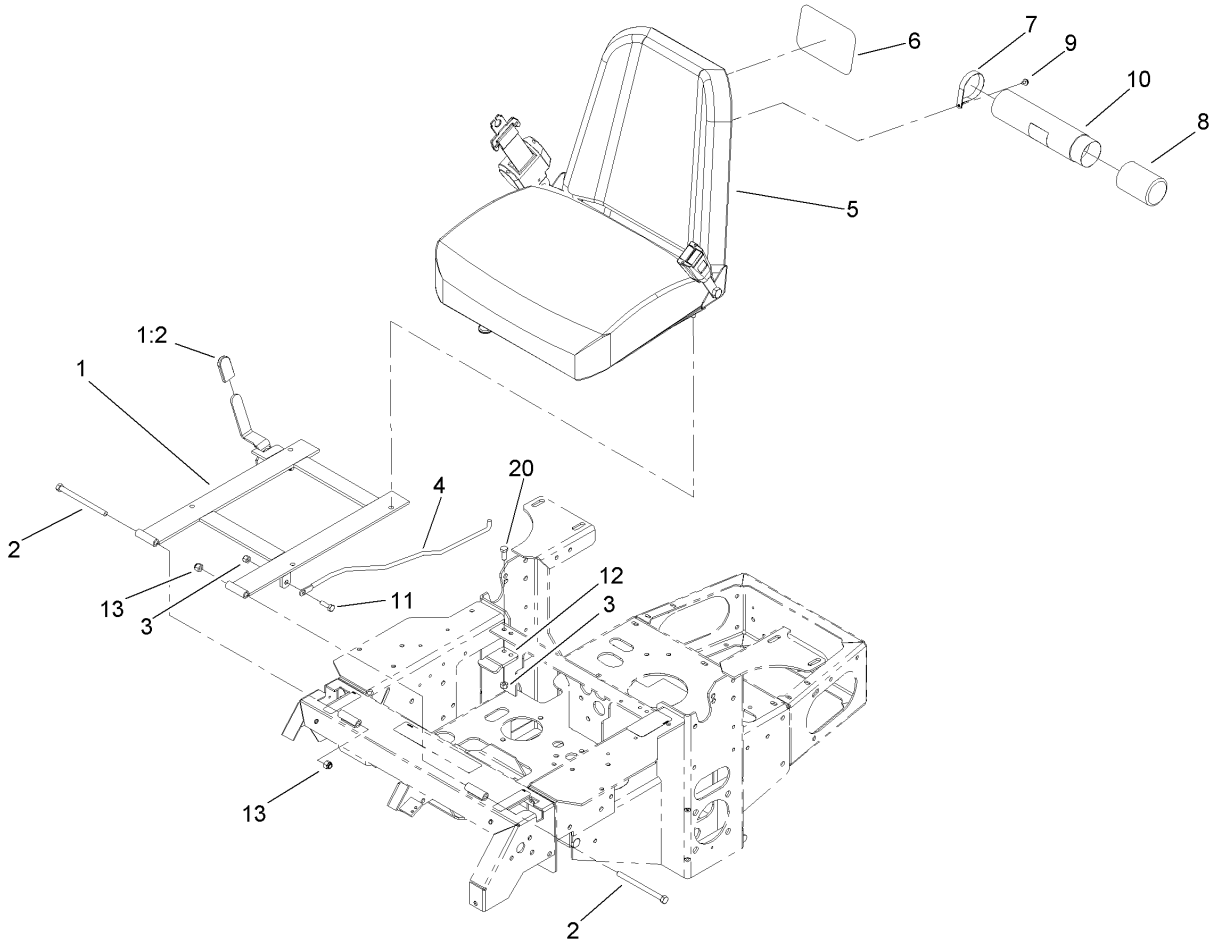

Seat and Bracket Assembly

Ref	Part No.	Qty.	Description				
1	110-5850	1	Seat Frame And Latch ASM				
1:2	103-4434	1	Grip-Lever				
2	323-39	2	Screw-HH				
3	3296-29	3	Nut-Lock, NI				
4	103-1731	1	Rod-Retainer, Seat				
5	110-5738	1	Seat ASM				
6	99-4693	1	Decal				
7	2412-120	2	R-Clamp				
8	104-7048	1	Cap-Housing				
9	32104-76	2	Screw				
10	104-7050	1	Housing-Manual				
11	322-5	1	Screw-HH				
12	103-5961	1	Catch-Latch, Seat				
13	3296-39	2	Nut-Lock, NI				
20	322-4	2	Screw-HH				

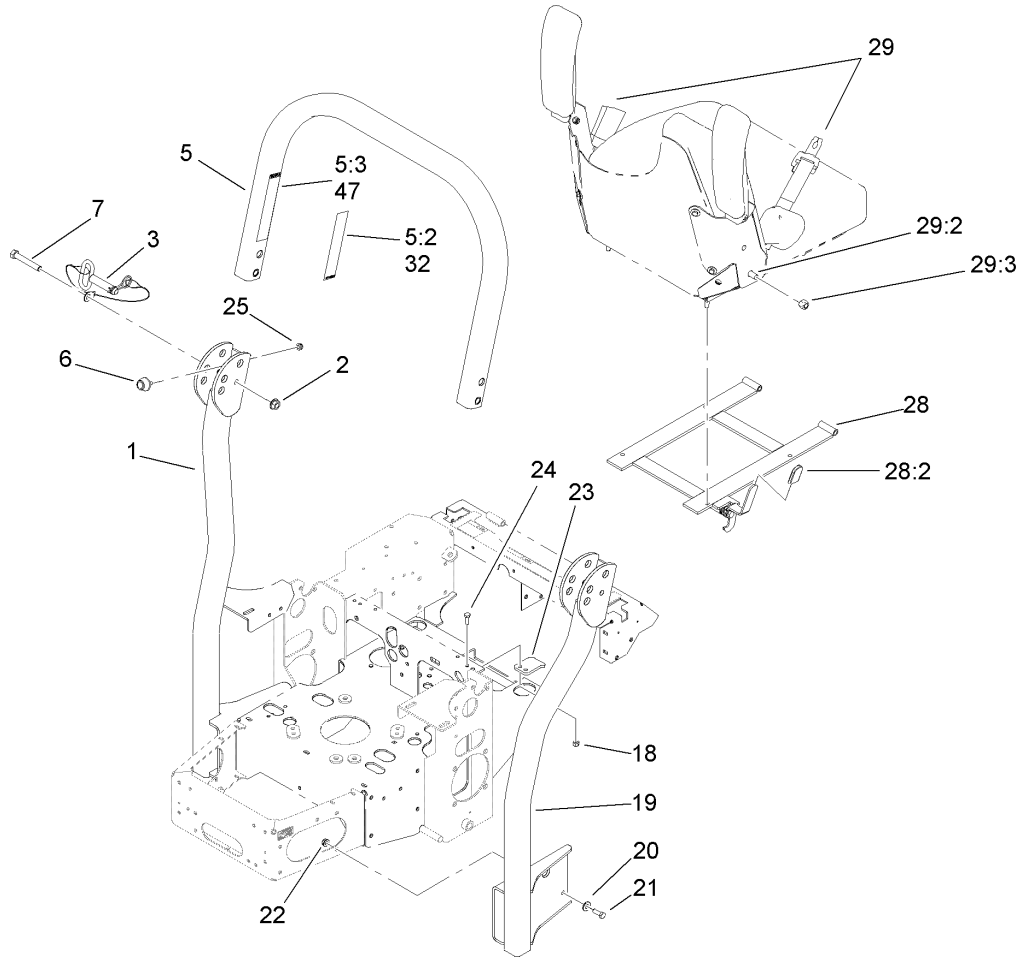

Roll-Over Protection System Assembly No. 107-8093

Ref	Part No.	Qty.	Description				
②1		1	LH Tube Support ASM				
2	32128-23	2	Nut-HF				
3	103-4553	2	ROPS Fold Pin ASM				
②5		1	Upper Tube ASM				
5:2	107-2100	1	Decal				
5:3	107-2102	1	Decal-Warning, Folding ROPS				
6	109-2365	2	Bumper-Rubber (W/Stud)				
7	325-13	2	Screw-HH				
18	3296-29	2	Nut-Lock, NI				
②19		1	RH Tube Support ASM				
20	98-5975	8	Washer-Belleville				
21	323-6	8	Screw-HH				
22	3290-357	8	Nut-HHF, Whiz				
23	107-3059	1	Catch-Latch, Seat				
24	322-4	2	Screw-HH				
25	3296-73	2	Nut-Lock, NI				
28	110-5850	1	Seat Frame And Latch ASM				
28:2	103-4434	1	Grip-Lever				
29	110-0883	1	Retractable Seatbelt Kit				
29:2	3212-4	2	Screw-HH				
29:3	3296-7	2	Nut-Lock				
32	107-3069	1	Decal-Warning, Folding ROPS (Ce)				
47	107-2102	1	Decal-Warning, Folding ROPS				

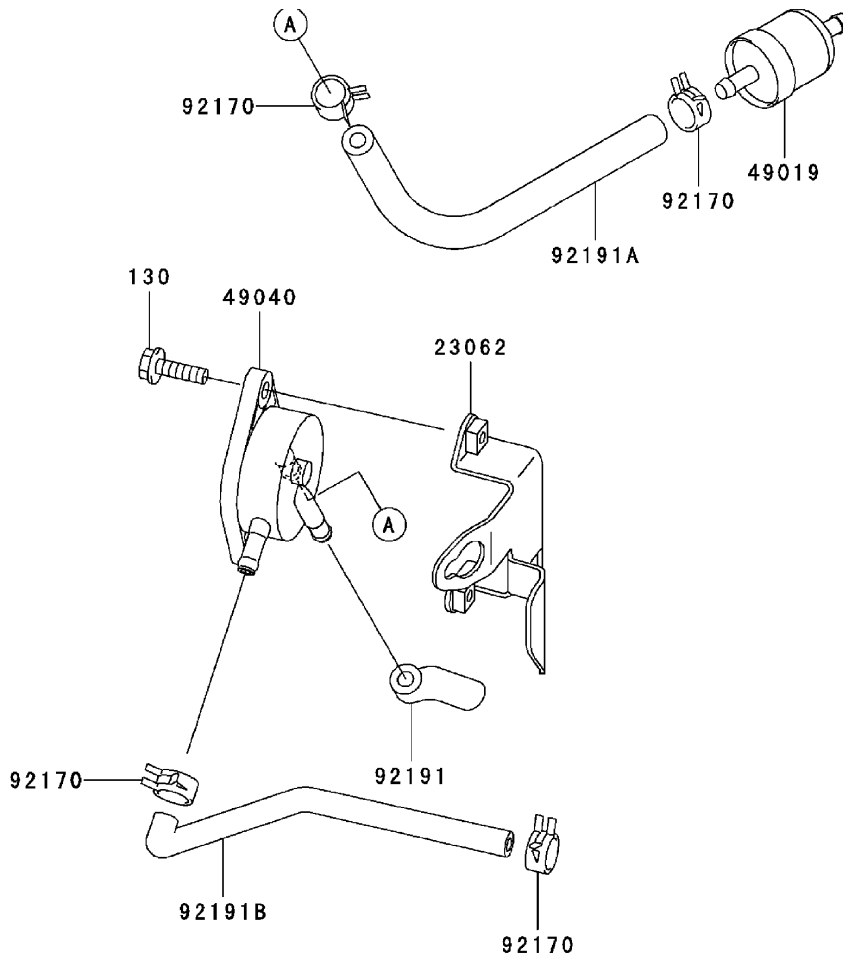

Fuel Tank / Fuel Valve Assembly Kawasaki FH580V AS30

Ref	Part No.	Qty.	Description
④23062	23062-7004-9H	1	Bracket
④49019	49019-7001	1	Filter-Fuel
④49040	49040-7001	1	Pump-Fuel
④92170	92170-2088	4	Clamp
④92191	92191-7002	1	Tube
④92191A	92191-7003	1	Tube (6.35X12.7X160)
④92191B	92191-7004	1	Tube
④130	130B0620	2	Bolt-Flanged (6X20)

Cylinder / Crankcase Assembly Kawasaki FH580V AS30

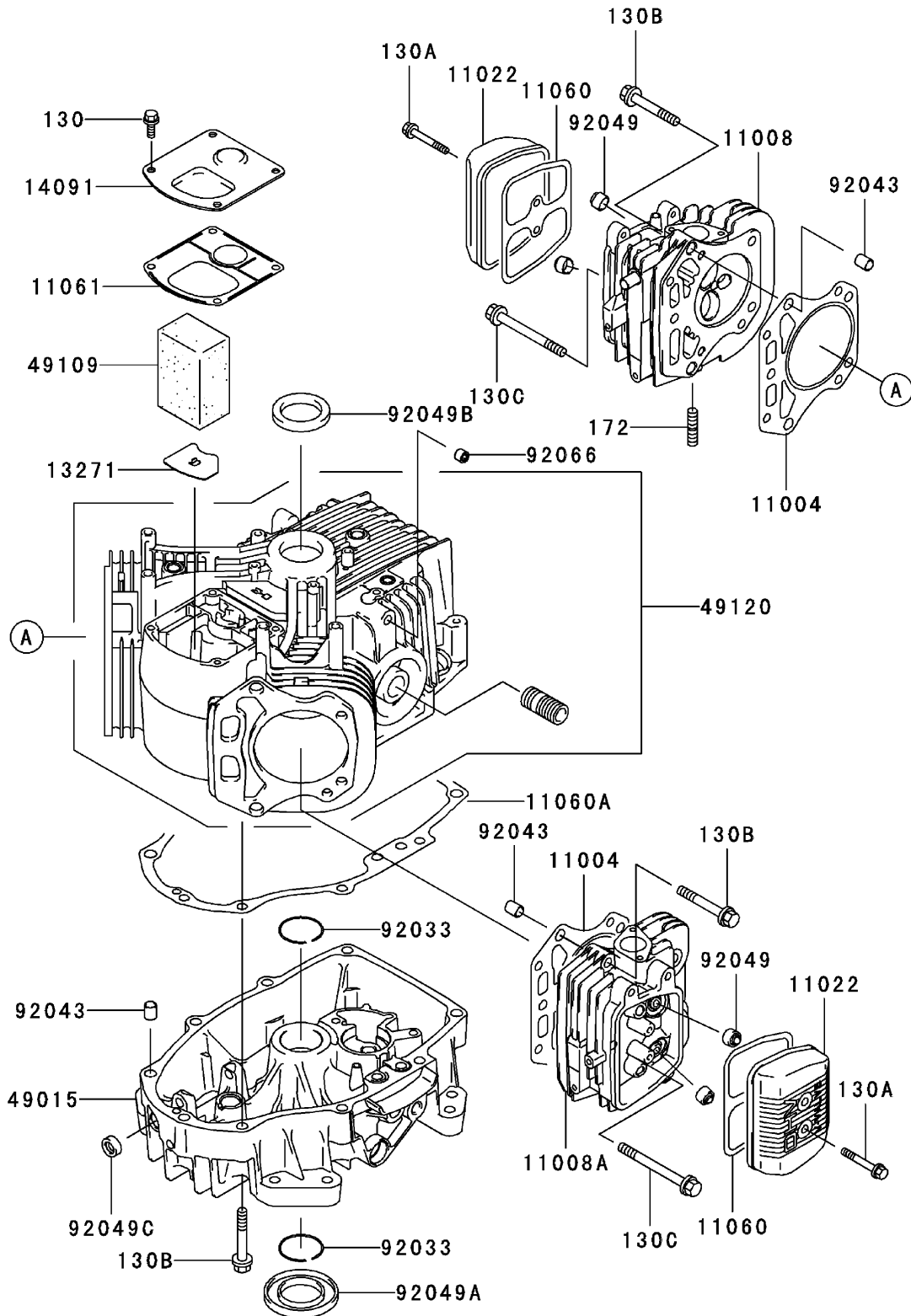

Cylinder / Crankcase Assembly Kawasaki FH580V AS30

Ref	Part No.	Qty.	Description				
④11004	11004-7016	2	Gasket-Head				
④11008	11008-6043	1	Head-Cylinder, No. 1				
④11008A	11008-7020	1	Head-Cylinder, No. 2				
④11022	11022-7003	2	Case-Rocker				
④11060	11060-7001	2	Gasket-Case, Rocker				
④11060A	11060-7008	1	Gasket-Cover, Crankcase				
④11061	11061-7001	1	Gasket-Breather				
④13271	13271-7016	1	Plate				
④14091	14091-7006	1	Cover				
④49015	49015-6253	1	Cover-Crankcase				
④49109	49109-7002	1	Element-Breather				
④49120	49120-7023	1	Crankcase				
④92033	92033-7003	2	Ring-Snap				
④92043	92043-7001	6	Pin				
④92049	92049-7001	4	Seal-Oil, R V C2 (6X11X10.2)				
④92049A	92049-7015	1	Seal-Oil, S D (35X62X8 L HSH)				
④92049B	92049-7016	1	Seal-Oil, S D (35X48X8 R HSH)				
④92049C	92049-7019	1	Seal-Oil, S O (8X14X5 HSH)				
④92066	92066-7002	1	Plug				
④130	130B0612	4	Bolt-Flanged (6X12)				
④130A	130B0640	4	Bolt-Flanged (6X40)				
④130B	130T0850	17	Bolt-Flanged (8X50)				
④130C	130T0875	2	Bolt-Flanged (8X75)				
④172	172G0818	4	Bolt-Stud (8X18)				

Piston / Crankshaft Assembly Kawasaki FH580V AS30

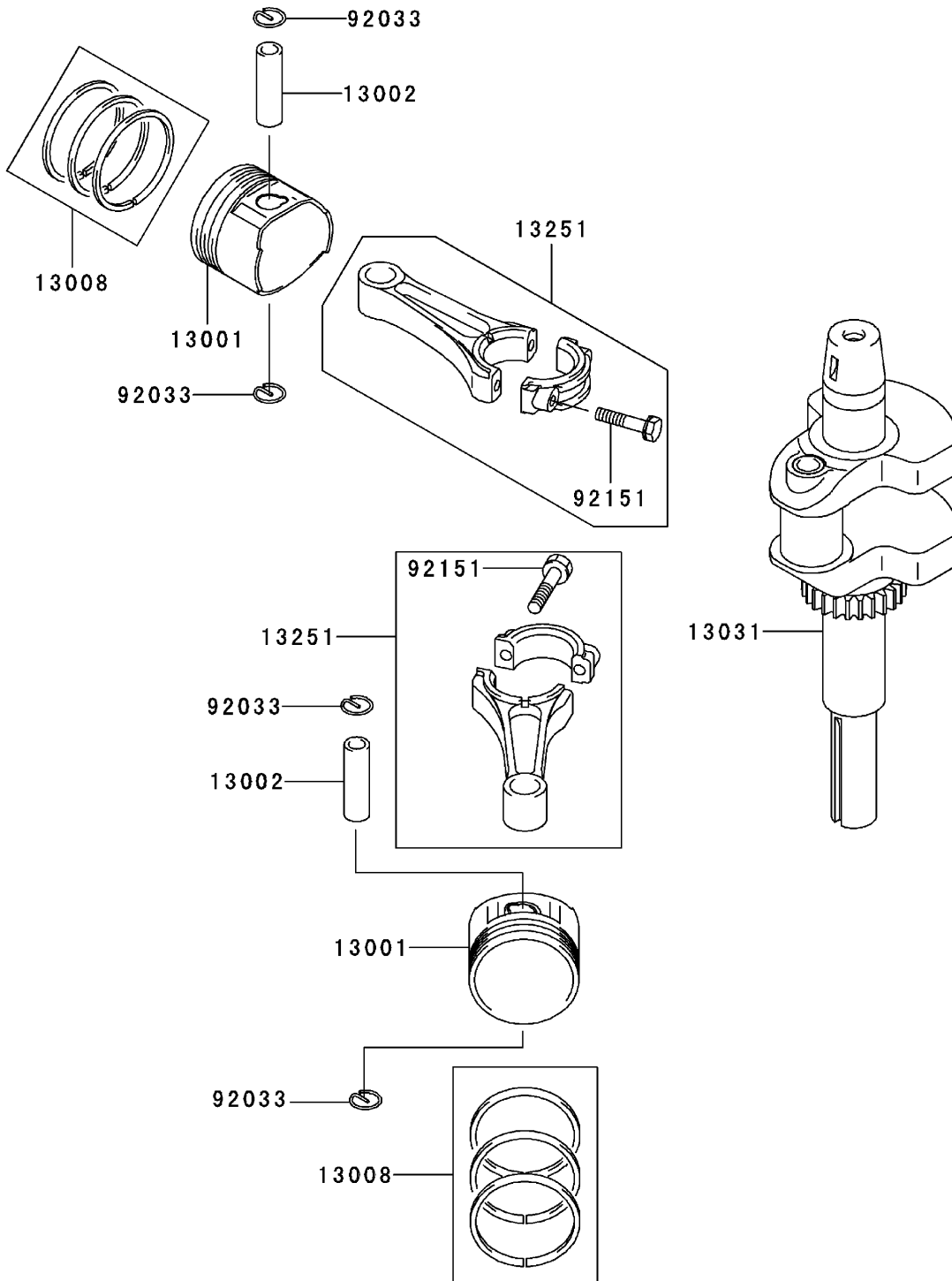

Piston / Crankshaft Assembly Kawasaki FH580V AS30

Ref	Part No.	Qty.	Description				
④13001	13001-7010	2	Piston-Engine				
④13002	13002-7001	2	Pin-Piston				
④13008	13008-6060	2	Ring Set-Piston				
④13031	13031-7036	1	Crankshaft				
④13251	13251-7010	2	Connecting Rod ASM				
④92033	92033-7005	4	Ring-Snap				
④92151	92151-7017	4	Bolt (6X35)				

Valve / Camshaft Assembly Kawasaki FH580V AS30

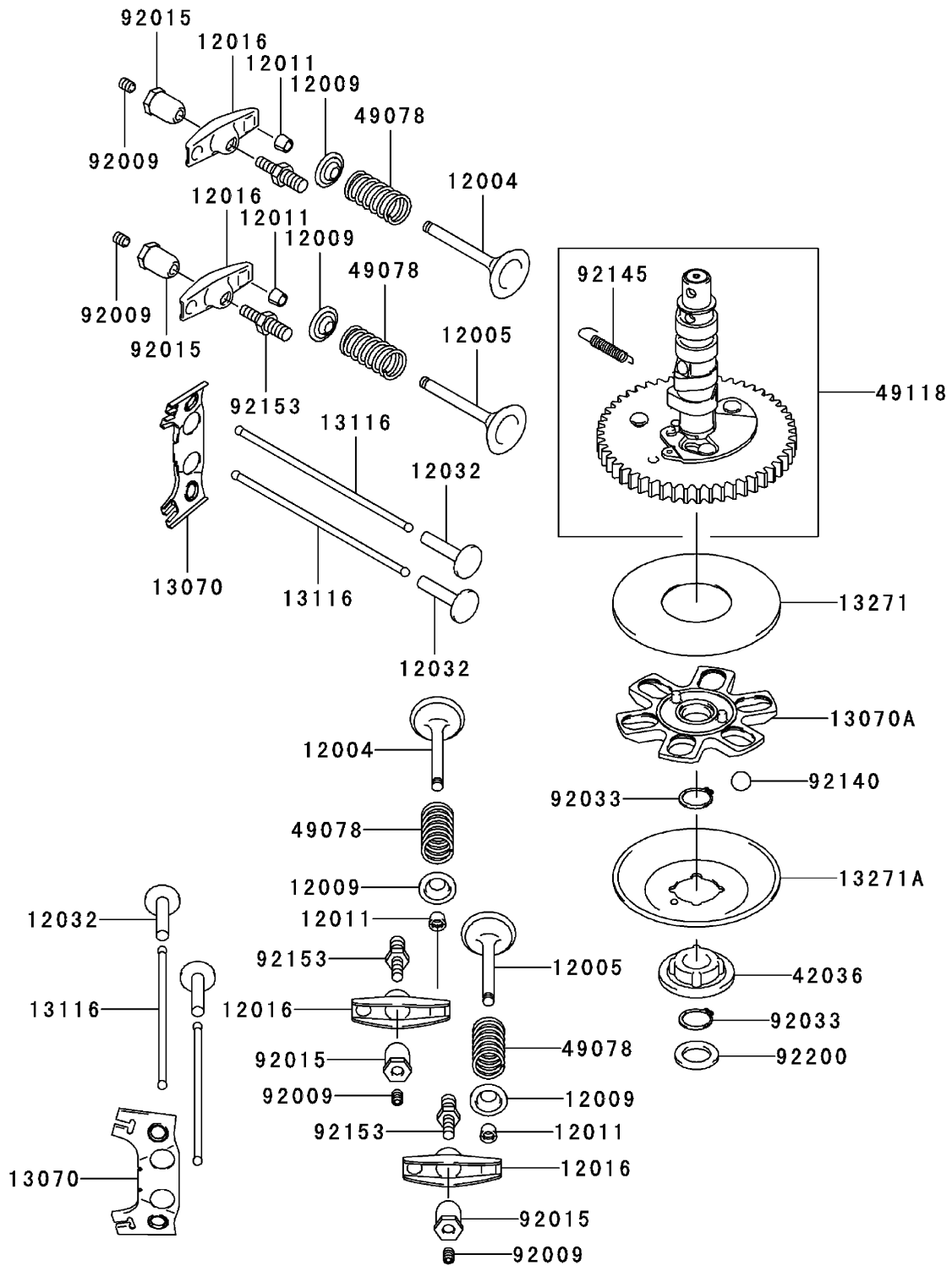

Valve / Camshaft Assembly Kawasaki FH580V AS30

Ref	Part No.	Qty.	Description				
④12004	12004-7003	2	Valve-Intake				
④12005	12005-7003	2	Valve-Exhaust				
④12009	12009-7001	4	Retainer-Spring, Valve				
④12011	12011-2056	8	Collet				
④12016	12016-7001	4	Arm-Rocker				
④12032	12032-7001	4	Tappet				
④13070	13070-7001	2	Guide				
④13070A	13070-7004	1	Guide				
④13116	13116-2057	4	Rod-Push				
④13271	13271-7007	1	Plate				
④13271A	13271-7021	1	Plate-Governor				
④42036	42036-7009	1	Sleeve				
④49078	49078-7001	4	Spring-Valve, Engine				
④49118	49118-7004	1	Camshaft				
④92009	92009-2341	4	Screw				
④92015	92015-2253	4	Nut				
④92033	92033-7001	2	Ring-Snap				
④92140	92140-7002	6	Ball				
④92145	92145-7001	1	Spring				
④92153	92153-7019	4	Bolt				
④92200	92200-7001	1	Washer				

Lubrication Equipment Assembly Kawasaki FH580V AS30

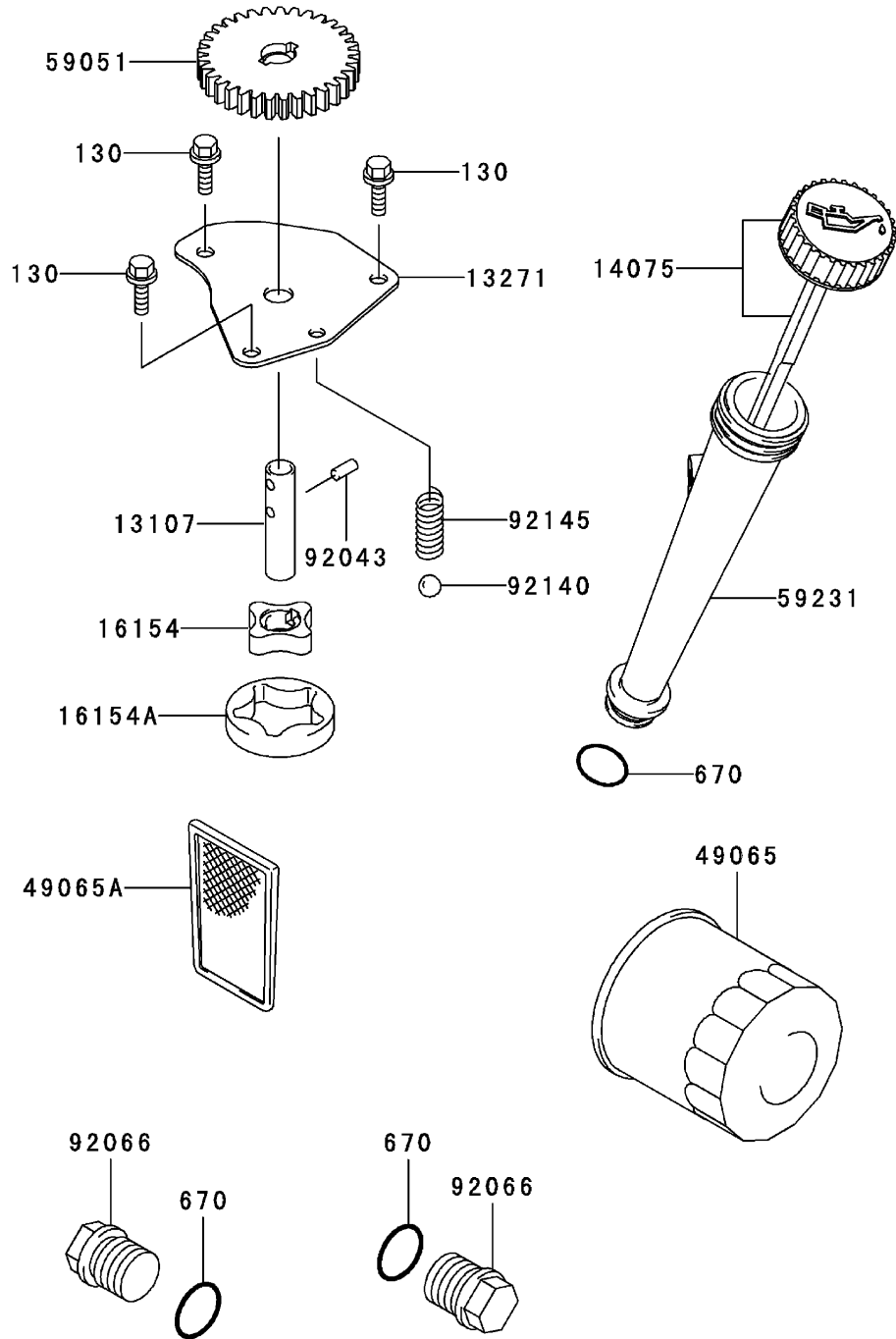

Lubrication Equipment Assembly Kawasaki FH580V AS30

Ref	Part No.	Qty.	Description				
④13107	13107-7009	1	Shaft				
④13271	13271-7017	1	Plate				
④14075	14075-7009	1	Cap ASM				
④16154	16154-2053	1	Rotor-Pump (In)				
④16154A	16154-2054	1	Rotor-Pump (Out)				
④49065	49065-2078	1	Filter-Oil				
④49065A	49065-7004	1	Filter-Oil				
④59051	59051-7011	1	Gear-Spur				
④59231	59231-7005	1	Filler				
④92043	92043-7003	2	Pin				
④92066	92066-7003	2	Plug				
④92140	92140-7003	1	Ball				
④92145	92145-7002	1	Spring				
④130	130B0612	3	Bolt-Flanged (6X12)				
④670	670D2016	3	O-Ring (16Mm)				

Cooling Equipment Assembly Kawasaki FH580V AS30

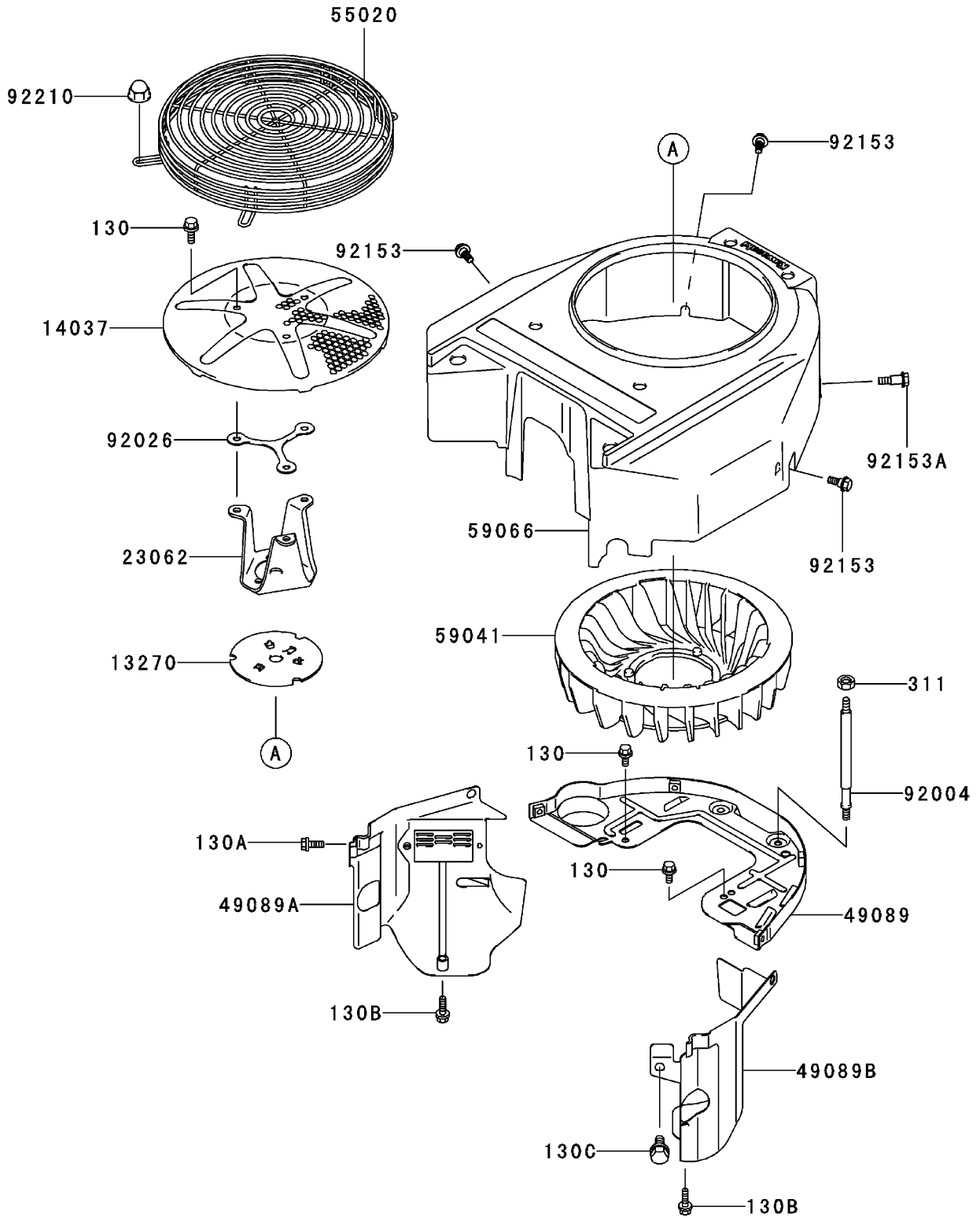

Cooling Equipment Assembly Kawasaki FH580V AS30

Ref	Part No.	Qty.	Description				
④13270	13270-7007	1	Plate				
④14037	14037-7020-9H	1	Screen				
④23062	23062-7010	1	Bracket				
④49089	49089-7032	1	Shroud-Engine				
④49089A	49089-7042	1	Shroud-Engine				
④49089B	49089-7043	1	Shroud-Engine				
④55020	55020-7004	1	Guard				
④59041	59041-7010	1	Fan				
④59066	59066-7024	1	Housing-Fan				
④92004	92004-7006	2	Stud				
④92026	92026-7007	1	Spacer				
④92153	92153-7007	3	Bolt				
④92153A	92153-7008	1	Bolt				
④92210	92210-0003	4	Nut				
④130	130B0612	5	Bolt-Flanged (6X12)				
④130A	130B0616	2	Bolt-Flanged (6X16)				
④130B	130B0625	2	Bolt-Flanged (6X25)				
④130C	130B0816	1	Bolt-Flanged (8X16)				
④311	311B0600	2	Nut-Hex (6Mm)				

Electric Equipment Assembly Kawasaki FH580V AS30

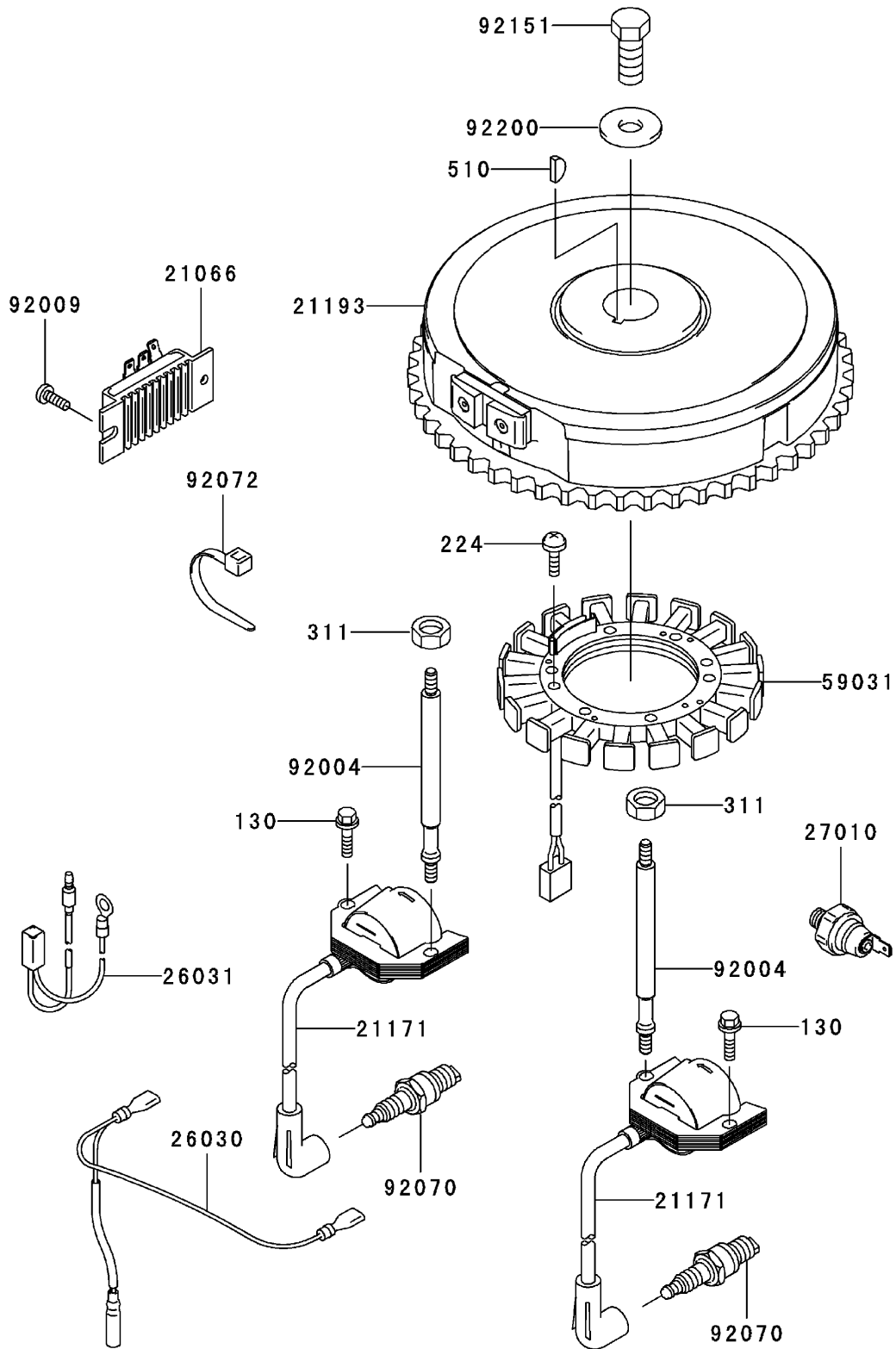

Electric Equipment Assembly Kawasaki FH580V AS30

Ref	Part No.	Qty.	Description				
④21066	21066-7011	1	Regulator-Voltage				
④21171	21171-7013	2	Ignition Coil ASM				
④21193	21193-7007	1	Flywheel ASM				
④26030	26030-7001	1	Harness				
④26031	26031-7002	1	Harness				
④27010	27010-7001	1	Switch				
④59031	59031-7001	1	Coil-Charging				
④92004	92004-7009	2	Stud				
④92009	92009-2308	1	Screw				
④92070	92070-7003	2	Plug-Spark (R C J 8 Y, Solid)				
④92072	92072-7003	2	Band				
④92151	92151-2097	1	Bolt (12X30)				
④92200	92200-7002	1	Washer				
④130	130B0620	2	Bolt-Flanged (6X20)				
④224	224B0520	4	Screw-Pan (5X20)				
④311	311B0600	2	Nut-Hex (6Mm)				
④510	510A5100	1	Key-Woodruff				

Control Equipment Assembly Kawasaki FH580V AS30

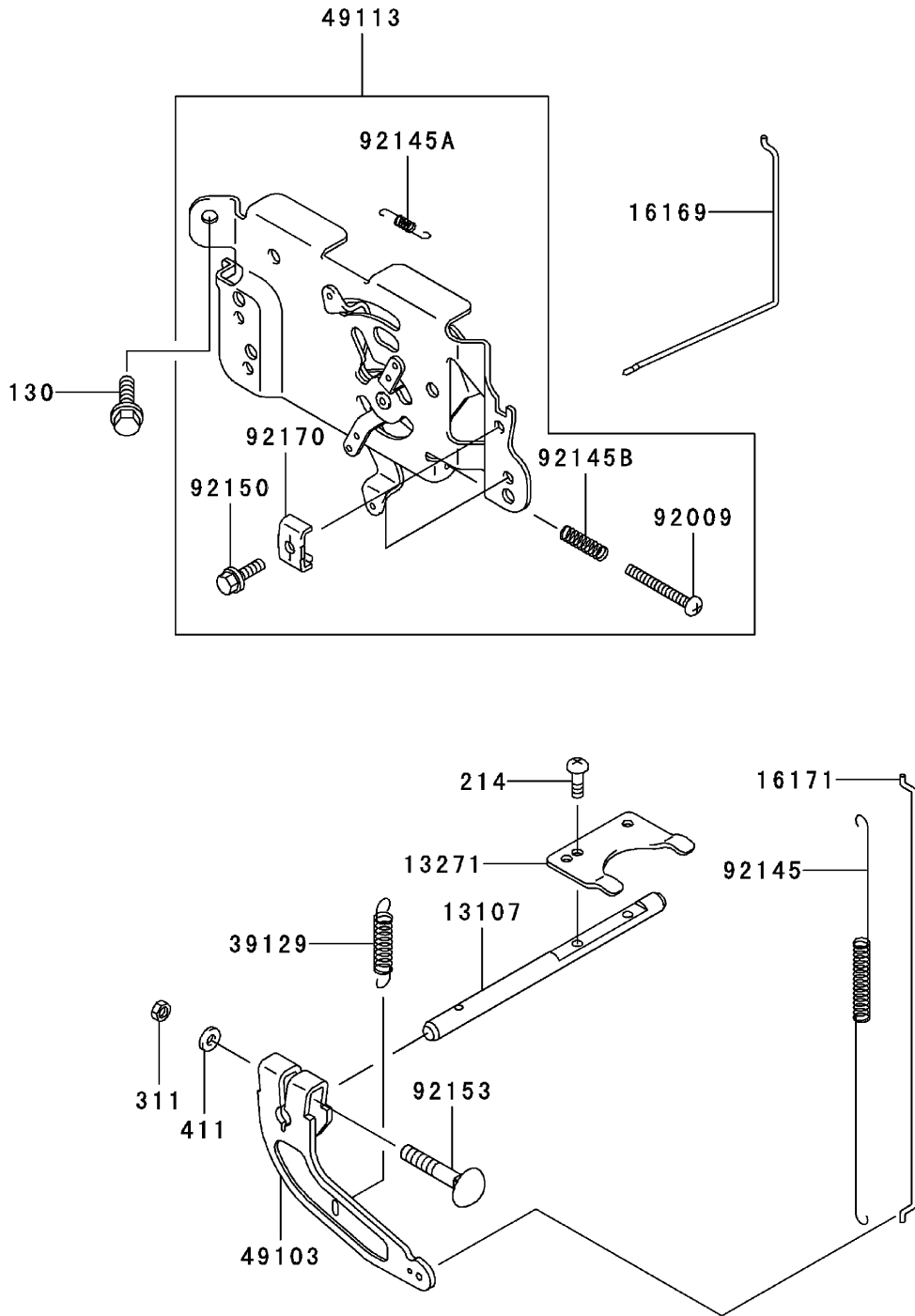

Control Equipment Assembly Kawasaki FH580V AS30

Ref	Part No.	Qty.	Description				
④13107	13107-7010	1	Shaft				
④13271	13271-7018	1	Plate				
④16169	16169-7010	1	Link-Choke				
④16171	16171-7001	1	Link				
④39129	39129-7003	1	Spring-Governor				
④49103	49103-7004	1	Arm-Governor				
④49113	49113-7011	1	Panel-Control				
④92009	92009-7007	1	Screw (4X35)				
④92145	92145-7003	1	Spring				
④92145A	92145-7004	1	Spring				
④92145B	92145-7005	1	Spring				
④92150	92150-2182	2	Bolt (5X18)				
④92153	92153-7033	1	Bolt (6X35)				
④92170	92170-7001	2	Clamp				
④130	130B0612	2	Bolt-Flanged (6X12)				
④214	214B0408	2	Screw-Pan (4X8)				
④311	311B0600	1	Nut-Hex (6Mm)				
④411	411B0600	1	Washer-Plain (6Mm)				

Carburetor Assembly Kawasaki FH580V AS30

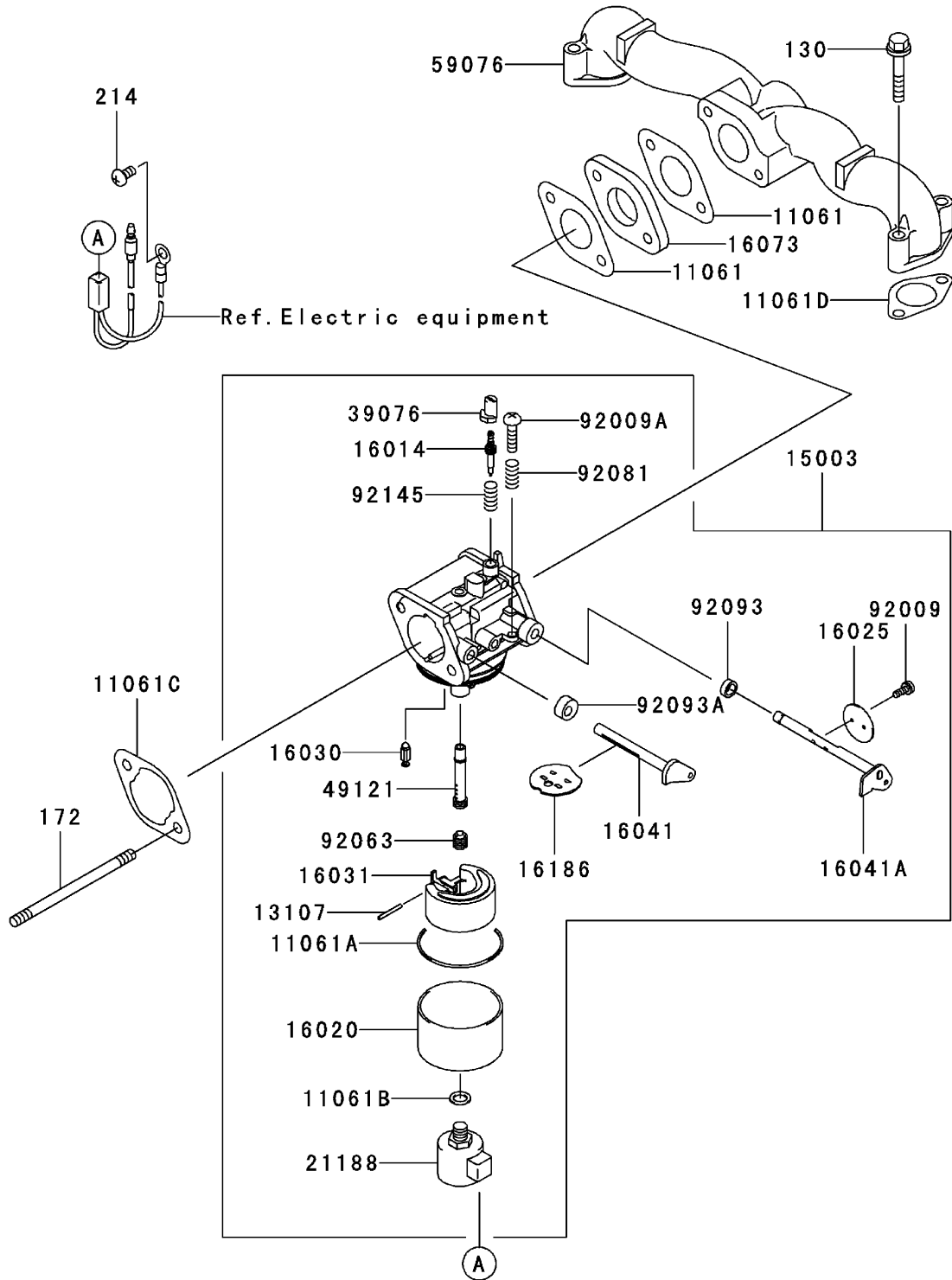

Carburetor Assembly Kawasaki FH580V AS30

Ref	Part No.	Qty.	Description				
④11061	11061-7004	2	Gasket-Insulator				
④11061A	11061-7009	1	Gasket-Chamber				
④11061B	11061-7010	1	Gasket-Screw				
④11061C	11061-7018	1	Gasket-Cleaner, Air				
④11061D	11061-7019	2	Gasket				
④13107	13107-7018	1	Shaft				
④15003	15003-7100	1	Carburetor ASM				
④16014	16014-7007	1	Screw-Air, Pilot				
④16020	16020-7003	1	Chamber-Float				
④16025	16025-7006	1	Valve-Throttle				
④16030	16030-7003	1	Valve-Float				
④16031	16031-7002	1	Float				
④16041	16041-7016	1	Shaft-Choke, Carburetor				
④16041A	16041-7018	1	Shaft-Throttle, Carburetor				
④16073	16073-7007	1	Insulator				
④16186	16186-7004	1	Choke Valve ASM				
④21188	21188-7002	1	Solenoid				
④39076	39076-7001	1	Limiter				
④49121	49121-7004	1	Nozzle-Main				
④59076	59076-7001	1	Manifold-Intake				
④92009	92009-2083	2	Screw				
④92009A	92009-2349	1	Screw				
④92063	92063-7062	1	Jet-Main (No. 110)				
④92081	92081-2234	1	Spring				
④92093	92093-2100	1	Seal				
④92093A	92093-7003	1	Seal				
④92145	92145-7015	1	Spring				
④130	130B0635	4	Bolt-Flanged (6X35)				
④172	172G0690	2	Bolt-Stud (6X90)				
④214	214B0510	1	Screw-Pan (5X10)				

Air Filter / Muffler Assembly Kawasaki FH580V AS30

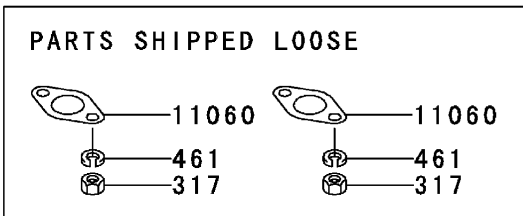
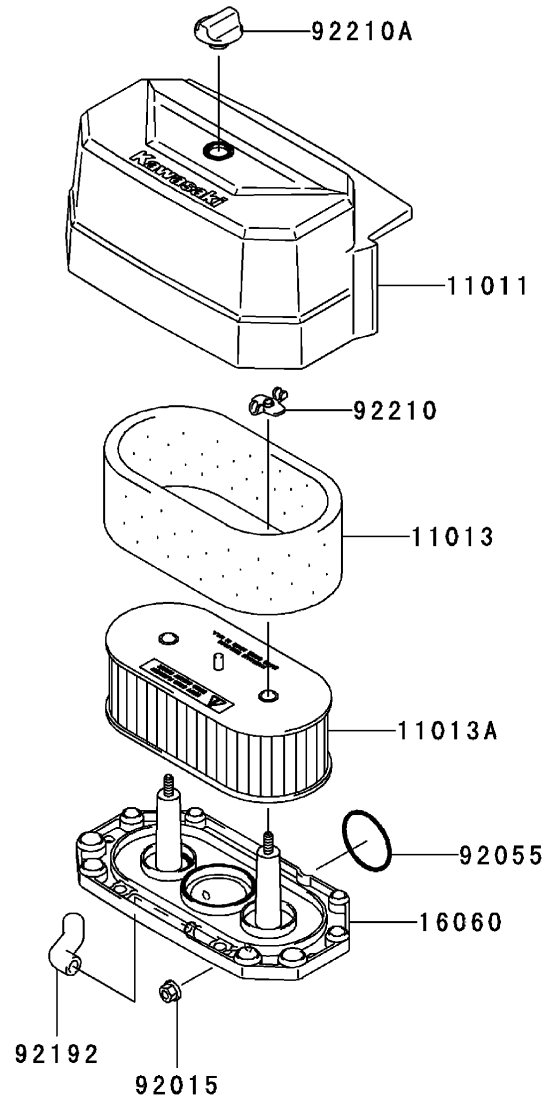

Air Filter / Muffler Assembly Kawasaki FH580V AS30

Ref	Part No.	Qty.	Description				
④11011	11011-7036	1	Case-Airfilter				
④11013	11013-7025	1	Element-Filter, Air				
④11013A	11013-7031	1	Element-Filter, Air				
④11060	11060-7021	2	Gasket-Muffler				
④16060	16060-7016	1	Pipe-Intake				
④92015	92015-1193	2	Nut				
④92055	92055-7015	1	O-Ring				
④92192	92192-7010	1	Tube				
④92210	92210-7004	2	Nut				
④92210A	92210-7019	1	Nut				
④317	317R0800	4	Nut-Hex (8Mm)				
④461	461F0800	4	Washer-Spring (8Mm)				

Starter Assembly Kawasaki FH580V AS30

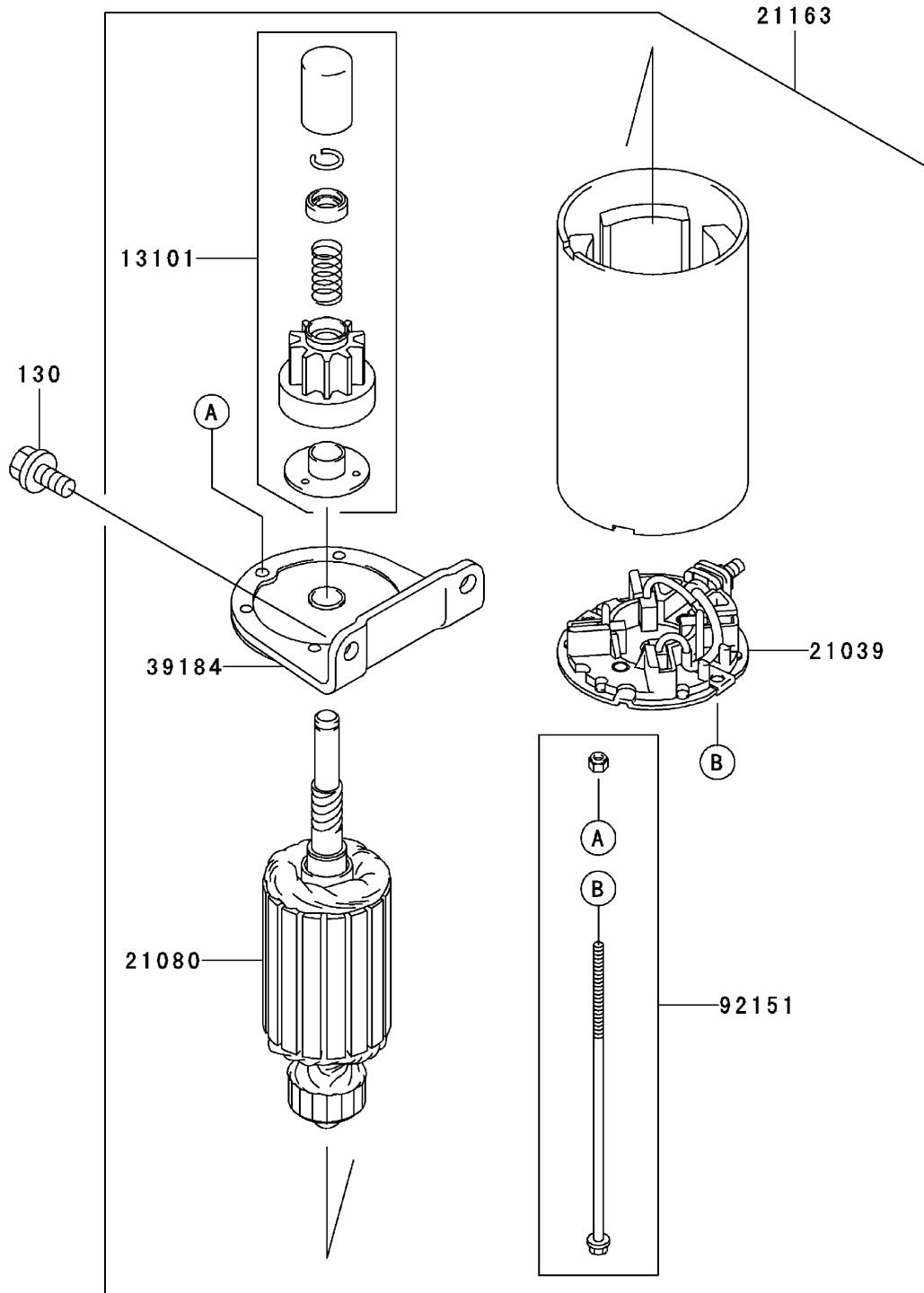

Starter Assembly Kawasaki FH580V AS30

Ref	Part No.	Qty.	Description				
④13101	13101-7003	1	Gear ASM				
④21039	21039-7004	1	Brush				
④21080	21080-7001	1	Armature				
④21163	21163-7010	1	Starter-Electric				
④39184	39184-7004	1	Bracket ASM				
④92151	92151-7013	1	Bolt				
④130	130B0816	2	Bolt-Flanged (8X16)				

56033

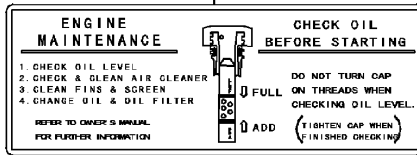

56070



56080



**Label Assembly
Kawasaki FH580V AS30**

Ref	Part No.	Qty.	Description
④56033	56033-7002	1	Label-Manual
④56070	56070-7001	1	Label-Warning
④56080	56080-7022	1	Label-Brand

Attachments and Accessories

For 74418 - Z400 Z Master, With 48in 7-Gauge Side Discharge Mower

Product Name	Model/Part
Striping Kit	106-3370
Deluxe Suspension Seat	107-1891
Suspension Kit for Standard Seat	107-1892
Z Stand Kit	107-8599
Bagging Enhancement Kit	108-4091
Blade-Hi Flow, 16.5 Inch (6 Pack)	110-0414
Blade-Lo Flow, 16.5 Inch (6 Pack)	110-0415
Blade-Recycler, 16.5 Inch (6 Pack)	110-0416
Blade-Atomic, 16.5 Inch (6 Pack)	110-0417
Blade-Mid Flow, 16.5 Inch (6 Pack)	110-0418
16-ounce Tire Sealant	110-8831
32-ounce Tire Sealant	110-8832
1-gallon Tire Sealant	110-8833
5-gallon Tire Sealant	110-8834
1-gallon Tire Sealant Pump	110-8835
5-gallon Tire Sealant Pump	110-8836
Channel Reinforcement Kit	112-8673
Hitch Kit	99-8924

NOTES

NOTES

