



22in Recycler[®] Lawn Mower

Model No. 20094 - 270000001 and up.

Parts Catalog

Ordering Replacement Parts

To order replacement parts, please supply the part number, the quantity, and the description of each part desired.

Understanding Reference Numbers

Each identified part in an illustration has a reference number. The reference number for a part also appears in the parts list, along with other information about the part.

This catalog uses two special reference number formats, one to indicate parts in a service assembly and another to indicate the quantity of a given part in an illustration.

Service Assembly Reference Numbers

Parts in service assemblies have reference numbers in the form a:b. The a represents the reference number of the entire service assembly and the b represents a sequential number unique to each part within the service assembly.

For example, a wheel assembly might be identified by reference number 6, the tire by 6:1, the valve by 6:2, and the wheel by 6:3. When you order the assembly identified by reference number 6, you receive all parts identified by reference numbers 6:1, 6:2, and 6:3. However, you may also order any part individually. Reference numbers of this type appear in illustrations and in part lists.

Reference Numbers Indicating Quantity

In an illustration, if a reference number indicates more than one part, the reference number has the form nX y. The n represents the quantity of the part, the X is the multiplication symbol, and the y represents the reference number.

For example, in an illustration, the reference number 2X 37 means that two of the parts identified by reference number 37 are indicated.

Contents

Description	Page	Description	Page
Deck, Side Chute and Rear Door Assembly 3	Carburetor Assembly No. 640350 Tecumseh LV195EA-362089D 11
Housing Assembly No. 112-8850 4	Engine Assembly No. 1 Tecumseh LV195EA-362089D 12
Rear Axle Assembly 5	Engine Assembly No. 2 Tecumseh LV195EA-362089D 14
Front Axle and Transmission Assembly 6	Recoil Starter Assembly No. 590702 Tecumseh LV195EA-362089D 16
Transmission Assembly No. 106-3955 7	Attachments and Accessories List 17
Engine and Blade Assembly 8		
Handle Assembly 9		
Rear Bag Assembly 10		

Part Description Abbreviations

Part descriptions in this catalog may include the following abbreviations.

AR. as required	HYD. hydraulic
ASM. assembly	LH. left hand
BBC. blade brake clutch	NI. nylon insert
CARR. carriage	NPTF. national pipe thread fine
DEG. degrees	PFH. phillips flat head
EXT. external	PPH. phillips pan head
FH. flat head	PPHTF. phillips pan head thread forming
GA. gauge	PRH. phillips round head
HD. heavy-duty	PTH. phillips truss head
HF. hex flange	PTO. power-take-off
HH. hex head	RH. right hand
HHF. hex head flange	ROPS. roll-over protection system
HHFTF. hex head flange thread forming	SFH. slotted fillister head
HJ. hex jam	SHH. slotted hex head
HLH. hex lag head	SHWH. slotted hex washer head
HOC. height-of-cut	SPH. slotted pan head
HSBH. hex socket button head	SQH. square head
HSFH. hex socket flat head	SRH. slotted round head
HSH. hex socket head	STD. standard
HWH. hex washer head	TAP. self tapping
HWHTF. hex washer head thread forming	TTH. torx truss head

Footnotes

- | | |
|--|----------------------------------|
| ❶ Not illustrated | ❷ Not serviced separately |
| ❸ Obtain from your local Tecumseh dealer | ❹ Included in Repair Kit 632760B |

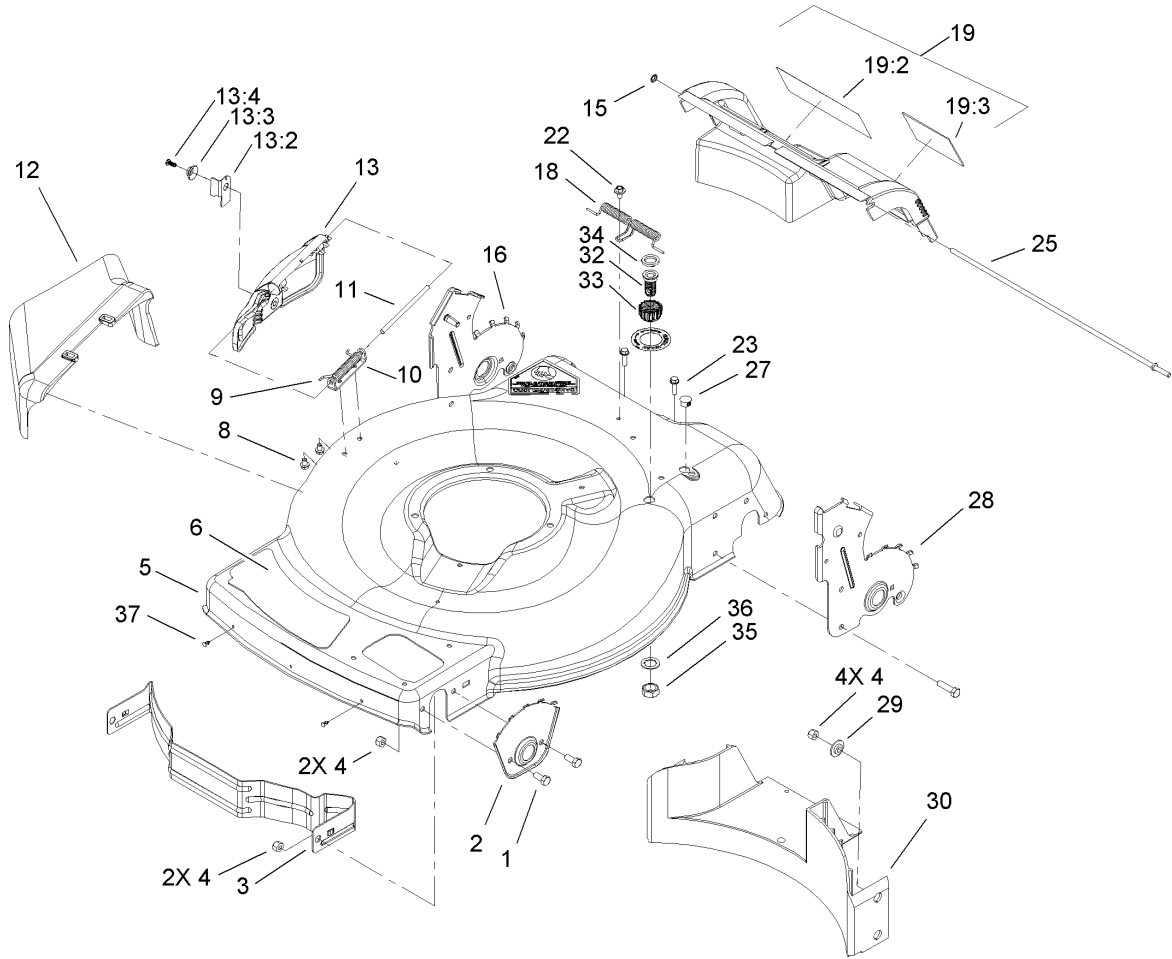

Deck, Side Chute and Rear Door Assembly

Ref	Part No.	Qty.	Description
1	322-3	4	Screw-HH
2	105-1808-03	2	Plate-HOC, Front
3	104-8694-03	1	Baffle-Front
4	3296-29	8	Nut-Lock, NI
5	112-8850	1	Housing ASM
6	114-0322	1	Decal-Deck
8	99-8445	2	Screw-HWH
9	99-5293	1	Spring-Torsion
10	112-6416	1	Bracket-Cover
11	99-5291	1	Rod-Cover
12	105-3028	1	Chute-Discharge, Side
13	106-8376	1	Discharge Door ASM
13:2	107-0795	1	Latch-Door
13:3	107-7456	1	Cap-Door
13:4	107-7461	1	Screw-Plastite
15	32112-6	1	Nut-Push
16	112-6441	1	RH 8 Inch HOC Plate ASM
18	105-3032	1	Spring-Door, Rear
19	112-8865	1	Rear Door ASM (Ce)
19:2	112-8759	1	Decal-Warning, Ce
19:3	104-7908	1	Decal-Warning
22	46-6810	1	Screw And Washer ASM
23	46-8091	2	Screw-HWH
25	105-1827	1	Rod-Pivot, Rear Door

Ref	Part No.	Qty.	Description
27	104-9369	1	Plug-Dome
28	112-6443	1	LH 8 Inch HOC Plate ASM
29	105-3006	4	Washer-Stepped
30	105-3047	1	Baffle-Rear
32	112-6400	1	Port-Washout
33	112-6401	1	Coupling-Hose, Washout Port
34	112-6438	1	Washer-Seal, Washout Port
35	3218-6	1	Nut-Jam
36	3254-5	1	Washer-Tooth
37	112-6436	3	Plug-Arrow

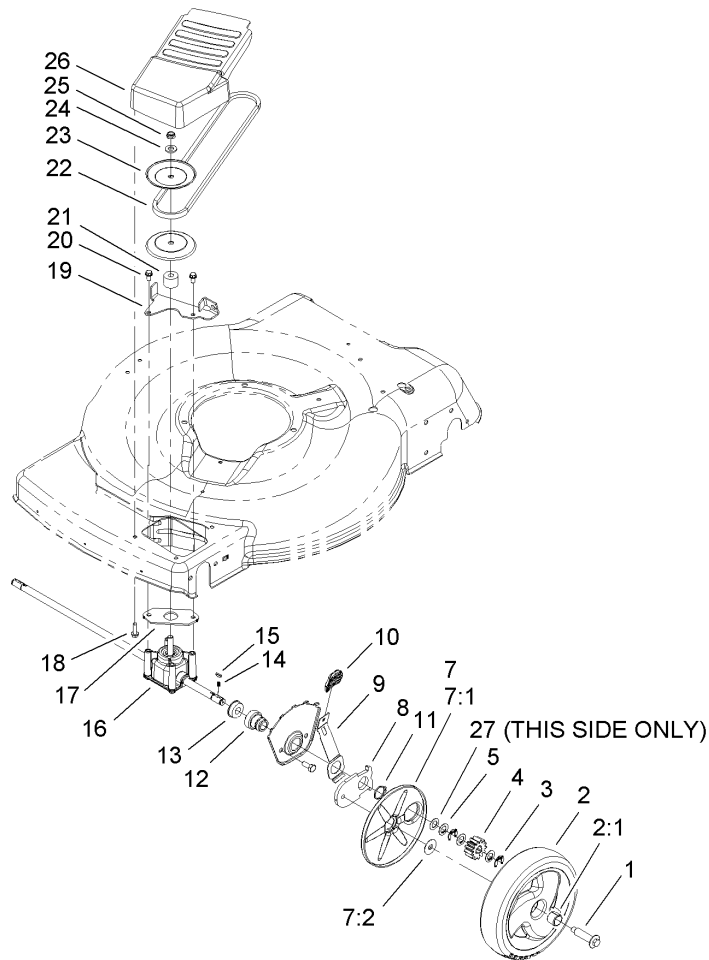

Front Axle and Transmission Assembly

Ref	Part No.	Qty.	Description
1	614650	2	Bolt-Shoulder
2	105-1815	2	Wheel Gear ASM
2:1	27-6250	2	Bushing
3	65-2720	4	Klipring-Locking
4	104-8670	2	Gear-Pinion, 13T
5	105-6840	6	Washer-Thrust
7	110-1792	2	Wheel Cover ASM
7:1		1	Cover-Wheel
7:2	614426	1	Washer-Stepped
8	105-1807	2	Arm-Pivot, Front
9	105-1809	2	Arm-Spring
10	105-3042	2	Knob-Lever, HOC
11	32151-36	2	Ring-Retaining
12	104-8698	2	Retainer-Bearing, HOC
13	104-8699	2	Bearing-Ball
14	39-9650	2	Spring-Compression
15	612066	2	Key
16	106-3955	1	Transmission ASM
17	108-9756	1	Gasket-Gearbox
18	46-8091	2	Screw-HWH
19	105-1833-03	1	Bracket-Pivot, Fwd
20	32144-4	2	Screw-HWH
21	92-5791	1	Spacer
22	91-2258	1	V-Belt

Ref	Part No.	Qty.	Description
23	104-8691	2	Pulley-Half, Front
24	3256-24	1	Washer-Flat
25	3296-5	1	Nut-Lock
26	105-1839	1	Cover-Belt, Front
27	36-4780	1	Washer

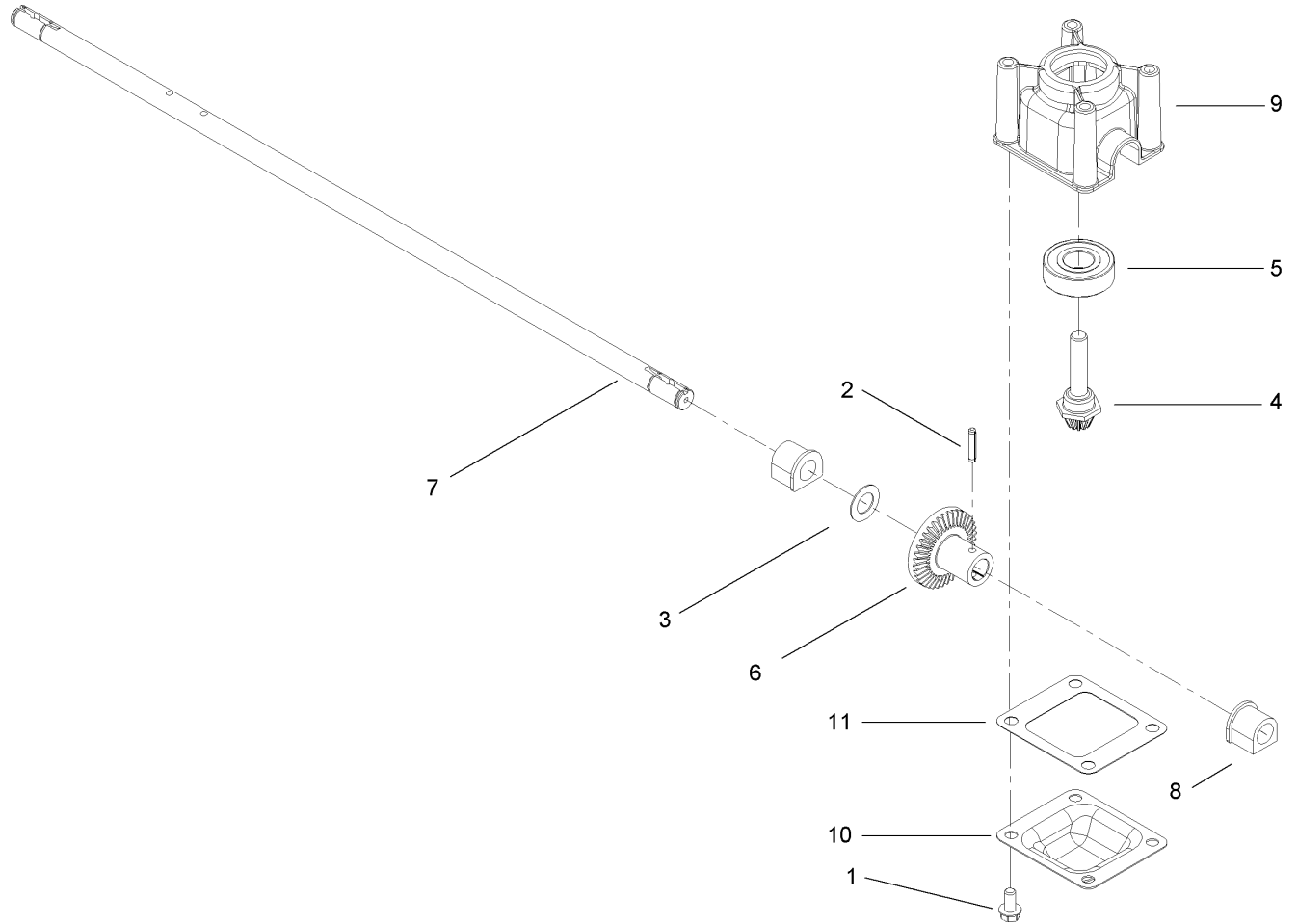

Transmission Assembly No. 106-3955

Ref	Part No.	Qty.	Description
1	32144-4	4	Screw-HWH
2	3285-19	1	Pin-Groove
3	36-4780	1	Washer
4	92-5790	1	Pinion
5	100-1048	1	Bearing-Ball
6	104-8671	1	Gear-Bevel, 37T
7	106-3957	1	Shaft-Output
8	104-8673	2	Bushing-Shaft, Output
9	104-8674	1	Gearcase-Upper
10	104-8675-03	1	Cover-Gearcase
11	105-6839	1	Gasket-Gearcase

--	--	--	--

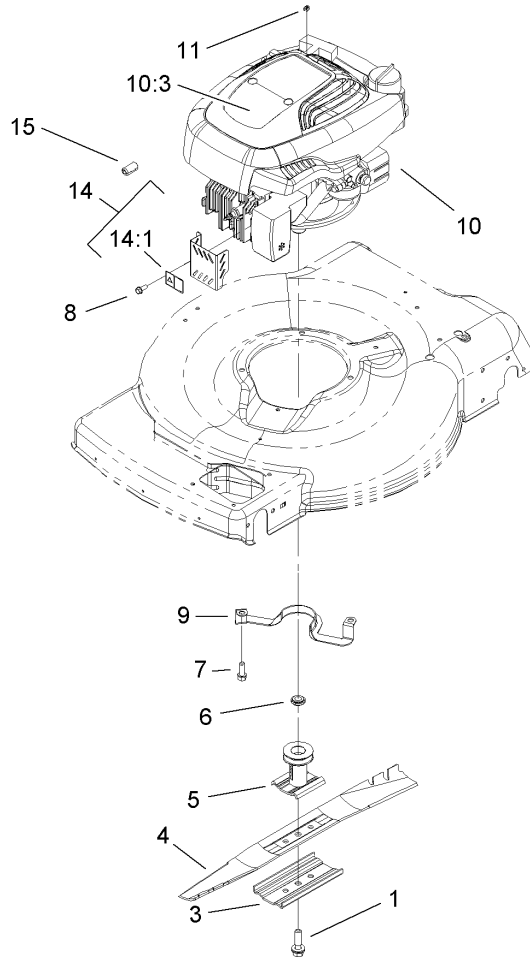

Engine and Blade Assembly

Ref	Part No.	Qty.	Description				
1	105-8579	1	Bolt-Blade				
3	108-3766-03	1	Support-Blade				
4	108-9764-03	1	Blade-22 Inch				
5	106-3987	1	Blade Driver ASM				
6	106-3999	1	Spacer-Driver				
7	95-1726	3	Screw-Taptite				
8	32144-85	1	Screw-HWH				
9	105-3031-03	1	Guide-Belt				
② ⑤ 10		1	Engine-Tecumseh, Lv195-362089D				
10:3	112-8874	1	Decal-Shroud, Engine				
11	92-1701	1	Stop-Rope				
14	106-8387	1	Muffler Guard ASM				
14:1	106-5517	1	Decal-Surface, Hot				
15	112-1540	1	Ferrite-Snap On				

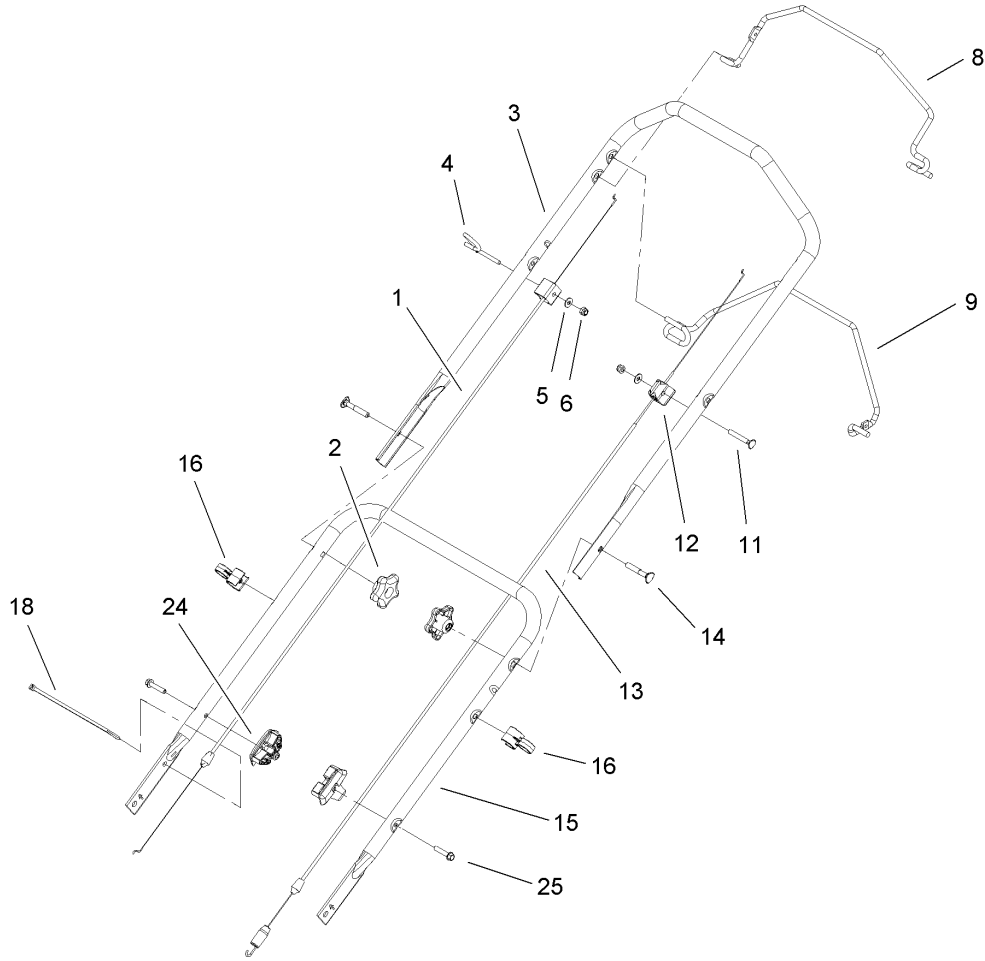

Handle Assembly

Ref	Part No.	Qty.	Description
1	104-8677	1	Cable-Brake
2	108-8162	2	Knob-Locking
3	108-9789-05	1	Handle-Upper
4	106-8330	1	Guide-Rope
5	3256-1	2	Washer-Flat
6	3296-73	2	Nut-Lock, NI
8	108-9791-03	1	Bail-Brake
9	108-9790-03	1	Bail-Traction
11	95-4453	1	Screw
12	92-7729	1	Anchor-Cable, Upper
13	105-1845	1	Cable-Traction
14	112-8876	2	Screw-Handle
15	112-6440-05	1	Handle-Lower
16	106-6805	2	Guide-Cable
18	614249	1	Strap-Tie
24	108-9788	2	Anchor-Bag
25	32144-110	2	Screw-HWH

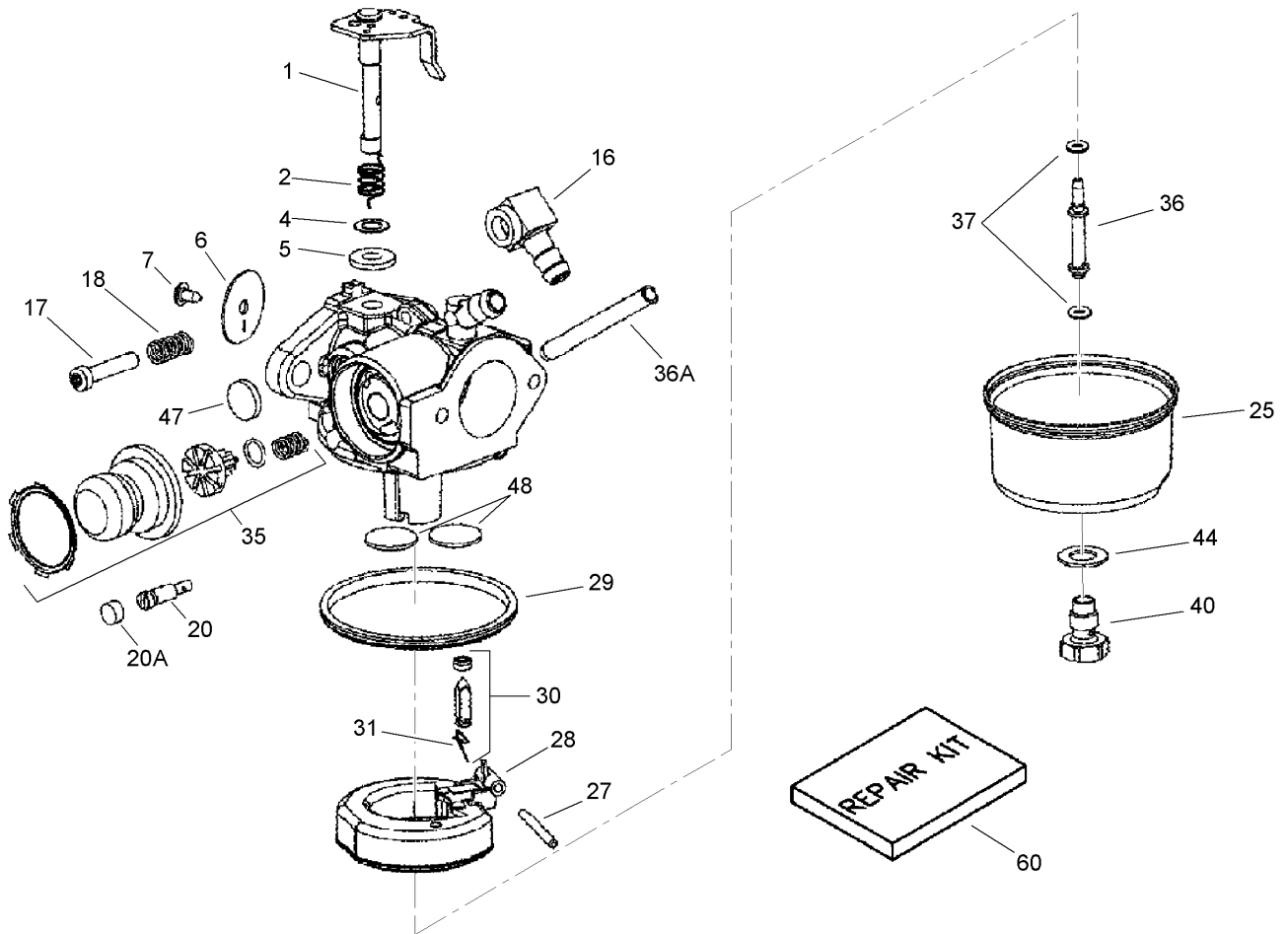

Carburetor Assembly No. 640350 Tecumseh LV195EA-362089D

Ref	Part No.	Qty.	Description
③0	640350	1	Carburetor ASM
③1	631615	1	Throttle Shaft And Lever ASM
③2	631767	1	Spring-Return, Throttle
③④4	631184	1	Washer-Seal, Dust
③④5	631183	1	Seal-Dust, Throttle
③6	640070	1	Shutter-Throttle
③④7	650506	1	Screw-Shutter
③16	631807	1	Fitting-Fuel
③17	651025	1	Screw-Throttle Crack/Idle Speed
③18	630766	1	Spring-Tension
③20	640016	1	Screw-Restrictor, Idle
③20A	640200	1	Cap-Screw, Restrictor Idle
③25	631867	1	Bowl-Float (No Drain)
③④27	631024	1	Shaft-Float
③28	632802	1	Float (Plastic)
③④29	631028	1	O-Ring-Bowl, Float
③④30	631021A	1	Inlet Needle, Seat And Clip ASM (Includes 31)
③31	631022	1	Clip-Spring
③35	640351	1	Primer Bulb/Valve Repair Kit
③36	640080	1	Tube-Nozzle, Main
③36A	632766	1	Tube-Carburetor
③④37	632547	2	O-Ring-Nozzle Tube, Main
③40	640030	1	Nut-Bowl, High Speed

Ref	Part No.	Qty.	Description
③④44	27110A	1	Washer-Nut, Bowl
③④47	630748	1	Plug-Welch, Idle Mixture Well
③④48	631027	2	Plug-Welch, Atmospheric Vent
③60	632760B	1	Repair Kit

Engine Assembly No. 1

Tecumseh LV195EA-362089D

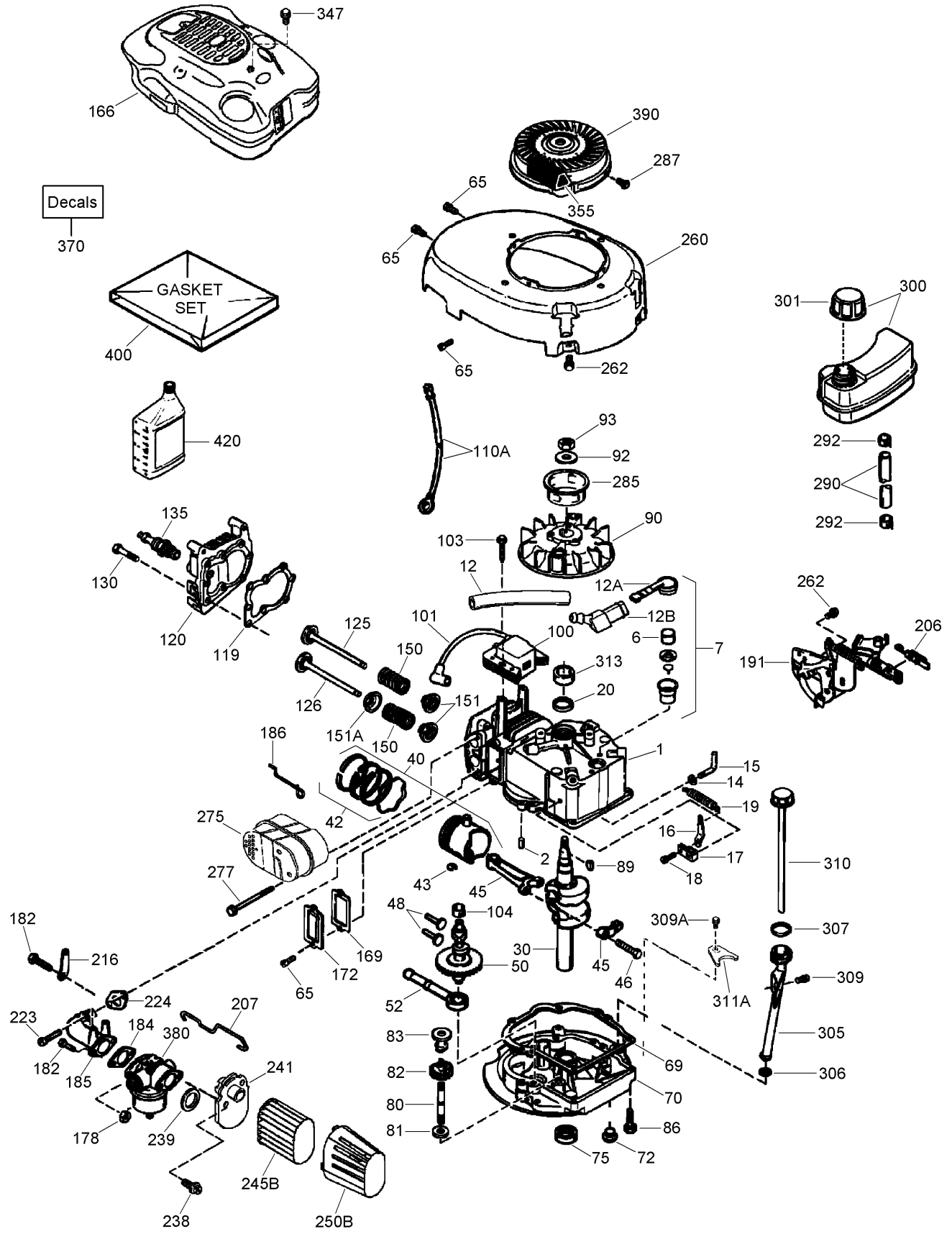

Engine Assembly No. 1

Tecumseh LV195EA-362089D

Ref	Part No.	Qty.	Description	Ref	Part No.	Qty.	Description
③1	37465	1	Cylinder ASM (Includes 2, 20)	③126	37289	1	Intake Valve (STD) (Includes 151)
③2	26727	2	Pin-Dowel	③130	6021A	8	Screw (5/16-18X1-1/2)
③6	33734	1	Element-Breather				
③7	36557	1	Breather ASM (Includes 6, 12A)				
③12	37944	1	Tube-Breather				
③12A	36558	1	Breather Cover And Tube ASM				
③12B	36694	1	Elbow-Tube, Breather				
③14	28277	1	Washer-Flat				
③15	30589	1	Governor Rod ASM (Includes 14)				
③16	34839A	1	Lever-Governor				
③17	31335	1	Clamp-Lever, Governor				
③18	651018	1	Screw (T-15, 8-32 X 19/64)				
③19	36281	1	Spring-Extension				
③20	32600	1	Seal-Oil				
③30	37692	1	Crankshaft				
③40	40045	1	Piston, Pin And Ring Set (.010 O S) (Includes 42)				
③40	40044	1	Piston, Pin And Ring Set (STD) (Includes 42)				
③42	40007	1	Ring Set (.010 O S)				
③42	40006	1	Ring Set (STD)				
③43	20381	2	Ring-Retaining, Piston Pin				
③45	36777	1	Connecting Rod ASM (Includes 46)				
③46	32610A	2	Bolt-Rod, Connecting				
③48	27241	2	Lifter-Valve				
③50	37460	1	Camshaft (Exhaust M C R) (Includes 104)				
③52	29914	1	Oil Pump ASM				
③65	30200	4	Screw (10-24 X 9/16)				
③69	37609	1	Gasket-Flange, Mounting				
③70	37608A	1	Mounting Flange ASM (Includes 72-83, 306, 309A, 311A)				
③72	37614	1	Plug-Drain, Oil (Flush Mount)				
③75	27897	1	Seal-Oil				
③80	30574A	1	Shaft-Governor				
③81	30590A	1	Washer				
③82	30591	1	Governor Gear ASM (Includes 81)				
③83	30588A	1	Spool-Governor				
③86	650488	6	Screw (1/4-20 X 1-1/4)				
③89	611298	1	Key-Flywheel				
③90	611299	1	Flywheel				
③92	650815	1	Washer-Belleville				
③93	650816	1	Nut-Flywheel				
③100	34443C	1	Ignition-Solid State				
③101	611289	1	Cover-Spark Plug				
③103	651007	2	Screw (T-15, 10-24 X 15/16)				
③104	37480	1	Bushing-Cam				
③110A	37047	1	Wire-Ground (10.50 With Male And Female Flag Terminals)				
③119	37796	1	Gasket-Head, Cylinder				
③120	37714	1	Head-Cylinder				
③125	37288	1	Exhaust Valve (STD) (Includes 151)				

Engine Assembly No. 2

Tecumseh LV195EA-362089D

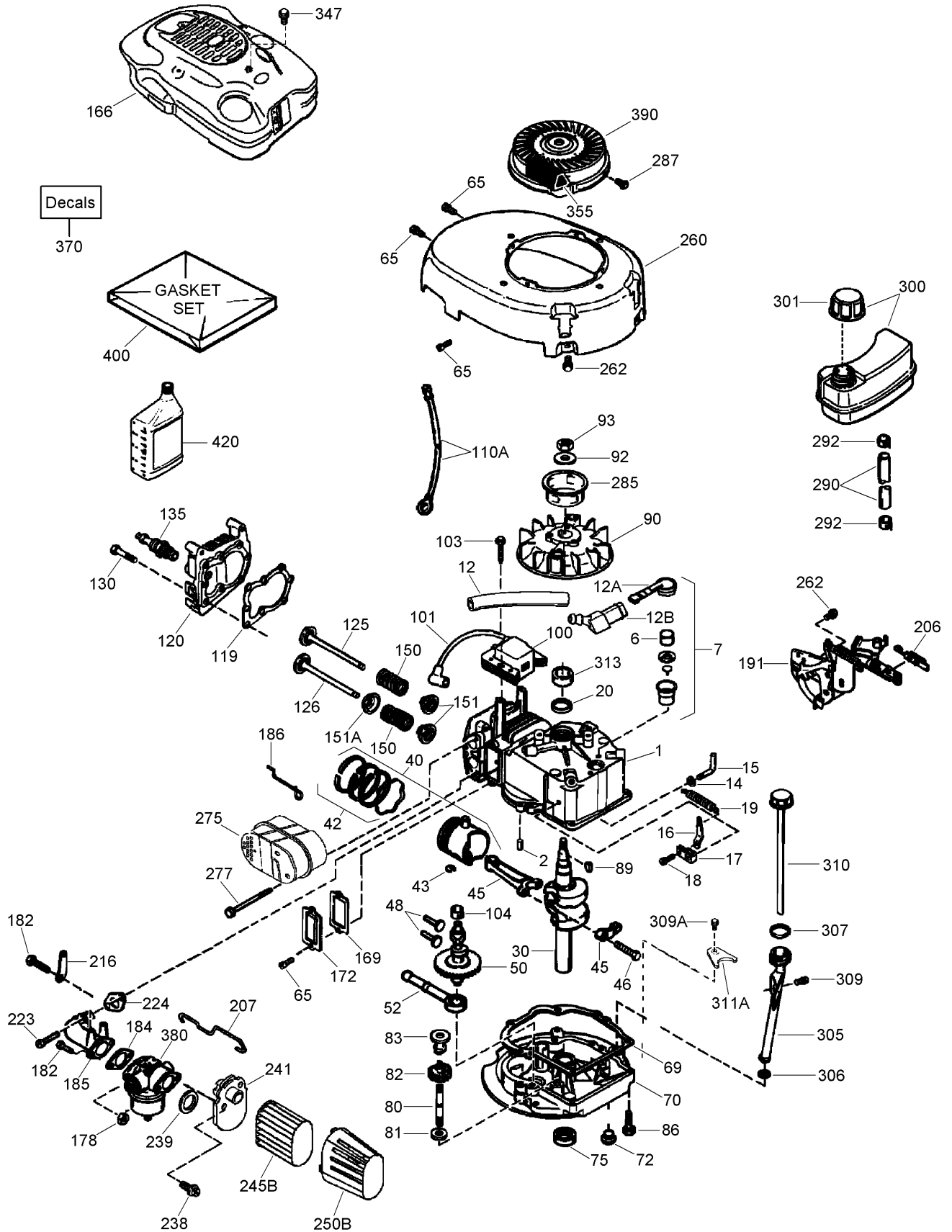

Engine Assembly No. 2

Tecumseh LV195EA-362089D

Ref	Part No.	Qty.	Description	Ref	Part No.	Qty.	Description
③135	35395	1	Spark Plug-Resistor (R J19 L M)	①③0	806173B	1	Replacement Engine
③150	31672	2	Spring-Valve	①③0	750876	1	Shortblock-Replacement
③151	31673	2	Cap-Valve, Spring				
③151A	40017	1	Seal-Valve, Intake				
③166	38019	1	Engine Shroud				
③169	36783	1	Gasket-Cover, Valve				
③172	36784	1	Cover-Valve				
③178	29752	2	Nut And Lock Washer (1/4-28)				
③182	6201	2	Screw (1/4-28 X 7/8)				
③184	26756	1	Gasket-Carburetor To Intake Pipe				
③185	37466	1	Pipe-Intake				
③186	32653	1	Link-Governor				
③191	36559B	1	S E Brake Bracket ASM (Includes 206)				
③206	610973	1	Terminal				
③207	34336A	1	Link-Throttle				
③216	33086	1	Lever-Adjusting, R P M				
③223	650451	2	Screw (1/4-20 X 1)				
③224	36786	1	Gasket-Pipe, Intake				
③238	650932	2	Screw (10-32 X 49/64)				
③239	34338	1	Gasket-Air Cleaner				
③241	36919	1	Collar-Air Cleaner				
③245B	36905	1	Filter-Air Cleaner (Paper)				
③250B	37122	1	Cover-Air Cleaner				
③260	37696A	1	Housing-Blower				
③262	650831	2	Screw (1/4-20 X 1/2)				
③275	37498	1	Muffler				
③277	650988	2	Screw (1/4-20 X 2-9/32)				
③285	35000A	1	Cup-Starter				
③287	650926	2	Screw (8-32 X 21/64)				
③290	37962	1	Line-Fuel, Low Permeation (8.62)				
③292	26460	2	Clamp-Line, Fuel				
③300	37947	1	Fuel Tank ASM (Includes 292, 301)				
③301	37844	1	Cap-Fuel (Black) (1-1/2 I D)				
③305	35647A	1	Tube-Fill, Oil				
③306	37610	1	O-Ring				
③307	35499	1	O-Ring				
③309	650562	1	Screw (10-32 X 1/2)				
③309A	650783	1	Screw (10-24 X 3/4)				
③310	35648	1	Dipstick				
③311A	37611	1	Bracket-Holddown				
③313	34080	1	Spacer				
③347	650898A	4	Screw (10-32 X 27/32)				
③355	590701	1	Handle-Starter (STD)				
③370	37695	1	Decal-Primer				
③370	35977	1	Decal-Warning				
③380	640350	1	Carburetor ASM				
③390	590702	1	Starter-Recoil				
③400	37613A	1	Gasket Set				
③420	730225A	1	Oil-Engine, Sae 30 (4-Cycle)				
①③999	730277	1	Summer Maintenance Kit (Includes Sae 30 Oil)				

Attachments and Accessories

For 20094 - 22in Recycler Lawn Mower

Product Name	Model/Part
Tuneup Kit	20235
Replacement Bag	59303
Bagger Kit	59304
22 Inch Blade Kit	59534

NOTES

NOTES

