



**Count on it.**

**Operator's Manual**

**Groundsmaster<sup>®</sup> 4100-D  
Traction Unit**

**Model No. 30411—Serial No. 2600000001 and Up**

## Warning

### CALIFORNIA Proposition 65 Warning

Diesel engine exhaust and some of its constituents are known to the State of California to cause cancer, birth defects, and other reproductive harm.

## Introduction

Read this information carefully to learn how to operate and maintain your product properly and to avoid injury and product damage. You are responsible for operating the product properly and safely.

You may contact Toro directly at [www.Toro.com](http://www.Toro.com) for product and accessory information, help finding a dealer, or to register your product.

Whenever you need service, genuine Toro parts, or additional information, contact an Authorized Service Dealer or Toro Customer Service and have the model and serial numbers of your product ready. Write the numbers in the space provided.

**Model No.** \_\_\_\_\_  
**Serial No.** \_\_\_\_\_

This manual identifies potential hazards and has safety messages identified by the safety alert symbol (Figure 1), which signals a hazard that may cause serious injury or death if you do not follow the recommended precautions.



**Figure 1**

1. Safety alert symbol

This manual uses 2 other words to highlight information. **Important** calls attention to special mechanical information and **Note** emphasizes general information worthy of special attention.

## Contents

Introduction .....	2
Safety .....	4
Safe Operating Practices .....	4
Toro Mower Safety .....	6
Sound Pressure Level.....	8
Sound Power Level.....	8
Vibration Level.....	8
Safety and Instructional Decals .....	8
Setup .....	14
1 Installing the Seat, Seat Belt, and Manual Tube .....	14
2 Greasing the Machine .....	14
3 Reading the Manuals and Viewing the DVD .....	15
Product Overview .....	16
Controls .....	16
Specifications .....	18
Operation.....	19
Before Operating.....	19
Starting and Stopping the Engine .....	28
Checking the Interlock Switches .....	29
Pushing or Towing the Machine .....	30
Jacking Points.....	30
Tie Downs .....	30
Operating Characteristics.....	30
Operating Tips .....	31
Maintenance.....	33
Recommended Maintenance Schedule(s) .....	33
Premaintenance Procedures.....	34
Service Interval Chart.....	34
Lubrication.....	34
Greasing the Bearings and Bushings .....	34
Engine Maintenance.....	38
Air Cleaner Maintenance.....	38
Servicing the Engine Oil and Filter .....	39
Fuel System Maintenance .....	40
Servicing the Fuel System .....	40
Bleeding Air from the Injectors.....	41
Electrical System Maintenance.....	41
Activating, Charging, and Connecting the Battery .....	41

Battery Care .....	43	Inspecting and Sharpening the Cutter Blade(s) .....	56
Fuses.....	43	Correcting Cutting Unit Mismatch .....	57
Drive System Maintenance.....	43	Spark Arrestor Maintenance .....	57
Changing the Planetary Gear Drive Oil.....	43	Servicing the Spark Arrestor Muffler.....	57
Changing the Rear Axle Lubricant .....	44	Storage.....	59
Checking the Rear Wheel Toe-In.....	45	Preparing for Seasonal Storage.....	59
Cooling System Maintenance .....	45	Schematics .....	60
Servicing the Engine Cooling System.....	45		
Brake Maintenance .....	45		
Adjusting the Service Brakes .....	45		
Belt Maintenance.....	46		
Servicing the Alternator Belt .....	46		
Re-tensioning the Blade Drive Belts.....	46		
Replacing the Blade Drive Belt .....	46		
Controls System Maintenance.....	47		
Adjusting the Throttle .....	47		
Adjusting the Traction Pedal Linkage .....	47		
Hydraulic System Maintenance .....	48		
Changing the Hydraulic Fluid.....	48		
Replacing the Hydraulic Filters.....	48		
Checking the Hydraulic Lines and Hoses.....	49		
Hydraulic System Test Ports.....	49		
Adjusting the Cutting Unit Flow Control .....	51		
Mower Maintenance .....	51		
Pivoting (Tilting) the Front Cutting Unit Upright.....	51		
Pivoting the Front Cutting Unit Down.....	52		
Adjusting the Cutting Unit Pitch.....	52		
Servicing the Castor Arm Bushings .....	53		
Servicing the Castor Wheels and Bearings .....	53		
Replacing the Cutting Unit Hinge Covers.....	54		
Tightening the Locknuts .....	54		
Blade Maintenance .....	55		
Checking for a Bent Blade.....	55		
Removing and Installing the Cutter Blade(s) .....	55		

# Safety

This machine meets or exceeds CEN standard EN 836:1997, ISO standard 5395:1990, and ANSI B71.4-1999 specifications in effect at the time of production.

Improper use or maintenance by the operator or owner can result in injury. To reduce the potential for injury, comply with these safety instructions and always pay attention to the safety alert symbol, which means Caution, Warning, or Danger—personal safety instruction. Failure to comply with the instruction may result in personal injury or death.

## Safe Operating Practices

The following instructions are from the CEN standard EN 836:1997, ISO standard 5395:1990, and ANSI standard B71.4-1999.

### Training

- Read the *Operator's Manual* and other training material carefully. Be familiar with the controls, safety signs, and the proper use of the equipment.
- Never allow children or people unfamiliar with these instructions to use the mower. Local regulations may restrict the age of the operator.
- Never mow while people, especially children, or pets are nearby.
- Keep in mind that the operator or user is responsible for accidents or hazards occurring to himself or herself, other people, or property.
- Do not carry passengers.
- All drivers and mechanics should seek and obtain professional and practical instruction. The owner is responsible for training the users. Such instruction should emphasize:
  - the need for care and concentration when working with ride-on machines;
  - control of a ride-on machine sliding on a slope will not be regained by the application of the brake. The main reasons for loss of control are:
    - ◊ insufficient wheel grip;
    - ◊ being driven too fast;

- ◊ inadequate braking;
- ◊ the type of machine is unsuitable for its task;
- ◊ lack of awareness of the effect of ground conditions, especially slopes;
- ◊ incorrect hitching and load distribution.

- The owner/user can prevent and is responsible for accidents or injuries occurring to himself or herself, other people, or property.

### Preparation

- While mowing, always wear substantial footwear, long trousers, hard hat, safety glasses, and ear protection. Long hair, loose clothing or jewelry may get tangled in moving parts. Do not operate the equipment when barefoot or wearing open sandals.
- Thoroughly inspect the area where the equipment is to be used and remove all objects which may be thrown by the machine.
- **Warning**—fuel is highly flammable. Take the following precautions:
  - Store fuel in containers specifically designed for this purpose.
  - Refuel outdoors only and do not smoke while refuelling.
  - Add fuel before starting the engine. Never remove the cap of the fuel tank or add fuel while the engine is running or when the engine is hot.
  - If fuel is spilled, do not attempt to start the engine but move the machine away from the area of spillage and avoid creating any source of ignition until fuel vapors have dissipated.
  - Replace all fuel tank and container caps securely.
- Replace faulty silencers/mufflers.
- Before using, always visually inspect to see that the blades, blade bolts, and cutting assembly are not worn or damaged. Replace worn or damaged blades and bolts in sets to preserve balance.
- On multi-bladed machines, take care as rotating one blade can cause other blades to rotate.

- Evaluate the terrain to determine what accessories and attachments are needed to properly and safely perform the job. Only use accessories and attachments approved by the manufacturer.
- Check that operators presence controls, safety switches, and shields are attached and functioning properly. Do not operate unless they are functioning properly.
- Never operate the machine with damaged guards, shields, or without safety protective devices in place. Be sure all interlocks are attached, adjusted properly, and functioning properly.
- Do not change the engine governor settings or overspeed the engine. Operating the engine at excessive speed may increase the hazard of personal injury.

## Operation

- Do not operate the engine in a confined space where dangerous carbon monoxide fumes can collect.
- Mow only in daylight or in good artificial light.
- Before attempting to start the engine, disengage all blade attachment clutches, shift into neutral, and engage the parking brake. Only start the engine from the operators position. Use seat belts, if provided.
- Do not use this machine on slopes greater than 13°.
- Remember there is no such thing as a safe slope. Travel on grass slopes requires particular care. To guard against overturning:
  - Do not stop or start suddenly when going up or downhill.
  - Engage the clutch slowly, always keep the machine in gear, especially when travelling downhill.
  - The machine speed should be kept low on slopes and during tight turns.
  - Stay alert for humps and hollows and other hidden hazards.
  - Never mow across the face of the slope, unless the machine is designed for that purpose.
- Stay alert for holes in the terrain and other hidden hazards.
- Watch out for traffic when crossing or near roadways.
- Stop the blades from rotating before crossing surfaces other than grass.
- When using any attachments, never direct discharge of material toward bystanders nor allow anyone near the machine while in operation.
- Before leaving the operators position:
  - Stop on level ground.
  - Disengage the power take-off and lower the attachments.
  - Change into neutral and set the parking brake.
  - Stop the engine and remove the key.
- Disengage drive to attachments, stop the engine, and disconnect the spark plug wire(s) or remove the ignition key:
  - before clearing blockages;
  - before checking, cleaning, or working on the machine;
  - after striking a foreign object. Inspect the machine for damage and make repairs before restarting and operating the equipment. Torque all the spindle pulley nuts to 130 to 150 ft-lb (176 to 203 N·m);
  - if the machine starts to vibrate abnormally (check immediately).
- Disengage drive to attachments when transporting or not in use.
- Stop the engine and disengage drive to attachment:
  - before refuelling;
  - before making height adjustment unless adjustment can be made from the operator's position.
- Reduce the throttle setting before stopping engine and, if the engine is provided with a fuel shut-off valve, turn the fuel off at the conclusion of mowing.
- Never raise deck with the blades running.
- Keep hands and feet away from the cutting units.

- Look behind and down before backing up to be sure of a clear path.
- Slow down and use caution when making turns and crossing roads and sidewalks.
- Slow down and use caution when making turns and crossing roads and sidewalks.
- Do not operate the mower under the influence of alcohol or drugs.
- Use care when loading or unloading the machine into a trailer or truck.
- Use care when approaching blind corners, shrubs, trees, or other objects that may obscure vision.
- The operator shall turn on flashing warning lights, if provided, whenever traveling on a public road, except where such use is prohibited by law.
- Use jack stands to support components when required.
- Carefully release pressure from components with stored energy.
- Disconnect battery or remove spark plug wire before making any repairs. Disconnect the negative terminal first and the positive last. Reconnect positive first and negative last.
- Use care when checking blades. Wrap the blades or wear gloves, and use caution when servicing them. Only replace blades. Never straighten or weld them.
- Keep hands and feet away from moving parts. If possible, do not make adjustments with the engine running.
- Charge batteries in an open well ventilated area, away from spark and flames. Unplug charger before connecting or disconnecting from battery. Wear protective clothing and use insulated tools.

## Maintenance and Storage

- Keep all nuts, bolts, and screws tight to be sure the equipment is in safe working condition.
- Never store the equipment with fuel in the tank inside a building where fumes may reach an open flame or spark.
- Allow the engine to cool before storing in any enclosure and do not store near flame.
- To reduce the fire hazard, keep the engine, silencer/muffler, battery compartment, cutting units, drives, and fuel storage area free of grass, leaves, or excessive grease. Clean up oil or fuel spillage.
- Replace worn or damaged parts for safety.
- If the fuel tank has to be drained, do this outdoors.
- On multi-bladed machines, take care as rotating one blade can cause other blades to rotate.
- When machine is to be parked, stored, or left unattended, lower the cutting units unless a positive mechanical lock is provided.
- Disengage drives, lower the cutting units, move traction pedal to Neutral, set parking brake, stop engine and remove key and disconnect spark plug wire. Wait for all movement to stop before adjusting, cleaning or repairing.
- Shut off fuel while storing or transporting. Do not store fuel near flames.
- Park machine on level ground. Never allow untrained personnel to service machine.

## Toro Mower Safety

The following list contains safety information specific to Toro products or other safety information that you must know that is not included in the CEN, ISO, or ANSI standards.

This product is capable of amputating hands and feet and throwing objects. Always follow all safety instructions to avoid serious injury or death.

Use of this product for purposes other than its intended use could prove dangerous to user and bystanders.



**Engine exhaust contains carbon monoxide, which is an odorless, deadly poison that can kill you.**

**Do not run engine indoors or in an enclosed area.**

## Operation

- Before operating a machine with ROPS (roll over protection system), be certain that the seat belts are attached and the seat is latched to prevent the seat from pivoting forward.
- Know how to stop the machine and engine quickly.

- Do not operate the machine while wearing tennis shoes or sneakers.
- Wearing safety shoes and long pants is advisable and required by some local ordinances and insurance regulations.
- Keep hands, feet, and clothing away from moving parts and the mower discharge area and underside of the mower while the engine is running.
- Fill fuel tank until level is 1 inch (25 mm) below the bottom of the filler neck. Do not overfill.
- Check the safety interlock switches daily for proper operation. If a switch should fail, replace the switch before operating the machine. After every two years, replace all interlock switches in the safety system, **regardless** if they are working properly or not.
- Check carefully for overhead clearances (i.e. branches, doorways, electrical wires) before driving under any objects and do not contact them.
- Do not mow in reverse unless absolutely necessary.
- Reduce speed when making sharp turns.
- If a steep slope must be ascended, back up the hill and drive forward down the hill, keeping the machine in gear.
- If you cannot back up a slope or if you feel uneasy on it, do not mow it.
- Avoid starting or stopping on a slope. If tires lose traction, disengage the blades and proceed slowly straight down the slope. Avoid raising the side cutting units on a slope.
- Avoid turning on slopes. If you must turn, turn slowly and gradually downhill, if possible.
- When operating the machine on slopes, banks, or near drop-offs, always have the ROPS installed.
- When operating a machine with a ROPS, always use a seat belt.
- Be certain that the seat belt can be released quickly if the machine is driven or rolls into a pond or water.
- Watch for traffic when near or crossing roads. Always yield the right-of-way.
- Do not mow near drop-offs, ditches, or embankments. The machine could suddenly turn over if a wheel goes over the edge of a cliff or ditch, or if an edge caves in.
- Do not mow on wet grass. Reduced traction could cause sliding.
- Do not try to stabilize the machine by putting your foot on the ground.
- Use extra care with other attachments. These can change the stability of the machine.
- When a person or pet appears unexpectedly in or near the mowing area, **stop mowing**. Careless operation, combined with terrain angles, ricochets, or improperly positioned guards can lead to thrown object injuries. Do not resume mowing until the area is cleared.
- Turn off the blades when not mowing.

## Maintenance and Storage

- Do not touch equipment or attachment parts which may be hot from operation. Allow to cool before attempting to maintain, adjust, or service.
- Never store the machine or fuel container inside where there is an open flame, such as near a water heater or furnace.
- Keep nuts and bolts tight, especially the blade attachment bolts. Keep equipment in good condition.
- Make sure all hydraulic line connectors are tight and all hydraulic hoses and lines are in good condition before applying pressure to the system.
- Keep your body and hands away from pin hole leaks or nozzles that eject hydraulic fluid under high pressure. Use paper or cardboard, not your hands, to search for leaks. Hydraulic fluid escaping under pressure can have sufficient force to penetrate the skin and cause serious injury. If fluid is injected into the skin it must be surgically removed within a few hours by a doctor familiar with this form of injury or gangrene may result.
- If the engine must be running to perform a maintenance adjustment, keep hands, feet, clothing, and any parts of the body away from the cutting units, attachments, and any moving parts. Keep everyone away.
- Check brake operation frequently. Adjust and service as required.

- Battery acid is poisonous and can cause burns. Avoid contact with skin, eyes, and clothing. Protect your face, eyes, and clothing when working with a battery.
- Battery gases can explode. Keep cigarettes, sparks, and flames away from the battery.
- The engine must be shut off before checking the oil or adding oil to the crankcase.
- If major repairs are ever needed or if assistance is desired, contact an Authorized Toro Distributor.
- To make sure of optimum performance and continued safety certification of the machine, use only genuine Toro replacement parts and accessories. Replacement parts and accessories made by other manufacturers could be dangerous, and such use could void the product warranty.

## Sound Pressure Level

This unit has an equivalent continuous A-weighted sound pressure level at the operator ear of 89 dBA,

based on measurements of identical machines per EN 11094 and EN 836.

## Sound Power Level

This unit has an equivalent continuous A-weighted sound power level at the operator ear of 105 dBA/1 pW, based on measurements of identical machines per EN 11094.

## Vibration Level

### Hand-Arm

This unit has an equivalent continuous A-weighted hand/arm vibration level of 2.5 m/s<sup>2</sup>, based on measurements of identical machines per EN 1033.

### Whole Body

This unit has an equivalent continuous A-weighted hand/arm vibration level of 0.5 m/s<sup>2</sup>, based on measurements of identical machines per EN 1033.

## Safety and Instructional Decals



Safety decals and instructions are easily visible to the operator and are located near any area of potential danger. Replace any decal that is damaged or lost.

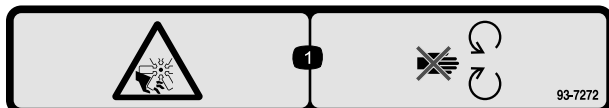

**93-7272**

1. Cutting/dismemberment hazard; fan—stay away from moving parts.

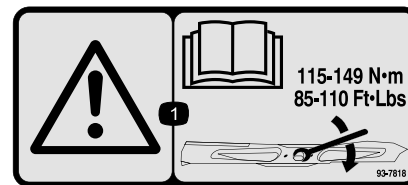

**93-7818**

1. Warning—read the *Operator's Manual* for instructions on torquing the blade bolt/nut to 115 to 149 N•m (85 to 110 ft-lb).

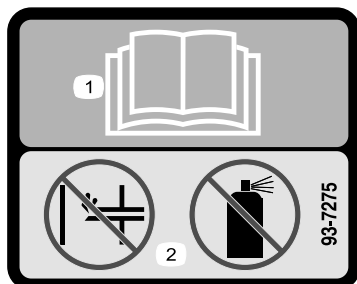

**93-7275**

1. Read the *Operator's Manual*.
2. Do not use starting aids.

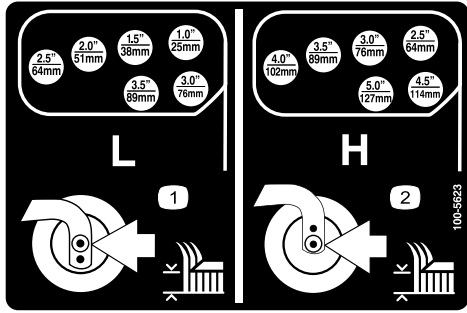

**100-5623**

1. Low height of cut adjustment
2. High height of cut adjustment

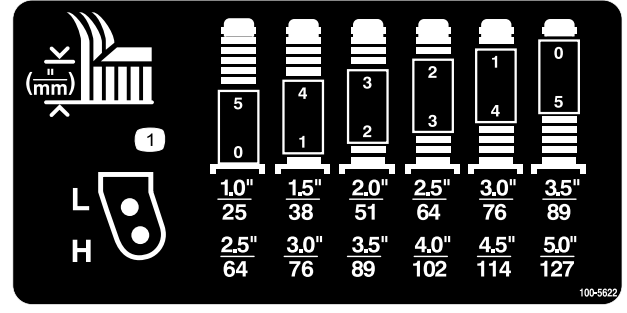

**100-5622**

1. Height of cut adjustment

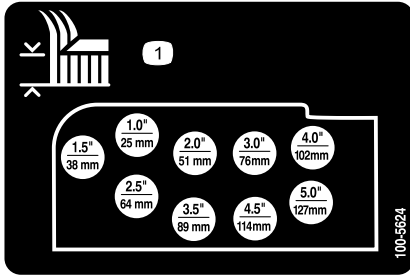

**100-5624**

1. Height of cut adjustment

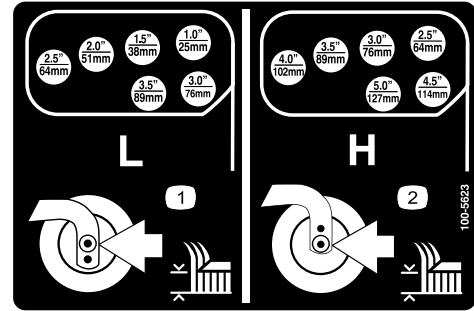

**100-5623**

1. Low height of cut adjustment
2. High height of cut adjustment

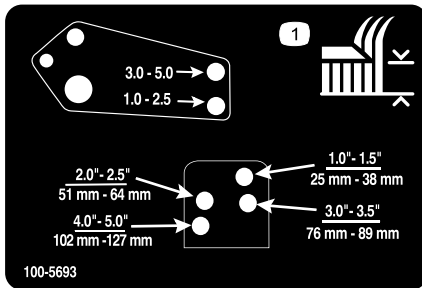

**100-5693**

1. Height of cut adjustment

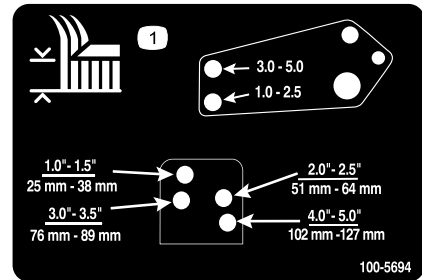

**100-5694**

1. Height of cut adjustment

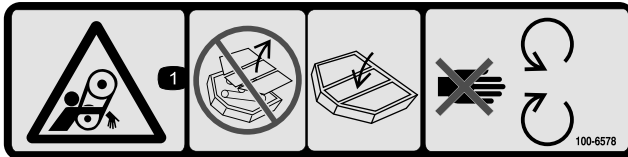

**100-6578**

1. Entanglement hazard, belt—do not operate the machine with the shields or guards removed; always keep the shields and guards in place; stay away from moving parts.

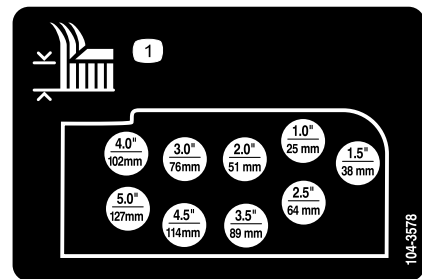

**104-3578**

1. Height of cut adjustment



**104-2277**

1. To lock the parking brake, latch the pedals together, apply the brake pedals, and pull up on the knob.
2. To unlock the parking brake, step on the brake pedals.
3. Parking brake lock indicator
4. Read the *Operator's Manual*.
5. Press for optional headlights.
6. Press down on the lever to tilt the steering wheel.

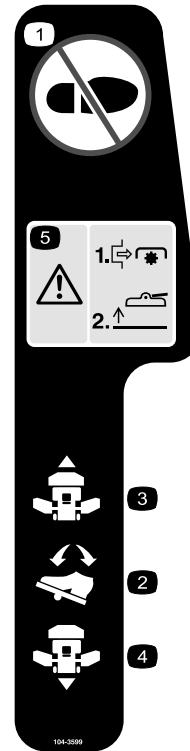

**104-3599**

1. Do not step here.
2. Traction pedal
3. Traction—forward
4. Traction—reverse
5. Danger—shut off PTO prior to raising the cutting units; do not operate the cutting units when they are in the raised position.

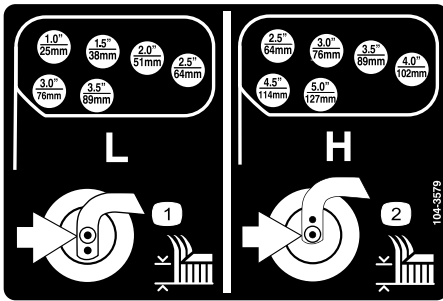

**104-3579**

1. Low height of cut adjustment
2. High height of cut adjustment



**104-8324**

1. Raise cutting units
2. Lower cutting units



1. Lock/unlock the cutting unit service lock.

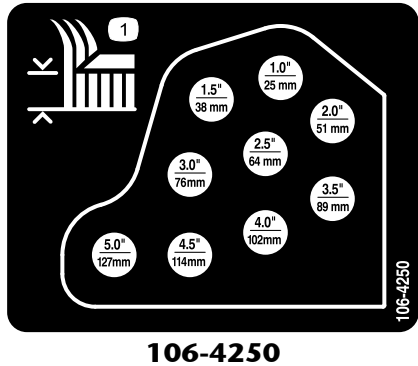

1. Height of cut

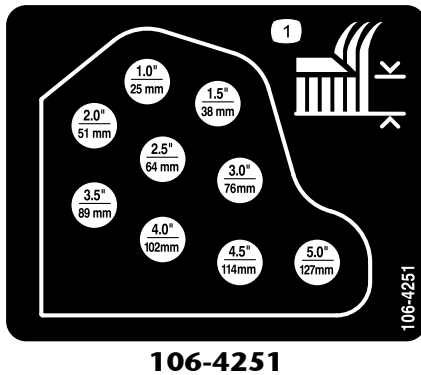

1. Height of cut

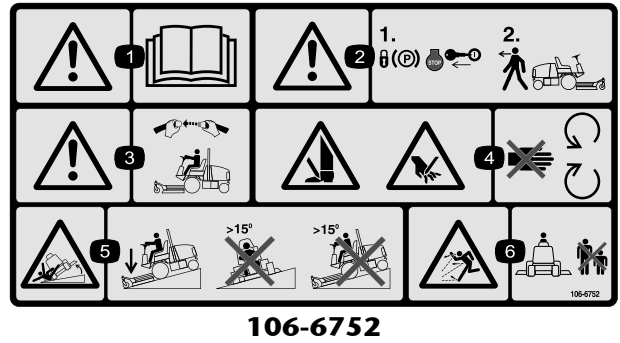

1. Warning—read the *Operator's Manual*.
2. Warning—lock the parking brake, stop the engine, and remove the ignition key before leaving the machine.
3. Warning—wear the seat belt when seated in the operator's position.
4. Cutting hazard of hand or foot—stay away from moving parts.
5. Tipping hazard—lower the cutting unit when driving down slopes; do not drive on slopes greater than 15 degrees.
6. Thrown object hazard—keep bystanders a safe distance from the machine.

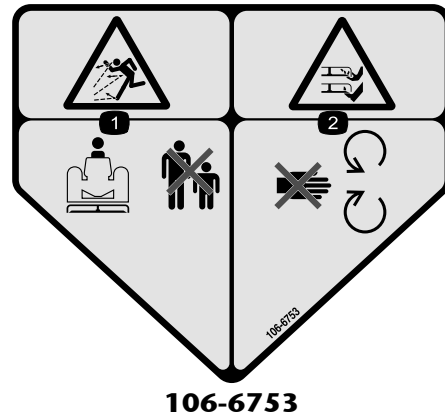

1. Engine coolant under pressure
2. Explosion hazard—read the *Operator's Manual*.
3. Warning—do not touch the hot surface.
4. Warning—read the *Operator's Manual*.

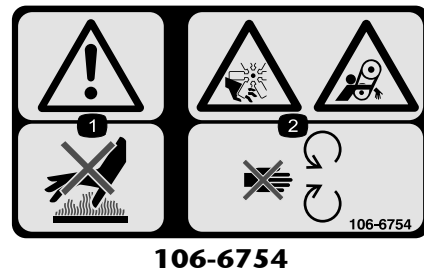

1. Warning—do not touch the hot surface.
2. Cutting/dismemberment hazard, fan and entanglement hazard, belt—stay away from moving parts.



**106-6755**

1. Engine coolant under pressure.
2. Explosion hazard—read the *Operator's Manual*.
3. Warning—do not touch the hot surface.
4. Warning—read the *Operator's Manual*.

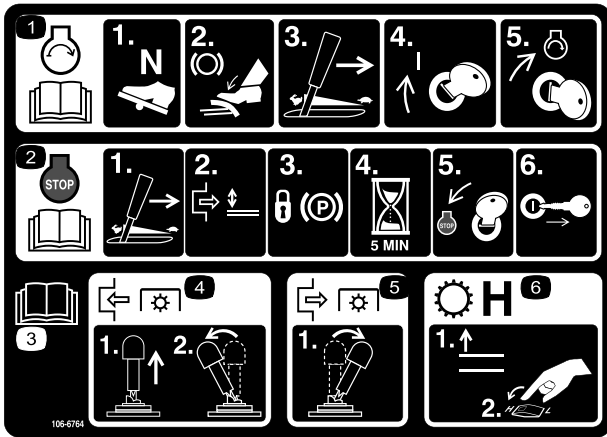

**106-6764**

1. To start the engine, move the traction pedal to Neutral, press the brake pedal, move the throttle lever to Fast, turn the ignition key to On, and then turn the ignition key to Start; read the *Operators Manual*.
2. To stop the engine, move the throttle lever to slow, disengage the PTO, set the parking brake, wait 5 minutes, turn the ignition key to Stop, and remove the key; read the *Operators Manual*.
3. Read the *Operators Manual*.
4. To engage the PTO, pull up on the PTO switch and move it forward.
5. To disengage the PTO, move the PTO switch back.
6. To switch the transmission to high speed, raise the attachment lift and switch the speed control to High.

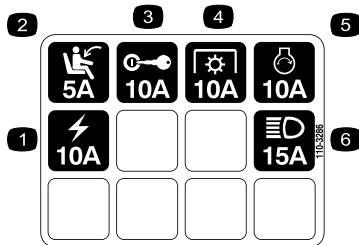

**110-3286**

1. Power outlet
2. Seat switch
3. Ignition switch
4. Power Take Off (PTO)
5. Starter solenoid
6. Light Kit



**Battery Symbols**

Some or all of these symbols are on your battery

1. Explosion hazard
2. No fire, open flame, or smoking.
3. Caustic liquid/chemical burn hazard
4. Wear eye protection
5. Read the *Operator's Manual*.
6. Keep bystanders a safe distance from the battery.
7. Wear eye protection; explosive gases can cause blindness and other injuries
8. Battery acid can cause blindness or severe burns.
9. Flush eyes immediately with water and get medical help fast.
10. Contains lead; do not discard.

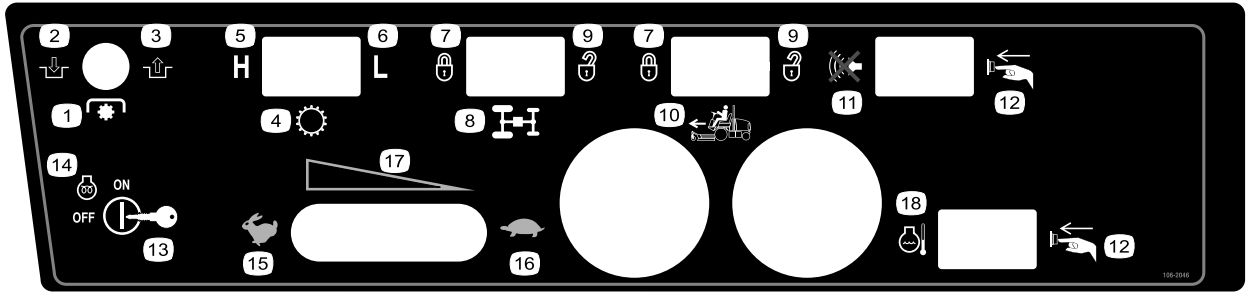

**106-2046**

- |                         |                               |                      |   |
|-------------------------|-------------------------------|----------------------|---|
| 1. Power Take-off (PTO) | 6. Low                        | 11. Silencer switch  | 16. Slow                                    |
| 2. Engage               | 7. Lock                       | 12. Press the button | 17. Continuous variable setting             |
| 3. Disengage            | 8. Flow divider               | 13. Key switch       | 18. Engine coolant temperature reset switch |
| 4. Transmission         | 9. Unlock                     | 14. Engine—preheat   |   |
| 5. High                 | 10. Cruise control (optional) | 15. Fast             |   |

## GROUNDMASTER 4000

### QUICK REFERENCE AID

**CHECK/SERVICE (DAILY)**

1. ENGINE OIL LEVEL
2. HYDRAULIC FLUID LEVEL
3. ENGINE COOLANT LEVEL
4. FUEL - DIESEL ONLY
5. FUEL/WATER SEPARATOR
6. FAN BELT TENSION
7. RADIATOR SCREEN
8. AIR CLEANER
9. BRAKE FUNCTION
10. INTERLOCK SYSTEM
11. TIRE PRESSURE - 25 PSI / 1.70 BAR
12. GREASE POINTS (6)

SEE OPERATOR'S MANUAL FOR 50 HR INTERVAL GREASE POINTS.

**SPECIFICATIONS/CHANGE INTERVALS**

SEE OPERATOR'S MANUAL FOR INITIAL CHANGES.	FLUID TYPE	CAPACITY	CHANGE INTERVAL		FILTER PART NO.
			FLUID	FILTER	
ENGINE OIL	10W-30 CE	8 QUARTS	100 HOURS	100 HOURS	98-7431 (A)
HYDRAULIC FLUID	ISO VG 46/68	8 GALLONS	800 HOURS	800 HOURS	75-1310 (B)
HYDRAULIC BREATHER				800 HRS/YRLY	94-2621 (C)
INTERLOCK SWITCHES			2 YEARS		68-6150 (D)
PRIMARY AIR FILTER				SEE SERVICE INDICATOR	104-4260 (E)
SAFETY AIR FILTER				SEE OPERATOR'S MANUAL	104-4261 (F)
FUEL SYSTEM	> 32 F	NO. 2 DIESEL	19 GALLONS	800 HOURS DRAIN/FLUSH	98-9764 (G)
	< 32 F	NO. 1 DIESEL			98-7612 (H)
REAR AXLE	85W-140	80 OUNCES	800 HOURS		99-7591 (J)
PLANETARY DRIVE	85W-140	16 OUNCES	800 HOURS		
ENGINE COOLANT	50% WATER 50% ETHYL GLYCOL	11 QUARTS	DRAIN & FLUSH EVERY 2 YRS.		

**104-8336**

1. Read the *Operator's Manual*.

# Setup

## Loose Parts

Use the chart below to verify that all parts have been shipped.

Step	Description	Qty.	Use
<b>1</b>	Seat kit (obtain separately)	1	Install the seat, seat belt, and manual tube.
	Seat suspension kit (obtain separately)	1	
	Manual tube	1	
	R-clamp	2	
	Seat belt	1	
	Bolt	2	
	Lock washer	2	
<b>2</b>	No parts required	–	Grease the machine.
<b>3</b>	Operator's Manual	1	Read the manuals and watch the DVD before operating the machine. Use the remaining parts for the installation of attachments.
	Engine Operator's Manual	1	
	Parts Catalog	1	
	Operator Training DVD	1	
	Pre-delivery Inspection Sheet	1	
	CE certificate	1	

**Note:** Determine the left and right sides of the machine from the normal operating position.

**Step**  
**1**

## Installing the Seat, Seat Belt, and Manual Tube

### Parts needed for this step:

1	Seat kit (obtain separately)
1	Seat suspension kit (obtain separately)
1	Manual tube
2	R-clamp
1	Seat belt
2	Bolt
2	Lock washer

### Procedure

The machine is shipped without the seat assembly. The Deluxe Seat, Model No. 30398, and Seat Suspension Kit, Model No. 30396 or the Premium Seat, Model No. 30622, and Premium Suspension

Kit, Model No. 30621, must be purchased and installed.

1. Mount the manual tube to the seat suspension with the 2 R-clamps included in loose parts.
2. Install the seat belt to each side of the seat with a bolt and lock washer, supplied in loose parts.

**Important:** Make sure that the seat switch wire is connected to the seat switch connector on the harness.

3. Slide the seat completely forward and backward to ensure proper operation and that seat switch wires and connectors are not pinched or do no contact any moving parts.

**Step**  
**2**

## **Greasing the Machine**

### **No Parts Required**

### **Procedure**

Before the machine is operated, it must be greased to ensure proper lubricating characteristics; refer to Greasing the Bearings and Bushings procedure of Lubrication, page 34. Failure to properly grease the machine will result in premature failure of critical parts.

**Step**  
**3**

## **Reading the Manuals and Viewing the DVD**

### **Parts needed for this step:**

1	<i>Operator's Manual</i>
1	<i>Engine Operator's Manual</i>
1	<i>Parts Catalog</i>
1	Operator Training DVD
1	Pre-delivery Inspection Sheet
1	CE certificate

### **Procedure**

1. Read the manuals.
2. View the Operator Training DVD.

# Product Overview

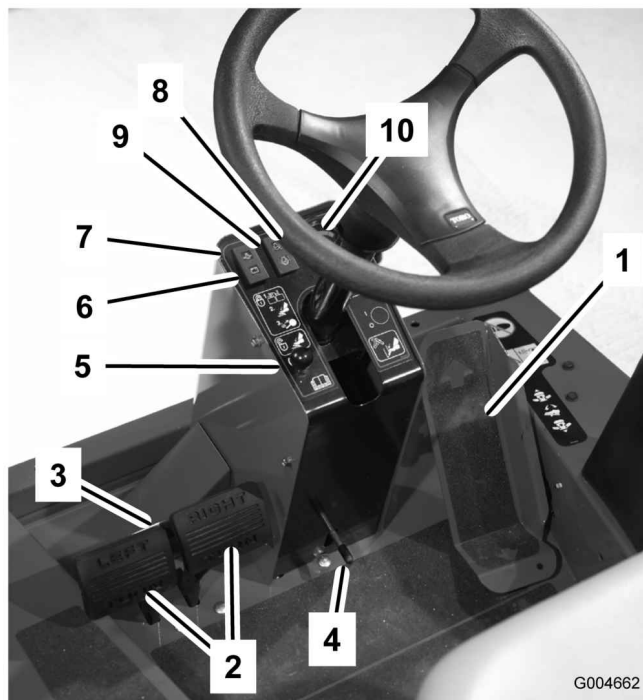

**Figure 2**

- |                        |   |
|------------------------|---|
| 1. Traction pedal      | 6. Charge indicator                         |
| 2. Brake pedals        | 7. Engine oil pressure warning light        |
| 3. Pedal locking latch | 8. Engine coolant temperature warning light |
| 4. Tilt steering lever | 9. Glow plug indicator light                |
| 5. Parking brake latch | 10. Temperature gauge                       |

## Controls

**Note:** Determine the left and right sides of the machine from the normal operating position.



This machine produces sound levels in excess of 85 dBA at the operators ear and can cause hearing loss through extended periods of exposure.

Wear hearing protection when operating this machine.

### Traction Pedal

The traction pedal (Figure 2) controls forward and reverse operation. Press the top of the pedal to move forward and the bottom to move backward. Ground speed depends on how far you press the

pedal. For no load, maximum ground speed, fully press the pedal while the throttle is in Fast.

To stop, reduce your foot pressure on the traction pedal and allow it to return to the center position.

**Important:** The speed limiter screw must stop the traction pedal before the pump reaches full stroke or damage to the pump may occur.

### Brake Pedals

Two foot pedals (Figure 2) operate individual wheel brakes for turning assistance, parking, and to aid in obtaining better side hill traction. A latch connects the pedals for parking brake operation and transport.

### Pedal Locking Latch

The pedal locking latch (Figure 2) connects the pedals together to engage the parking brake.

### Tilt Steering Lever

Press the lever (Figure 2) down to tilt the steering wheel to the desired position. Then release the lever to lock the adjustment.

### Parking Brake Latch

A knob on the left side of the console actuates the parking brake lock (Figure 2). To engage the parking brake, connect the pedals with the locking latch, push down on both pedals, and pull the parking brake latch out. To release the parking brake, press both pedals until the parking brake latch retracts.

### Charge Indicator

The charge indicator (Figure 2) illuminates when the system charging circuit malfunctions.

### Engine Oil Pressure Warning Light

The light (Figure 2) illuminates when the engine oil pressure is dangerously low.

### Engine Coolant Temperature Warning Light

The light (Figure 2) illuminates and the engine shuts down when coolant reaches an excessively high temperature.

## Glow Plug Indicator Light

When lit, the glow plug indicator light (Figure 2) indicates that the glow plugs are on.

## Engine Temperature Gauge

This gauge (Figure 2) indicates the engine coolant temperature.

## Speed Limiter

Adjust the screw (Figure 3) to limit the amount the traction pedal can be depressed in the forward direction to limit speed.

**Important:** The traction pedal must contact the speed limiter before reaching the end of the pump stroke to prevent pump damage.

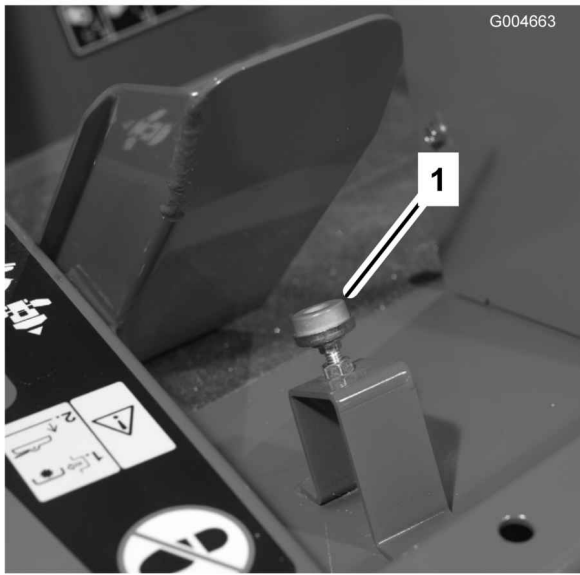

Figure 3

1. Speed limiter

## Lift Levers

The lift levers (Figure 4) raise and lower the cutting units.

**Important:** The center lift lever must momentarily be pushed to the lower position to enable PTO circuit actuation by PTO switch.

## Cutting Unit Service Lock

The cutting unit service lock (Figure 4) locks the front cutting unit lift lever when the cutting unit is in the raised position.

## Key Switch

The key switch (Figure 4) has three positions: Off, On/Preheat, and Start.

## PTO Switch

The PTO switch (Figure 4) has three positions: On (engage), Neutral, and Off (disengage). Carefully lift and push the PTO switch forward to the On position to start the implement or cutting unit blades. Slowly pull the switch backward to the Off position to stop implement operation.

**Important:** The center lift lever must momentarily be pushed to the lower position to enable PTO circuit actuation by PTO switch.

## Hi-Lo Speed Control

The control (Figure 4) allows the speed range to increase for transport of the machine.

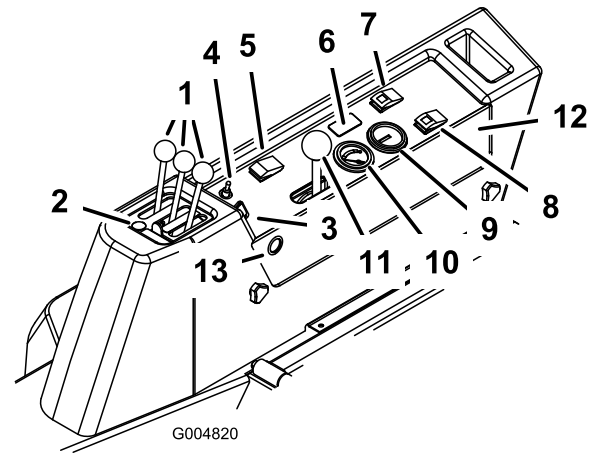

Figure 4

- |                                    |                             |
|------------------------------------|-----------------------------|
| 1. Lift lever                      | 8. Temperature reset switch |
| 2. Front cutting unit service lock | 9. Hour meter               |
| 3. Key switch                      | 10. Fuel gauge              |
| 4. PTO switch                      | 11. Throttle                |
| 5. Hi-lo speed control             | 12. Audible alarm           |
| 6. Cruise control (optional)       | 13. Power point             |
| 7. Alarm silence switch            |                             |

## Cruise Control (Optional)

The cruise control (Figure 4) sets the speed of the machine.

## Fuel Gauge

The fuel gauge (Figure 4) indicates the level of fuel in the tank.

## Hour Meter

The hour meter (Figure 4) shows the total hours that the machine has been operated.

## Temperature Override Switch

Press and hold the reset switch (Figure 4) to start the engine after high temperature shut down. Use only for emergency operation.

## Audible Alarm

The alarm (Figure 4) is activated when the low engine oil pressure light illuminates or the high coolant temperature light illuminates.

## Alarm Silence Switch

This switch (Figure 4) shuts off the audible alarm.

## Throttle Control

Move the control (Figure 4) forward to increase the engine speed and rearward to decrease the speed.

## Power Point

The power point (Figure 4) is used to power optional electrical accessories.

## Specifications

**Note:** Specifications and design are subject to change without notice.

Width of cut	
overall	124 inch (315 cm)
front cutting unit	54 inch (137 cm)
side cutting unit	37 inch (94 cm)
front and one side cutting unit	89 inch (226 cm)
Overall width	
cutting units down	127 inch (322 cm)
cutting units up (transports)	71 inch (180 cm)
Overall length	144 inch (366 cm)
Height	58 inch (147 cm)
Height with ROPS	81 inch (206 cm)
Ground clearance	6 inch (15 cm)
Wheel tread (to center of tire)	
front	45 inch (114 cm)
rear	47 inch (119 cm)
Wheel base	55-1/2 in (141 cm)
Weight (with cutting units and fluids)	3905 lb (1757 kg)

go to [www.Toro.com](http://www.Toro.com) for a list of all approved attachments and accessories.

## Attachments/Accessories

A selection of Toro approved attachments and accessories are available for use with the machine to enhance and expand its capabilities. Contact your Authorized Service Dealer or Distributor or

# Operation

**Note:** Determine the left and right sides of the machine from the normal operating position.

## Before Operating



If you leave the key in the ignition switch, someone could accidentally start the engine and seriously injure you or other bystanders.

Remove the key from the ignition before you do any maintenance.

## Checking the Engine Oil

The engine is shipped with oil in the crankcase; however, the oil level must be checked before and after the engine is first started.

The crankcase capacity is 8 qt (7.6 l) with the filter.

Use high-quality engine oil that meets the following specifications:

- API Classification Level Required: CH-4, CI-4 or higher.
- Preferred oil: SAE 15W-40 (above 0°F)
- Alternate oil: SAE 10W-30 or 5W-30 (all temperatures)

Toro Premium Engine Oil is available from your distributor in either 15W-40 or 10W-30 viscosity. See the parts catalog for part numbers.

1. Park the machine on a level surface. Unlock the engine cover latches.
2. Open the engine cover.
3. Remove the dipstick, wipe it clean, install the dipstick into the tube, and pull it out again. The oil level should be up to the FULL mark (Figure 5).

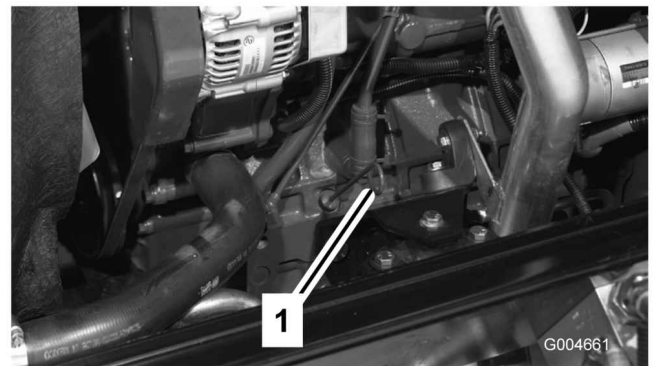

**Figure 5**

1. Dipstick

4. If the oil is below the Full mark, remove the fill cap (Figure 6) and add oil until the level reaches the Full mark. **Do not overfill.**

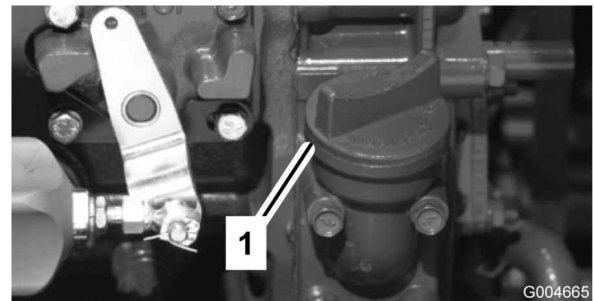

**Figure 6**

1. Oil fill cap

**Note:** When using different oil, drain all old oil from the crankcase before adding new oil.

5. Install the oil fill cap and dipstick.
6. Close the engine cover and secure it with the latches.

## Checking the Cooling System

Check level of coolant at the beginning of each day. Capacity of system is 2-3/4 gallons (10.4 l).

1. Carefully remove the radiator cap and expansion tank cap (Figure 7).



If the engine has been running, the pressurized, hot coolant can escape and cause burns.

- Do not open the radiator cap when the engine is running.
- Use a rag when opening the radiator cap, and open the cap slowly to allow steam to escape.

2. Check the coolant level in the radiator. The radiator should be filled to the top of the filler neck and the expansion tank filled to the Full mark.

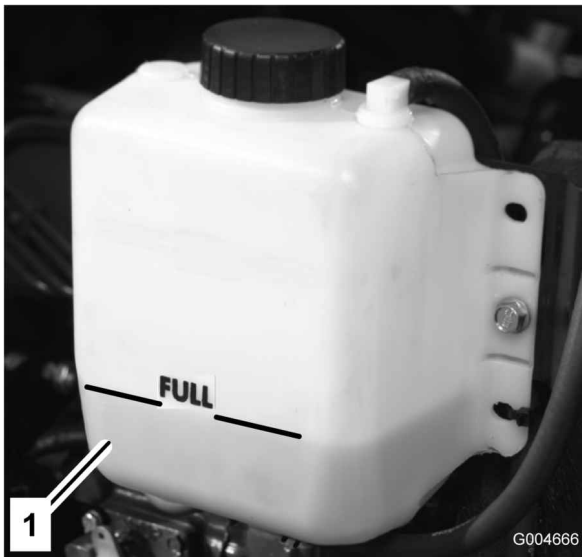

**Figure 7**

1. Expansion tank

3. If the coolant is low, add a 50/50 mixture of water and ethylene glycol anti-freeze. **Do not use water only or alcohol/methanol base coolants.**
4. Install the radiator cap and expansion tank cap.

## Filling the Fuel Tank

The capacity of the fuel tank is 19 gallons (72 l).

1. Remove the fuel tank cap (Figure 8).
2. Fill the tank to about 1 inch (25 mm) below the top of the tank, not the filler neck, with No. 2 diesel fuel. Then install the cap.



**Figure 8**

1. Fuel tank cap



Under certain conditions, diesel fuel and fuel vapors are highly flammable and explosive. A fire or explosion from fuel can burn you and others and can cause property damage.

- Use a funnel and fill the fuel tank outdoors, in an open area, when the engine is off and is cold. Wipe up any fuel that spills.
- Do not fill the fuel tank completely full. Add fuel to the fuel tank until the level is 1/4 to 1/2 inch (6 to 13 mm) below the bottom of the filler neck. This empty space in the tank allows the fuel to expand.
- Never smoke when handling fuel, and stay away from an open flame or where fuel fumes may be ignited by a spark.
- Store fuel in a clean, safety-approved container and keep the cap in place.

## Checking the Hydraulic Fluid

The machine's reservoir is filled at the factory with approximately 8 U.S. gallons (30.2 l) of high quality hydraulic fluid. **Check the level of the hydraulic fluid before the engine is first started and daily thereafter.** The recommended replacement fluid is:

### Toro Premium All Season Hydraulic Fluid

(Available in 5 gallon pails or 55 gallon drums. See parts catalog or Toro distributor for part numbers.)

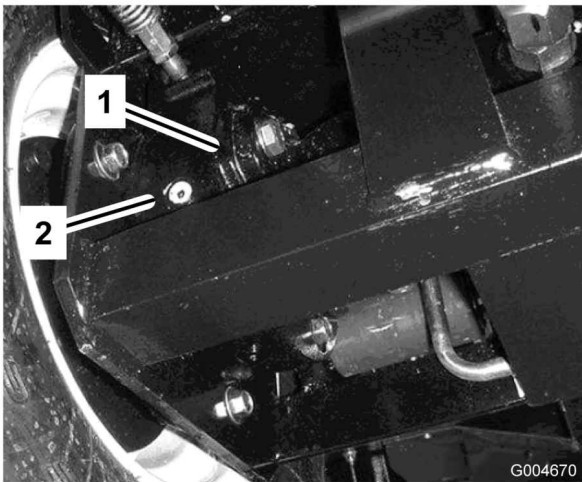



**Figure 10**

1. Check/drain plug

2. Remove the plug on the planetary (Figure 10) and check the plug on the back side of the brake (Figure 11). Oil should be at the bottom of the check plug hole on the back side of the brake.



**Figure 11**

1. Brake housing
2. Check plug

3. Add gear oil to the hole in the planetary, if necessary, to bring the oil up to the proper level. Install the plug.
4. Repeat steps 1-3 on the opposite gear assembly.

### Checking the Rear Axle Lubricant

The rear axle is shipped from the factory filled with SAE 85W-140 gear lube. Check the oil level

before the engine is first started and every 400 hours thereafter. The capacity is 80 oz (2.4 l). Visually inspect for leaks daily.

1. Position the machine on a level surface.
2. Remove a check plug from one end of the axle (Figure 12) and make sure that the lubricant is up to the bottom of the hole. If the level is low, remove the fill plug (Figure 12) and add enough lubricant to bring the level up to the bottom of the check plug holes.

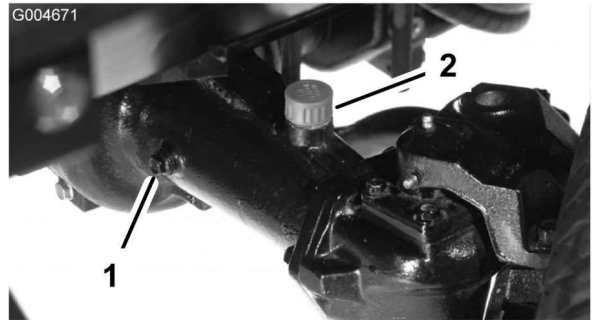

**Figure 12**

1. Check plug
2. Fill plug

### Checking the Rear Axle Gear Box Lubricant

The gear box is shipped from the factory filled with SAE 85W-140 gear lube. Check the oil level before the engine is first started and every 400 hours thereafter. The capacity is 16 oz (0.5 l). Visually inspect for leaks daily.

1. Position the machine on a level surface.
2. Remove the check/fill plug from the left side of the gear box (Figure 13) and make sure that lubricant is up to the bottom of the hole. If the level is low, add enough lubricant to bring the level up to the bottom of the hole.

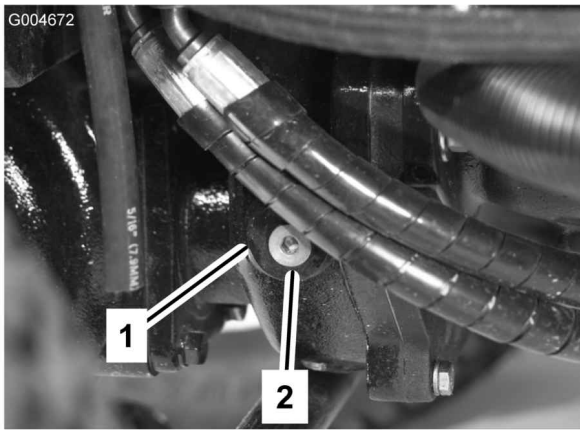

**Figure 13**

1. Gear box                      2. Check/fill plug

### Checking the Tire Pressure

The tires are over-inflated for shipping. Therefore, release some of the air to reduce the pressure. The correct air pressure in the front and rear tires is 25-30 psi (172-207 kPa).

**Important:** Maintain even pressure in all tires to ensure a good quality-of-cut and proper machine performance. Do not under-inflate.

### Checking the Torque of the Wheel Nuts or Bolts

Failure to maintain proper torque of the wheel nuts could result in failure or loss of wheel and may result in personal injury.

Torque the front wheel nuts and rear bolts to 85-100 ft-lb (115-136 N·m) after 1-4 hours of operation and again after 10 hours of operation. Torque every 200 hours thereafter.

### Adjusting the Height-of-Cut

#### Center Cutting Unit

The height-of-cut is adjustable from 1 to 5 inches (25 to 127 mm) in 1/2 inch (13 mm) increments. To adjust the height-of-cut on the front cutting unit, position the castor wheel axles in the upper or lower holes of the castor forks, add or remove an equal number of spacers from the castor forks, and secure the rear chain to the desired hole.

1. Start the engine and raise the cutting units so that the height-of-cut can be changed. Stop the engine and remove the key after the cutting unit is raised.
2. Position the castor wheel axles in the same holes in all castor forks. Refer to the following chart to determine the correct holes for the setting.

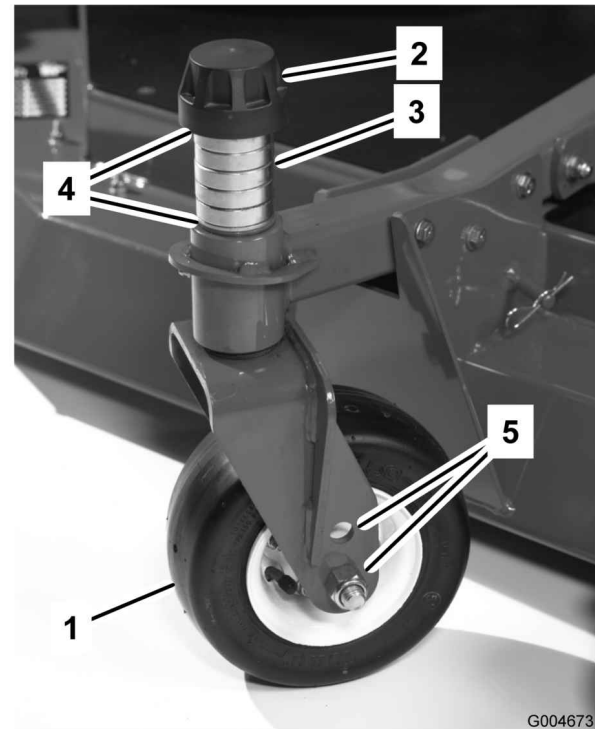

**Figure 14**

1. Castor wheel                      4. Shims  
 2. Tensioning cap                      5. Axle mounting holes  
 3. Spacers

**Note:** When operating in 2-1/2 inch (64 mm) height of cut or higher, the axle bolt must be installed in the lower castor fork hole to prevent grass buildup between the wheel and the fork. When operating in height of cuts lower than 2-1/2 inches (64 mm) and grass buildup is detected, reverse the machines direction to pull any clippings away from the wheel/fork area.

3. Remove the tensioning cap from the spindle shaft (Figure 14) and slide the spindle out of the castor arm. Put the 2 shims (1/8 inch [3 mm]) onto the spindle shaft as they were originally installed. These shims are required to achieve a level across the entire width of the cutting units. Slide the appropriate number of 1/2

inch spacers (refer to the chart below) onto the spindle shaft to get the desired height-of-cut; then slide the washer onto the shaft.

Refer to the following chart to determine the combinations of spacers for the setting:

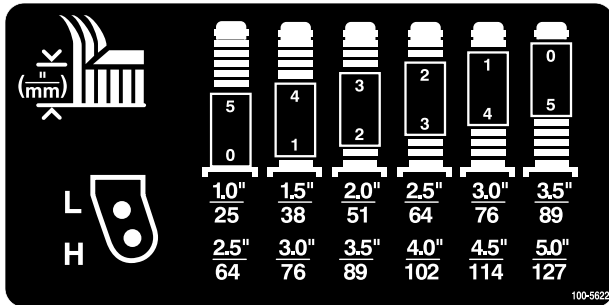

**Figure 15**

4. Push the castor spindle through the front castor arm. Install the shims (as they were originally installed) and the remaining spacers onto the spindle shaft. Install the tensioning cap to secure the assembly.
5. Remove the hairpin cotter and clevis pin securing the height-of-cut chains to the rear of the cutting unit (Figure 16).

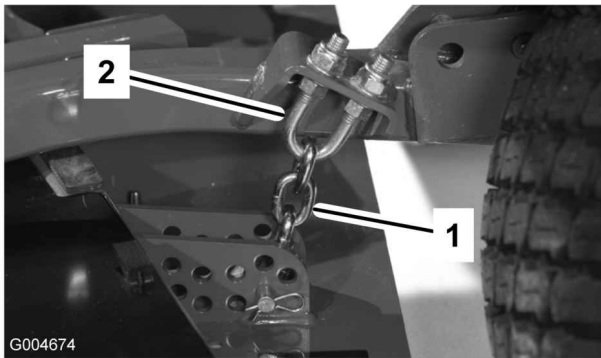

**Figure 16**

1. Height-of-cut chain
2. U-bolt

6. Mount the height-of-cut chains to the desired height-of-cut hole (Figure 17) with the clevis pin and hairpin cotter.

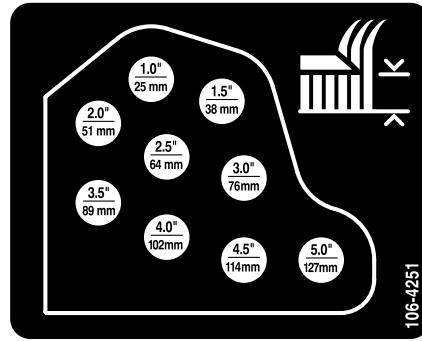

**Figure 17**

**Note:** When using 1 inch (25 mm), 1-1/2 inch (38 mm), or occasionally 2 inch (51 mm) height-of-cut, move the skids and gage wheels to the highest holes.

### Wing Cutting Units

To adjust the height-of-cut on the side cutting units, add or remove an equal number of spacers from the castor forks, position the castor wheel axles in the high or low height-of-cut holes in the castor forks, and secure the pivot arms to the selected height-of-cut bracket holes.

1. Position the castor wheel axles in the same holes in all of the castor forks (Figure 18 and Figure 20). Refer to the following chart to determine the correct hole for the setting.
2. Remove the tensioning cap from the spindle shaft (Figure 18) and slide the spindle out of castor arm. Put the two shims (1/8 inch [3 mm]) onto spindle shaft as they were originally installed. These shims are required to achieve a level across the entire width of the cutting units. Slide the appropriate number of 1/2 inch spacers onto the spindle shaft to get the desired height-of-cut; then slide the washer onto the shaft.

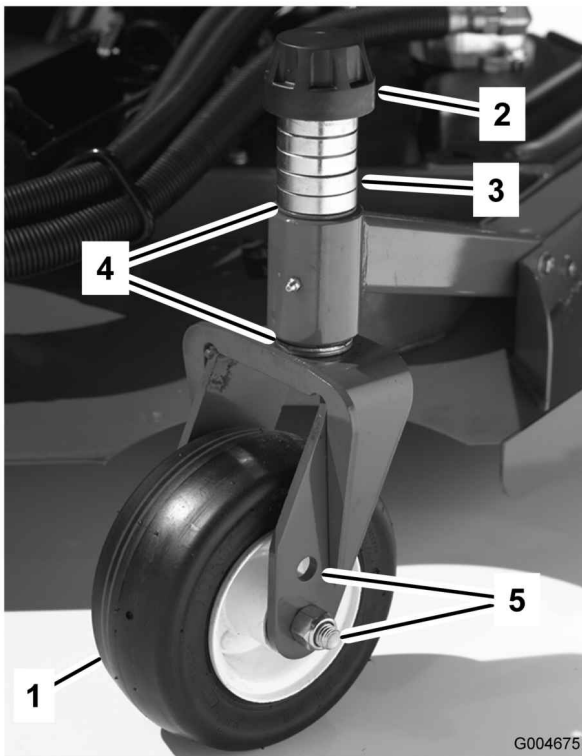

**Figure 18**

- |                   |                        |
|-------------------|------------------------|
| 1. Castor wheel   | 4. Shims               |
| 2. Tensioning cap | 5. Axle mounting holes |
| 3. Spacers        |                        |

Refer to the following chart to determine the combinations of spacers for the setting.

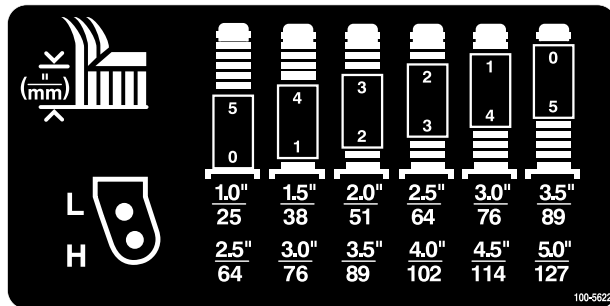
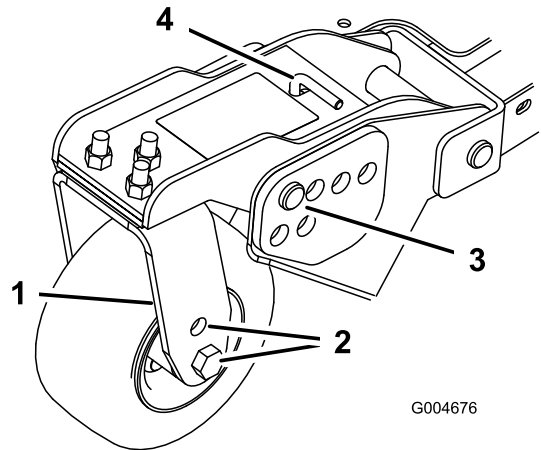

**Figure 19**

- Push the castor spindle through the castor arm. Install the shims (as originally installed) and the remaining spacers onto the spindle shaft. Install the tensioning cap to secure the assembly.
- Remove the hairpin cotter and clevis pins from the castor pivot arms (Figure 20).
- Rotate tension rod to raise or lower pivot arm until holes are aligned with selected

height-of-cut bracket holes in the cutting unit frame (Figure 20 and Figure 21).

- Insert the clevis pins and install the hairpin cotters.
- Rotate tension rod counterclockwise (finger tight) to put tension on adjustment.



**Figure 20**

- |                        |                                   |
|------------------------|-----------------------------------|
| 1. Castor pivot arm    | 3. Clevis pin and hair pin cotter |
| 2. Axle mounting holes | 4. Tension rod                    |

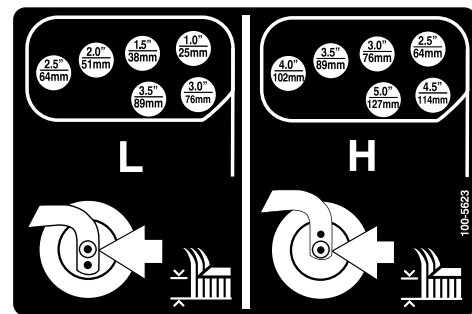
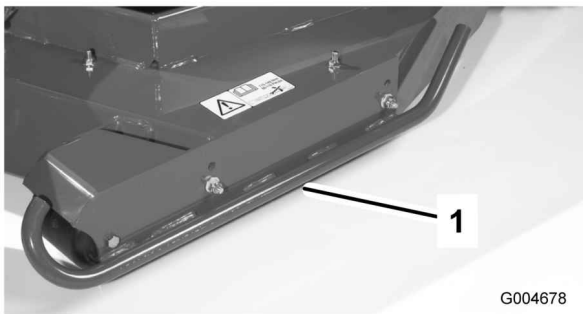

**Figure 21**

## Adjusting the Skids

The skids should be mounted in the lower position when operating in height of cuts greater than 2-1/2 inches (64 mm) and in the higher position when operating in height of cuts lower than 2-1/2 inches (64 mm).

Adjust the skids by removing the flange bolt and nuts, positioning them as desired, and installing the fasteners (Figure 22).



**Figure 22**

1. Skid

## Adjusting the Cutting Unit Rollers

The cutting unit rollers should be mounted in the lower position when operating in height of cuts greater than 2-1/2 inches (64 mm) and in the higher position when operating in height of cuts lower than 2-1/2 inches (64 mm).

1. Remove the bolt and nut securing the gage wheel to the cutting unit brackets (Figure 23).



**Figure 23**

1. Gage wheel

2. Align the roller and spacer with the top holes in the brackets and secure them with the bolt and nut.

## Adjusting the Blade

To ensure proper operation of the cutting unit, there must be 0.38-0.62 inch (10-16 mm) clearance between the tips of the wing and center cutting unit blades (Figure 24).

1. Raise cutting unit so blades are visible and block center deck section so it cannot fall accidentally. Wing decks must be horizontal to center cutting unit.

2. Rotate a center and adjoining wing blade so there blade tips are aligned. Measure distance between blade tips, distance should be approximately 0.38-0.62 inch (10-16 mm) (Figure 24).

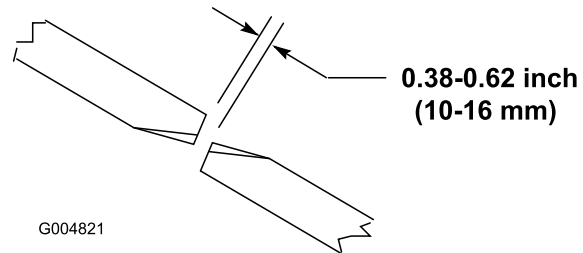

**Figure 24**

3. To adjust distance, locate adjuster bolt on rear pivot link of cutting unit (Figure 25). Loosen jam nut on adjuster bolt. Loosen or tighten adjuster bolts until 0.38-0.62 inch (10-16 mm) clearance is attained, then tighten jam nut.
4. Repeat procedure on opposite side of cutting deck.

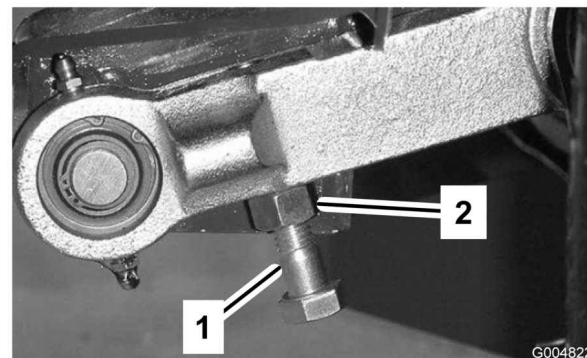

**Figure 25**

1. Adjuster bolt
2. Jam nut

## Correcting Mismatch Between Cutting Units

Due to differences in grass conditions and the counterbalance setting of the traction unit, it is advised that grass be cut and appearance checked before formal cutting is started.

1. Set all cutting units to the desired height of cut; refer to Adjusting the Height of Cut table in Specifications, page 18.
2. Check and adjust front and rear tractor tire pressure to 25-30 psi (172-207 kPa).

3. Check and adjust all castor tire pressures to 50 psi (345 kPa).
4. Check charge and counterbalance pressures with engine at high idle using test ports defined in Hydraulic Systems Test Ports. Adjust counterbalance setting to be 230 psi (1585 kPa) higher than charge pressure reading.
5. Check for bent blades; refer to Checking for a Bent Blade procedure in Mower Maintenance, page 51.
6. Cut grass in a test area to determine if all cutting units are cutting at the same height.
7. If cutting unit adjustments are still needed, find a flat surface using a 6 foot (2 m) or longer straight edge.
8. To ease measuring blade plane, raise the height of cut to the highest position; refer to Adjusting the Height of Cut.
9. Lower cutting units onto the flat surface. Remove the covers from the top of the cutting units.
10. Loosen the flange nut, securing the idler pulley, to release the belt tension on each cutting unit.

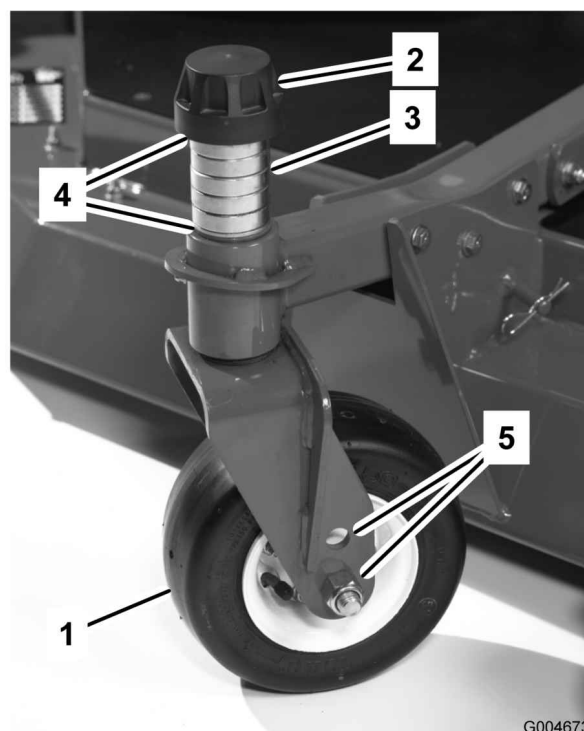

**Figure 26**

- |                   |                        |
|-------------------|------------------------|
| 1. Castor wheel   | 4. Shims               |
| 2. Tensioning cap | 5. Axle mounting holes |
| 3. Spacers        |                        |

### Center Cutting Unit Setup

Rotate blade on each spindle until the ends face forward and backward. Measure from the floor to the front tip of the cutting edge. Adjust 1/8 inch shims on front castor fork(s) to match height of cut to decal (Figure 26); refer to Adjusting the Cutting Unit Pitch procedure in Mower Maintenance, page 51.

### Wing Cutting Unit Setup

Rotate blade of each spindle until the ends face forward and backward. Measure from the floor to the front tip of the cutting edge. Adjust 1/8 inch shims on front castor arm(s) to match height of cut to decal (Figure 27). For the outside blade spindle only, refer to Adjusting the Cutting Unit Pitch procedure in Mower Maintenance, page 51.

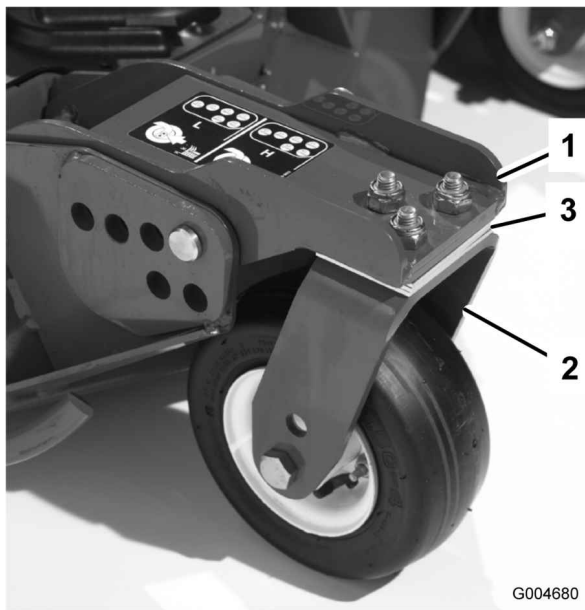

**Figure 27**

1. Front castor arm

### Matching Height Of Cut Between Cutting Units

1. Position blade side to side on outside spindle of both wing cutting units. Measure from the floor to the tip of the cutting edge on both units and compare. These numbers should be within 1/8 inch (3 mm) of each other.
2. Add or remove 1/8 inch shims as needed on wing castor wheels. Recheck measurement between outside edges of both wing cutting units and adjust as necessary.

## Starting and Stopping the Engine

**Important:** The fuel system will automatically bleed itself when any of the following situations occur:

- Initial start up of a new machine.
- The engine has ceased running due to lack of fuel.
- Maintenance has been performed upon the fuel system components.

Refer to the Bleeding Air from the Injectors procedure in Fuel System Maintenance, page 40.

1. Ensure that the parking brake is set. Remove your foot from the traction pedal and ensure that it is in neutral.

2. Move the throttle control to the mid-idle position.
3. Turn the ignition key to the Run position. The glow indicator will light.
4. When the glow indicator dims, turn the ignition key to the Start position. Release the key immediately when the engine starts and allow it to return to the Run position. Allow engine to warm up at mid speed (without load), then move the throttle control to the desired position.

**Important:** Do not run the starter motor more than 15 seconds at a time or premature starter failure may result. If the engine fails to start after 15 seconds, turn the key to the Off position, recheck the controls and procedures, wait 15 additional seconds, and repeat the starting procedure.

When the temperature is less than 20°F (-75C), preheat glow plugs twice prior to initial cranking attempt. The starter motor can be run for 30 seconds on then 60 seconds off for 2 attempts.

5. When the engine is started for the first time, or after an overhaul of the engine, transmission, or axle, operate the machine in forward and reverse for one or two minutes. Also operate the lift lever and PTO lever to ensure proper operation of all parts. Turn the steering wheel to the left and right to check steering response. Then shut the engine off and check for oil leaks, loose parts, and any other noticeable difficulties.



**Shut the engine off and wait for all moving parts to stop before checking for oil leaks, loose parts, and other malfunctions.**

6. To stop the engine, move the throttle control backward to the Slow position, move the PTO lever to the Off position, set the parking brake, and rotate the ignition key to Off. Remove the key from the switch to prevent accidental starting.

**Important:** Allow engine to idle for 5 minutes before shutting it off after a full load operation. Failure to do so may lead to turbo-charger trouble.

## Checking the Interlock Switches



If safety interlock switches are disconnected or damaged the machine could operate unexpectedly causing personal injury.

- Do not tamper with the interlock switches.
- Check the operation of the interlock switches daily and replace any damaged switches before operating the machine.
- Replace switches every two years or 1500 hours, whichever occurs first, regardless of whether they are operating properly or not.

The machine has interlock switches in the electrical system. These switches are designed to stop the engine when operator gets off of the seat when the traction pedal is depressed. However, the operator may get off of the seat while the engine is running and the traction pedal is in neutral. Although the engine will continue to run if the PTO lever is disengaged and the traction pedal is released, it is strongly recommended that the engine be stopped before rising from the seat.

To check the operation of the interlock switches, perform the following procedure:

1. Drive the machine slowly to a large, relatively open area. Lower the cutting unit, stop the engine, and apply the parking brake.
2. Sit on the seat and depress the traction pedal. Try to start the engine. The engine should not crank. If the engine cranks, there is a malfunction in the interlock system that should be corrected before beginning operation.
3. Sit on the seat and start the engine. Rise from the seat and move the PTO lever to On. The PTO should not engage. If the PTO engages, there is a malfunction in the interlock system that should be corrected before beginning operation.

4. Sit on the seat, engage the parking brake and start the engine. Move the traction pedal out of the neutral position. The engine should kill. If the engine does not kill, there is a malfunction in the interlock system that should be corrected before beginning operation.
5. Sit on the seat, start the engine and set speed range to low. Move PTO switch forward to engage cutting units.

**Important:** The center lift lever must momentarily be pushed to the lower position to enable PTO circuit actuation by PTO switch.

- Raise either wing cutting unit to the transport position. The cutting unit should turn off. If the cutting unit does not stop, there is a malfunction in the interlock system that should be corrected before resuming operation.
- If the cutting unit is lowered again the motor should re-start. If the cutting unit does not re-start, there is a malfunction in the interlock system that should be corrected before resuming operation.
- Raise the center cutting unit to the transport position. All the cutting units should stop running and not re-engage when lowered to the ground. If the cutting unit does not stop when it is raised or if it re-starts when it is lowered, there is a malfunction in the interlock system that should be corrected before resuming operation.
- With the cutting units engaged, switch the speed range from low to high. The cutting units should stop. If the cutting units do not stop, there is a malfunction in the interlock system that should be corrected before resuming operation.
- If the operator rises from the seat with the cutting units engaged and/or the traction pedal out of neutral, the cutting units must stop in approximately one second and engine must shutdown in approximately two seconds. If the cutting units do not stop and the engine does not shutdown, there is a malfunction in the interlock system that should be corrected before resuming operation.

## Pushing or Towing the Machine

In an emergency, the machine can be moved forward by actuating the bypass valve in the variable displacement hydraulic pump and pushing or towing the machine. **Do not push or tow the machine for more than 1/4 mile (0.4 km).**

**Important:** Do not push or tow the machine faster than 2-3 MPH (3-4.8 km/h) because internal transmission damage may occur. The bypass valve must be open whenever the machine is pushed or towed.

1. Raise the seat and remove the battery cover. The bypass valve is located in front of the battery (Figure 28).
2. Rotate the valve 90° in either direction to open and allow oil to bypass internally. Because fluid is bypassed, the machine can be slowly moved without damaging the transmission.

**Note:** Resistance will be felt on the valve when it is moved to the open position.

3. Close the bypass valve before starting the engine. However, do not exceed 5 to 8 ft-lb (7 to 11 N·m) torque to close the valve.

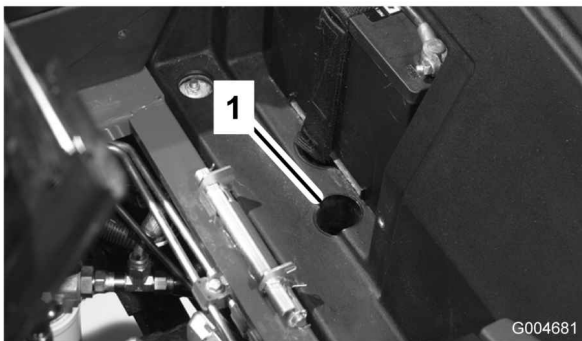

**Figure 28**

1. Bypass valve access hole

**Important:** If the machine must be pushed or towed in reverse, the check valve in the four-wheel drive manifold must also be bypassed. To bypass the check valve, connect a hose assembly (Hose Part No. 95-8843, Coupler Fitting No. 95-0985 [Qty. 2], and Hydraulic Fitting No. 340-77 [Qty. 2]) to the reverse traction pressure test port (Figure 29) and the reverse four-wheel drive pressure port (Figure 30).

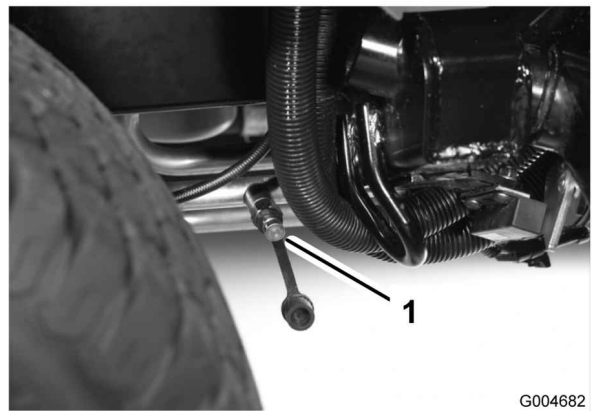

**Figure 29**

1. Reverse traction pressure test port

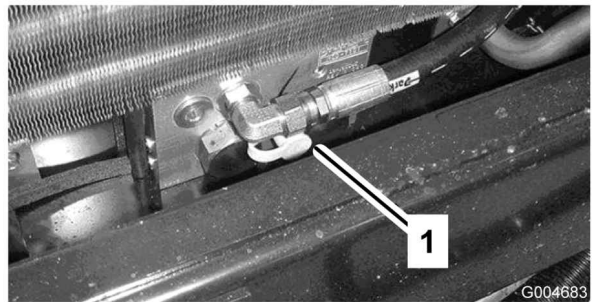

**Figure 30**

1. Reverse four-wheel drive pressure test port

## Jacking Points

- On the front of the machine on the frame on the inside of each drive tire
- On the rear of the machine at the center of the axle

## Tie Downs

- On each side of the frame by the side cutting unit lift arms
- Front center of the operator's platform
- The rear bumper

## Operating Characteristics

Practice driving the machine because it has a hydrostatic transmission and its characteristics are different than many turf maintenance machines. Some points to consider when operating the traction unit, cutting unit, or other implements are

the transmission, engine speed, load on the cutting blades or other implement components, and the importance of the brakes.

To maintain enough power for the traction unit and implement while operating, regulate the traction pedal to keep the engine RPM high and somewhat constant. A good rule to follow is to decrease the ground speed as the load on the implement increases, and increase the ground speed as the load decreases.

Therefore, allow the traction pedal to move backward as the engine RPM decreases, and depress the pedal slowly as the RPM increases. By comparison, when driving from one work area to another, with no load and cutting unit raised, have the throttle in the Fast position and depress the traction pedal slowly but fully to attain maximum ground speed.

The flow divider enhances traction drive performance in compromised operating conditions. The flow divider is for use in low speed range only. When approaching an area known to cause wheel spin, depress and hold flow divider switch until completely past the area. If a tire spins while climbing or maneuvering on slopes, depress switch and slowly drive out of area. If both a front and rear wheel spins, the steering brake can be feathered to transfer the torque from the spinning wheels to opposite front wheel.

Another characteristic to consider is the operation of the pedals that are connected to the brakes. The brakes can be used to assist in turning the machine. However, use them carefully, especially on soft or wet grass because the turf may be torn accidentally. Another benefit of the brakes is to maintain traction. For example, in some slope conditions, the uphill wheel slips and loses traction. If this situation occurs, depress the uphill turn pedal gradually and intermittently until the uphill wheel stops slipping, thus, increasing traction on the downhill wheel.

Use extra care when operating the machine on slopes. Make sure that the seat latch is properly secured and the seat belt is buckled. Drive slowly and avoid sharp turns on slopes to prevent roll overs. For steering control, the cutting unit must be lowered when going downhill.



**This product is designed to drive objects into the ground where they lose energy quickly in grass areas. However, careless operation, combined with terrain angle, ricochets, or improperly positioned safety guard can lead to thrown object injuries.**

- **When a person or pet appears suddenly in or near the mowing area, stop mowing.**
- **Do not resume mowing until the area is cleared.**

Before stopping the engine, disengage all controls and move the throttle to Slow. Moving the throttle to Slow reduces high engine RPM, noise, and vibration. Turn the key to Off to stop the engine.

Before transporting the machine, raise the cutting units and secure the transport latches (Figure 31).

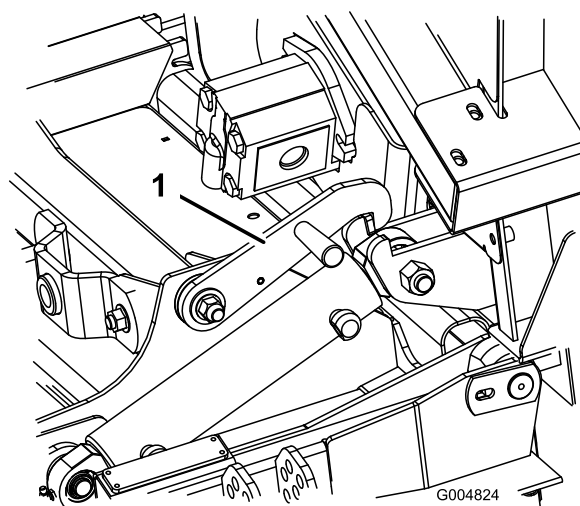

**Figure 31**

1. Transport latch (wing cutting units)

## Operating Tips

### Mow When Grass is Dry

Mow either in the late morning to avoid the dew, which causes grass clumping, or in late afternoon to avoid the damage that can be caused by direct sunlight on the sensitive, freshly mowed grass.

## Select the Proper Height-of-Cut Setting to Suit Conditions

Remove approximately 1 inch (25 mm) or no more than 1/3 of the grass blade when cutting. In exceptionally lush and dense grass, you may have to raise the height-of-cut to the next setting.

## Mow at Proper Intervals

Under most normal conditions you will need to mow approximately every 4-5 days. But remember, grass grows at different rates at different times. This means that in order to maintain the same height-of-cut, which is a good practice, you will need to cut more frequently in early spring; as the grass growth rate slows in mid summer, cut only every 8-10 days. If you are unable to mow for an extended period due to weather conditions or other reasons, mow first with the height-of-cut at a high level; then mow again 2-3 days later with a lower height setting.

## Always Mow with Sharp Blades

A sharp blade cuts cleanly and without tearing or shredding the grass blades like a dull blade. Tearing and shredding causes the grass to turn brown at the edges which impairs growth and increases susceptibility to diseases.

## Transporting

Use the transport latches when transporting over long distances, rough terrain, or when trailering.

## After Operating

To ensure optimum performance, clean the underside of the mower housing after each use. If residue is allowed to build up in the mower housing, cutting performance will decrease.

Also, remove any debris which may have collected between the deck lift cylinders and the foam deck pads (Figure 32).

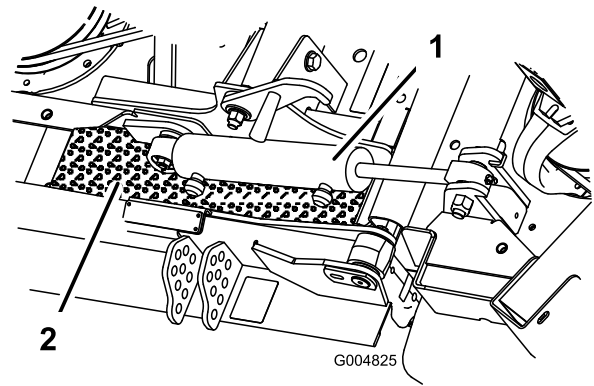

**Figure 32**

1. Deck lift cylinder      2. Foam deck pad

## Cutting Unit Pitch

We recommend a blade pitch of 1/4 inch (6 mm). A pitch larger than 1/4 inch (6 mm) will result in less power required, larger clippings, and a poorer quality of cut. A pitch less than 1/4 inch (6 mm) will result in more power required, smaller clippings and a better quality of cut.

# Maintenance

**Note:** Determine the left and right sides of the machine from the normal operating position.

## ***Recommended Maintenance Schedule(s)***

<b>Maintenance Service Interval</b>	<b>Maintenance Procedure</b>
After the first 10 operating hours	<ul style="list-style-type: none"> <li>• Torque the wheel lug nuts.</li> <li>• Check the fan and alternator belt tension.</li> <li>• Check the blade drive belt tension.</li> </ul>
After the first 50 operating hours	<ul style="list-style-type: none"> <li>• Change the engine oil and filter.</li> <li>• Check the engine RPM (at idle and full throttle).</li> <li>• Torque the locknuts on the pivots.</li> </ul>
After the first 200 operating hours	<ul style="list-style-type: none"> <li>• Change the front planetary gear oil.</li> <li>• Change the rear axle oil.</li> <li>• Change the hydraulic oil.</li> <li>• Change the hydraulic oil filters.</li> </ul>
Before each use or daily	<ul style="list-style-type: none"> <li>• Check the engine oil level.</li> <li>• Check the coolant level.</li> <li>• Check the hydraulic fluid level.</li> <li>• Check the tire pressure.</li> </ul>
Every 50 hours	<ul style="list-style-type: none"> <li>• Lubricate all grease fittings.</li> <li>• Inspect the air cleaner.</li> <li>• Check the battery level and cable connections.</li> <li>• Check the blade drive belt tension.</li> <li>• Clean the underside of the mower housing and under the belt covers.</li> </ul>
Every 100 hours	<ul style="list-style-type: none"> <li>• Inspect the cooling system hoses.</li> <li>• Check the fan and alternator belt tension.</li> </ul>
Every 150 hours	<ul style="list-style-type: none"> <li>• Change the engine oil and filter.</li> </ul>
Every 200 hours	<ul style="list-style-type: none"> <li>• Torque the wheel lug nuts.</li> <li>• Service the spark arrestor.</li> </ul>
Every 400 hours	<ul style="list-style-type: none"> <li>• Check the planetary gear drive oil.</li> <li>• Check the rear axle lubricant.</li> <li>• Check the rear axle gear box lubricant.</li> <li>• Service the air filter (if the indicator shows red).</li> <li>• Inspect the fuel lines and connections.</li> <li>• Change the fuel filters (fuel/water and prefilter).</li> <li>• Check the engine RPM (at idle and full throttle).</li> </ul>
Every 800 hours	<ul style="list-style-type: none"> <li>• Drain and clean the fuel tank.</li> <li>• Change the front planetary gear oil.</li> <li>• Change the rear axle oil.</li> <li>• Check the rear wheel toe-in.</li> <li>• Inspect the blade drive belts.</li> <li>• Change the hydraulic oil.</li> <li>• Change the hydraulic oil filters.</li> <li>• Inspect the cutting unit castor wheel assemblies.</li> <li>• Check and adjust the valve clearance.</li> </ul>
Every 2 years	<ul style="list-style-type: none"> <li>• Replace the safety switches.</li> <li>• Flush the cooling system and replace fluid.</li> <li>• Replace moving hoses.</li> </ul>



If you leave the key in the ignition switch, someone could accidentally start the engine and seriously injure you or other bystanders.

Remove the key from the ignition before you do any maintenance.

## Premaintenance Procedures

### Service Interval Chart

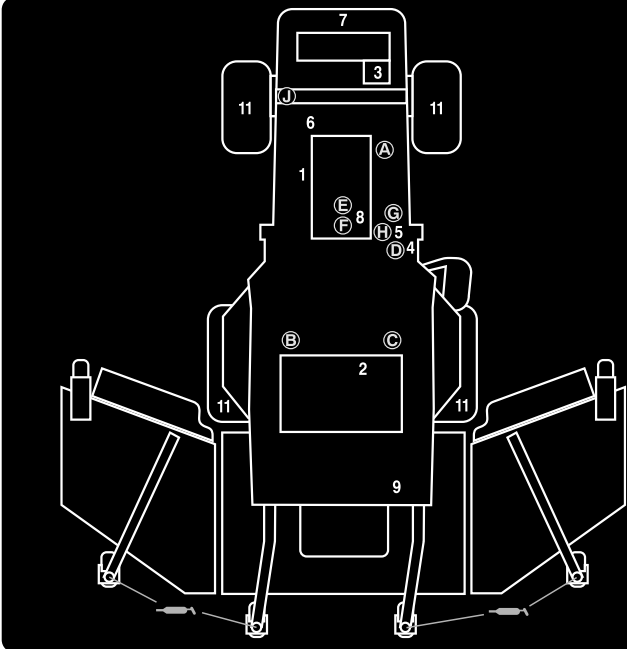

#### GROUNDMASTER 4100 QUICK REFERENCE AID

**CHECK/SERVICE (DAILY)**

<ul style="list-style-type: none"> <li>1. ENGINE OIL LEVEL</li> <li>2. HYDRAULIC FLUID LEVEL</li> <li>3. ENGINE COOLANT LEVEL</li> <li>4. FUEL - DIESEL ONLY</li> <li>5. FUEL/WATER SEPARATOR</li> <li>6. FAN BELT TENSION</li> <li>7. RADIATOR SCREEN</li> </ul>	<ul style="list-style-type: none"> <li>8. AIR CLEANER</li> <li>9. BRAKE FUNCTION</li> <li>10. INTERLOCK SYSTEM</li> <li>11. TIRE PRESSURE - 25 PSI / 1.70 BAR</li> <li>12. GREASE POINTS (4)</li> </ul> <p>SEE OPERATOR'S MANUAL FOR 50 HR INTERVAL GREASE POINTS.</p>
---	--

**SPECIFICATIONS/CHANGE INTERVALS**

SEE OPERATOR'S MANUAL FOR INITIAL CHANGES.	FLUID TYPE	CAPACITY	CHANGE INTERVAL		FILTER PART NO.	
			FLUID	FILTER		
ENGINE OIL	10W-30 CE	8 QUARTS	100 HOURS	100 HOURS	98-7431(A)	
HYDRAULIC FLUID	ISO VG 46/68	8 GALLONS	800 HOURS	800 HOURS	75-1310(B) 94-2621(C)	
HYDRAULIC BREATHER				800 HRS/YRLY	68-6150(D)	
INTERLOCK SWITCHES			2 YEARS			
PRIMARY AIR FILTER					SEE SERVICE INDICATOR 104-4260(E)	
SAFETY AIR FILTER					SEE OPERATOR'S MANUAL 104-4261(F)	
FUEL SYSTEM	> 32 F	NO. 2 DIESEL	19 GALLONS	800 HOURS	400 HOURS/ YEARLY	98-9764(G) FUEL SEPARATOR
	< 32 F	NO. 1 DIESEL		DRAIN/FLUSH		
REAR AXLE	85W-140	80 OUNCES	800 HOURS		99-7591 99-2389(J)	
PLANETARY DRIVE	85W-140	16 OUNCES	800 HOURS			
ENGINE COOLANT	50% WATER 50% ETHYL GLYCOL	11 QUARTS	DRAIN & FLUSH EVERY 2 YRS.			

Figure 33

## Lubrication

### Greasing the Bearings and Bushings

The machine has grease fittings that must be lubricated regularly with No. 2 General Purpose Lithium Base Grease. If the machine is operated under normal conditions, lubricate all bearings and bushings after every 50 hours of operation or immediately after every washing.

Bearings rarely fail from defects in materials or workmanship. The most common reason for failure is moisture and contamination working its way past the protective seals. Bearings that

are greased will rely upon regular maintenance to purge harmful debris from the bearing area. Sealed bearings, such as the castor wheel bearings, rely on an initial fill of special grease and a robust integral seal to keep contaminants and moisture out of the rolling elements.

The sealed bearings require no lubrication or short term maintenance. This minimizes routine service required and reduces the potential of turf damage due to grease contamination. These sealed bearing packages will provide good performance and life under normal use, but periodic inspections of bearing condition and seal integrity should be conducted to avoid downtime. These bearings should be inspected seasonally and replaced

if damaged or worn. Bearings should operate smoothly with no detrimental characteristics such as high heat, noise, looseness or indications of corrosion (rust).

Due to the operating conditions these bearing/seal packages are subject to (i.e. sand, turf chemicals, water, impacts, etc.) they are considered normal wear items. Bearings that fail due to causes other than defects in materials or workmanship are typically not covered under warranty.

**Note:** Bearing life can be negatively affected by improper wash down procedures. Do not wash down the unit when it is still hot and avoid directing high-pressure or high volume spray at the bearings.

The grease fitting locations and quantities are:

### Traction Unit

- Brake shaft pivot bearings (5) (Figure 34)
- Traction pedal pivot bushing (1) (Figure 35)
- Front and rear axle pivot bushings (2) (Figure 36)
- Steering cylinder ball joints (2) (Figure 37)
- Tie rod ball joints (2) (Figure 37)
- King pin bushings (2) (Figure 37).  
**The top fitting on the king pin should only be lubricated annually (2 pumps).**

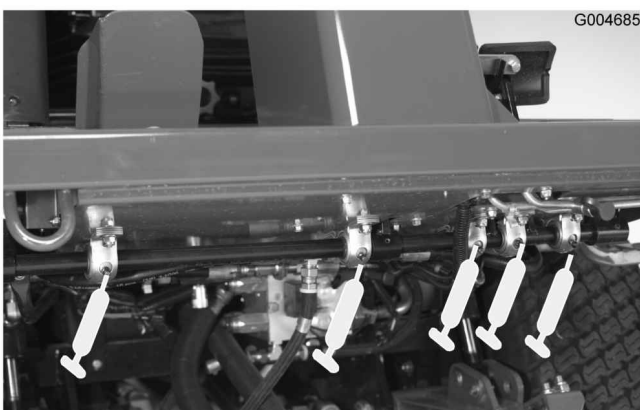

**Figure 34**

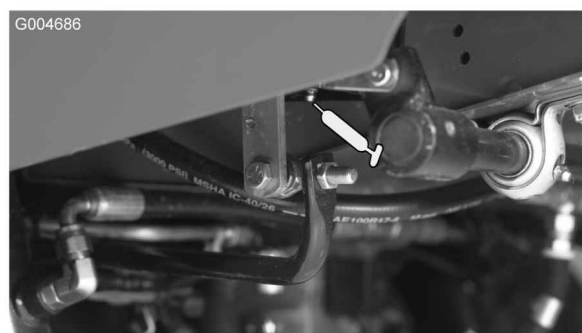

**Figure 35**

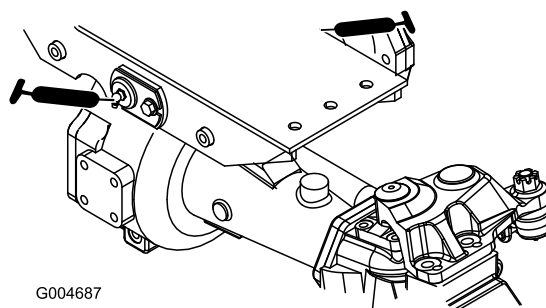

**Figure 36**



**Figure 37**

### Center Cutting Unit

- Upper link pivot (4) (Figure 38)

- Lower link pivot (2) (Figure 38)
- Latch pivot (2) (Figure 38)

**Note:** Deck may have to be raised to expose the grease fittings for the lower link pivot and the latch pivot.

- Castor fork shaft bushings (2) (Figure 39)
- Spindle shaft bearings (3) (Figure 40)
- Idler arm pivot bushings (2) (Figure 40)

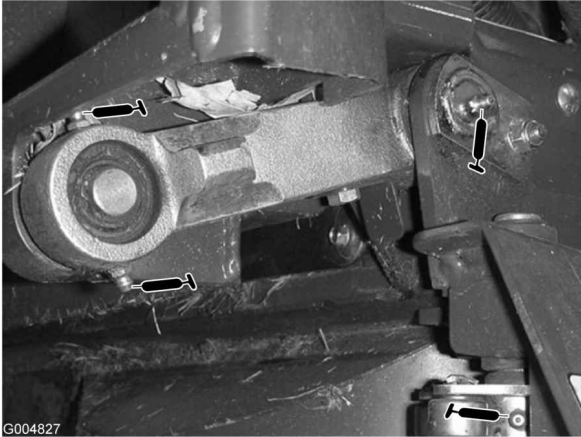

**Figure 38**



**Figure 39**

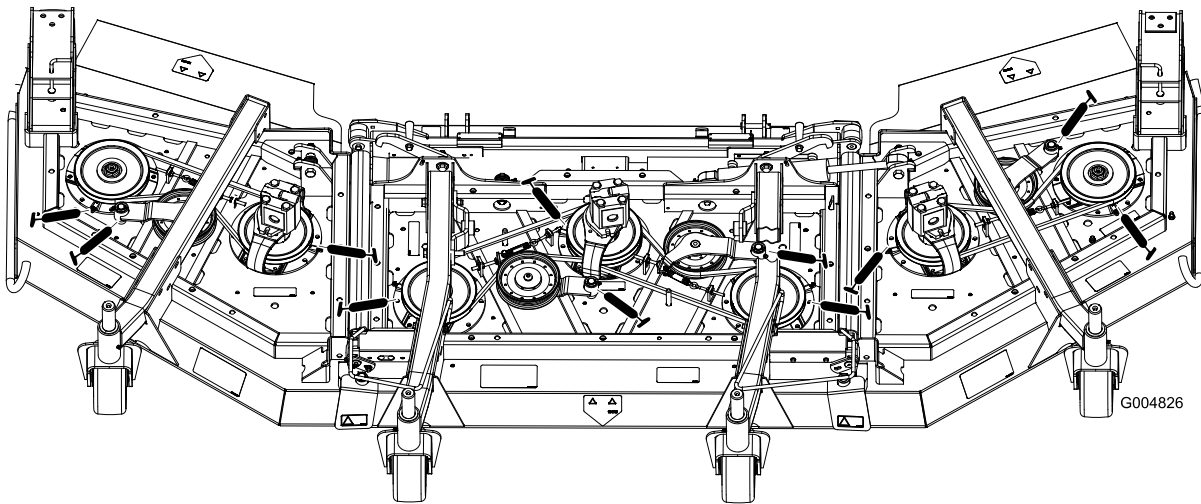

**Figure 40**

### Center Lift Assemblies

- Lift arm bushings (2) (Figure 41)
- Lift cylinder bushings (4) (Figure 41)
- Lift arm ball joints (2) (Figure 42)



**Figure 41**

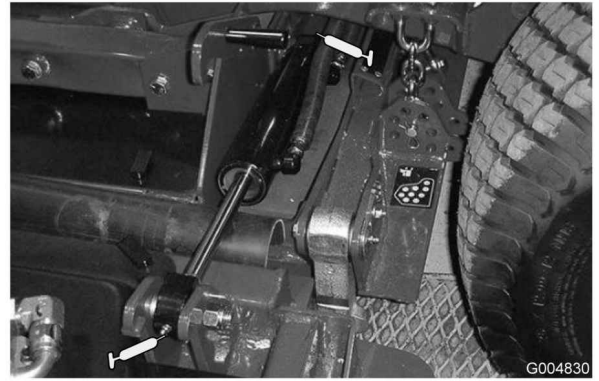
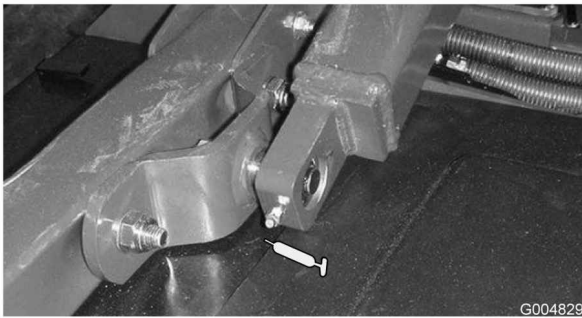

**Figure 43**

---

### Wing Cutting Units

- Castor fork shaft bushing (1 each) (Figure 44)
- Spindle shaft bearings (4)
- Idler arm pivot bushings (1) (located on the idler arm)



**Figure 42**

---

### Wing Lift Assemblies

Wing lift cylinder (4) (Figure 43)



**Figure 44**

# Engine Maintenance

## Air Cleaner Maintenance

- Check the air cleaner body for damage which could cause an air leak. Replace if damaged. Check the whole intake system for leaks, damage or loose hose clamps.
- Service the air cleaner filter only when the service indicator requires it or every 400 hours (more frequently in extremely dusty or dirty conditions). Changing the air filter before it is necessary only increases the chance of dirt entering the engine when the filter is removed.
- Be sure the cover is seated correctly and seals with the air cleaner body.

### Servicing the Air Cleaner

Check the air cleaner body for damage which could possibly cause an air leak. Replace a damaged air cleaner body.

Service the air cleaner filters when the air cleaner indicator (Figure 45) shows red or every 400 hours (more frequently in extremely dusty or dirty conditions). Do not over-service the air filter.

Be sure that the cover is sealing around the air cleaner body.

1. Pull the latch outward and rotate the air cleaner cover counterclockwise. Remove the cover from the body (Figure 45). Clean the inside of the air cleaner cover.

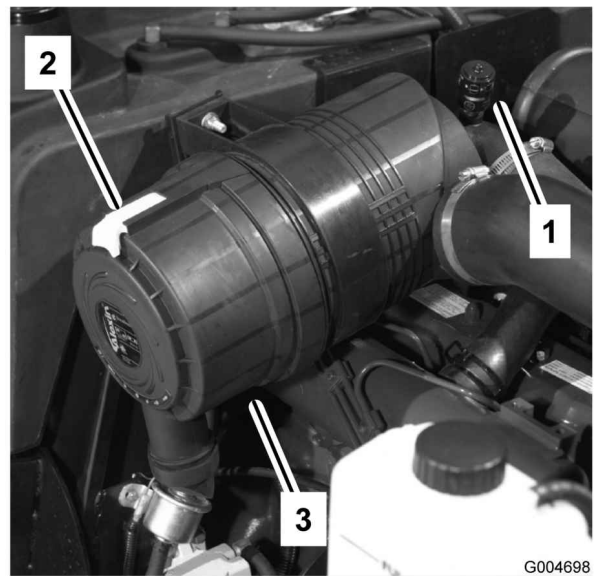

**Figure 45**

1. Air cleaner indicator
2. Air cleaner latch
3. Air cleaner cover

2. Before removing the filter (Figure 46), use low pressure air (40 psi, clean and dry) to help remove large accumulations of debris packed between outside of primary filter and the canister. Avoid using high pressure air which could force dirt through the filter into the intake tract. This cleaning process prevents debris from migrating into the intake when the primary filter is removed.

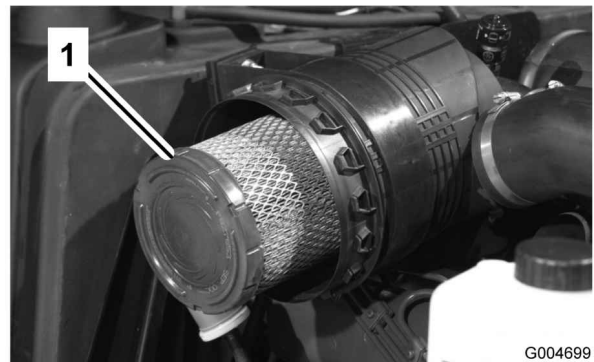
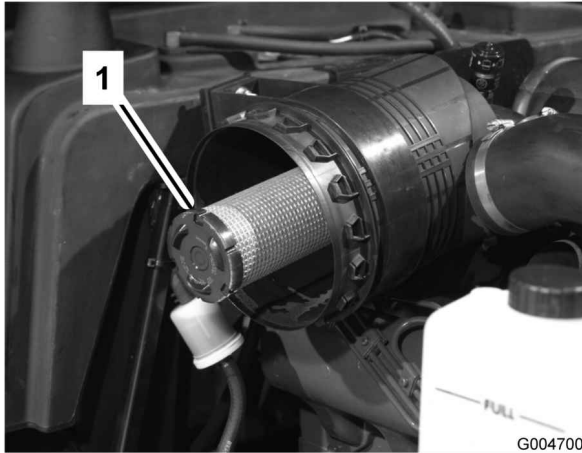

**Figure 46**

1. Air cleaner primary filter
3. Remove and replace the primary filter. Cleaning of the used element is not recommended due to the possibility of damage to the filter media. Inspect the new filter for shipping damage, checking the sealing end of the filter and the body. Do not use a damaged element. Insert

the new filter by applying pressure to the outer rim of the element to seat it in the canister. Do not apply pressure to the flexible center of the filter.

**Important:** Never attempt to clean the safety filter (Figure 47). Replace the safety filter with a new one after every three primary filter services.



**Figure 47**

1. Air cleaner safety filter

- 
4. Clean the dirt ejection port located in the removable cover. Remove the rubber outlet valve from the cover, clean the cavity and replace the outlet valve.
  5. Install the cover orienting the rubber outlet valve in a downward position - between approximately 5:00 to 7:00 when viewed from the end.
  6. Reset the indicator (Figure 45) if it shows red.

## Servicing the Engine Oil and Filter

Change the oil and filter initially after the first 50 hours of operation; thereafter change the oil and filter every 150 hours.

1. Remove either drain plug (Figure 48) and let the oil flow into a drain pan. When the oil stops, install the drain plug.

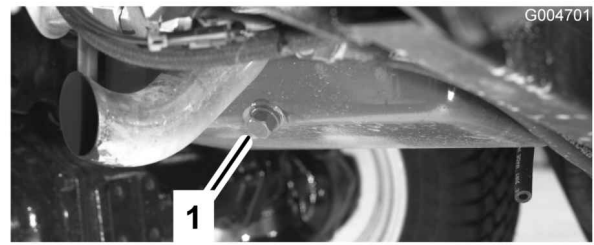

**Figure 48**

1. Engine oil drain plug

- 
2. Remove the oil filter (Figure 49). Apply a light coat of clean oil to the new filter seal before screwing it on. **Do not overtighten.**

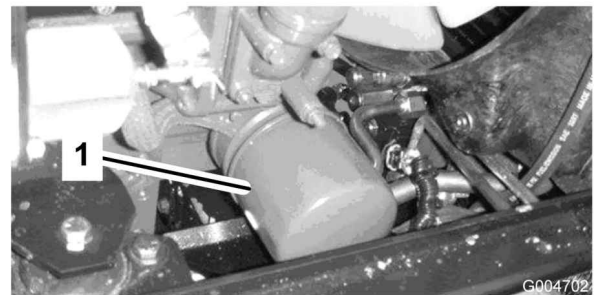

**Figure 49**

1. Engine oil filter

- 
3. Add oil to the crankcase; refer to Checking the Engine Oil.

# Fuel System Maintenance

## Servicing the Fuel System



Under certain conditions, diesel fuel and fuel vapors are highly flammable and explosive. A fire or explosion from fuel can burn you and others and can cause property damage.

- Use a funnel and fill the fuel tank outdoors, in an open area, when the engine is off and is cold. Wipe up any fuel that spills.
- Do not fill the fuel tank completely full. Add fuel to the fuel tank until the level is 1/4 to 1/2 inch (6 to 13 mm) below the bottom of the filler neck. This empty space in the tank allows the fuel to expand.
- Never smoke when handling fuel, and stay away from an open flame or where fuel fumes may be ignited by a spark.
- Store fuel in a clean, safety-approved container and keep the cap in place.

### Fuel Tank

Drain and clean the fuel tank every 800 hours. Also, drain and clean the tank if fuel system becomes contaminated or if the machine will be stored for an extended period of time. Use clean fuel to flush out the tank.

### Fuel Lines and Connections

Check the fuel lines and connections every 400 hours or yearly, whichever comes first. Inspect them for deterioration, damage, or loose connections.

### Water Separator

Drain water or other contaminants from the water separator (Figure 50) daily.

1. Place a clean container under the fuel filter.
2. Loosen the drain plug on the bottom of the filter canister (Figure 50). Tighten the plug after draining.

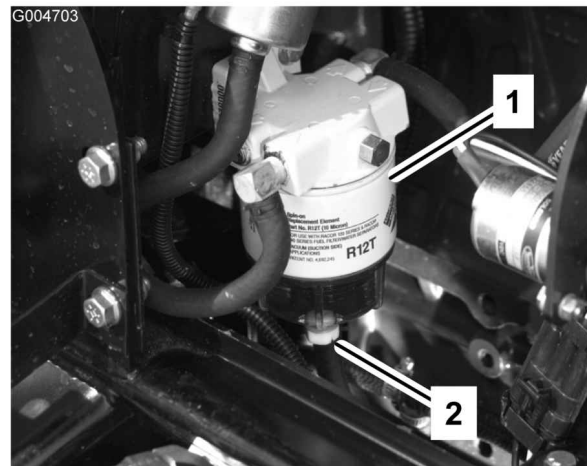

**Figure 50**

1. Water Separator
2. Drain plug

Replace filter canister after every 400 hours of operation.

- A. Clean the area where the filter canister mounts.
- B. Remove the filter canister and clean the mounting surface.
- C. Lubricate the gasket on the filter canister with clean oil.
- D. Install the filter canister by hand until the gasket contacts the mounting surface; then rotate it an additional 1/2 turn.

### Replacing the Fuel Pre-Filter

Replace the fuel pre-filter (Figure 51), located between fuel the tank and fuel pump, after every 400 operating hours or yearly, whichever occurs first.

1. Clamp both fuel lines that connect to the fuel filter so that fuel cannot drain when the lines are removed.
2. Loosen the hose clamps at both ends of the filter and pull the fuel lines off of the filter.

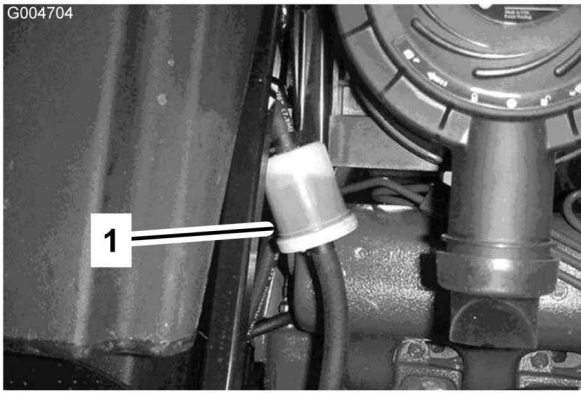

**Figure 51**

1. Fuel pre-filter

3. Slide the hose clamps onto the ends of the fuel lines. Push the fuel lines onto the fuel filter and secure them with the hose clamps. Be sure that the arrow on the side of the filter points toward the injection pump.

## Bleeding Air from the Injectors

1. Loosen the pipe connection to the Number 1 injector nozzle and holder assembly at the injection pump (Figure 52).

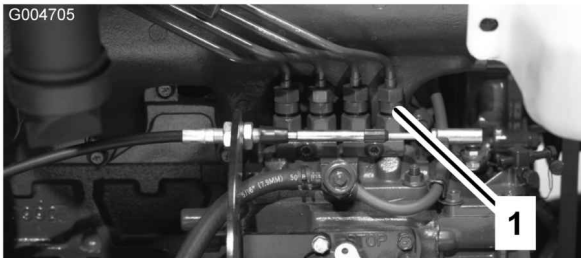

**Figure 52**

1. Number 1 injector nozzle
2. Move the throttle to the Fast position.
  3. Turn the key in the ignition switch to the Start position and watch the fuel flow around the connector. Turn the key to the Off position when solid flow is observed.
  4. Tighten the pipe connector securely.
  5. Repeat the procedure on the remaining nozzles.

## Electrical System Maintenance

### Activating, Charging, and Connecting the Battery

#### Warning

**CALIFORNIA**  
Proposition 65 Warning

Battery posts, terminals, and related accessories contain lead and lead compounds, chemicals known to the State of California to cause cancer and reproductive harm. Wash hands after handling.

**Note:** If the battery is not filled with electrolyte or activated, bulk electrolyte with 1.260 specific gravity must be purchased from a local battery supply outlet and added to the battery.

1. Raise the seat and secure it with the prop rod.
2. Remove the battery cover (Figure 53).



**Figure 53**

1. Battery cover
3. Remove the filler caps from the battery (Figure 54) and slowly fill each cell until electrolyte is just above the plates.



Battery electrolyte contains sulfuric acid which is a deadly poison and causes severe burns.

- Do not drink electrolyte and avoid contact with skin, eyes or clothing. Wear safety glasses to shield your eyes and rubber gloves to protect your hands.
- Fill the battery where clean water is always available for flushing the skin.



**Figure 54**

1. Battery

4. Install the filler caps and connect a 3 to 4 amp. battery charger to the battery posts. Charge the battery at a rate of 3 to 4 amperes for 4 to 8 hours.



Charging the battery produces gasses that can explode.

Never smoke near the battery and keep sparks and flames away from battery.

5. When the battery is charged, disconnect the charger from the electrical outlet and battery posts.
6. Remove the filler caps. Slowly add electrolyte to each cell until the level is up to the fill ring. Install the filler caps.

**Important:** Do not overfill the battery. Electrolyte will overflow onto other parts of the machine and severe corrosion and deterioration will result.

7. Install the positive cable (red) to the positive (+) terminal and the negative cable (black) to the negative (-) terminal of the battery and secure them with the bolts and nuts. Make sure that the positive (+) terminal is all of the way onto the post and the cable is positioned snug to the battery. The cable must not contact the battery cover. Slide the rubber boot over the positive terminal to prevent a possible short from occurring.



Battery terminals or metal tools could short against metal components causing sparks. Sparks can cause the battery gasses to explode, resulting in personal injury.

- When removing or installing the battery, do not allow the battery terminals to touch any metal parts of the machine.
- Do not allow metal tools to short between the battery terminals and metal parts of the machine.



Incorrect battery cable routing could damage the machine and cables causing sparks. Sparks can cause the battery gasses to explode, resulting in personal injury.

- Always disconnect the negative (black) battery cable before disconnecting the positive (red) cable.
- Always connect the positive (red) battery cable before connecting the negative (black) cable.

8. Coat both battery connections with Grafo 112X (skin-over) grease, Toro Part No. 505-47, petroleum jelly, or light grease to prevent

corrosion. Slide the rubber boot over the positive terminal.

9. Install the battery cover.

## Battery Care

Battery type is group 24.

**Important:** Before welding on the machine, disconnect the terminal connector from the alternator to prevent damage to the electrical system.

**Note:** Check the battery condition weekly or after every 50 hours of operation. Keep the terminals and the entire battery case clean because a dirty battery will discharge slowly. To clean the battery, wash the entire case with a solution of baking soda and water. Rinse with clear water. Coat the battery posts and cable connectors with Grafo 112X (skin-over) grease (Toro Part No. 505-47) or petroleum jelly to prevent corrosion.

## Fuses

There are 5 fuses in the electrical system. They are located below the operators control panel (Figure 55 and Figure 56).

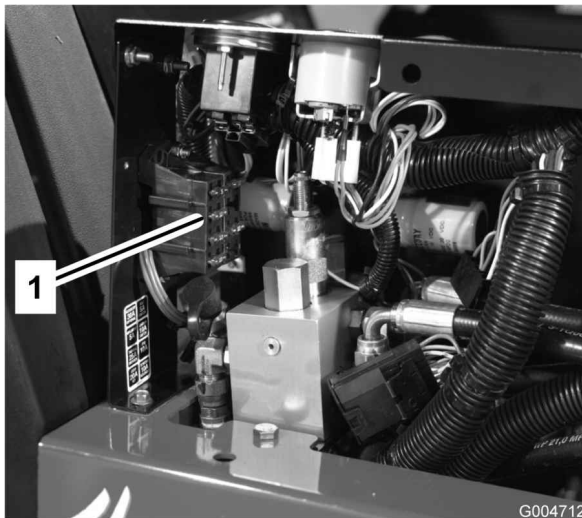

**Figure 55**

1. Fuses

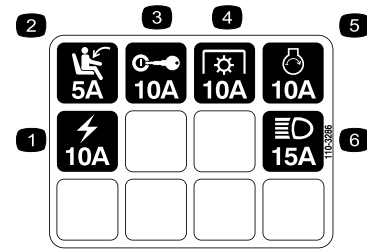

**Figure 56**

1. Power outlet
2. Seat switch
3. Ignition switch
4. Power Take Off (PTO)
5. Starter solenoid
6. Light kit

## Drive System Maintenance

### Changing the Planetary Gear Drive Oil

Change the oil initially after first 200 hours of operation. Thereafter change the oil every 800 hours, or yearly, whichever occurs first. Use a high quality SAE 85W-140 gear lube.

1. With the machine on a level surface, position the wheel so that the check/drain plug (Figure 57) is at the lowest position.

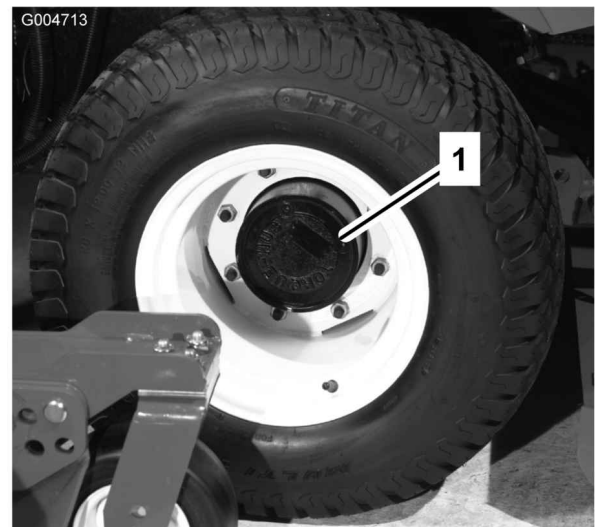
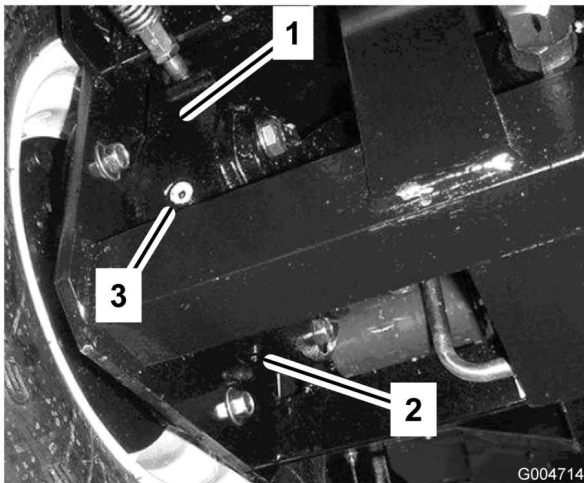

**Figure 57**

1. Check/drain plug

2. Place a drain pan under the hub, remove the plug, and allow the oil to drain.

- When all of the oil has drained, position the wheel so that the plug hole is at the ten or two o'clock position.
- Place a drain pan under the brake housing on the other side of the wheel (Figure 58).
- Remove the plug from the bottom of the housing and allow the oil to drain.
- When all of the oil has drained, install the plug in the housing.
- Remove check plug from brake housing (Figure 58).
- Add high quality SAE 85W-140 wt gear lube to the planetary fill hole (at the ten or two o'clock position) and to the check hole in brake housing until the level is up to the bottom of the planetary and brake housing check holes. Capacity is approximately 16 oz. (0.5 l).
- Install the plugs.
- Repeat the procedure on the opposite gear assembly.



**Figure 58**

- |                  |               |
|------------------|---------------|
| 1. Brake housing | 3. Check plug |
| 2. Drain plug    |               |

## Changing the Rear Axle Lubricant

Change the oil initially after the first 200 hours of operation and every 800 hours of operation thereafter.

- Position the machine on a level surface.
- Clean the area around the 3 drain plugs; 1 on each end and 1 in the center (Figure 59).

- Remove the check plugs to ease in draining of the oil.
- Remove the drain plugs and allow the oil to drain into the pans.

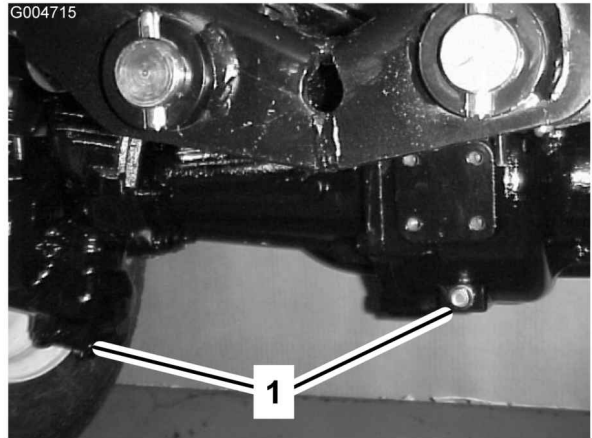

**Figure 59**

- Drain plug location

- Clean the area around the drain plug on the bottom of the gear box (Figure 60).
- Remove the drain plug from the gear box and allow the oil to drain into a pan. Remove the fill plug to ease in draining of the oil.

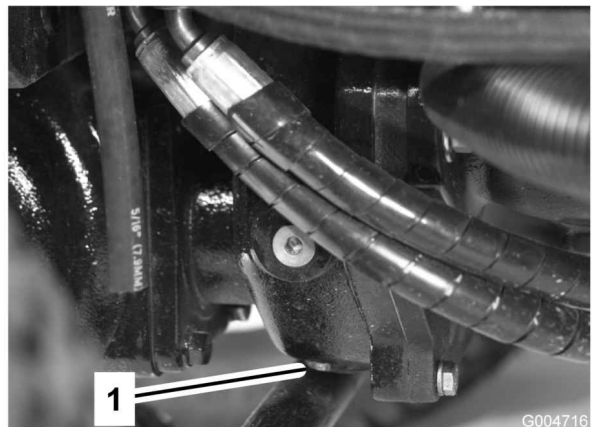

**Figure 60**

- Drain plug

- Add enough oil to bring the level up to the bottom of the check plug holes; refer to Checking the Rear Axle Lubricant, and Checking the Rear Axle Gear Box Lubricant.
- Install the plugs.

## Checking the Rear Wheel Toe-In

After every 800 operating hours or annually, check the rear wheel toe-in.

1. Measure the center-to-center distance (at axle height) at the front and rear of the steering tires. The front measurement must be 1/4 inch (6 mm) less than the rear measurement.
2. To adjust, loosen the clamps at both ends of the tie rods.
3. Rotate the tie rod end to move the front of the tire inward or outward.
4. Tighten the tie rod clamps when the adjustment is correct.

## Cooling System Maintenance

### Servicing the Engine Cooling System

Remove debris from the oil cooler and radiator daily. Clean them more frequently in dirty conditions.

1. Turn the engine off and raise the hood. Clean the engine area thoroughly of all debris.
2. Remove the knobs (Figure 61) securing the oil cooler to the frame.

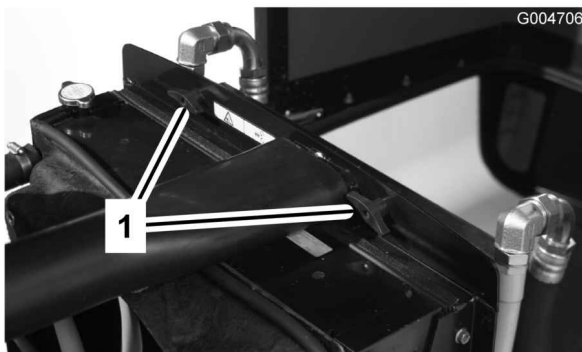
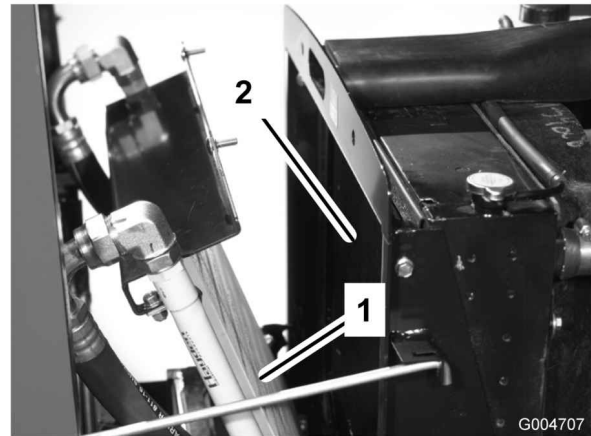

**Figure 61**

1. Knobs

3. Pivot the oil cooler rearward. Clean both sides of the oil cooler and radiator area (Figure 62) thoroughly with compressed air.

**Important:** Cleaning the radiator or oil cooler with water can promote premature corrosion and damage to components.



**Figure 62**

1. Oil cooler
2. Radiator

4. Pivot the oil cooler back into position. Secure it to the frame with the knobs and close the hood.

## Brake Maintenance

### Adjusting the Service Brakes

Adjust the service brakes when there is more than 1 inch (25 mm) of “free travel” of the brake pedal, or when the brakes do not work effectively. Free travel is the distance the brake pedal moves before braking resistance is felt.

1. Disengage the locking latch from the brake pedals so that both pedals work independently of each other.
2. To reduce free travel of the brake pedals, tighten the brakes:
  - A. Loosen the front nut on the threaded end of the brake cable.
  - B. Tighten the rear nut to move the cable backward until the brake pedals have 1/2 to 1 inch (13 to 25 mm) of free travel.
  - C. Tighten the front nuts after the brakes are adjusted correctly.

# Belt Maintenance

## Servicing the Alternator Belt

Check the condition and tension of the belts (Figure 63) after every 100 operating hours.

1. Proper tension will allow 3/8 inch (10 mm) deflection when a force of 10 lb is applied on the belt midway between the pulleys.
2. If the deflection is not 3/8 inch (10 mm), loosen the alternator mounting bolts (Figure 63). Increase or decrease the alternator belt tension and tighten the bolts. Check the deflection of the belt again to ensure that the tension is correct.

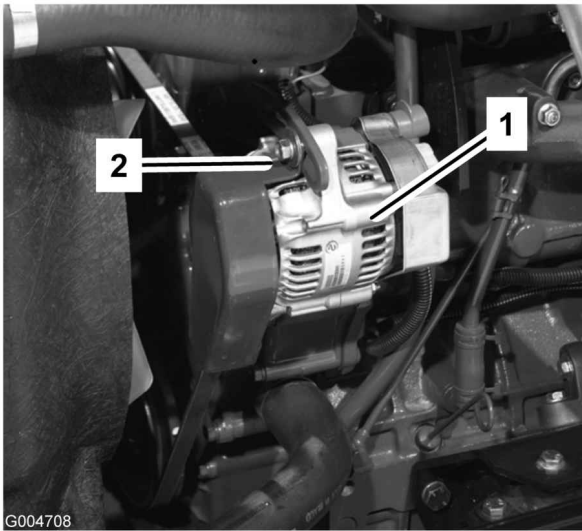

**Figure 63**

1. Alternator                      2. Mounting bolt

## Re-tensioning the Blade Drive Belts

Check the condition and tension of the cutting unit drive belts initially after 8 hours of operation and every 50 operating hours thereafter.

When properly tensioned, the extension spring (hook to hook) measurement should be approximately 3.50 ±.25 inch (inside). Once the correct spring tension is attained, adjust the stop bolt (carriage bolt) until there is approximately .125 +.060/-0.000 inch clearance between the head of the bolt and the idler arm (Figure 64).

**Note:** Make sure the belt is positioned on the spring side of the belt guide (Figure 64).

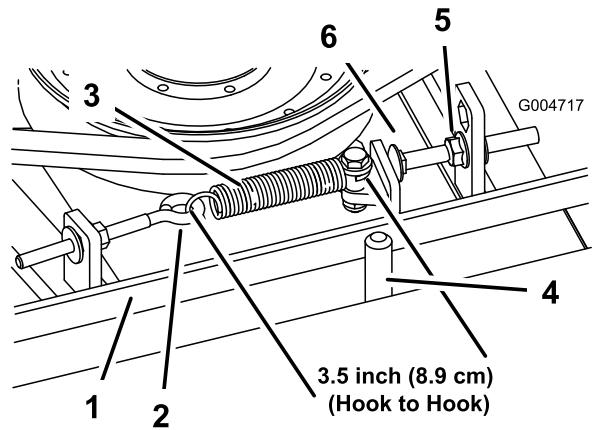

**Figure 64**

- |                     |               |
|---------------------|---------------|
| 1. Belt             | 4. Belt guide |
| 2. Eye bolt         | 5. Flange nut |
| 3. Extension spring | 6. Stop bolt  |

## Replacing the Blade Drive Belt

The blade drive belt, tensioned by the spring loaded idler pulley, is very durable. However, after many hours of use, the belt will show signs of wear. Signs of a worn belt are: squealing when belt is rotating, blades slipping when cutting grass, frayed edges, burn marks and cracks. Replace the belt if any of these conditions are evident.

1. Lower the cutting unit to the shop floor. Remove the belt covers from the top of the cutting unit and set the covers aside.
2. Loosen the eye bolt allowing the removal of the extension spring (Figure 64).
3. Loosen the flange nut securing the stop bolt to the mounting tab. Back off the nut enough to allow the idler arm to pass by the stop bolt (Figure 64). Move the idler pulley away from the belt to release belt tension.

**Note:** If the stop bolt is ever removed from the mounting tab, make sure it is reinstalled in the hole that aligns the stop bolt head with the idler arm.

4. Remove the bolts securing the hydraulic motor to the cutting unit (Figure 65). Lift the motor off of the cutting unit and lay it on top of the cutting unit.

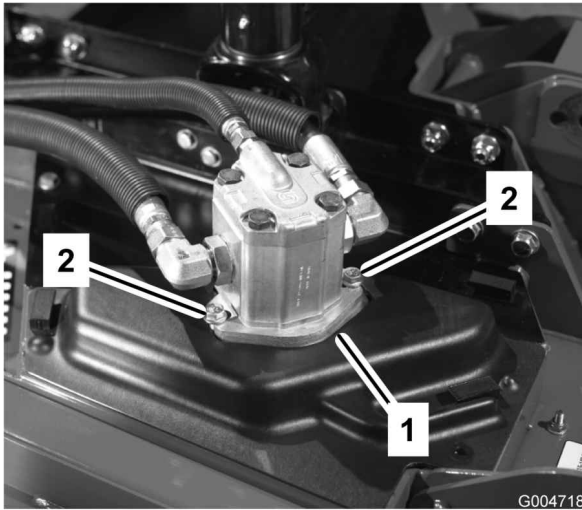

**Figure 65**

1. Hydraulic motor
2. Mounting bolts

5. Remove the old belt from around the spindle pulleys and idler pulley.
6. Route the new belt around the spindle pulleys and idler pulley assembly.
7. Position the hydraulic motor on the cutting unit after routing the belt around the pulleys. Mount the motor to the cutting unit with the bolts previously removed.

**Note:** Make sure the belt is positioned on the spring side of the belt guide (Figure 64).

8. Reconnect the extension spring (Figure 64) to the eye bolt and tension the belt as follows:
  - When properly tensioned, the extension spring (hook to hook) measurement should be approximately 3.50 ±.25 inch (inside).
  - Once the correct spring tension is attained, adjust the stop bolt (carriage bolt) until there is approximately .125 +.060/-.000 inch clearance between the head of the bolt and the idler arm.

## Controls System Maintenance

### Adjusting the Throttle

Adjust the throttle cable (Figure 66) so that the governor lever on the engine contacts the low and high speed set bolts before the throttle lever contacts the slot in the control panel.

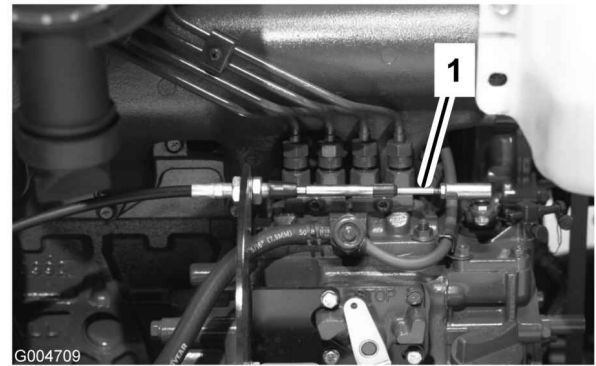

**Figure 66**

1. Throttle cable

### Adjusting the Traction Pedal Linkage

The traction pedal should reach full stroke at the same time it makes contact with the stop. If it does not, perform the following procedure:

1. Park the machine on a level surface, stop the engine, and lower the cutting units to the floor. Remove the ignition key.
2. Check the traction pedal stop adjustment. The distance from the top of the stand to the top of the stop must be 1-1/2 inch (38 mm) (Figure 67). Loosen the nuts and adjust, as required.

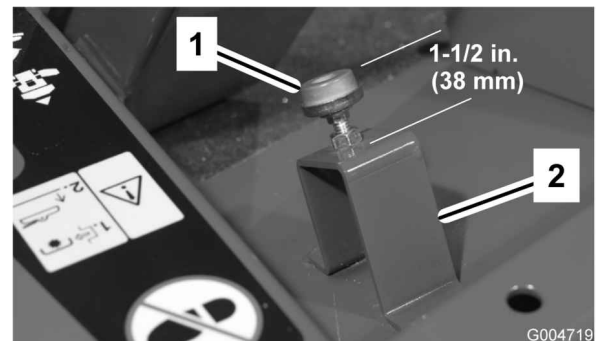

**Figure 67**

1. Traction pedal stop
2. Stand

3. Loosen the jam nuts on the rod end and adjust the traction rod length (Figure 68) so that the pedal contacts the pedal stop when the pump lever reaches full stroke. Secure the jam nuts.

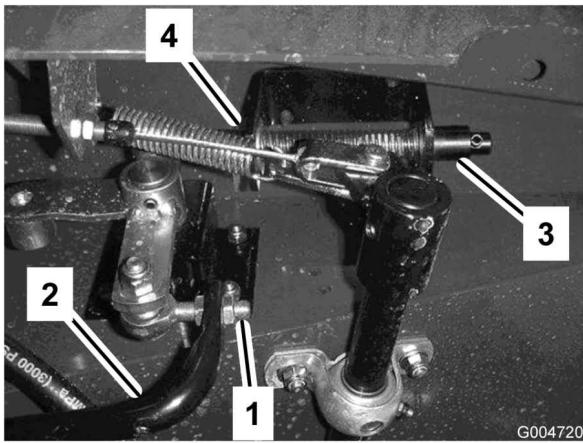

**Figure 68**

- |                 |                                   |
|-----------------|-----------------------------------|
| 1. Rod end      | 3. Neutral return spring assembly |
| 2. Traction rod | 4. Jam nut                        |

4. Turn the key switch to the run position without starting the engine. Loosen the jam nut and adjust the neutral return spring assembly shaft length until the audible alarm begins to sound. Secure the jam nut.
5. Turn the key switch off.

## Hydraulic System Maintenance

### Changing the Hydraulic Fluid

Change the hydraulic fluid after every 800 operating hours, in normal conditions. If the fluid becomes contaminated, contact your local Toro distributor because the system must be flushed. Contaminated fluid looks milky or black when compared to clean oil.

1. Turn the engine off and raise the hood.
2. Loosen the drain valve on the bottom of the reservoir and let the hydraulic fluid flow into large drain pan. Close the valve when the hydraulic fluid stops draining.
3. Fill the reservoir (Figure 68) with approximately 8 gallons (30 l) of hydraulic fluid; refer to Checking the Hydraulic Fluid.

**Important:** Use only the hydraulic fluids specified. Other fluids could cause system damage.

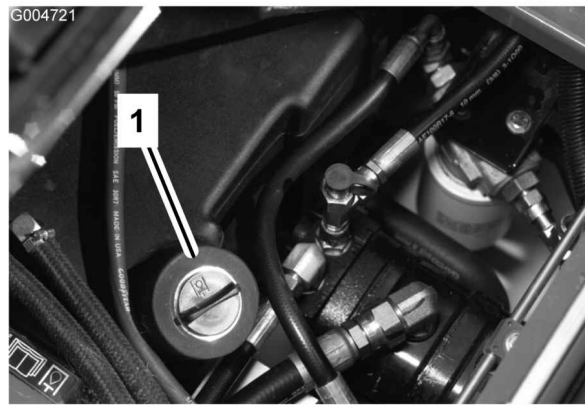

**Figure 69**

1. Hydraulic reservoir
4. Install the reservoir cap. Start the engine and use all of the hydraulic controls to distribute hydraulic fluid throughout the system. Also check for leaks; then stop the engine.
5. Check the fluid level and add enough to raise level the level to the FULL mark on the dipstick. **Do not overfill.**

### Replacing the Hydraulic Filters

Change the 2 hydraulic filters initially after the first 200 operating hours. Thereafter, change the filters after every 800 operating hours, in normal conditions.

Use Toro replacement filters (Part No. 94-2621 for the left side of the machine and 75-1310 for the right side of the machine).

**Important:** Use of any other filter may void the warranty on some components.

1. Position the machine on a level surface, lower the cutting units, stop the engine, engage the parking brakes, and remove the ignition key.
2. Clean the area around the filter mounting area. Place a drain pan under the filter and remove the filter (Figure 70).

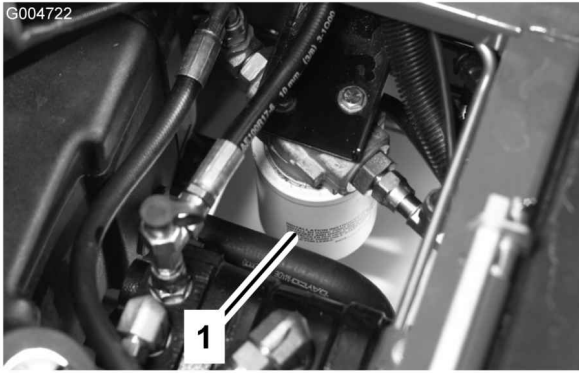

**Figure 70**

3. Lubricate the new filter gasket and fill the filter with hydraulic fluid.
4. Ensure that the filter mounting area is clean. Screw the filter on until the gasket contacts the mounting plate; then tighten the filter an additional 1/2 turn.
5. Start the engine and let it run for about two minutes to purge air from the system. Stop the engine and check for leaks.

## Checking the Hydraulic Lines and Hoses

Inspect the hydraulic lines and hoses daily for leaks, kinked lines, loose mounting supports, wear, loose fittings, weather deterioration, and chemical deterioration. Make all necessary repairs before operating.

**Hydraulic fluid escaping under pressure can penetrate skin and cause injury.**

- Make sure all hydraulic fluid hoses and lines are in good condition and all hydraulic connections and fittings are tight before applying pressure to the hydraulic system.
- Keep your body and hands away from pin hole leaks or nozzles that eject high pressure hydraulic fluid.
- Use cardboard or paper to find hydraulic leaks.
- Safely relieve all pressure in the hydraulic system before performing any work on the hydraulic system.
- Seek immediate medical attention if fluid is injected into skin.

## Hydraulic System Test Ports

The test ports are used to test the pressure in the hydraulic circuits. Contact your local Toro distributor for assistance.

Test Port A (Figure 71), located on the left side of the machine, is used to measure the forward traction pressure.

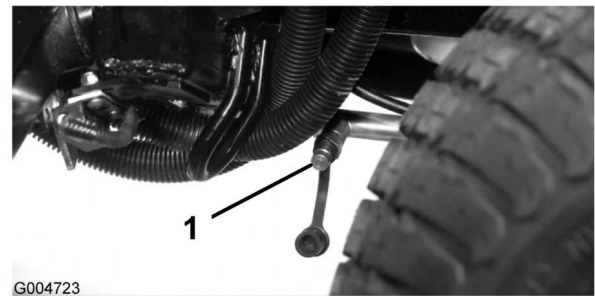

**Figure 71**

1. Test port A

Test Port B (Figure 72), located on the right side of the machine, is used to measure the reverse traction pressure.

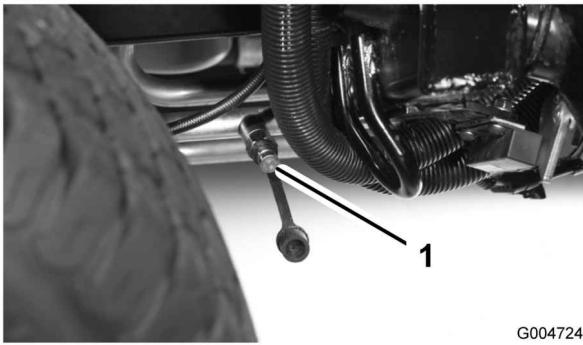

G004724

**Figure 72**

1. Test port B

Test Port C (Figure 73), located on the left side of the machine, is used to measure the left cutting unit pressure.

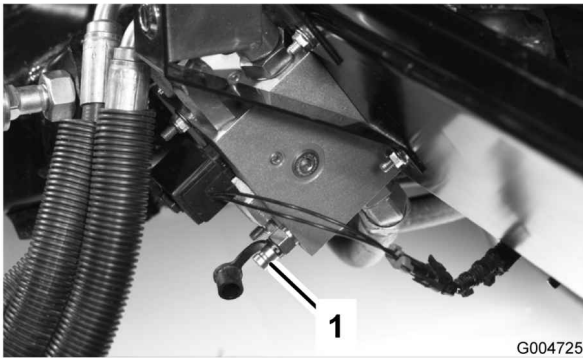

G004725

**Figure 73**

1. Test port C

Test Port D (Figure 74), located on the right side of the machine, is used to measure the right cutting unit pressure.

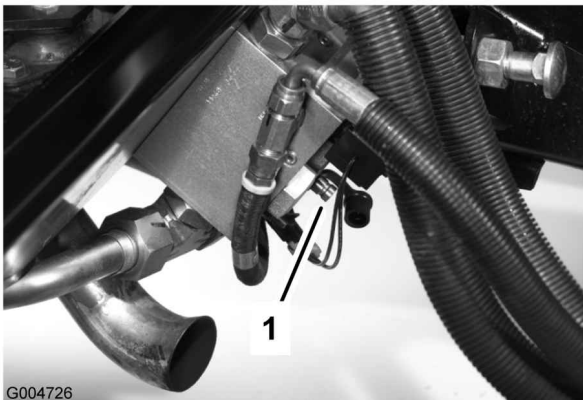

G004726

**Figure 74**

1. Test port D

Test Port E (Figure 75), located under the radiator, is used to measure the four-wheel drive pressure in reverse.

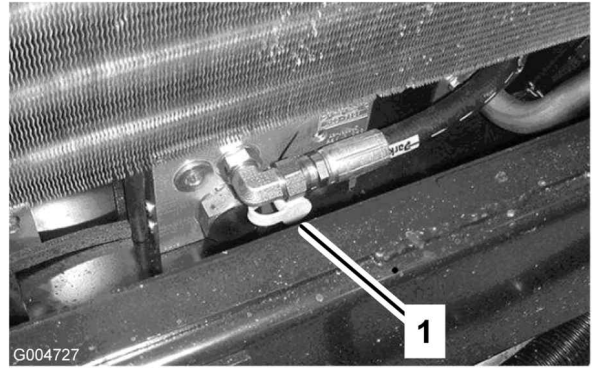

G004727

**Figure 75**

1. Test port E

Test Port F (Figure 76), located under the seat, is used to measure the lift circuit pressure.

Test Port G (Figure 76), located under the seat, is used to measure the charge circuit pressure.

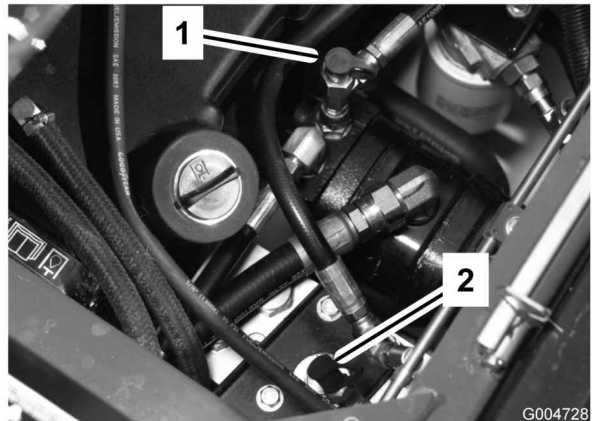

G004728

**Figure 76**

1. Test port F
2. Test port G

Test Port H (Figure 77) is used to measure the front cutting unit circuit pressure.

Test Port J (Figure 77) is used to measure the steering circuit pressure.

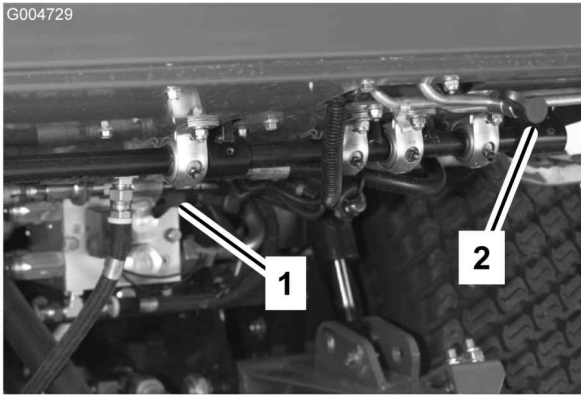

**Figure 77**

1. Test port I
2. Test port H

The counterbalance test port (Figure 78) is used to adjust the pressure in the counterbalance circuit. Recommended counterbalance pressure is 470 psi (3241 kPa). To adjust the counterbalance pressure, rotate the adjusting screw (Figure 78) clockwise to increase the pressure or counterclockwise to decrease the pressure.

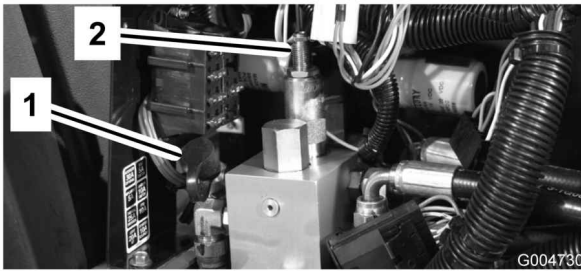
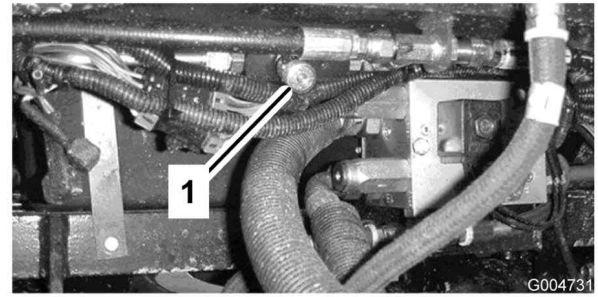

**Figure 78**

1. Counterbalance test port
2. Counterbalance adjusting screw

## Adjusting the Cutting Unit Flow Control

The flow control valve (Figure 79) is used to adjust the rate at which the cutting unit lowers.



**Figure 79**

1. Flow control valve

## Mower Maintenance

### Pivoting (Tilting) the Front Cutting Unit Upright

**Note:** Although not needed for normal maintenance procedures, the front cutting unit can be pivoted (tilted) to an upright position. Should you desire to tilt the cutting unit, proceed as follows:

1. Raise the center and wing cutting units slightly off of the floor, set the parking brake, and stop the engine. Remove the ignition key.
2. Remove the hairpin cotter securing dampers to lift arms (Figure 80). Pivot damper toward deck housing.

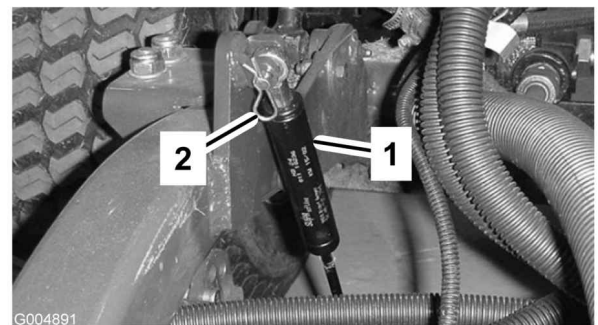

**Figure 80**

1. Damper
2. Hair pin cotter

3. Remove the hairpin cotter and clevis pin securing the height-of-cut chains to the rear of the cutting unit (Figure 81).

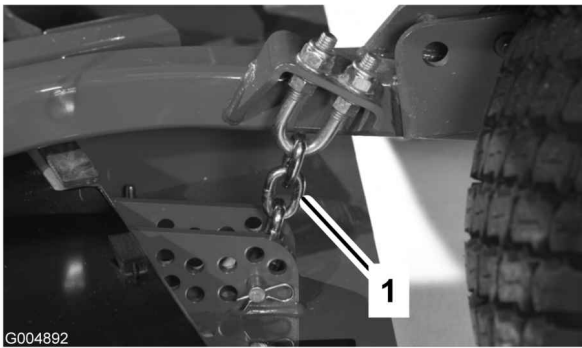

**Figure 81**

1. Height-of-cut chain

4. Start the engine and slowly raise the center cutting unit.
5. Slowly raise each wing cutting until the center of gravity shifts and the deck starts to rotate into the upright position. Stop the engine and remove the ignition key.

## Pivoting the Front Cutting Unit Down

1. Slowly lower wing cutting units until the center of gravity shifts and the center cutting unit rotates downward.
2. Sit on the seat, start the engine, and lower the center cutting unit until it is slightly off of the floor.
3. Secure the height-of-cut chains to the rear of the cutting unit.
4. Pivot dampers upward into position and secure with clevis pin and cotter pin.

## Adjusting the Cutting Unit Pitch

### Measuring the Cutting Unit Pitch

Cutting unit pitch is the difference in height-of-cut from the front of the blade plane to the back of the blade plane. Toro recommends a blade pitch of 1/4 inch (6 mm). That is the back of the blade plane is 1/4 inch (6 mm) higher than the front.

1. Position the machine on a level surface on the shop floor.
2. Set the cutting unit to the desired height-of-cut.

3. Rotate 1 blade so that it points straight forward.
4. Using a short ruler, measure from the floor to the front tip of the blade. Rotate the blade tip to the rear and measure from the floor to the tip of the blade.
5. Subtract the front dimension from the rear dimension to calculate the blade pitch.

## Adjusting the Front Cutting Unit

1. Loosen the jam nuts on the top or bottom of the height-of-cut chain U-bolt (Figure 82).
2. Adjust the other set of nuts to raise or lower the rear of the cutting unit and attain the correct cutting unit pitch.
3. Tighten the jam nuts.

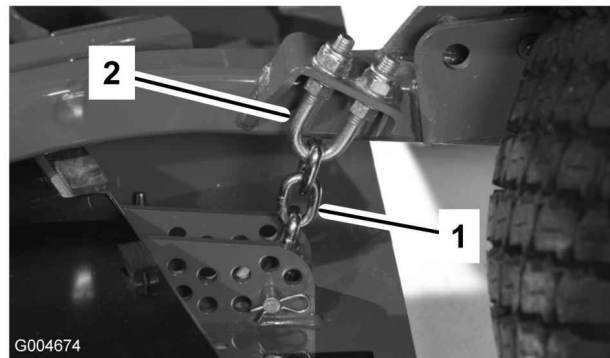
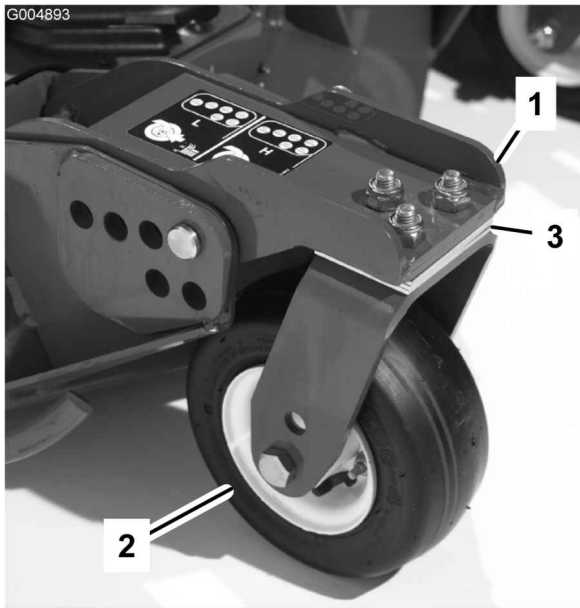

**Figure 82**

1. Height-of-cut chain
2. U-bolt

## Adjusting the Wing Cutting Units

1. Remove the cap screws and nuts securing the castor arm to the castor fork (Figure 83).
2. Reposition the shims, as required, to raise or lower the castor wheel until the cutting unit has the correct pitch.
3. Install the cap screws and nuts.



**Figure 83**

- |                   |                        |
|-------------------|------------------------|
| 1. Castor wheel   | 4. Shims               |
| 2. Tensioning cap | 5. Axle mounting holes |
| 3. Spacers        |                        |

## Servicing the Castor Arm Bushings

The castor arms have bushings pressed into the top and bottom of the tube and after many hours of operation, the bushings will wear. To check the bushings, move the castor fork back and forth and from side to side. If the castor spindle is loose inside the bushings, the bushings are worn and must be replaced.

1. Raise the cutting unit so that the wheels are off of the floor. Block the cutting unit so that it cannot accidentally fall.
2. Remove the tensioning cap, spacer(s), and thrust washer from the top of the castor spindle.
3. Pull the castor spindle out of the mounting tube. Allow the thrust washer and spacer(s) to remain on the bottom of the spindle.
4. Insert a pin punch into the top or bottom of the mounting tube and drive the bushing out of the tube (Figure 84). Also drive the other bushing out of the tube. Clean the inside of the tubes to remove dirt.

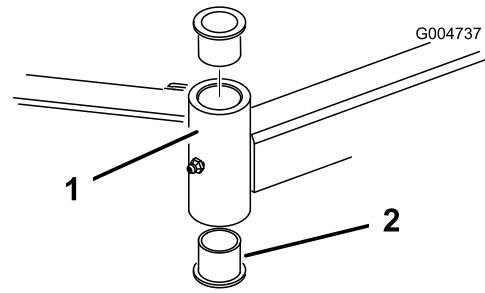

**Figure 84**

- |                    |             |
|--------------------|-------------|
| 1. Castor arm tube | 2. Bushings |
|--------------------|-------------|

5. Apply grease to the inside and outside of the new bushings. Using a hammer and flat plate, drive the bushings into the mounting tube.
6. Inspect the castor spindle for wear and replace it if it is damaged.
7. Push the castor spindle through the bushings and mounting tube. Slide the thrust washer and spacer(s) onto the spindle. Install the tensioning cap on the castor spindle to retain all parts in place.

## Servicing the Castor Wheels and Bearings

1. Remove the locknut from the bolt holding the castor wheel assembly between the castor fork (Figure 85) or the castor pivot arm (Figure 86). Grasp the castor wheel and slide the bolt out of the fork or pivot arm.

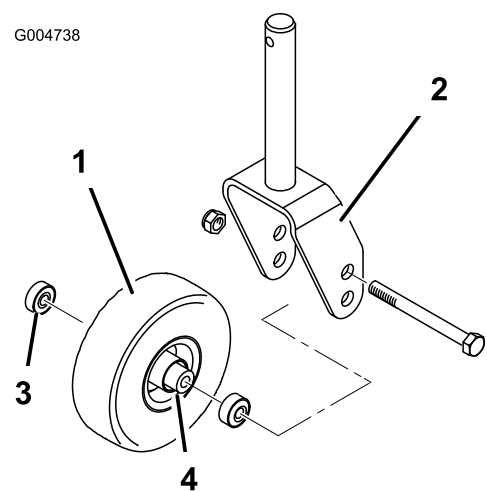

**Figure 85**

- |                 |                   |
|-----------------|-------------------|
| 1. Castor wheel | 3. Bearing        |
| 2. Castor fork  | 4. Bearing spacer |

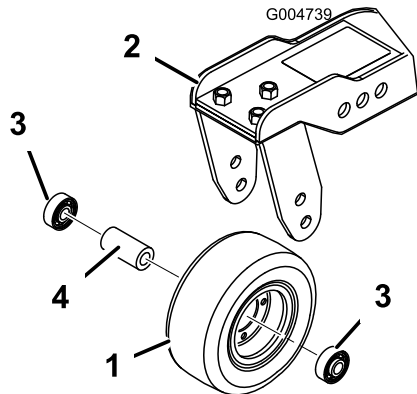

**Figure 86**

- |                     |                   |
|---------------------|-------------------|
| 1. Castor wheel     | 3. Bearing        |
| 2. Castor pivot arm | 4. Bearing spacer |

- Remove the bearing from the wheel hub and allow the bearing spacer to fall out (Figure 85 and Figure 86). Remove the bearing from the opposite side of the wheel hub.
- Check the bearings, spacer, and inside of the wheel hub for wear. Replace any damaged parts.
- To assemble the castor wheel, push the bearing into the wheel hub. When installing the bearings, press on the outer race of the bearing.
- Slide the bearing spacer into the wheel hub. Push the other bearing into the open end of the wheel hub to captivate the bearing spacer inside the wheel hub.
- Install the castor wheel assembly between the castor fork and secure it in place with the bolt and locknut.

## Replacing the Cutting Unit Hinge Covers

The hinge cover prevents debris from escaping at hinge points between cutting units. If cover(s) ever become damaged or worn they must be replaced.

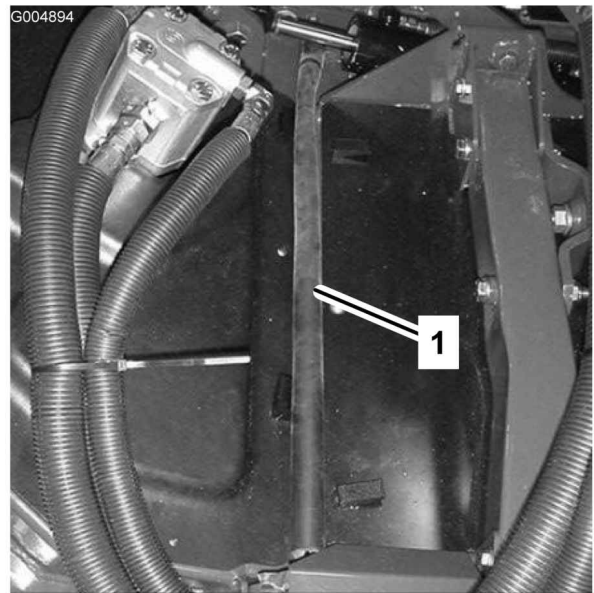
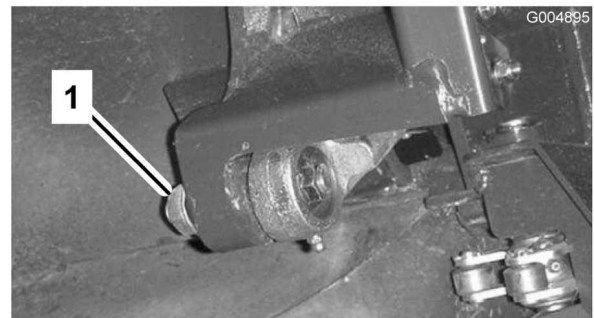

**Figure 87**

- Hinge cover

## Tightening the Locknuts

After the first 50 hours, the lock nuts on the lower pivot links (Figure 88), the lift arm pins (Figure 89) and the wing deck cylinder mounts (Figure 90) must be torqued to 160 to 180 ft-lb (216 to 244 N·m).



**Figure 88**

- Lower pivot link nut (4)

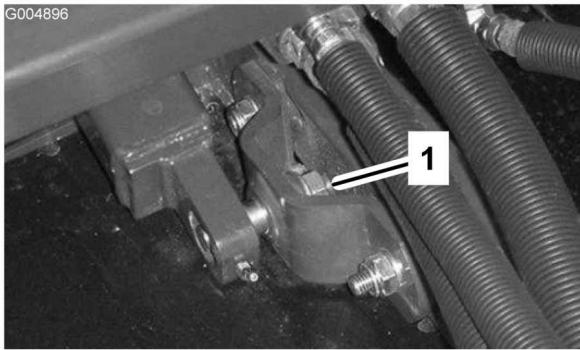

**Figure 89**

1. Lift arm pin nut (2)

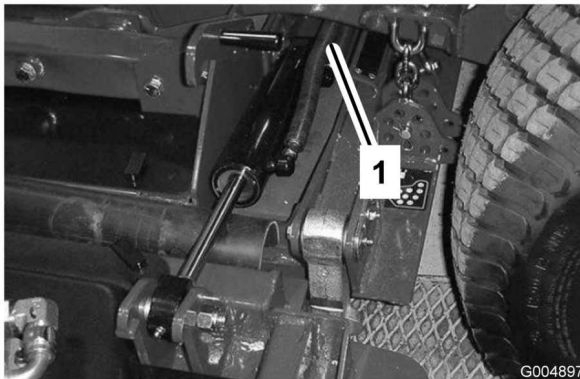

**Figure 90**

1. Wing deck cylinder pin nut (2)

## Blade Maintenance

### Checking for a Bent Blade

1. Position the machine on a level surface. Raise the cutting unit, engage the parking brake, put the traction pedal in neutral, put the PTO lever in the Off position, stop the engine, and remove the ignition key. Block the cutting unit to prevent it from accidentally falling.
2. Rotate the blade until the ends face forward and backward (Figure 91). Measure from the inside of the cutting unit to the cutting edge at the front of the blade. Remember this dimension.

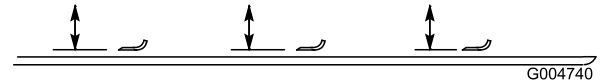

**Figure 91**

3. Rotate the opposite end of the blade forward. Measure between the cutting unit and cutting edge of the blade at the same position as in step 2. The difference between the dimensions obtained in steps 2 and 3 must not exceed 1/8 inch (3 mm). If the dimension exceeds 1/8 inch (3 mm), the blade is bent and must be replaced; refer to Removing and Installing the Cutter Blade.

### Removing and Installing the Cutter Blade(s)

The blade must be replaced if a solid object is hit, the blade is out of balance, or if the blade is bent. Always use genuine Toro replacement blades to be sure of safety and optimum performance. Never use replacement blades made by other manufacturers because they could be dangerous.

1. Raise the cutting unit to the highest position, engage the parking brake, stop the engine, and remove the ignition key. Block the cutting unit to prevent it from accidentally falling.
2. Grasp the end of the blade using a rag or thickly padded glove. Remove the blade bolt, anti-scalp cup, and blade from the spindle shaft (Figure 92).
3. Install the blade, anti-scalp cup, and blade bolt. Tighten the blade bolt to 85 to 110 ft-lb (115 to 149 N·m).

**Important:** The curved part of the blade must be pointing toward the inside of the cutting unit to ensure proper cutting.

**Note:** After striking a foreign object, torque all the spindle pulley nuts to 130 to 150 ft-lb (176 to 203 N·m).

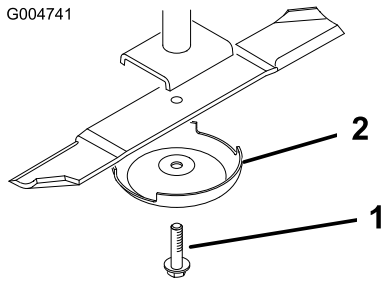

**Figure 92**

1. Blade bolt                      2. Anti-scalp cup

## Inspecting and Sharpening the Cutter Blade(s)



A worn or damaged blade can break, and a piece of the blade could be thrown into the operator's or bystander's area, resulting in serious personal injury or death. Trying to repair a damaged blade may result in discontinued safety certification of the product.

- Inspect the blade periodically for wear or damage.
- Never try to straighten a blade that is bent or weld a broken or cracked blade.
- Replace a worn or damaged blade.

Two areas must be considered when checking and servicing the cutter blade—the sail and the cutting edge. Both cutting edges and the sail, which is the turned up portion opposite the cutting edge, contribute to a good quality-of-cut. The sail is important because it lifts the grass up straight, thereby producing an even cut. However, the sail will gradually wear down during operation, and this condition is normal. As the sail wears down, the quality-of-cut will degrade somewhat, although the cutting edges are sharp. The cutting edge of the blade must be sharp so that the grass is cut rather than torn. A dull cutting edge is evident when the tips of the grass appear brown and shredded. Sharpen the cutting edges to correct this condition.

1. Position the machine on a level surface. Raise the cutting unit, engage the parking brake, put the traction pedal in neutral, put the PTO

lever in the Off position, stop the engine, and remove the ignition key.

2. Examine the cutting ends of the blade carefully, especially where the flat and curved parts of the blade meet (Figure 93). Since sand and abrasive material can wear away the metal that connects the flat and curved parts of the blade, check the blade before using the mower. If wear is noticed (Figure 93), replace the blade.

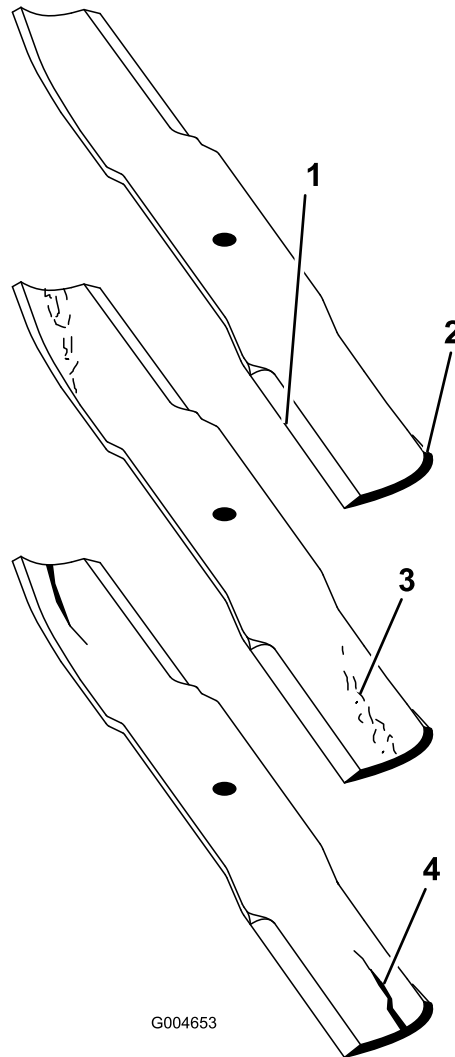

G004653

**Figure 93**

1. Cutting Edge                      3. Wear/slot Forming  
2. Curved Area                      4. Crack

3. Examine the cutting edges of all of the blades. Sharpen the cutting edges if they are dull or nicked. Sharpen only the top of the cutting edge and maintain the original cutting angle to make sure of sharpness (Figure 94). The blade will remain balanced if the same amount of metal is removed from both cutting edges.



If the blade is allowed to wear, a slot will form between the sail and flat part of the blade (Figure 93). Eventually a piece of the blade may break off and be thrown from under the housing, possibly resulting in serious injury to you or bystanders.

- Inspect the blade periodically for wear or damage.
- Never try to straighten a blade that is bent or weld a broken or cracked blade.
- Replace a worn or damaged blade.

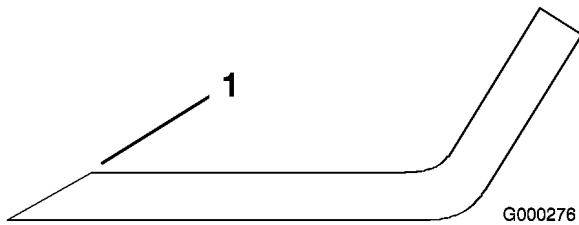

**Figure 94**

1. Sharpen at original angle

**Note:** Remove the blades and sharpen them on a grinder. After sharpening the cutting edges, install the blade with the anti-scalp cup and blade bolt; refer to Removing and Installing the Cutter Blade(s).

## Correcting Cutting Unit Mismatch

If there is mismatch between the blades, on a single cutting unit, the grass will appear streaked when it is cut. This problem can be corrected by making sure that the blades are straight and all of the blades are cutting on the same plane.

1. Using a 3 foot (1 meter) long carpenters level, find a level surface on the shop floor.
2. Raise the height-of-cut to the highest position; refer to Adjusting the Height-Of-Cut.
3. Lower the cutting unit onto the flat surface. Remove the covers from the top of the cutting unit.
4. Loosen the flange nut securing the idler pulley to release the belt tension.

5. Rotate the blades until the ends face forward and backward. Measure from the floor to the front tip of the cutting edge. Remember this dimension. Then rotate the same blade so that the opposite end is forward, and measure again. The difference between the dimensions must not exceed 1/8 inch (3 mm). If the dimension exceeds 1/8 inch (3 mm), replace the blade because it is bent. Make sure to measure all of the blades.
  6. Compare the measurements of the outer blades with the center blade. The center blade must not be more than 3/8 inch (10 mm) lower than the outer blades. If the center blade is more than 3/8 inch (10 mm) lower than the outer blades, proceed to step 7 and add shims between the spindle housing and the bottom of the cutting unit.
  7. Remove the bolts, flat washers, lock washers, and nuts from the outer spindle in the area where the shims must be added. To raise or lower the blade, add a shim, Part No. 3256-24, between the spindle housing and the bottom of the cutting unit. Continue to check the alignment of the blades and add shims until the tips of the blades are within the required dimension.
- Important:** Do not use more than three shims at any one hole location. Use decreasing numbers of shims in adjacent holes if more than one shim is added to any one hole location.
8. Adjust the idler pulley and install the belt covers.

## Spark Arrestor Maintenance

### Servicing the Spark Arrestor Muffler

Every 200 hours operation, clear the muffler of carbon buildup.

1. Remove the pipe plug from the clean-out port at the lower side of the muffler.



**The muffler may be hot and could cause injury.**

**Be careful while working around the muffler.**

2. Start the engine. Plug the normal muffler exit with a block of wood or metal plate so that the exhaust flow will be forced out of the clean-out port. Continue to block the exit until carbon deposits cease coming out of the port.



**Do not stand in line with the clean-out port.**

**Always wear safety glasses.**

3. Stop the engine and replace the pipe plug.

# Storage

## Preparing for Seasonal Storage

### Traction Unit

1. Thoroughly clean the traction unit, cutting units, and the engine.
2. Check the tire pressure; refer to Checking the Tire Pressure procedure in Operation, page 19.
3. Check all fasteners for looseness; tighten as necessary.
4. Grease or oil all grease fittings and pivot points. Wipe up any excess lubricant.
5. Lightly sand and use touch-up paint on painted areas that are scratched, chipped, or rusted. Repair any dents in the metal body.
6. Service the battery and cables as follows:
  - A. Remove the battery terminals from the battery posts.
  - B. Clean the battery, terminals, and posts with a wire brush and baking soda solution.
  - C. Coat the cable terminals and battery posts with Grafo 112X skin-over grease (Toro Part No. 505-47) or petroleum jelly to prevent corrosion.
  - D. Slowly recharge the battery every 60 days for 24 hours to prevent lead sulfation of the battery.

### Engine

1. Drain the engine oil from the oil pan and install the drain plug.
2. Remove and discard the oil filter. Install a new oil filter.
3. Refill the oil pan with 8 qt (7.6 l) of SAE 10W-30 CD, CE, CF, CF-4, or CG-4 motor oil.
4. Start the engine and run it at idle speed for approximately two minutes.
5. Stop the engine.
6. Flush the fuel tank with fresh, clean diesel fuel.
7. Secure all of the fuel system fittings.
8. Thoroughly clean and service the air cleaner assembly.

9. Seal the air cleaner inlet and the exhaust outlet with weatherproof tape.
10. Check the anti freeze protection and add a 50/50 solution of water and ethylene glycol anti-freeze as needed for the expected minimum temperature in your area.

# Schematics

G004898

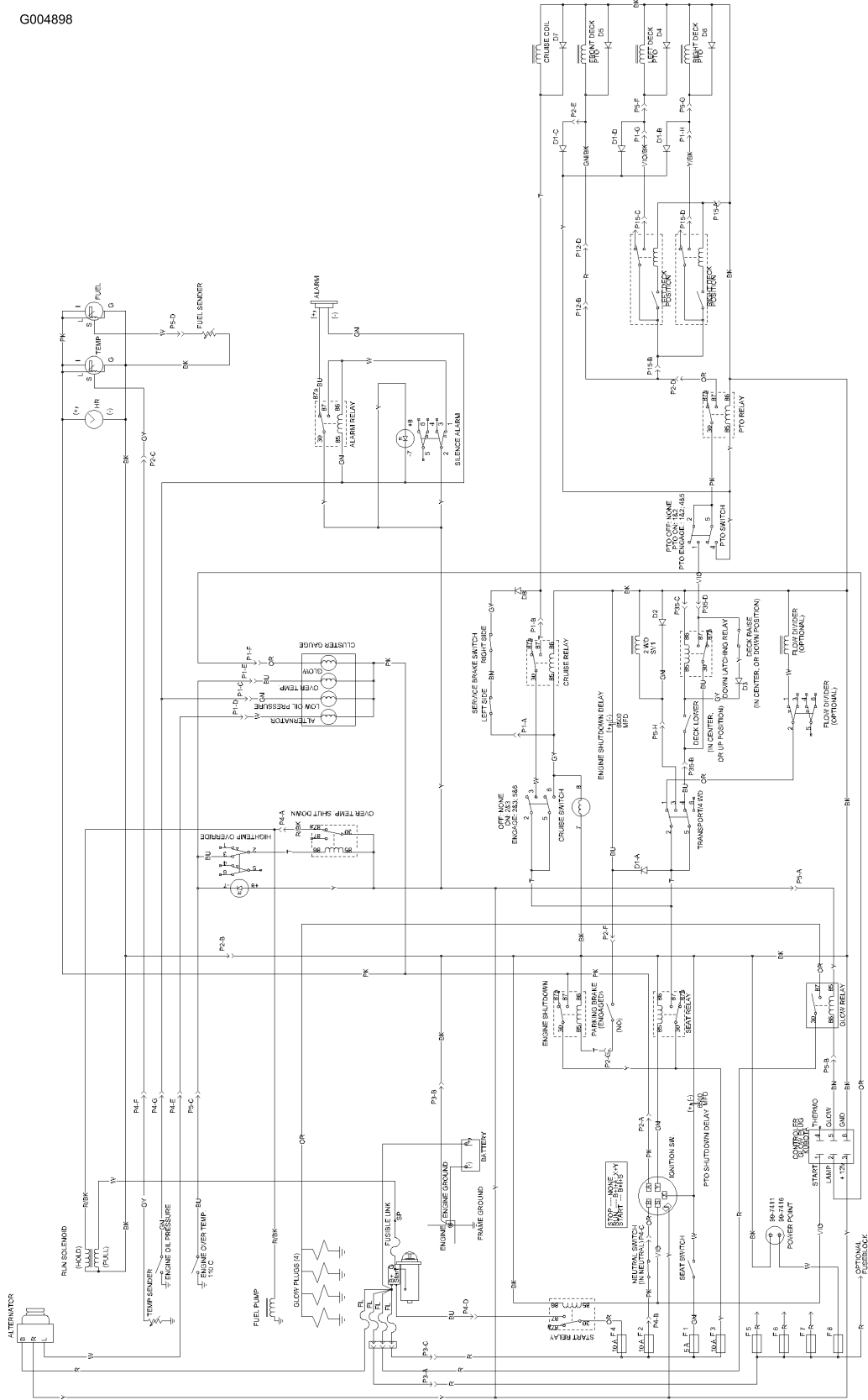

Electrical Schematic (Rev. A)

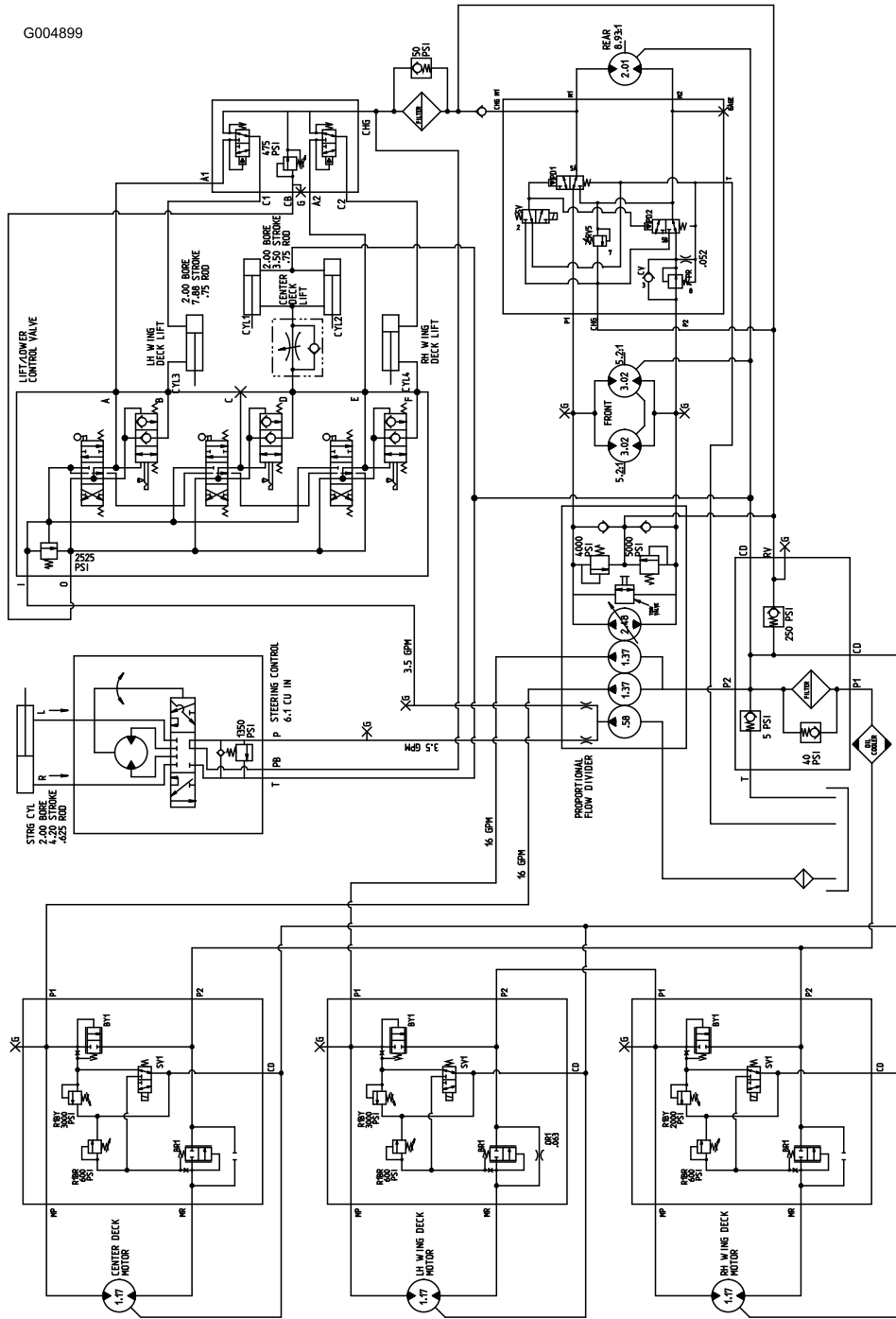

Hydraulic Schematic (Rev. A)







## The Toro General Commercial Products Warranty

A Two-Year Limited Warranty

### Conditions and Products Covered

The Toro® Company and its affiliate, Toro Warranty Company, pursuant to an agreement between them, jointly warrant your Toro Commercial Product ("Product") to be free from defects in materials or workmanship for two years or 1500 operational hours\*, whichever occurs first. Where a warrantable condition exists, we will repair the Product at no cost to you including diagnosis, labor, parts, and transportation. This warranty begins on the date the Product is delivered to the original retail purchaser.

Product equipped with hour meter

### Instructions for Obtaining Warranty Service

You are responsible for notifying the Commercial Products Distributor or Authorized Commercial Products Dealer from whom you purchased the Product as soon as you believe a warrantable condition exists.

If you need help locating a Commercial Products Distributor or Authorized Dealer, or if you have questions regarding your warranty rights or responsibilities, you may contact us at:

Toro Commercial Products Service Department

Toro Warranty Company

8111 Lyndale Avenue South

Bloomington, MN 55420-1196

952-888-8801 or 800-982-2740

E-mail: commercial.service@Toro.com

### Owner Responsibilities

As the Product owner, you are responsible for required maintenance and adjustments stated in your operator's manual. Failure to perform required maintenance and adjustments can be grounds for disallowing a warranty claim.

### Items and Conditions Not Covered

Not all product failures or malfunctions that occur during the warranty period are defects in materials or workmanship. This express warranty does not cover the following:

- Product failures which result from the use of non-Toro replacement parts, or from installation and use of add-on, modified, or unapproved accessories
- Product failures which result from failure to perform required maintenance and/or adjustments
- Product failures which result from operating the Product in an abusive, negligent or reckless manner
- Parts subject to consumption through use unless found to be defective. Examples of parts which are consumed, or used

### Countries Other than the United States or Canada

Customers who have purchased Toro products exported from the United States or Canada should contact their Toro Distributor (Dealer) to obtain guarantee policies for your country, province, or state. If for any reason you are dissatisfied with your Distributor's service or have difficulty obtaining guarantee information, contact the Toro importer. If all other remedies fail, you may contact us at Toro Warranty Company.

up, during normal Product operation include, but are not limited to, blades, reels, bedknives, tines, spark plugs, castor wheels, tires, filters, belts, and certain sprayer components such as diaphragms, nozzles, and check valves, etc.

- Failures caused by outside influence. Items considered to be outside influence include, but are not limited to, weather, storage practices, contamination, use of unapproved coolants, lubricants, additives, or chemicals, etc.
- Normal "wear and tear" items. Normal "wear and tear" includes, but is not limited to, damage to seats due to wear or abrasion, worn painted surfaces, scratched decals or windows, etc.

### Parts

Parts scheduled for replacement as required maintenance are warranted for the period of time up to the scheduled replacement time for that part.

Parts replaced under this warranty become the property of Toro. Toro will make the final decision whether to repair any existing part or assembly or replace it. Toro may use factory remanufactured parts rather than new parts for some warranty repairs.

### General Conditions

Repair by an Authorized Toro Distributor or Dealer is your sole remedy under this warranty.

**Neither The Toro® Company nor Toro Warranty Company is liable for indirect, incidental or consequential damages in connection with the use of the Toro Products covered by this warranty, including any cost or expense of providing substitute equipment or service during reasonable periods of malfunction or non-use pending completion of repairs under this warranty. Except for the Emissions warranty referenced below, if applicable, there is no other express warranty. All implied warranties of merchantability and fitness for use are limited to the duration of this express warranty.**

Some states do not allow exclusions of incidental or consequential damages, or limitations on how long an implied warranty lasts, so the above exclusions and limitations may not apply to you.

This warranty gives you specific legal rights, and you may also have other rights which vary from state to state.

Note regarding engine warranty: The Emissions Control System on your Product may be covered by a separate warranty meeting requirements established by the U.S. Environmental Protection Agency (EPA) and/or the California Air Resources Board (CARB). The hour limitations set forth above do not apply to the Emissions Control System Warranty. Refer to the Engine Emission Control Warranty Statement printed in your operator's manual or contained in the engine manufacturer's documentation for details.