



## Z441 Z Master<sup>®</sup> With 52in TURBO FORCE<sup>®</sup> Side Discharge Mower

Model No. 74442 - 270002001 and up.

### Parts Catalog

---

#### Ordering Replacement Parts

To order replacement parts, please supply the part number, the quantity, and the description of each part desired.

#### Understanding Reference Numbers

Each Identified part in an illustration has a reference number. The reference number for a part also appears in the parts list, along with other information about the part.

This catalog uses two special reference number formats, one to indicate parts in a service assembly and another to indicate the quantity of a given part in an illustration.

#### Service Assembly Reference Numbers

Parts in service assemblies have reference numbers in the form a:b. The a represents the reference number of the entire service assembly and the b represents a sequential number unique to each part within the service assembly.

For example, a wheel assembly might be identified by reference number 6, the tire by 6:1, the valve by 6:2, and the wheel by 6:3. When you order the assembly identified by reference number 6, you receive all parts identified by reference numbers 6:1, 6:2, and 6:3. However, you may also order any part individually. Reference numbers of this type appear in illustrations and in part lists.

#### Reference Numbers Indicating Quantity

In an illustration, if a reference number indicates more than one part, the reference number has the form nX y. The n represents the quantity of the part, the X is the multiplication symbol, and the y represents the reference number.

For example, in an illustration, the reference number 2X 37 means that two of the parts identified by reference number 37 are indicated.

# Contents

Description	Page	Description	Page
Front Frame Assembly	..... 3	Deck Connection Assembly	..... 18
Caster Wheel Assembly No. 110-5745	..... 4	Deck Assembly	..... 19
Height-of-Cut-Assembly	..... 5	Idler Assembly	..... 21
Main Frame Assembly	..... 6	Spindle Assembly No. 107-8504	..... 22
Fuel System Assembly	..... 7	Deck Decal Assembly No. 107-1669	..... 23
Parking Brake Assembly	..... 8	Rubber Deflector Assembly No. 108-2792	..... 24
Motion Control Assembly	..... 10	Electrical System Assembly	..... 25
RH Motion Control Assembly No.109-3911	..... 11	Seat and Bracket Assembly	..... 26
LH Motion Control Assembly No. 109-3912	..... 12	Seat Assembly No. 110-0446	..... 27
Hydraulic System Assembly	..... 13	Roll-Over Protection System Assembly	..... 28
Hydraulic Pump Assembly No. 103-1942	..... 15	Roll-Over Protection System Assembly No. 107-8093	..... 29
Pump Idler and Belt Assembly	..... 16	Attachments and Accessories List	..... 30
Engine, Clutch and Muffler Assembly	..... 17		

## Part Description Abbreviations

Part descriptions in this catalog may include the following abbreviations.

AR. .... as required	HYD. .... hydraulic
ASM. .... assembly	LH. .... left hand
BBC. .... blade brake clutch	NI. .... nylon insert
CARR. .... carriage	NPTF. .... national pipe thread fine
DEG. .... degrees	PFH. .... phillips flat head
EXT. .... external	PPH. .... phillips pan head
FH. .... flat head	PPHTF. .... phillips pan head thread forming
GA. .... gauge	PRH. .... phillips round head
HD. .... heavy-duty	PTH. .... phillips truss head
HF. .... hex flange	PTO. .... power-take-off
HH. .... hex head	RH. .... right hand
HHF. .... hex head flange	ROPS. .... roll-over protection system
HHFTF. .... hex head flange thread forming	SFH. .... slotted fillister head
HJ. .... hex jam	SHH. .... slotted hex head
HLH. .... hex lag head	SHWH. .... slotted hex washer head
HOC. .... height-of-cut	SPH. .... slotted pan head
HSBH. .... hex socket button head	SQH. .... square head
HSFH. .... hex socket flat head	SRH. .... slotted round head
HSH. .... hex socket head	STD. .... standard
HWH. .... hex washer head	TAP. .... self tapping
HWHTF. .... hex washer head thread forming	TTH. .... torx truss head

## Footnotes

- |                      |                                          |
|----------------------|------------------------------------------|
| ❶ Not illustrated    | ❷ Not serviced separately                |
| ❸ Optional Equipment | ❹ Obtain from your local Kawasaki dealer |

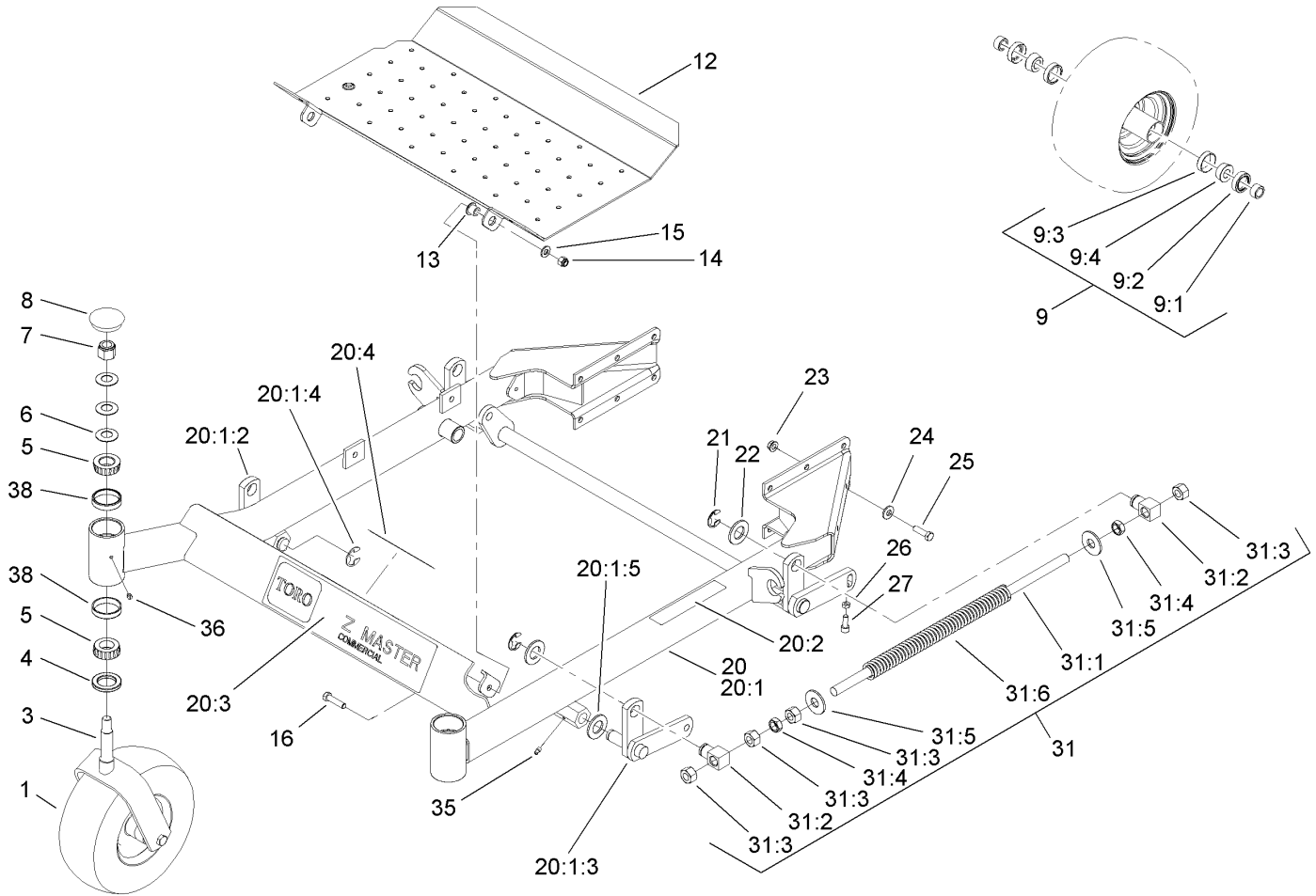

## Front Frame Assembly

Ref	Part No.	Qty.	Description
1	110-5745	2	Semi Pnuematic Wheel ASM
3	1-632511-01	2	Caster
4	1-543511	2	Seal-Grease
5	254-94	4	Bearing-Cone, Tapered
6	1-633508	6	Washer-Bellville
7	3296-51	2	Nut-Lock, NI
8	103-4882	2	Cap-Grease
9	110-8837	1	Caster Wheel Bearing Kit
9:1	1-633581	2	Spacer-Bearing
9:2	1-633580	2	Seal-Bearing
9:3	1-633584	2	Bearing-Cup
9:4	1-633585	2	Bearing-Cone, Taper
12	108-5007-03	1	Floor Pan
13	86-2180	2	Bushing-Flange
14	3296-39	2	Nut-Lock, NI
15	3256-24	2	Washer-Flat
16	323-8	2	Screw-HH
20	108-5022	1	Front Frame ASM
20:1		1	Frame-Front
20:1:2	99-3872	1	RH Lift Arm ASM
20:1:3	99-3871	1	LH Lift Arm ASM
20:1:4	32151-103	2	Ring-Snap
20:1:5	3256-29	2	Washer-Flat
20:2	1-633818	1	Decal-Warning

Ref	Part No.	Qty.	Description
20:3	106-7451	1	Decal
20:4	107-2112	1	Decal-Warning
21	32151-103	4	Ring-Snap
22	3256-29	4	Washer-Flat
23	3290-357	12	Nut-HHF, Whiz
24	98-5975	12	Washer-Belleville
25	323-7	12	Screw-HH
26	3218-2	2	Nut-Jam
27	3274-18	2	Screw-HSH
31	1-634439	2	Front Frame Spring ASM
31:1	1-633096	1	Rod-Lift, Deck
31:2	1-633441	2	Swivel-Deck Mount, Rear
31:3	3217-11	4	Nut-Hex
31:4	3218-6	2	Nut-Jam
31:5	3256-7	2	Washer-Flat
31:6	1-633064	1	Spring-Support, Deck
35	302-19	4	Fitting-Grease
36	1-811010	2	Plug
38	254-72	4	Bearing-Cup, Tapered



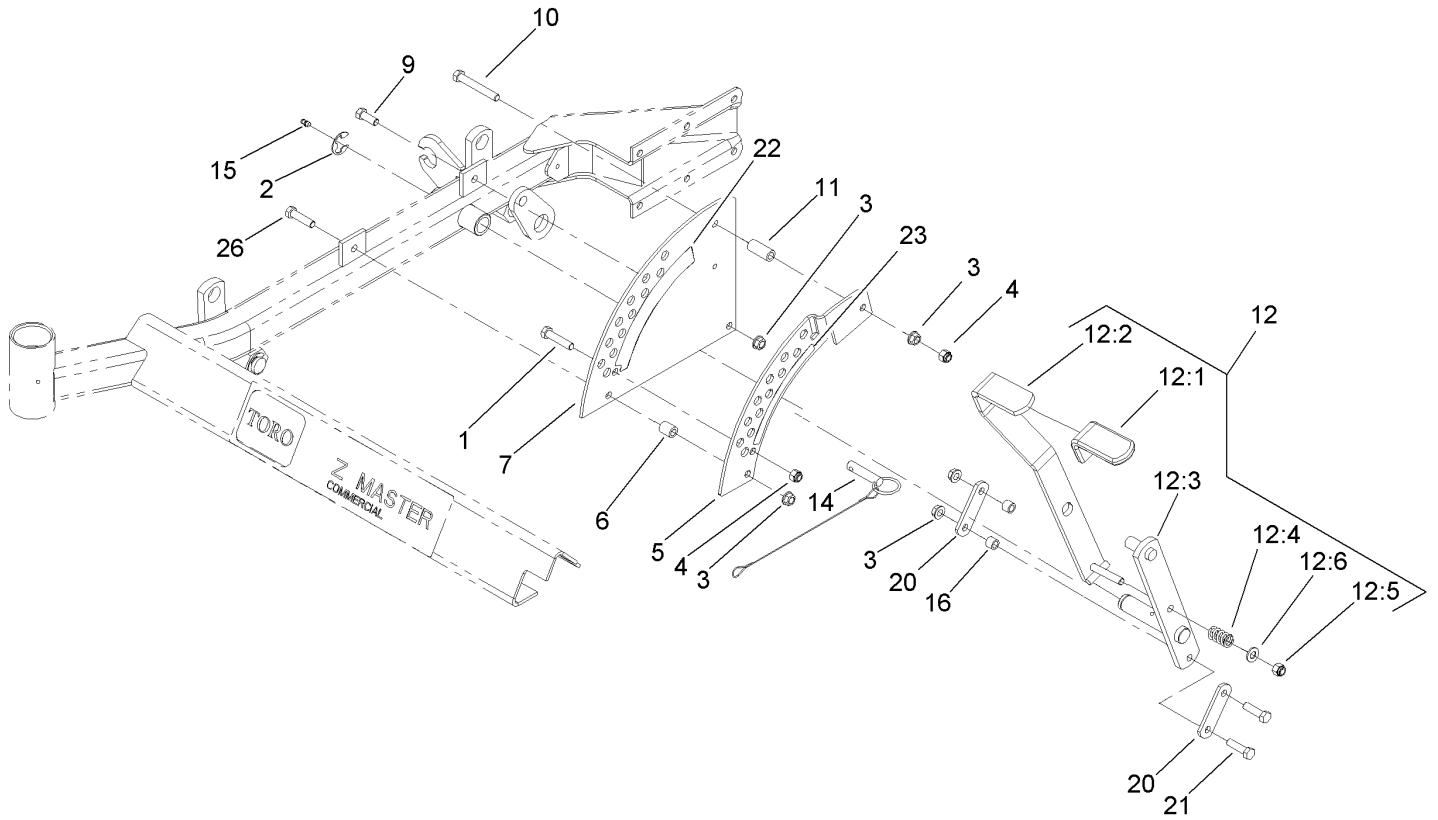

## Height-of-Cut-Assembly

Ref	Part No.	Qty.	Description
1	323-9	1	Screw-HH
2	32151-103	1	Ring-Snap
3	3290-357	5	Nut-HHF, Whiz
4	3296-39	2	Nut-Lock, NI
5	108-7755-01	1	Plate-Lift, Deck
6	1-633080	1	Bushing-Lever, Lift
7	1-653230-01	1	Plate-Lift, Deck
9	323-6	1	Screw-HH
10	323-13	1	Screw-HH
11	1-633082	1	Bushing-Lever, Lift
12	110-5870	1	Deck Lift Handle ASM
12:1	1-633295	1	Grip-Lever, Lift
12:2	103-2078	1	Handle-Lift
12:3	106-6598	1	Lift Arm ASM
12:4	1-633325	1	Spring-Compression
12:5	3296-39	1	Nut-Lock, NI
12:6	3256-24	1	Washer-Flat
14	106-9951	1	Hitch Pin ASM
15	302-19	1	Fitting-Grease
16	103-1918	2	Bushing
20	1-633068	2	Arm-Lift, Deck
21	323-29	2	Screw-HH
22	108-1051	1	Decal-Deck Height, Outer
23	108-1050	1	Decal-Deck Height, Inner

Ref	Part No.	Qty.	Description
26	323-8	1	Screw-HH



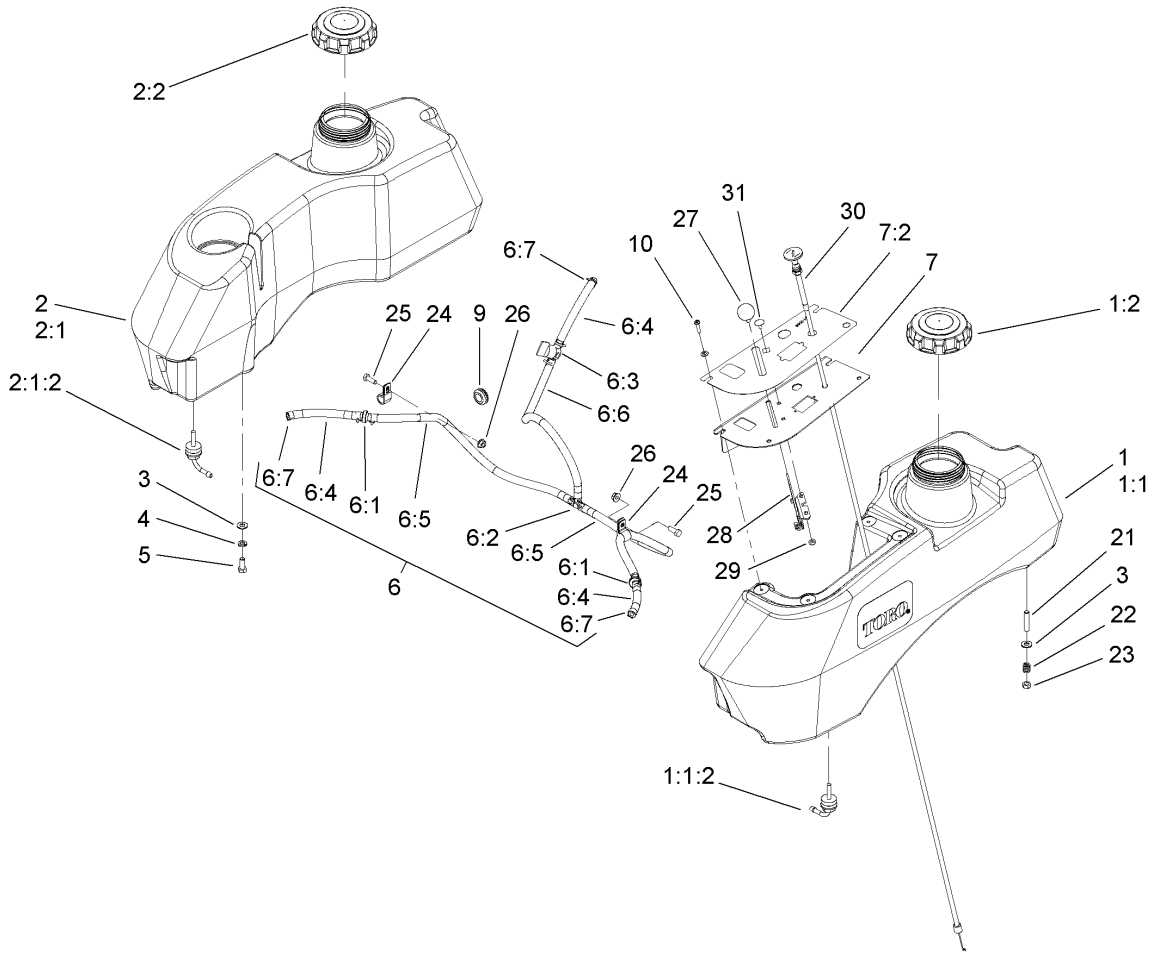

## Fuel System Assembly

Ref	Part No.	Qty.	Description
1	110-4165	1	LH Fuel Tank Service Kit
②1:1		1	LH Fuel Tank ASM
1:1:2	103-2605	1	Fitting-Fuel, Bulkhead
1:2	109-0346	1	Cap-Fuel, Gas
2	105-3639	1	RH Fuel Tank Service Kit
②2:1		1	RH Fuel Tank ASM
2:1:2	103-2605	1	Fitting-Fuel, Bulkhead
2:2	109-0346	1	Cap-Fuel, Gas
3	3256-23	8	Washer-Flat
4	1-805005	4	Washer-Lock
5	322-3	4	Screw-HH
②6		1	Fuel Line ASM
6:1	99-5000	2	Valve-Check, Fuel
6:2	99-5005	1	Fitting-Tee, Barbed
6:3	1-603770	1	Valve-Fuel
6:4	109-0678	3	Hose-Fuel
6:5	110-5701	2	Hose-Fuel
6:6	109-0297	1	Hose-Fuel
6:7	1-303077	12	Clamp
7	107-2149	1	Control Panel ASM
7:2	110-0439	1	Decal-Panel, Control
9	1-543296	2	Grommet
10	109-2661	4	Screw-PPH
21	1-633023	4	Stud

Ref	Part No.	Qty.	Description
22	1-633349	4	Spring-Tank, Fuel
23	3296-47	4	Nut-Lock, NI
24	1-513762	2	Clip-Loom
25	321-4	2	Screw-HH
26	32128-33	2	Nut-HF
27	1-513592	1	Knob-Ball
28	1-633696	1	Throttle Cable ASM
29	3296-2	2	Nut-Lock
30	106-9962	1	Control-Choke, Push / Pull
31	1-807513	2	Bolt-CARR

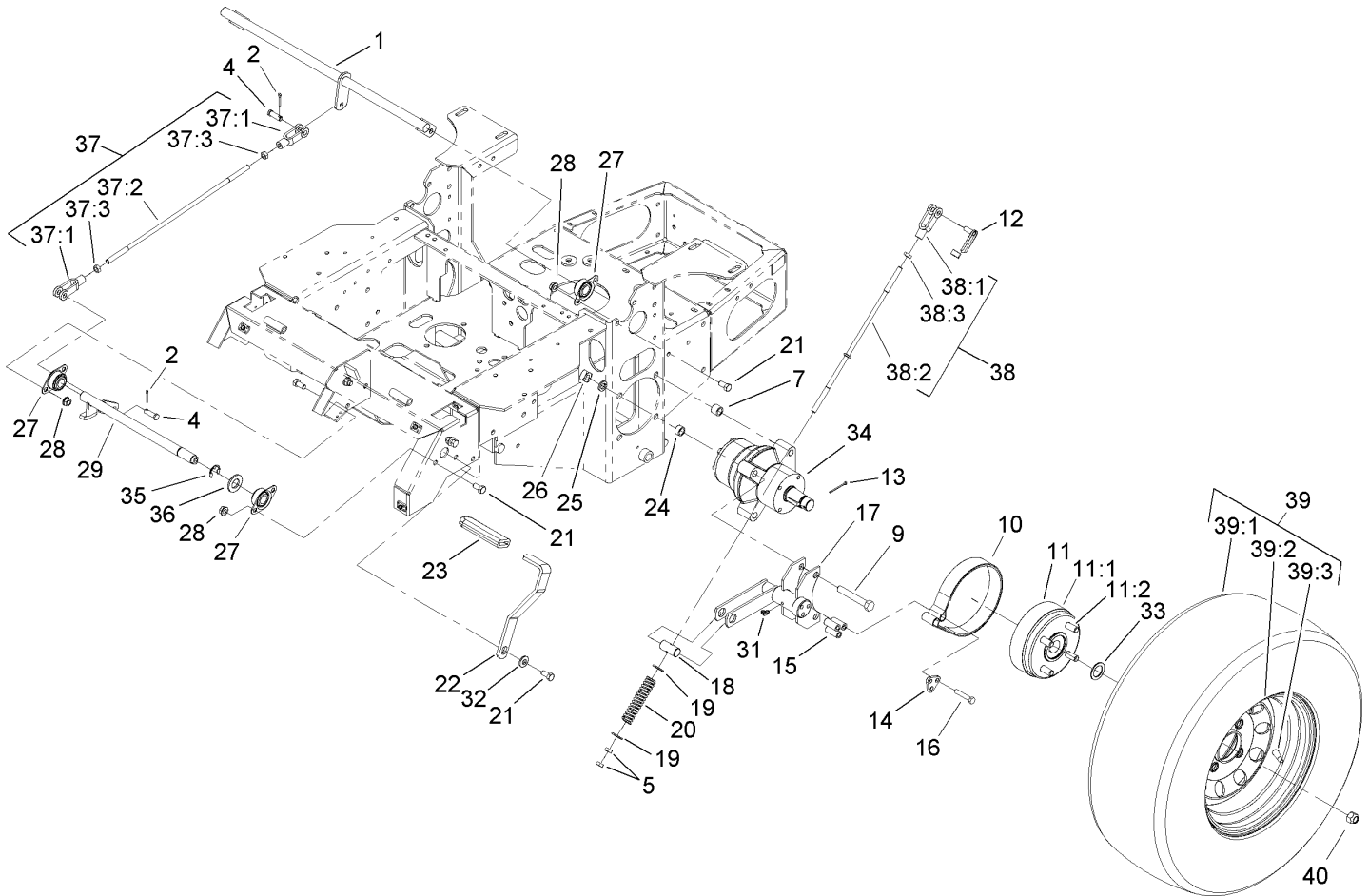

## Parking Brake Assembly

Ref	Part No.	Qty.	Description
1	1-652073-03	1	Crank-Brake, Park
2	3272-10	2	Pin-Cotter
4	1-808285	2	Pin-Clevis
5	3219-3	4	Nut-Hex
7	1-653068	4	Spacer-Wheel
9	325-13	8	Screw-HH
10	103-0355	2	Band-Brake
11		2	Hub And Wheel ASM
11:1	103-0589	1	Wheel Hub ASM
11:2	1-633926	4	Stud-Wheel
12	103-2399	2	Pin-Spring, Clevis
13	1-806800	2	Pin-Cotter
14	103-0374	2	Retainer-Band, Brake
15	103-0384	6	Spacer
16	322-9	6	Screw-HH
17	103-0352-03	2	Bracket-Brake
18	1-633144	2	Pin-Trunion
19	3256-4	4	Washer-Flat
20	1-633454	2	Spring-Brake
21	323-4	9	Screw-HH
22	1-653074-03	1	Handle-Brake, Park
23	1-633268	1	Grip-Lever, Brake
24	1-653069	4	Spacer-Wheel
25	3253-7	8	Washer-Lock

Ref	Part No.	Qty.	Description
26	103-0131	8	Nut-Square
27	1-633102	4	Bearing-Flange, Side
28	3290-357	8	Nut-HHF, Whiz
29	103-3116	1	Shaft-Brake, Parking
31	1481	2	Fitting-Grease
32	98-5975	1	Washer-Belleville
33	1-523157	2	Washer-Spacer
34	103-5333	2	Motor-Wheel
●34:1	109-5965	1	Wheel Motor Seal Kit
●34:2	109-5966	1	Wheel Motor Seal Kit
35	32151-48	1	E-Ring
36	3256-28	1	Washer-Flat
37	103-4328	1	Brake Rod ASM
37:1	1-633131	2	Yoke-Linkage, Brake
37:2	1-653061	1	Linkage-Handle, Brake
37:3	3219-3	2	Nut-Hex
38	103-4329	2	Brake Rod ASM
38:1	1-633131	1	Yoke-Linkage, Brake
38:2	103-0356	1	Rod-Brake
38:3	3219-3	1	Nut-Hex
39	1-653159	2	Wheel And Tire ASM
39:1	1-653160	1	Tire
39:2	1-653161	1	Wheel
39:3	232-27	1	Stem-Valve



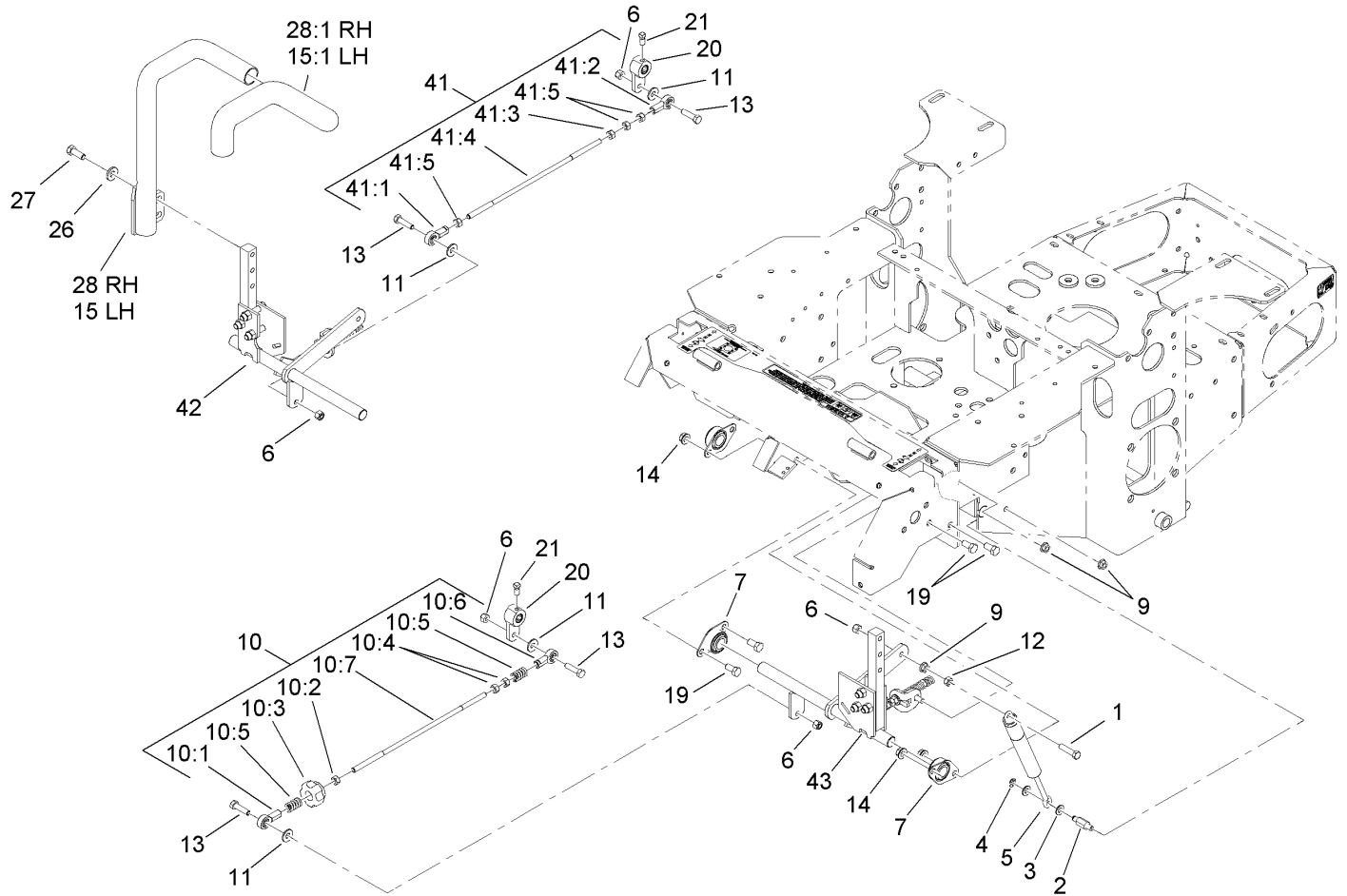

## Motion Control Assembly

Ref	Part No.	Qty.	Description
1	1-403180	2	Screw-HH
2	103-4101	2	Pin-Damper
3	3256-23	4	Washer-Flat
4	32120-35	2	Ring-Retaining, EXT
5	109-2339	2	Damper-Control, Motion
6	3296-29	6	Nut-Lock, NI
7	1-633102	4	Bearing-Flange, Side
9	32128-20	10	Nut-HF
10	103-4326	1	Tracking Rod ASM
10:1	1-543017	1	Balljoint-RH
10:2	3219-2	1	Nut-Hex
10:3	103-3060	1	Knob-Tracking
10:4	1-804524	2	Nut
10:5	1-323245	2	Spring-Compression
10:6	1-633152	1	Balljoint-LH
10:7	103-3066	1	Link-Rod, Tracking
11	3256-3	4	Washer-Flat
12	3217-6	2	Nut-Hex
13	322-6	4	Screw-HH
14	3290-357	6	Nut-HHF, Whiz
15	108-7238	1	LH Lever ASM
15:1	106-9987	1	Grip-Control, Motion
19	323-4	6	Screw-HH
20	103-3717	2	Arm-Control

Ref	Part No.	Qty.	Description
21	1-803022	2	Screw-Set
26	98-5975	4	Washer-Belleville
27	323-6	4	Screw-HH
28	108-7237	1	RH Lever ASM
28:1	106-9987	1	Grip-Control, Motion
41	103-4327	1	Tracking ASM
41:1	1-543017	1	Balljoint-RH
41:2	1-633152	1	Balljoint-LH
41:3	1-804524	1	Nut
41:4	103-3066	1	Link-Rod, Tracking
41:5	3219-2	3	Nut-Hex
42	109-3911	1	RH Motion Control ASM
43	109-3912	1	LH Motion Control ASM

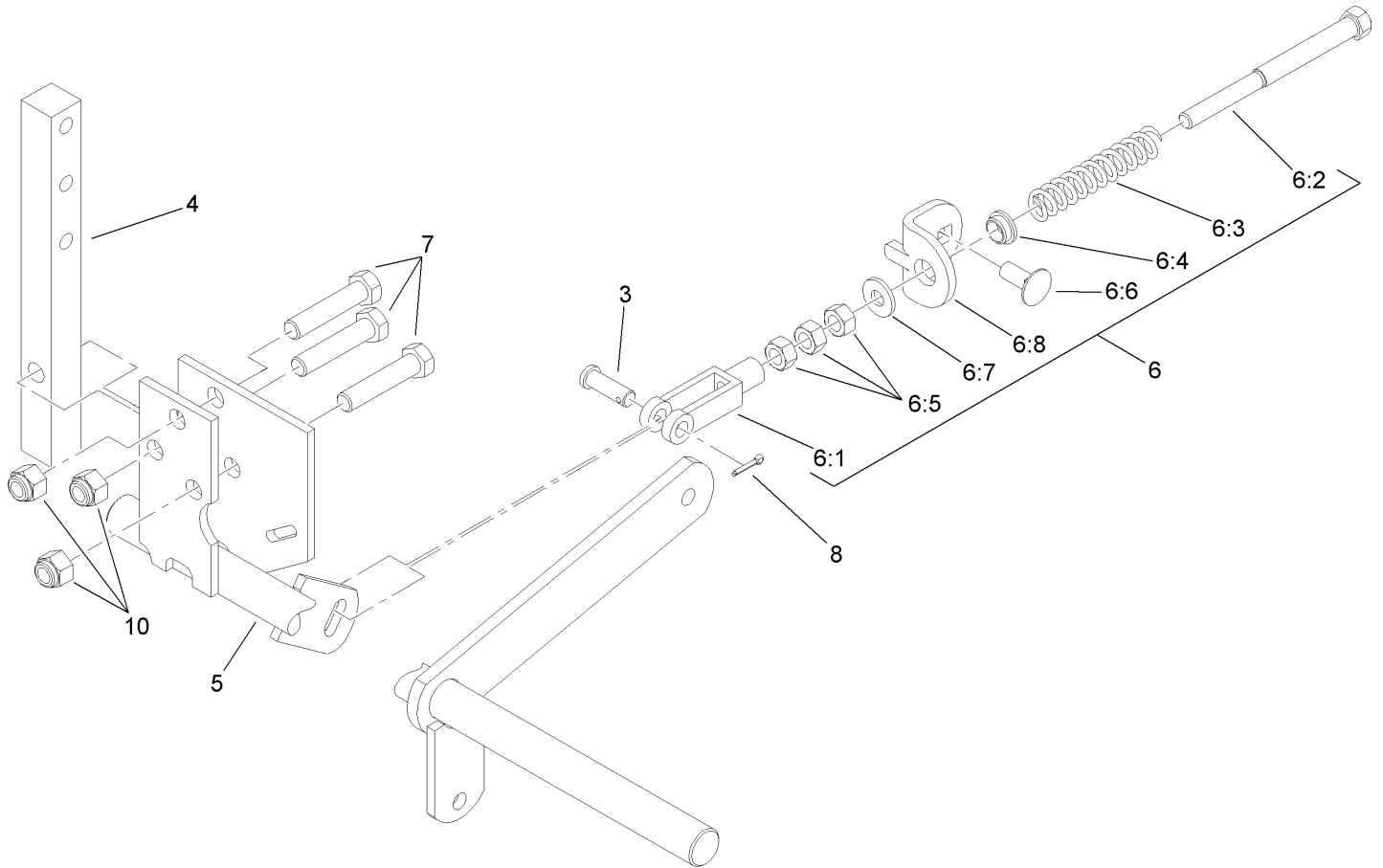

## RH Motion Control Assembly No.109-3911

Ref	Part No.	Qty.	Description
3	1-808280	1	Pin-Clevis
4	103-0407	1	Arm-Shaft, Control
5	103-4773	1	Control-Motion, RH
6	109-3903	1	Neutral Return ASM
6:1	1-303105	1	Yoke-Adjustable
6:2	1-603737	1	Bolt-Return, Neutral
6:3	1-603807	1	Spring-Return, Neutral
6:4	109-3769	1	Bushing-Nylon, Flanged
6:5	3219-2	3	Nut-Hex
6:6	3230-23	1	Screw-CARR
6:7	3256-2	1	Washer-Flat
6:8	109-3908	1	Tab-Adjustment
7	323-9	3	Screw-HH
8	3272-5	1	Pin-Cotter
10	3296-39	3	Nut-Lock, NI

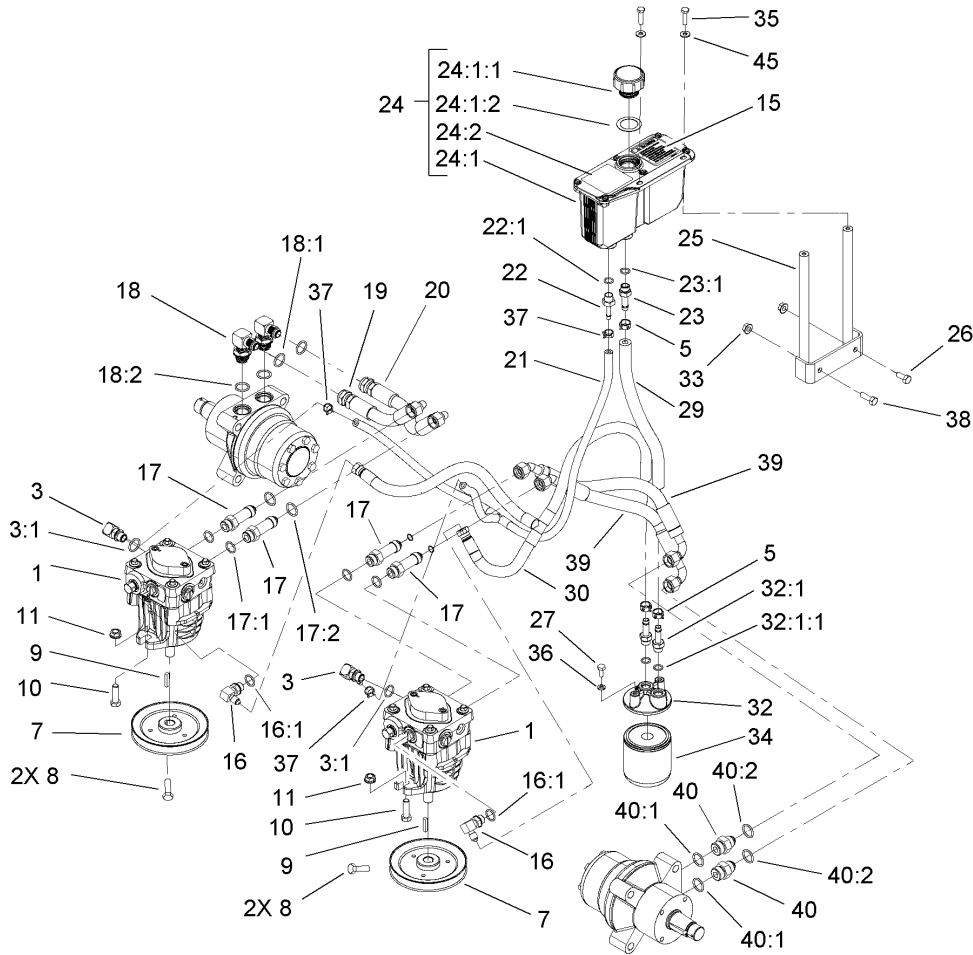

## Hydraulic System Assembly

Ref	Part No.	Qty.	Description
1	103-1942	2	Pump-HYD
3	103-1799	2	Elbow-90 DEG
3:1	237-42	1	O-Ring
5	103-1988	3	Clamp-Hose
7	1-653156	2	Pulley
8	1-803050	4	Screw-Set
9	1-807272	2	Key
10	323-7	4	Screw-HH
11	3290-357	4	Nut-HHF, Whiz
15	103-2644	1	Decal-Exhaust
16	103-1802	2	Fitting-HYD, 90 DEG
16:1	1-603921	1	O-Ring
17	103-1940	4	Adapter-HYD, Straight
17:1	237-79	1	O-Ring
17:2	1-603992	1	O-Ring
18	1-633605	2	Fitting-HYD, 90 DEG
18:1	1-603992	1	O-Ring
18:2	237-80	1	O-Ring
19	1-653186	1	Hose-Front
20	1-653187	1	Hose-Rear, RH
21	103-2357	1	HYD Hose ASM
22	103-1801	1	Adapter-Straight
22:1	237-42	1	O-Ring
23	103-1912	1	Adapter-Straight

Ref	Part No.	Qty.	Description
23:1	237-42	1	O-Ring
24	103-1947	1	HYD Reservoir ASM
24:1		1	Reservoir-HYD
24:1:1	103-1948	1	Cap-Reservoir, HYD
24:1:2	103-1949	1	Gasket-Cap
24:2	1-523552	1	Decal-Tank, HYD
25	103-3071-03	1	Stand-Reservoir
26	322-3	1	Screw-HH
27	321-3	2	Screw-HH
29	103-3077	1	HYD Hose ASM
30	103-2930	1	HYD Hose ASM
32	103-2889	1	Filter Head ASM
32:1	103-1912	2	Adapter-Straight
32:1:1	237-42	1	O-Ring
33	32128-20	2	Nut-HF
34	1-633750	1	Filter-Oil, HYD
34	1-633752	1	Filter-HYD, Winter
35	321-6	2	Screw-HH
36	1-805004	2	Washer-Lock
37	103-1716	3	Clamp-Hose
38	322-5	1	Screw-HH
39	103-3809	2	Hose-LH
40	1-603991	2	Fitting-Straight
40:1	237-80	1	O-Ring

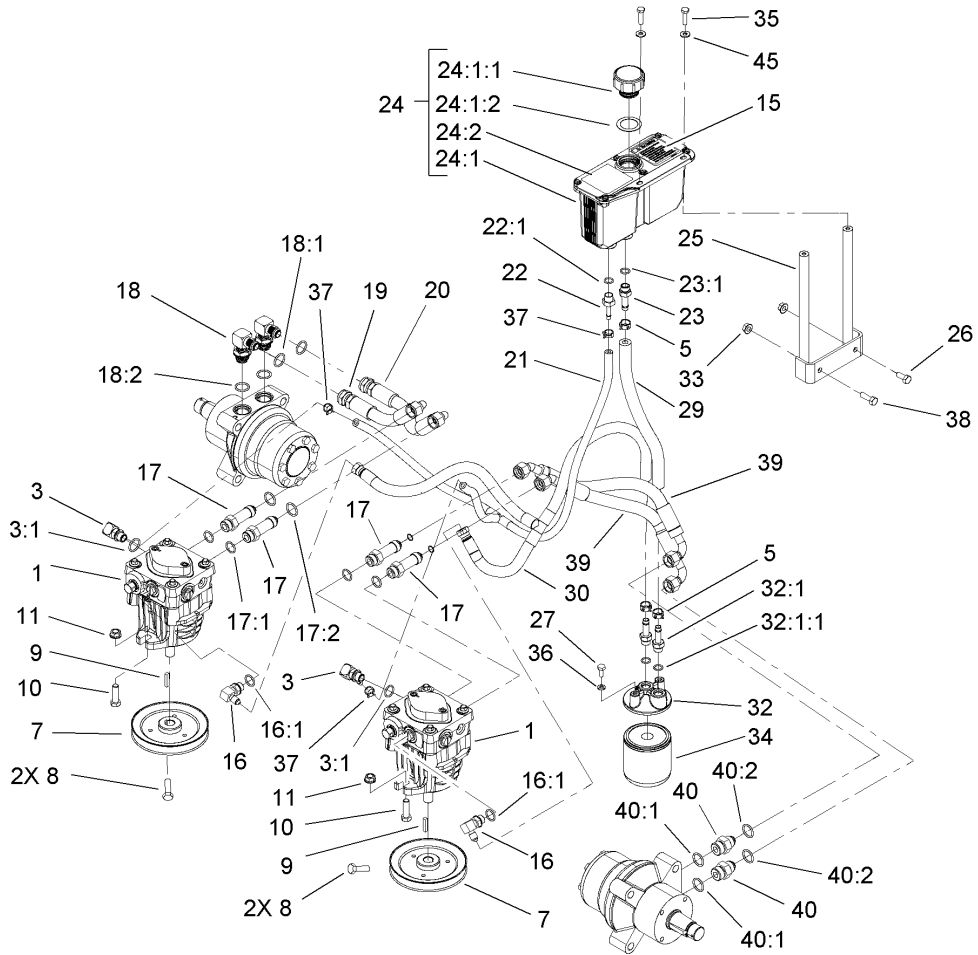

## Hydraulic System Assembly (continued)

Ref	Part No.	Qty.	Description
40:2	1-603992	1	O-Ring
45	3256-22	2	Washer-Flat

--	--	--	--



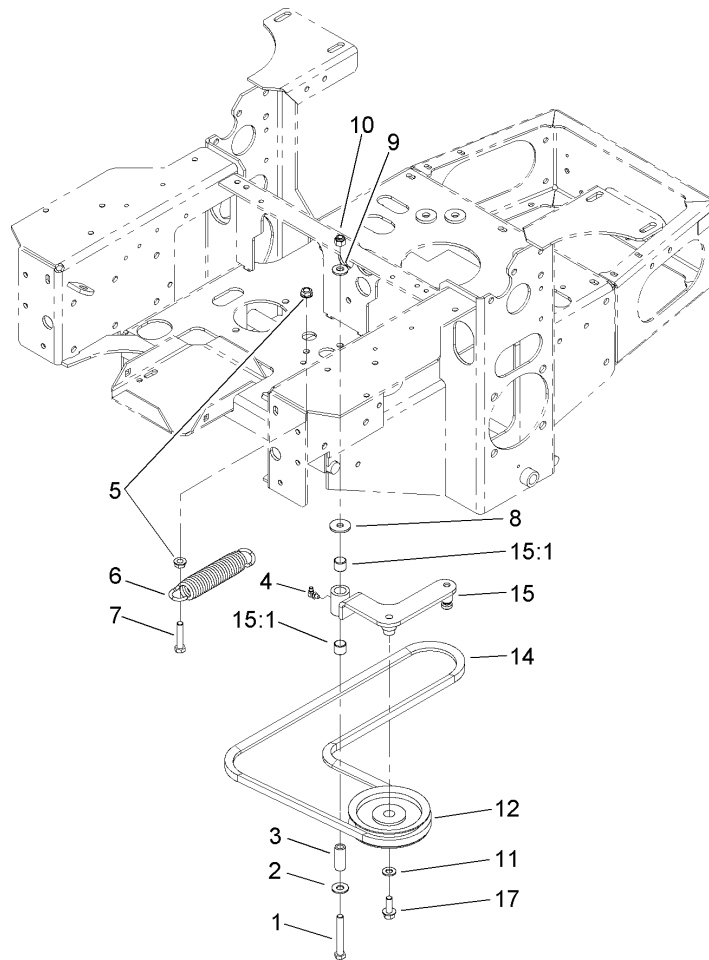

### Pump Idler and Belt Assembly

Ref	Part No.	Qty.	Description
1	323-13	1	Screw-HH
2	3256-4	1	Washer-Flat
3	1-603044	1	Bushing
4	302-40	1	Fitting-Grease
5	3290-357	2	Nut-HHF, Whiz
6	103-4480	1	Spring-Extension
7	323-9	1	Screw-HH
8	63-8410	1	Washer
9	98-5975	1	Washer-Belleville
10	3296-39	1	Nut-Lock, NI
11	3256-24	1	Washer-Flat
12	1-603843	1	Pulley-Idler
14	107-3960	1	Belt
15	103-4482	1	Idler Arm ASM
15:1	103-4681	2	Sleeve-Bearing
17	3234-11	1	Screw-HHF

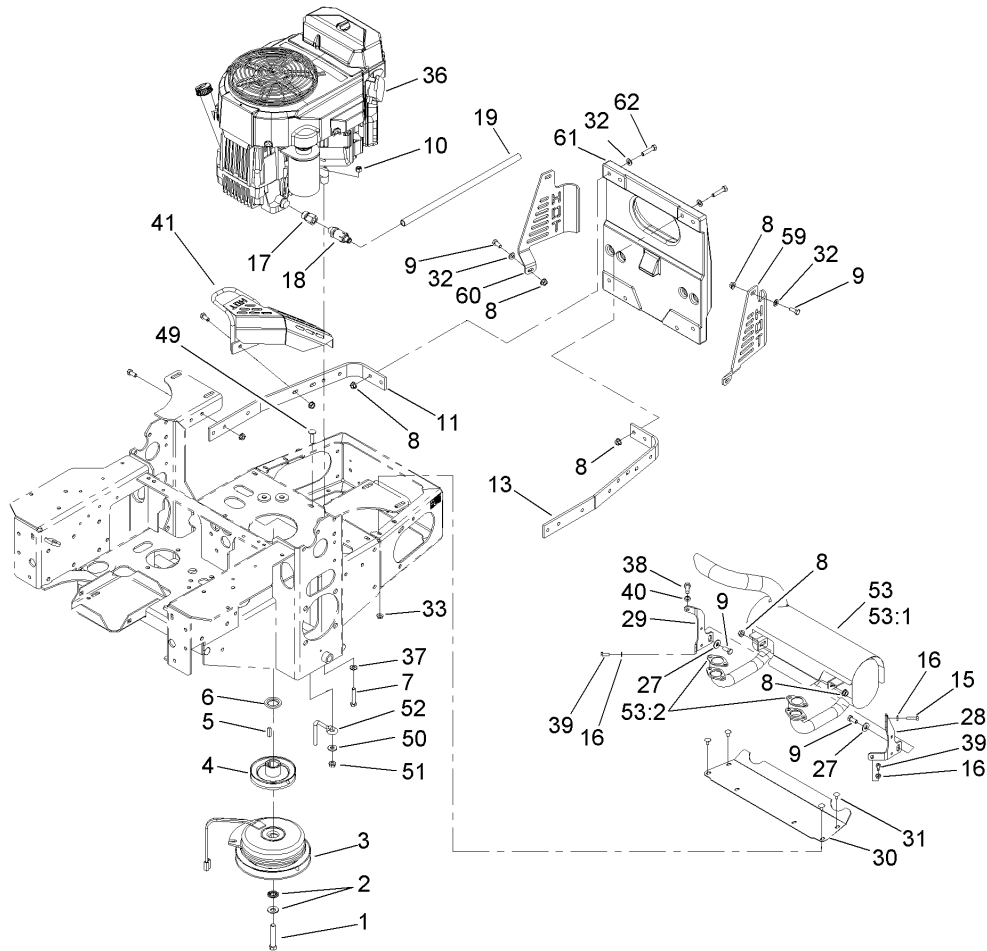

## Engine, Clutch and Muffler Assembly

Ref	Part No.	Qty.	Description
1	3212-12	1	Screw-HH
2	1-603610	2	Washer-Spring
3	109-2916	1	Clutch
4	103-3913	1	Pulley
5	1-807259	1	Key
6	103-2308	1	Spacer-Crankshaft
7	322-9	4	Screw-HH
8	32128-20	29	Nut-HF
9	322-3	15	Screw-HH
10	3296-29	4	Nut-Lock, NI
11	103-3078-03	1	Strap-Guard, RH
13	103-3164-03	1	Strap-Guard, LH
15	33113-025	1	Screw-HH
16	1-805004	3	Washer-Lock
17	103-1966	1	Adapter
18	92-6877	1	Valve-Drain, Oil
19	106-7022	1	Tube-Drain, Oil
27	3256-3	3	Washer-Flat
28	103-2993-03	1	Bracket-Muffler, LH
29	103-2994-03	1	Bracket-Muffler, RH
30	103-2740-03	1	Deflector-Short
31	3229-10	4	Screw-CARR
32	3256-23	12	Washer-Flat
33	32128-33	4	Nut-HF

Ref	Part No.	Qty.	Description
36		1	Engine-Kawasaki, FH641V-As19
37	1-303334	4	Washer-Spring
38	33114-025	1	Screw-HH
39	33113-016	2	Screw-HH
40	1-805005	1	Washer-Lock
41	103-3218-03	1	Guard-Tailpipe
49	3230-3	1	Screw-CARR
50	3256-3	1	Washer-Flat
51	32128-20	1	Nut-HF
52	108-1058	1	Rod-Belt
53	103-3427	1	Muffler Kit
53:1	103-2761	1	Muffler
53:2	1-653313	2	Gasket-Exhaust
59	103-3287-03	1	Guard-Muffler, LH
60	103-3288-03	1	Guard-Muffler, RH
61	107-8421-03	1	Weight-Notched, 60 Lb
62	322-7	8	Screw-HH

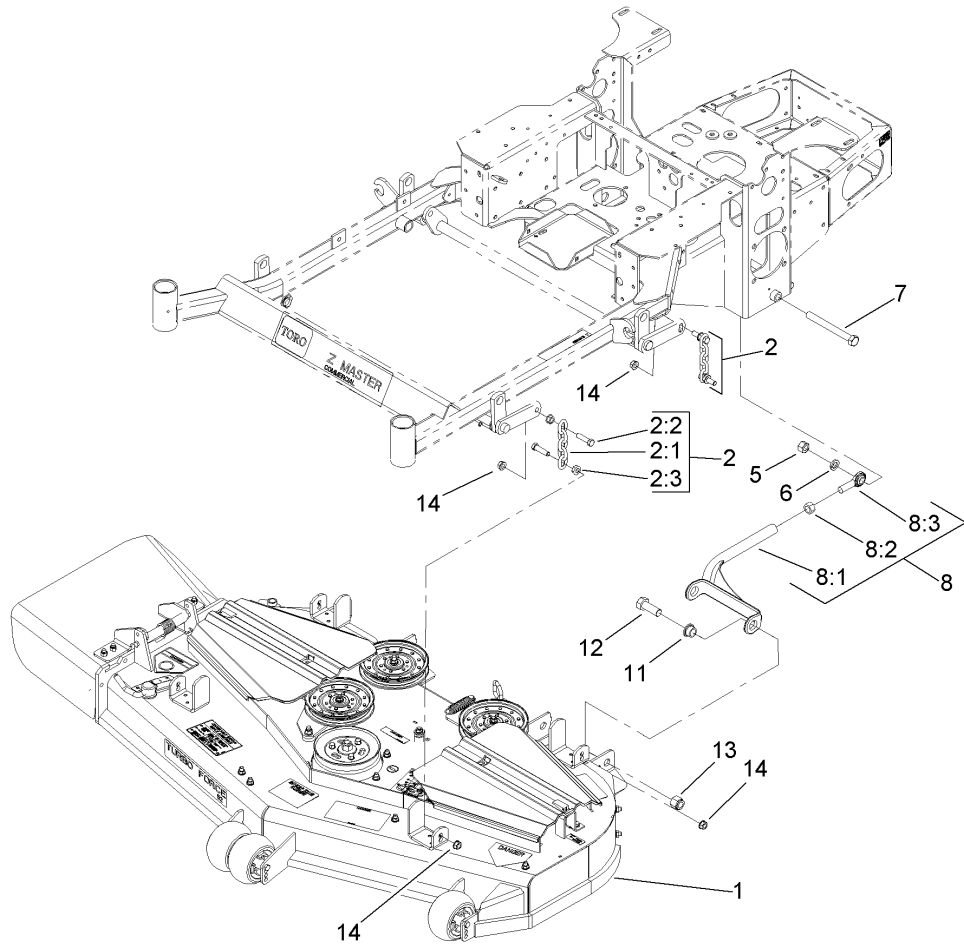

## Deck Connection Assembly

Ref	Part No.	Qty.	Description
1	107-1670	1	Deck ASM
2	103-9792	4	Deck Chain ASM
2:1	1-633447	1	Chain-Lift, Deck
2:2	103-1898	2	Screw-HH
2:3	32128-37	2	Nut-HF
5	3217-11	2	Nut-Hex
6	3253-8	2	Washer-Lock
7	1-800344	2	Screw
8	108-7768	2	Strut ASM
8:1	108-7753-03	1	Strut-Deck
8:2	3219-6	1	Nut-Hex
8:3	1-633029	1	Balljoint-Spherical
11	93-2877	4	Bushing
12	328-24	4	Screw-HH
13	3296-51	4	Nut-Lock, NI
14	32128-37	8	Nut-HF

--	--	--	--

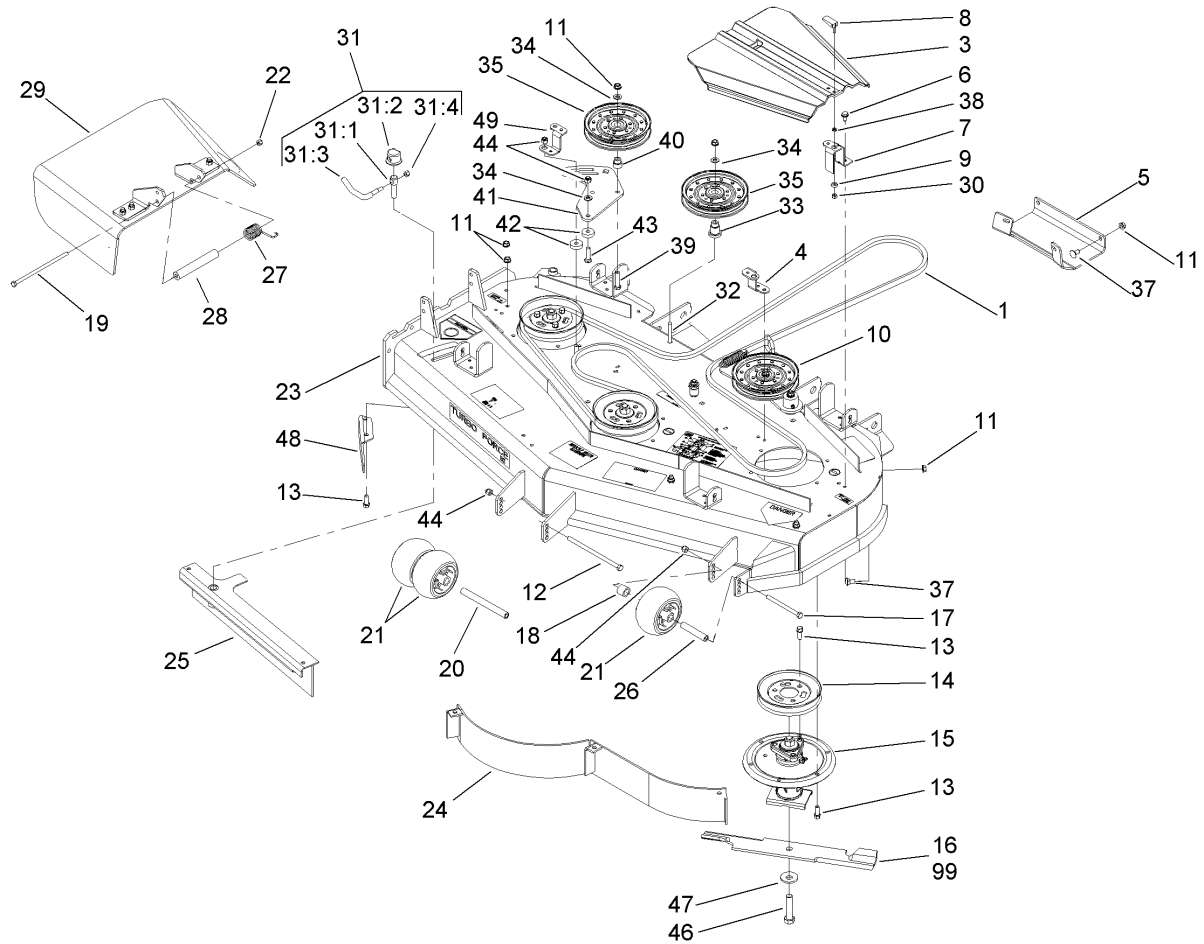

## Deck Assembly

Ref	Part No.	Qty.	Description
1	106-7369	1	Belt-V
3	107-8536	2	Cover-Belt
4	108-2177-01	1	Bracket-Cover, Tall
5	106-7358-01	1	Plate-Skid
6	32144-70	3	Screw-HWHTF
7	108-4121-01	2	Bracket-Cover
8	106-6777	2	Handle-Latch, Swell
9	106-6778	2	Bushing-Latch, Swell
10		1	Spring Idler ASM
11	3290-357	36	Nut-HHF, Whiz
12	323-28	1	Screw-HH
13	92-1624	33	Screw
14	107-1683	3	Pulley
15	107-8504	3	Spindle ASM
16	105-7781-03	3	Blade-Hi Flow
17	323-23	1	Screw-HH
18	98-7913	1	Tube-Spacer
19	322-50	1	Screw-HH
20	98-5967	1	Spacer-Wheel
21	1-603299	3	Roller-Scalp, Anti
22	3296-29	1	Nut-Lock, NI
23	107-1669	1	Deck ASM
24	105-7754-01	1	Baffle ASM
25	105-7755-01	1	Baffle ASM

Ref	Part No.	Qty.	Description
26	98-7912	1	Tube-Spanner
27	108-4052	1	Spring-Torsion
28	105-4622	1	Spacer
29	108-2792	1	Rubber Deflector ASM
30	1-804254	2	Nut
31	107-1664	1	Lever ASM
31:1	106-3239	1	Screw-Lock
31:2	107-1644	1	Cap-Lock
31:3	106-3241	1	Lever-Lock
31:4	3296-29	1	Nut-Lock, NI
32	3231-31	1	Screw-CARR
33	106-3214	1	Mount-Pulley
34	3256-24	3	Washer-Flat
35	1-633109	2	Idler-Flat
37	3231-1	10	Screw-CARR
38	99-3058	2	Washer
39	323-9	1	Screw-HH
40	1-603496	1	Bushing-Idler
41	107-8516-01	1	Plate-Idler
42	105-7788	2	Spacer
43	3231-4	2	Screw-CARR
44	3296-39	6	Nut-Lock, NI
46	103-0862	3	Screw-Cap
47	103-0865	3	Washer-Blade Bolt, Heavy











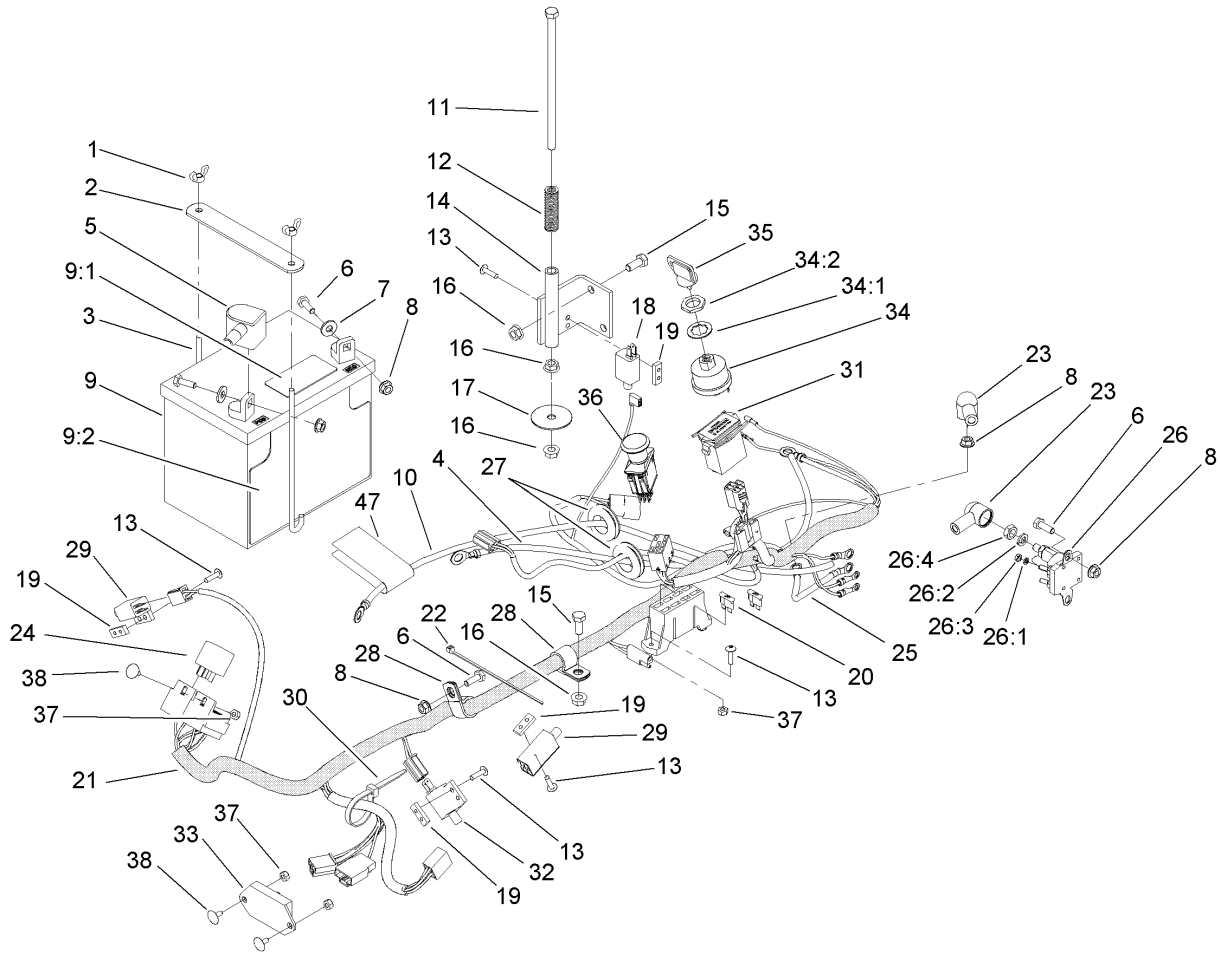

## Electrical System Assembly

Ref	Part No.	Qty.	Description
1	1-543792	2	Wingnut
2	107-9277-03	1	Strap-Holddown, Battery
3	1-633651	2	Bolt-Holddown
4	103-0705	1	Cable-Ground, Negative
5	1-543391	1	Insulator-Battery
6	321-4	5	Screw-HH
7	3256-2	2	Washer-Flat
8	32128-33	6	Nut-HF
9	105-1692	1	Battery
9:1	104-4163	1	Decal-Battery
9:2	104-4164	1	Decal-Battery
10	103-0707	1	Cable-Battery, Positive
11	1-800282	1	Screw-HH
12	1-523415	1	Spring-Switch, Seat
13	1-803075	10	Screw-Head, Truss
14	1-652072-03	1	Bracket-Switch, Seat
15	322-3	3	Screw-HH
16	32128-20	5	Nut-HF
17	1-653036	1	Washer
18	1-513152	1	Switch-Closed, Normally
19	1-633181	4	Plate-Tapped
20	1-816001	2	Fuse-Blade Type, 20 Amp
21	110-0318	1	Harness-Electrical
22	1-303287	3	Tie-Plastic

Ref	Part No.	Qty.	Description
23	1-543393	3	Insulator-Solenoid
24	1-643275	2	Relay
25	1-633306	1	Cable-Starter, Positive
26	1-513075	1	Switch-Solenoid
26:1	3253-17	2	Washer-Lock
26:2	3253-4	2	Washer-Lock
26:3	3219-14	2	Nut-Hex
26:4	3220-2	2	Nut-Jam
27	1-543286	2	Grommet
28	1-633396	2	Clip-Loom
29	1-513051	2	Switch-Open, Normally
30	1-303335	4	Tie-Plastic
31	1-513374	1	Meter-Hour
32	1-633111	1	Switch
33	100-6186	1	Module-Delay, Seat
34	104-2541	1	Switch-Key
34:1	218-461	1	Nut-HH
34:2	3254-5	1	Washer-Tooth
35	63-8360	2	Key-Ignition
36	103-5221	1	Switch-PTO
37	3296-2	6	Nut-Lock
38	1-807513	4	Bolt-CARR
47	107-9309	1	Decal-Instructions, Charging







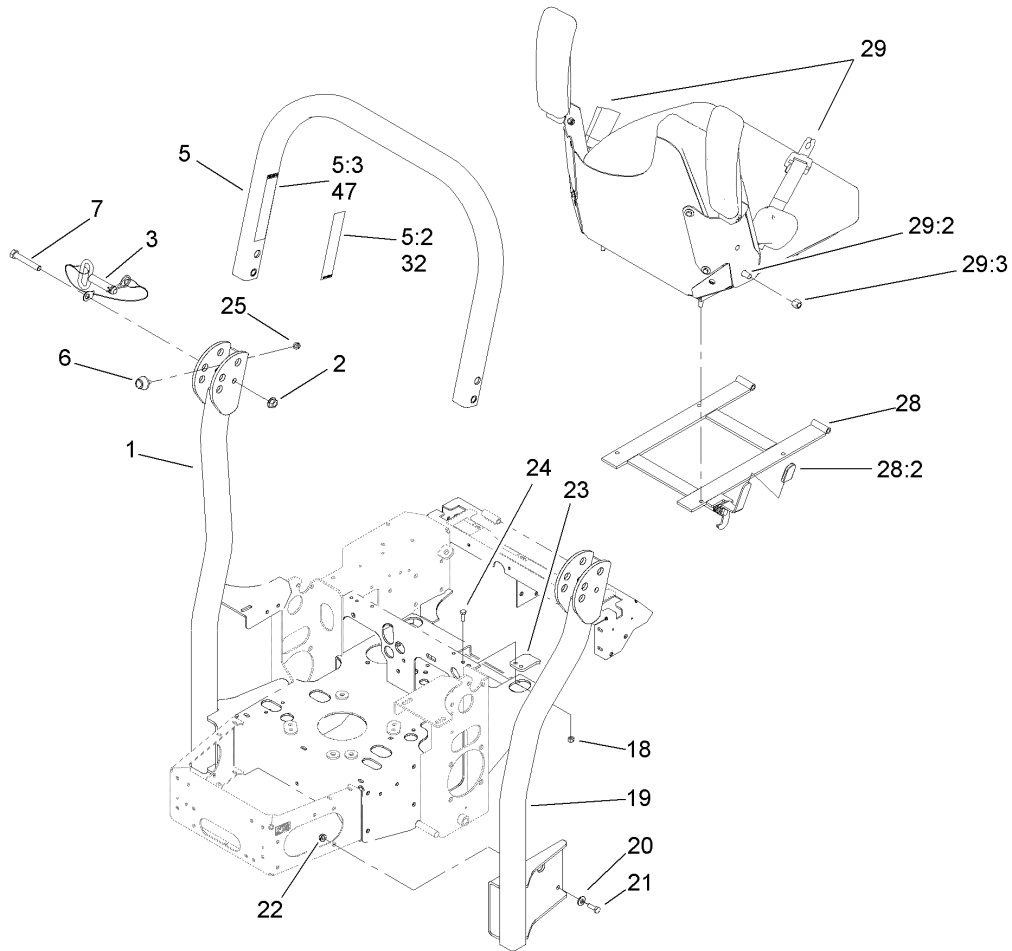

## Roll-Over Protection System Assembly No. 107-8093

Ref	Part No.	Qty.	Description				
②1		1	LH Tube Support ASM				
2	32128-23	2	Nut-HF				
3	103-4553	2	ROPS Fold Pin ASM				
②5		1	Upper Tube ASM				
5:2	107-2100	1	Decal				
5:3	107-2102	1	Decal-Warning, Folding ROPS				
6	109-2365	2	Bumper-Rubber (W/Stud)				
7	325-13	2	Screw-HH				
18	3296-29	2	Nut-Lock, NI				
②19		1	RH Tube Support ASM				
20	98-5975	8	Washer-Belleville				
21	323-6	8	Screw-HH				
22	3290-357	8	Nut-HHF, Whiz				
23	107-3059	1	Catch-Latch, Seat				
24	322-4	2	Screw-HH				
25	3296-73	2	Nut-Lock, NI				
28	110-5850	1	Seat Frame And Latch ASM				
28:2	103-4434	1	Grip-Lever				
29	110-0883	1	Retractable Seatbelt Kit				
29:2	3212-4	2	Screw-HH				
29:3	3296-7	2	Nut-Lock				
32	107-3069	1	Decal-Warning, Folding ROPS (Ce)				
47	107-2102	1	Decal-Warning, Folding ROPS				

# Attachments and Accessories

## For 74442 - Z441 Z Master, With 52in TURBO FORCE Side Discharge Mower

Product Name	Model/Part
Blade-Recycler, 18 Inch	105-7779-03
Blade-Hi Flow, 18 Inch	105-7781-03
Blade-Med Flow, 18 Inch	105-7794-03
Blade-Low Flow, 18 Inch	105-7795-03
Blade-Atomic, 18 Inch	105-7796-03
Deck Lift Assist Kit	106-9749
52 Inch Recycler Kit	107-1610
Striping Kit	107-1630
Deluxe Suspension Seat	107-1891
Suspension Kit for Standard Seat	107-1892
Z Stand Kit	107-8599
Blade-Hi-Flow, 18 Inch (6 Pack)	108-1117
Blade-Atomic, 18 Inch (6 Pack)	108-1118
Mower Deck Lift Assist Kit	108-4090
Blade-Lo-Flow, 18 Inch (6 Pack)	110-0406
Blade-Recycler, 18 Inch (6 Pack)	110-0408
Blade-Med-Flow, 18 Inch (6 Pack)	110-0409
Sunshade-Bimini	110-5726
Discharge Side Anti-Scalp Roller Kit	112-1792
Channel Reinforcement Kit	112-8673
DFS Vac Collection System	78510
Twin Bag Assembly	78532
Blower and Drive Kit	78537
Hitch Kit	99-8924

# NOTES

