



## Z500 Z Master<sup>®</sup> With 52in 7-Gauge Side Discharge Mower

Model No. 74248 - 270000001 and up.

### Parts Catalog

---

#### Ordering Replacement Parts

To order replacement parts, please supply the part number, the quantity, and the description of each part desired.

#### Understanding Reference Numbers

Each identified part in an illustration has a reference number. The reference number for a part also appears in the parts list, along with other information about the part.

This catalog uses two special reference number formats, one to indicate parts in a service assembly and another to indicate the quantity of a given part in an illustration.

#### Service Assembly Reference Numbers

Parts in service assemblies have reference numbers in the form a:b. The a represents the reference number of the entire service assembly and the b represents a sequential number unique to each part within the service assembly.

For example, a wheel assembly might be identified by reference number 6, the tire by 6:1, the valve by 6:2, and the wheel by 6:3. When you order the assembly identified by reference number 6, you receive all parts identified by reference numbers 6:1, 6:2, and 6:3. However, you may also order any part individually. Reference numbers of this type appear in illustrations and in part lists.

#### Reference Numbers Indicating Quantity

In an illustration, if a reference number indicates more than one part, the reference number has the form nX y. The n represents the quantity of the part, the X is the multiplication symbol, and the y represents the reference number.

For example, in an illustration, the reference number 2X 37 means that two of the parts identified by reference number 37 are indicated.

# Contents

Description	Page	Description	Page
Front Frame Assembly	3	Cylinder/Crankcase Assembly Kawasaki FH721D-AS08	26
Caster and Wheel Assembly	4	Piston/Crankshaft Assembly Kawasaki FH721D-AS08	28
Main Frame Assembly	5	Valve/Camshaft Assembly Kawasaki FH721D-AS08	30
Brake and Wheel Hub Assembly	6	Lubrication Equipment Assembly Kawasaki FH721D-AS08	32
Steering Control Assembly	7	Cooling Equipment Assembly Kawasaki FH721D-AS08	34
LH Motion Control Assembly No. 109-3906	8	Electric Equipment Assembly Kawasaki FH721D-AS08	36
RH Motion Control Assembly No. 109-3707	9	Control Equipment Assembly Kawasaki FH721D-AS08	38
Hydraulic System Assembly	10	Carburetor Assembly Kawasaki FH721D-AS08	40
Seat and Roll-Over Protection System Assembly	12	Air Filter/Muffler Assembly Kawasaki FH721D-AS08	42
Seat Assembly No. 110-5737	13	Fuel Tank/Valve Assembly Kawasaki FH721D-AS08	44
Roll-Over Protection System Assembly No. 108-1097	14	Starter Assembly Kawasaki FH721D-AS08	46
Deck Connection Assembly	15	Power Take Off Equipment Assembly Kawasaki FH721D-AS08	48
Deck Assembly	16	Labels Kawasaki FH721D-AS08	49
Spindle Assembly No. 107-8504	18	Attachments and Accessories List	50
Deck Decal Assembly No. 110-5551	19		
Rubber Deflector Assembly No. 108-7770	20		
Drive Idler Assembly	21		
Engine and Clutch Assembly	22		
Muffler and Guard Assembly	23		
Fuel Tank Assembly	24		
Electrical Assembly	25		

## Part Description Abbreviations

Part descriptions in this catalog may include the following abbreviations.

AR. .... as required	HYD. .... hydraulic
ASM. .... assembly	LH. .... left hand
BBC. .... blade brake clutch	NI. .... nylon insert
CARR. .... carriage	NPTF. .... national pipe thread fine
DEG. .... degrees	PFH. .... phillips flat head
EXT. .... external	PPH. .... phillips pan head
FH. .... flat head	PPHTF. .... phillips pan head thread forming
GA. .... gauge	PRH. .... phillips round head
HD. .... heavy-duty	PTH. .... phillips truss head
HF. .... hex flange	PTO. .... power-take-off
HH. .... hex head	RH. .... right hand
HHF. .... hex head flange	ROPS. .... roll-over protection system
HHFTF. .... hex head flange thread forming	SFH. .... slotted fillister head
HJ. .... hex jam	SHH. .... slotted hex head
HLH. .... hex lag head	SHWH. .... slotted hex washer head
HOC. .... height-of-cut	SPH. .... slotted pan head
HSBH. .... hex socket button head	SQH. .... square head
HSFH. .... hex socket flat head	SRH. .... slotted round head
HSH. .... hex socket head	STD. .... standard
HWH. .... hex washer head	TAP. .... self tapping
HWHTF. .... hex washer head thread forming	TTH. .... torx truss head

## Footnotes

- ❶ Not illustrated
- ❷ Obtain from your local Kawasaki dealer

- ❸ Not serviced separately

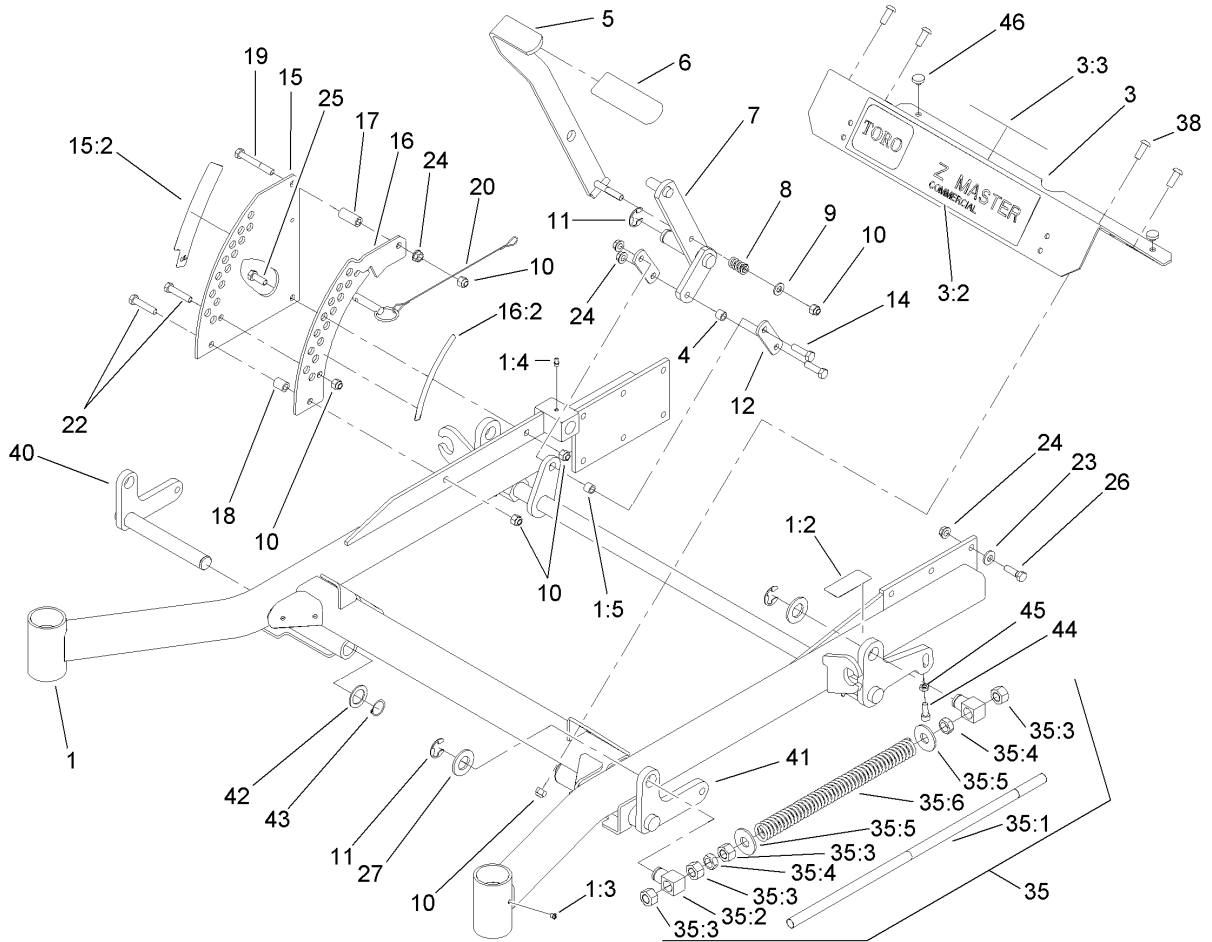

## Front Frame Assembly

Ref	Part No.	Qty.	Description
1	106-8978	1	Frame ASM
1:2	107-1857	1	Decal-Brake, Parking
1:3	1-811010	2	Plug
1:4	302-19	5	Fitting-Grease
1:5	103-1918	1	Bushing
3	106-9981	1	Footrest
3:2	106-7451	1	Decal
3:3	107-2112	1	Decal-Warning
4	103-1918	1	Bushing
5	103-2083-03	1	Lift Lever ASM
6	1-633295	1	Grip-Lever, Lift
7	103-2064-03	1	Arm-Lift, Deck
8	1-633325	1	Spring-Compression
9	3256-24	1	Washer-Flat
10	3296-39	9	Nut-Lock, NI
11	32151-103	5	Ring-Snap
12	1-633068	2	Arm-Lift, Deck
14	323-29	2	Screw-HH
15	110-0833	1	Plate-Deck Lift, Outer
15:2	107-1860	1	Decal-Height, Deck
16	110-0834	1	Plate-Deck Lift, Inner
16:2	107-1861	1	Decal-Height, Deck
17	1-633082	1	Bushing-Lever, Lift
18	1-633080	1	Bushing-Lever, Lift

Ref	Part No.	Qty.	Description
19	323-13	1	Screw-HH
20	106-9951	1	Hitch Pin ASM
22	323-9	2	Screw-HH
23	98-5975	12	Washer-Belleville
24	3290-357	15	Nut-HHF, Whiz
25	323-6	1	Screw-HH
26	323-7	12	Screw-HH
27	3256-29	4	Washer-Flat
35		2	Front Frame Spring ASM
35:1	1-633096	1	Rod-Lift, Deck
35:2	1-633441	2	Swivel-Deck Mount, Rear
35:3	3217-11	4	Nut-Hex
35:4	3218-6	2	Nut-Jam
35:5	3256-7	2	Washer-Flat
35:6	1-633064	1	Spring-Support, Deck
38	3274-94	4	Screw-HSBH
40	110-4156-01	1	RH Deck Lift ASM
41	106-8984-01	1	LH Deck Lift ASM
42	1-523157	2	Washer-Spacer
43	32151-29	2	Ring-Retaining
44	3274-18	2	Screw-HSH
45	3218-2	2	Nut-Jam
46	1-513658	2	Bumper



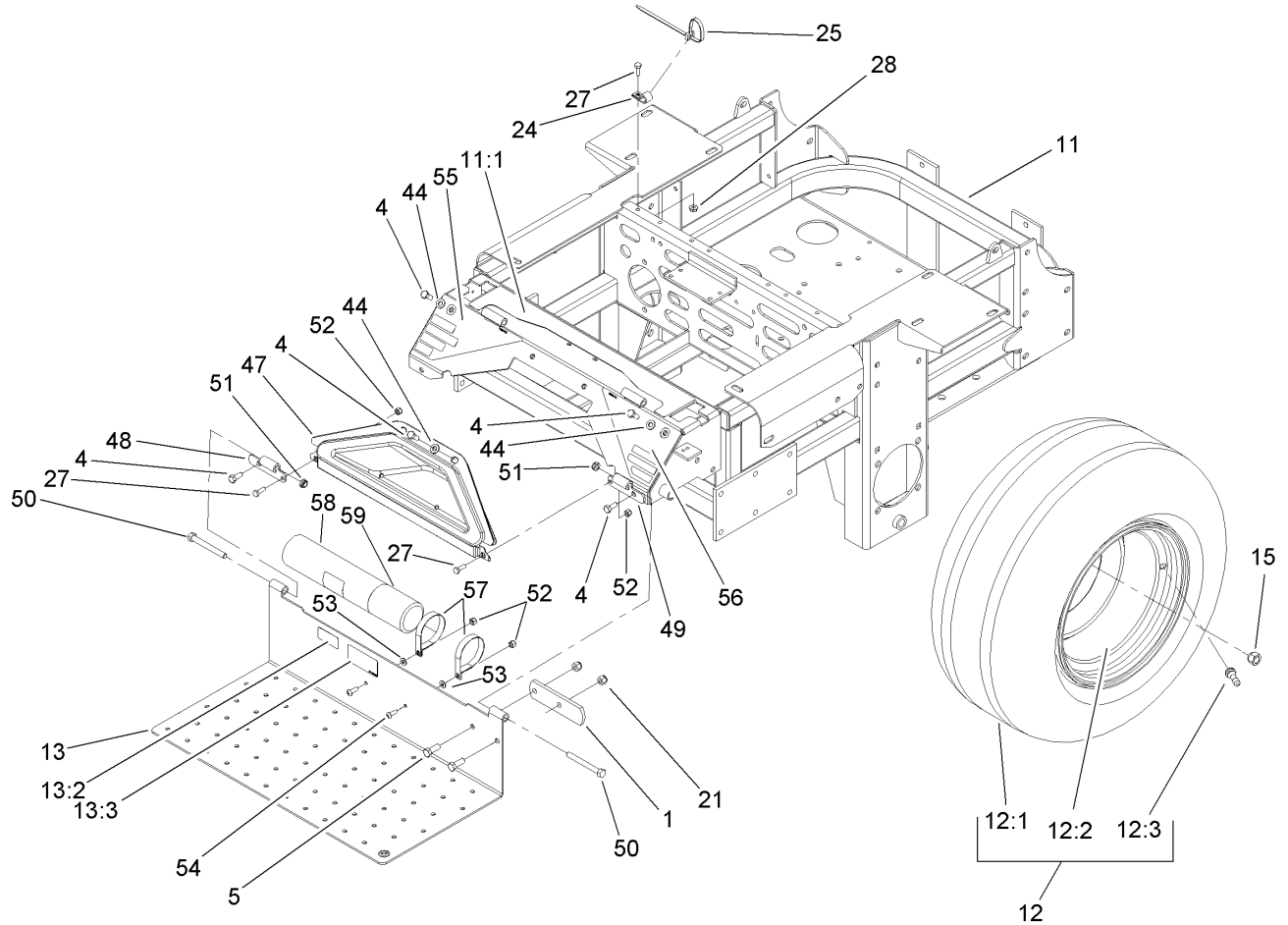

## Main Frame Assembly

Ref	Part No.	Qty.	Description
1	1-633964-03	1	Stop-Brake, Park
4	322-43	6	Screw-HH
5	323-6	2	Screw-HH
11	112-9000	1	Main Frame ASM (W/Decals)
11:1	107-8076	1	Decal-Console, Top
12	1-653010	2	Wheel And Tire ASM
12:1	1-653160	1	Tire
12:2	1-653158	1	Wheel
12:3	232-27	1	Stem-Valve
13	107-1858	1	Floorpan
13:2	98-4387	1	Decal-Protection, Ear
13:3	107-1864	1	Decal-Location, Manual
15	242-50	8	Nut-Lug
21	3296-39	2	Nut-Lock, NI
24	1-513762	1	Clip-Loom
25	1-303335	1	Tie-Plastic
27	321-4	3	Screw-HH
28	32128-33	1	Nut-HF
44	3256-70	6	Washer-Flat
47	106-7498	1	Pocket
48	106-7488-03	1	Hinge-Floorpan, LH
49	106-7489-03	1	Hinge-Floorpan, RH
50	323-20	2	Screw-HH
51	3296-59	2	Nut-Lock, NI

Ref	Part No.	Qty.	Description
52	3296-42	4	Nut-Lock, NI
53	3256-63	2	Washer-Flat
54	3258-166	2	Screw-PRH
55	106-9989	1	Decal-Warning
56	106-7492	1	Decal-Danger
57	107-1865	2	R-Clamp
58	104-7050	1	Housing-Manual
59	104-7048	1	Cap-Housing

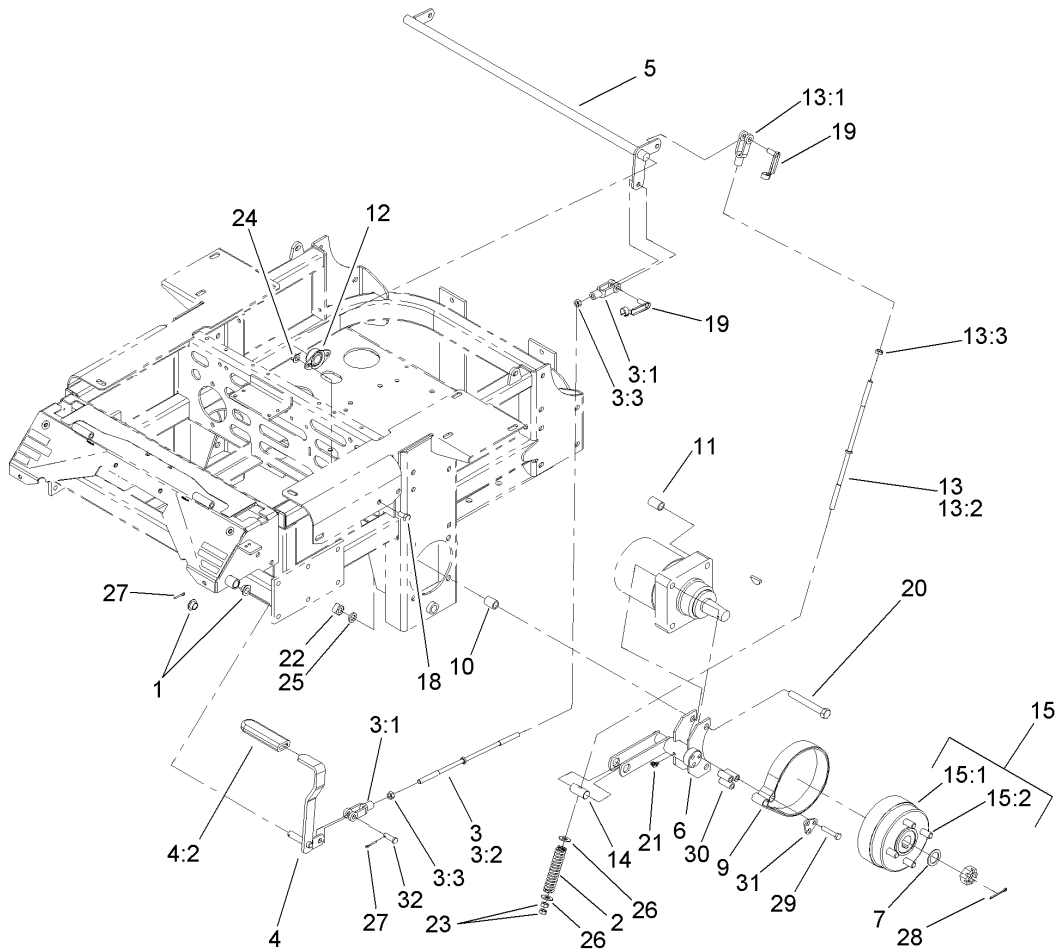

## Brake and Wheel Hub Assembly

Ref	Part No.	Qty.	Description
1	1-513140	2	Bearing-Control
2	1-633454	2	Spring-Brake
3	103-4332	1	Brake Rod And Yoke ASM
3:1	1-633131	2	Yoke-Linkage, Brake
3:2	1-633477	1	Rod-Brake
3:3	3219-3	2	Nut-Hex
4	1-634500	1	Brake Lever ASM
4:2	1-633268	1	Grip-Lever, Brake
5	1-632217-03	1	Shaft-Brake
6	103-0352-03	2	Bracket-Brake
7	1-523157	2	Washer-Spacer
9	103-0355	2	Band-Brake
10	1-633380	4	Spacer-Wheel, Short
11	1-633382	4	Spacer-Wheel, Long
12	1-633102	2	Bearing-Flange, Side
13	103-4333	2	Brake Rod And Yoke ASM
13:1	1-633131	1	Yoke-Linkage, Brake
13:2	1-633477	1	Rod-Brake
13:3	3219-3	1	Nut-Hex
14	1-633144	2	Pin-Trunion
15	103-0590	2	Hub And Wheel ASM
15:1	103-0589	1	Wheel Hub ASM
15:2	1-633926	4	Stud-Wheel
18	323-4	4	Screw-HH

Ref	Part No.	Qty.	Description
19	103-2399	3	Pin-Spring, Clevis
20	325-17	8	Screw-HH
21	1481	2	Fitting-Grease
22	103-0131	8	Nut-Square
23	3219-3	4	Nut-Hex
24	3290-357	4	Nut-HHF, Whiz
25	3253-7	8	Washer-Lock
26	3256-4	4	Washer-Flat
27	3272-10	2	Pin-Cotter
28	1-806800	2	Pin-Cotter
29	322-9	6	Screw-HH
30	103-0384	6	Spacer
31	103-0374	2	Retainer-Band, Brake
32	1-808285	1	Pin-Clevis

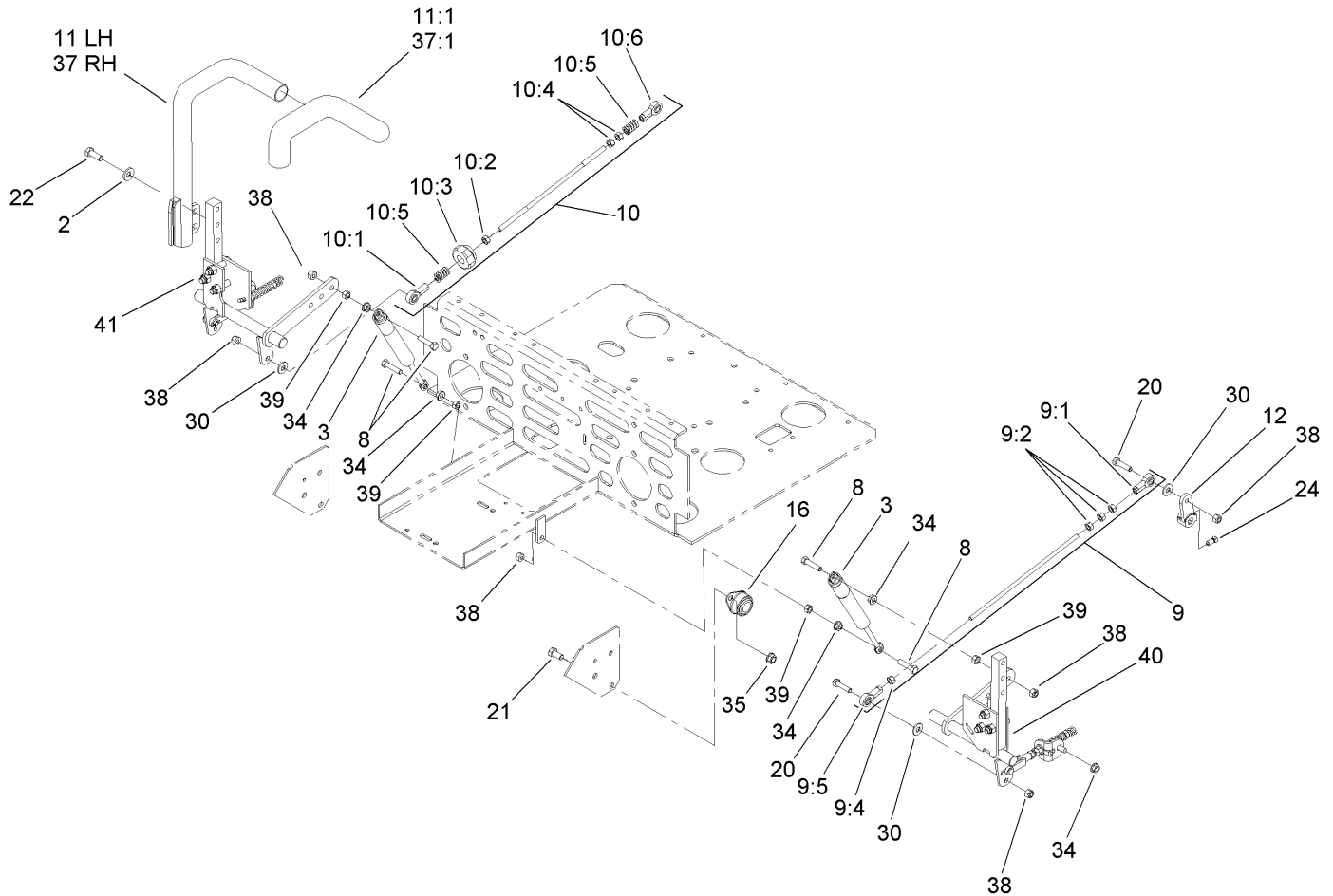

## Steering Control Assembly

Ref	Part No.	Qty.	Description
2	98-5975	4	Washer-Belleville
3	109-2339	2	Damper-Control, Motion
8	1-403180	4	Screw-HH
9	103-4331	1	Tracking Rod ASM
9:1	1-543017	1	Balljoint-RH
9:2	3219-2	3	Nut-Hex
9:4	1-804524	1	Nut
9:5	1-633152	1	Balljoint-LH
10	103-4330	1	Tracking Rod ASM
10:1	1-543017	1	Balljoint-RH
10:2	3219-2	1	Nut-Hex
10:3	103-3060	1	Knob-Tracking
10:4	1-804524	2	Nut
10:5	1-323245	2	Spring-Compression
10:6	1-633152	1	Balljoint-LH
11	103-0631	1	LH Lever ASM
11:1	1-633257	1	Grip-Control, Motion
12	1-632208	2	Arm-Control, Pump
16	1-633102	4	Bearing-Flange, Side
20	322-6	4	Screw-HH
21	323-4	8	Screw-HH
22	323-6	4	Screw-HH
24	1-803022	2	Screw-Set
30	3256-3	4	Washer-Flat

Ref	Part No.	Qty.	Description
34	32128-20	6	Nut-HF
35	3290-357	8	Nut-HHF, Whiz
37	103-0632	1	RH Lever ASM
37:1	1-633257	1	Grip-Control, Motion
38	3296-29	8	Nut-Lock, NI
39	3217-6	4	Nut-Hex
40	109-3906	1	LH Motion Control ASM
41	109-3907	1	RH Motion Control ASM



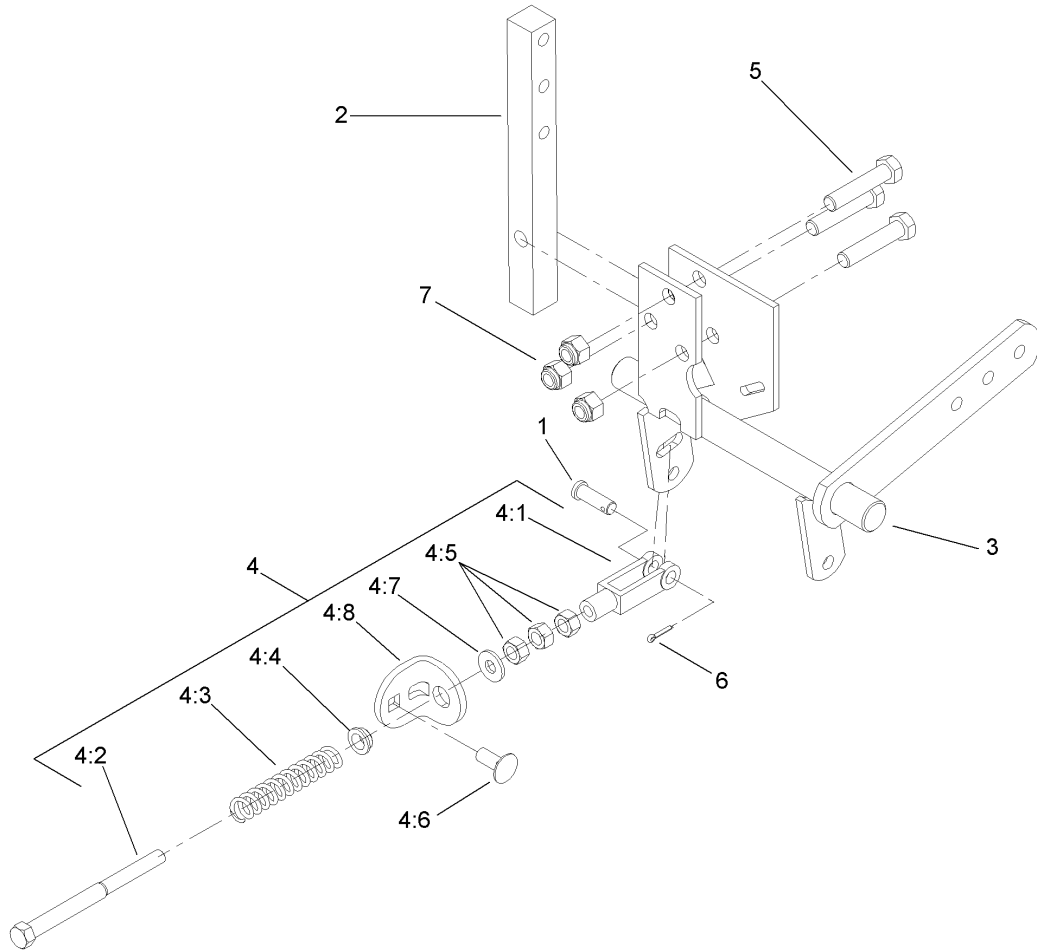

## RH Motion Control Assembly No. 109-3707

Ref	Part No.	Qty.	Description
1	1-808280	1	Pin-Clevis
2	103-0407	1	Arm-Shaft, Control
3	109-3901	1	Control-Motion, RH
4	109-3903	1	Neutral Return ASM
4:1	1-303105	1	Yoke-Adjustable
4:2	1-603737	1	Bolt-Return, Neutral
4:3	1-603807	1	Spring-Return, Neutral
4:4	109-3769	1	Bushing-Nylon, Flanged
4:5	3219-2	3	Nut-Hex
4:6	3230-23	1	Screw-CARR
4:7	3256-2	1	Washer-Flat
4:8	109-3908	1	Tab-Adjustment
5	323-9	3	Screw-HH
6	3272-5	1	Pin-Cotter
7	3296-39	3	Nut-Lock, NI

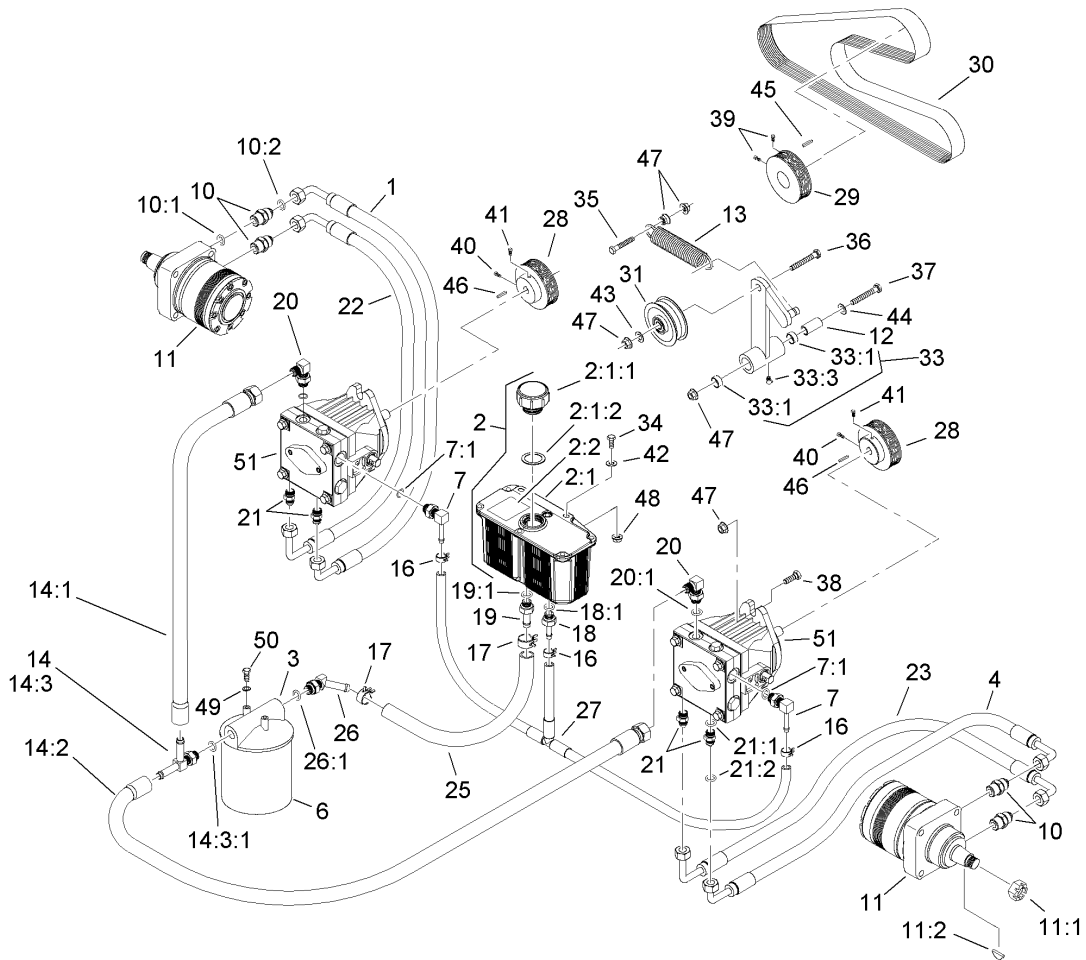



## Hydraulic System Assembly

Ref	Part No.	Qty.	Description
1	103-3736	1	HYD Hose ASM
2	103-1947	1	HYD Reservoir ASM
2:1		1	Reservoir-HYD
2:1:1	103-1948	1	Cap-Reservoir, HYD
2:1:2	103-1949	1	Gasket-Cap
2:2	1-523552	1	Decal-Tank, HYD
3	104-7836	1	Head-Filter
4	103-3733	1	HYD Hose ASM
6	1-633750	1	Filter-Oil, HYD
6	1-633752	1	Filter-HYD, Winter
7	103-1799	2	Elbow-90 DEG
7:1	237-42	1	O-Ring
10	1-603991	4	Fitting-Straight
10:1	237-80	1	O-Ring
10:2	1-603992	1	O-Ring
11	103-6988	2	Motor-Wheel
11:1	1-809036	1	Nut-HH
11:2	3257-42	1	Key-Woodruff
11:99	103-2748	1	Drive Link Kit
11:99	103-6994	1	Seal Kit
12	1-603384	1	Bushing-Pivot, Idler
13	103-3330	1	Spring-Extension
14	109-1936	1	Pump Inlet Hose ASM
14:1	103-1826	1	HYD Hose ASM

Ref	Part No.	Qty.	Description
14:2	103-1827	1	HYD Hose ASM
14:3	103-1828	1	Adapter-Run, Tee
14:3:1	237-42	1	O-Ring
16	103-1716	3	Clamp-Hose
17	103-1988	2	Clamp-Hose
18	103-1801	1	Adapter-Straight
18:1	237-42	1	O-Ring
19	103-1912	1	Adapter-Straight
19:1	237-42	1	O-Ring
20	103-1802	2	Fitting-HYD, 90 DEG
20:1	1-603921	1	O-Ring
21	1-603990	4	Fitting-Straight
21:1	1-603920	1	O-Ring
21:2	1-603992	1	O-Ring
22	103-3737	1	HYD Hose ASM
23	103-3735	1	HYD Hose ASM
25	103-1808	1	Hose-HYD
26	103-1807	1	Elbow-45 DEG
26:1	237-42	1	O-Ring
27	103-1806	1	HYD Hose ASM
28	103-6907	2	Sheave
29	1-633567	1	Sheave
30	103-7445	1	Belt-V
31	1-633167	1	Sheave-Idler

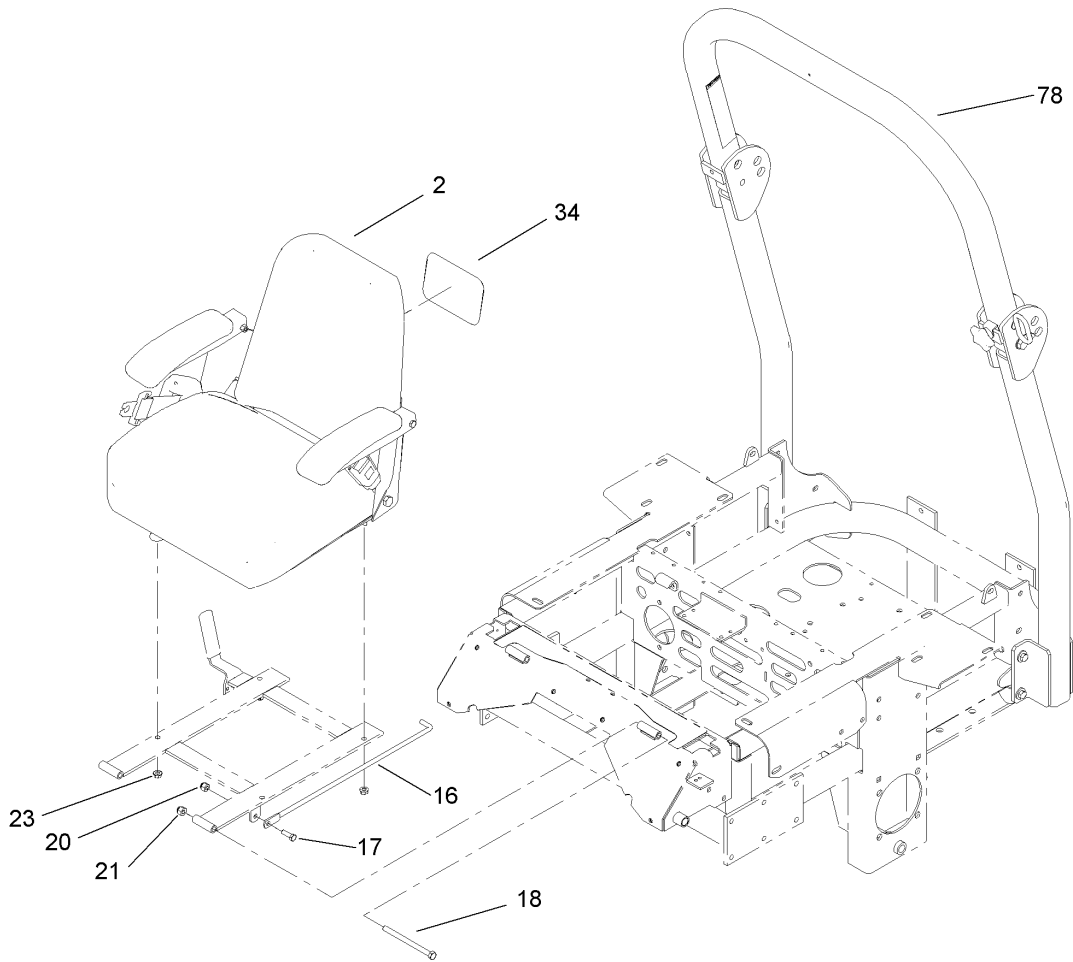



## Seat and Roll-Over Protection System Assembly

Ref	Part No.	Qty.	Description				
2	110-5737	1	Seat ASM				
16	1-633293	1	Rod-Holdup, Seat				
17	322-5	1	Screw-HH				
18	323-39	2	Screw-HH				
20	3296-29	3	Nut-Lock, NI				
21	3296-39	3	Nut-Lock, NI				
23	32128-20	4	Nut-HF				
34	99-4693	1	Decal				
78	108-1097	1	ROPS ASM				



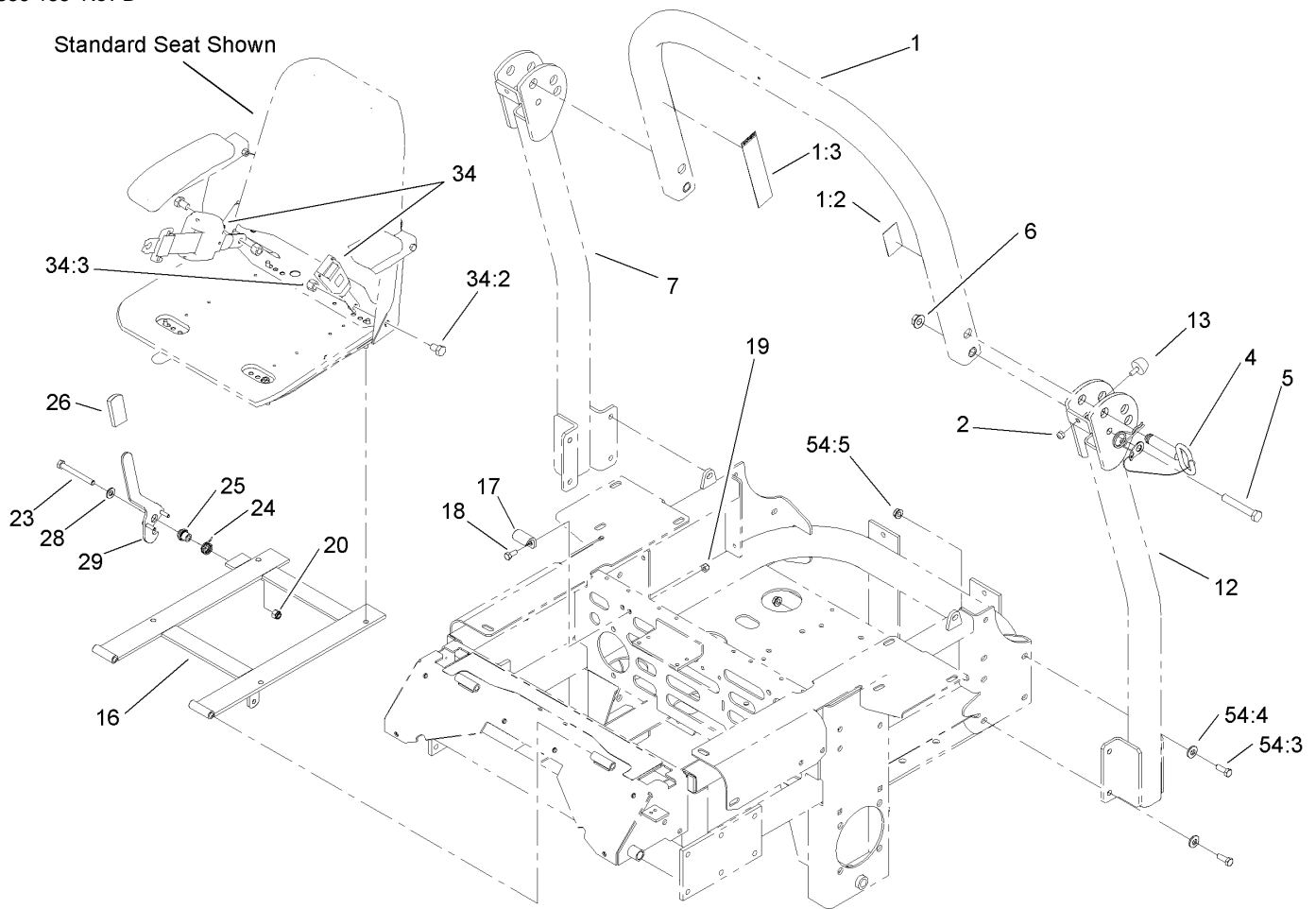

## Roll-Over Protection System Assembly No. 108-1097

Ref	Part No.	Qty.	Description
① 1		1	Upper Tube ASM
1:2	107-2101	1	Decal-ROPS
1:3	107-2102	1	Decal-Warning, Folding ROPS
2	3296-73	2	Nut-Lock, NI
4	103-4553	2	ROPS Fold Pin ASM
5	325-13	2	Screw-HH
6	32128-23	2	Nut-HF
② 7		1	Tube-Support, RH
② 12		1	Tube-Support, LH
13	109-2365	2	Bumper-Rubber (W/Stud)
16	107-3052-03	1	Seat Support Frame ASM
17	107-3058	1	Catch-Latch, Seat
18	322-3	2	Screw-HH
19	3296-29	2	Nut-Lock, NI
20	3296-39	1	Nut-Lock, NI
23	323-20	1	Screw-HH
24	107-0076	1	Spring-Torsion
25	107-0075	1	Bushing-Latch, Seat
26	103-4434	1	Grip-Lever
28	3256-24	1	Washer-Flat
29	107-3083	1	Latch ASM
34	110-0883	1	Retractable Seatbelt Kit
34:2	3212-4	2	Screw-HH
34:3	3296-7	2	Nut-Lock

Ref	Part No.	Qty.	Description
① ② 54		1	Bag-Bolt, ROPS
54:3	323-6	8	Screw-HH
54:4	98-5975	8	Washer-Belleville
54:5	3290-357	8	Nut-HHF, Whiz



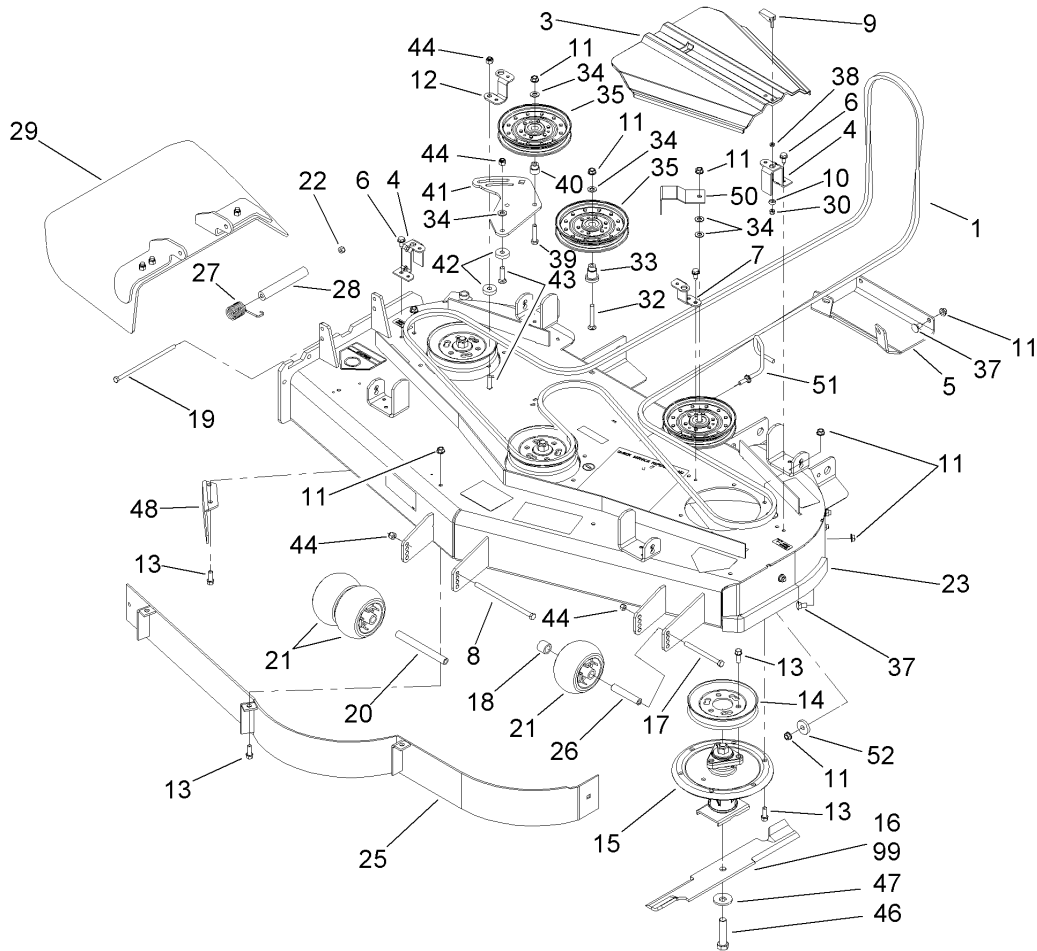

## Deck Assembly

Ref	Part No.	Qty.	Description
1	105-7790	1	Belt
3	107-8536	2	Cover-Belt
4	108-4121-01	2	Bracket-Cover
5	106-7358-01	1	Plate-Skid
6	32144-70	3	Screw-HWHTF
7	108-2177-01	1	Bracket-Cover, Tall
8	323-28	1	Screw-HH
9	106-6777	2	Handle-Latch, Swell
10	106-6778	2	Bushing-Latch, Swell
11	3290-357	39	Nut-HHF, Whiz
12	108-2178-01	1	Bracket-Cover, Short
13	92-1624	32	Screw
14	105-7735	3	Pulley
15	107-8504	3	Spindle ASM
16	105-7781-03	3	Blade-Hi Flow
17	323-23	1	Screw-HH
18	98-7913	1	Tube-Spacer
19	322-50	1	Screw-HH
20	98-5967	1	Spacer-Wheel
21	1-603299	3	Roller-Scalp, Anti
22	3296-29	1	Nut-Lock, NI
23	110-5551	1	Deck ASM
25	108-2185-01	1	Baffle ASM
26	98-7912	1	Tube-Spanner

Ref	Part No.	Qty.	Description
27	108-4052	1	Spring-Torsion
28	105-4622	1	Spacer
29	108-7770	1	Rubber Deflector ASM
30	1-804254	2	Nut
32	3231-31	2	Screw-CARR
33	106-3214	2	Mount-Pulley
34	3256-24	5	Washer-Flat
35	1-633109	3	Idler-Flat
37	3231-1	12	Screw-CARR
38	99-3058	2	Washer
39	323-9	1	Screw-HH
40	1-603496	1	Bushing-Idler
41	107-8516-01	1	Plate-Idler
42	105-7788	2	Spacer
43	3231-4	2	Screw-CARR
44	3296-39	4	Nut-Lock, NI
46	103-0862	3	Screw-Cap
47	103-0865	3	Washer-Blade Bolt, Heavy
48	106-3216-01	1	Baffle-Discharge
50	108-7220-01	1	Guide-Belt
51	106-3220	1	Guide-Belt
52	112843	1	Washer
●99	105-7794-03	1	Blade-Med Flow
●99	105-7795-03	1	Blade-Low Flow

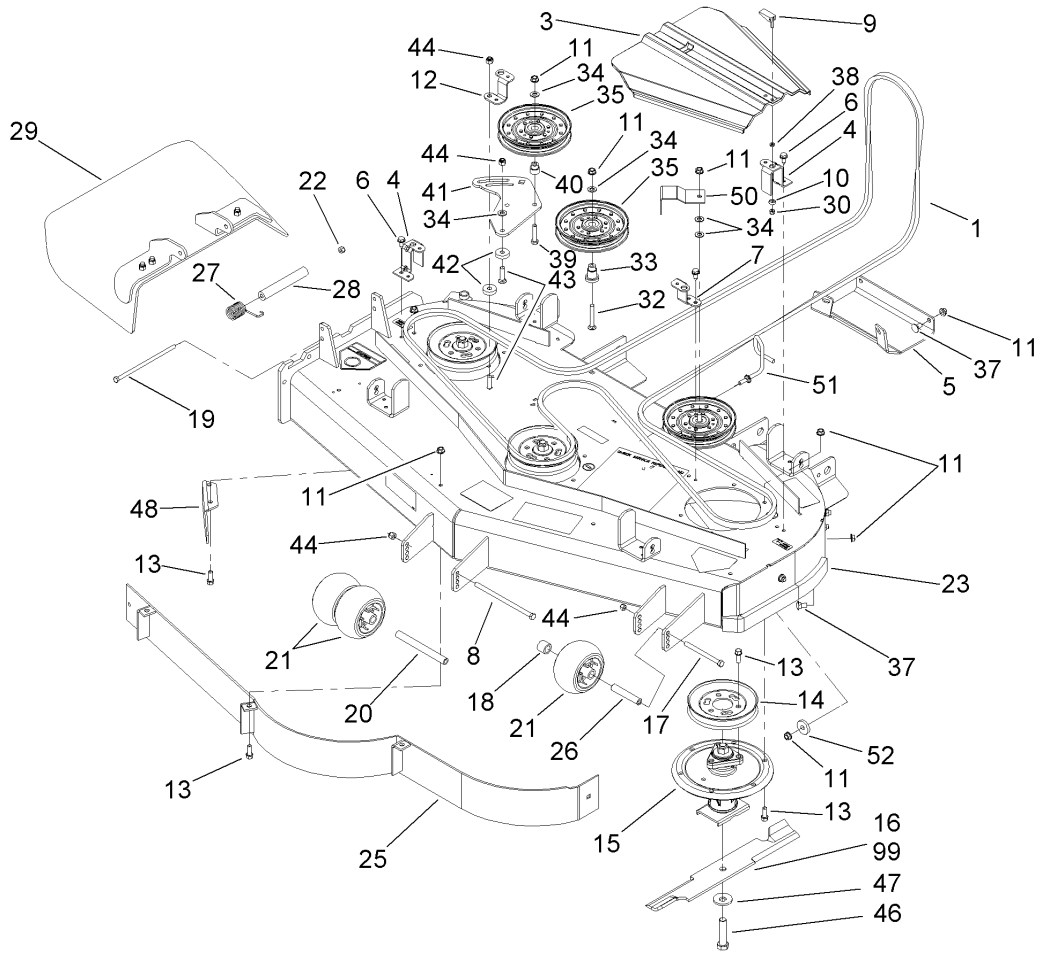

### Deck Assembly (continued)

Ref	Part No.	Qty.	Description
●99	105-7796-03	1	Blade-Atomic
●99	105-7779-03	1	Blade-Recycler

--	--	--	--





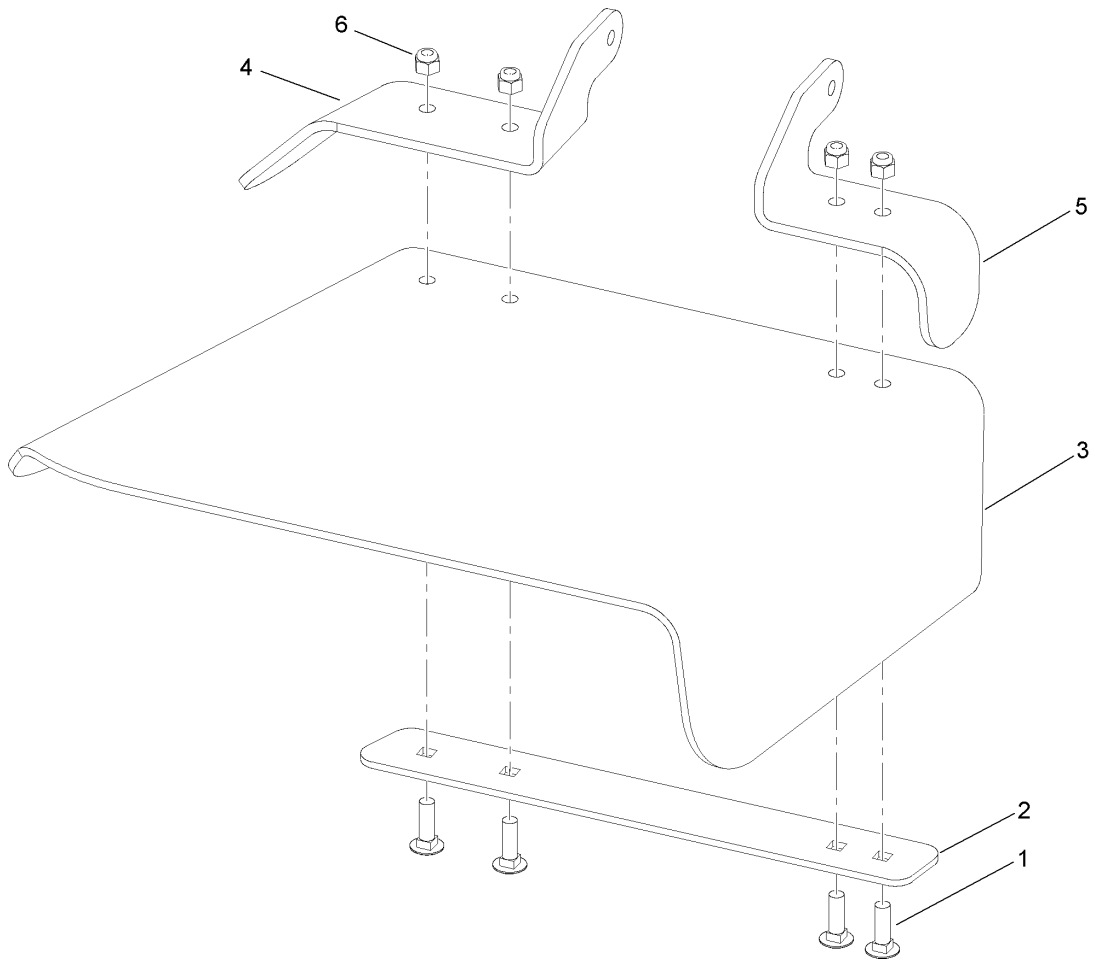

### Rubber Deflector Assembly No. 108-7770

Ref	Part No.	Qty.	Description
1	3231-25	4	Screw-CARR
2	106-3248-03	1	Strap-Discharge
3	108-5029	1	Deflector-Rubber
4	108-7767-03	1	Bracket-Hinge, Rear
5	108-7766-03	1	Bracket-Hinge, Front
6	3296-39	4	Nut-Lock, NI

Ref	Part No.	Qty.	Description

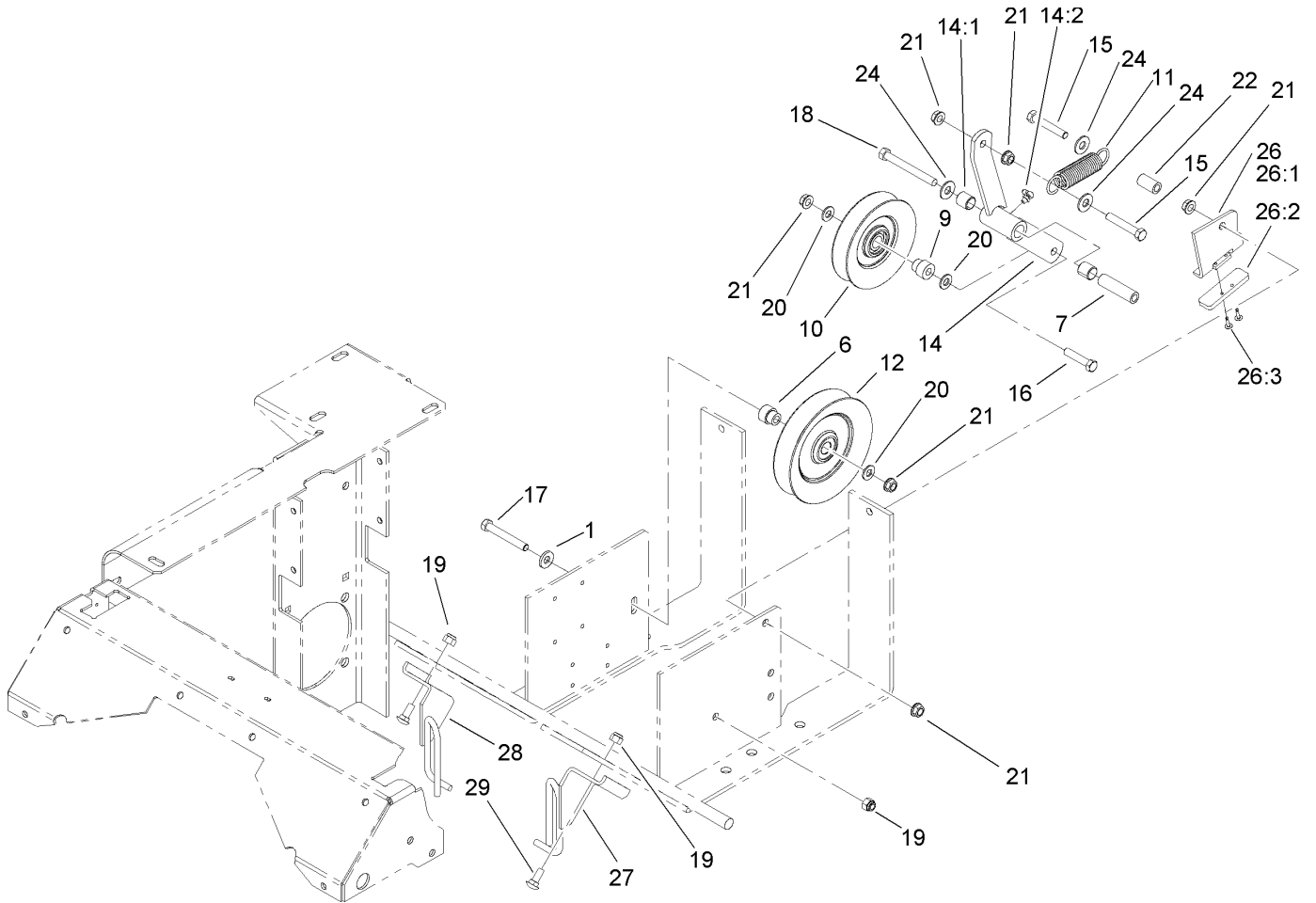

## Drive Idler Assembly

Ref	Part No.	Qty.	Description
1	98-5975	1	Washer-Belleville
6	103-2627	1	Bushing-Idler
7	1-603384	1	Bushing-Pivot, Idler
9	1-603496	1	Bushing-Idler
10	99-4638	1	Idler
11	1-603402	1	Spring-Extension
12	1-633166	1	Pulley-Idler
14	103-3147	1	Arm ASM
14:1	1-513034	2	Sleeve-Bearing
14:2	302-40	1	Fitting-Grease
15	323-12	2	Screw-HH
16	323-9	1	Screw-HH
17	323-13	1	Screw-HH
18	1-800805	1	Screw-HH
19	3296-39	3	Nut-Lock, NI
20	3256-24	3	Washer-Flat
21	3290-357	6	Nut-HHF, Whiz
22	1-603401	1	Spacer-Fender
24	3256-4	3	Washer-Flat
26	106-3271	1	Travel Limiter ASM
26:1	106-3228-03	1	Plate-Limiter, Pulley
26:2	106-3229	1	Pad-Bumper
26:3	3269-24	2	Rivet
27	108-7204-03	1	Guide-Belt, LH

Ref	Part No.	Qty.	Description
28	108-7229-03	1	Guide-Belt, RH
29	3231-2	2	Screw-CARR

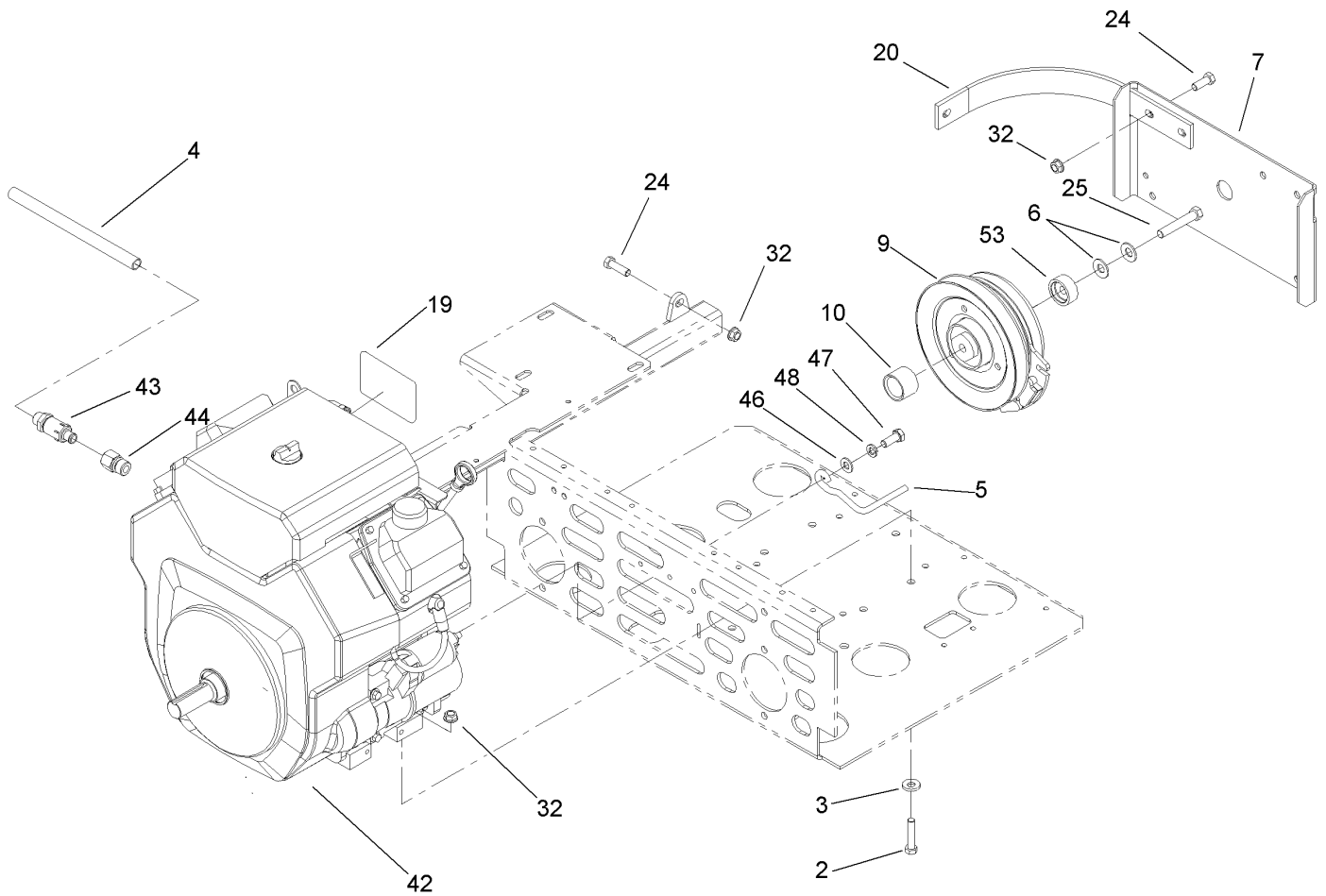

## Engine and Clutch Assembly

Ref	Part No.	Qty.	Description
2	323-9	4	Screw-HH
3	98-5975	4	Washer-Belleville
4	106-7022	1	Tube-Drain, Oil
5	52-4780	1	Rod-Belt
6	1-603610	2	Washer-Spring
7	1-633615-03	1	Guard-Clutch
9	110-0449	1	Clutch-Electromagnetic
10	1-633179	1	Spacer-Clutch
19	103-3270	1	Decal
20	103-7454-03	2	Strap-Guard
24	323-6	6	Screw-HH
25	3212-6	1	Screw-HH
32	3290-357	8	Nut-HHF, Whiz
42		1	Engine-Kawasaki, FH721D-As08
43	92-6877	1	Valve-Drain, Oil
44	103-1966	1	Adapter
46	3256-24	1	Washer-Flat
47	33115-025	1	Screw-HH
48	98-5975	1	Washer-Belleville
53	103-0152	1	Keeper-Clutch

Ref	Part No.	Qty.	Description

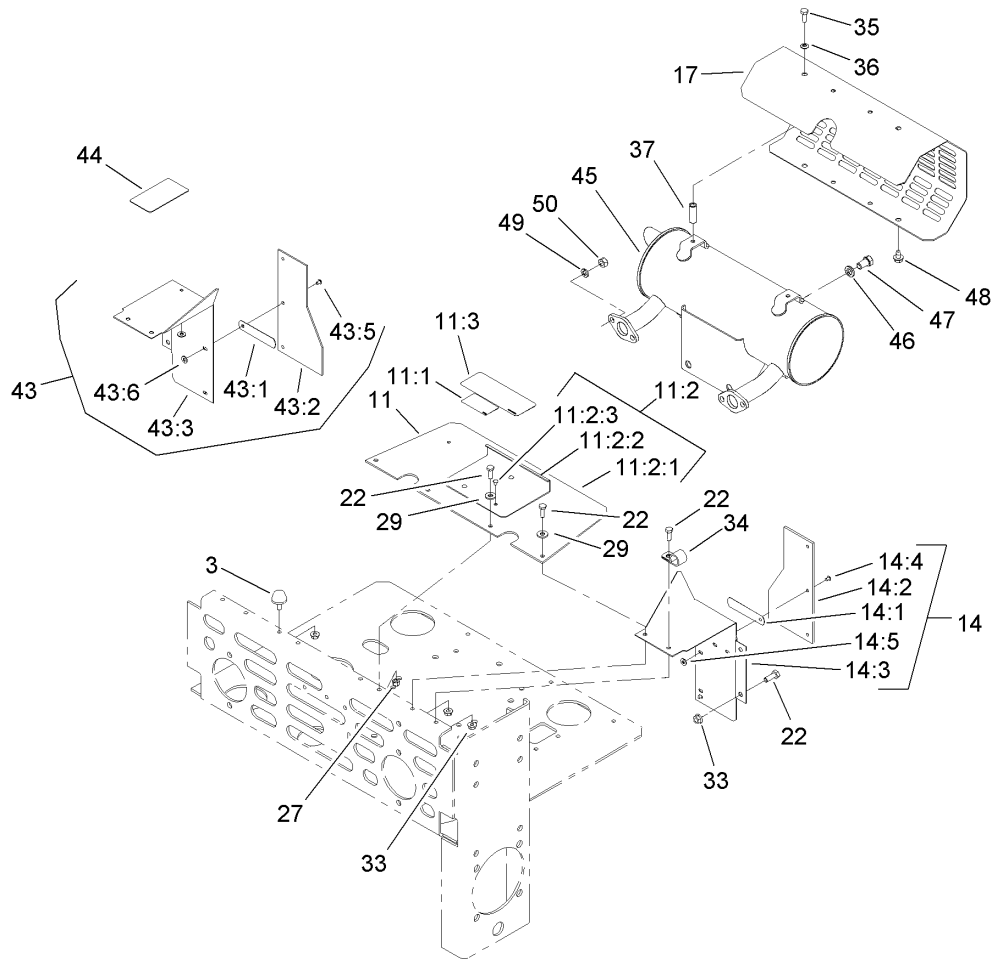

## Muffler and Guard Assembly

Ref	Part No.	Qty.	Description
3	109-2365	2	Bumper-Rubber (W/Stud)
11	105-6196	1	Shield ASM
11:1	1-633462	1	Decal-Important
11:2	103-1301	1	Drive Cover ASM
11:2:1	103-1308	1	Shield-Engine
11:2:2	103-1304-03	1	Plate-Cover, Drive
11:2:3	1-803035	5	Rivet-Pop
11:3	103-5881	1	Decal-Devices, Rotating
14	103-0241	1	LH Extended Shield ASM
14:1	1-523285	2	Clip-Baffle, Rear
14:2	103-0243	1	Shield
14:3	1-633795-03	1	Baffle-Engine Shield, LH
14:4	1-803035	3	Rivet-Pop
14:5	3256-63	3	Washer-Flat
17	1-643313-03	1	Guard-Muffler
22	321-4	10	Screw-HH
27	3296-42	4	Nut-Lock, NI
29	3256-2	4	Washer-Flat
33	32128-33	5	Nut-HF
34	1-633396	1	Clip-Loom
35	1-809108	2	Screw-HWH
36	1-323235	2	Washer-Spring
37	1-323236	2	Spacer
43	103-0242	1	RH Extended Shield ASM

Ref	Part No.	Qty.	Description
43:1	1-523285	2	Clip-Baffle, Rear
43:2	103-0243	1	Shield
43:3	1-633794-03	1	Shield-RH
43:5	1-803035	3	Rivet-Pop
43:6	3256-63	3	Washer-Flat
44	1-643339	1	Decal-Routing, Belt
45	103-2758	1	Muffler
46	3253-6	2	Washer-Lock
47	324-2	2	Screw-HH
48	9266934	2	Screw
49	1-805005	4	Washer-Lock
50	33014-00	4	Nut-Hex

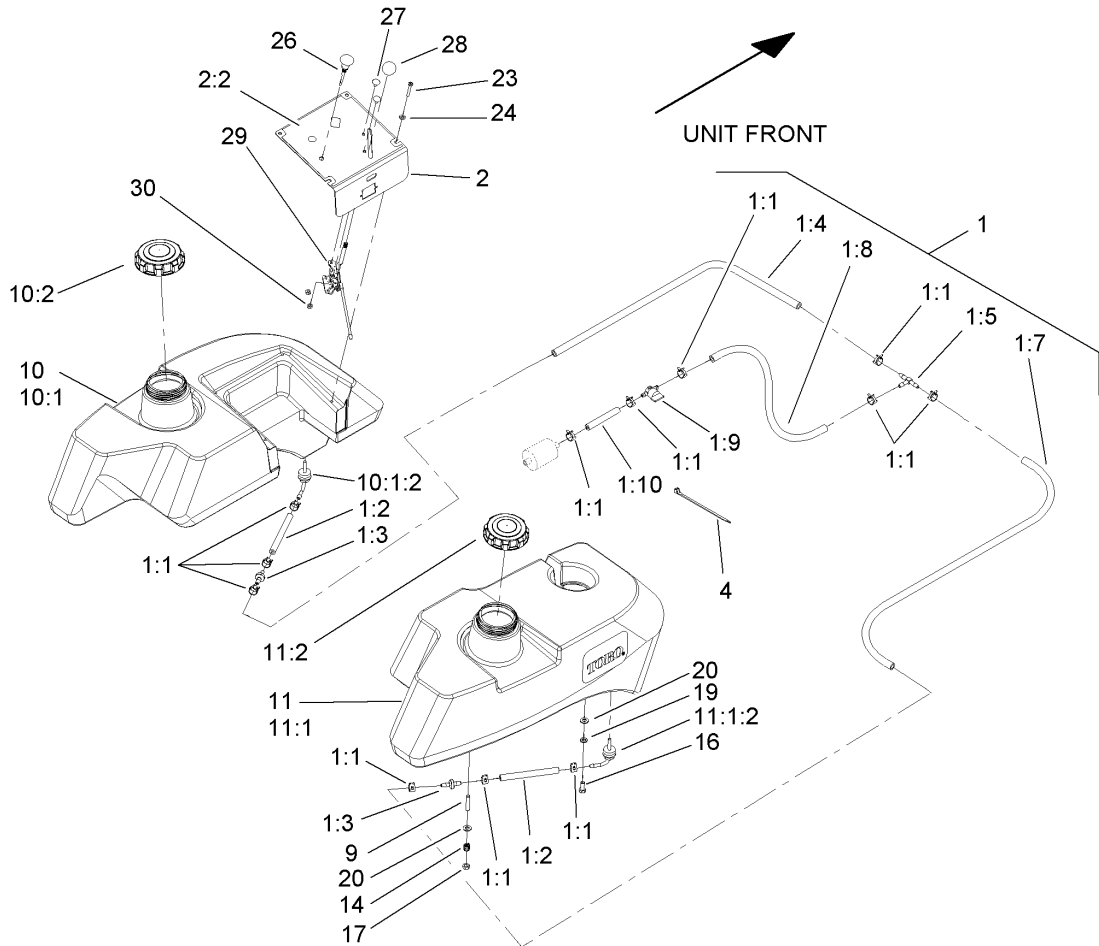

## Fuel Tank Assembly

Ref	Part No.	Qty.	Description
1	107-9285	1	Fuel Line ASM
1:1	1-303077	12	Clamp
1:2	109-0678	2	Hose-Fuel
1:3	99-5000	2	Valve-Check, Fuel
1:4	109-0305	1	Hose-Fuel
1:5	99-5005	1	Fitting-Tee, Barbed
1:7	109-0302	1	Hose-Fuel
1:8	110-5702	1	Hose-Fuel
1:9	1-603770	1	Valve-Fuel
1:10	109-0660	1	Hose-Fuel
2	110-5732	1	Control Panel ASM
2:2	110-5731	1	Decal-Panel, Control
4	1-303335	4	Tie-Plastic
9	1-633023	6	Stud
10	105-3644	1	LH Fuel Tank Kit ASM
⑩10:1		1	LH Fuel Tank ASM
10:1:2	103-2605	1	Fitting-Fuel, Bulkhead
10:2	109-0346	1	Cap-Fuel, Gas
11	105-3643	1	RH Fuel Tank Kit ASM
⑩11:1		1	RH Fuel Tank ASM
11:1:2	103-2605	1	Fitting-Fuel, Bulkhead
11:2	109-0346	1	Cap-Fuel, Gas
14	1-633349	6	Spring-Tank, Fuel
16	322-3	2	Screw-HH

Ref	Part No.	Qty.	Description
17	3296-47	6	Nut-Lock, NI
19	1-805005	2	Washer-Lock
20	3256-23	8	Washer-Flat
23	3251-1	4	Screw-PPH
24	1-303435	4	Washer-Spring
26	106-9962	1	Control-Choke, Push / Pull
27	1-807513	2	Bolt-CARR
28	1-513592	1	Knob-Ball
29	107-8073	1	Cable-Throttle
30	3296-2	2	Nut-Lock

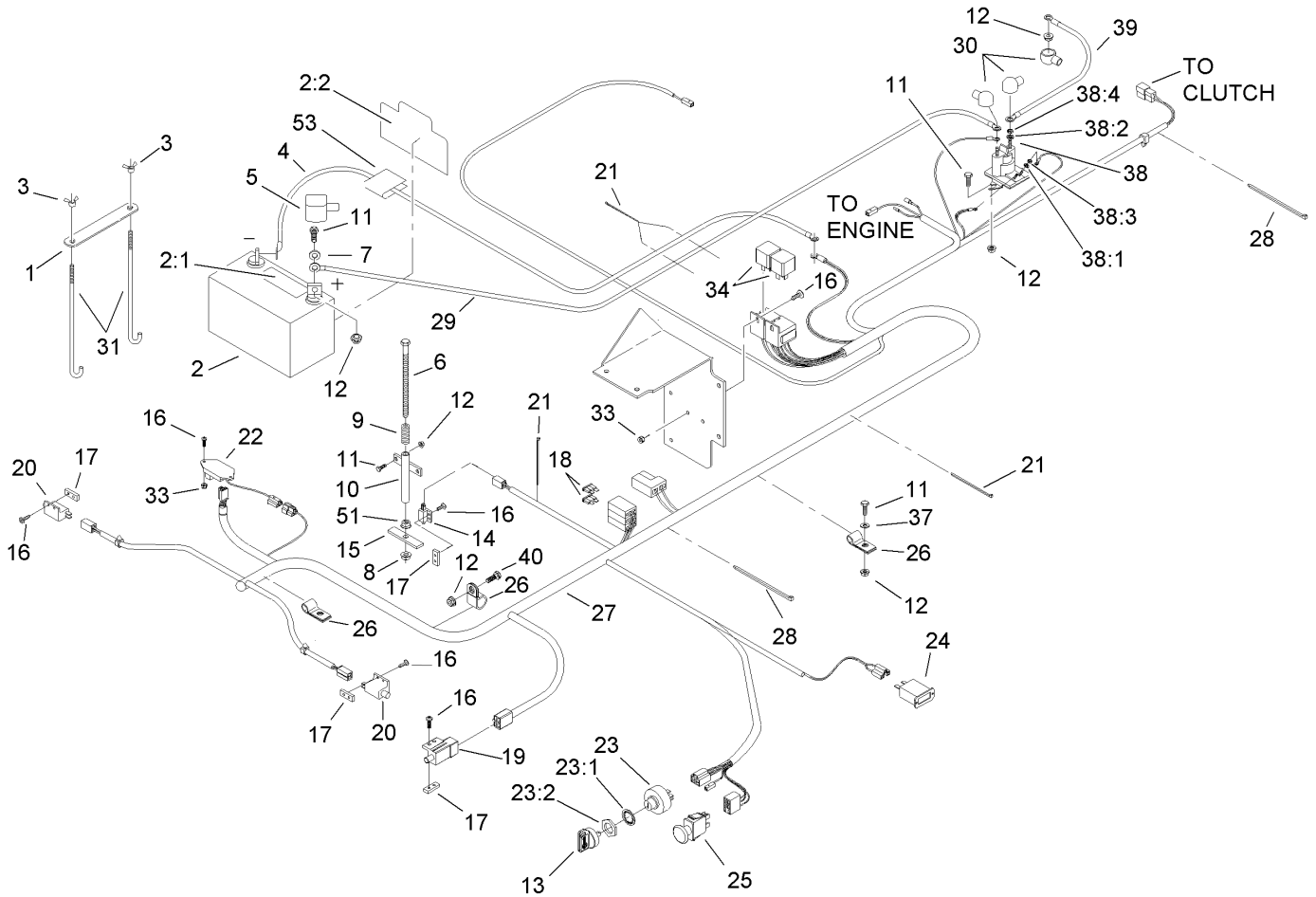

## Electrical Assembly

Ref	Part No.	Qty.	Description
1	107-9277-03	1	Strap-Holddown, Battery
2	105-1692	1	Battery
2:1	104-4163	1	Decal-Battery
2:2	104-4164	1	Decal-Battery
3	1-543792	2	Wingnut
4	1-633307	1	Wire-Ground
5	1-543391	1	Insulator-Battery
6	1-800282	1	Screw-HH
7	3256-2	2	Washer-Flat
8	3296-29	1	Nut-Lock, NI
9	1-523415	1	Spring-Switch, Seat
10	1-522424-03	1	Mount-Spring, Seat
11	321-4	8	Screw-HH
12	32128-33	8	Nut-HF
13	63-8360	2	Key-Ignition
14	1-513152	1	Switch-Closed, Normally
15	1-513180	1	Plate-Switch, Seat
16	3290-500	12	Screw-PPH
17	1-633181	4	Plate-Tapped
18	1-816001	2	Fuse-Blade Type, 20 Amp
19	1-633111	1	Switch
20	1-513051	2	Switch-Open, Normally
21	1-303287	5	Tie-Plastic
22	100-6186	1	Module-Delay, Seat

Ref	Part No.	Qty.	Description
23	103-0206	1	Switch-Starting, Key
23:1	3254-5	1	Washer-Tooth
23:2	218-461	1	Nut-HH
24	1-513374	1	Meter-Hour
25	103-5221	1	Switch-PTO
26	1-633396	3	Clip-Loom
27	106-7494	1	Harness-Wire
28	1-303335	2	Tie-Plastic
29	1-523281	1	Wire-Starter
30	1-543393	3	Insulator-Solenoid
31	1-633651	2	Bolt-Holddown
33	3296-2	4	Nut-Lock
34	1-643275	2	Relay
37	3256-22	1	Washer-Flat
38	1-513075	1	Switch-Solenoid
38:1	3253-17	2	Washer-Lock
38:2	3253-4	2	Washer-Lock
38:3	3219-14	2	Nut-Hex
38:4	3220-2	2	Nut-Jam
39	1-633306	1	Cable-Starter, Positive
40	321-2	1	Screw-HH
51	3217-6	1	Nut-Hex
53	107-9309	1	Decal-Instructions, Charging



## Cylinder/Crankcase Assembly Kawasaki FH721D-AS08

Ref	Part No.	Qty.	Description				
⑤11004	11004-7006	2	Gasket-Head				
⑤11008	11008-7012	1	Head-Cylinder, No. 2				
⑤11008A	11008-7013	1	Head-Cylinder, No. 1				
⑤11022	11022-7002	1	Case-Rocker				
⑤11022A	11022-7004	1	Case-Rocker				
⑤11060	11060-7013	2	Gasket-Case, Rocker				
⑤11060A	11060-7014	1	Gasket-Breather				
⑤11060B	11060-7023	1	Gasket-Crankcase				
⑤12021	12021-7002	1	Valve Reed ASM				
⑤14091	14091-7004	1	Cover				
⑤32153	32153-7003	1	Pipe				
⑤32153A	32153-7004	1	Pipe				
⑤49015	49015-6256	1	Cover-Crankcase				
⑤49120	49120-6137	1	Crankcase				
⑤92033	92033-7004	1	Ring-Snap				
⑤92043	92043-7001	6	Pin				
⑤92049	92049-7001	4	Seal-Oil (R Vc2 6X11X10.2)				
⑤92049A	92049-7005	1	Seal-Oil (So 8X14X5 Hs)				
⑤92049B	92049-7007	1	Seal-Oil				
⑤92049C	92049-7010	1	Seal-Oil (Sd 35X48X8 R Hs)				
⑤130	130B0612	4	Bolt-Flanged (6X12)				
⑤130A	130B0640	4	Bolt-Flanged (6X40)				
⑤130B	130T0850	18	Bolt-Flanged (8X50)				
⑤130C	130T0875	2	Bolt-Flanged (8X75)				
⑤172	172G0818	4	Bolt-Stud (8X18)				
⑤214	214B0408	2	Screw-Pan (4X8)				

# Piston/Crankshaft Assembly Kawasaki FH721D-AS08

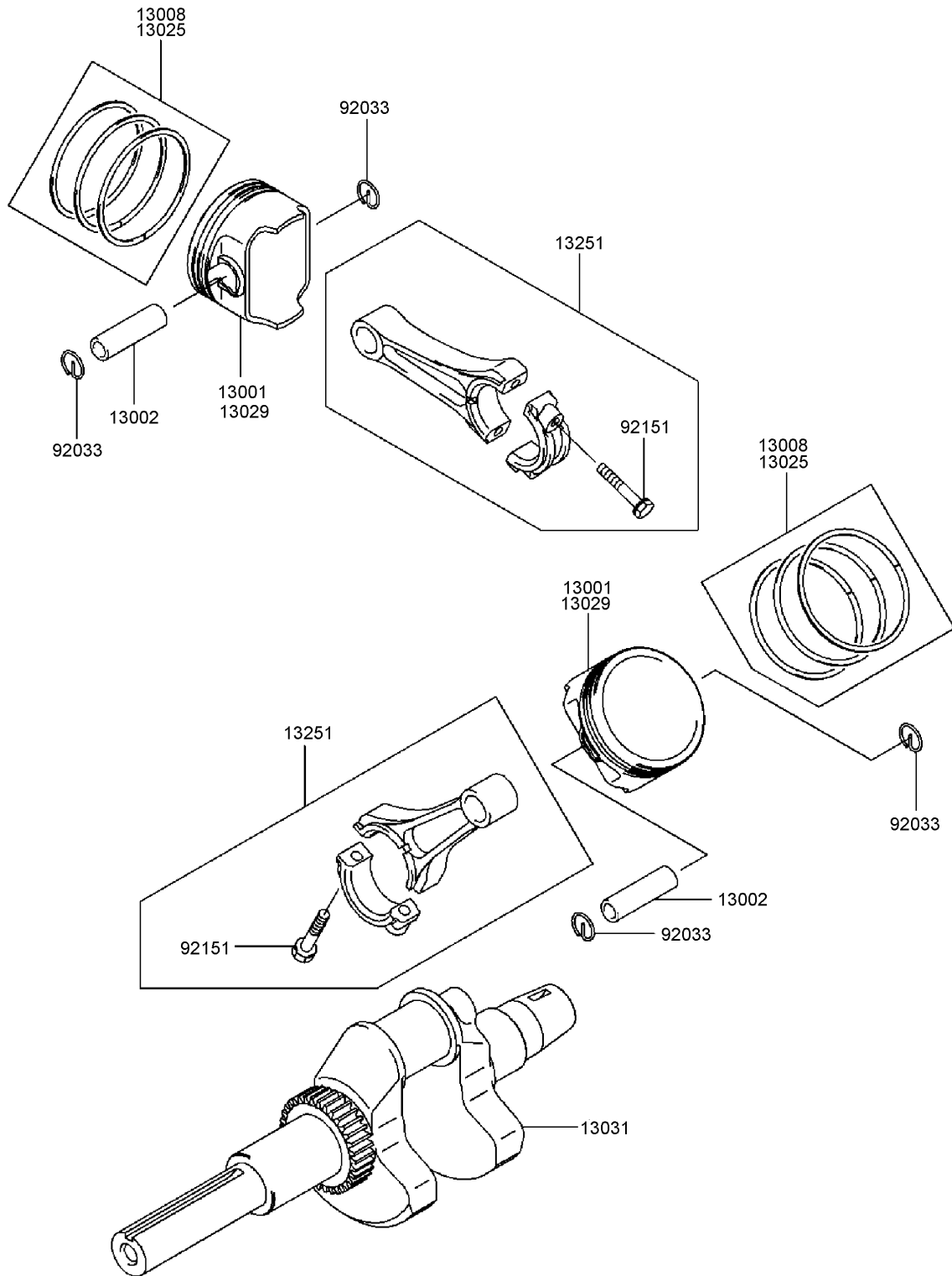

## Piston/Crankshaft Assembly Kawasaki FH721D-AS08

Ref	Part No.	Qty.	Description				
⑤13001	13001-7007	2	Piston-Engine				
⑤13002	13002-7001	2	Pin-Piston				
⑤13008	13008-6058	2	Ring Set-Piston				
⑤13025	13025-7002	1	Ring Set-Piston (L,0.50)				
⑤13029	13029-7003	1	Piston-Engine (L,0.50)				
⑤13031	13031-7007	1	Crankshaft				
⑤13251	13251-7005	2	Connecting Rod ASM				
⑤92033	92033-7005	4	Ring-Snap				
⑤92151	92151-7017	4	Bolt (6X35)				

# Valve/Camshaft Assembly Kawasaki FH721D-AS08

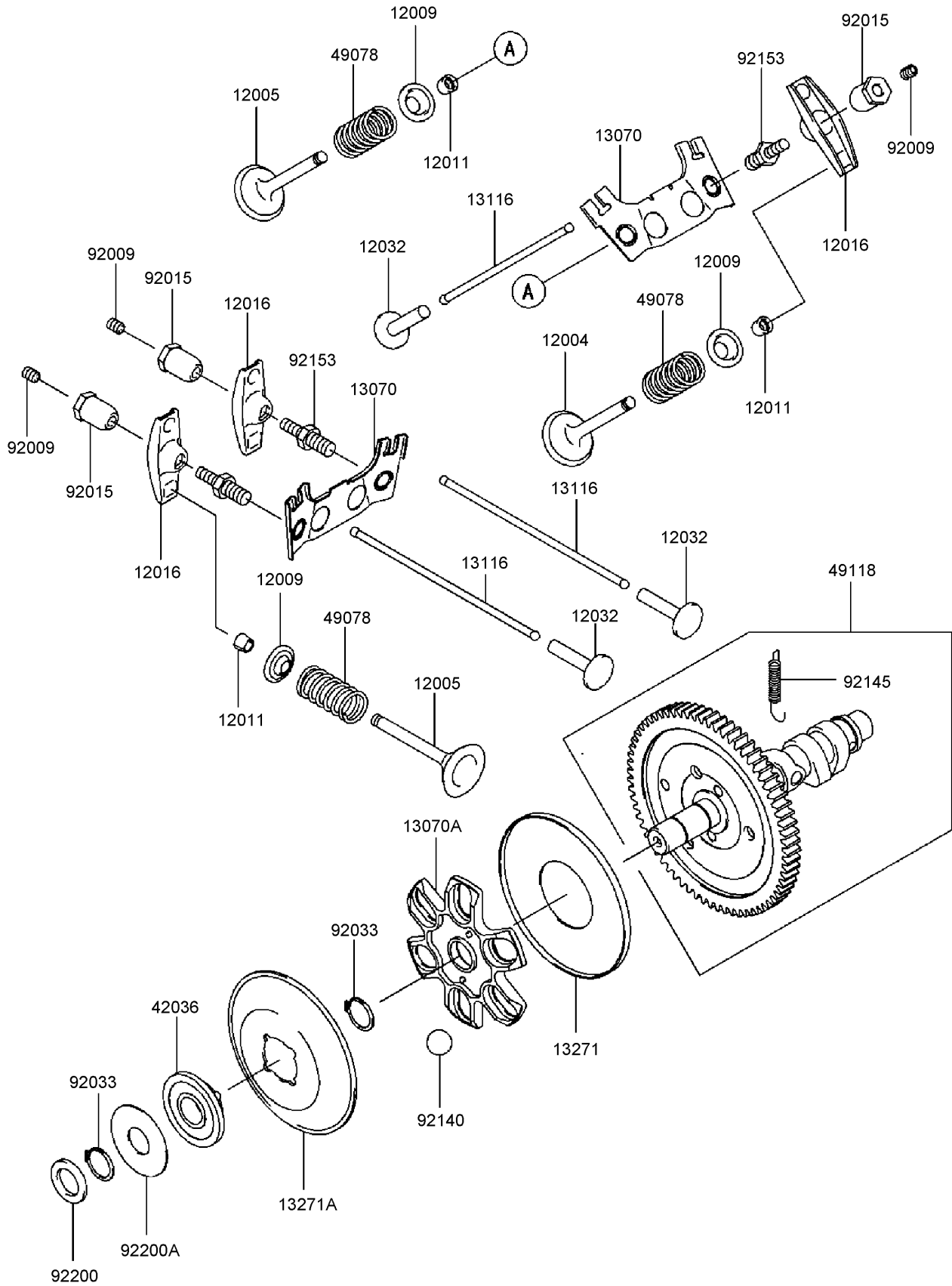

## Valve/Camshaft Assembly Kawasaki FH721D-AS08

Ref	Part No.	Qty.	Description				
⑤12004	12004-7002	2	Valve-Intake				
⑤12005	12005-7004	2	Valve-Exhaust				
⑤12009	12009-7001	4	Retainer-Spring, Valve				
⑤12011	12011-2056	8	Collet				
⑤12016	12016-7006	4	Arm-Rocker				
⑤12032	12032-7001	4	Tappet				
⑤13070	13070-7007	2	Guide				
⑤13070A	13070-7008	1	Guide				
⑤13116	13116-7002	4	Rod-Push				
⑤13271	13271-7007	1	Plate				
⑤13271A	13271-7021	1	Plate-Governor				
⑤42036	42036-7009	1	Sleeve				
⑤49078	49078-7002	4	Spring-Valve, Engine				
⑤49118	49118-7007	1	Camshaft				
⑤92009	92009-2341	4	Screw				
⑤92015	92015-2253	4	Nut				
⑤92033	92033-7001	2	Ring-Snap				
⑤92140	92140-7002	6	Ball				
⑤92145	92145-7001	1	Spring				
⑤92153	92153-7019	4	Bolt				
⑤92200	92200-7001	1	Washer				
⑤92200A	92200-7009	1	Washer (16X42X0.91)				

# Lubrication Equipment Assembly Kawasaki FH721D-AS08

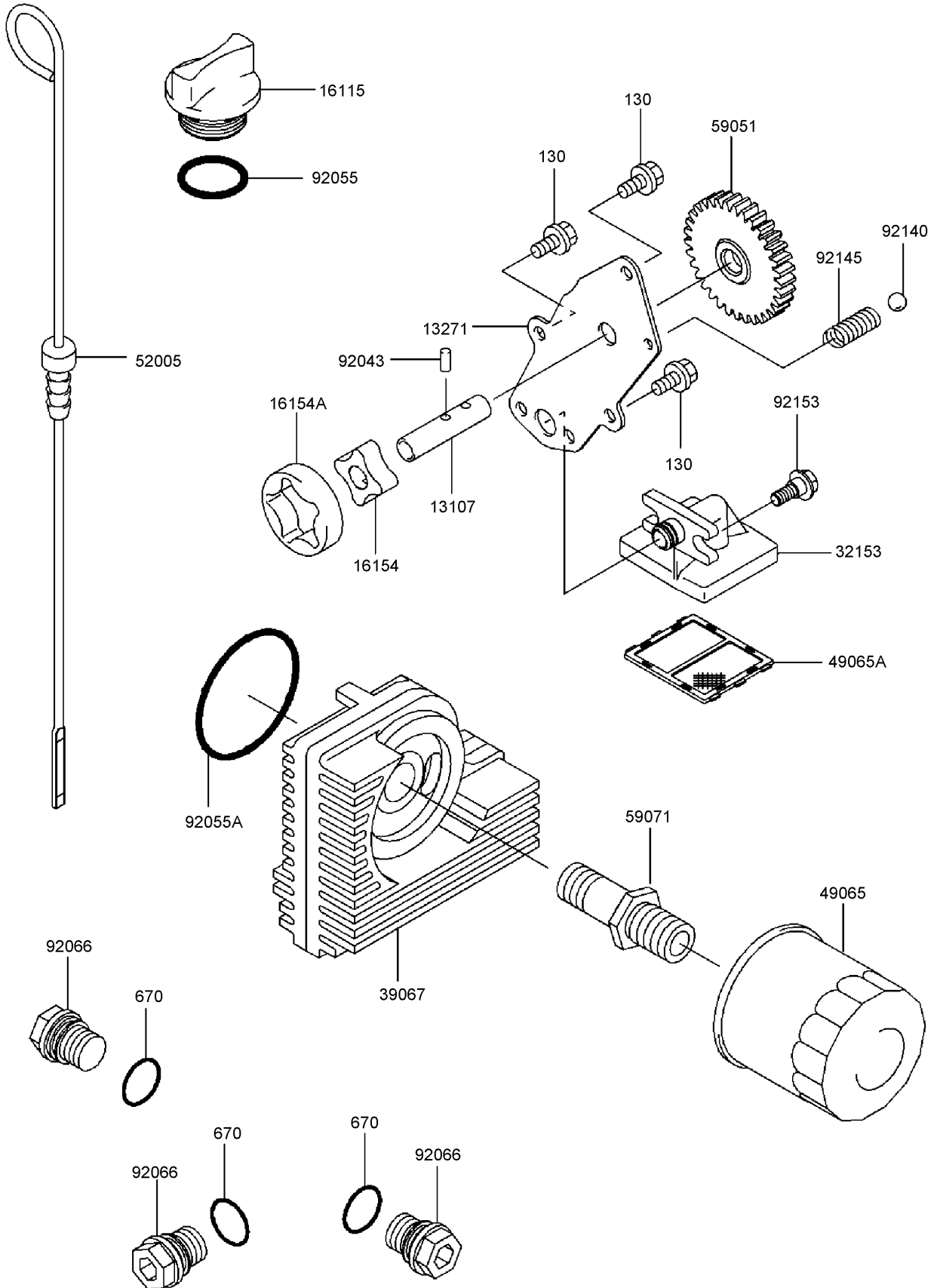

## Lubrication Equipment Assembly Kawasaki FH721D-AS08

Ref	Part No.	Qty.	Description				
③13107	13107-7009	1	Shaft				
③13271	13271-7014	1	Plate				
③16115	16115-7001	1	Cap-Filler, Oil				
③16154	16154-2053	1	Rotor-Pump ,In				
③16154A	16154-2054	1	Rotor-Pump, Out				
③32153	32153-7002	1	Pipe				
③39067	39067-7002	1	Cooler-Oil				
③49065	49065-2078	1	Filter-Oil				
③49065A	49065-7005	1	Filter-Oil				
③52005	52005-7003	1	Gauge				
③59051	59051-7011	1	Gear-Spur				
③59071	59071-7009	1	Joint				
③92043	92043-7003	2	Pin				
③92055	92055-7004	1	O-Ring				
③92055A	92055-7006	1	O-Ring (Id=58)				
③92066	92066-7003	3	Plug				
③92140	92140-7003	1	Ball				
③92145	92145-7002	1	Spring				
③92153	92153-7007	2	Bolt				
③130	130B0612	3	Bolt-Flanged (6X12)				
③670	670D2016	3	O-Ring (16Mm)				

# Cooling Equipment Assembly Kawasaki FH721D-AS08

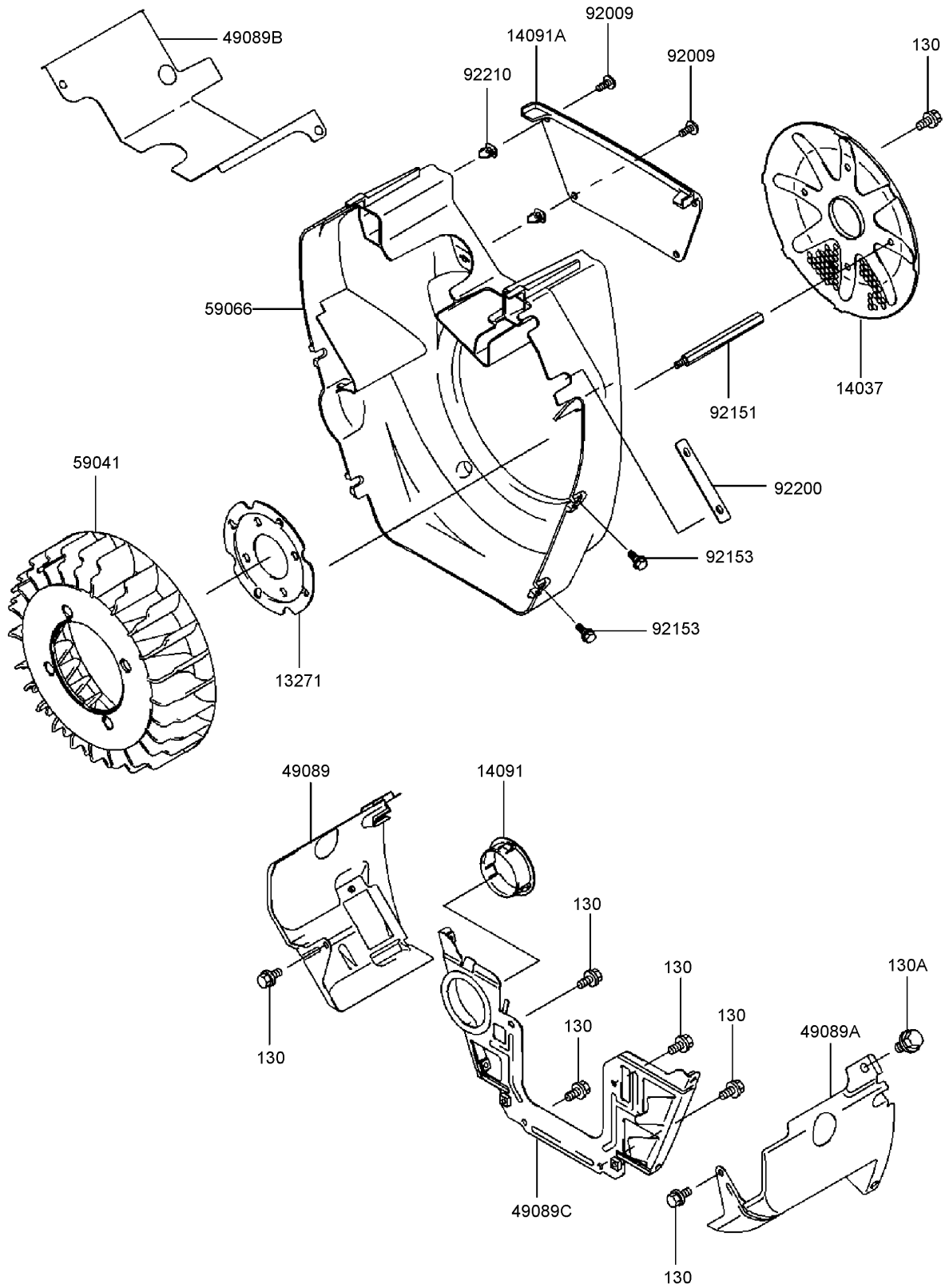

## Cooling Equipment Assembly Kawasaki FH721D-AS08

Ref	Part No.	Qty.	Description				
③13271	13271-7015	1	Plate				
③14037	14037-7014	1	Screen				
③14091	14091-7002	1	Cover				
③14091A	14091-7005	1	Cover				
③49089	49089-7004	1	Shroud-Engine				
③49089A	49089-7005	1	Shroud-Engine				
③49089B	49089-7019	1	Shroud-Engine				
③49089C	49089-7027	1	Shroud-Engine				
③59041	59041-7004	1	Fan				
③59066	59066-7005	1	Housing-Fan				
③92009	92009-7009	4	Screw				
③92151	92151-7018	4	Bolt				
③92153	92153-7007	4	Bolt				
③92200	92200-7011	1	Washer				
③92210	92210-7011	4	Nut				
③130	130B0612	10	Bolt-Flanged (6X12)				
③130A	130B0816	2	Bolt-Flanged (8X16)				

# Electric Equipment Assembly Kawasaki FH721D-AS08

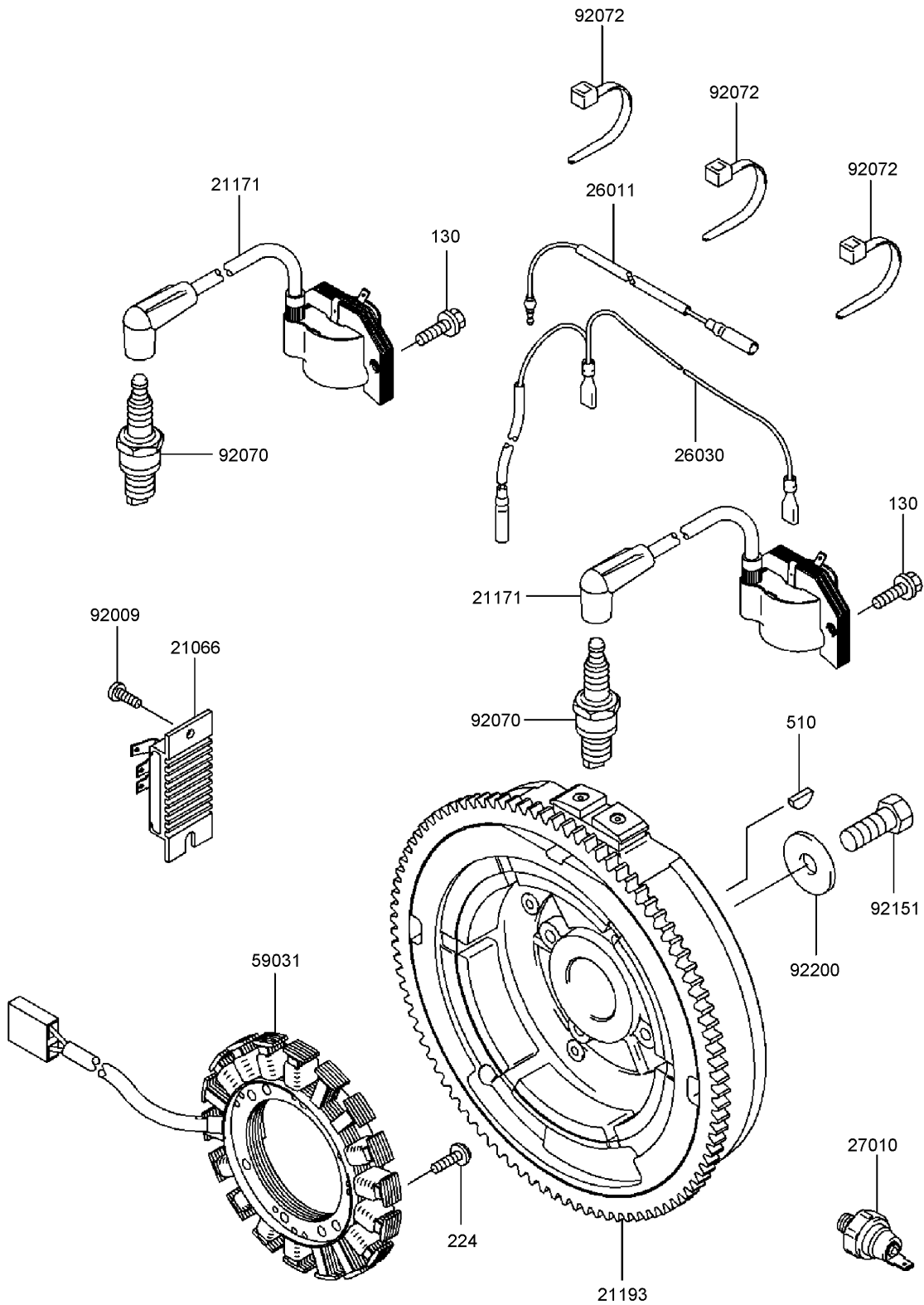

## Electric Equipment Assembly Kawasaki FH721D-AS08

Ref	Part No.	Qty.	Description				
②1066	21066-7011	1	Regulator-Voltage				
②1171	21171-7013	2	Ignition Coil ASM				
②1193	21193-7021	1	Flywheel ASM				
②6011	26011-7008	1	Wire-Lead (L=540)				
②6030	26030-7002	1	Harness				
②7010	27010-7001	1	Switch				
②59031	59031-7001	1	Coil-Charging				
②92009	92009-2308	1	Screw				
②92070	92070-7004	2	Plug-Spark (Bpr4Es (Ngk) Solid)				
②92072	92072-7003	3	Band				
②92151	92151-2097	1	Bolt (12X30)				
②92200	92200-7002	1	Washer				
②130	130B0620	4	Bolt-Flanged (6X20)				
②224	224B0520	4	Screw-Pan (5X20)				
②510	510A5100	1	Key-Woodruff				

# Control Equipment Assembly Kawasaki FH721D-AS08

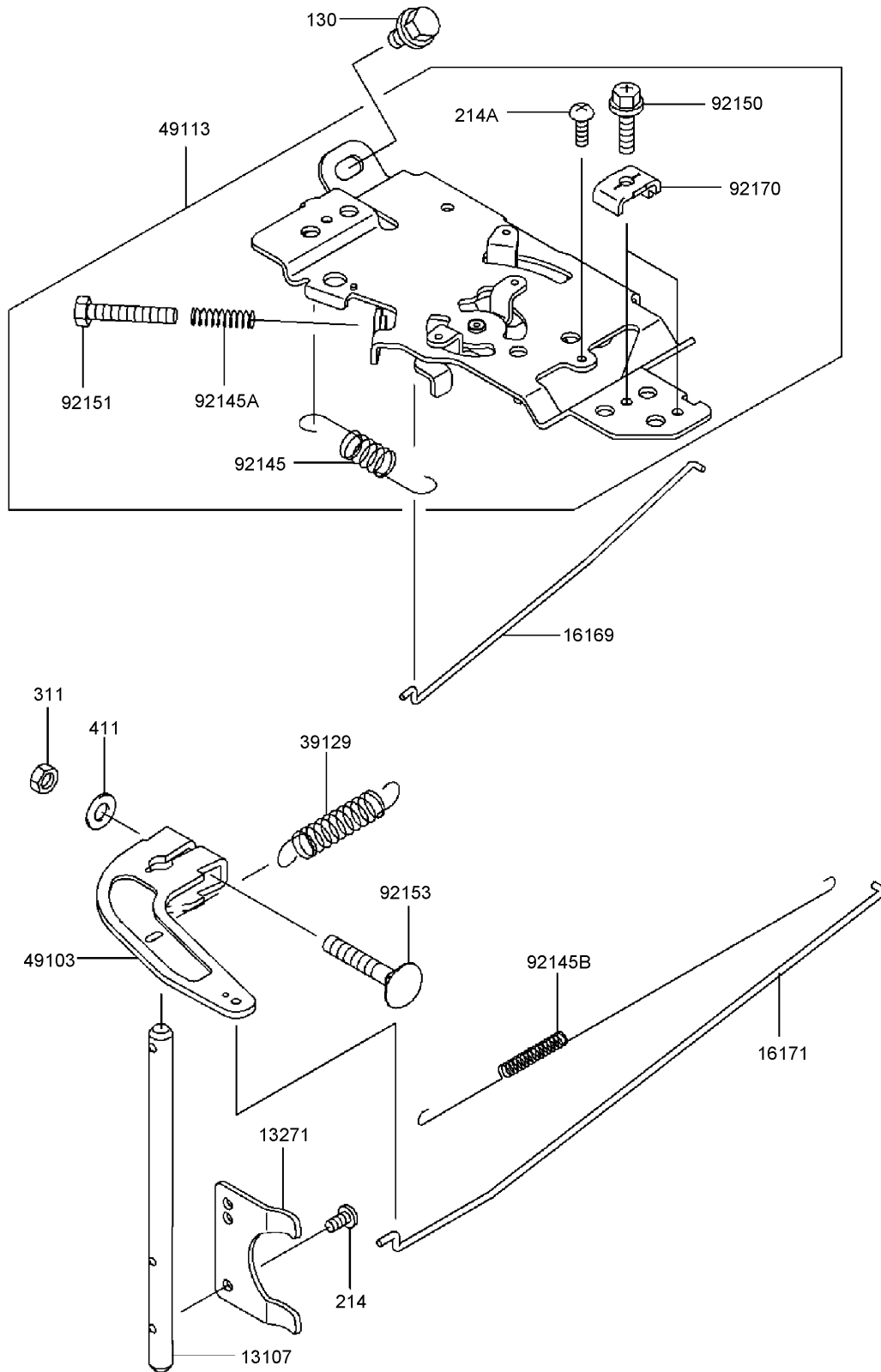

## Control Equipment Assembly Kawasaki FH721D-AS08

Ref	Part No.	Qty.	Description				
③13107	13107-7011	1	Shaft				
③13271	13271-7018	1	Plate				
③16169	16169-7008	1	Link-Choke				
③16171	16171-7005	1	Link				
③39129	39129-7012	1	Spring-Governor				
③49103	49103-7004	1	Arm-Governor				
③49113	49113-7023	1	Panel-Control				
③92145	92145-7004	1	Spring				
③92145A	92145-7005	1	Spring				
③92145B	92145-7014	1	Spring				
③92150	92150-2182	2	Bolt (5X18)				
③92151	92151-7014	1	Bolt (5X30)				
③92153	92153-7005	1	Bolt (6X35)				
③92170	92170-7001	2	Clamp				
③130	130B0612	2	Bolt-Flanged (6X12)				
③214	214B0408	2	Screw-Pan (4X8)				
③214A	214B0412	1	Screw-Pan				
③311	311B0600	1	Nut-Hex (6Mm)				
③411	411B0600	1	Washer-Plain (6Mm)				

# Carburetor Assembly Kawasaki FH721D-AS08

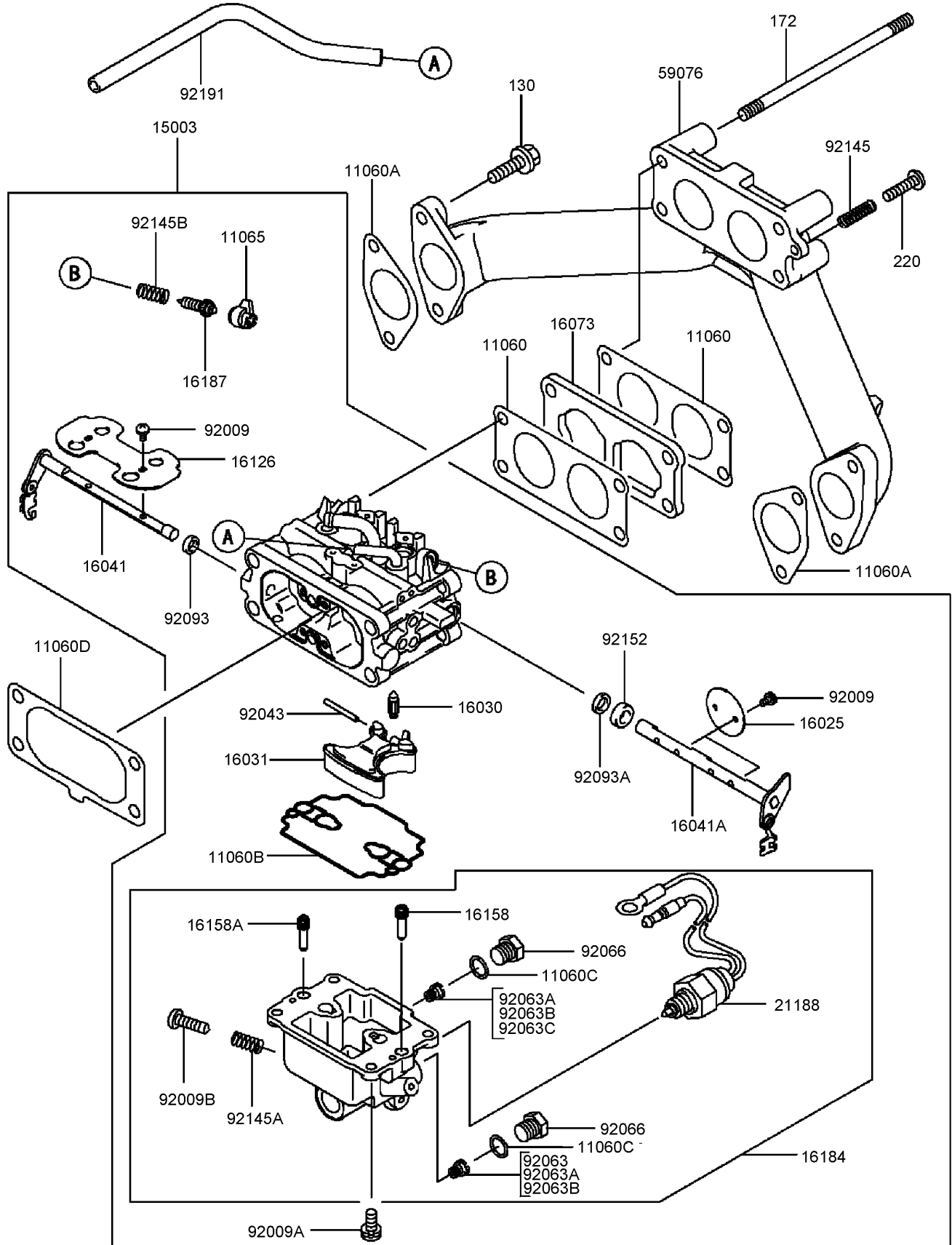

## Carburetor Assembly Kawasaki FH721D-AS08

Ref	Part No.	Qty.	Description				
③11060	11060-7010	2	Gasket-Carburetor				
③11060A	11060-7011	2	Gasket-Manifold				
③11060B	11060-7018	1	Gasket-Chamber, Float				
③11060C	11060-7019	2	Gasket-Plug, Main				
③11060D	11060-7025	1	Gasket-Filter, Air				
③11065	11065-7004	2	Cap-Limiter				
③15003	15003-7088	1	Carburetor ASM				
③16025	16025-7002	2	Valve-Throttle				
③16030	16030-7002	1	Valve-Float				
③16031	16031-7001	1	Float				
③16041	16041-7011	1	Shaft-Carburetor				
③16041A	16041-7012	1	Shaft-Carburetor				
③16073	16073-7003	1	Insulator				
③16126	16126-7004	1	Valve-Choke				
③16158	16158-7004	1	Jet-Slow, No. 54				
③16158A	16158-7010	1	Jet-Slow, No. 52				
③16184	16184-7016	1	Float Chamber ASM				
③16187	16187-7003	2	Needle-Jet				
③21188	21188-7001	1	Solenoid				
③59076	59076-7006	1	Manifold-Intake				
③92009	92009-7003	6	Screw				
③92009A	92009-7005	4	Screw				
③92009B	92009-7006	1	Screw-Drain				
③92043	92043-7004	1	Pin-Float				
③92063	92063-7012	1	Jet-Main, No. 108				
③92063A	92063-7013	2	Jet-Main, No. 105				
③92063B	92063-7014	2	Jet-Main, No. 102				
③92063C	92063-7045	1	Jet-Main, No. 112				
③92066	92066-7008	2	Plug-Jet, Main				
③92093	92093-7001	1	Seal (D=5.9)				
③92093A	92093-7002	1	Seal (D=6.9)				
③92145	92145-7005	1	Spring				
③92145A	92145-7011	1	Spring				
③92145B	92145-7013	2	Spring				
③92152	92152-7001	1	Collar				
③92191	92191-7010	1	Tube (4.76X7.94X160)				
③130	130B0620	4	Bolt-Flanged (6X20)				
③172	172G06105	2	Bolt-Stud				
③220	220B0520	1	Screw-Pan				

# Air Filter/Muffler Assembly Kawasaki FH721D-AS08

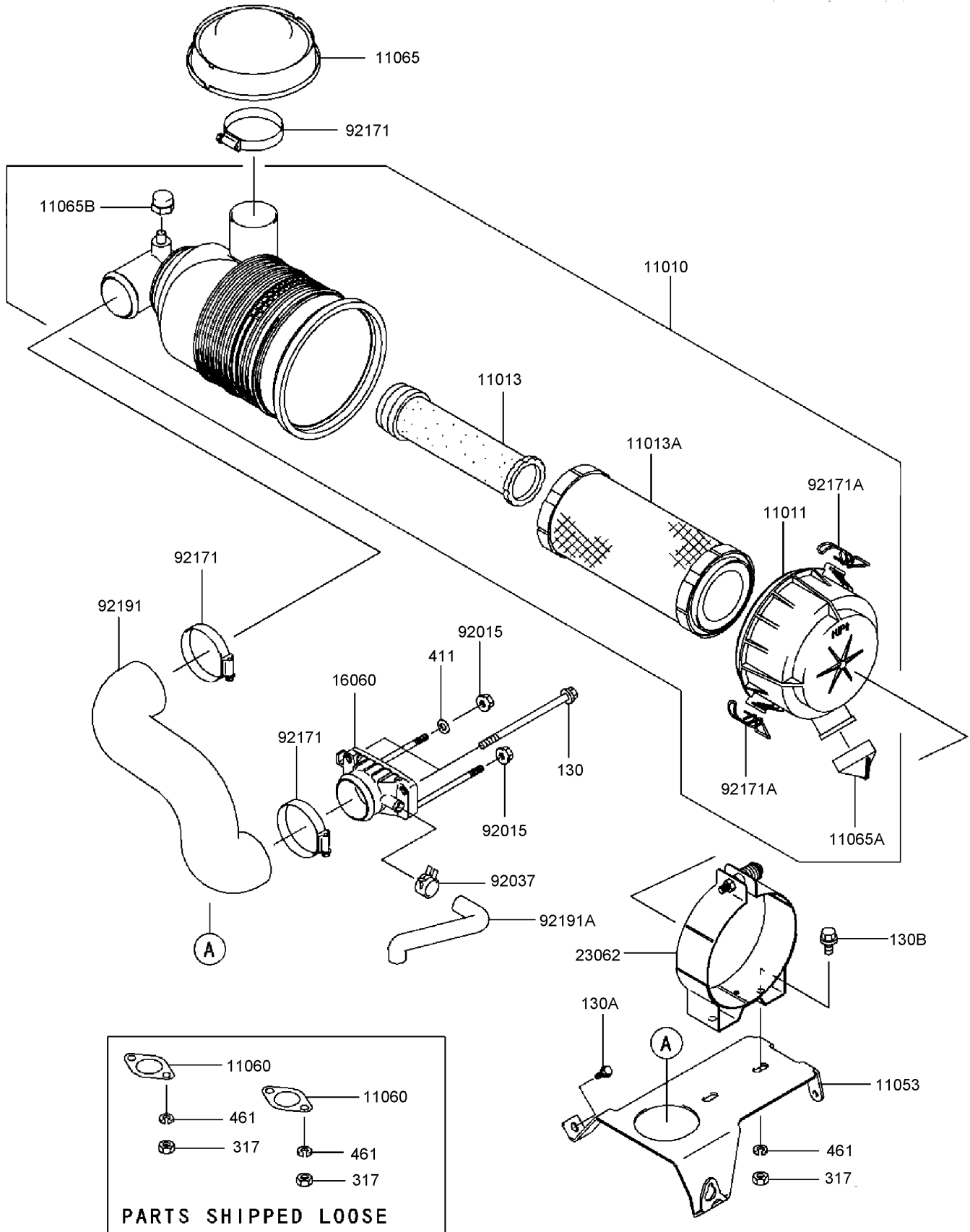

## Air Filter/Muffler Assembly Kawasaki FH721D-AS08

Ref	Part No.	Qty.	Description				
③11010	11010-7011	1	Air Filter ASM				
③11011	11011-7014	1	Case-Filter, Air				
③11013	11013-7019	1	Element-Filter, Air				
③11013A	11013-7020	1	Element-Filter, Air				
③11053	11053-7002	1	Bracket				
③11060	11060-7016	2	Gasket-Muffler				
③11065	11065-7006	1	Cap				
③11065A	11065-7008	1	Cap				
③11065B	11065-7009	1	Cap				
③16060	16060-7006	1	Pipe-Intake				
③23062	23062-7009	1	Bracket				
③92015	92015-1193	2	Nut				
③92037	92037-2079	1	Clamp				
③92171	92171-7007	3	Clamp				
③92171A	92171-7009	2	Clamp				
③92191	92191-7031	1	Tube-Intake				
③92191A	92191-7032	1	Tube-Breather				
③130	130B06105	2	Bolt-Flanged				
③130A	130B0612	2	Bolt-Flanged (6X12)				
③130B	130B0816	2	Bolt-Flanged (8X16)				
③317	317R0800	6	Nut-Hex (8Mm)				
③411	411B0600	1	Washer-Plain (6Mm)				
③461	461F0800	6	Washer-Spring (8Mm)				

# Fuel Tank/Valve Assembly Kawasaki FH721D-AS08

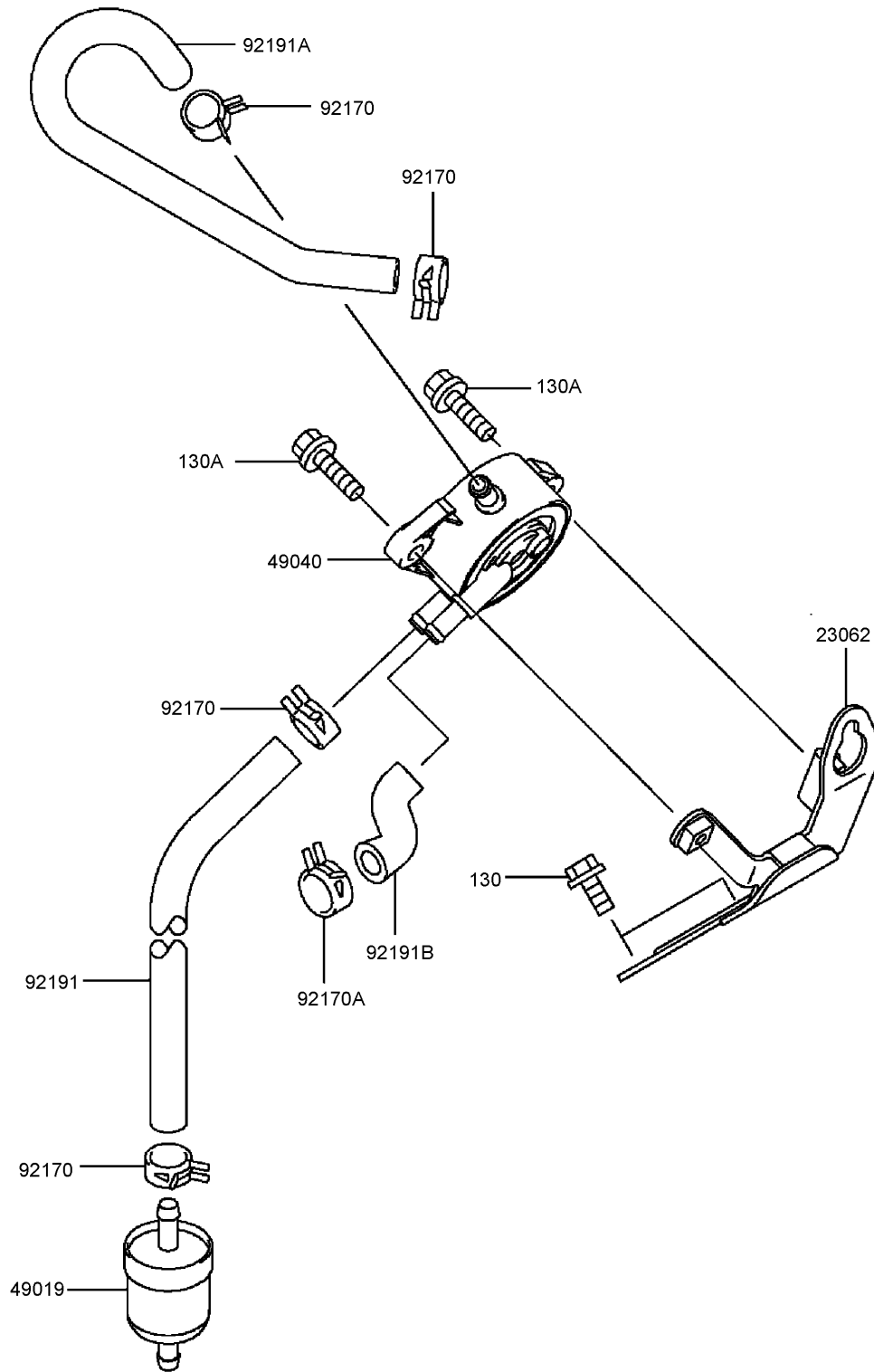

## Fuel Tank/Valve Assembly Kawasaki FH721D-AS08

Ref	Part No.	Qty.	Description				
③23062	23062-7004-9H	1	Bracket				
③49019	49019-7001	1	Filter-Fuel				
③49040	49040-7001	1	Pump-Fuel				
③92170	92170-2088	4	Clamp				
③92170A	92170-7003	1	Clamp				
③92191	92191-7003	1	Tube (6.35X12.7X160)				
③92191A	92191-7012	1	Tube				
③92191B	92191-7027	1	Tube				
③130	130B0616	2	Bolt-Flanged (6X16)				
③130A	130B0620	2	Bolt-Flanged (6X20)				

# Starter Assembly Kawasaki FH721D-AS08

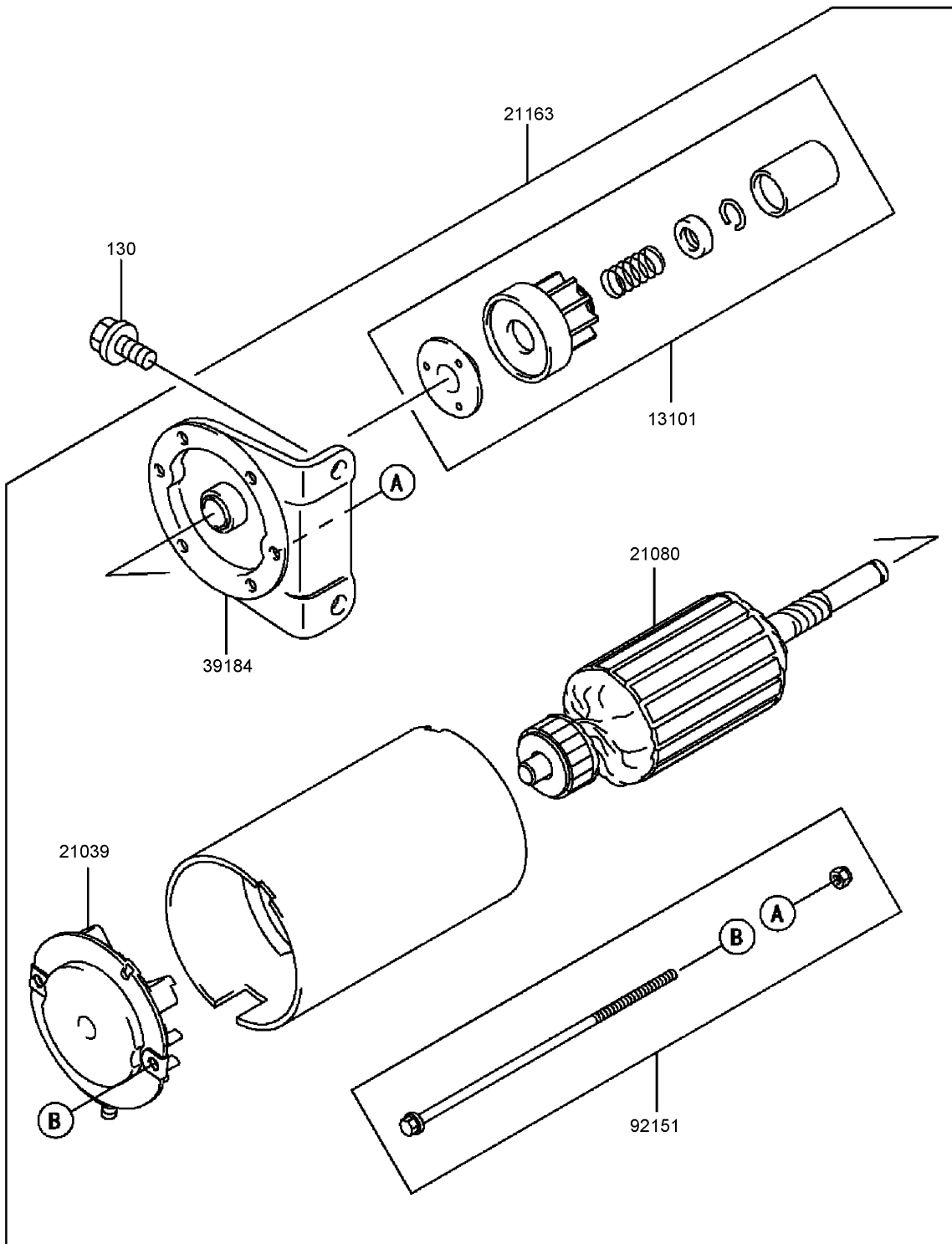

# Starter Assembly

## Kawasaki FH721D-AS08

Ref	Part No.	Qty.	Description				
⑤13101	13101-7003	1	Gear ASM				
⑤21039	21039-7004	1	Brush				
⑤21080	21080-7001	1	Armature				
⑤21163	21163-7010	1	Starter-Electric				
⑤39184	39184-7004	1	Bracket ASM				
⑤92151	92151-7013	1	Bolt				
⑤130	130B0816	2	Bolt-Flanged (8X16)				



56080



56033

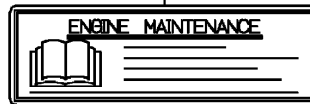

56070



**Labels**

**Kawasaki FH721D-AS08**

Ref	Part No.	Qty.	Description				
●56033	56033-7001	1	Label-Manual				
●56070	56070-7001	1	Label-Warning				
●56080	56080-7018	1	Label-Brand				

## Attachments and Accessories

### For 74248 - Z500 Z Master, With 52in 7-Gauge Side Discharge Mower

Product Name	Model/Part
Z Stand Kit	105-1622
Blade-Recycler, 18 Inch	105-7779-03
Blade-Hi Flow, 18 Inch	105-7781-03
Blade-Med Flow, 18 Inch	105-7794-03
Blade-Low Flow, 18 Inch	105-7795-03
Blade-Atomic, 18 Inch	105-7796-03
52 Inch Recycler Kit	107-1610
Striping Kit	107-1630
Turbo Baffle Kit	107-1634
Deluxe Suspension Seat	107-1891
Suspension Kit for Standard Seat	107-1892
Sunshade-Bimini	110-5726
Discharge Side Anti-Scalp Roller Kit	112-1792
52 Inch Twin Soft Bagger	78498
52 Inch TURBO FORCE Mower Finishing Kit	78512
DFS Vac Collection System	78513
Filter Minder Gauge	99-4664
Hitch Kit	99-8925

# NOTES

