



Z593-D Z Master[®] With 52 Rear Discharge Mower

Model No. 74279TE - 270000001 and up.

Parts Catalog

Ordering Replacement Parts

To order replacement parts, please supply the part number, the quantity, and the description of each part desired.

Understanding Reference Numbers

Each identified part in an illustration has a reference number. The reference number for a part also appears in the parts list, along with other information about the part.

This catalog uses two special reference number formats, one to indicate parts in a service assembly and another to indicate the quantity of a given part in an illustration.

Service Assembly Reference Numbers

Parts in service assemblies have reference numbers in the form a:b. The a represents the reference number of the entire service assembly and the b represents a sequential number unique to each part within the service assembly.

For example, a wheel assembly might be identified by reference number 6, the tire by 6:1, the valve by 6:2, and the wheel by 6:3. When you order the assembly identified by reference number 6, you receive all parts identified by reference numbers 6:1, 6:2, and 6:3. However, you may also order any part individually. Reference numbers of this type appear in illustrations and in part lists.

Reference Numbers Indicating Quantity

In an illustration, if a reference number indicates more than one part, the reference number has the form nX y. The n represents the quantity of the part, the X is the multiplication symbol, and the y represents the reference number.

For example, in an illustration, the reference number 2X 37 means that two of the parts identified by reference number 37 are indicated.

Contents

Description	Page	Description	Page
Front Frame Assembly 4	Oil Pan Assembly 31
Caster Wheel and Fork Assembly 6	Cylinder Head Assembly 32
Traction Frame and Floor Pan Assembly 7	Gear Case and Oil Filter Cartridge Assembly 33
Seat and Roll-Over Protection System Assembly 8	Head Cover Assembly 34
Deluxe Seat Assembly No. 110-0838 9	Dipstick, Guide and Oil Pump Assembly 35
Roll-Over Protection System Assembly No. 110-0877 10	Main Bearing Case Assembly 36
Parking Brake and Wheel Assembly 11	Camshaft and Idle Gear Shaft Assembly 37
Hydro Control Assembly 12	Piston and Crankshaft Assembly 38
Engine, Exhaust and Air Intake Assembly 13	Flywheel, Fuel Camshaft and Governor Shaft Assembly 39
Air Cleaner Assembly No. 93-2190 14	Idle Apparatus and Stop Solenoid Assembly 40
Hydro and Gearbox Assembly 15	Injection Pump and Governor Assembly 41
Gearbox Assembly No. 107-9887 16	Speed Control Plate Assembly 42
Hydraulic Tank, Motor and Pump Assembly 17	Nozzle Holder and Glow Plug Assembly 43
Tandem Pump Assembly No. 107-9885 19	Nozzle Holder Assembly 44
Throttle, Control Panel and Fuel Tank Assembly 20	Fuel Pump and Fuel Filter Assembly 46
Engine Housing Assembly 21	Alternator, Pulley and Fuel Pump Cover Assembly 47
Cooling System Assembly 22	Alternator Assembly 48
Hood Assembly 23	Starter Installation Assembly 49
Deck Connection Assembly 24	Starter Assembly 50
Deck Assembly 25	Water Flange, Pump, Pipe and Thermostat Assembly 51
Deck Decal Assembly No. 112-3751 26	Valve and Rocker Arm Assembly 52
Spindle Assembly No. 108-7713 27	Inlet and Exhaust Manifold Assembly 53
Spring Idler Assembly No. 114-1812 28	Gasket Kit 54
Electrical Assembly 29	Piston Kit 55
Crankcase Assembly 30	Attachments and Accessories List 56

Part Description Abbreviations

Part descriptions in this catalog may include the following abbreviations.

AR.	as required	HYD.	hydraulic
ASM.	assembly	LH.	left hand
BBC.	blade brake clutch	NI.	nylon insert
CARR.	carriage	NPTF.	national pipe thread fine
DEG.	degrees	PFH.	phillips flat head
EXT.	external	PPH.	phillips pan head
FH.	flat head	PPHTF.	phillips pan head thread forming
GA.	gauge	PRH.	phillips round head
HD.	heavy-duty	PTH.	phillips truss head
HF.	hex flange	PTO.	power-take-off
HH.	hex head	RH.	right hand
HHF.	hex head flange	ROPS.	roll-over protection system
HHFTF.	hex head flange thread forming	SFH.	slotted fillister head
HJ.	hex jam	SHH.	slotted hex head
HLH.	hex lag head	SHWH.	slotted hex washer head
HOC.	height-of-cut	SPH.	slotted pan head
HSBH.	hex socket button head	SQH.	square head
HSFH.	hex socket flat head	SRH.	slotted round head
HSH.	hex socket head	STD.	standard
HWH.	hex washer head	TAP.	self tapping
HWHTF.	hex washer head thread forming	TTH.	torx truss head

Footnotes

❶ Not illustrated

❷ Not serviced separately

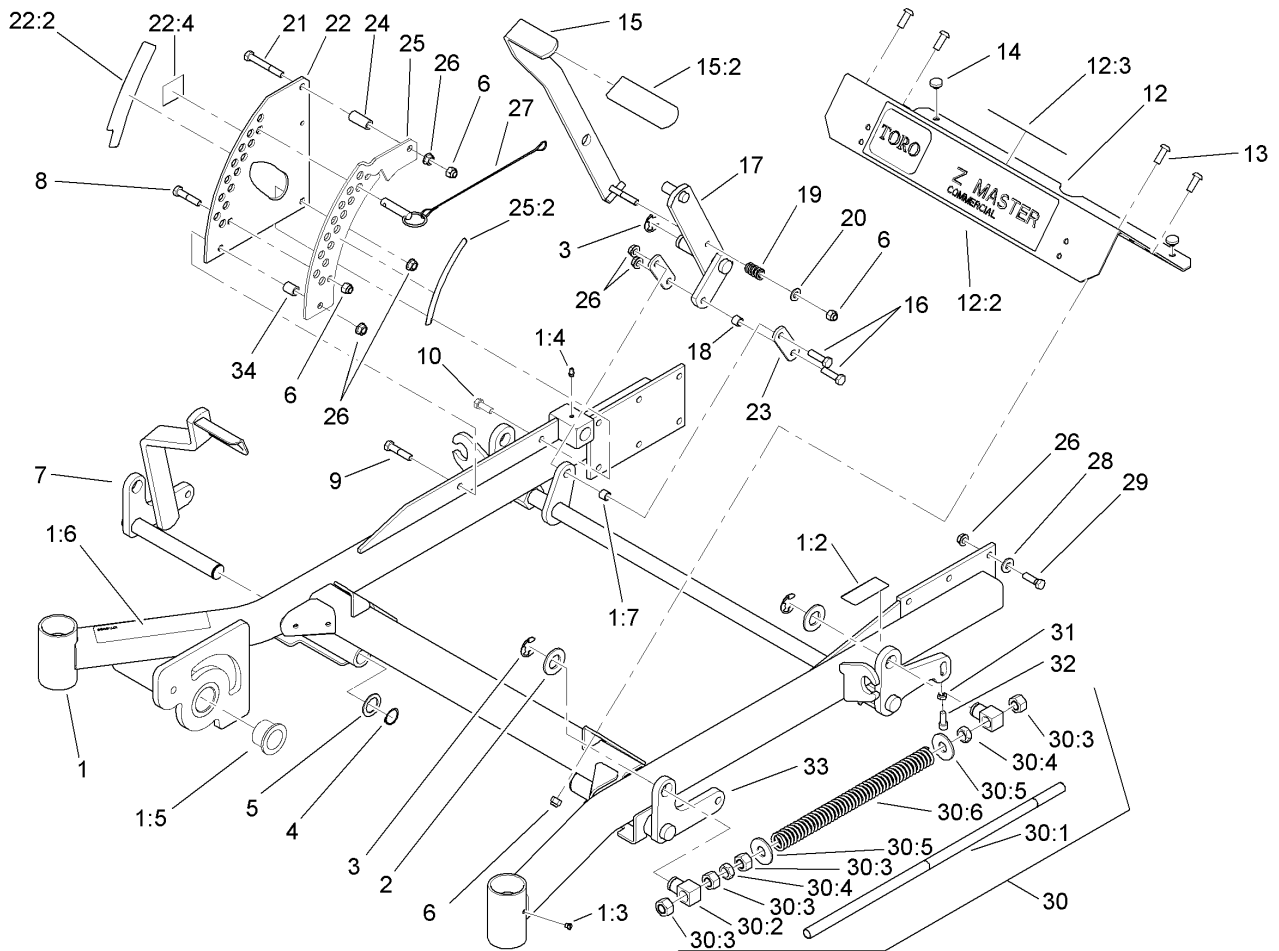

Front Frame Assembly

Ref	Part No.	Qty.	Description
1	110-0800	1	Frame ASM
1:2	107-3968	1	Decal-Brake, Parking
1:3	1-811010	2	Plug
1:4	302-19	5	Fitting-Grease
1:5	94-1291	2	Bushing
1:6	107-3969	1	Decal-Warning
1:7	103-1918	1	Bushing
2	3256-29	4	Washer-Flat
3	32151-103	5	Ring-Snap
4	32151-29	2	Ring-Retaining
5	1-523157	2	Washer-Spacer
6	3296-39	7	Nut-Lock, NI
7	108-7786-01	1	RH Front Deck Lift ASM
8	323-9	1	Screw-HH
9	323-10	1	Screw-HH
10	323-6	1	Screw-HH
12	107-3976	1	Footrest
12:2	106-7451	1	Decal
12:3	107-1866	1	Decal-Danger, Slope
13	3274-94	4	Screw-HSBH
14	1-513658	2	Bumper
15	103-2084	1	Lift Lever/Grip ASM
15:2	1-633295	1	Grip-Lever, Lift
16	323-29	2	Screw-HH

Ref	Part No.	Qty.	Description
17	103-2064-03	1	Arm-Lift, Deck
18	103-1918	1	Bushing
19	1-633325	1	Spring-Compression
20	3256-24	1	Washer-Flat
21	323-13	1	Screw-HH
22	110-0835	1	Plate-Deck Lift, Outer (Ce)
22:2	107-3961	1	Decal-Deck Height, Large
22:4	105-4674	1	Decal-Noise
23	1-633068	2	Arm-Lift, Deck
24	1-633082	1	Bushing-Lever, Lift
25	110-0836	1	Plate-Deck Lift, Inner (Ce)
25:2	107-3962	1	Decal-Deck Height, Small
26	3290-357	17	Nut-HHF, Whiz
27	106-9951	1	Hitch Pin ASM
28	98-5975	12	Washer-Belleville
29	323-7	12	Screw-HH
30		2	Front Frame Spring ASM
30:1	1-633096	1	Rod-Lift, Deck
30:2	1-633441	2	Swivel-Deck Mount, Rear
30:3	3217-11	4	Nut-Hex
30:4	3218-6	2	Nut-Jam
30:5	3256-7	2	Washer-Flat
30:6	1-633064	1	Spring-Support, Deck
31	3218-2	2	Nut-Jam

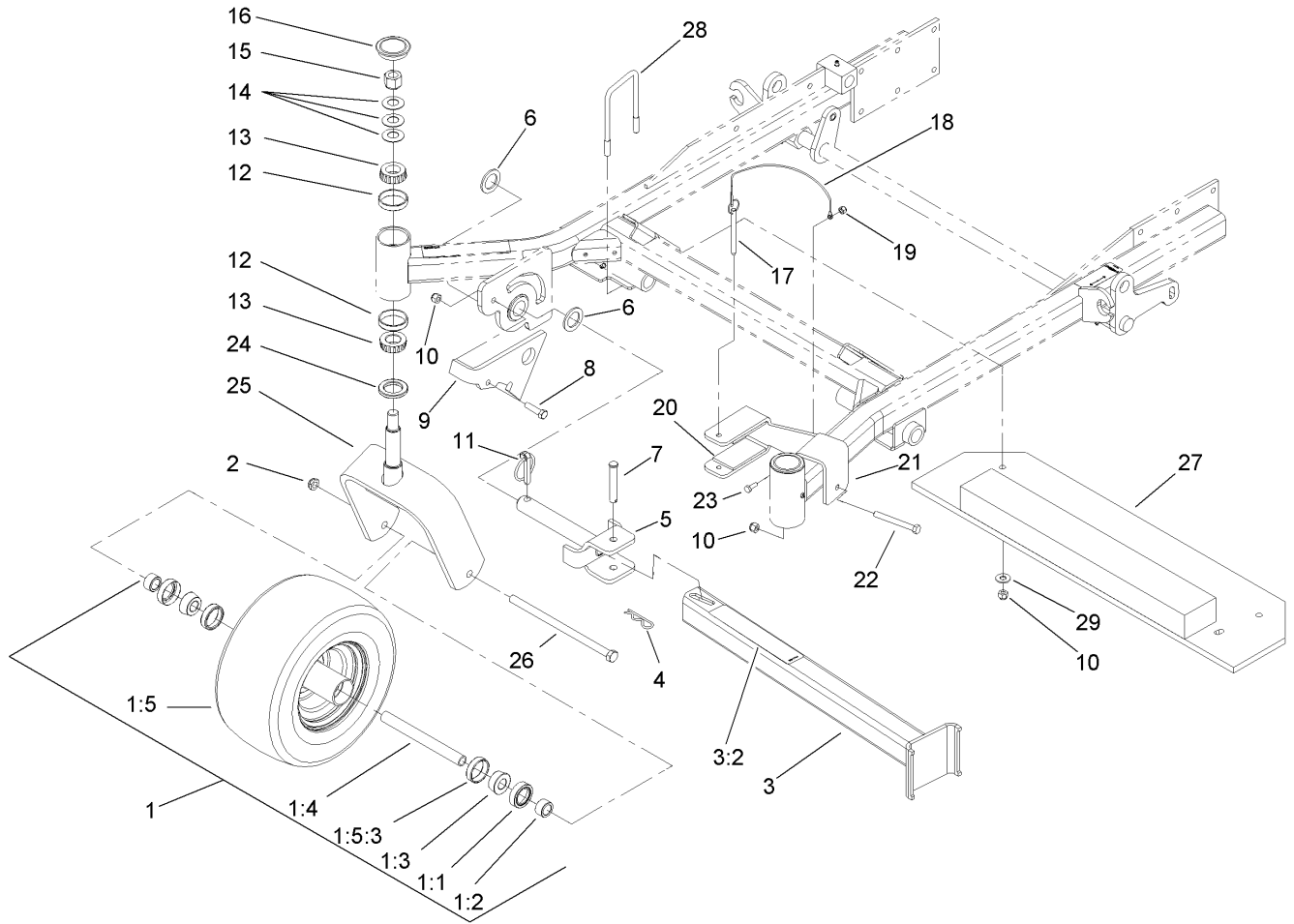

Caster Wheel and Fork Assembly

Ref	Part No.	Qty.	Description
②1		2	Castor Wheel ASM (Semi-Pneumatic)
1:1	1-633580	2	Seal-Bearing
1:2	1-633581	2	Spacer-Bearing
1:3	1-633585	2	Bearing-Cone, Taper
1:4	1-633959	1	Spacer-Caster, Front
②1:5		1	Wheel And Tire ASM (Semi-Pneumatic)
1:5:3	1-633584	1	Bearing-Cup
2	3296-23	2	Nut-Lock, NI
3	107-1874	1	Leg ASM
3:2	106-7464	1	Decal-Z Stand
4	3290-355	1	Pin-Hair
5	100-9692-01	1	Pivot Pin ASM
6	3-6781	2	Washer-Thrust
7	283-55	1	Pin-Clevis
8	323-8	1	Screw-HH
9	100-9686-01	1	Bracket-Latch
10	3296-39	6	Nut-Lock, NI
11	283-71	1	Pin-Lynch
12	254-72	4	Bearing-Cup, Tapered
13	254-94	4	Bearing-Cone, Tapered
14	1-633508	6	Washer-Bellville
15	3296-51	2	Nut-Lock, NI

Ref	Part No.	Qty.	Description
16	103-4882	2	Cap-Grease
17	105-1647	1	Pin-Hitch, Cotterless
18	100-9385	1	Lanyard-Nylon
19	3296-42	1	Nut-Lock, NI
20	100-6547	2	Cushion-Rubber
21	100-6542-01	1	Bracket-Cradle
22	323-20	1	Screw-HH
23	321-4	1	Screw-HH
24	1-543511	2	Seal-Grease
25	1-642111-01	2	Caster
26	325-24	2	Screw-HH
27	107-9874-01	1	Weight ASM
28	110-0817	2	U-Bolt, 3 Inch
29	3256-4	4	Washer-Flat

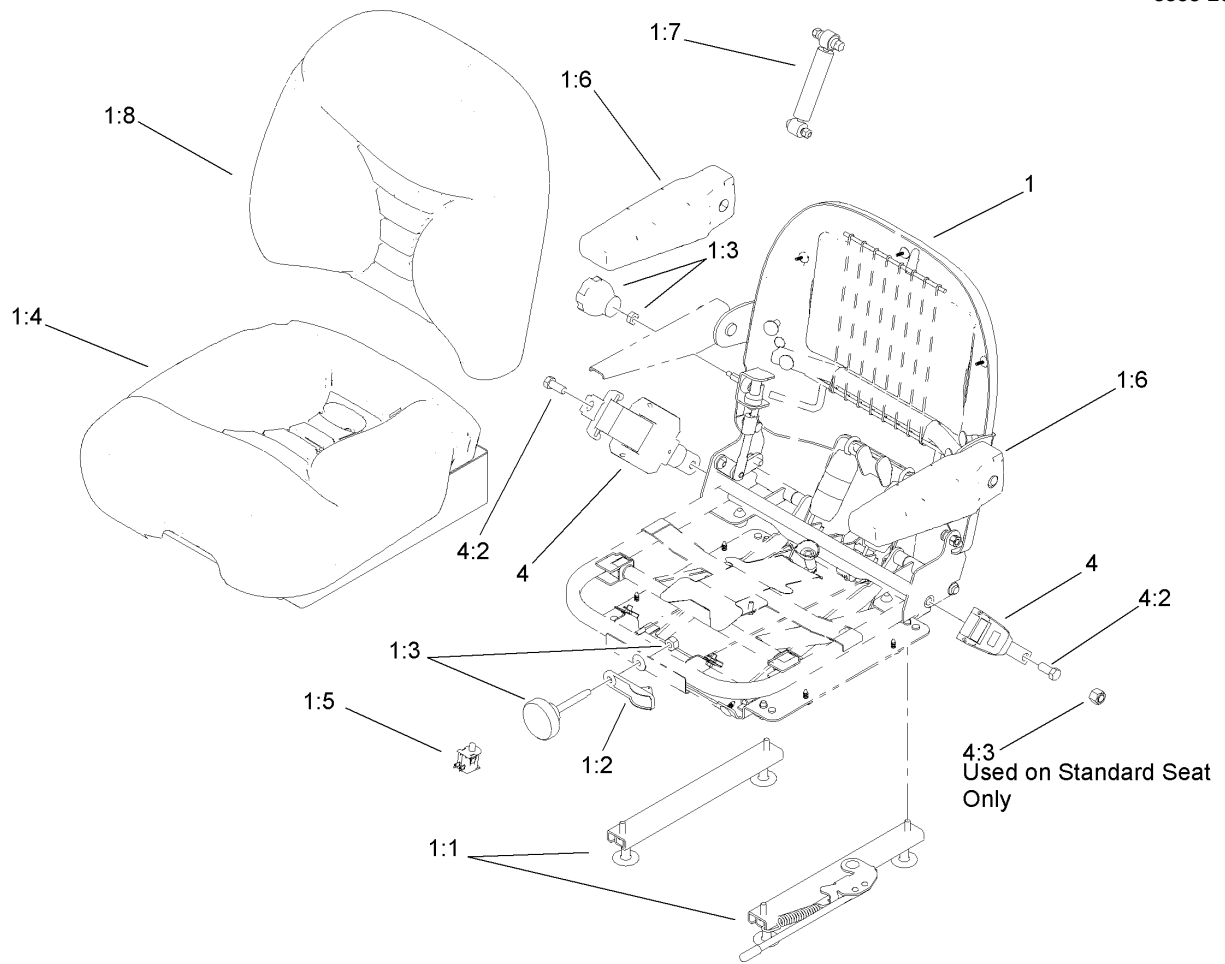

Deluxe Seat Assembly No. 110-0838

Ref	Part No.	Qty.	Description
①		1	Seat ASM
1:1	107-1880	1	Seat Track Kit
1:2	107-1885	1	Weight Indicator Kit
1:3	107-1881	1	Knob Kit
1:4	107-1883	1	Bottom Cushion Kit
1:5	107-1886	1	Switch Kit
1:6	107-1887	1	Armrest Kit
1:7	107-1884	1	Shock Absorber Kit
1:8	107-1882	1	Back Cushion Kit
4	110-0883	1	Retractable Seatbelt Kit
4:2	3212-4	2	Screw-HH
4:3	3296-7	2	Nut-Lock

--	--	--	--

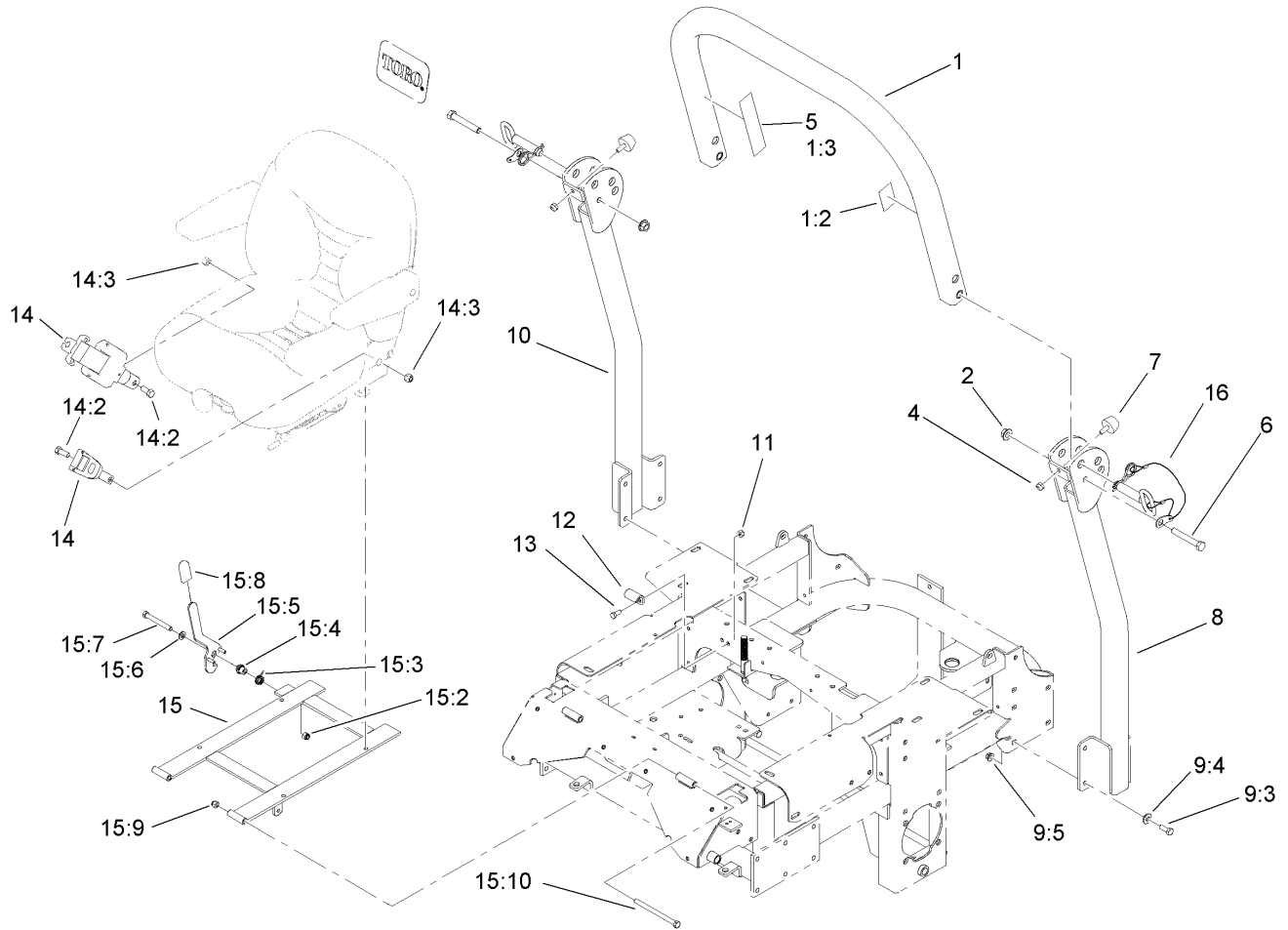

Roll-Over Protection System Assembly No. 110-0877

Ref	Part No.	Qty.	Description
②1		1	Upper Tube ASM
1:2	107-2101	1	Decal-ROPS
1:3	107-2102	1	Decal-Warning, Folding ROPS
2	32128-23	2	Nut-HF
4	3296-73	2	Nut-Lock, NI
5	107-3069	1	Decal-Warning, Folding ROPS (Ce)
6	325-13	2	Screw-HH
7	109-2365	2	Bumper-Rubber (W/Stud)
②8		1	Tube-Support, LH
①9		1	Bag-Bolt, ROPS
9:3	323-6	8	Screw-HH
9:4	98-5975	8	Washer-Belleville
9:5	3290-357	8	Nut-HHF, Whiz
②10		1	Tube-Support, RH
11	3296-29	2	Nut-Lock, NI
12	107-3058	1	Catch-Latch, Seat
13	322-3	2	Screw-HH
14	110-0883	1	Retractable Seatbelt Kit
14:2	3212-4	2	Screw-HH
14:3	3296-7	2	Nut-Lock
15	110-0874	1	Seatframe ASM
15:2	3296-39	1	Nut-Lock, NI
15:3	107-0076	1	Spring-Torsion

Ref	Part No.	Qty.	Description
15:4	107-0075	1	Bushing-Latch, Seat
15:5	107-3083	1	Latch ASM
15:6	3256-24	1	Washer-Flat
15:7	323-20	1	Screw-HH
15:8	103-4434	1	Grip-Lever
15:9	3296-39	2	Nut-Lock, NI
15:10	323-39	2	Screw-HH
16	103-4553	2	ROPS Fold Pin ASM

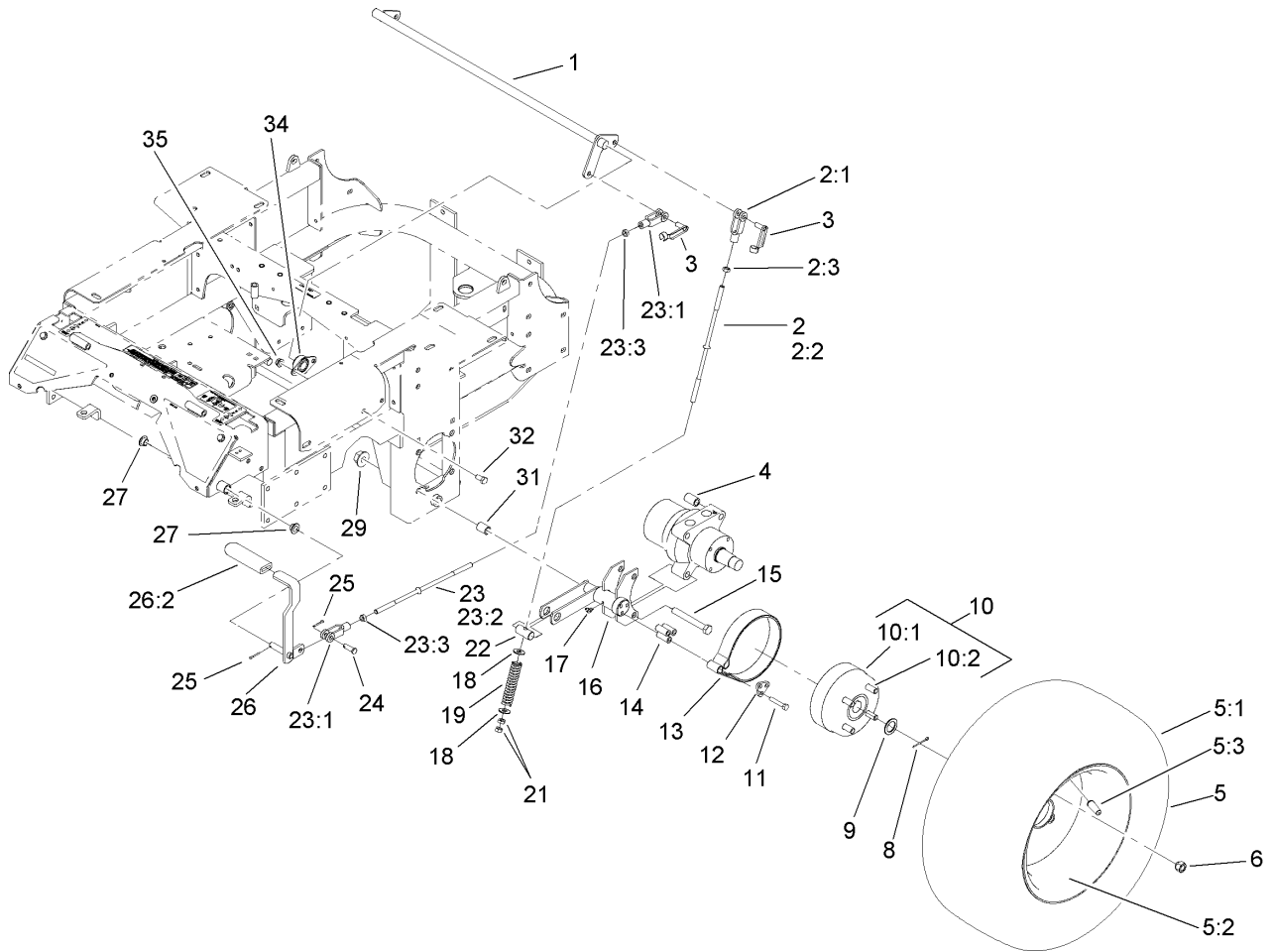

Parking Brake and Wheel Assembly

Ref	Part No.	Qty.	Description
1	1-632217-03	1	Shaft-Brake
2	108-5963	2	Brake Rod ASM
2:1	1-633131	1	Yoke-Linkage, Brake
2:2	108-5980	1	Rod, Brake
2:3	3219-3	1	Nut-Hex
3	103-2399	3	Pin-Spring, Clevis
4	1-633382	4	Spacer-Wheel, Long
5	1-653010	2	Wheel And Tire ASM
5:1	1-653160	1	Tire
5:2	1-653158	1	Wheel
5:3	232-27	1	Stem-Valve
6	242-50	8	Nut-Lug
8	1-806800	2	Pin-Cotter
9	1-523157	2	Washer-Spacer
10	103-0590	2	Hub And Wheel ASM
10:1	103-0589	1	Wheel Hub ASM
10:2	1-633926	4	Stud-Wheel
11	322-9	6	Screw-HH
12	103-0374	2	Retainer-Band, Brake
13	103-0355	2	Band-Brake
14	103-0384	6	Spacer
15	325-17	8	Screw-HH
16	103-0352-03	2	Bracket-Brake
17	1481	2	Fitting-Grease

Ref	Part No.	Qty.	Description
18	3256-4	4	Washer-Flat
19	1-633454	2	Spring-Brake
21	3219-3	4	Nut-Hex
22	1-633144	2	Pin-Trunion
23	108-5962	1	Brake Rod ASM
23:1	1-633131	2	Yoke-Linkage, Brake
23:2	1-633477	1	Rod-Brake
23:3	3219-3	2	Nut-Hex
24	1-808285	1	Pin-Clevis
25	3272-10	2	Pin-Cotter
26	1-634500	1	Brake Lever ASM
26:2	1-633268	1	Grip-Lever, Brake
27	1-513140	2	Bearing-Control
29	32128-49	8	Nut-HHF
31	1-633380	4	Spacer-Wheel, Short
32	323-4	4	Screw-HH
34	1-633102	2	Bearing-Flange, Side
35	3290-357	4	Nut-HHF, Whiz

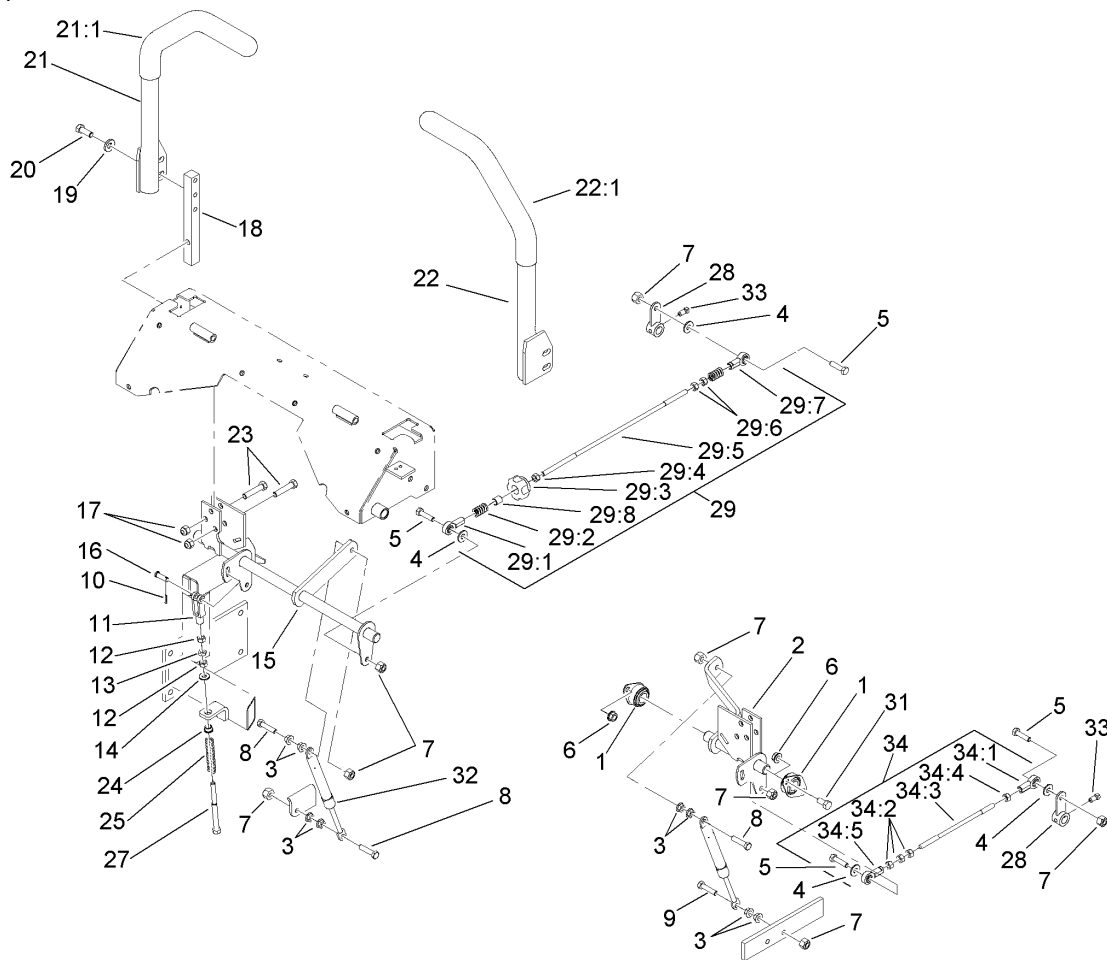

Hydro Control Assembly

Ref	Part No.	Qty.	Description
1	1-633102	4	Bearing-Flange, Side
2	107-3480	1	LH Motion Control ASM
3	32128-20	10	Nut-HF
4	3256-3	4	Washer-Flat
5	322-6	4	Screw-HH
6	3290-357	6	Nut-HHF, Whiz
7	3296-29	8	Nut-Lock, NI
8	1-403180	3	Screw-HH
9	322-41	1	Screw-HH
10	3272-5	2	Pin-Cotter
11	1-303105	2	Yoke-Adjustable
12	3219-2	4	Nut-Hex
13	3220-2	2	Nut-Jam
14	3256-2	2	Washer-Flat
15	107-3481	1	RH Motion Control ASM
16	1-808280	2	Pin-Clevis
17	3296-39	6	Nut-Lock, NI
18	103-0407	2	Arm-Shaft, Control
19	98-5975	4	Washer-Belleville
20	323-6	4	Screw-HH
21	108-7237	1	RH Lever ASM
21:1	106-9987	1	Grip-Control, Motion
22	108-7238	1	LH Lever ASM
22:1	106-9987	1	Grip-Control, Motion

Ref	Part No.	Qty.	Description
23	323-9	6	Screw-HH
24	1-603735	2	Bushing-Flanged
25	1-603807	2	Spring-Return, Neutral
27	1-603737	2	Bolt-Return, Neutral
28	107-3470-03	2	Hydraulic Control Arm ASM
29		1	RH Control Rod ASM
29:1	1-543017	1	Balljoint-RH
29:2	1-323245	2	Spring-Compression
29:3	103-3060	1	Knob-Tracking
29:4	3219-2	1	Nut-Hex
29:5		1	Rod-Control, RH
29:6	1-804524	2	Nut
29:7	1-633152	1	Balljoint-LH
29:8	103-1166	1	Spacer-Tube, Pump Link
31	323-4	6	Screw-HH
32	109-2339	2	Damper-Control, Motion
33	1-803022	2	Screw-Set
34		1	LH Control Rod ASM
34:1	1-543017	1	Balljoint-RH
34:2	3219-2	3	Nut-Hex
34:3		1	Rod-Control, LH
34:4	1-804524	1	Nut
34:5	1-633152	1	Balljoint-LH

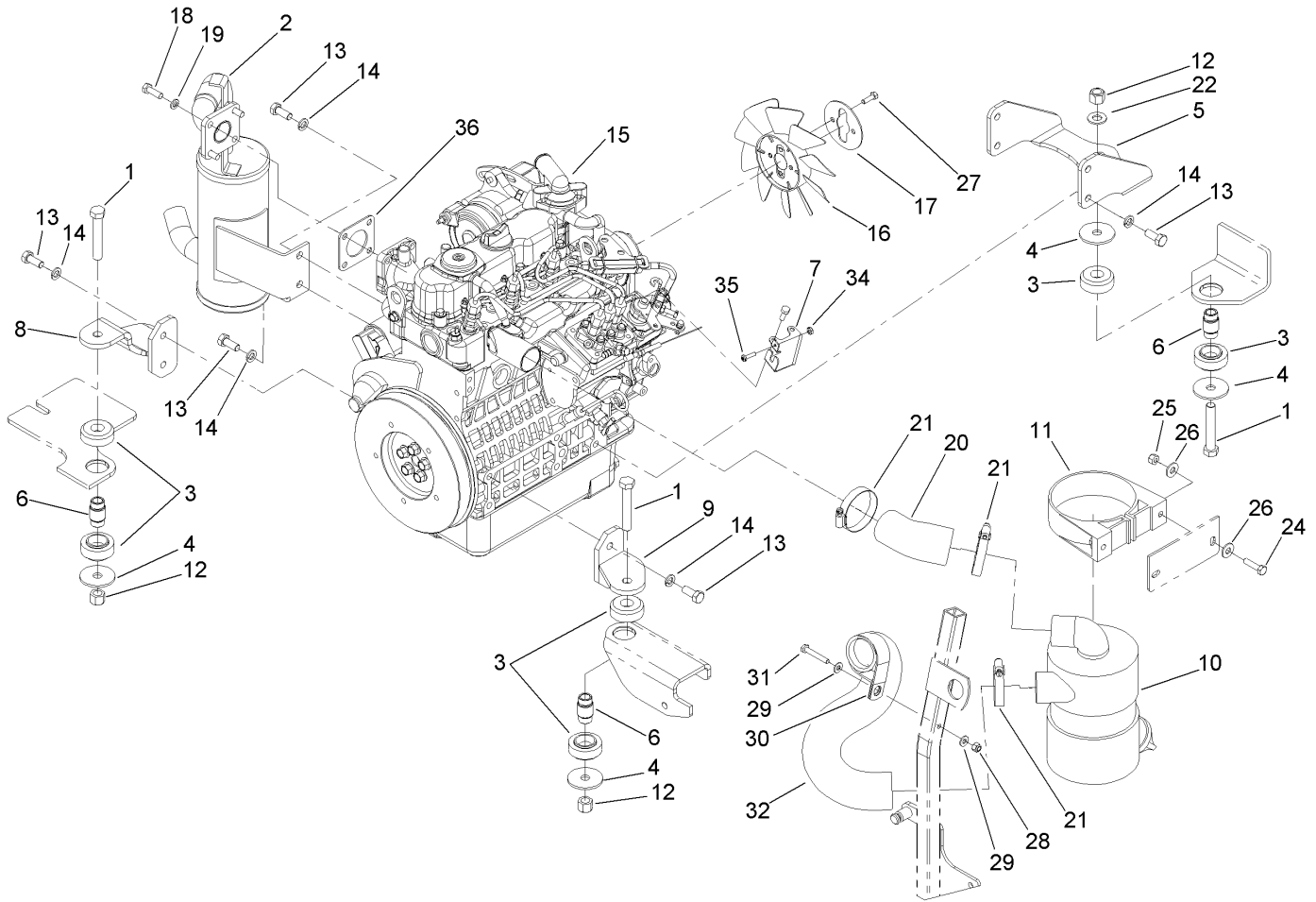

Engine, Exhaust and Air Intake Assembly

Ref	Part No.	Qty.	Description
1	325-12	3	Screw-HH
2	107-9909	1	Muffler
3	107-9914	3	Mount-Isolation
4	55-7960	4	Washer-Blade, Large
5	107-9917-03	1	Bracket-Engine Mount, Rear
6	110-0300	3	Spacer
7	108-5922	1	Bracket-Support, Throttle
8	107-9920-03	1	RH Engine Support ASM
9	107-9930-03	1	LH Engine Support ASM
10	93-2190	1	Air Cleaner ASM
11	95-5806	1	Bracket-Mounting
12	3296-23	3	Nut-Lock, NI
13	43-0090	10	Screw-HH
14	42-9600	10	Washer-Lock, Spring
15	107-9911	1	Engine-Kubota
16	110-0814	1	Fan
17	110-0816	1	Plate-Reatainer, Fan
18	33114-025	4	Screw-HH
19	3253-4	4	Washer-Lock
20	108-5371	1	Hose-Intake, Air Cleaner
21	1-643009	3	Clamp-Hose
22	3256-26	1	Washer-Flat
24	322-6	2	Screw-HH
25	3296-29	2	Nut-Lock, NI

Ref	Part No.	Qty.	Description
26	3256-23	4	Washer-Flat
27	33113-020	2	Screw-HH
28	3296-42	1	Nut-Lock, NI
29	3256-22	2	Washer-Flat
30	1-643241	1	Clip-Loom
31	321-10	1	Screw-HH
32	108-5370	1	Hose-Intake, Engine
34	3217-26	1	Nut-Hex
35	110-0863	1	Screw-Torx
36	99-8343	1	Gasket-Muffler

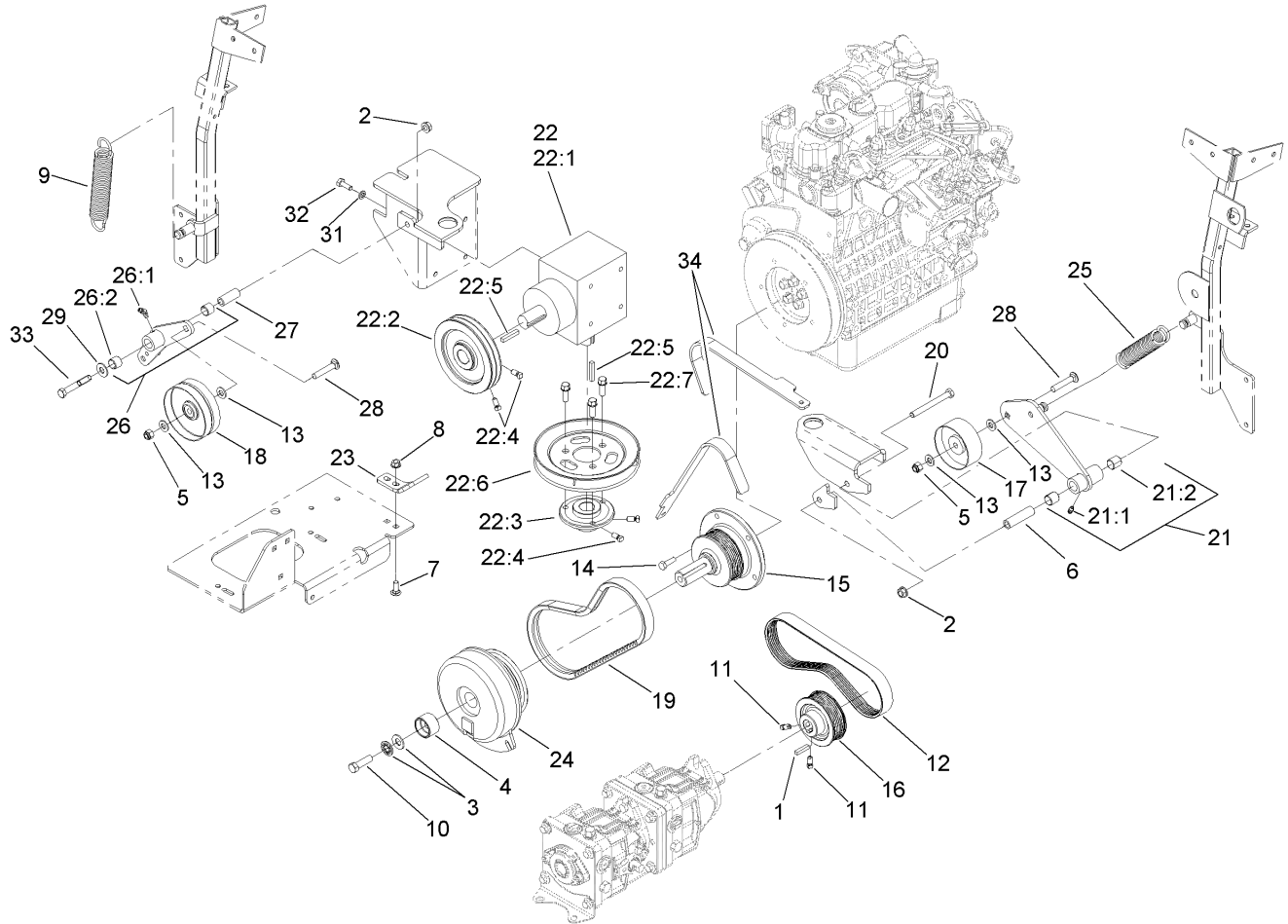

Hydro and Gearbox Assembly

Ref	Part No.	Qty.	Description
1	5-0698	1	Key
2	3290-357	2	Nut-HHF, Whiz
3	1-603610	2	Washer-Spring
4	110-0854	1	Retainer-Clutch
5	3296-39	2	Nut-Lock, NI
6	1-603384	1	Bushing-Pivot, Idler
7	3230-16	2	Screw-CARR
8	32128-25	2	Nut-HF
9	110-0818	1	Spring-Extension
10	3212-6	1	Screw-HH
11	1-803022	2	Screw-Set
12	107-9910	1	Belt-V
13	3256-24	4	Washer-Flat
14	33114-025	5	Screw-HH
15	108-5975	1	Shaft-Stub
16	108-5976	1	Pulley
17	108-5910	1	Pulley-Flat
18	110-0803	1	Pulley-Flat
19	110-0805	1	Belt-V
20	323-15	1	Screw-HH
21	108-5939	1	Pump Idler Arm ASM
21:1	302-5	1	Fitting-Grease
21:2	1-513034	2	Sleeve-Bearing
22		1	Gearbox ASM

Ref	Part No.	Qty.	Description
22:1	107-9887	1	Gearbox-90 DEG
22:2	108-5912	1	Pulley
22:3	112-3894	1	Hub-Pulley
22:4	1-803022	4	Screw-Set
22:5	67-7490	2	Key-Square
22:6	108-5979	1	Pulley-B Section
22:7	92-1624	3	Screw
23	110-0815	1	Bracket-Clutch Stop
24	110-0862	1	Clutch-Electromagnetic
25	108-5985	1	Spring-Extension
26	112-2354	1	Gearbox Idler ASM W/Bearings
26:1	1481	1	Fitting-Grease
26:2	103-4681	2	Sleeve-Bearing
27	1-603044	1	Bushing
28	3231-6	2	Screw-CARR
29	3256-4	1	Washer-Flat
31	3253-4	4	Washer-Lock
32	322-4	4	Screw-HH
33	323-12	1	Screw-HH
34	110-0876	1	Tool-Alignment, Pulley

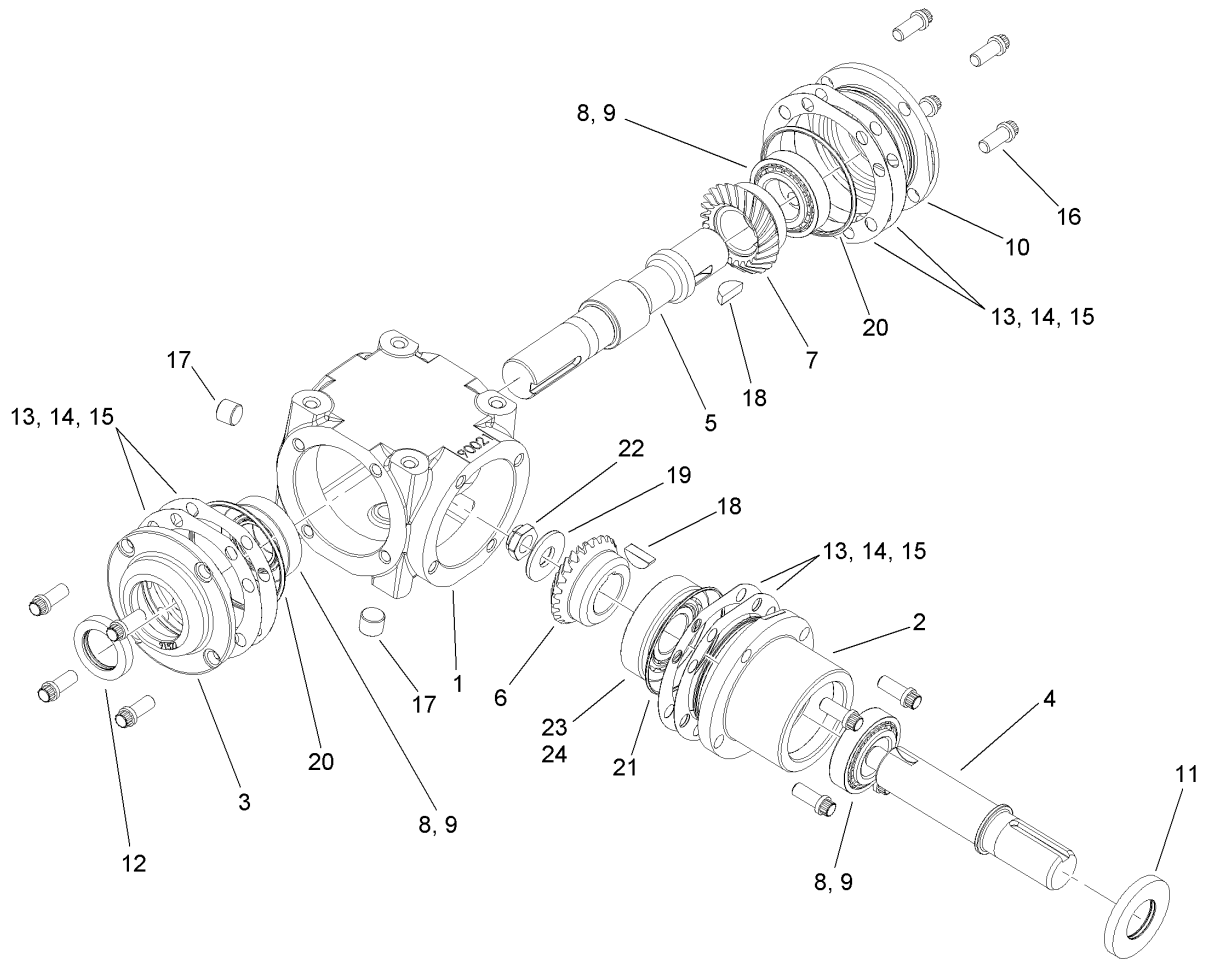

Gearbox Assembly No. 107-9887

Ref	Part No.	Qty.	Description
1	110-0843	1	Case
2	110-0853	1	Housing-Pinion
3	100-4566	1	Cap-End, Open
4	110-0844	1	Shaft-Pinion
5	110-0845	1	Shaft-Cross
6	110-0847	1	Gear-Shaft, Cross
7	110-0846	1	Gear-Pinion
8	110-0848	3	Bearing-Cup
9	110-0849	3	Bearing-Cone
10	100-4574	1	Cap-End, Closed
11	100-4575	1	Seal
12	110-0850	1	Seal-Shaft, Cross
13	100-4591	1	Shim-Brown, .010In
14	100-4592	1	Shim-Blue, .005In
15	100-4593	1	Shim-Green, .003In
16	100-4578	12	Screw
17	100-4579	2	Plug
18	3257-33	2	Key-Woodruff
19	100-4581	1	Washer
20	100-4582	2	O-Ring
21	110-0851	1	O-Ring
22	110-0852	1	Nut Lock
23	100-5817	1	Bearing-Cup
24	100-5816	1	Bearing-Cone

--	--	--	--

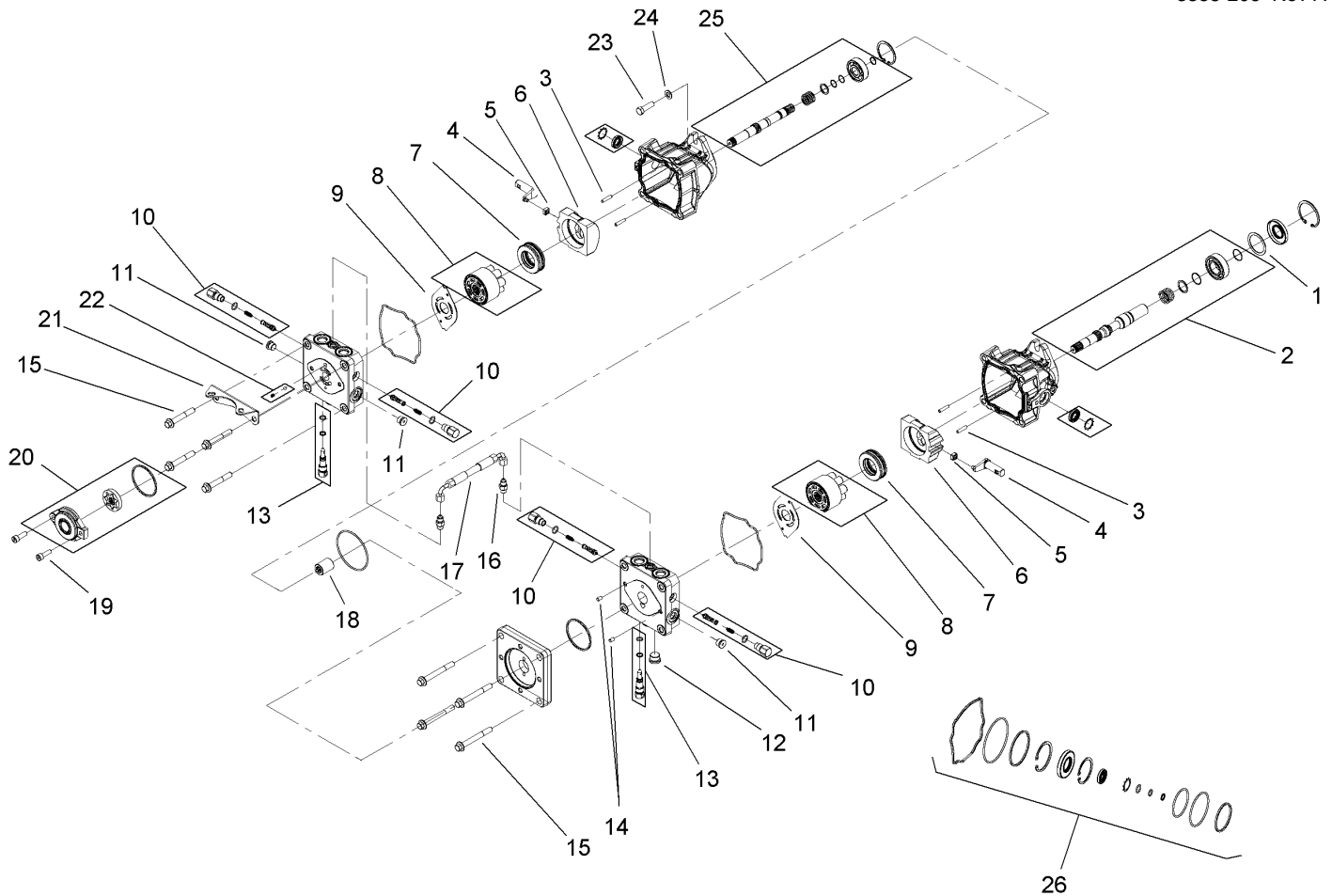

Tandem Pump Assembly No. 107-9885

Ref	Part No.	Qty.	Description
1	112-4168	1	Spacer
2	112-4151	1	Input Pump Shaft Kit
3	106-8753	4	Pin-Headless, Straight
4	112-4152	2	Arm-Trunnion
5	94-1910	2	Guide-Slot
6	112-4153	2	Swashplate
7	112-4154	2	Bearing-Thrust
8	108-2112	2	Cylinder Block Kit
9	108-6801	2	Plate-Valve
10	112-4155	4	Shock Valve Kit
11	104-2189	3	Plug-Thread, Straight
12	112-4156	1	Plug-Steel
13	106-8759	2	Bypass Valve Kit
14	104-2170	2	Pin
15	112-4157	8	Bolt
16	112-4158	2	Fitting-Straight
17	112-4159	1	Hose ASM
18	112-4160	1	Coupling
19	112-4161	2	Bolt
20	112-4162	1	Charge Pump Kit
21	112-4163	1	Bracket-Support, Pump
22	112-4164	1	Charge Relief Kit
23	112-4165	2	Bolt-HSH
24	112-4166	2	Washer

Ref	Part No.	Qty.	Description
25	112-4167	1	Second Pump Shaft Kit
26	112-4150	1	Overhaul Seal Kit

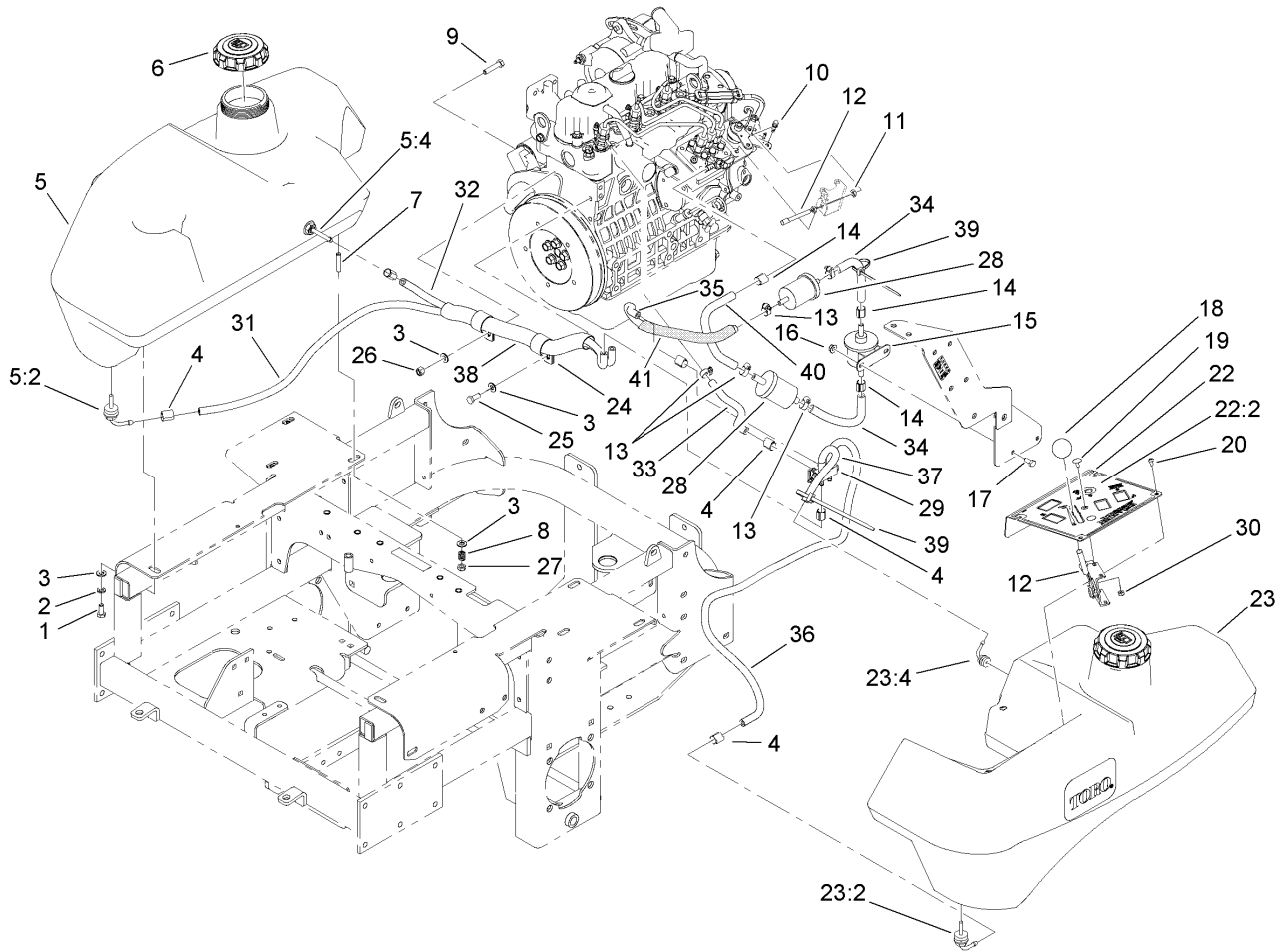

Throttle, Control Panel and Fuel Tank Assembly

Ref	Part No.	Qty.	Description
1	322-3	2	Screw-HH
2	1-805005	2	Washer-Lock
3	3256-23	11	Washer-Flat
4	1-643293	8	Clamp-Hose, Fuel
5	108-5361	1	RH Fuel Tank ASM
5:2	103-2605	1	Fitting-Fuel, Bulkhead
5:4	103-2615	1	Fitting-Fuel, Bulkhead
6	110-0897	2	Cap-Fuel, Diesel
7	1-633023	6	Stud
8	1-633349	6	Spring-Tank, Fuel
9	322-7	1	Screw-HH
10	108-5928	1	Swivel-Stop, Cable
11	3220-1	2	Nut-Jam
12	108-5927	1	Cable-Control, Throttle
13	2412-108	7	Clamp-Worm
14	1-643277	3	Clamp-Hose, Fuel
15	107-0122	1	Pump-Fuel, Electric
16	32128-33	2	Nut-HF
17	321-3	2	Screw-HH
18	1-603175	1	Knob-Ball
19	1-807513	2	Bolt-CARR
20	109-2661	4	Screw-PPH
22	112-2388	1	Control Panel ASM
22:2	112-2389	1	Decal-Panel, Control

Ref	Part No.	Qty.	Description
23	108-5362	1	LH Fuel Tank ASM
23:2	103-2605	1	Fitting-Fuel, Bulkhead
23:4	103-2615	1	Fitting-Fuel, Bulkhead
24	1-643312	2	Clip-Loom
25	33114-020	1	Screw-HH
26	3296-29	1	Nut-Lock, NI
27	3296-47	6	Nut-Lock, NI
28	98-7612	2	Filter-Fuel
29	1-643234	1	Valve-Fuel, Dual Flow
30	3296-2	2	Nut-Lock
31	108-5376	1	Hose-Fuel
32	109-0301	1	Hose-Fuel
33	110-1876	1	Hose-Fuel
34	112-2386	2	Hose-Fuel
35	109-0282	1	Hose-Fuel
36	109-0275	1	Hose-Fuel
37	109-0297	1	Hose-Fuel
38	108-5377	1	Sleeve-Fabric
39	1-303335	2	Tie-Plastic
40	110-4170	1	Hose-Fuel
41	114-1249	1	Cover-Fuel Line

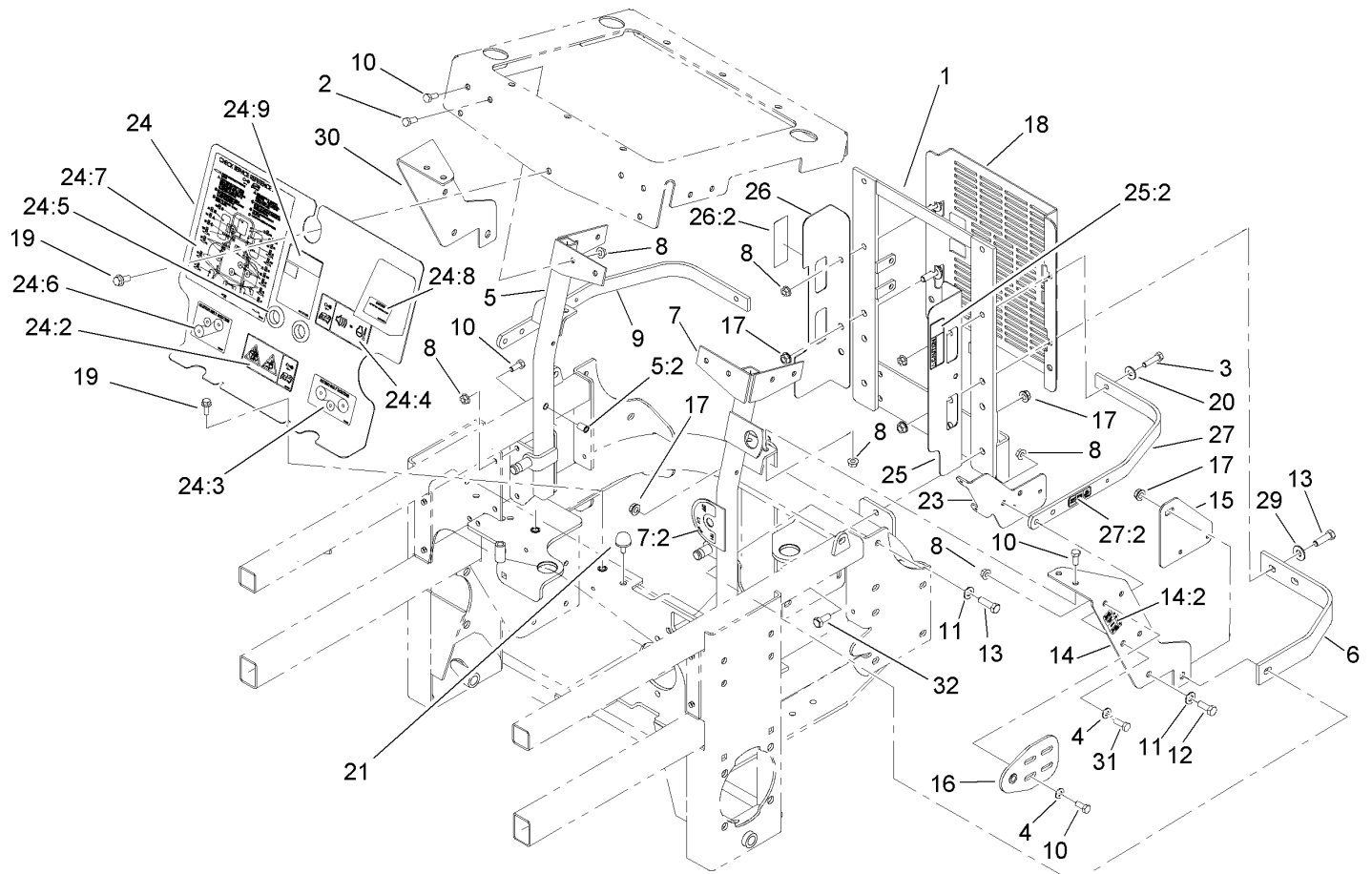

Engine Housing Assembly

Ref	Part No.	Qty.	Description
1	107-9934-03	1	Support-Radiator, Rear
2	322-5	2	Screw-HH
3	322-6	2	Screw-HH
4	3256-23	8	Washer-Flat
5	114-1170	1	RH Radiator Brace ASM
5:2	32148-11	1	Insert-Threaded
6	103-7623-03	2	Strap-Guard
7	110-3870	1	LH Radiator Brace ASM
7:2	107-2114	1	Decal-Valve, Fuel
8	32128-20	22	Nut-HF
9	1-633897-03	1	Rib-Top
10	322-3	14	Screw-HH
11	3256-24	4	Washer-Flat
12	323-6	2	Screw-HH
13	323-7	4	Screw-HH
14	112-8318	1	LH Support Bracket ASM
14:2	112-8319	1	Decal-Fuses
15	108-5349-03	1	Bracket-Pump, Fuel
16	108-5345-03	2	Hood Pivot Plate ASM
17	3290-357	8	Nut-HHF, Whiz
18	112-8302-03	1	Shield-Cooler
19	3234-33	3	Screw-HHF
20	3256-3	2	Washer-Flat
21	109-2365	2	Bumper-Rubber (W/Stud)

Ref	Part No.	Qty.	Description
23	107-8081-03	1	Bracket-Relay/Fuse
24	114-1829	1	Front Shield ASM W/Decals
24:2	110-3853	1	Decal-Danger, Rotating Devices
24:3	108-5955	1	Decal-Routing, Hydro Belt
24:4	110-3852	1	Decal-Buzzer, Warning
24:5	100-3815	2	Grommet-Rubber
24:6	108-5957	1	Decal-Routing, Clutch Belt
24:7	114-1826	1	Decal-Check Service
24:8	110-0806	1	Decal-Caution
24:9	104-2449	1	Decal-Coolant
25	110-0879	1	Guard-Fan, LH (Ce)
25:2	107-7719	1	Decal-Danger, Rotating Devices
26	110-0888	1	Guard-Fan, RH (Ce)
26:2	107-7719	1	Decal-Danger, Rotating Devices
27	110-0890	1	Strap-Top
27:2	110-0305	1	Decal-Relay
29	3256-4	2	Washer-Flat
30	108-5339-03	1	Bracket-Support, RH
31	322-4	4	Screw-HH
32	323-5	2	Screw-HH

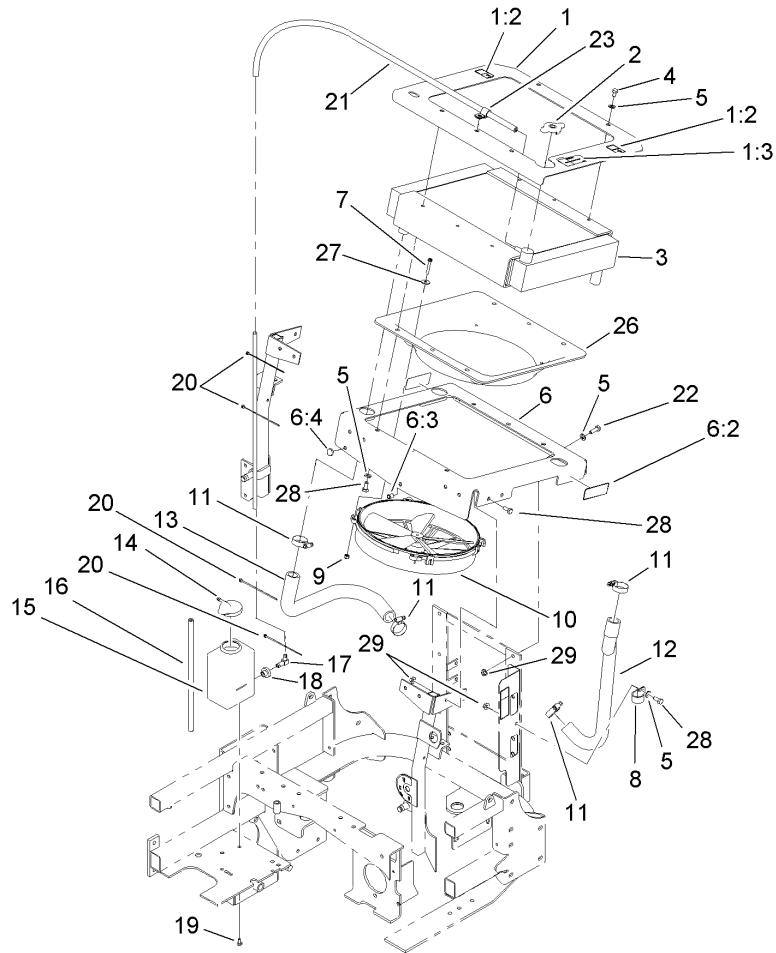

Cooling System Assembly

Ref	Part No.	Qty.	Description
1	110-3845	1	Top Radiator Plate ASM
1:2	93-8069	2	Decal-Surface, Hot
1:3	110-3842	1	Decal-Antifreeze
2	1-643161	1	Cap-Radiator
3	107-9932	1	Radiator
4	322-1	6	Screw-HH
5	3256-23	16	Washer-Flat
6	110-0880	1	Bottom Radiator Plate ASM (Ce)
6:2	107-7719	2	Decal-Danger, Rotating Devices
6:3	32148-6	1	Insert-Nut
6:4	1-513658	2	Bumper
7	1-803067	4	Screw
8	1-643312	1	Clip-Loom
9	1-804254	4	Nut
10	1-633831	1	Fan
11	1-633989	4	Clamp-Hose
12	108-5372	1	Hose-Radiator, Left
13	108-5904	1	Hose-Outlet, Engine
14	1-643164	1	Cap-Tank, Overflow
15	1-643163	1	Tank-Overflow
16	1-603954	1	Hose-Line, Fuel
17	1-643259	1	Fitting-Elbow
18	1-513645	1	Bushing-Valve, Fuel
19	321-2	2	Screw-HH

Ref	Part No.	Qty.	Description
20	1-303287	5	Tie-Plastic
21	103-1428	1	Hose-Overflow
22	322-5	3	Screw-HH
23	1-603727	1	Clip-Loom
26	108-5971	1	Shroud-Cooling, Engine
27	3256-67	4	Washer-Flat
28	322-3	11	Screw-HH
29	32128-20	4	Nut-HF

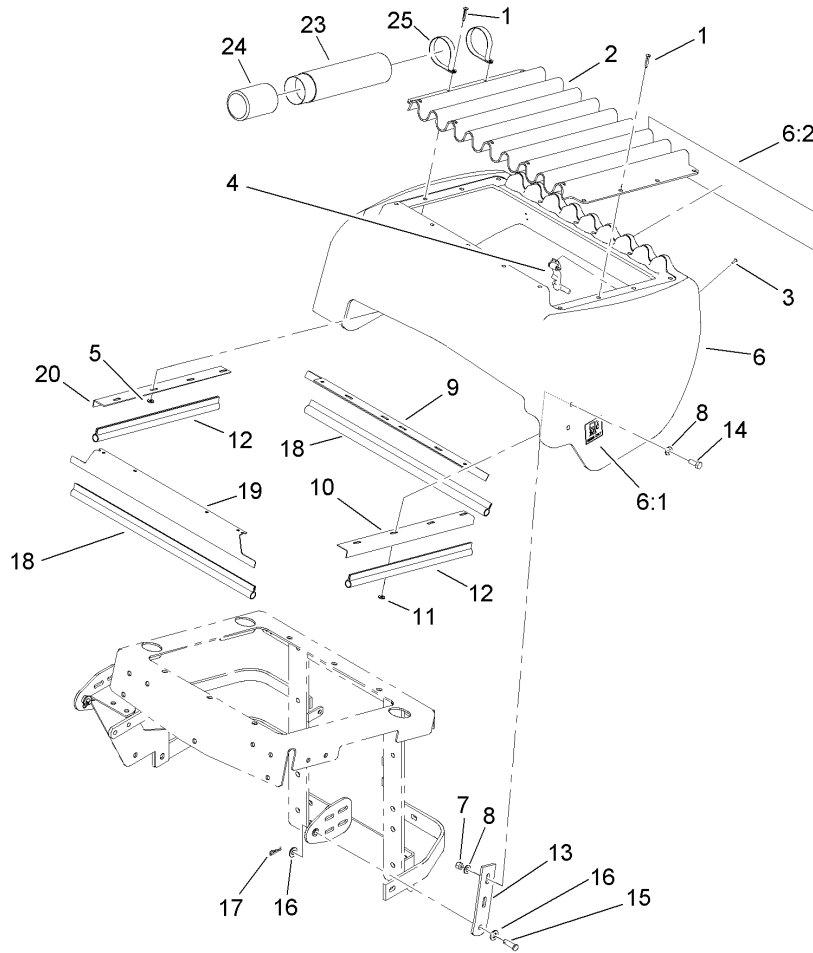

Hood Assembly

Ref	Part No.	Qty.	Description
1	1-803072	17	Rivet
2	1-633864-03	1	Screen-Radiator
3	923786	2	Rivet
4	1-643188	1	Latch-Rubber
5	1-303435	4	Washer-Spring
6	112-8304	1	Hood ASM
6:1	103-1636	2	Decal-Fuel
6:2	107-7674	1	Decal
7	3296-29	4	Nut-Lock, NI
8	3256-23	8	Washer-Flat
9	1-643108-03	1	Angle-Radiator, Bottom
10	1-643105-03	1	Angle-Radiator, LH
11	3256-14	12	Washer-Flat
12	1-643186	2	Seal-Trim
13	108-5337-03	2	Plate-Hinge, Hood
14	322-4	4	Screw-HH
15	1-808285	2	Pin-Clevis
16	3256-24	4	Washer-Flat
17	1-806003	2	Pin-Hair
18	1-643187	2	Seal-Trim
19	1-643107-03	1	Angle-Radiator, Top
20	1-643106-03	1	Angle-Radiator, RH
23	104-7050	1	Housing-Manual
24	104-7048	1	Cap-Housing

Ref	Part No.	Qty.	Description
25	2412-120	2	R-Clamp

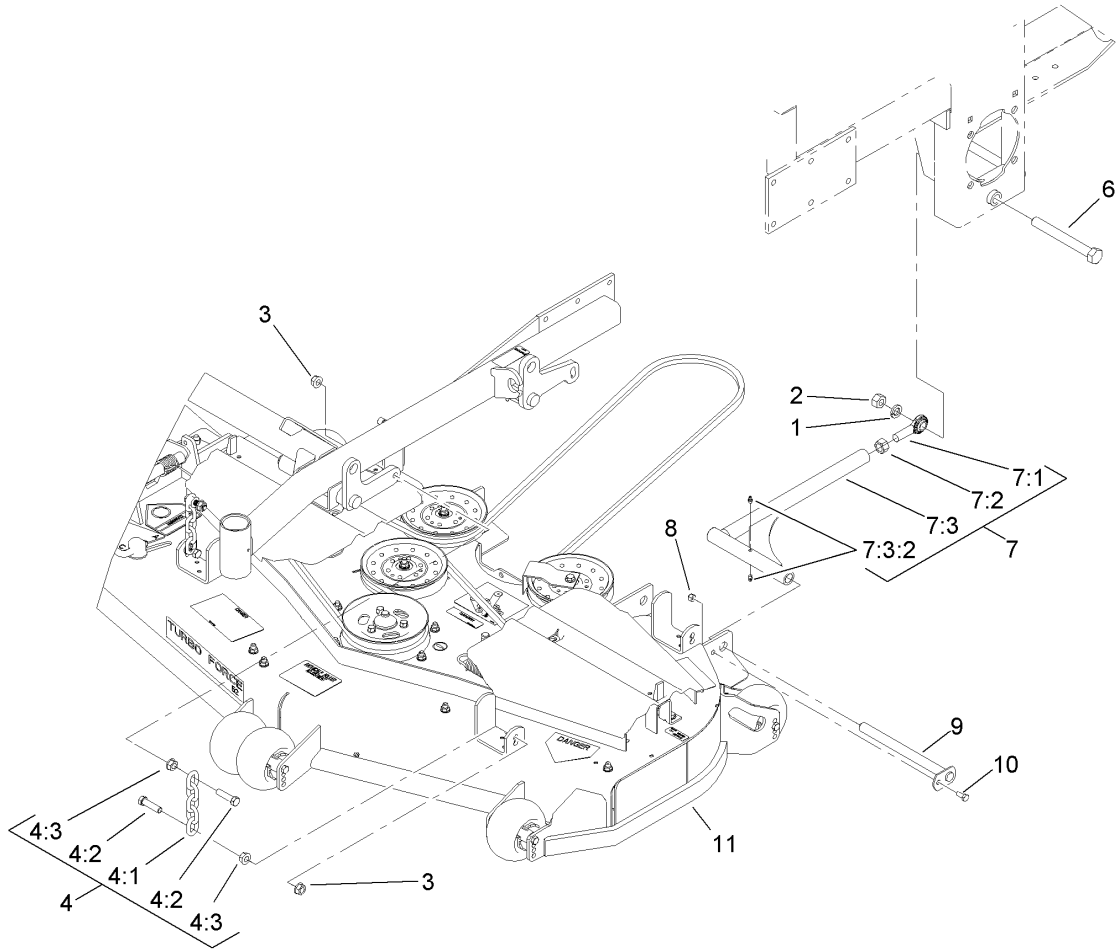

Deck Connection Assembly

Ref	Part No.	Qty.	Description
1	3253-8	2	Washer-Lock
2	3217-11	2	Nut-Hex
3	32128-37	8	Nut-HF
4	103-9792	4	Deck Chain ASM
4:1	1-633447	1	Chain-Lift, Deck
4:2	103-1898	2	Screw-HH
4:3	32128-37	2	Nut-HF
6	327-28	2	Screw-HH
7	108-5969	2	Strut ASM
7:1	1-633029	1	Balljoint-Spherical
7:2	3219-6	1	Nut-Hex
7:3		1	Strut-Deck
7:3:2	109-1380	2	Fitting-Grease
8	3296-29	2	Nut-Lock, NI
9	1-632199-01	2	Pin-Strut
10	322-3	2	Screw-HH
11		1	Deck ASM

Ref	Part No.	Qty.	Description

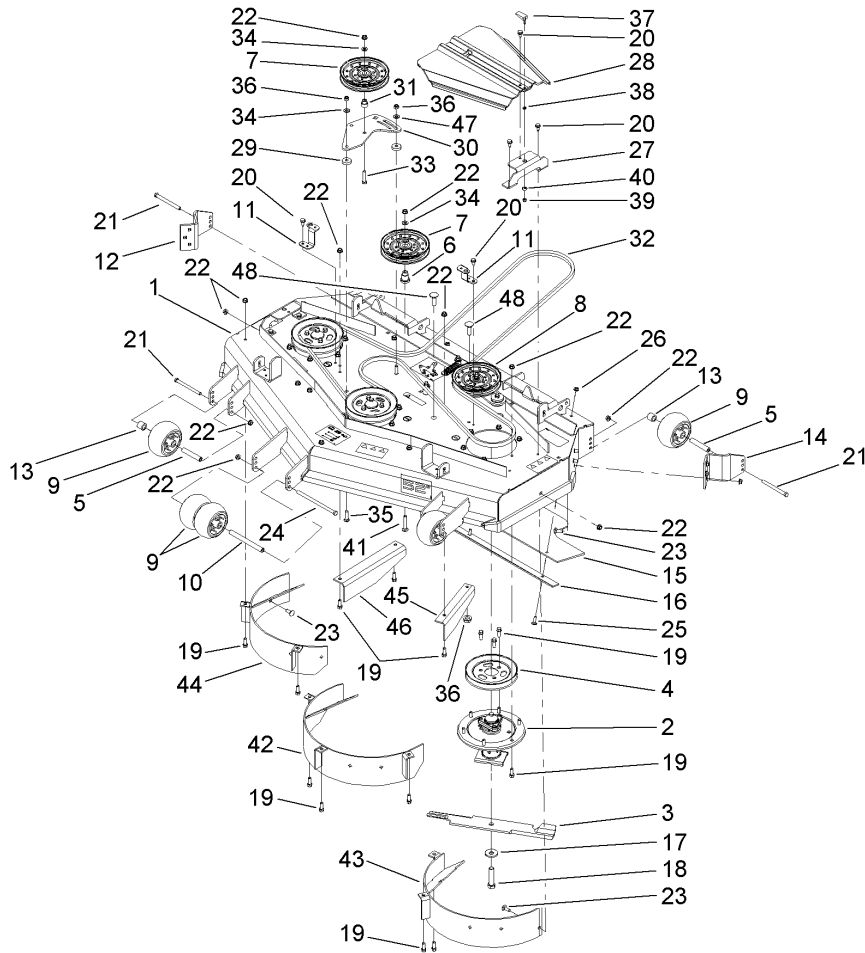

Deck Assembly

Ref	Part No.	Qty.	Description
1	112-3751	1	Deck Decal ASM
2	108-7713	3	Spindle ASM
3	105-7781-03	3	Blade-Hi Flow, 18 Inch
4	108-5979	3	Pulley-B Section
5	98-7912	4	Tube-Spanner
6	106-3214	1	Mount-Pulley
7	1-633109	2	Idler-Flat
8	114-1812	1	Spring Idler ASM
9	1-603299	6	Roller-Scalp, Anti
10	98-5967	1	Spacer-Wheel
11	108-2177-01	2	Bracket-Cover, Tall
12	112-3893-01	1	Mount-Anti Scalp, RH
13	98-7913	4	Tube-Spacer
14	112-3895-01	1	Mount-Anti Scalp, LH
15	112-3869	1	Deflector-Rubber
16	112-3868-01	1	Skid-Skirt
17	103-0865	3	Washer-Blade Bolt, Heavy
18	103-0862	3	Screw-Cap
19	92-1624	35	Screw
20	32144-70	8	Screw-HWHTF
21	323-23	4	Screw-HH
22	3290-357	43	Nut-HHF, Whiz
23	3231-2	8	Screw-CARR
24	323-28	1	Screw-HH

Ref	Part No.	Qty.	Description
25	3230-2	4	Bolt-CARR
26	32128-20	4	Nut-HF
27	114-1809-01	2	Bracket-Belt Cover
28	107-8536	2	Cover-Belt
29	105-7788	2	Spacer
30	107-8516-01	1	Plate-Idler
31	1-603496	1	Bushing-Idler
32	108-5951	1	Belt-V
33	323-9	1	Screw-HH
34	3256-24	2	Washer-Flat
35	3231-4	2	Screw-CARR
36	3296-39	4	Nut-Lock, NI
37	106-6777	2	Handle-Latch, Swell
38	99-3058	2	Washer
39	1-804254	2	Nut
40	106-6778	2	Bushing-Latch, Swell
41	3231-7	1	Screw-CARR
42	112-3871-01	1	Center Baffle ASM
43	112-3872-01	1	LH Baffle ASM
44	112-3873-01	1	RH Baffle ASM
45	112-3862-01	1	Baffle-Trailing
46	112-3863-01	1	Baffle-Trailing
47	98-5975	1	Washer-Belleville
48	3231-2	2	Screw-CARR

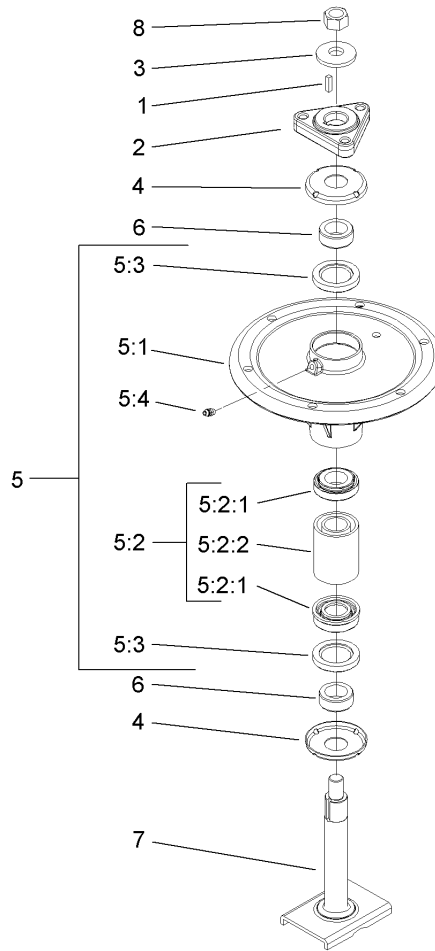

Spindle Assembly No. 108-7713

Ref	Part No.	Qty.	Description
1	10-8040	1	Key-Square
2	106-3277	1	Hub-Pulley
3	103-0865	1	Washer-Blade Bolt, Heavy
4	106-3204	2	Shield-Bearing
5		1	Spindle Bearing ASM
5:1	106-3211	1	Housing-Spindle
5:2	108-7711	1	Bearing ASM
5:2:1	108-7710	1	Bearing ASM
5:2:2	106-3206	1	Spacer (Matched Set)
5:3	253-133	2	Seal-Oil
5:4	302-5	1	Fitting-Grease
6	106-3218	2	Spacer-Seal
7	106-3233	1	Spindle Shaft ASM
8	3219-6	1	Nut-Hex

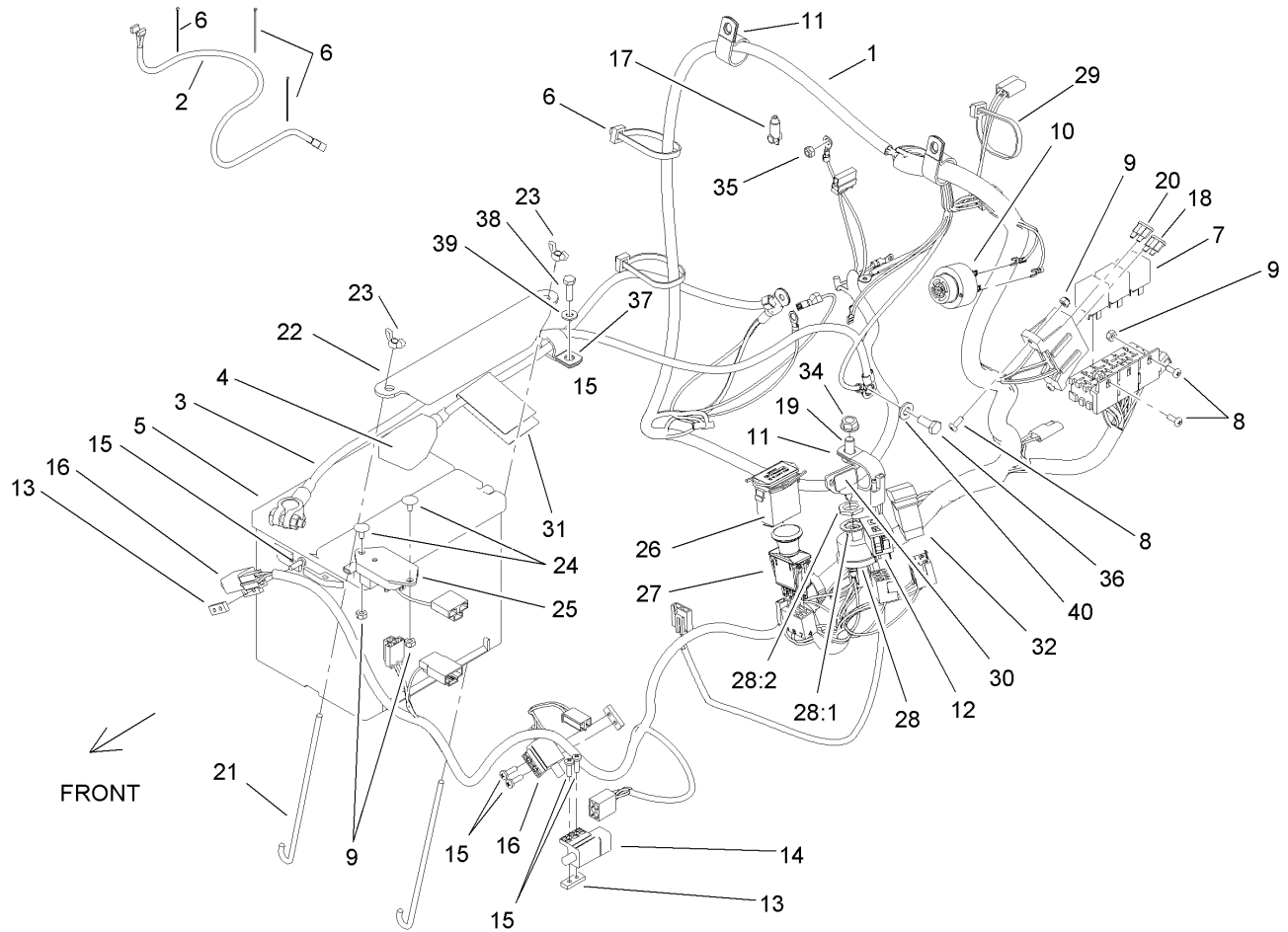

Electrical Assembly

Ref	Part No.	Qty.	Description
1	112-8315	1	Harness-Electrical, Main
2	103-1227	1	Harness-Wiring, Seat
3	110-0303	1	Cable-Battery, Negative
4	110-0304	1	Cable-Battery, Positive
5	106-5187	1	Battery
6	1-303335	7	Tie-Plastic
7	1-643275	3	Relay
8	1-803071	4	Screw
9	3296-2	6	Nut-Lock
10	103-0205	1	Alarm-Tone, Dual
11	1-643312	3	Clip-Loom
12	100-8071	1	Lamp-Warning
13	1-633181	3	Plate-Tapped
14	1-633111	1	Switch
15	3290-500	6	Screw-PPH
16	1-513051	2	Switch-Open, Normally
17	1-643178	1	Cap-Insulator, Red
18	103-1368	1	Fuse-40 Amp
19	323-4	1	Screw-HH
20	109103	1	Fuse-30 Amp
21	103-1312	2	Bolt-Holddown
22	103-1311-03	1	Holddown-Battery
23	1-543792	2	Wingnut
24	1-807513	2	Bolt-CARR

Ref	Part No.	Qty.	Description
25	103-5218	1	Module-Delay, Seat
26	1-513374	1	Meter-Hour
27	103-5221	1	Switch-PTO
28	104-2541	1	Switch-Key
28:1	218-461	1	Nut-HH
28:2	3254-5	1	Washer-Tooth
29	1-303287	1	Tie-Plastic
30	63-8360	2	Key-Ignition
31	107-9309	1	Decal-Instructions, Charging
32	110-0811	1	Switch-Rocker
34	3290-357	1	Nut-HHF, Whiz
35	33023-00	1	Nut-Lock
36	33114-016	1	Screw-HH
37	1-633396	2	Clip-Loom
38	321-5	2	Screw-HH
39	3256-22	2	Washer-Flat
40	3256-23	1	Washer-Flat

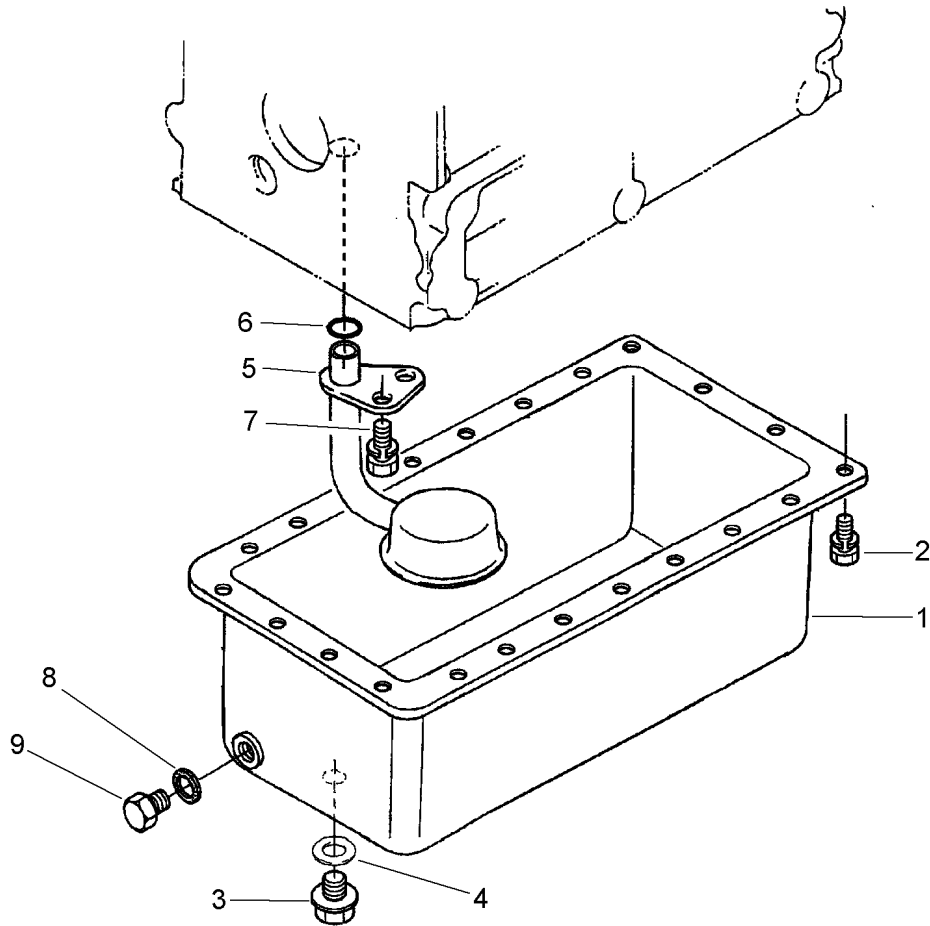

Oil Pan Assembly

Ref	Part No.	Qty.	Description
1	110-3703	1	Oil Pan ASM
2	98-9351	22	Bolt
3	98-7523	1	Plug-Drain
4	98-9399	1	Gasket
5	100-2001	1	Strainer-Oil, Pick-Up
6	100-2205	1	O-Ring
7	100-9195	1	Bolt
8	110-3704	1	Gasket
9	108-6572	1	Plug-Drain

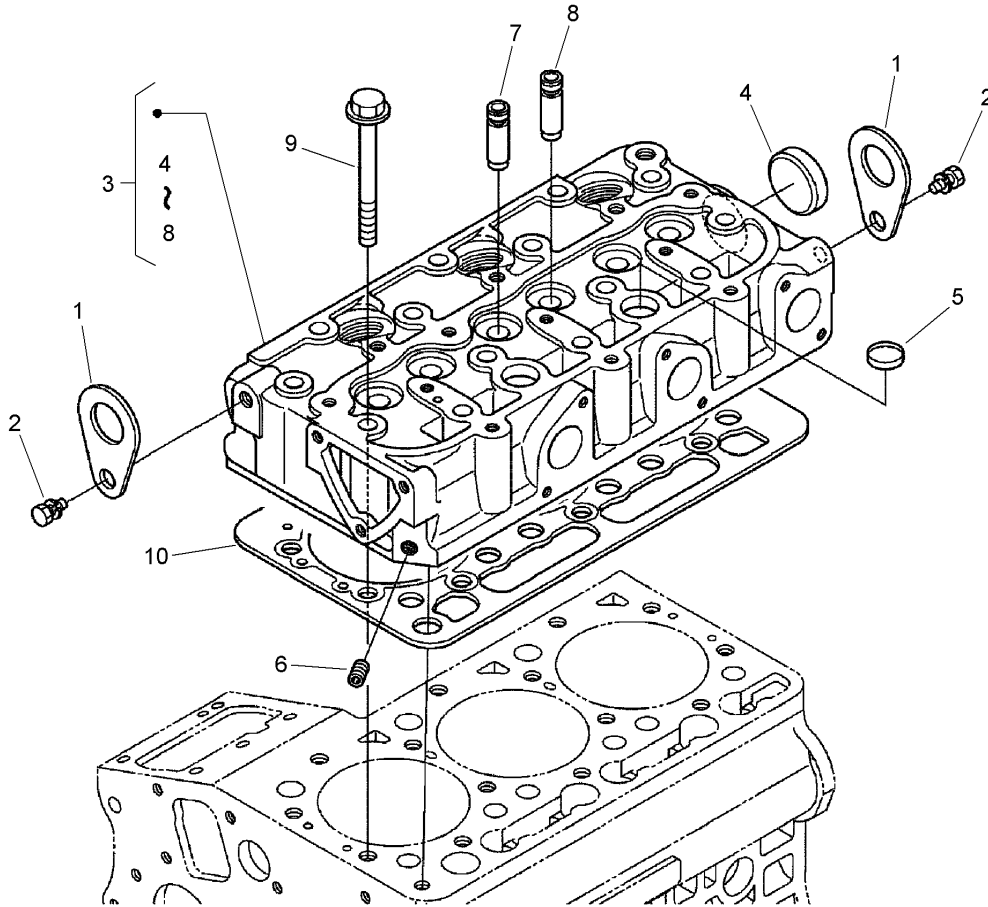

Cylinder Head Assembly

Ref	Part No.	Qty.	Description				
1	98-7531	2	Hook-Engine				
2	98-7526	2	Bolt				
3	110-3705	1	Head-Cylinder				
4	98-9395	1	Cap-Sealing				
5	98-9389	2	Cap-Sealing				
6	98-7540	1	Plug				
7	100-1882	3	Guide-Valve, Inlet				
8	100-1883	3	Guide-Valve, Exhaust				
9	100-1820	14	Bolt-Head, Cylinder				
10	110-3706	1	Gasket-Head, Cylinder				

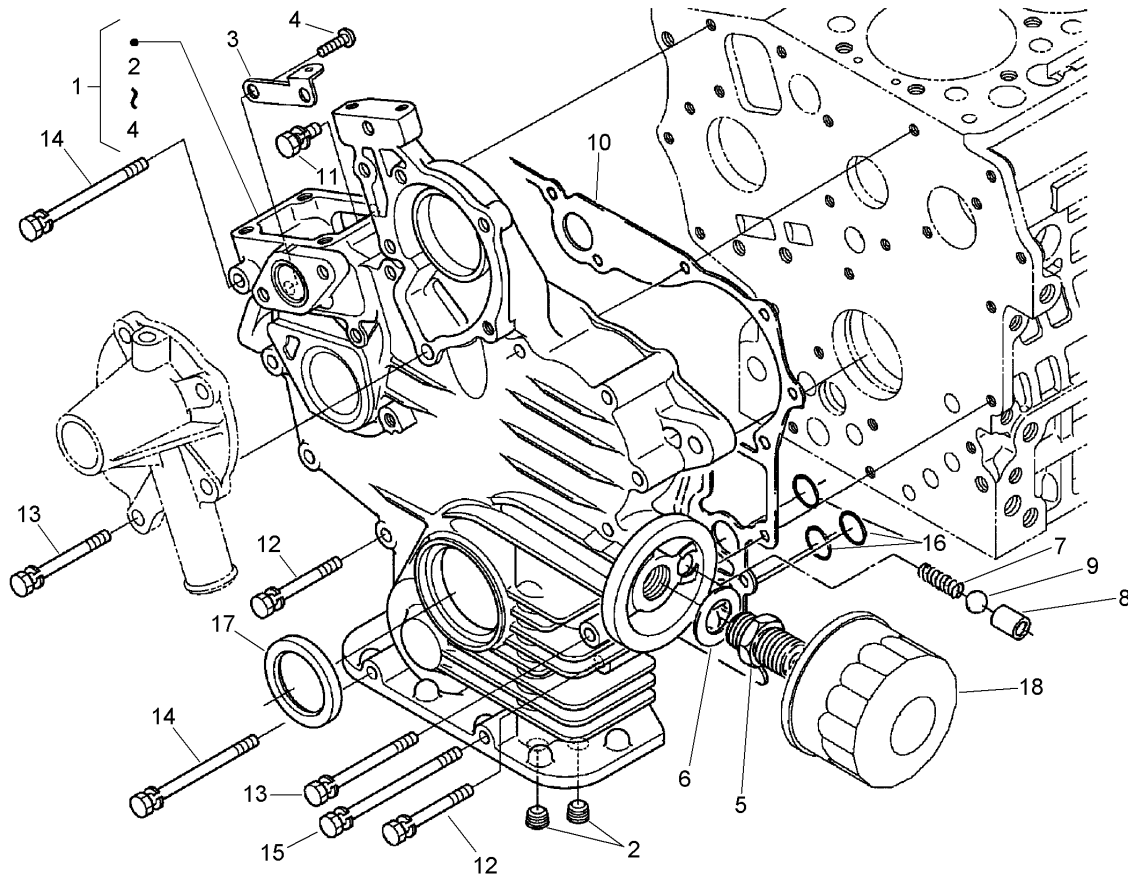

Gear Case and Oil Filter Cartridge Assembly

Ref	Part No.	Qty.	Description
1	110-3707	1	Case-Gear
2	98-7488	2	Plug
3	110-3708	1	Stay-Spring, Start
4	100-2040	2	Screw
5	98-9388	1	Joint-Pipe
6	100-1926	1	Washer-Plain
7	100-2004	1	Spring
8	100-1894	1	Seat-Valve
9	100-1792	1	Ball
10	110-3709	1	Gasket-Gearcase
11	98-7605	1	Bolt
12	98-9355	9	Bolt
13	100-1922	2	Bolt
14	98-9357	2	Bolt
15	110-3710	1	Bolt
16	100-1785	3	O-Ring
17	100-1971	1	Seal-Oil
18	100-1892	1	Cartridge-Filter, Oil

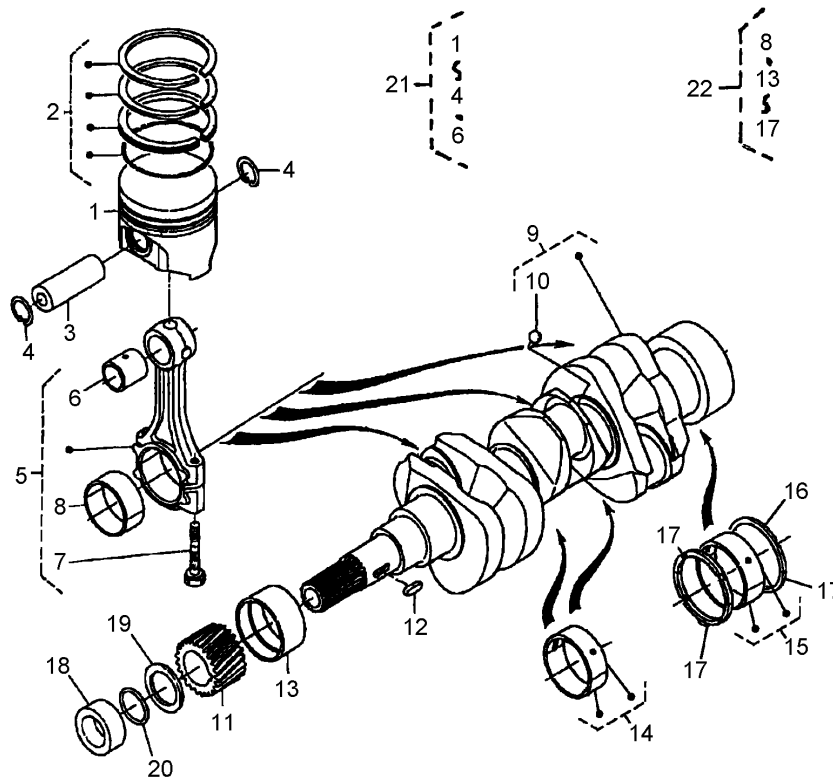

Piston and Crankshaft Assembly

Ref	Part No.	Qty.	Description
1	112-8399	3	Piston +.25Mm
1	112-8398	3	Piston STD
2	110-3732	3	Piston Ring ASM (STD)
2	110-3733	3	Piston Ring ASM (+.25Mm)
3	110-3734	3	Pin-Piston
4	100-1835	6	Clip-Pin, Piston
5	110-3735	3	Connecting Rod ASM
6	110-3736	3	Bushing-Pin, Piston
7	100-1999	6	Bolt-Rod, Connecting
8	100-2000	3	Metal-Crankpin (STD)
8	100-1943	3	Crankpin-Metal (-0.4Mm)
8	100-1942	3	Crankpin-Metal (-0.2Mm)
9	110-3737	1	Crankshaft
10	100-1791	3	Ball
11	100-1891	1	Gear-Crankshaft
12	100-1752	1	Key-Feather
13	110-3738	1	Metal-Crankshaft (STD)
13	110-3739	1	Metal-Crankshaft (-.20Mm)
13	110-3740	1	Metal-Crankshaft (-.40Mm)
14	110-3743	2	Crankshaft Metal ASM (-.40Mm)
14	110-3742	2	Crankshaft Metal ASM (-.20Mm)
14	110-3741	2	Crankshaft Metal ASM (STD)
15	110-3746	1	Crankshaft Metal ASM (-.40Mm)
15	110-3745	1	Crankshaft Metal ASM (-.20Mm)

Ref	Part No.	Qty.	Description
15	110-3744	1	Crankshaft Metal ASM (STD)
16	100-1839	2	Metal-Side (+0.4Mm)
16	100-1838	2	Metal-Side (+0.2Mm)
16	100-1836	2	Metal-Side (STD)
17	100-1841	2	Metal-Side (+0.4Mm)
17	100-1840	2	Metal-Side (+0.2Mm)
17	100-1837	2	Metal-Side (STD)
18	100-1890	1	Collar-Crankshaft
19	100-1974	1	Slinger-Oil
20	100-2209	1	O-Ring
21	110-3747	3	Piston Kit (STD)
21	110-3748	3	Piston Kit
22	110-3751	1	Engine Metal Kit
22	110-3750	1	Engine Metal Kit
22	110-3749	1	Engine Metal Kit

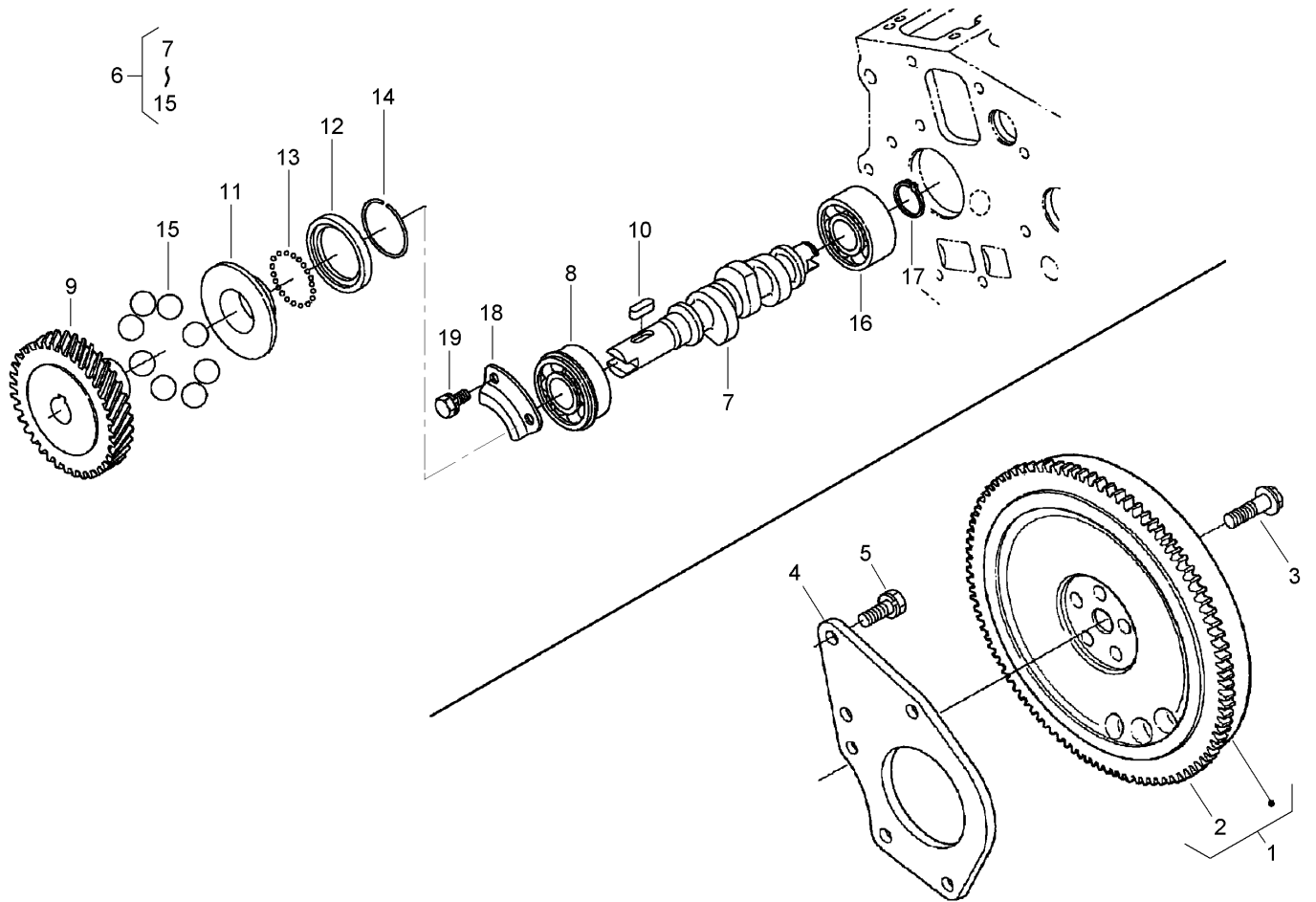

Flywheel, Fuel Camshaft and Governor Shaft Assembly

Ref	Part No.	Qty.	Description
1	110-3752	1	Flywheel
2	100-2156	1	Gear-Ring
3	100-1930	5	Bolt-Flywheel
4	110-3753	1	Plate-End, Rear
5	110-3754	3	Bolt
6	110-3755	1	Fuel Camshaft ASM
7	110-3756	1	Camshaft-Fuel
8	100-1795	1	Bearing-Ball
9	100-2006	1	Gear-Pump, Injection
10	100-1752	1	Key-Feather
11	100-1903	1	Sleeve-Governor
12	100-1904	1	Case-Ball, Governor
13	100-1790	32	Ball
14	100-1843	1	Clip-Sleeve, Governor
15	100-1793	8	Ball
16	110-3757	1	Bearing-Ball
17	100-1784	1	Clip-External
18	100-1888	1	Stopper-Fuel, Camshaft
19	98-9350	2	Bolt

Ref	Part No.	Qty.	Description

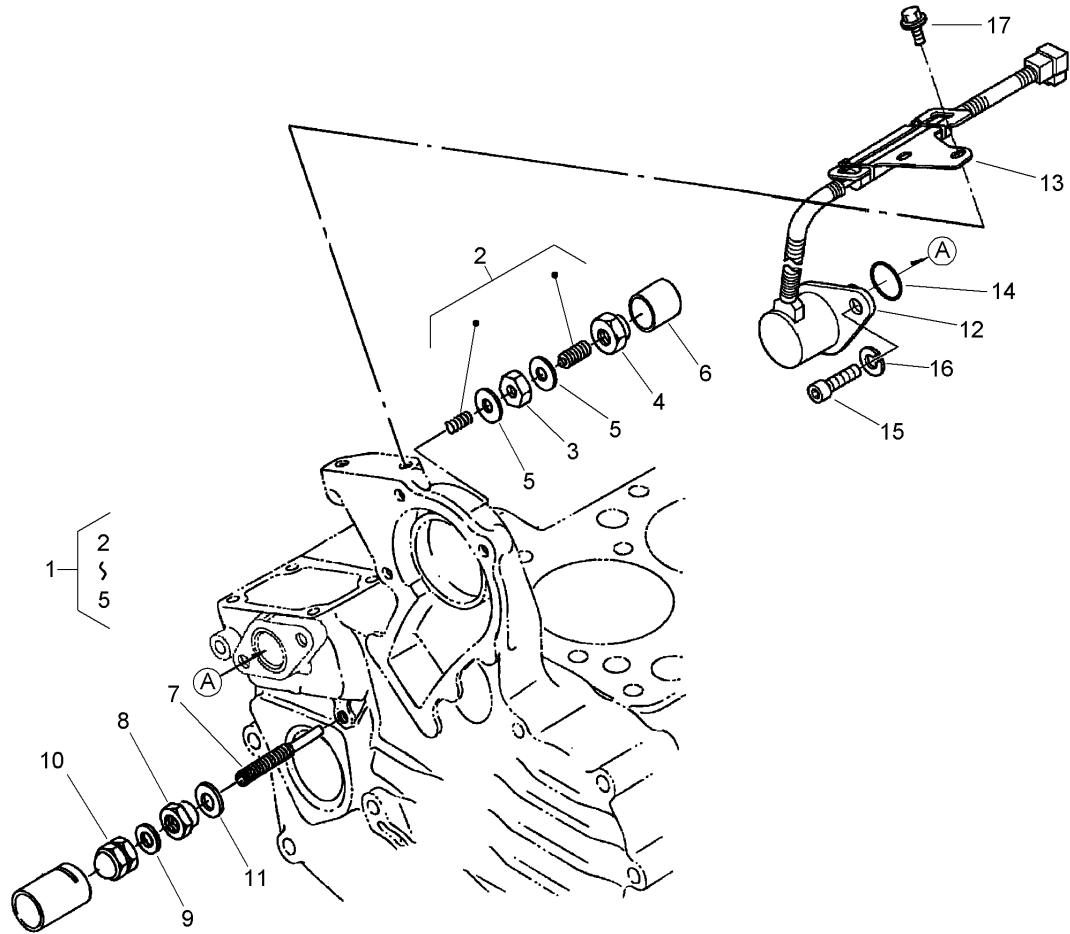

Idle Apparatus and Stop Solenoid Assembly

Ref	Part No.	Qty.	Description
1	100-1898	1	Idle Apparatus ASM
2	100-1899	1	Adjusting Bolt ASM
3	100-1846	1	Nut
4	100-1901	1	Nut-Cap
5	98-7428	2	Gasket
6	100-1902	1	Cap
7	110-3758	1	Bolt-Adjusting
8	100-2175	1	Nut-Lock
9	98-7654	1	Gasket
10	98-9441	1	Nut-Cap
11	107-9081	1	Gasket
12	110-3760	1	Solenoid-Stop
13	110-3761	1	Stay-Commander, Coil
14	110-3762	1	O-Ring
15	110-3763	2	Bolt-HSH
16	98-7515	2	Washer-Spring
17	100-1774	2	Bolt-Flange

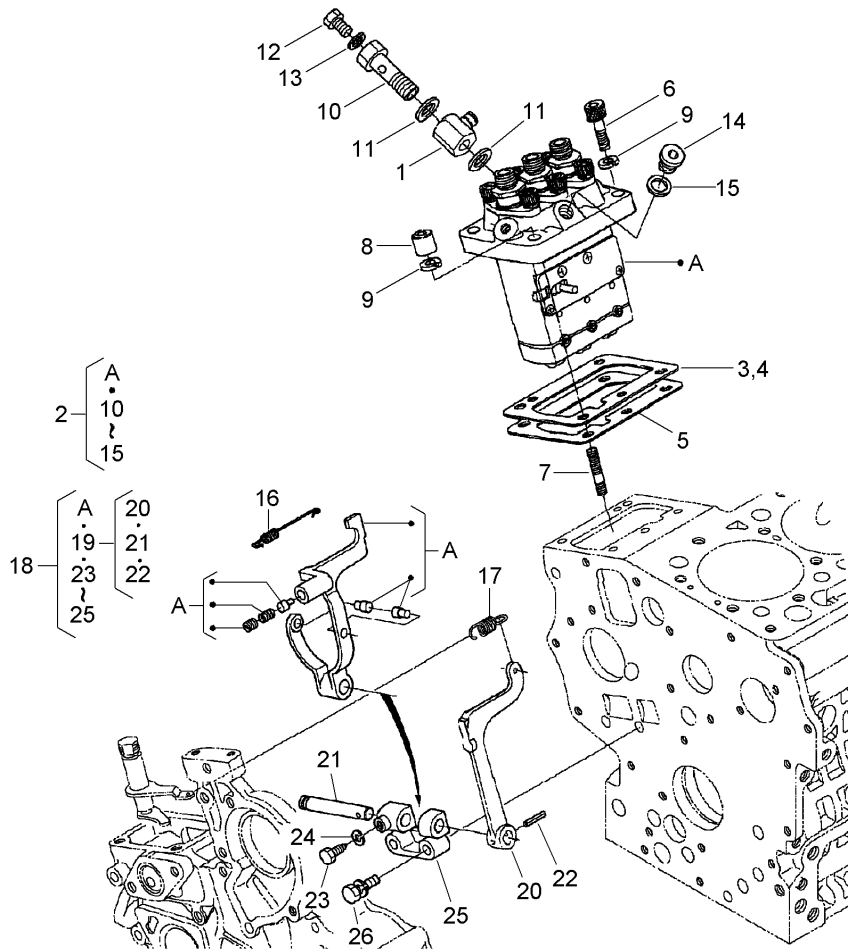

Injection Pump and Governor Assembly

Ref	Part No.	Qty.	Description
1	110-3764	1	Joint
2	110-3765	1	Injection Pump ASM
3	100-1951	1	Shim-Pump, Injection
4	100-1952	1	Shim-Pump, Injection
5	98-9458	1	Shim-Injection (0.30Mm)
6	98-9361	2	Bolt-HSH
7	98-9438	2	Stud
8	98-9440	2	Nut-Cap
9	98-7515	4	Washer-Spring
10	100-1896	1	Screw-Hollow
11	98-9445	2	Gasket
12	98-9430	1	Screw
13	98-9446	1	Gasket
14	98-9466	1	Plug
15	98-9451	1	Gasket
16	110-3766	1	Spring-Start
17	110-3767	1	Spring-Governor
18	110-3768	1	Fork Lever ASM
19	100-1905	1	Fork Lever ASM
20	100-1907	1	Lever-Fork
21	100-1908	1	Shaft-Lever, Fork
22	100-1751	1	Pin-Spring
23	100-1845	1	Bolt
24	100-1783	1	Washer-Spring

Ref	Part No.	Qty.	Description
25	100-1909	1	Holder-Lever, Fork
26	100-1763	2	Bolt

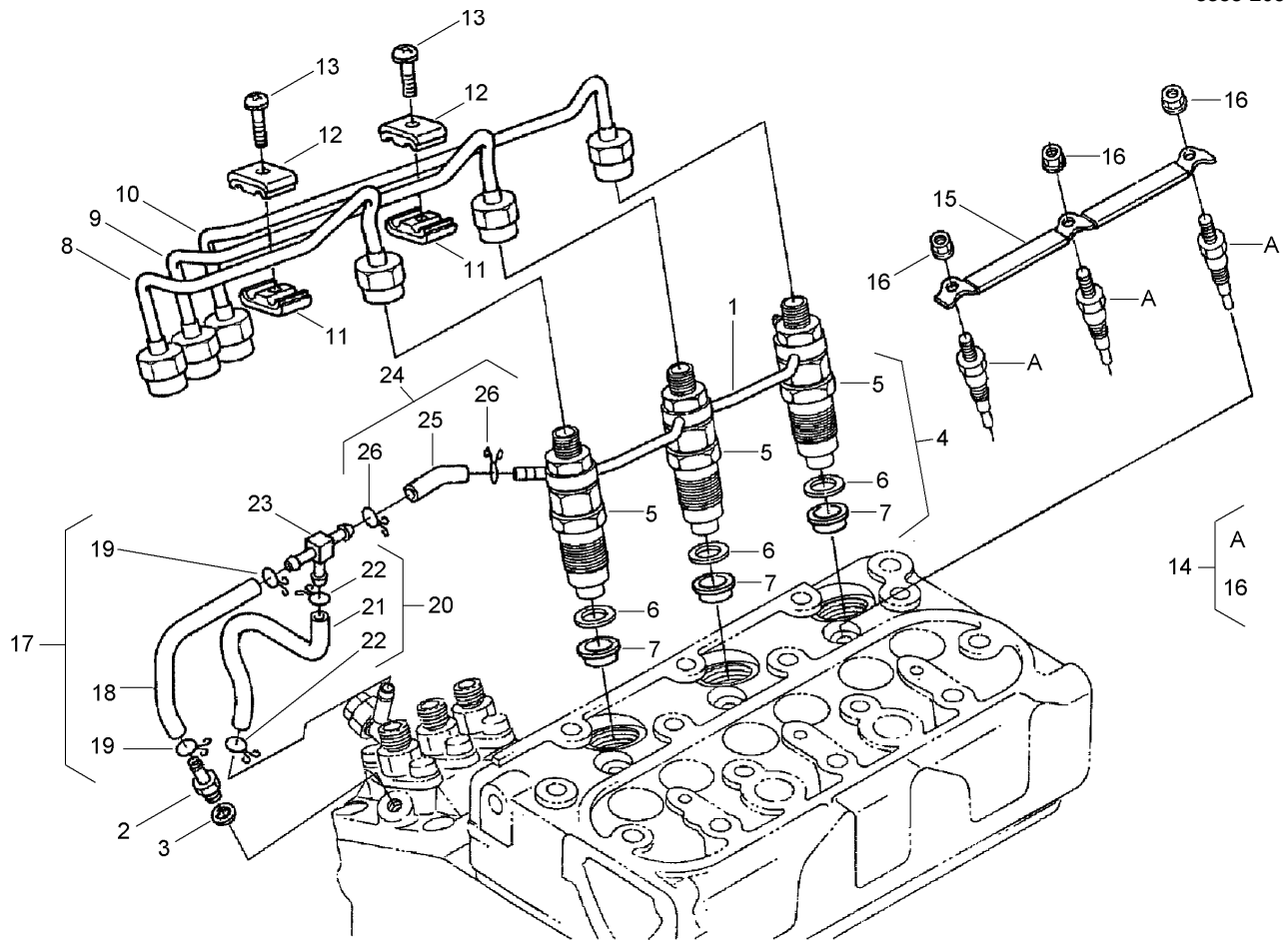

Nozzle Holder and Glow Plug Assembly

Ref	Part No.	Qty.	Description
1	110-3780	1	Over Flow Pipe ASM
2	98-9431	1	Screw-Bleeder
3	98-7654	1	Gasket
4	100-1982	3	Nozzle Holder Kit
5	100-1760	3	Nozzle Holder ASM
6	98-7676	3	Gasket
7	98-7677	3	Seal
8	110-3781	1	Pipe-Injection
9	110-3782	1	Pipe-Injection
10	110-3783	1	Pipe-Injection
11	98-7682	2	Clamp-Pipe
12	98-7683	2	Clamp-Pipe
13	98-7684	2	Screw (W/Washer)
14	98-7685	3	Plug-Glow
15	110-3784	1	Cord-Plug, Glow
16	99-8377	3	Nut-Flange
17	110-3785	1	Fuel Tube ASM
18	110-3786	1	Tube-Fuel
19	98-7671	4	Clip-Pipe
20	110-3787	1	Fuel Tube ASM
21	110-3788	1	Tube-Fuel
22	98-7671	2	Clip-Pipe
23	110-3789	1	Joint-T Pipe
24	110-3790	1	Fuel Tube ASM

Ref	Part No.	Qty.	Description
25	110-3791	1	Tube-Fuel
26	98-9545	2	Band-Pipe

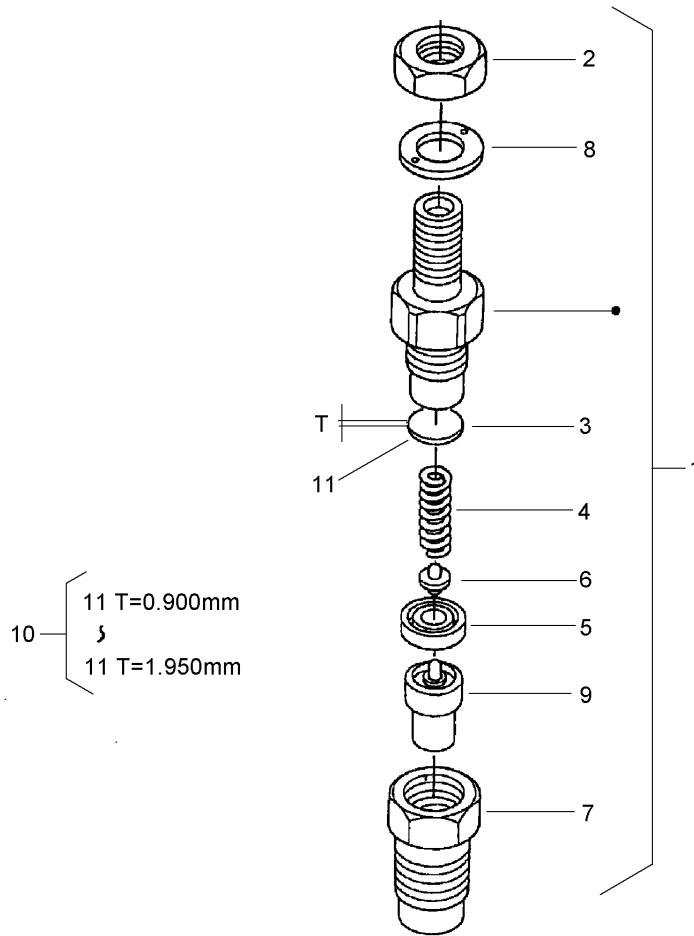

Nozzle Holder Assembly

Ref	Part No.	Qty.	Description
1	100-1760	3	Nozzle Holder ASM
2	98-7613	3	Nut
3	98-7642	3	Washer-Adjusting
4	98-7647	3	Spring-Nozzle
5	98-7665	3	Spacer-Distance
6	98-7666	3	Rod-Push
7	98-7667	3	Nut-Nozzle
8	98-7668	3	Washer
9	100-2009	3	Piece-Nozzle
10	98-9448	3	Adjusting Washer ASM
11	98-7642	3	Washer-Adjusting
11	98-7841	3	Washer-Adjusting
11	98-7842	3	Washer-Adjusting
11	98-7843	3	Washer-Adjusting
11	98-7844	3	Washer-Adjusting
11	98-7845	3	Washer-Adjusting
11	98-7846	3	Washer-Adjusting
11	98-7847	3	Washer-Adjusting
11	98-7848	3	Washer-Adjusting
11	98-7849	3	Washer-Adjusting
11	98-7850	3	Washer-Adjusting
11	98-7851	3	Washer-Adjusting
11	98-7852	3	Washer-Adjusting
11	98-7853	3	Washer-Adjusting

Ref	Part No.	Qty.	Description
11	98-7854	3	Washer-Adjusting
11	98-7855	3	Washer-Adjusting
11	98-7856	3	Washer-Adjusting
11	98-7857	3	Washer-Adjusting
11	98-7858	3	Washer-Adjusting
11	98-7859	3	Washer-Adjusting
11	98-7860	3	Washer-Adjusting
11	98-7861	3	Washer-Adjusting
11	98-7862	3	Washer-Adjusting
11	98-7863	3	Washer-Adjusting
11	98-7864	3	Washer-Adjusting
11	98-7865	3	Washer-Adjusting
11	98-7866	3	Washer-Adjusting
11	98-7867	3	Washer-Adjusting
11	98-7868	3	Washer-Adjusting
11	98-7869	3	Washer-Adjusting
11	98-7870	3	Washer-Adjusting
11	98-7871	3	Washer-Adjusting
11	98-7872	3	Washer-Adjusting
11	98-7873	3	Washer-Adjusting
11	98-7874	3	Washer-Adjusting
11	98-7875	3	Washer-Adjusting
11	98-7876	3	Washer-Adjusting
11	98-7877	3	Washer-Adjusting

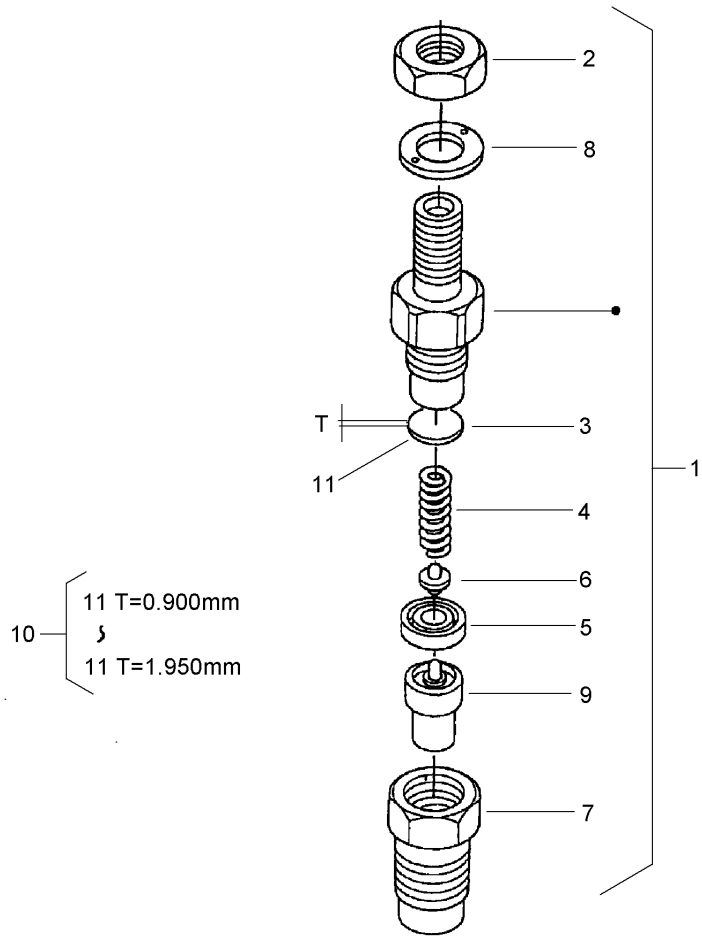

Nozzle Holder Assembly (continued)

Ref	Part No.	Qty.	Description
11	98-7878	3	Washer-Adjusting
11	98-7879	3	Washer-Adjusting
11	98-7880	3	Washer-Adjusting
11	98-7881	3	Washer-Adjusting
11	98-7882	3	Washer-Adjusting

--	--	--	--

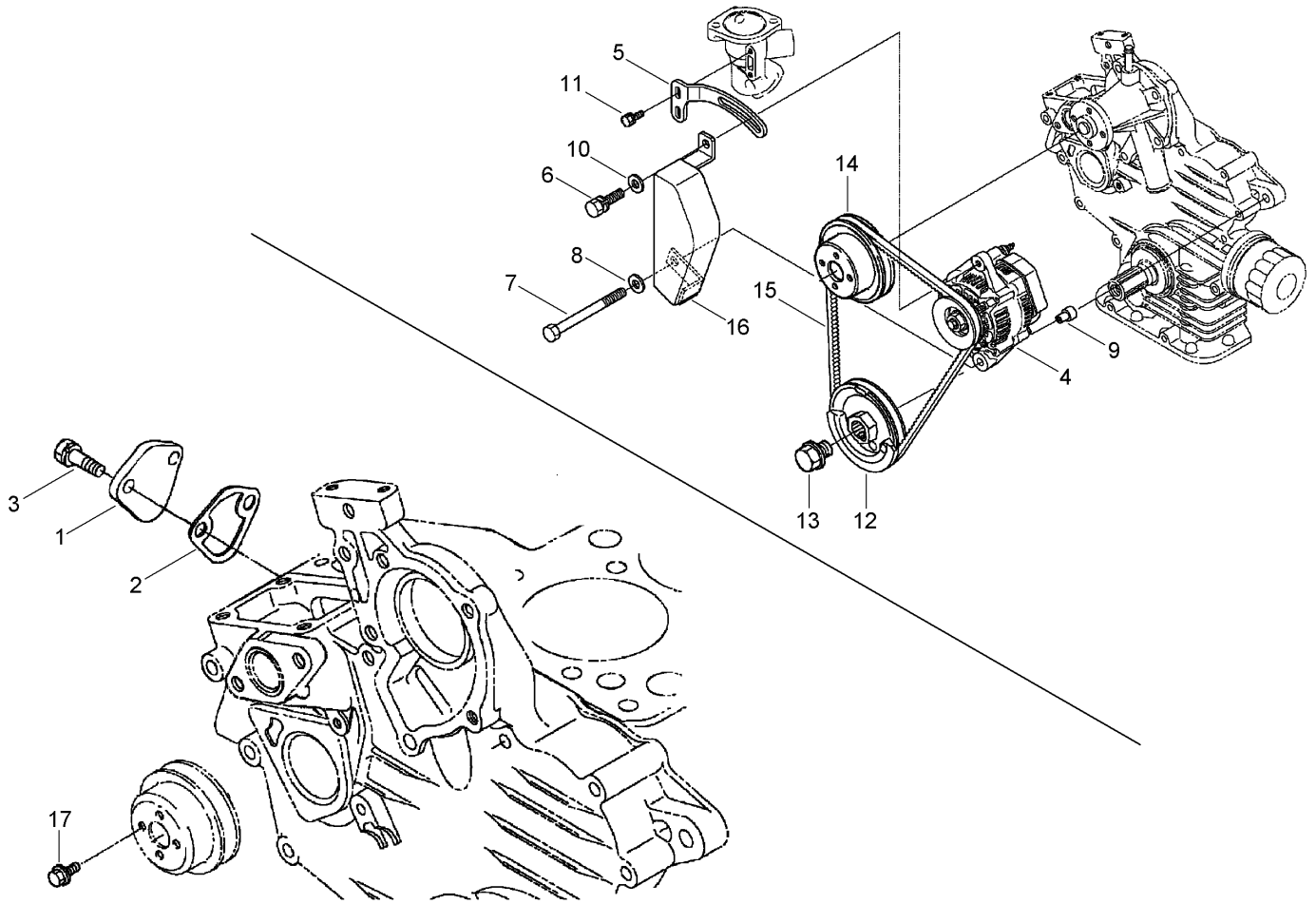

Alternator, Pulley and Fuel Pump Cover Assembly

Ref	Part No.	Qty.	Description
1	99-3514	1	Cover
2	100-1961	1	Gasket-Pump, Fuel
3	98-7692	2	Bolt
4	98-9474	1	Alternator ASM
5	110-3792	1	Stay-Alternator
6	98-7697	1	Bolt
7	110-3793	1	Bolt
8	98-7660	1	Washer-Plain
9	110-3794	1	Collar
10	100-9233	1	Washer-Plain
11	98-7692	2	Bolt
12	110-3795	1	Pulley-Drive, Fan
13	100-1978	1	Bolt
14	100-1921	1	Pulley-Fan
15	110-3796	1	V Belt
16	110-3797	1	Cover
17	99-8363	4	Bolt-Flange

--	--	--	--

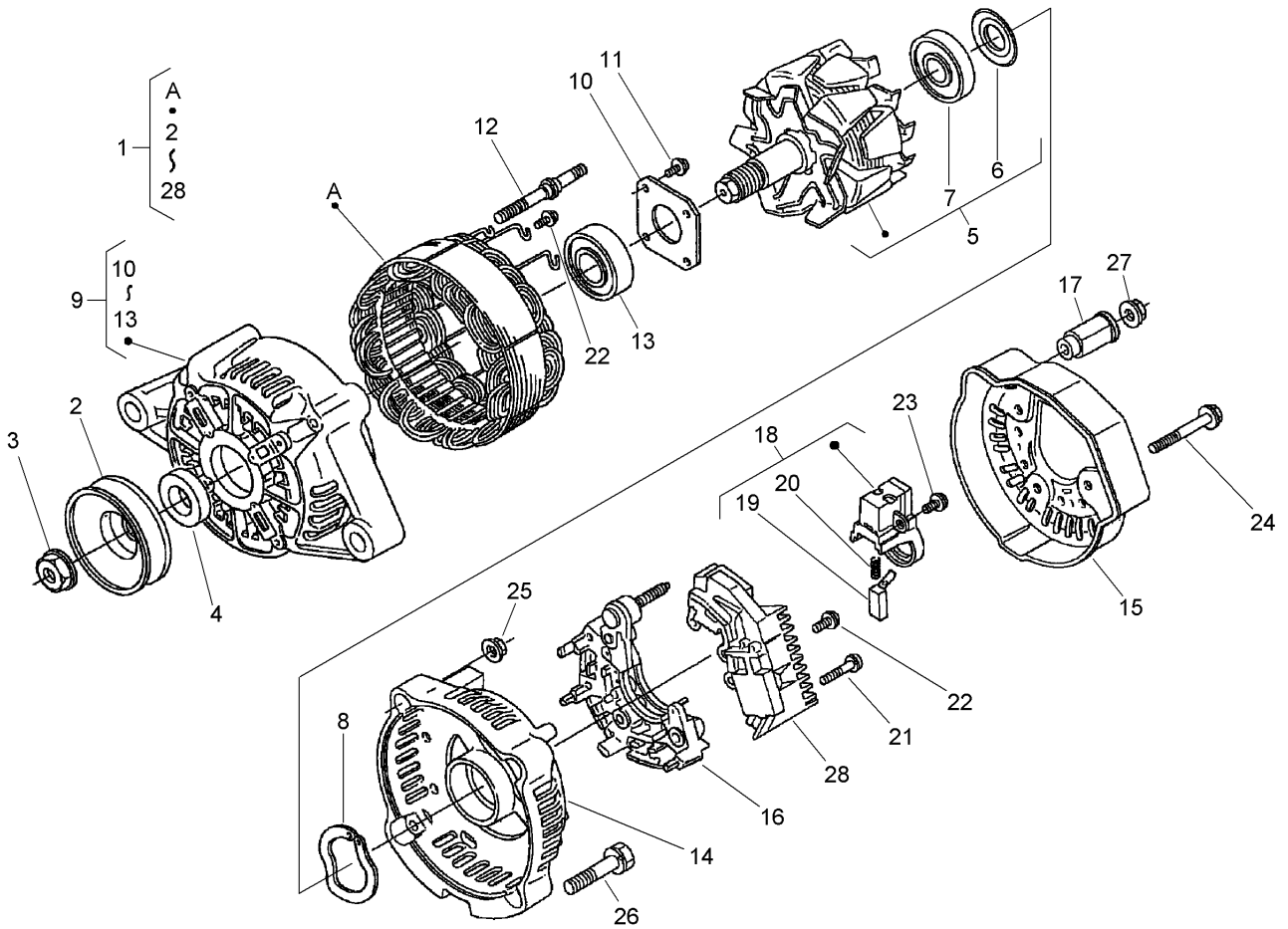

Alternator Assembly

Ref	Part No.	Qty.	Description
1	98-9474	1	Alternator ASM
2	98-9453	1	Pulley-Dynamo
3	98-7708	1	Nut
4	98-7709	1	Collar
5	107-0136	1	Rotor
6	98-7711	1	Cover-Bearing
7	107-0138	1	Bearing-Ball
8	98-7713	1	Washer-Thrust
9	107-0139	1	Drive End Frame ASM
10	98-7715	1	Plate-Retainer
11	98-7716	4	Screw-Head, Round
12	98-7717	2	Bolt-Through
13	107-0137	1	Bearing-Ball
14	107-9087	1	Frame-End
15	107-0140	1	Cover-End
16	98-7721	1	Rectifier ASM
17	98-7722	1	Bushing-Insulation
18	107-0141	1	Holder-Brush
19	98-7724	2	Brush
20	98-7725	2	Spring-Brush
21	98-7726	2	Screw-Head, Round
22	98-7727	6	Screw-Head, Round
23	98-7728	1	Screw-Head, Round
24	98-7729	3	Bolt

Ref	Part No.	Qty.	Description
25	98-7730	2	Nut
26	98-7731	2	Bolt
27	98-7732	1	Nut
28	110-3799	1	Regulator ASM

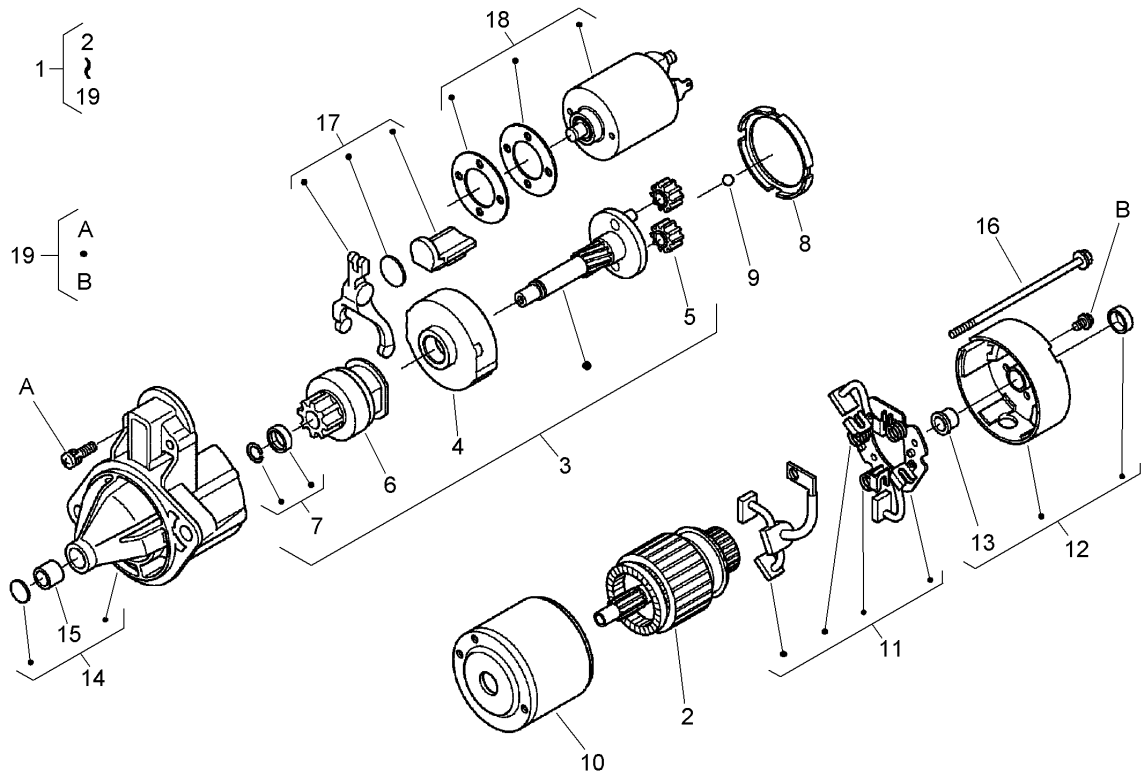

Starter Assembly

Ref	Part No.	Qty.	Description				
1	110-3800	1	Starter ASM				
2	110-3801	1	Armature				
3	110-3802	1	Shaft ASM				
4	110-3803	1	Gear-Internal				
5	110-3804	3	Gear-Planetary				
6	110-3805	1	Clutch-Running, Over				
7	110-3806	1	Stopper				
8	110-3807	1	Gasket				
9	110-3808	1	Ball				
10	110-3809	1	Yoke				
11	110-3810	1	Brush Holder ASM				
12	110-3811	1	Rear Bracket ASM				
13	110-3812	1	Bush				
14	110-3813	1	Front Bracket ASM				
15	110-3814	1	Bush				
16	110-3815	2	Bolt				
17	110-3816	1	Lever-Fork				
18	110-3817	1	Switch-Magnetic				
19	110-3818	1	Screw-Head, Pan				

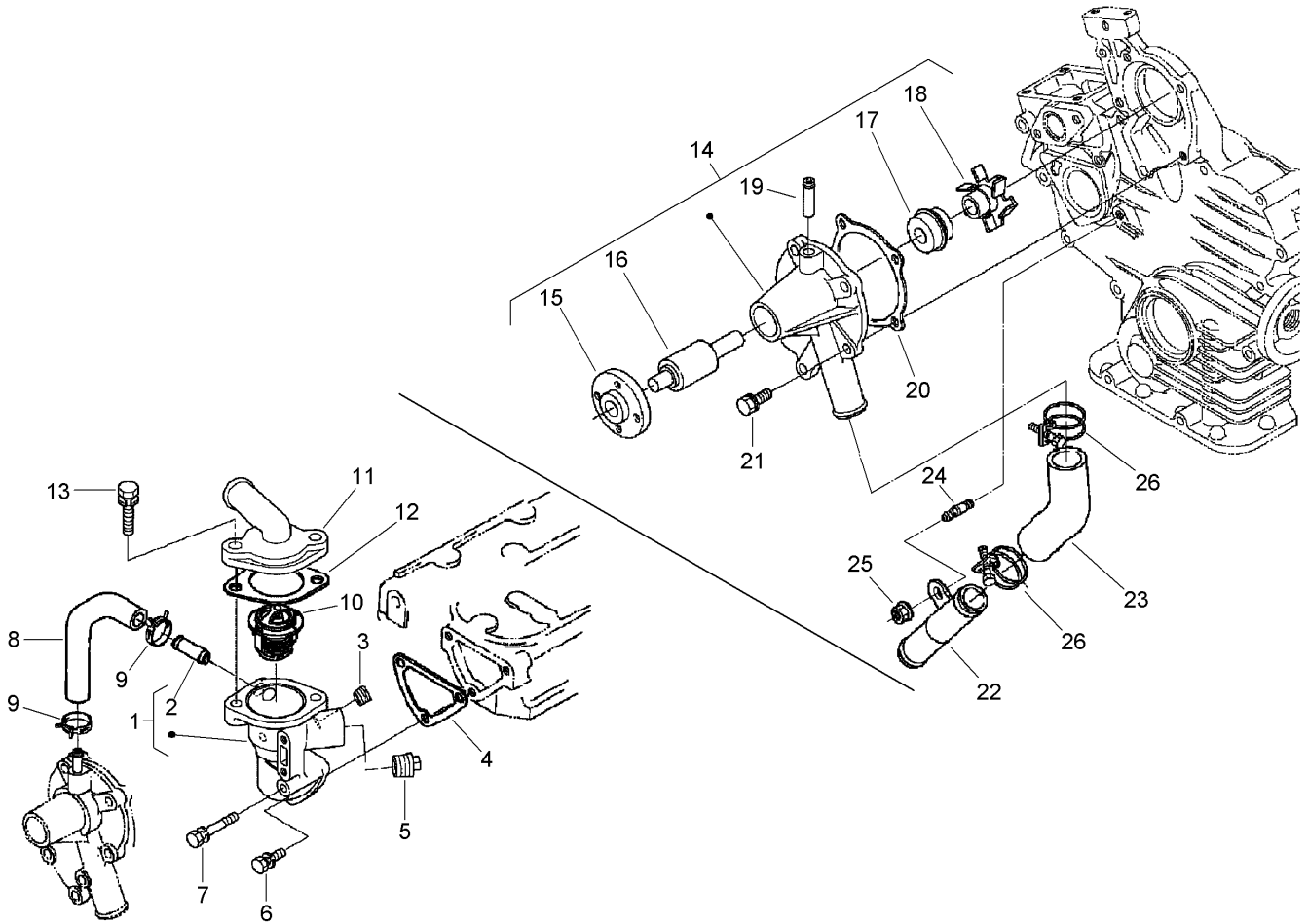

Water Flange, Pump, Pipe and Thermostat Assembly

Ref	Part No.	Qty.	Description
1	110-3819	1	Flange-Water
2	98-9580	1	Pipe-Return, Water
3	98-9444	1	Plug
4	110-3820	1	Gasket-Flange, Water
5	110-3821	1	Plug
6	98-7692	2	Bolt
7	98-9355	1	Bolt
8	110-3822	1	Pipe-Return, Water
9	98-9579	2	Band-Pipe
10	98-7778	1	Thermostat ASM
11	110-3823	1	Cover-Thermostat
12	98-7776	1	Gasket
13	98-7777	2	Bolt
14	110-3824	1	Water Pump ASM
15	100-1933	1	Flange-Pump, Water
16	100-1934	1	Bearing-Ball
17	99-3518	1	Water Pump Seal ASM
18	110-3825	1	Impeller-Pump, Water
19	100-1932	1	Pipe-Return, Water
20	110-3826	1	Gasket-Pump, Water
21	100-1750	4	Bolt
22	100-1918	1	Pipe-Water
23	110-3827	1	Pipe-Water
24	100-1924	1	Stud

Ref	Part No.	Qty.	Description
25	100-2203	1	Nut-Flange
26	110-3828	2	Band-Pipe

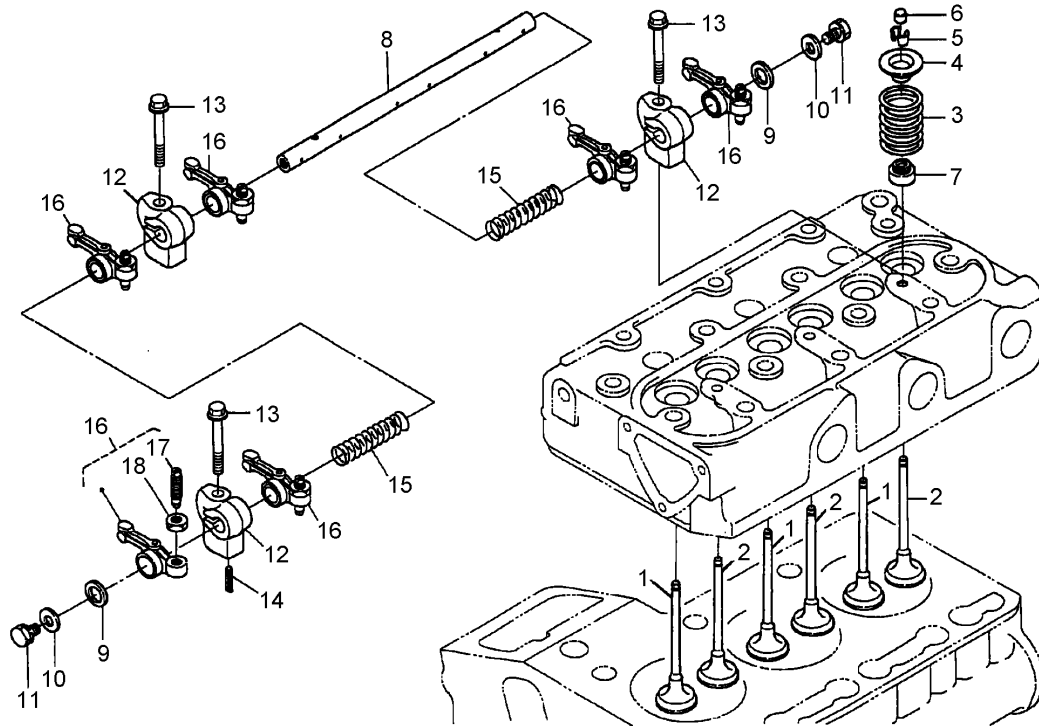

Valve and Rocker Arm Assembly

Ref	Part No.	Qty.	Description
1	112-2514	3	Valve-Inlet
2	112-2515	3	Valve-Exhaust
3	100-1823	6	Spring-Valve
4	100-1825	6	Retainer-Spring, Valve
5	100-1826	6	Collet-Spring, Valve
6	100-1824	6	Cap-Valve
7	100-1797	6	Seal-Stem, Valve
8	110-3831	1	Shaft-Arm, Rocker
9	100-2044	2	Washer
10	110-3832	2	Washer-Plain
11	100-1762	2	Bolt
12	110-3833	3	Bracket-Arm, Rocker
13	110-3834	3	Bolt-Flange
14	98-7602	1	Pin-Spring
15	110-3835	2	Spring
16	100-1884	6	Rocker Arm ASM
17	100-1885	6	Screw-Adjusting
18	100-1827	6	Nut

--	--	--	--

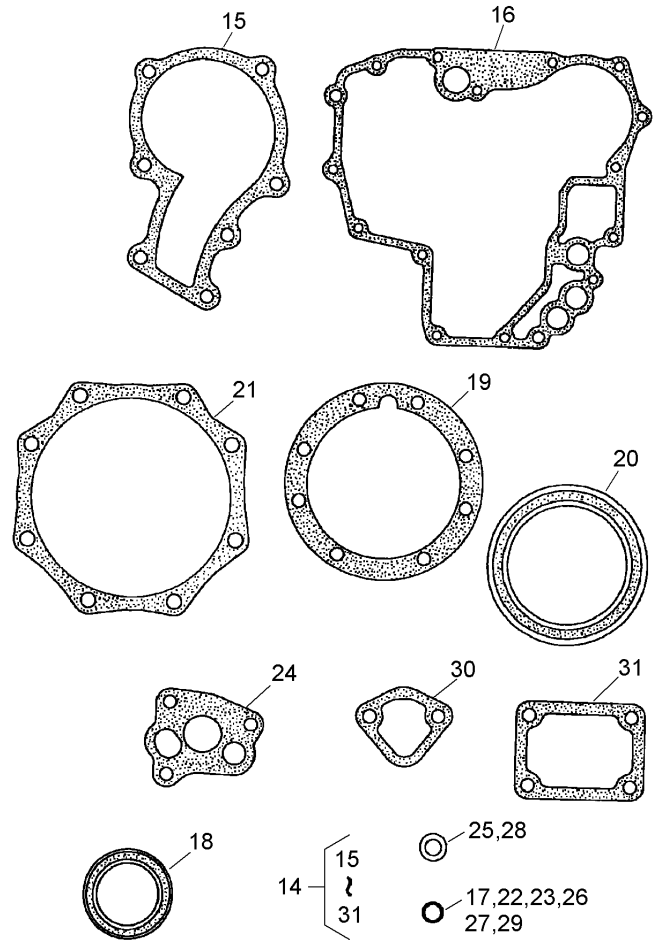
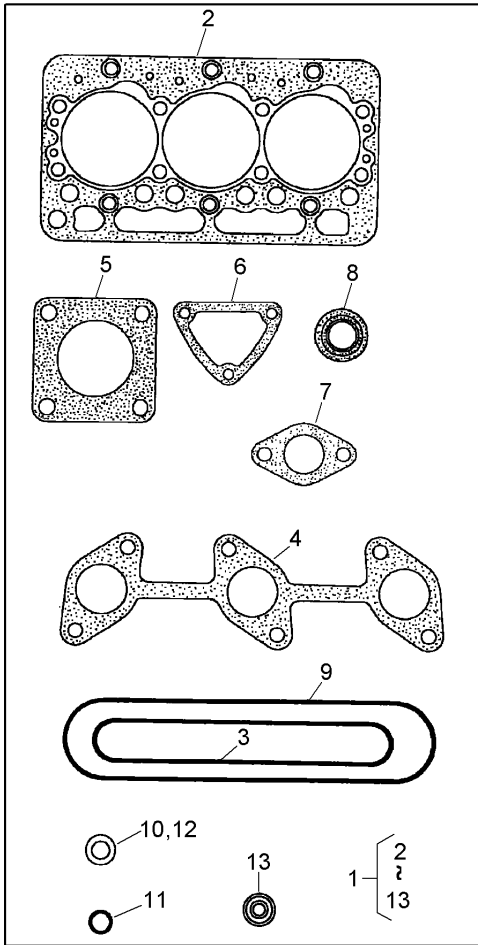

Gasket Kit

Ref	Part No.	Qty.	Description
1	110-3844	1	Upper Gasket Kit
2	110-3706	1	Gasket-Head, Cylinder
3	110-3838	1	Gasket-Manifold, Intake
4	110-3840	1	Gasket-Manifold, Exhaust
5	99-8343	1	Gasket-Muffler
6	110-3820	1	Gasket-Flange, Water
7	98-7776	1	Gasket
8	100-1797	6	Seal-Stem, Valve
9	110-3717	1	Gasket-Cover, Head
10	110-3846	1	O Ring-Breather
11	99-3446	1	O-Ring
12	98-7676	3	Gasket
13	98-7677	3	Seal
14	110-3847	1	Lower Gasket Kit
15	100-1976	1	Gasket-Pump, Water
16	110-3707	1	Case-Gear
17	98-7509	1	O-Ring
18	100-1971	1	Seal-Oil
19	100-1873	1	Gasket-Case, Bearing
20	110-3724	1	Seal-Oil
21	100-1876	1	Gasket-Case, Bearing
22	100-1785	3	O-Ring
23	100-2209	1	O-Ring
24	100-1958	1	Gasket-Pump, Oil

Ref	Part No.	Qty.	Description
25	98-7654	3	Gasket
26	100-2208	1	O-Ring
27	100-2207	1	O-Ring
28	98-9399	3	Gasket
29	100-2205	1	O-Ring
30	100-1961	1	Gasket-Pump, Fuel
31	100-1962	1	Gasket

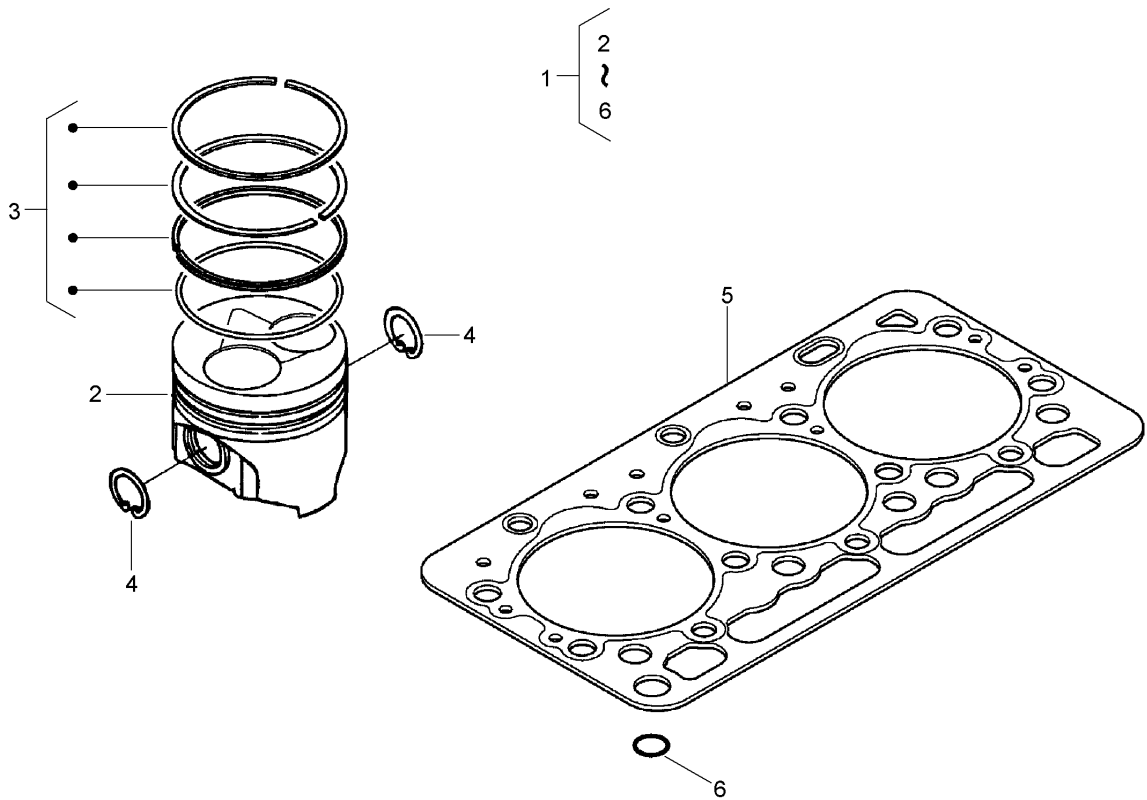

Piston Kit

Ref	Part No.	Qty.	Description
1	110-3848	1	Piston Kit
2	112-8398	3	Piston STD
3	110-3732	3	Piston Ring ASM (STD)
4	100-1835	6	Clip-Pin, Piston
5	110-3706	1	Gasket-Head, Cylinder
6	98-7509	1	O-Ring

--	--	--	--

Attachments and Accessories

For 74279TE - Z593-D Z Master, With 52 Rear Discharge Mower

Product Name	Model/Part
Blade-Recycler, 18 Inch	105-7779-03
Blade-Hi Flow, 18 Inch	105-7781-03
Blade-Med Flow, 18 Inch	105-7794-03
Blade-Low Flow, 18 Inch	105-7795-03
Blade-Atomic, 18 Inch	105-7796-03
Light Kit	107-9880
Blade-Hi-Flow, 18 Inch (6 Pack)	108-1117
Blade-Atomic, 18 Inch (6 Pack)	108-1118
Blade-Lo-Flow, 18 Inch (6 Pack)	110-0406
Blade-Recycler, 18 Inch (6 Pack)	110-0408
Blade-Med-Flow, 18 Inch (6 Pack)	110-0409
Sunshade-Bimini	110-5726
Recycler Kit 52 Inch Rdd	114-1820
Filter Minder Gauge	99-4664
Hitch Kit	99-8925

NOTES

NOTES

NOTES

