



PT21 Lawn Mower

Model No. 22164 - 270003001 and up.

Parts Catalog

Ordering Replacement Parts

To order replacement parts, please supply the part number, the quantity, and the description of each part desired.

Understanding Reference Numbers

Each Identified part in an illustration has a reference number. The reference number for a part also appears in the parts list, along with other information about the part.

This catalog uses two special reference number formats, one to indicate parts in a service assembly and another to indicate the quantity of a given part in an illustration.

Service Assembly Reference Numbers

Parts in service assemblies have reference numbers in the form a:b. The a represents the reference number of the entire service assembly and the b represents a sequential number unique to each part within the service assembly.

For example, a wheel assembly might be identified by reference number 6, the tire by 6:1, the valve by 6:2, and the wheel by 6:3. When you order the assembly identified by reference number 6, you receive all parts identified by reference numbers 6:1, 6:2, and 6:3. However, you may also order any part individually. Reference numbers of this type appear in illustrations and in part lists.

Reference Numbers Indicating Quantity

In an illustration, if a reference number indicates more than one part, the reference number has the form nX y. The n represents the quantity of the part, the X is the multiplication symbol, and the y represents the reference number.

For example, in an illustration, the reference number 2X 37 means that two of the parts identified by reference number 37 are indicated.

Contents

Description	Page	Description	Page
Housing Assembly 3	Lubrication Equipment Assembly Kawasaki FJ180V-AS28 15
Housing Assembly No. 108-4750 4	Cooling Equipment Assembly Kawasaki FJ180V-AS28 16
Height-of-Cut Assembly 5	Electric Equipment Assembly Kawasaki FJ180V-AS28 17
Front Wheel and Tire Assembly No. 100-2870 6	Control Equipment Assembly Kawasaki FJ180V-AS28 18
Transmission Assembly 7	Carburetor Assembly Kawasaki FJ180V-AS28 19
Rear Wheel Assembly No. 100-2860 8	Air Filter and Muffler Assembly Kawasaki FJ180V-AS28 20
Gear Case Assembly No. 108-8140 9	Fuel Tank and Fuel Valve Assembly Kawasaki FJ180V-AS28 21
Engine Assembly 10	Starter Assembly Kawasaki FJ180V-AS28 22
Handle Assembly 11	Brake and Cover Assembly Kawasaki FJ180V-AS28 23
Cylinder and Crankcase Assembly Kawasaki FJ180V-AS28 12	Decal Assembly Kawasaki FJ180V-AS28 24
Piston and Crankshaft Assembly Kawasaki FJ180V-AS28 13	Attachments and Accessories List 25
Valve and Camshaft Assembly Kawasaki FJ180V-AS28 14		

Part Description Abbreviations

Part descriptions in this catalog may include the following abbreviations.

AR. as required	HYD. hydraulic
ASM. assembly	LH. left hand
BBC. blade brake clutch	NI. nylon insert
CARR. carriage	NPTF. national pipe thread fine
DEG. degrees	PFH. phillips flat head
EXT. external	PPH. phillips pan head
FH. flat head	PPHTF. phillips pan head thread forming
GA. gauge	PRH. phillips round head
HD. heavy-duty	PTH. phillips truss head
HF. hex flange	PTO. power-take-off
HH. hex head	RH. right hand
HHF. hex head flange	ROPS. roll-over protection system
HHFTF. hex head flange thread forming	SFH. slotted fillister head
HJ. hex jam	SHH. slotted hex head
HLH. hex lag head	SHWH. slotted hex washer head
HOC. height-of-cut	SPH. slotted pan head
HSBH. hex socket button head	SQH. square head
HSFH. hex socket flat head	SRH. slotted round head
HSH. hex socket head	STD. standard
HWH. hex washer head	TAP. self tapping
HWHTF. hex washer head thread forming	TTH. torx truss head

Footnotes

- ❶ Not serviced separately
- ❷ Obtain from your local Kawasaki dealer
- ❸ For use only on Models with BBC

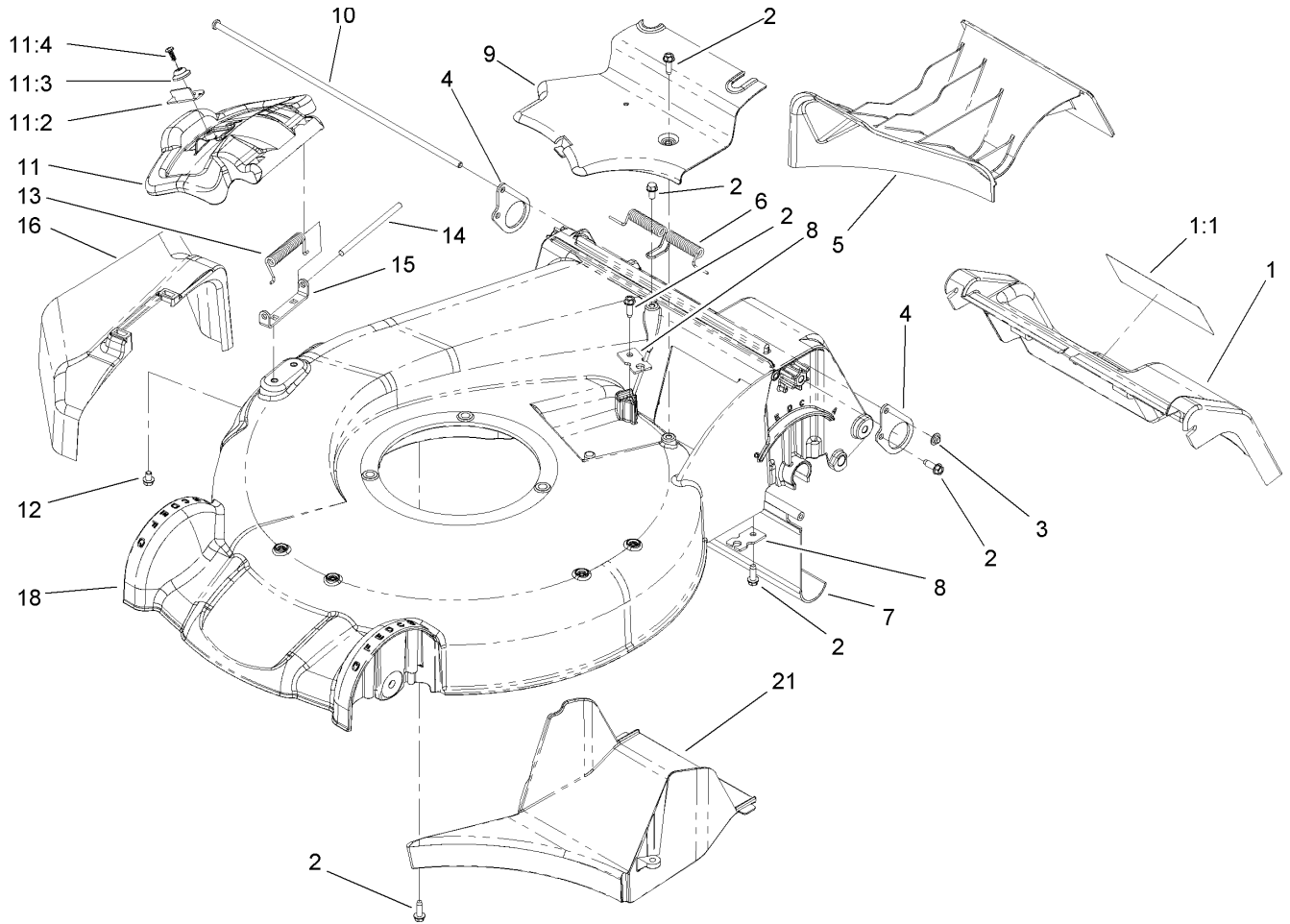

Housing Assembly

Ref	Part No.	Qty.	Description
1	108-8169	1	Door-Service
1:1	105-1295	1	Decal-Warning
2	49-2040	7	Screw-HWHTF
3	3290-337	1	Nut-Speed
4	107-7493	2	Plate-Support, Door
5	107-7490	1	Plug-Mulch
6	105-3032	1	Spring-Door, Rear
7	114-1586	1	Shield-Trailing
8	107-7497	1	Bracket-Cable, Traction
9	107-7494	1	Cover-Belt
10	107-7499	1	Rod-Support, Door
11	107-3717	1	Discharge Door ASM
11:2	107-0795	1	Latch-Door
11:3	107-7456	1	Cap-Door
11:4	107-7461	1	Screw-Plastite
12	99-8445	2	Screw-HWH
13	99-5293	1	Spring-Torsion
14	99-5291	1	Rod-Cover
15	112-6416	1	Bracket-Cover
16	108-3753	1	Chute-Discharge, Side
18	108-4750	1	Housing ASM
21	107-7495	1	Tunnel-Discharge

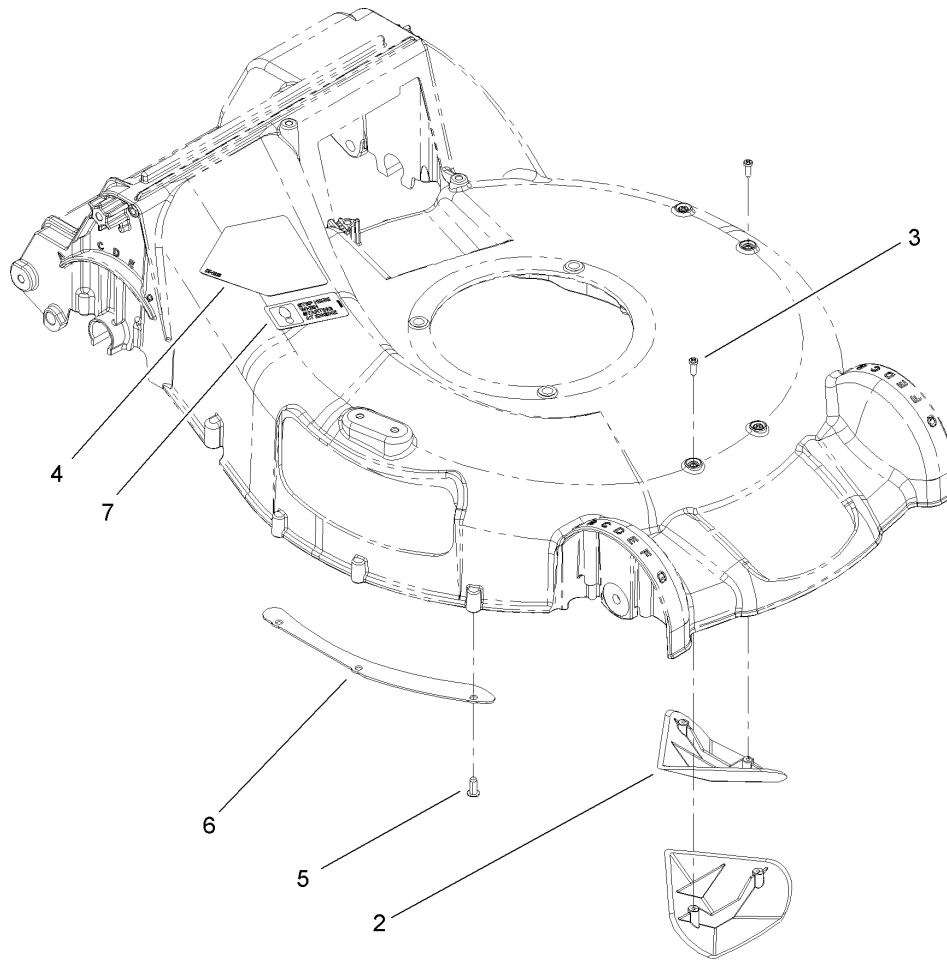

Housing Assembly No. 108-4750

Ref	Part No.	Qty.	Description				
2	108-3798	2	Kicker-Housing				
3	32144-111	4	Screw-PPH				
4	105-6838	1	Decal-Danger				
5	63-8590	3	Screw				
6	105-1316-03	1	Sheet-Lip				
7	108-8117	1	Decal-Placement, Foot				

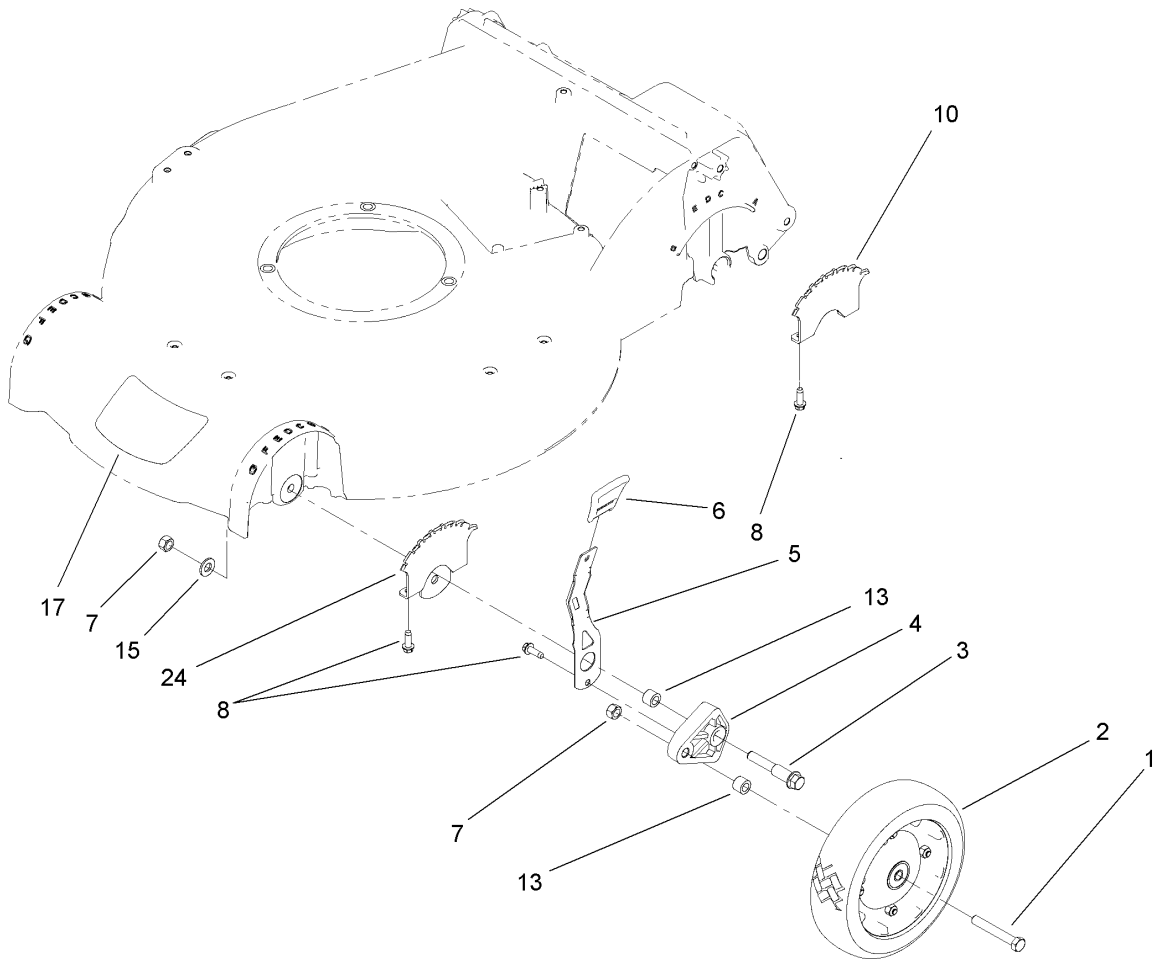

Height-of-Cut Assembly

Ref	Part No.	Qty.	Description
1	323-12	2	Screw-HH
2	100-2870	2	Wheel And Tire ASM
3	107-7498	2	Screw-Shoulder, HOC
4	107-7492	2	Arm-Pivot
5	107-7491	2	Arm-Spring
6	110-0549	2	Knob-HOC
7	603773	4	Nut
8	49-2040	10	Screw-HWHTF
10	107-7478	2	Plate-HOC
13	52-2480	4	Spacer-Wheel
15	3256-24	2	Washer-Flat
17	110-4929	1	Decal-Housing, Front
24	110-4920-03	2	Bracket-Support

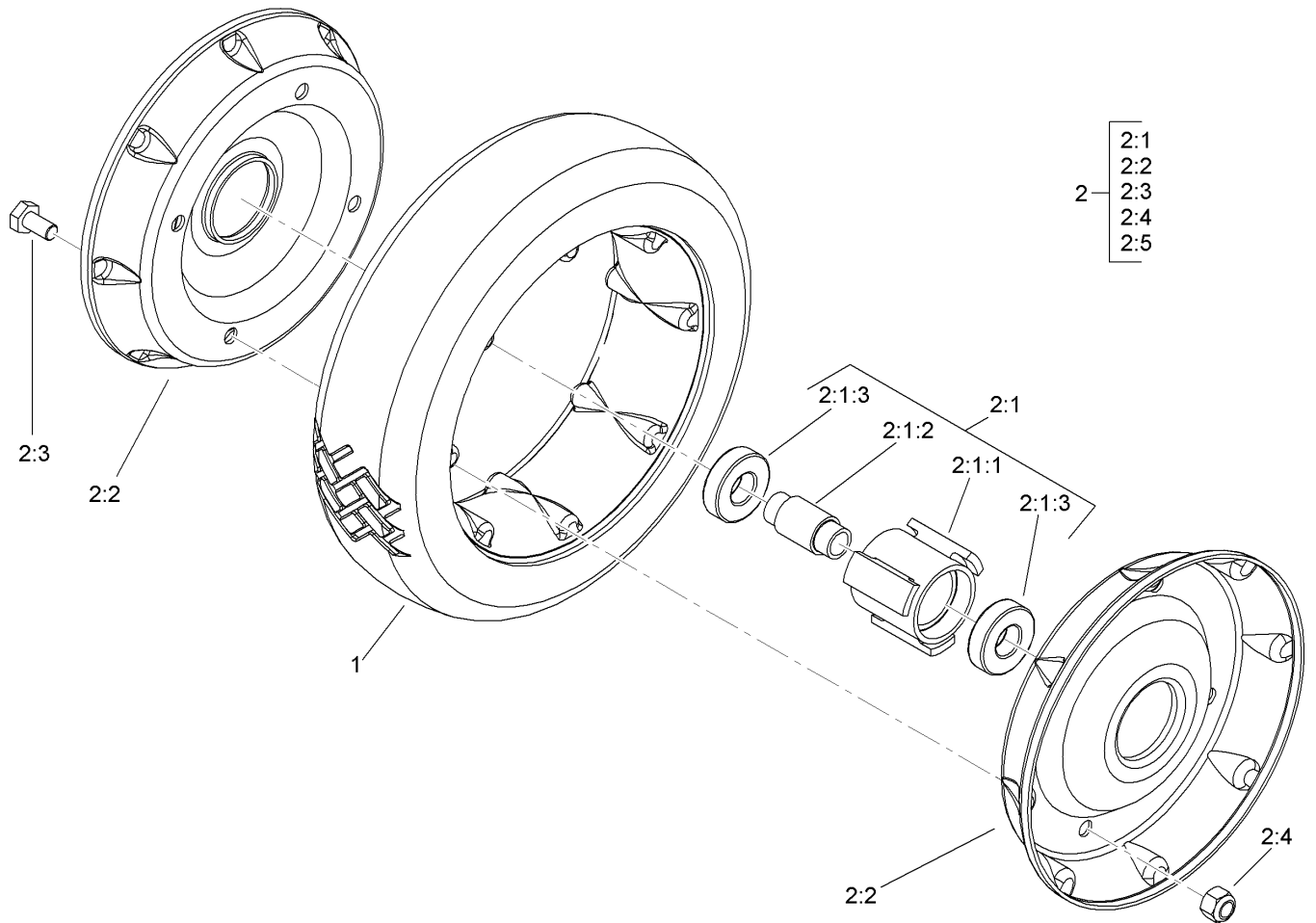

Front Wheel and Tire Assembly No. 100-2870

Ref	Part No.	Qty.	Description
1	53-7740	1	Tire
2		1	Wheel ASM
2:1		1	Hub And Bearing ASM
2:1:1	52-2410	1	Hub-Bearing
2:1:2	52-2440	1	Spacer-Bearing
2:1:3	52-2450	2	Bearing-Wheel
2:2	53-7780-06	2	Plate-Wheel, Half
2:3	321-2	4	Screw-HH
2:4	3296-42	4	Nut-Lock, NI

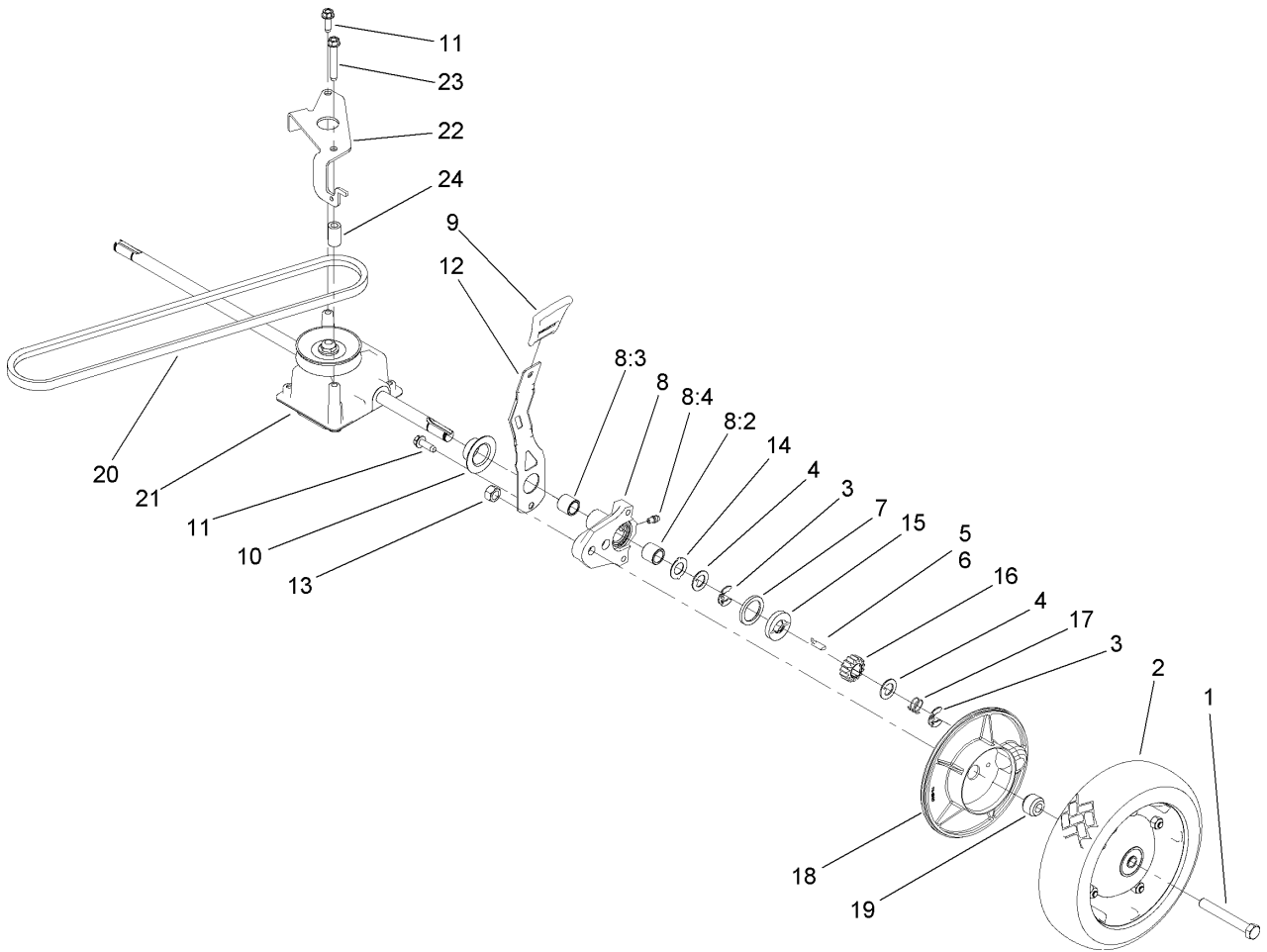

Transmission Assembly

Ref	Part No.	Qty.	Description
1	323-13	2	Screw-HH
2	100-2860	2	Wheel And Tire ASM
3	65-2720	4	Ring-Clip, Locking
4	65-4740	4	Washer-Thrust, Keyed
5	66-6040	1	Key-Rocking, RH
6	66-6050	1	Key-Rocking, LH
7	65-4710	2	Ring-Friction
8	100-8774	2	Pivot Arm ASM
8:2	47-2900	1	Bushing
8:3	70-9760	1	Bushing
8:4	302-56	1	Fitting-Grease
9	110-0549	2	Knob-HOC
10	42-3520	2	Cap-End
11	49-2040	3	Screw-HWHTF
12	107-7491	2	Arm-Spring
13	603773	2	Nut
14	65-4730	2	Washer-Arm, Pivot
15	65-4760	2	Washer-Clutch
16	65-4750	2	Gear-Pinion
17	65-4720	2	Spring-Compression
18	74-1640	2	Cover-Wheel
19	74-1650	2	Spacer-Cover, Wheel
20	99-1597	1	V-Belt
21	108-8140	1	Gear Case ASM

Ref	Part No.	Qty.	Description
22	107-7483-03	1	Bracket-Gearbox
23	92-1616	1	Screw-HWHTF
24	614673	1	Bushing-Plate, Actuator

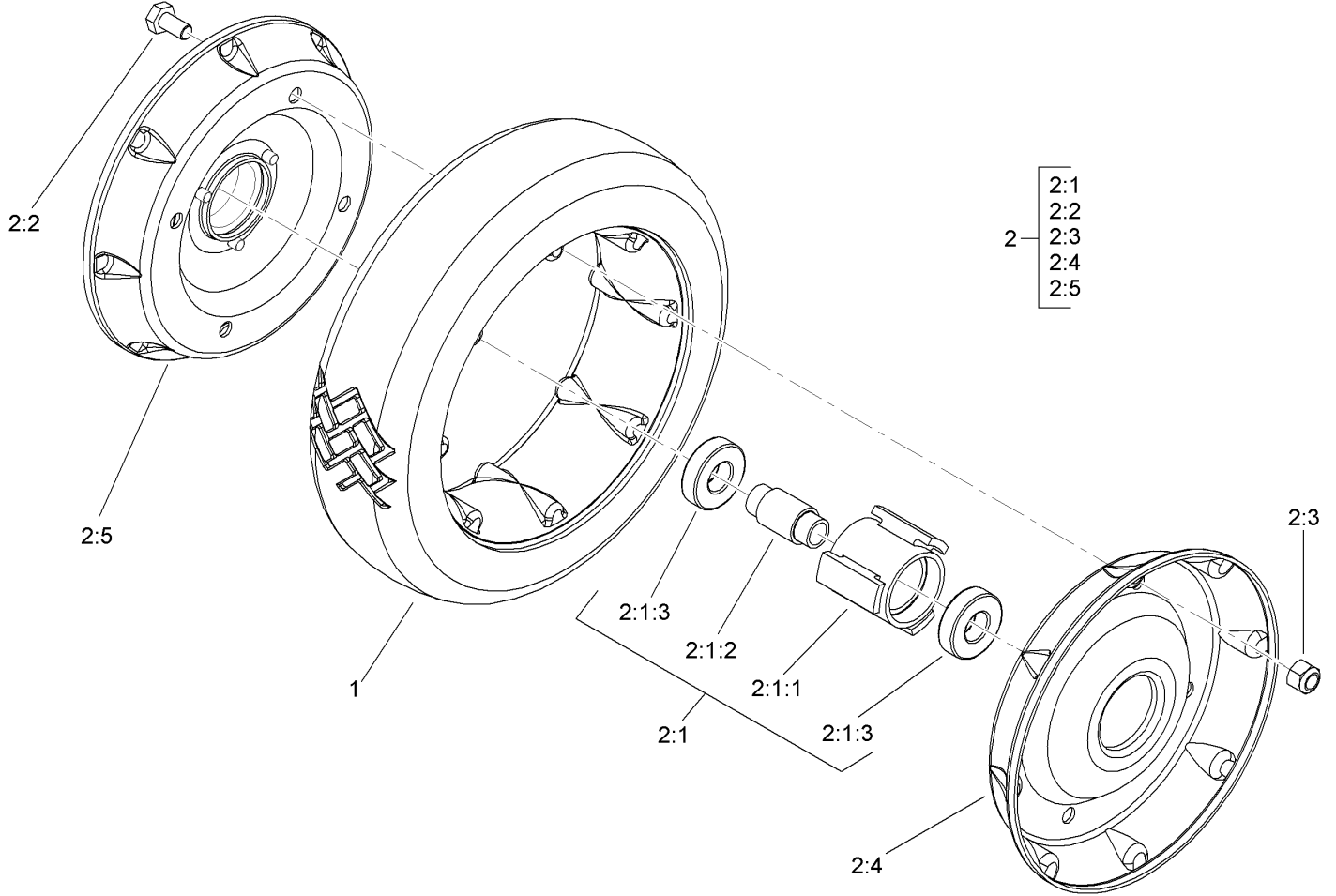

Rear Wheel Assembly No. 100-2860

Ref	Part No.	Qty.	Description
1	53-7740	1	Tire
①2		1	Wheel ASM
①2:1		1	Hub And Bearing ASM
2:1:1	52-2410	1	Hub-Bearing
2:1:2	52-2440	1	Spacer-Bearing
2:1:3	52-2450	2	Bearing-Wheel
2:2	321-2	4	Screw-HH
2:3	3296-42	4	Nut-Lock, NI
2:4	53-7780-06	1	Plate-Wheel, Half
2:5	92-4957-06	1	Wheel Half And Gear ASM

Ref	Part No.	Qty.	Description

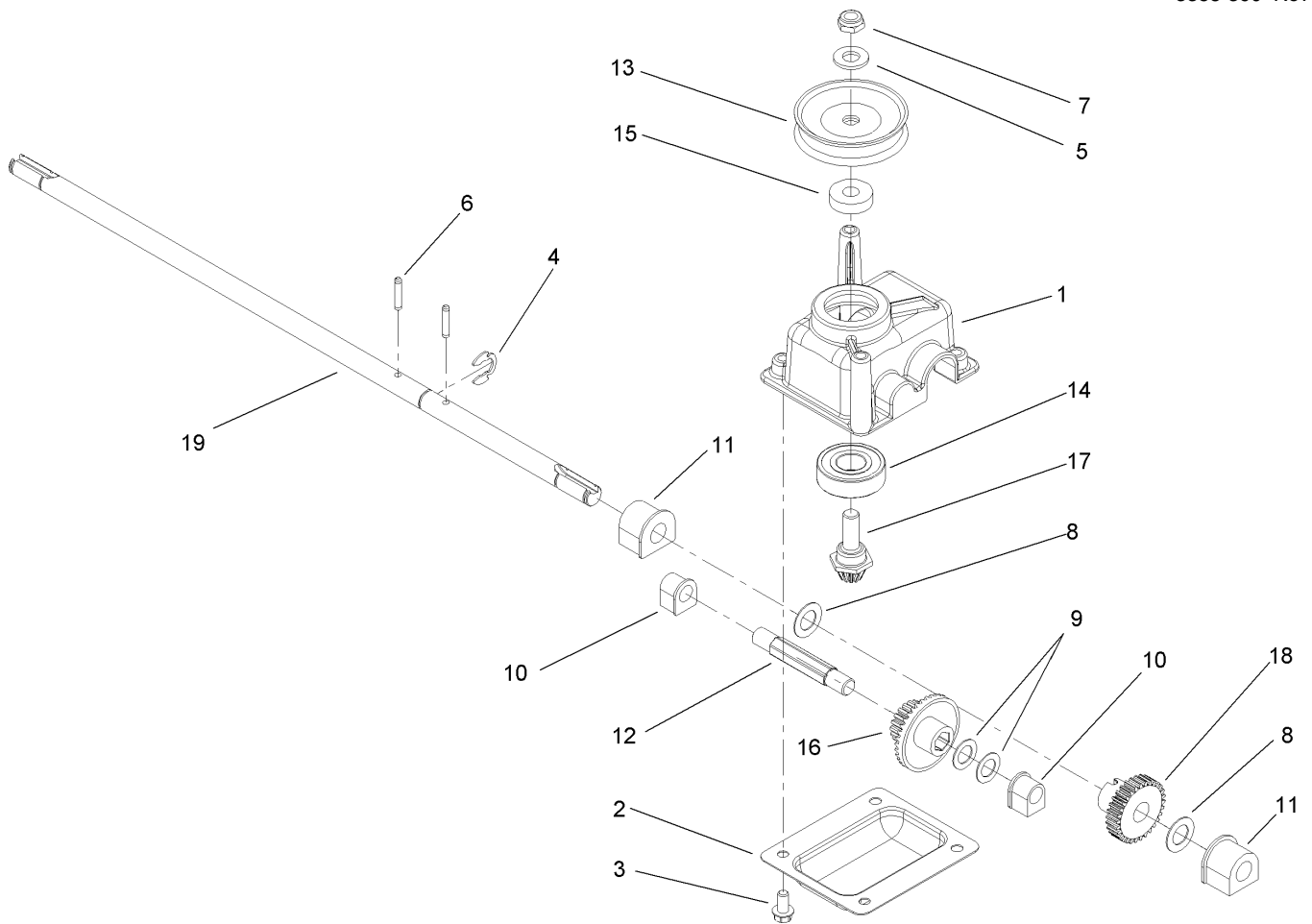

Gear Case Assembly No. 108-8140

Ref	Part No.	Qty.	Description
1	104-7619	1	Case-Gear
2	614668-03	1	Cover-Case, Gear
3	32144-4	4	Screw-HWH
4	32151-68	1	Ring-Retaining
5	3256-24	1	Washer-Flat
6	3285-19	2	Pin-Groove
7	3296-5	1	Nut-Lock
8	36-4780	2	Washer-Plain
9	36-4791	2	Washer-Thrust
10	60-8750	2	Bushing
11	60-8850	2	Bushing
12	614696	1	Shaft-Intermediate
13	100-1176	2	Pulley-Half
14	100-1048	1	Bearing-Ball
15	62-6660	1	Spacer
16	104-1005	1	Gear-19T Spur, 37T Bevel
17	104-7667	1	Gear-Pinion, Bevel
18	104-1004	1	Gear-30T
19	108-8141	1	Shaft-Output

--	--	--	--

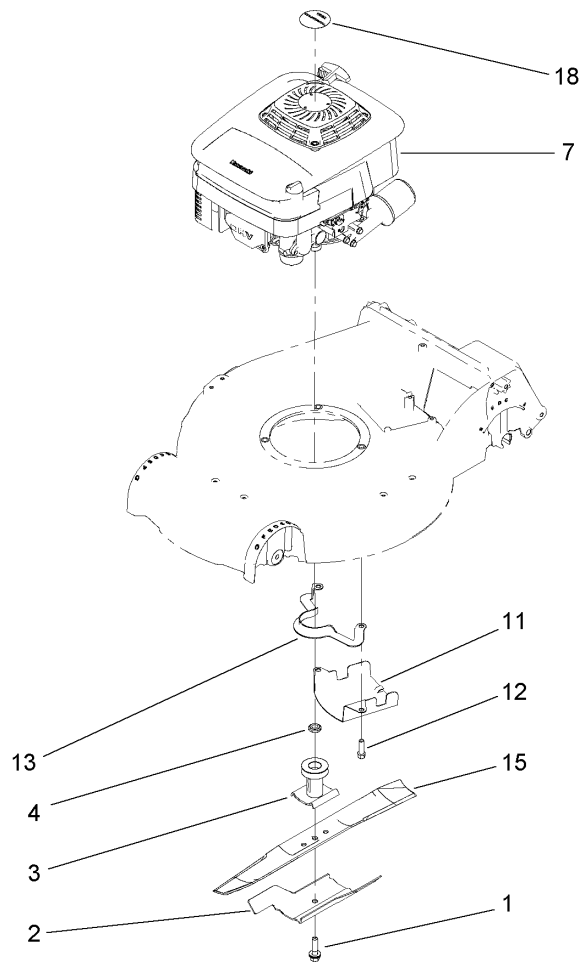

Engine Assembly

Ref	Part No.	Qty.	Description				
1	105-8579	1	Bolt-Blade				
2	105-6848-03	1	Accelerator-Blade				
3	106-3987	1	Blade Driver ASM				
4	106-3999	1	Spacer-Driver				
7	112-9990	1	Engine-Kawasaki, Fj180V-As28				
11	107-7489-03	1	Shield-Grass				
12	95-1727	3	Screw-Taptite				
13	108-8110-03	1	Guide-Belt				
15	108-3762-03	1	Blade-Recycling				
18	112-9966	1	Decal				

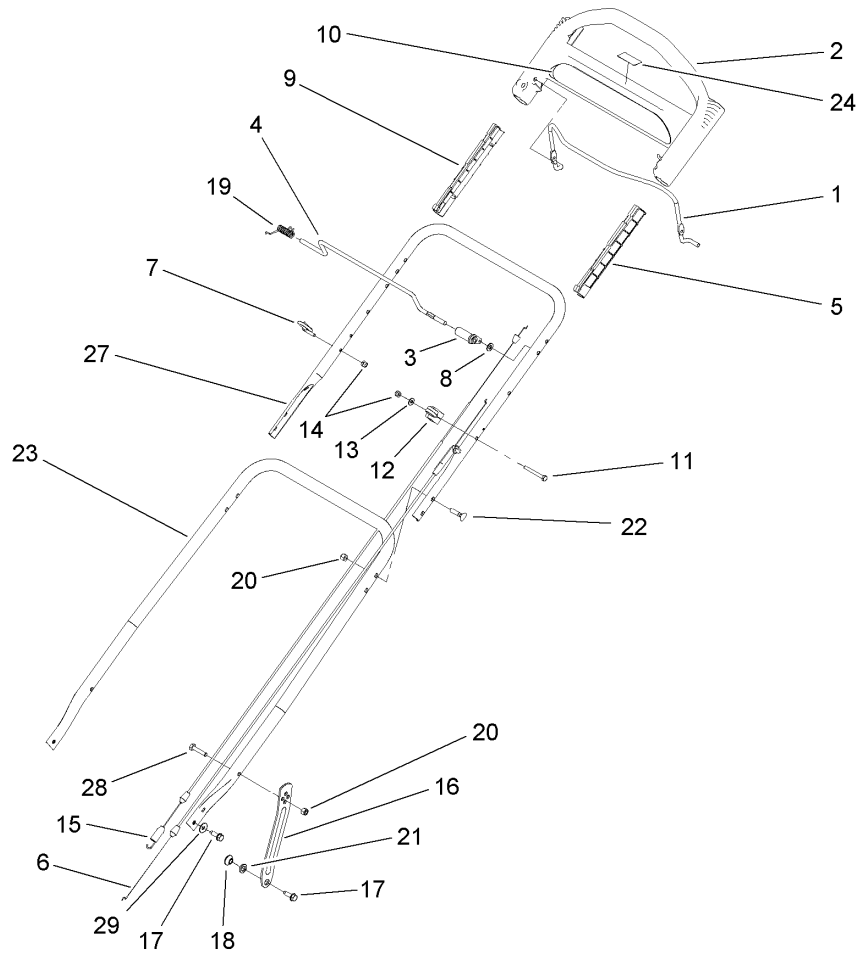

Handle Assembly

Ref	Part No.	Qty.	Description
1	104-8679-03	1	Bail-Brake
2	104-8678	1	Handle-Control
3	99-1589	1	Lever-Traction
4	99-1588	1	Bar-Control, Traction
5	105-6842	1	Guide-LH
6	106-5750	1	Cable-Brake
7	86-9671	1	Guide-Rope
8	3256-23	1	Washer-Flat
9	105-6841	1	Guide-RH
10	108-8134	1	Decal-Handle
11	95-4453	1	Screw
12	99-5239	1	Anchor-Cable
13	3256-1	1	Washer-Flat
14	3296-73	2	Nut-Lock, NI
15	108-8158	1	Cable-Traction
16	108-8145-03	2	Support-Handle
17	701243	4	Screw-HWHTF
18	27-6600	2	Spacer-Coupling
19	104-8690	1	Spring-Torsion
20	3296-29	6	Nut-Lock, NI
21	55-9670	2	Washer
22	92-4095	4	Screw-Handle
23	112-9720-03	1	Handle-Lower
24	98-4387	1	Decal-Protection, Ear

Ref	Part No.	Qty.	Description
27	110-4874-03	1	Handle-Upper
28	322-7	2	Screw-HH
29	3290-456	2	Washer-Belleville

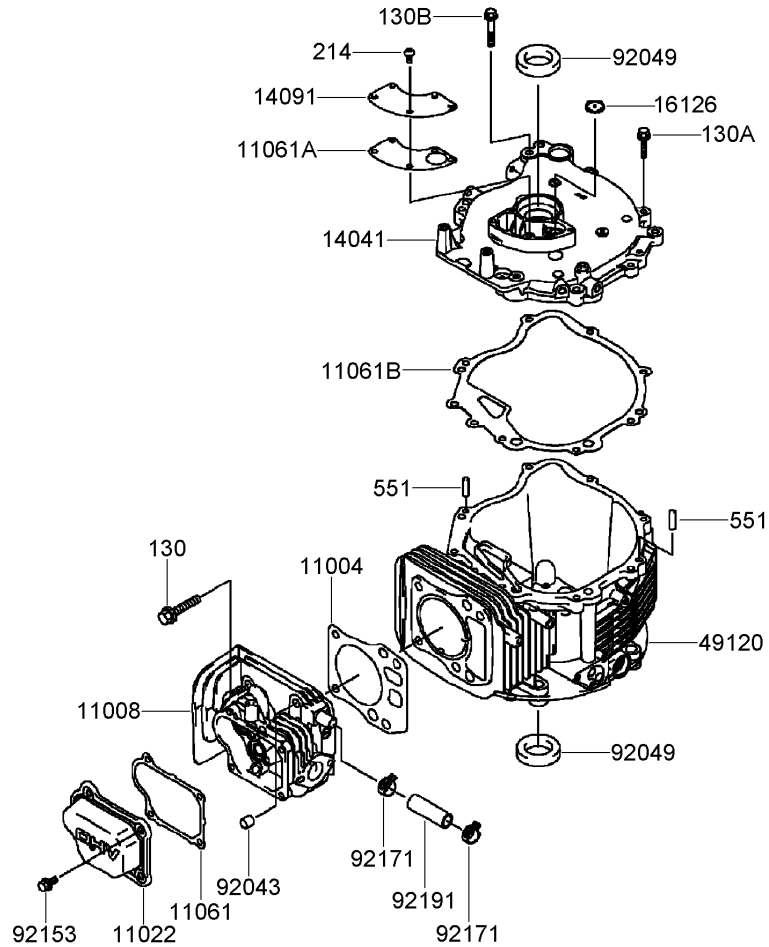

Cylinder and Crankcase Assembly Kawasaki FJ180V-AS28

Ref	Part No.	Qty.	Description
②11004	11004-7020	1	Gasket-Head
②11008	11008-7025	1	Head-Cylinder
②11022	11022-7005	1	Case-Rocker
②11061	11061-7023	1	Gasket-Case, Rocker
②11061A	11061-7031	1	Gasket-Breather
②11061B	11061-7060	1	Gasket-Cover, Crankcase
②14041	14041-7009	1	Cover
②14091	14091-7010	1	Cover-Breather
②16126	16126-7014	1	Valve-Breather
②49120	49120-7082	1	Crankcase
②92043	92043-7001	2	Pin
②92049	92049-7008	2	Seal-Oil (28-44-9 Tc)
②92153	92153-7043	4	Bolt (6X12)
②92171	92171-7024	2	Clamp
②92191	92191-7025	1	Tube (12X16X49)
②130	130CA0840	4	Bolt-Flanged (8X40)
②130A	130G0625	7	Bolt-Flanged (6X25)
②130B	130G0635	1	Bolt-Flanged (6X35)
②214	214B0510	5	Screw-Pan (5X10)
②551	551A0612	2	Pin-Dowel (6X12)

--	--	--	--

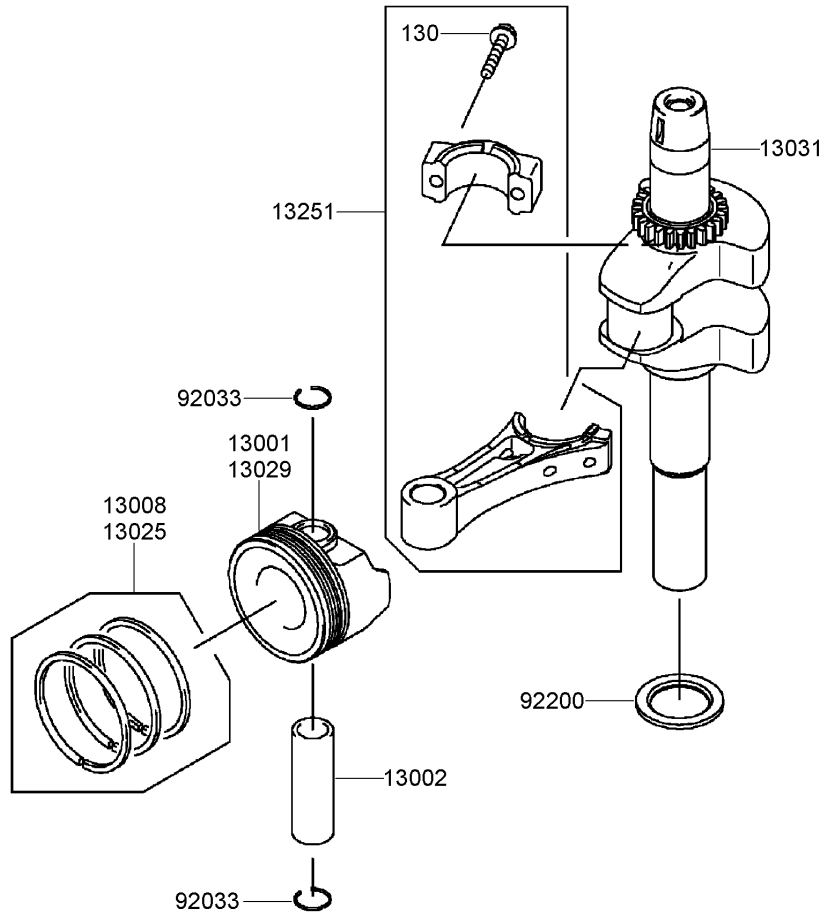

Piston and Crankshaft Assembly Kawasaki FJ180V-AS28

Ref	Part No.	Qty.	Description
② 13001	13001-7022	1	Piston-Engine
② 13002	13002-7001	1	Pin-Piston
② 13008	13008-7002	1	Ring Set-Piston
② 13025	13025-7006	1	Ring Set-Piston (L 0.50)
② 13029	13029-7005	1	Piston-Engine (L 0.50)
② 13031	13031-7078	1	Crankshaft
② 13251	13251-7011	1	Connecting Rod ASM
② 92033	92033-7002	2	Ring-Snap
② 92200	92200-7042	1	Washer (28X41.5X2.5)
② 130	130G0630	2	Bolt-Flanged (6X30)

--	--	--	--

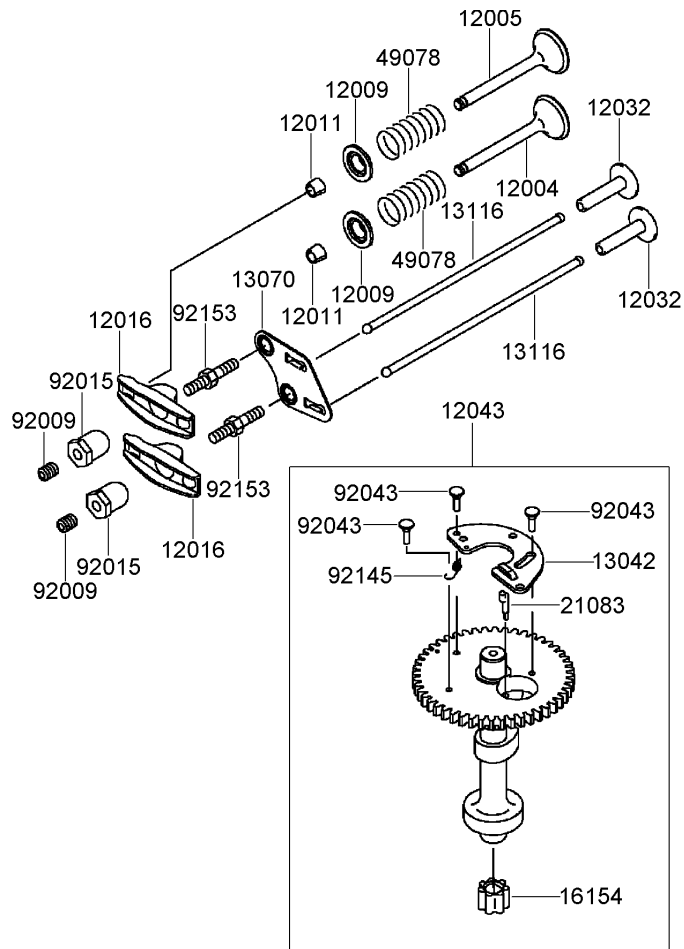

Valve and Camshaft Assembly Kawasaki FJ180V-AS28

Ref	Part No.	Qty.	Description
②	12004	1	Valve-Intake
②	12005	1	Valve-Exhaust
②	12009	2	Retainer-Spring, Valve
②	12011	4	Collet
②	12016	2	Arm-Rocker
②	12032	2	Tappet
②	12043	1	Camshaft Valve ASM
②	13042	1	Weight
②	13070	1	Guide
②	13116	2	Rod-Push
②	16154	1	Rotor-Pump
②	21083	1	Arm
②	49078	2	Spring-Valve, Engine
②	92009	2	Screw
②	92015	2	Nut
②	92043	3	Pin
②	92145	1	Spring
②	92153	2	Bolt

--	--	--	--

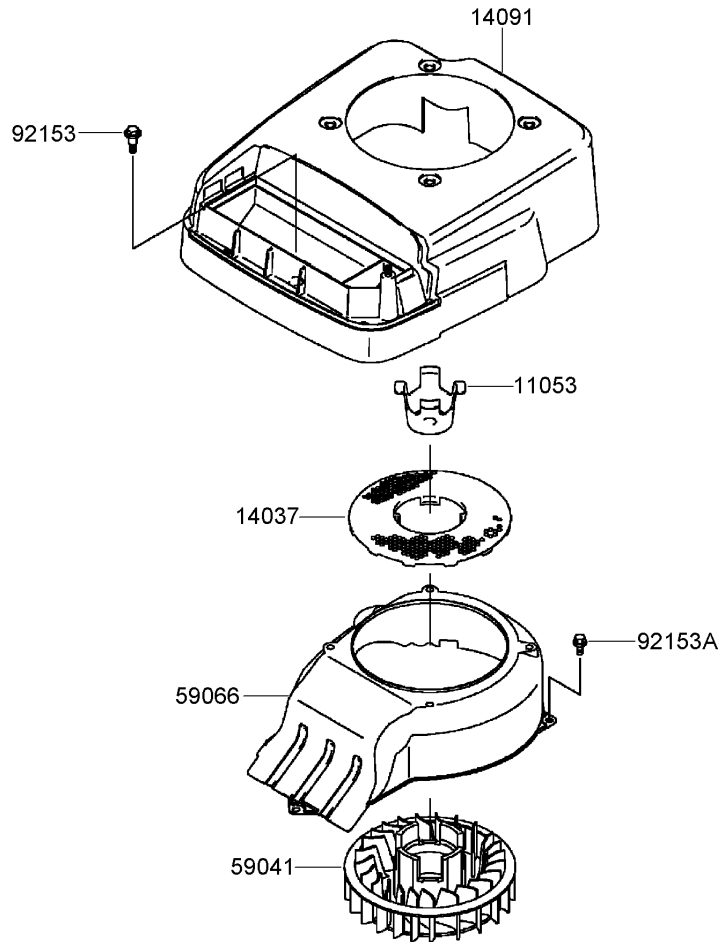

Cooling Equipment Assembly Kawasaki FJ180V-AS28

Ref	Part No.	Qty.	Description				
② 11053	11053-7009	1	Bracket, Fan				
② 14037	14037-7017	1	Screen				
② 14091	14091-7046	1	Cover				
② 59041	59041-7009	1	Fan				
② 59066	59066-7016	1	Housing-Fan				
② 92153	92153-7008	1	Bolt				
② 92153A	92153-7043	1	Bolt (6X12)				

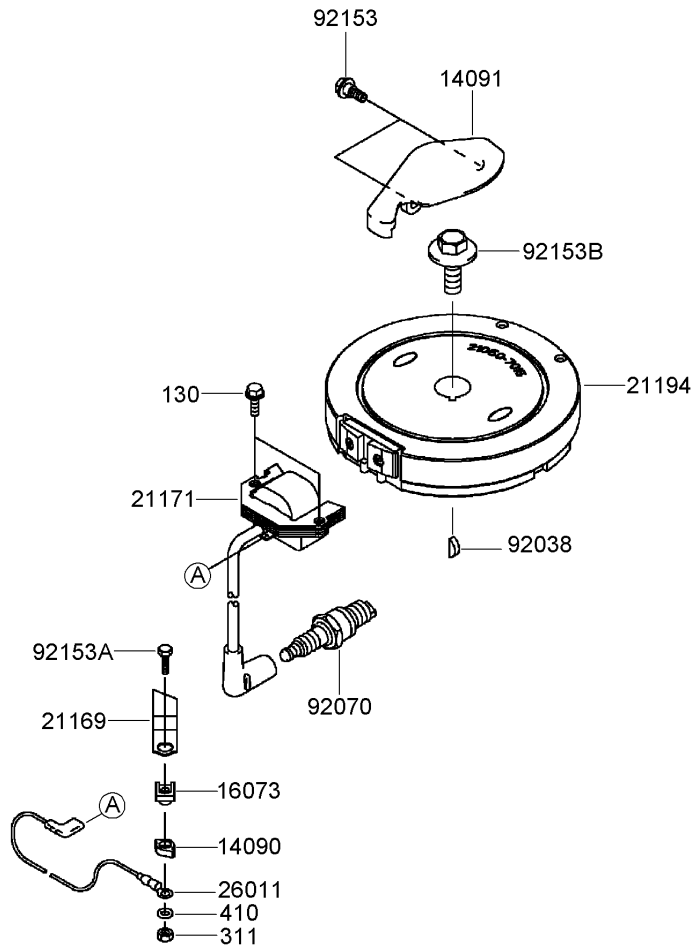

Electric Equipment Assembly Kawasaki FJ180V-AS28

Ref	Part No.	Qty.	Description
②14090	14090-2108	1	Cover
②14091	14091-7036	1	Cover
②16073	16073-2192	1	Insulator
②21169	21169-2071	1	Terminal
②21171	21171-7030	1	Ignition Coil ASM
②21194	21194-7024	1	Flywheel
②26011	26011-7013	1	Wire-Lead
②92038	92038-2077	1	Key
②92070	92070-2088	1	Spark Plug, B P R 5E S (N G K) Solid
②92153	92153-7007	2	Bolt
②92153A	92153-7012	1	Bolt (4X16)
②92153B	92153-7030	1	Bolt (12X30)
②130	130B0620	2	Bolt-Flanged (6X20)
②311	311B0400	1	Nut-Hex (4Mm)
②410	410B0400	1	Washer-Plain, S (4Mm)

--	--	--	--

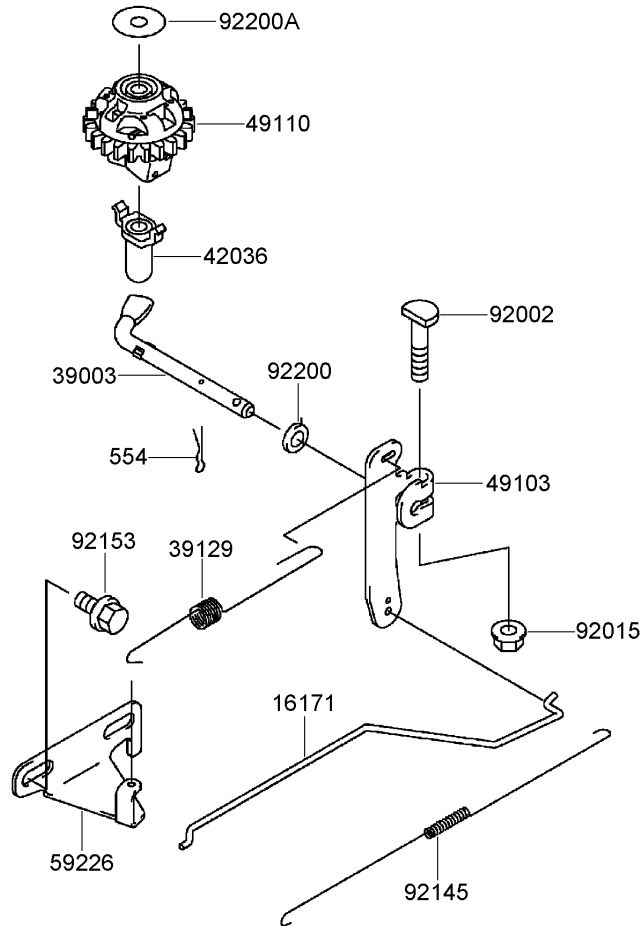

Control Equipment Assembly Kawasaki FJ180V-AS28

Ref	Part No.	Qty.	Description
②16171	16171-7015	1	Link-Throttle
②39003	39003-7002	1	Arm-Pivot
②39129	39129-7007	1	Spring-Governor
②42036	42036-2051	1	Sleeve
②49103	49103-7005	1	Arm-Governor
②49110	49110-7002	1	Governor ASM
②59226	59226-7014	1	Panel-Control
②92002	92002-2269	1	Bolt (6X28)
②92015	92015-1193	1	Nut
②92145	92145-7025	1	Spring-Throttle
②92153	92153-7043	2	Bolt (6X12)
②92200	92200-2029	1	Washer (6.5X11.5X2.0)
②92200A	92200-2036	1	Washer (6.2X20X0.5)
②554	554A0600	1	Pin-Snap (1.2X21.2)

--	--	--	--

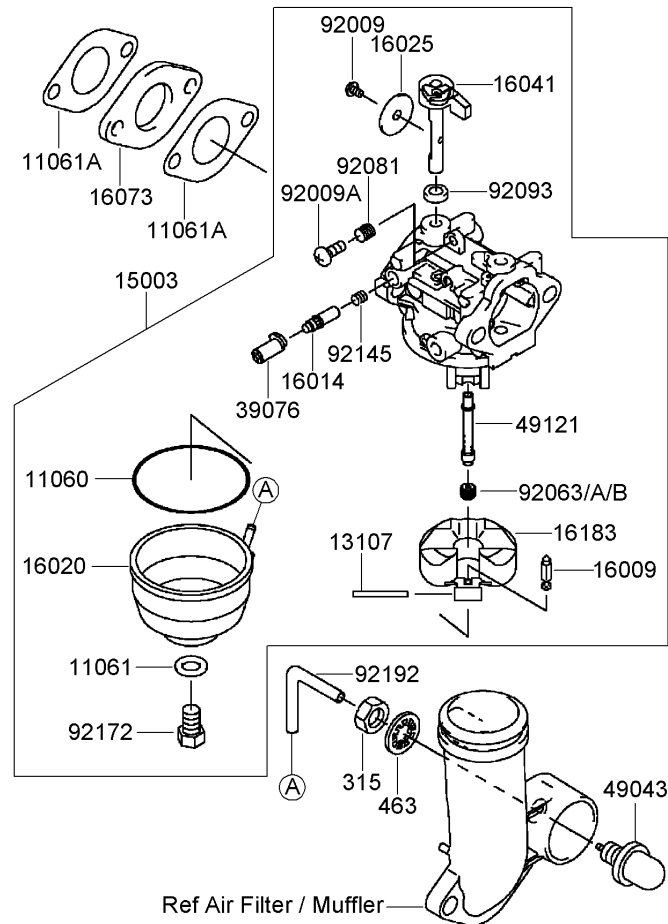

Carburetor Assembly Kawasaki FJ180V-AS28

Ref	Part No.	Qty.	Description
②11060	11060-2190	1	Gasket
②11061	11061-7010	1	Gasket-Screw
②11061A	11061-7015	2	Gasket-Insulator
②13107	13107-7024	1	Shaft
②15003	15003-7133	1	Carburetor ASM
②16009	16009-2136	1	Needle-Jet
②16014	16014-7008	1	Screw-Air, Pilot
②16020	16020-7005	1	Chamber-Float
②16025	16025-7007	1	Valve-Throttle
②16041	16041-7019	1	Shaft-Carburetor
②16073	16073-7006	1	Insulator
②16183	16183-2002	1	Float ASM
②39076	39076-7001	1	Limiter
②49043	49043-7002	1	Pump-Priming
②49121	49121-7012	1	Nozzle-Main
②92009	92009-2083	1	Screw
②92009A	92009-2349	1	Screw
②92063	92063-7048	1	Jet-Main, No. 76
②92063A	92063-7049	1	Jet-Main, No. 74
②92063B	92063-7061	1	Jet-Main, No. 78
②92081	92081-2234	1	Spring
②92093	92093-2100	1	Seal
②92145	92145-7015	1	Spring
②92172	92172-7023	1	Screw

Ref	Part No.	Qty.	Description
②92192	92192-7074	1	Tube (2.2X7.3X65)
②315	315B1000	1	Nut-Hex, Fine (10Mm)
②463	463H1000	1	Washer-Toothed (10Mm)

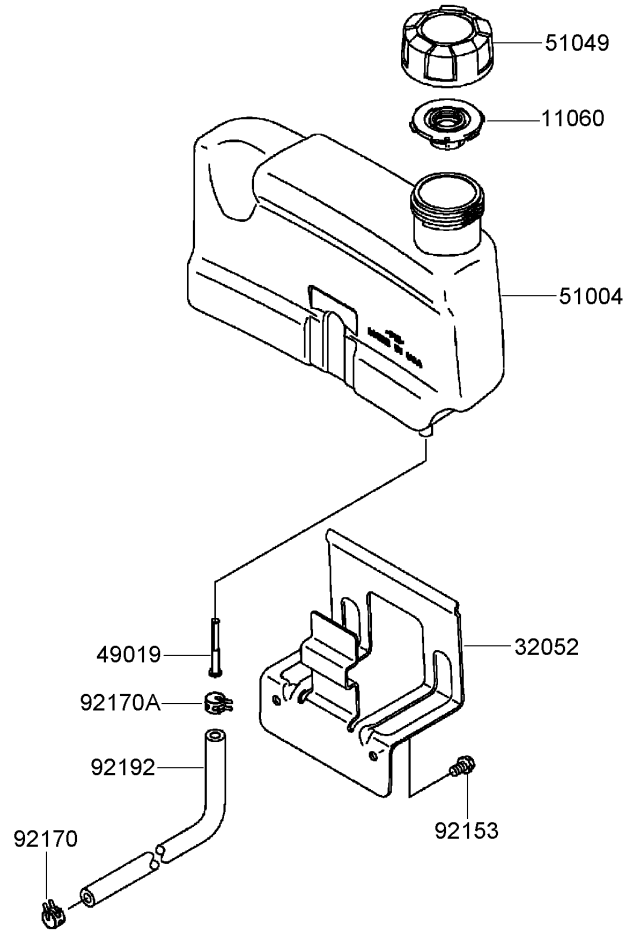

Fuel Tank and Fuel Valve Assembly Kawasaki FJ180V-AS28

Ref	Part No.	Qty.	Description				
②11060	11060-2145	1	Gasket				
②32052	32052-7001	1	Bracket-Tank				
②49019	49019-7003	1	Filter-Fuel				
②51004	51004-7001	1	Tank-Fuel				
②51049	51049-7002	1	Cap-Tank				
②92153	92153-7023	2	Bolt (6X10)				
②92170	92170-2009	1	Clamp				
②92170A	92170-2088	1	Clamp				
②92192	92192-7033	1	Tube (6.35X12.7X330)				

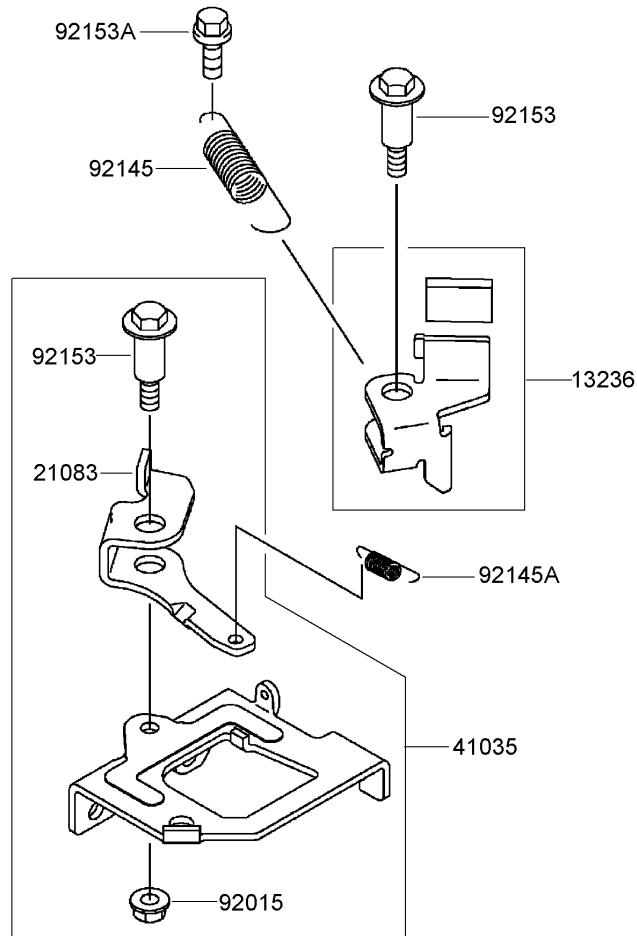

Brake and Cover Assembly Kawasaki FJ180V-AS28

Ref	Part No.	Qty.	Description
②13236	13236-7008	1	Lever
②21083	21083-7016	1	Arm
②41035	41035-7005	1	Brake Panel ASM
②92015	92015-1193	1	Nut
②92145	92145-7023	1	Spring
②92145A	92145-7032	1	Spring
②92153	92153-7020	2	Bolt
②92153A	92153-7023	1	Bolt (6X10)

--	--	--	--

Attachments and Accessories

For 22164 - PT21 Lawn Mower

Product Name

Model/Part

Bagging Kit 112-8700

NOTES

NOTES

