



## Power Clear Snowthrower

Model No. 38583 - 280000001 and up.

### Parts Catalog

---

#### **Ordering Replacement Parts**

To order replacement parts, please supply the part number, the quantity, and the description of each part desired.

#### **Understanding Reference Numbers**

Each identified part in an illustration has a reference number. The reference number for a part also appears in the parts list, along with other information about the part.

This catalog uses two special reference number formats, one to indicate parts in a service assembly and another to indicate the quantity of a given part in an illustration.

#### **Service Assembly Reference Numbers**

Parts in service assemblies have reference numbers in the form a:b. The a represents the reference number of the entire service assembly and the b represents a sequential number unique to each part within the service assembly.

For example, a wheel assembly might be identified by reference number 6, the tire by 6:1, the valve by 6:2, and the wheel by 6:3. When you order the assembly identified by reference number 6, you receive all parts identified by reference numbers 6:1, 6:2, and 6:3. However, you may also order any part individually. Reference numbers of this type appear in illustrations and in part lists.

#### **Reference Numbers Indicating Quantity**

In an illustration, if a reference number indicates more than one part, the reference number has the form nX y. The n represents the quantity of the part, the X is the multiplication symbol, and the y represents the reference number.

For example, in an illustration, the reference number 2X 37 means that two of the parts identified by reference number 37 are indicated.

# Contents

Description	Page	Description	Page
Rotor Housing and Scraper Assembly	..... 3	Quick Turn Assembly	..... 10
Rotor Drive Assembly	..... 4	Cylinder, Piston and Connecting Rod	
Chute Assembly	..... 5	Assemblies Briggs and Stratton 084232-0121- E8	..... 11
Rotor Assembly	..... 6	Muffler, Carburetor and Intake Manifold	
Engine, Frame and Wheel Assembly	..... 7	Assembly Briggs and Stratton 084232-0121-E8	..... 12
Shroud and Control Panel Assembly	..... 8	Flywheel, Blower Housing and Starter	
Handle Assembly	..... 9	Assemblies Briggs and Stratton 084232-0121- E8	..... 13

## Part Description Abbreviations

Part descriptions in this catalog may include the following abbreviations.

AR. .... as required	HYD. .... hydraulic
ASM. .... assembly	LH. .... left hand
BBC. .... blade brake clutch	NI. .... nylon insert
CARR. .... carriage	NPTF. .... national pipe thread fine
DEG. .... degrees	PFH. .... phillips flat head
EXT. .... external	PPH. .... phillips pan head
FH. .... flat head	PPHTF. .... phillips pan head thread forming
GA. .... gauge	PRH. .... phillips round head
HD. .... heavy-duty	PTH. .... phillips truss head
HF. .... hex flange	PTO. .... power-take-off
HH. .... hex head	RH. .... right hand
HHF. .... hex head flange	ROPS. .... roll-over protection system
HHFTF. .... hex head flange thread forming	SFH. .... slotted fillister head
HJ. .... hex jam	SHH. .... slotted hex head
HLH. .... hex lag head	SHWH. .... slotted hex washer head
HOC. .... height-of-cut	SPH. .... slotted pan head
HSBH. .... hex socket button head	SQH. .... square head
HSFH. .... hex socket flat head	SRH. .... slotted round head
HSH. .... hex socket head	STD. .... standard
HWH. .... hex washer head	TAP. .... self tapping
HWHTF. .... hex washer head thread forming	TTH. .... torx truss head

## Footnotes

- ❶ Not serviced separately



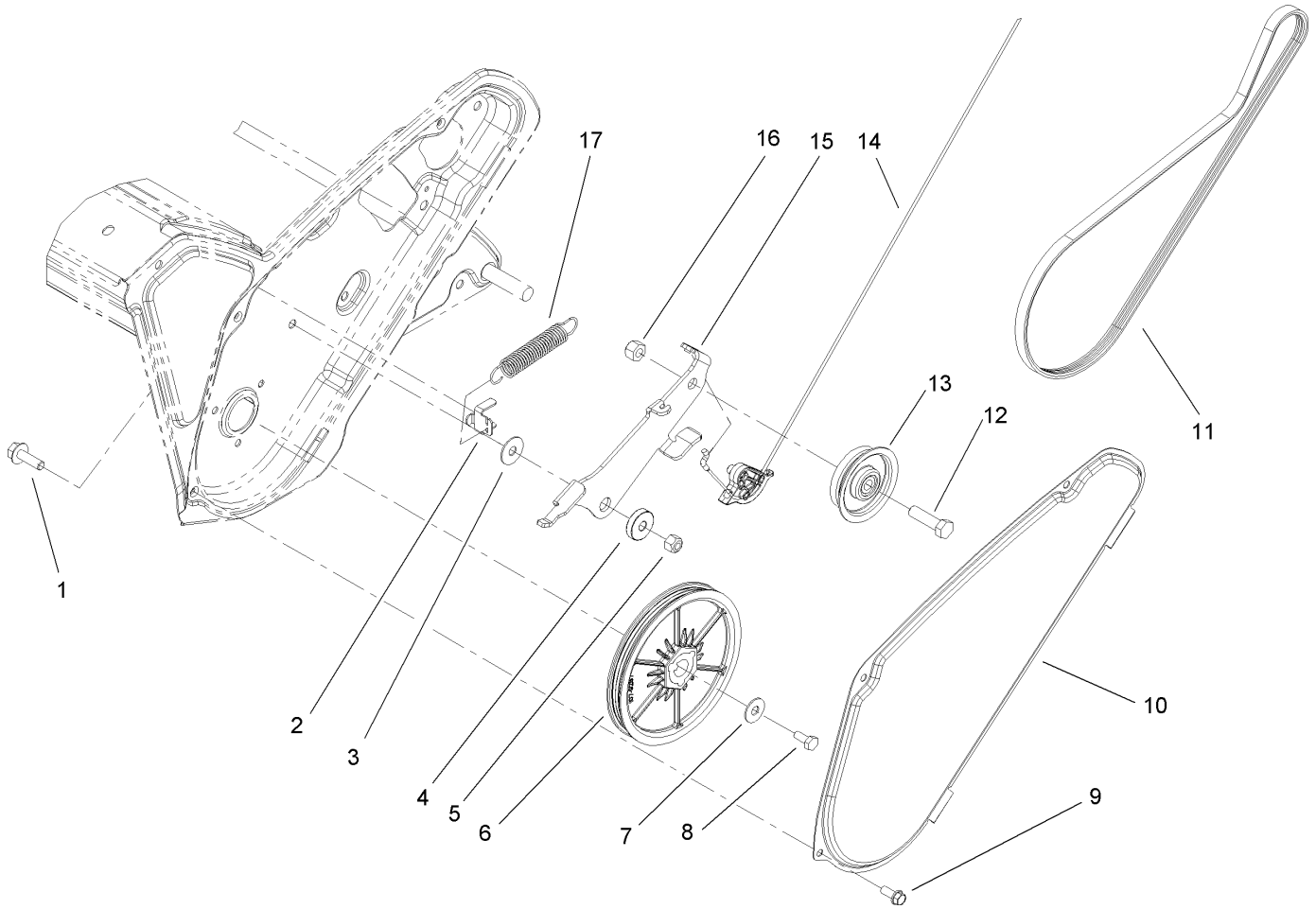

## Rotor Drive Assembly

Ref	Part No.	Qty.	Description
1	3234-29	1	Screw-HHF
2	108-4938	1	Clip-Spring, Brake
3	108-4925	1	Washer
4	108-4916	1	Bushing-Pivot
5	3296-29	1	Nut-Lock, NI
6	107-9287	1	Rotor Pulley ASM
7	3290-456	1	Washer-Belleville
8	110-9381	1	Screw-HH
9	32144-85	3	Screw-HWH
10	108-4893-03	1	Cover-Belt
11	108-4921	1	Belt-Drive
12	323-29	1	Screw-HH
13	114-3785	1	Pulley-Idler
14	94-9949	1	Cable-Clutch
15	114-3782	1	Arm-Idler
16	32152-2	1	Nut-Lock, Cone
17	114-3788	1	Spring-Extension

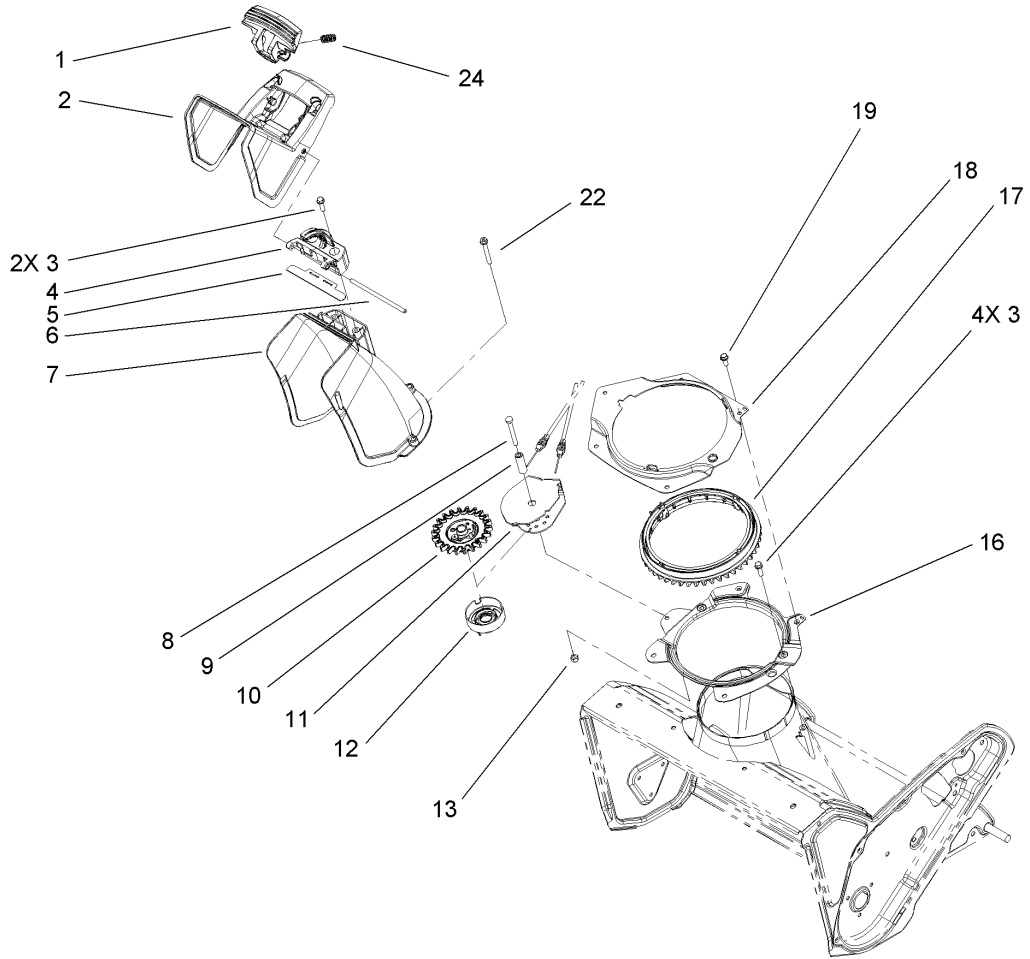
### Chute Assembly

Ref	Part No.	Qty.	Description
1	108-4941	1	Trigger-Deflector
2	108-4940	1	Deflector
3	46-8091	6	Screw-HWH
4	108-4942	1	Hinge-Ratchet, Deflector
5	114-3790	1	Seal-Deflector
6	110-9368	1	Pin-Hinge, Deflector
7	108-4939	1	Chute
8	321-18	1	Screw-HH
9	108-4877	1	Spacer-Sleeve, Pinion
10	108-4875	1	Pinion-Gear
11	108-4900-03	1	Bracket-Pinion
12	114-3792	1	Retainer-Cable
13	3296-42	1	Nut-Lock, NI
16	108-4883-03	1	Ring-Support, Chute
17	108-4882	1	Ring-Chute, Gear
18	108-4874-03	1	Retainer-Ring, Chute
19	32144-85	2	Screw-HWH
22	108-4946	3	Screw-Plastite
24	110-9360	2	Spring-Compression

## Rotor Assembly

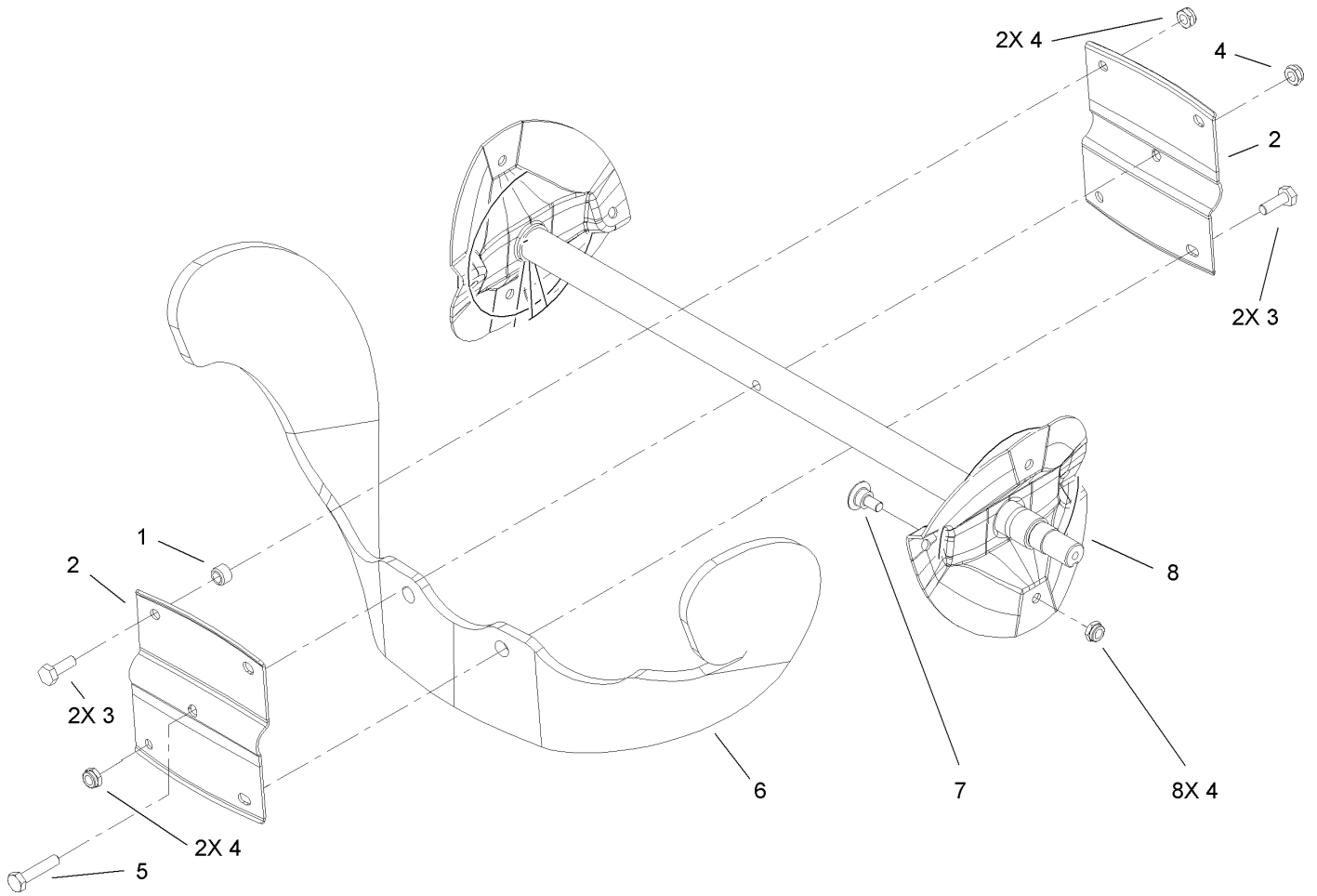
Ref	Part No.	Qty.	Description
1	55-9370	4	Spacer-Blade, Rotor
2	66-6600-03	2	Half-Rotor
3	321-4	4	Screw-HH
4	3296-56	13	Nut-Lock, NI
5	321-8	1	Screw-HH
6	99-9313	2	Blade-Rotor
7	84-1971	8	Screw
8	108-4894-03	1	Rotor

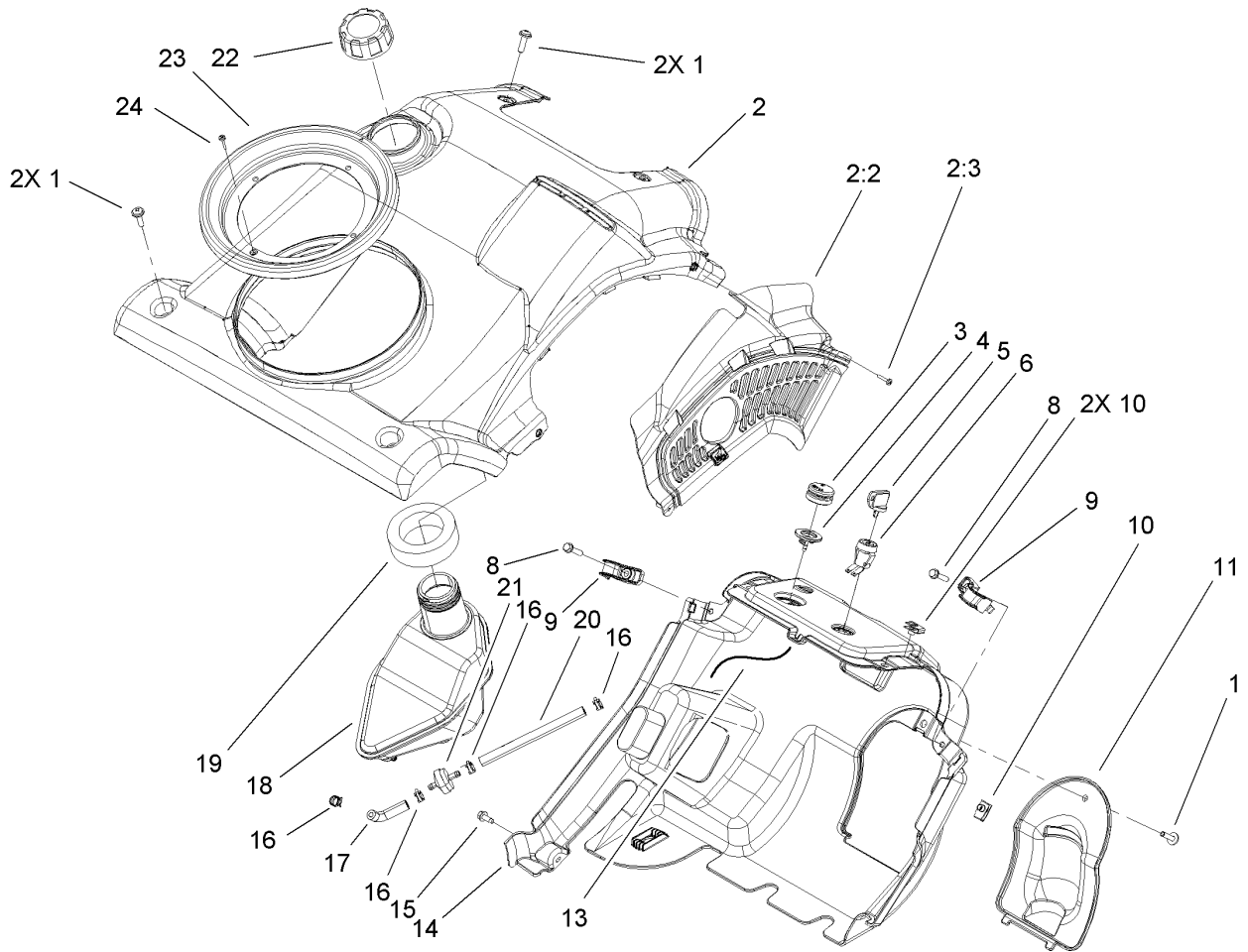

## Shroud and Control Panel Assembly

Ref	Part No.	Qty.	Description
1	110-9361	5	Screw-PPH, Sems
2	114-3756	1	Shroud ASM
2:2	114-3793	1	Baffle-Heat, 2-Cycle
2:3	94-4496	2	Screw-PPH
3	66-7460	1	Bulb-Primer
4	44-2750	1	Body-Primer
5	63-8360	1	Key-Ignition
6	40-5940	1	Switch
8	46-8092	2	Screw-Plastite
9	108-4947	2	Clip-Shroud
10	107069	3	Clip
11	108-4896	1	Panel-Access, Carburetor
13	114-3767	1	Hose-Primer
14	114-3752	1	Shroud-Lower
15	32144-85	1	Screw-HWH
16	2412-98	4	Clamp
17	114-3765	1	Hose-Fuel
18	108-4880	1	Tank-Gas
19	114-3773	1	Seal-Tank
20	114-3766	1	Hose-Fuel
21	56-6360	1	Filter-Fuel
22	104-4133	1	Gas Cap ASM
23	114-3772	1	Seal-Ring, Chute
24	94-4496	1	Screw-PPH





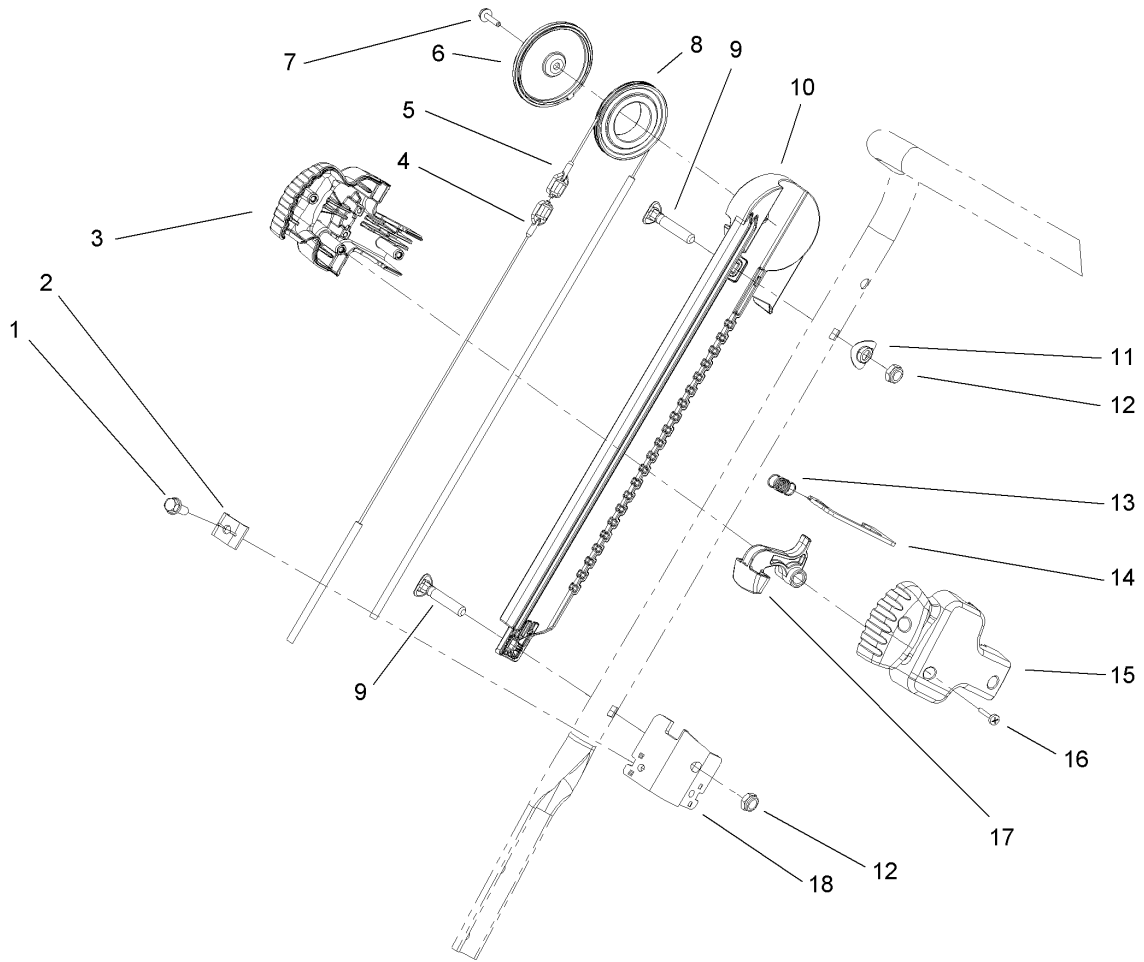

### Quick Turn Assembly

Ref	Part No.	Qty.	Description
1	32144-85	2	Screw-HWH
2	106-7297	2	Clamp-Cable
3	108-4912	1	Handle-Slider, RH
4	108-4897	1	Cable-Chute, Short
5	108-4898	1	Cable-Chute, Long
6	108-4931	1	Cover-Pulley
7	98-1375	1	Screw-HWH
8	108-4907	1	Pulley-Slider
9	107-3018	2	Screw-Handle
10	108-4899	1	Track-Slider
11	107-3844	1	Washer
12	3296-47	2	Nut-Lock, NI
13	108-4914	1	Spring
14	108-4908	1	Plate-Lock, Chute
15	108-4911	1	Handle-Slider, LH
16	94-4496	3	Screw-PPH
17	108-4913	1	Trigger
18	108-4909	1	Bracket-Cable

--	--	--	--

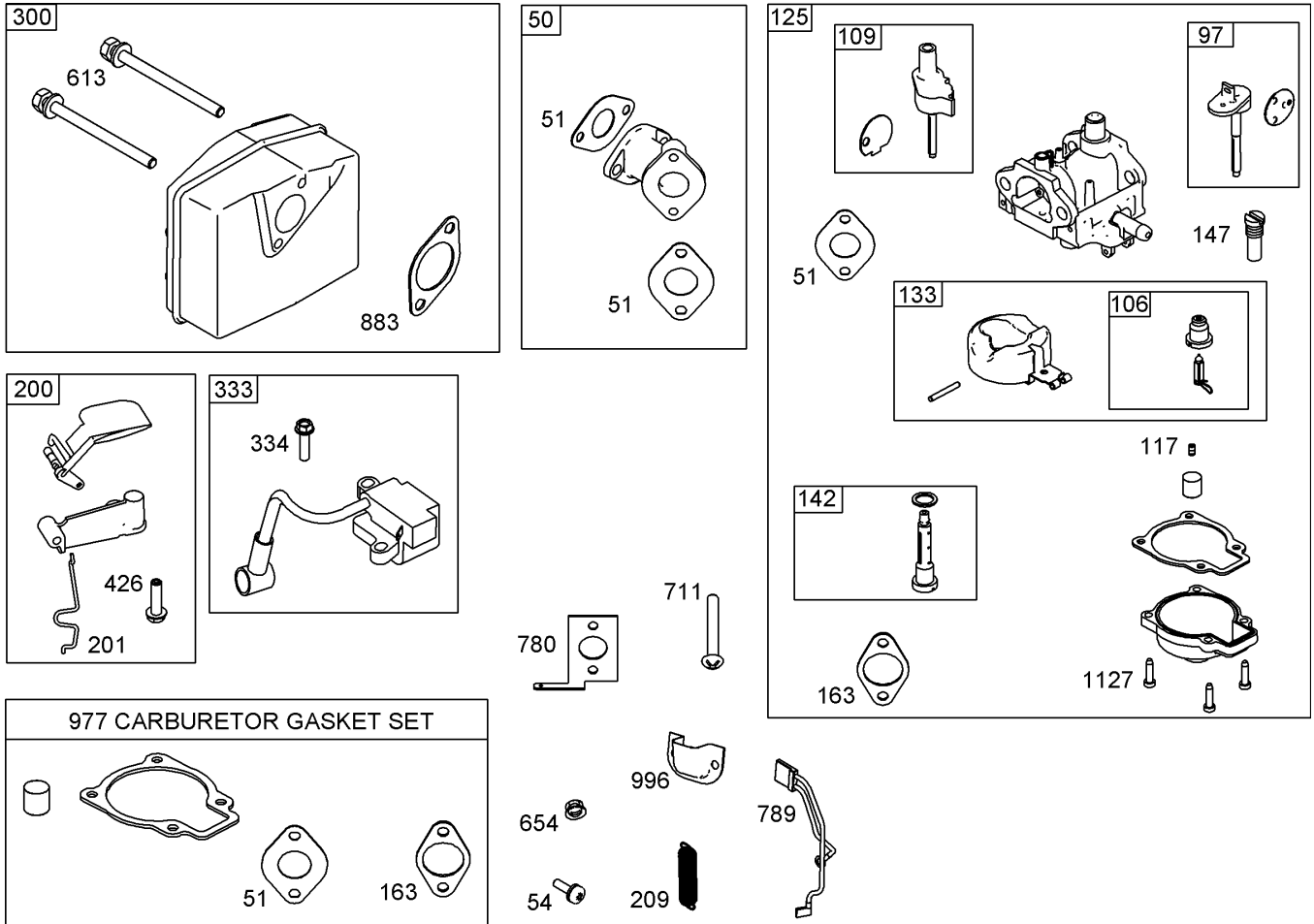



## Muffler, Carburetor and Intake Manifold Assembly Briggs and Stratton 084232-0121-E8

Ref	Part No.	Qty.	Description
50	801232	1	Manifold-Intake
51	801224	1	Gasket-Intake
54	801230	1	Screw (Intake Manifold)
97	801306	1	Shaft-Throttle
106	801317	1	Seat-Inlet
109	801307	1	Shaft-Choke
117	801310	1	Jet-Main (Standard)
125	801233	1	Carburetor
133	801316	1	Float-Carburetor
142	801313	1	Nozzle-Carburetor
147	801308	1	Jet-Pilot
163	801227	1	Gasket-Cleaner, Air
200	801289	1	Blade-Governor
201	801225	1	Link-Vane, Air
209	801223	1	Spring-Governor
300	801250	1	Muffler
333	801268	1	Armature-Magneto
334	801267	1	Screw (Magneto Armature)
426	801231	1	Screw (Governor Blade)
613	801251	1	Screw (Muffler)
654	801324	1	Nut (Intake Manifold) (Used Before Code Date 05042800)
711	801229	1	Screw (Carburetor Shield)
780	801228	1	Anchor-Spring

Ref	Part No.	Qty.	Description
789	801253	1	Wire ASM
883	801252	1	Gasket-Exhaust
977	801312	1	Gasket Set-Carburetor
996	801226	1	Shield-Carburetor
1127	801318	1	Screw (Float Bowl)

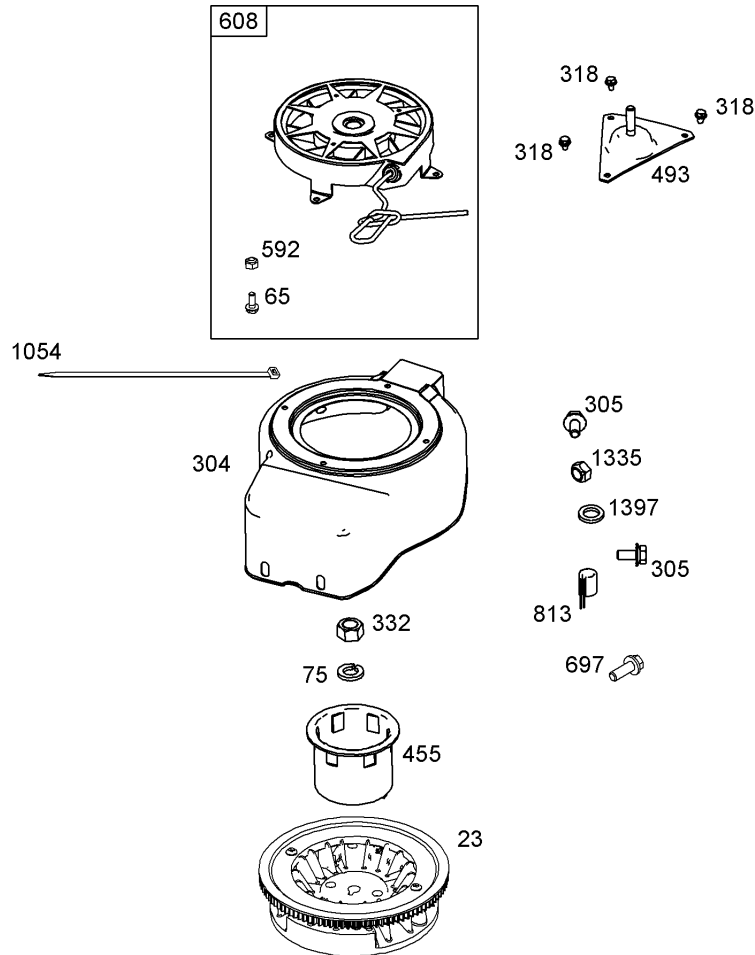

## Flywheel, Blower Housing and Starter Assemblies Briggs and Stratton 084232-0121-E8

Ref	Part No.	Qty.	Description
23	801246	1	Flywheel
65	801243	1	Screw (Rewind Starter)
75	801237	1	Washer (Flywheel)
304	801257	1	Housing-Blower
305	801239	1	Screw (Blower Housing)
318	801241	1	Screw (Mounting Bracket)
332	801238	1	Nut (Flywheel)
455	801235	1	Cup-Flywheel
493	801240	1	Bracket-Mounting
592	801244	1	Nut (Rewind Starter)
608	801242	1	Starter-Rewind
697	801248	1	Screw (Starter Motor)
813	801249	1	Clamp
1054	861206	1	Tie-Cable
1335	801269	1	Nut (Blower Housing)
1397	801270	1	Washer (Blower Housing)

## NOTES

# NOTES

