



Workman[®] 3300-D with Bed

Model No. 07362TC - 270000701 and up.

Parts Catalog

Ordering Replacement Parts

To order replacement parts, please supply the part number, the quantity, and the description of each part desired.

Understanding Reference Numbers

Each Identified part in an illustration has a reference number. The reference number for a part also appears in the parts list, along with other information about the part.

This catalog uses two special reference number formats, one to indicate parts in a service assembly and another to indicate the quantity of a given part in an illustration.

Service Assembly Reference Numbers

Parts in service assemblies have reference numbers in the form a:b. The a represents the reference number of the entire service assembly and the b represents a sequential number unique to each part within the service assembly.

For example, a wheel assembly might be identified by reference number 6, the tire by 6:1, the valve by 6:2, and the wheel by 6:3. When you order the assembly identified by reference number 6, you receive all parts identified by reference numbers 6:1, 6:2, and 6:3. However, you may also order any part individually. Reference numbers of this type appear in illustrations and in part lists.

Reference Numbers Indicating Quantity

In an illustration, if a reference number indicates more than one part, the reference number has the form nX y. The n represents the quantity of the part, the X is the multiplication symbol, and the y represents the reference number.

For example, in an illustration, the reference number 2X 37 means that two of the parts identified by reference number 37 are indicated.

Contents

Description	Page	Description	Page
Hood and Bumper Assembly 4	Engine Support Assembly 40
Dash Panel Assembly 5	Transaxle Assembly 41
Steering Assembly 6	Case Assembly Transaxle Assembly No. 105-4180 42
Steering Pump Assembly No. 106-6726 8	Gear Shaft Assembly Transaxle Assembly No. 105-4180 43
Hydraulic Cylinder Assembly No. 106-2262 9	Countershaft Assembly Transaxle Assembly No. 105-4180 44
Brake Accelerator and Clutch Assembly 10	Shift Fork Assembly Transaxle Assembly No. 105-4180 45
Master Cylinder Assembly No. 104-6782 11	Differential Gear Assembly Transaxle Assembly No. 105-4180 46
Hydraulic Brake Assembly 12	Diesel Hydraulic Filter and Relay Assembly 47
Clutch Linkage Assembly 13	Battery Assembly 48
Shroud and Seat Assembly 14	Diesel Fuel Tank and Air Cleaner Assembly 49
LH Seat Assembly 15	Air Cleaner Assembly No. 106-2416 50
RH Seat Assembly 16	Diesel Filter Assembly 51
Roll-Over Protection System Assembly 17	Full Bed and Side Panel Assembly 52
Front Wheel Assembly 18	Cylinder Assembly 53
RH Front Brake Assembly No. 87-9170 19	Crankshaft Assembly 54
LH Front Brake Assembly No. 87-9180 20	Cylinder Head Assembly 55
Console Assembly 21	Injection Pump Assembly 56
Shift Assembly No. 106-7887 23	Camshaft Assembly 57
Front Suspension Assembly 24	Oil Pan Assembly 58
Front Control Arm Assembly 25	Gear Cover Assembly 59
Lift Valve and Hydraulic Assembly 26	Gear Housing Assembly 60
Control Valve Assembly No. 43-1950 28	Water Pump Assembly 61
Hydraulic Cylinder Assembly No. 106-7939 29	Manifold Assembly 62
Hydraulic Pump Assembly No. 106-6649 30	Starter Motor and Alternator Assembly 63
Rear Frame Assembly 31	Starter Motor Assembly No. 110-2598 64
Rear Axle Assembly 32	Alternator Assembly No. 99-9209 65
LH Rear Brake Assembly No. 93-7126 33	Gasket Assembly 66
RH Rear Brake Assembly No. 93-7125 34	Attachments and Accessories List 67
Driveshaft Assembly No. 98-2918 35		
Radiator and Hydraulic Pump Assembly 36		
Fan and Hydraulic Pump Drive Assembly 37		
Tail Light and Fender Assembly 38		
Diesel Engine Assembly 39		

Part Description Abbreviations

Part descriptions in this catalog may include the following abbreviations.

AR.	as required	HYD.	hydraulic
ASM.	assembly	LH.	left hand
BBC.	blade brake clutch	NI.	nylon insert
CARR.	carriage	NPTF.	national pipe thread fine
DEG.	degrees	PFH.	phillips flat head
EXT.	external	PPH.	phillips pan head
FH.	flat head	PPHTF.	phillips pan head thread forming
GA.	gauge	PRH.	phillips round head
HD.	heavy-duty	PTH.	phillips truss head
HF.	hex flange	PTO.	power-take-off
HH.	hex head	RH.	right hand
HHF.	hex head flange	ROPS.	roll-over protection system
HHFTF.	hex head flange thread forming	SFH.	slotted fillister head
HJ.	hex jam	SHH.	slotted hex head
HLH.	hex lag head	SHWH.	slotted hex washer head
HOC.	height-of-cut	SPH.	slotted pan head
HSBH.	hex socket button head	SQH.	square head
HSFH.	hex socket flat head	SRH.	slotted round head
HSH.	hex socket head	STD.	standard
HWH.	hex washer head	TAP.	self tapping
HWHTF.	hex washer head thread forming	TTH.	torx truss head

Footnotes

- ❶ Not serviced separately

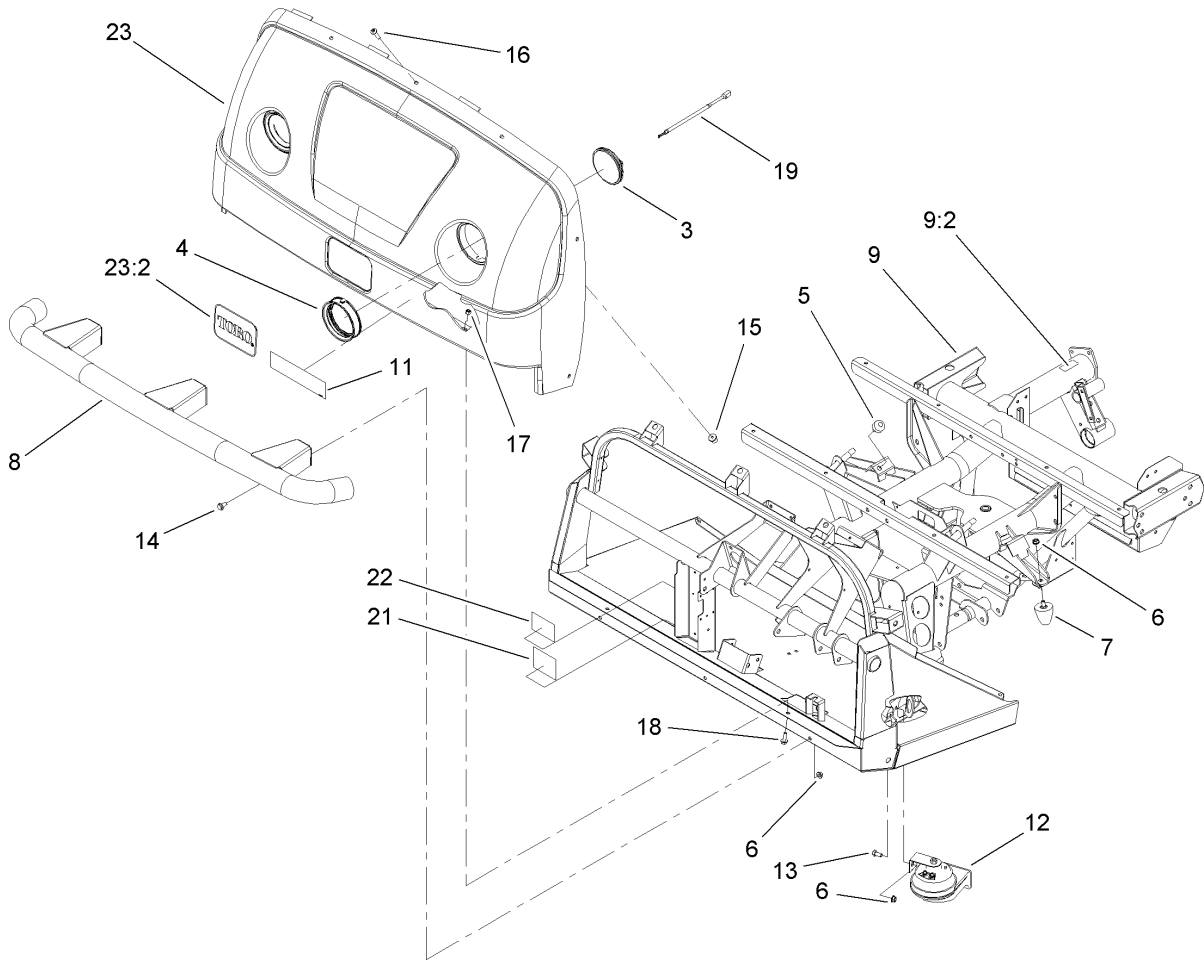

Hood and Bumper Assembly

Ref	Part No.	Qty.	Description
3	99-7310	2	Headlight
4	99-7311	2	Mount-Headlight
5	87-2440	2	Bumper-Rubber
6	3290-357	9	Nut-HHF, Whiz
7	26-0071	2	Snubber-Rubber
8	106-2369-03	1	Bumper ASM
9	106-7884	1	Operator Frame ASM
9:2	93-7814	1	Decal-Danger
11	106-2395	1	Decal
12	110-2594	1	Horn ASM
13	323-4	1	Screw-HH
14	3234-1	6	Screw-HHF
15	106-7883	7	Nut-Well
16	106-7922	7	Screw-PTH
17	3296-29	2	Nut-Lock, NI
18	3234-29	2	Screw-HHF
19	106-2401	2	Harness-Headlight
21	106-7894	1	Decal-Block, Fuse
22	106-7896	1	Decal-Rating, Load
23	107-7979	1	Front Hood ASM
23:2	62-5550	1	Decal

--	--	--	--

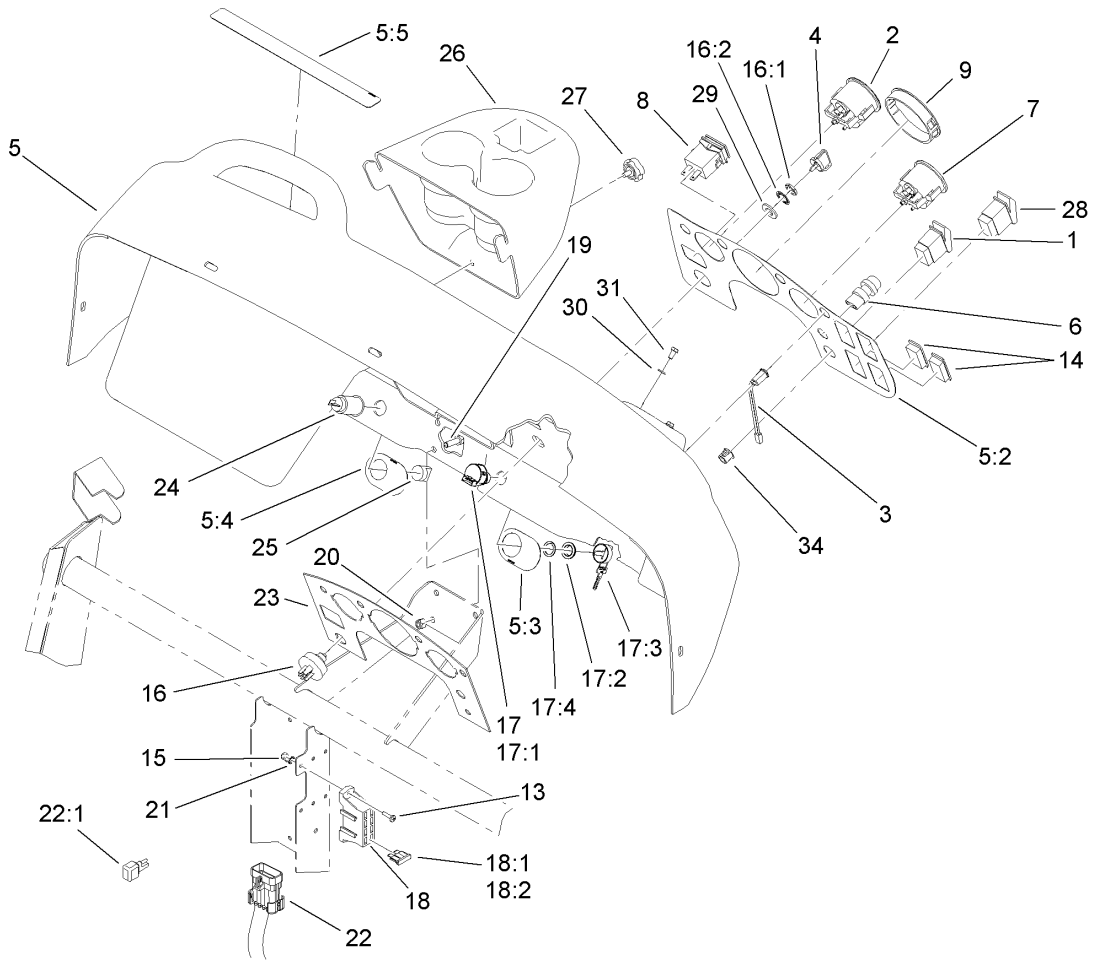

Dash Panel Assembly

Ref	Part No.	Qty.	Description
1	95-8999	1	Switch
2	106-2406	1	Gauge-Temperature
3	95-7652	4	Light-Indicator
4	63-8360	2	Key-Ignition
5	112-3040	1	Dash ASM
5:2	106-2352	1	Decal-Dash
5:3	106-2355	1	Decal-Switch, Supervisor
5:4	106-2353	1	Decal-Powerpoint
5:5	110-2599	1	Decal-Warning, Dash
6	18-2830	1	Button-Horn
7	106-2405	1	Gauge-Fuel
8	94-4208	1	Hourmeter
9	106-2359	1	Plug-Cap
13	32105-13	2	Screw-SHH
14	99-7420	2	Plug-Hole
15	3296-2	2	Nut-Lock
16	27-2360	1	Switch-Key
16:1	218-446	1	Nut-Hex
16:2	218-447	1	Washer-Lock
17	110-2580	1	Switch-Key, Supervisor
17:1		1	Switch-Key
17:2	108-8660	1	Nut-Mounting
17:3	110-5221	1	Set-Key, Supervisor
17:4	108-8659	1	Washer-Backup

Ref	Part No.	Qty.	Description
18	112-3526	1	Harness-Wire, Front
18:1	218-578	2	Fuse-10 Amp
18:2	109355	2	Fuse-15 Amp
19	322-3	3	Screw-HH
20	3296-29	3	Nut-Lock, NI
21	3255-10	1	Washer-Lock / EXT
22	110-2529	1	Harness-Wire, Rear Diesel
22:1	100-4918	2	Diode
23	106-2360-03	1	Plate-Dash
24	99-7411	1	Point-Power
25	99-7416	1	Cap
26	106-2358	1	Cover-Reservoir
27	105-1406	1	Knob
28	106-2027	1	Switch-Intermittent
29	9202624	1	Washer
30	33093-00	2	Washer-Flat
31	33113-012	2	Screw-HH
34	104-9368	1	Plug-Dome

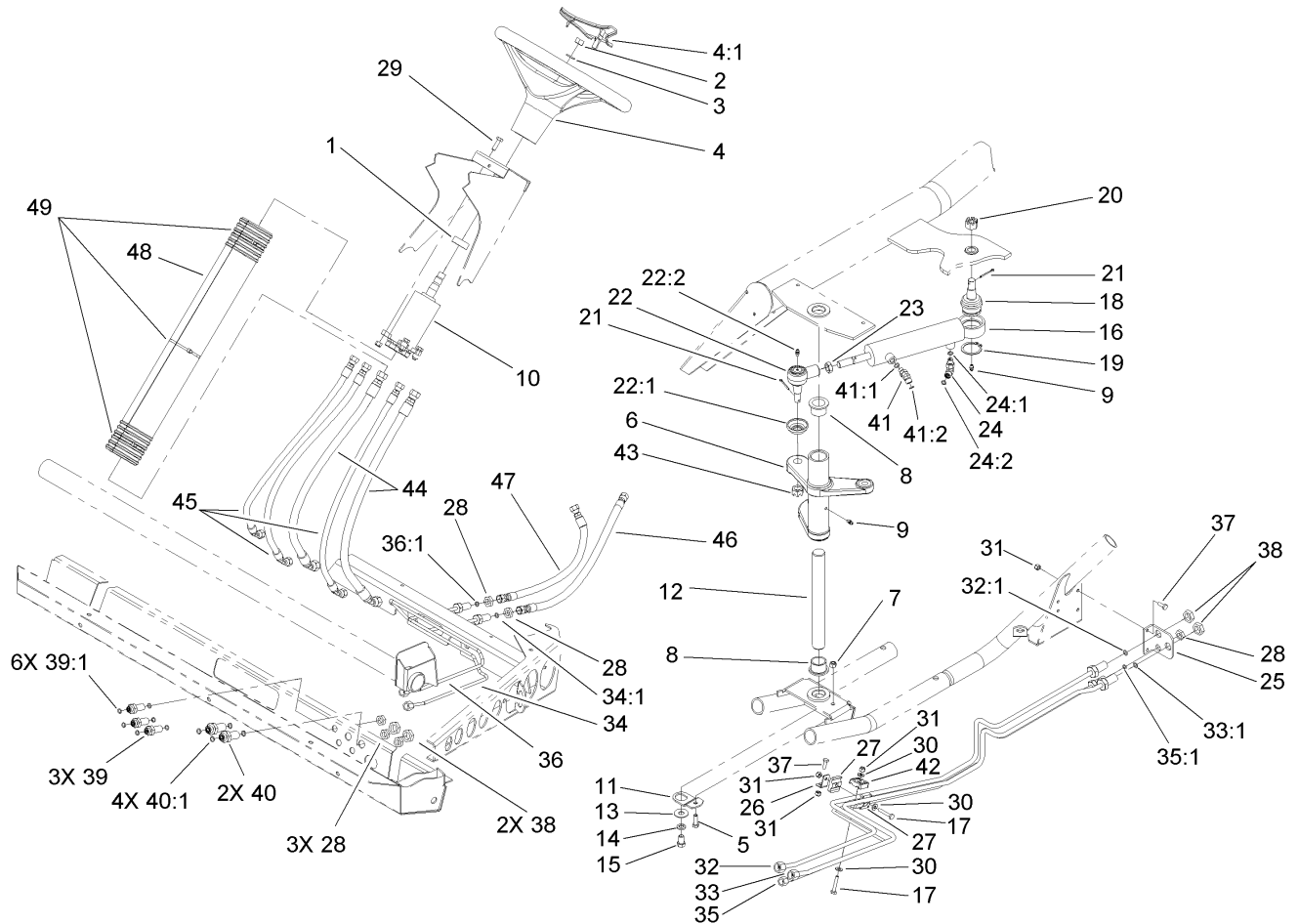

Steering Assembly

Ref	Part No.	Qty.	Description
1	21-9260	1	Cover-Dust
2	3296-33	1	Nut-Lock, NI
3	3256-27	1	Washer-Flat
4	98-1471	1	Wheel-Steering
4:1	98-1468	1	Cover-Wheel, Steering
5	322-5	1	Screw-HH
6	106-2536	1	Arm-Pitman
7	3296-29	1	Nut-Lock, NI
8	94-1291	2	Bushing
9	302-5	2	Fitting-Grease
10	106-6726	1	Steering Pump ASM
11	106-2287	1	Plate
12	106-2271	1	Shaft-Pivot
13	3256-5	1	Washer-Flat
14	3253-6	1	Washer-Lock
15	324-2	1	Screw-HH
16	106-2262	1	Cylinder-HYD
17	321-8	2	Screw-HH
18	106-6774	1	Joint-Ball
19	32151-104	1	Ring-Retaining, External
20	32136-14	1	Nut-SHH
21	3272-12	2	Pin-Cotter
22	106-6898	1	Joint-Ball
22:1	106-6896	1	Seal

Ref	Part No.	Qty.	Description
22:2	302-5	1	Fitting-Grease
23	3220-11	1	Nut-Jam
24	340-132	1	Fitting-HYD, 90 DEG
24:1	237-78	1	O-Ring
24:2	237-21	1	O-Ring
25	106-7801-03	1	Bracket-Line, Steering
26	106-7807	1	Bracket-Line, Steering
27	106-7839	2	Clamp-Tube
28	340-78	6	Nut-Lock, Bulkhead
29	33114-020	4	Screw-HH
30	3256-22	3	Washer-Flat
31	3296-42	5	Nut-Lock, NI
32	108-6938	1	Tube-HYD
32:1	237-22	1	O-Ring
33	108-6939	1	Tube-HYD
33:1	237-22	1	O-Ring
34	106-7804	1	Tube-HYD
34:1	237-21	1	O-Ring
35	108-6940	1	Tube-HYD
35:1	237-21	1	O-Ring
36	106-7806	1	Tube-HYD
36:1	237-21	1	O-Ring
37	321-4	3	Screw-HH
38	340-70	4	Nut-Lock

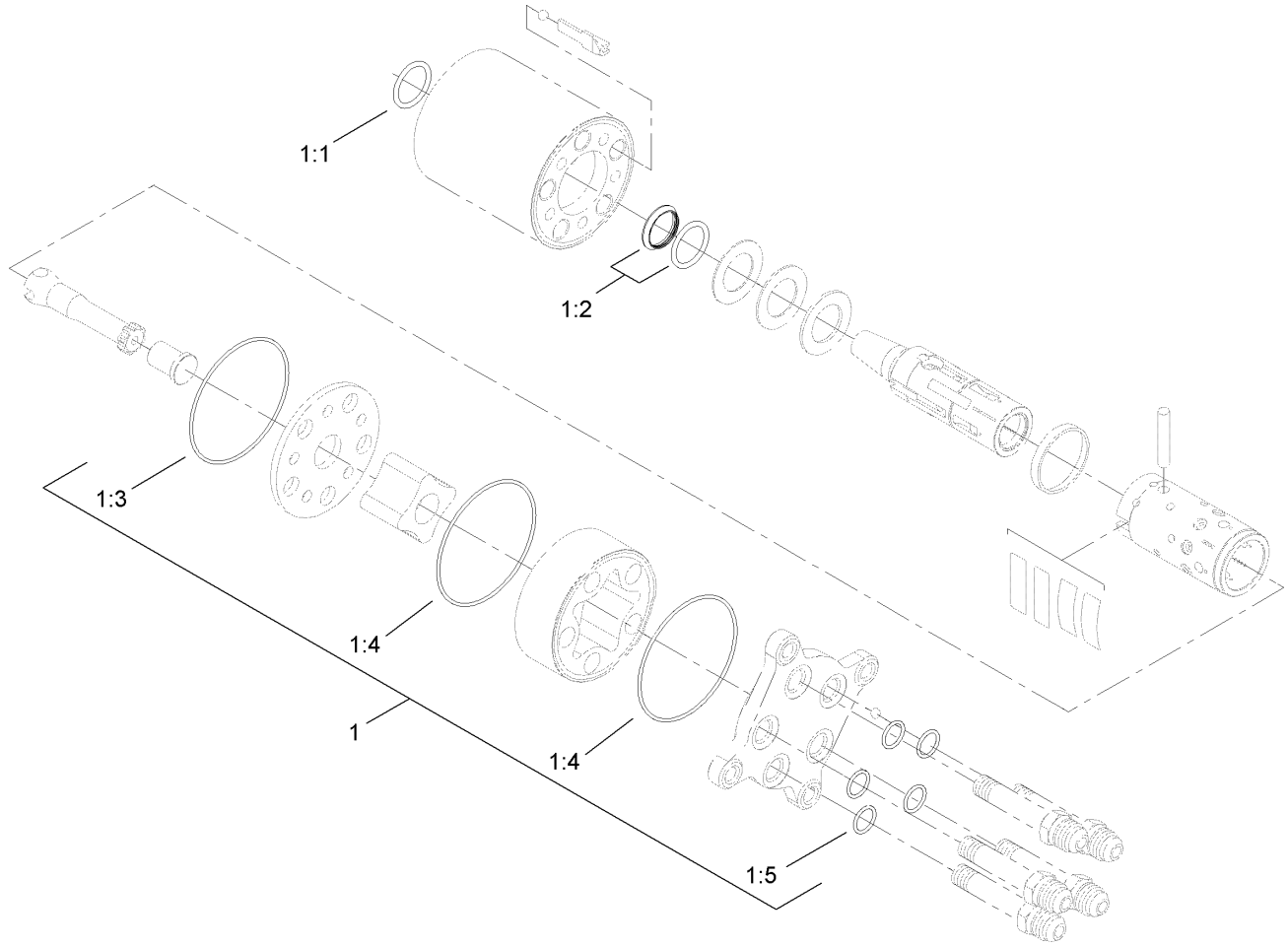

Steering Pump Assembly No. 106-6726

Ref	Part No.	Qty.	Description
1	106-6716	1	Seal Kit
● 1:1		1	Ring-Seal, Dust
● 1:2		1	Seal-Shaft
● 1:3		1	O-Ring
● 1:4		2	O-Ring
● 1:5		5	O-Ring

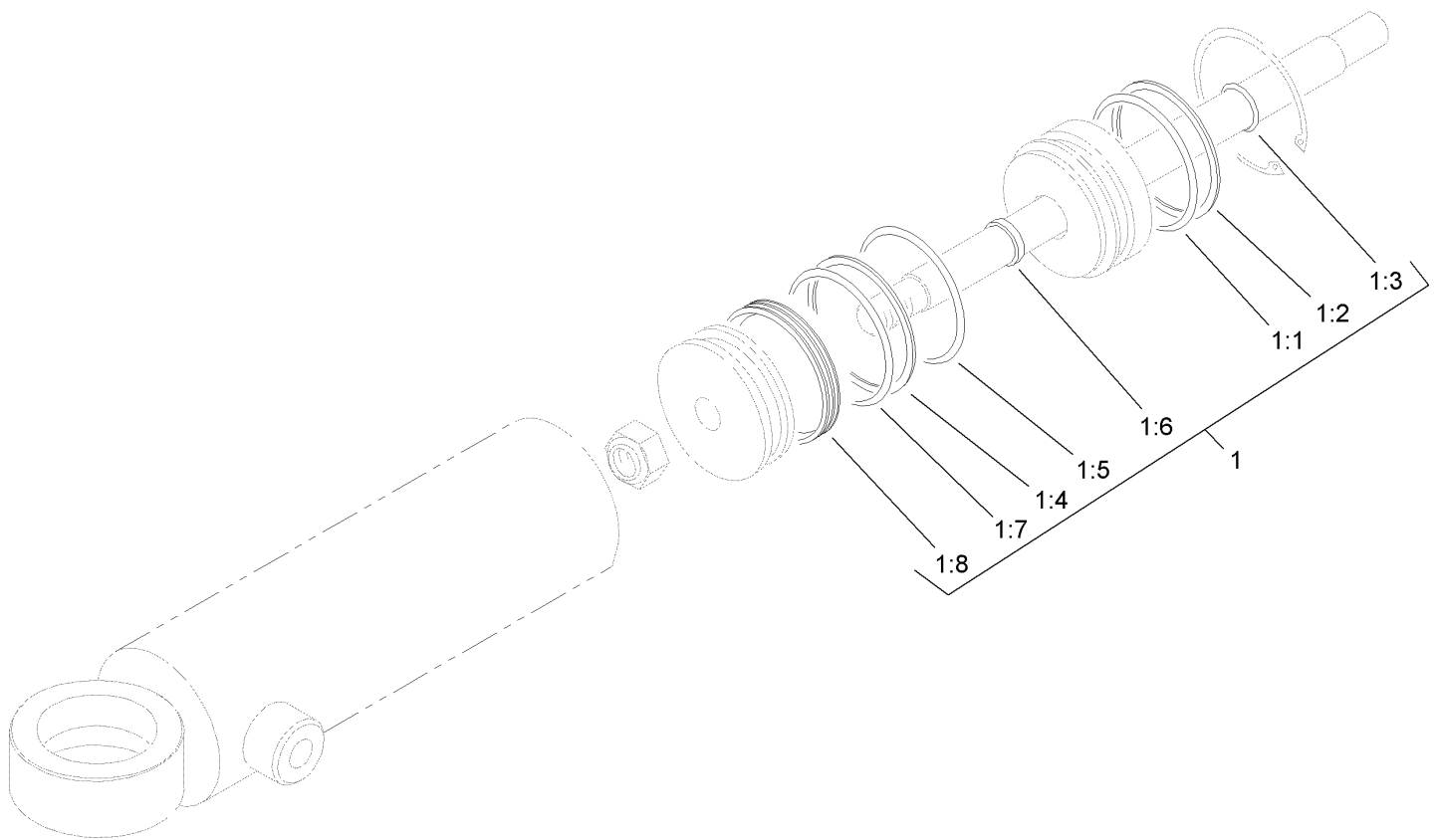

Hydraulic Cylinder Assembly No. 106-2262

Ref	Part No.	Qty.	Description
1	106-6712	1	Seal Kit
● 1:1		1	O-Ring
● 1:2		1	O-Ring
● 1:3		1	Wiper
● 1:4		1	O-Ring
● 1:5		1	Back-Up
● 1:6		1	Seal
● 1:7		1	Seal
● 1:8		1	Ring-Wear

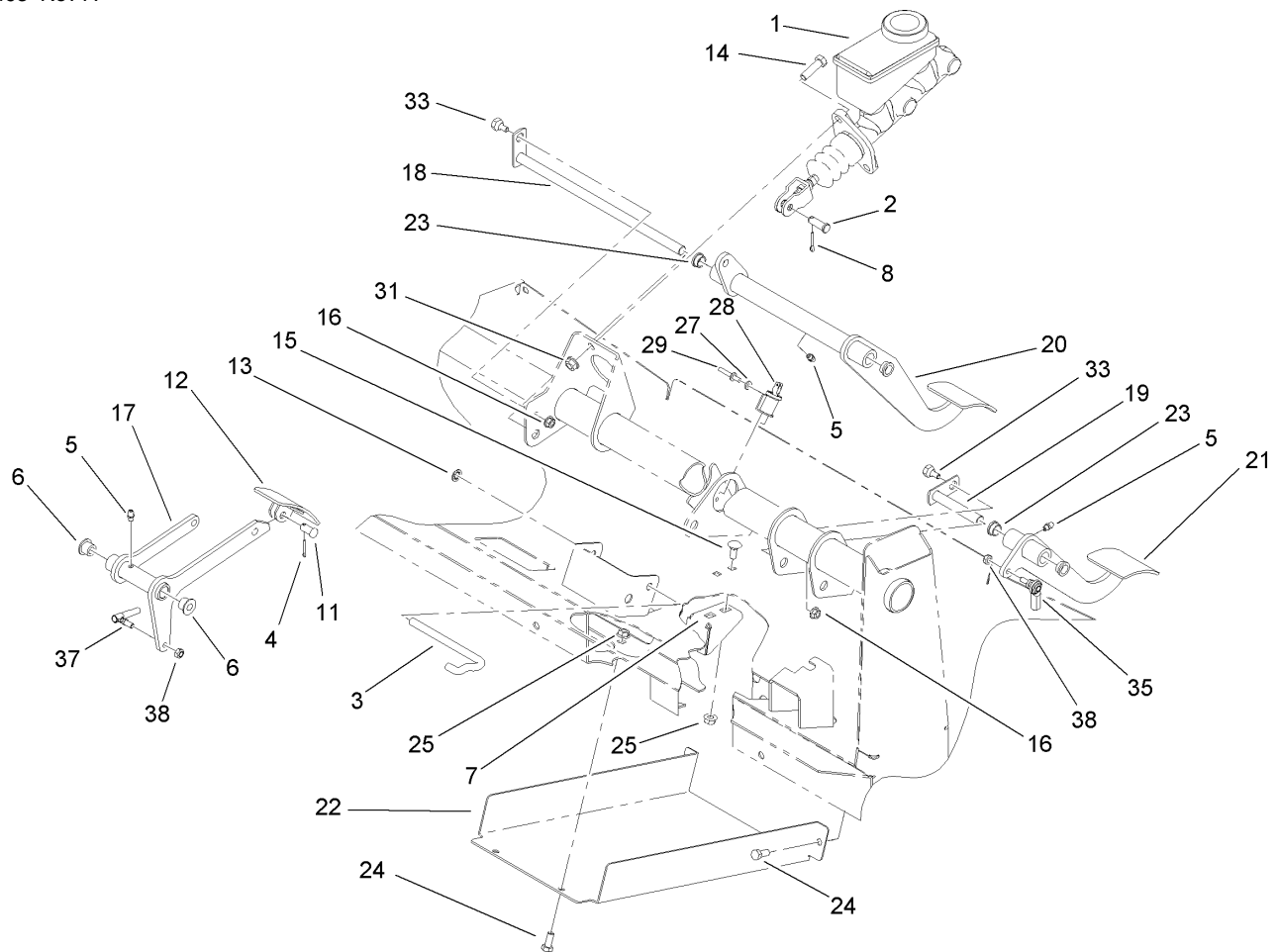

Brake Accelerator and Clutch Assembly

Ref	Part No.	Qty.	Description
1	104-6782	1	Cylinder-Master
2	283-2	1	Pin-Clevis
3	87-2880	1	Shaft-Pedal, Accelerator
4	3272-6	1	Pin-Cotter
5	302-5	3	Fitting-Grease
6	256-259	2	Bushing-Flange
7	106-2421	1	Bracket-Mount, Cable
8	3272-10	1	Pin-Cotter
11	283-85	1	Pin-Clevis
12	93-8969-03	1	Pedal
13	32151-56	1	Ring-Retaining, External
14	323-7	2	Screw-HH
15	3230-1	2	Bolt-CARR
16	32128-33	2	Nut-HF
17	106-2471-03	1	Arm-Pedal, Accelerator
18	106-2475	1	Brake Shaft ASM
19	106-2476	1	Clutch Shaft ASM
20	106-2461-03	1	Brake Pedal ASM
21	106-2457-03	1	Clutch Pedal ASM
22	106-2427-03	1	Cover
23	256-156	4	Bushing-Flange
24	322-3	4	Screw-HH
25	32128-20	6	Nut-HF
27	3256-21	2	Washer-Flat

Ref	Part No.	Qty.	Description
28	95-1653	1	Switch-Pole, Single
29	3290-382	2	Rivet-Pop
31	3290-357	2	Nut-HHF, Whiz
33	63-3410	2	Screw-Shoulder
35	110-2554	1	Rod End-Spherical
37	18-1720	1	Governor Ball Joint ASM
38	3296-13	2	Nut-Lock NI



Master Cylinder Assembly No. 104-6782

Ref	Part No.	Qty.	Description
1	104-6845	1	Reservoir ASM
1:1	92-4112	1	Cap ASM
2	93-8971	2	Seal-Port, Flange
3	92-4103	1	Pin-Stop
4	92-4102	1	Secondary Piston ASM
5	92-4110	1	Clevis
6	21-0360	1	Nut-Hex
7	94-5209	1	Cover-Dust
8	94-5210	1	Rod-Push
9	92-4109	1	Ring-Snap
10	92-4108	1	Retainer-Washer
11	92-4101	1	Primary Piston ASM

--	--	--	--

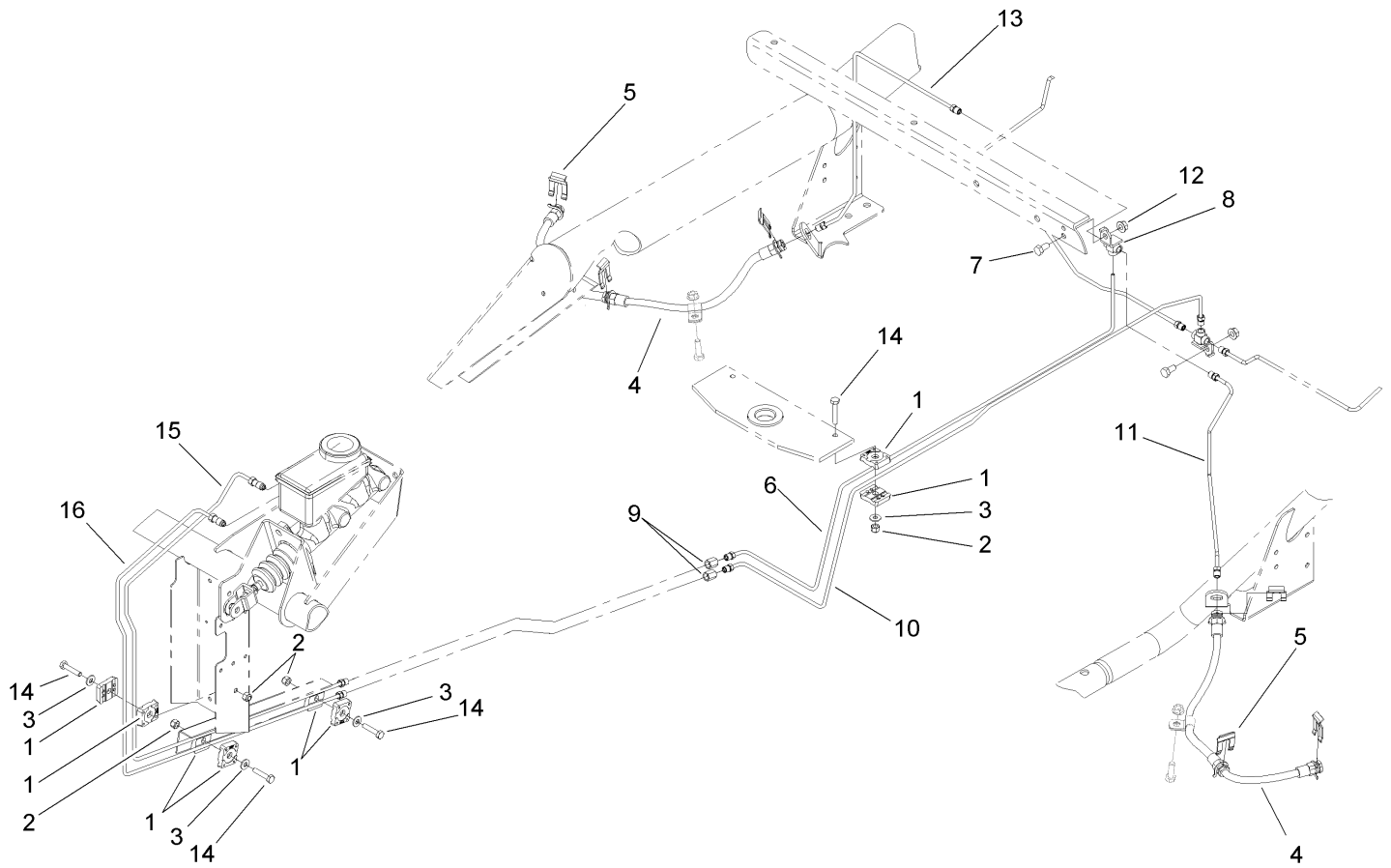

Hydraulic Brake Assembly

Ref	Part No.	Qty.	Description
1	87-7660	8	Clamp-Tube
2	3296-42	4	Nut-Lock, NI
3	3256-22	4	Washer-Flat
4	93-7123	2	Front Brake Hose ASM
5	87-3580	2	Clip-Retainer
6	106-6686	1	Tube ASM
7	322-2	1	Screw-HH
8	87-3560	1	Tee
9	87-3570	2	Union
10	106-6687	1	Tube ASM
11	106-6688	1	Tube ASM
12	32128-20	1	Nut-HF
13	106-6689	1	Tube ASM
14	321-8	4	Screw-HH
15	106-6683	1	Tube ASM
16	106-6684	1	Tube ASM

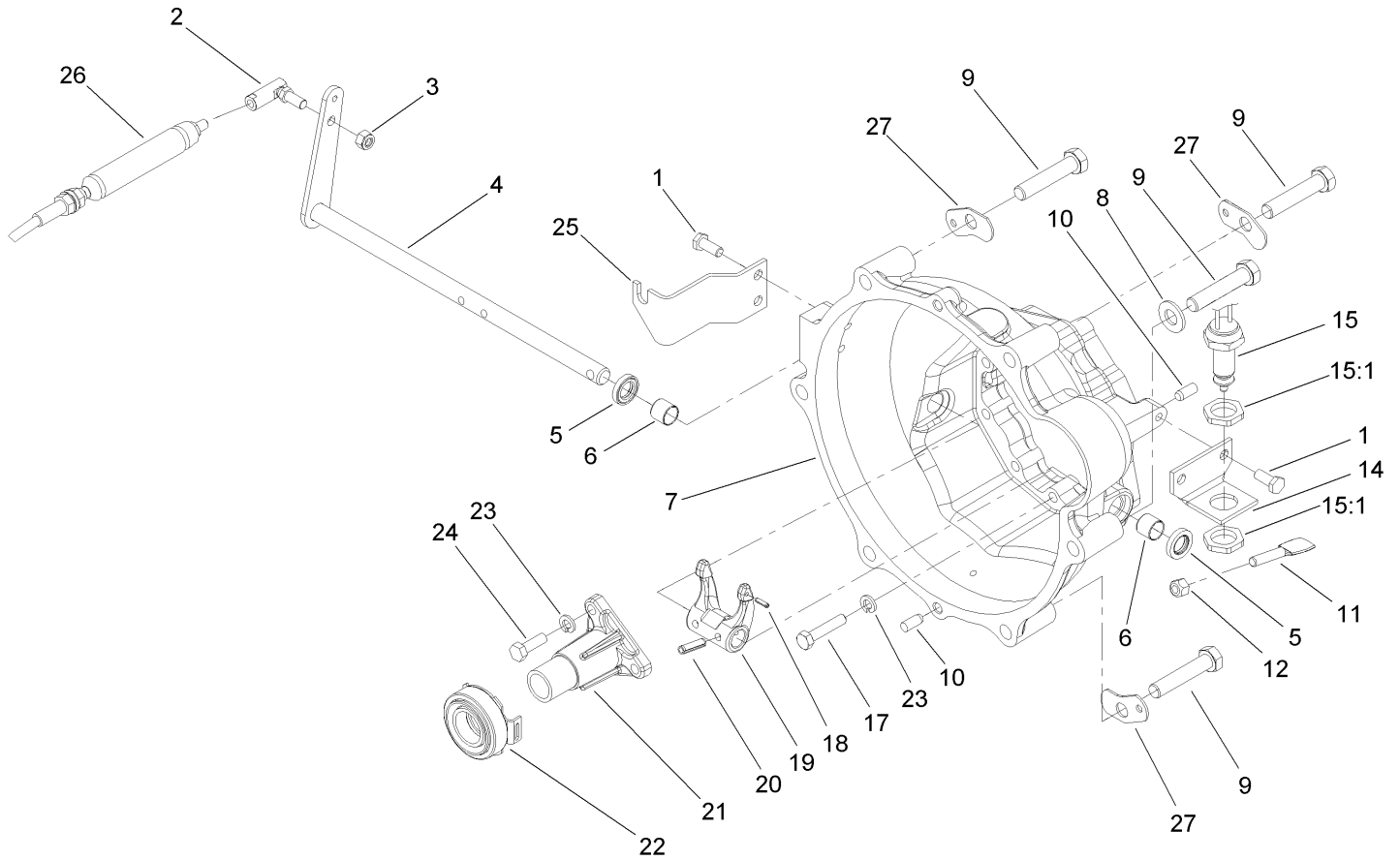

Clutch Linkage Assembly

Ref	Part No.	Qty.	Description
1	33114-020	4	Screw-HH
2	2411-33	1	Balljoint-RH (W/Grommet)
3	3296-4	1	Nut-Lock
4	105-1702	1	Release Shaft ASM
5	87-1920	2	Seal-Oil
6	87-3770	2	Bushing-Housing, Bell
7	104-9249	1	Housing-Bell
8	3256-26	3	Washer-Flat
9	3215-2	6	Screw-HH
10	87-1910	4	Pin-Dowel
11	87-5360	1	Paddle-Clutch, Switch
12	3296-29	1	Nut-Lock, NI
14	87-5350	1	Bracket-Clutch, Switch
15	87-5490	1	Switch-Clutch
15:1	3218-20	2	Nut-Jam
17	33114-040	9	Screw-HH
18	32121-7	1	Pin-Roll, Slotted
19	87-5300	1	Fork-Clutch
20	32121-24	2	Pin-Spring
21	87-5320	1	Release-Guide
22	110-2538	1	Bearing-Release, Clutch
23	3253-4	12	Washer-Lock
24	33114-025	3	Screw-HH
25	112-3116	1	Bracket-Cable, Clutch

Ref	Part No.	Qty.	Description
26	110-2548	1	Cable-Clutch
27	87-6410	3	Bracket-Harness

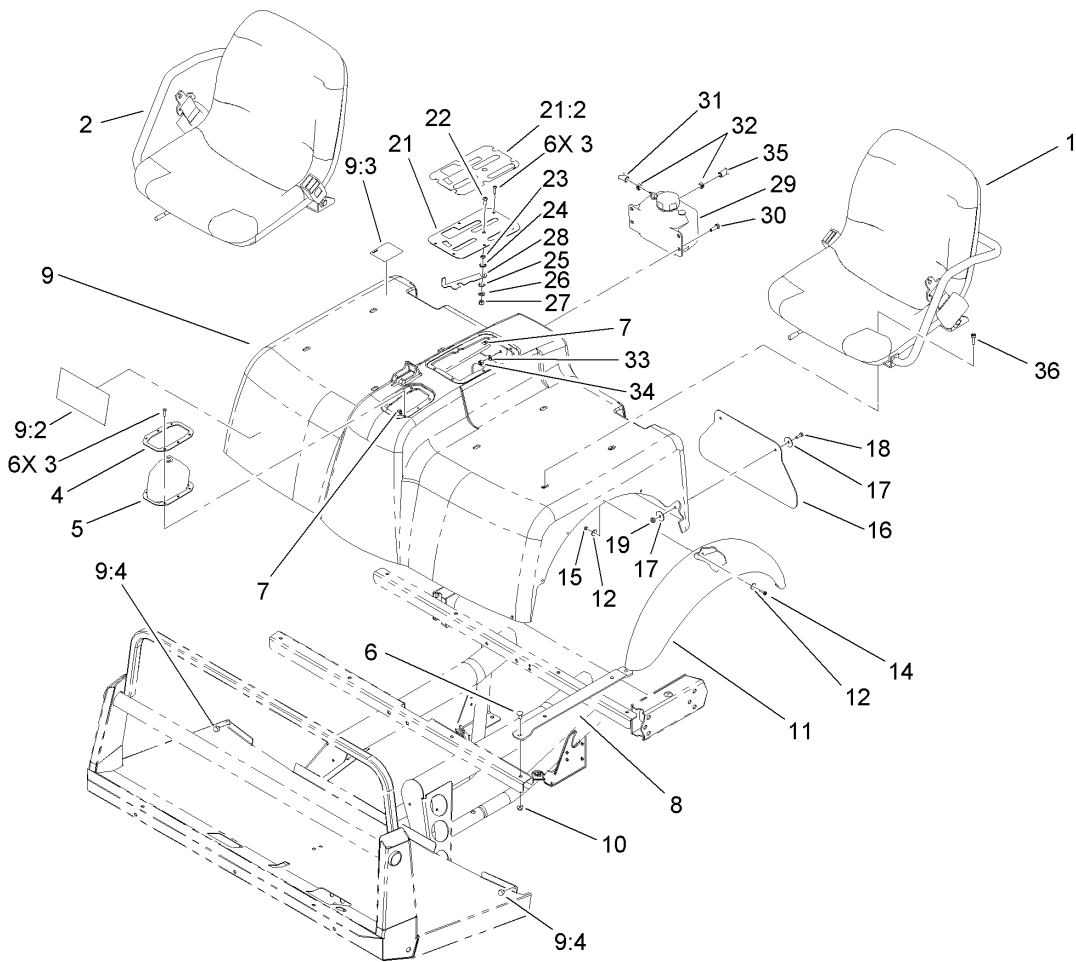

Shroud and Seat Assembly

Ref	Part No.	Qty.	Description
❶		1	LH Seat ASM
❷		1	RH Seat ASM
3	32144-36	12	Screw-PPH
4	87-3760-03	1	Plate-Boot, Shift
5	87-8620	1	Shift Boot ASM
6	3230-1	8	Bolt-CARR
7	106-2388	12	Clip-Fastener
8	107-7957-03	4	Seat Bracket ASM
9	106-2362	1	Seatbase ASM
9:2	106-2384	1	Decal-Reference, Quick
9:3	93-9448	1	Decal-Fuel
9:4	107-8042	2	Bumper-Rubber
10	104-8300	8	Nut-Flange, NI
11	106-2375	2	Fender-Front
12	3256-61	20	Washer-Flat
14	32105-13	10	Screw-SHH
15	3296-2	10	Nut-Lock
16	106-2378	2	Mudflap
17	3256-55	8	Washer-Flat
18	321-4	4	Screw-HH
19	3296-16	4	Nut-Lock, NI
21	106-7886	1	Control Plate ASM
21:2	106-2377	1	Decal-Console
22	3274-55	1	Screw-HSBH

Ref	Part No.	Qty.	Description
23	82-4240	1	Spacer-Bearing
24	94-8196	1	Washer-Nylon
25	3290-221	1	Washer-Spring
26	3256-23	1	Washer-Flat
27	3296-29	1	Nut-Lock, NI
28	106-7984	1	Lever-Detent
29	87-3710	1	Reservoir-Coolant
30	322-5	4	Screw-HH
31	110-4104	1	Hose-Fuel
32	92-2379	2	Clamp-Hose
33	3256-23	4	Washer-Flat
34	3296-29	4	Nut-Lock, NI
35	110-6186	1	Hose-Fuel
36	3274-22	8	Screw-HSH

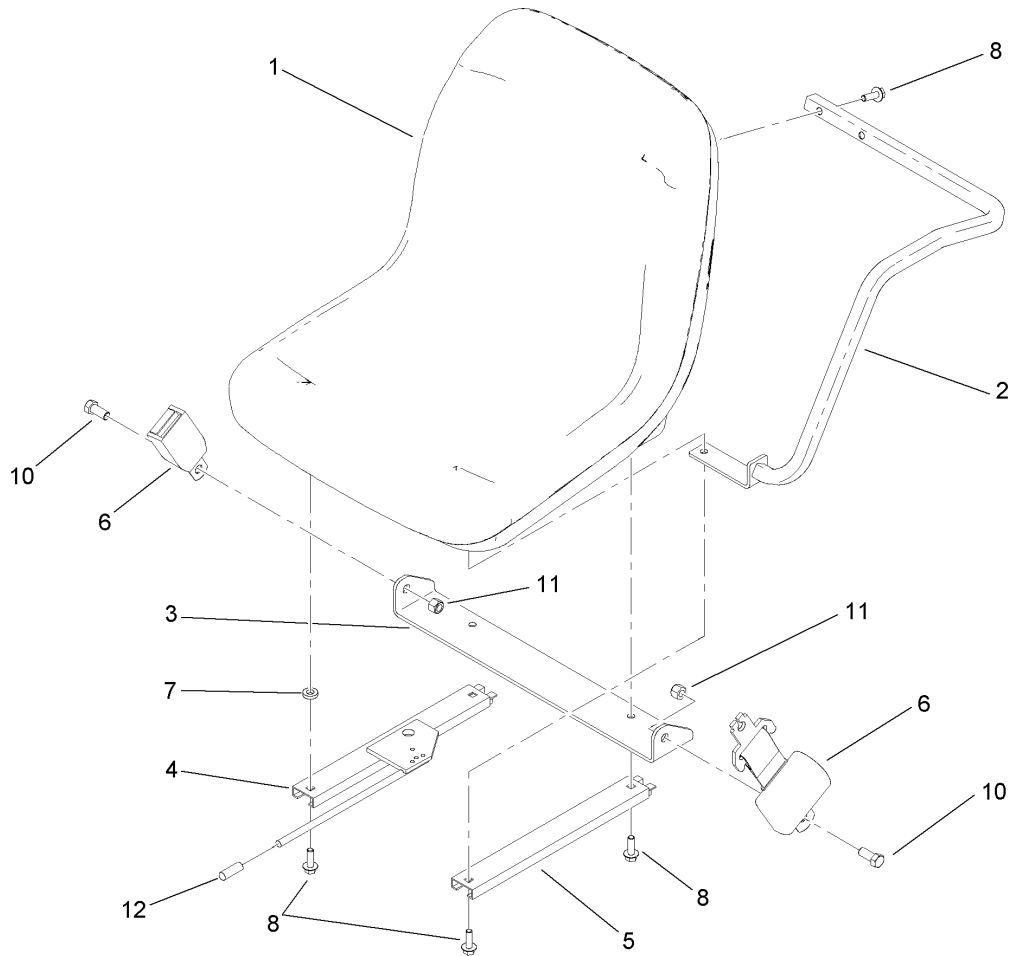

LH Seat Assembly

Ref	Part No.	Qty.	Description
1	112-2923	1	Seat ASM
2	106-7842	1	LH Armrest ASM
3	106-7845	1	Bracket-Belt, Seat
4	106-7847	1	Adjuster-Seat, W/Handle
5	107-7959	1	Adjuster-Slave, 7 Inch
6	106-7848	1	Seat Belt ASM
7	80-7730	1	Spacer
8	3234-29	6	Screw-HHF
10	3212-4	2	Screw-HH
11	3296-7	2	Nut-Lock
12	106-7953	1	Grip-Gray

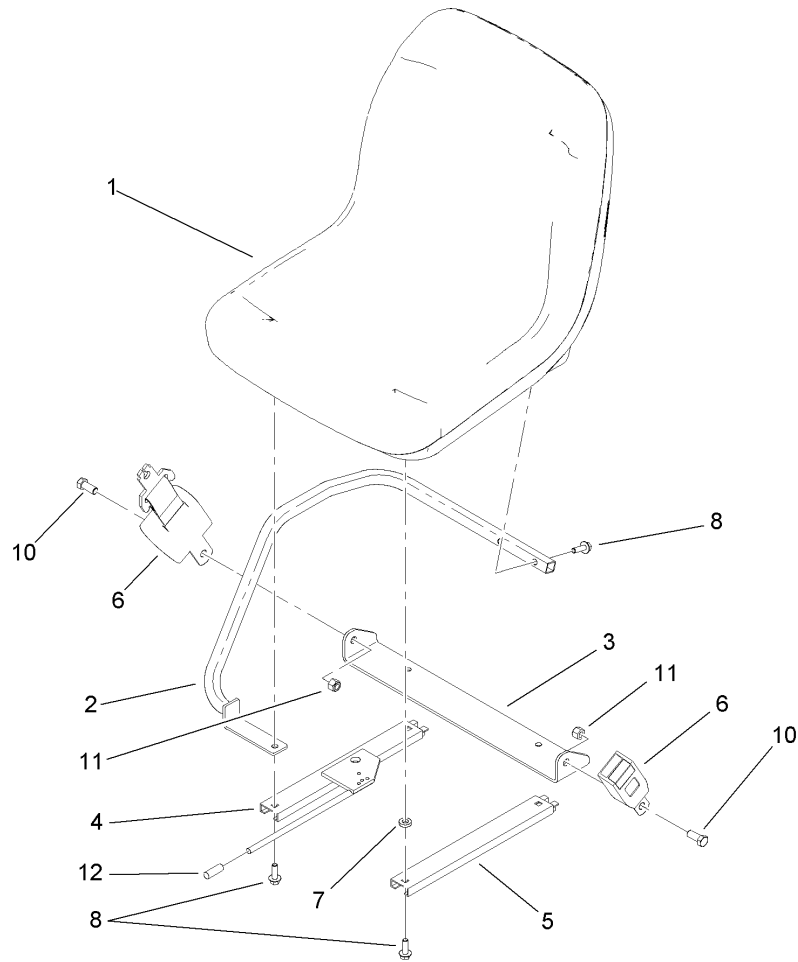

RH Seat Assembly

Ref	Part No.	Qty.	Description
1	112-2923	1	Seat ASM
2	106-7844	1	RH Armrest ASM
3	106-7845	1	Bracket-Belt, Seat
4	106-7847	1	Adjuster-Seat, W/Handle
5	107-7959	1	Adjuster-Slave, 7 Inch
6	106-7848	1	Seat Belt ASM
7	80-7730	1	Spacer
8	3234-29	6	Screw-HHF
10	3212-4	2	Screw-HH
11	3296-7	2	Nut-Lock
12	106-7953	2	Grip-Gray

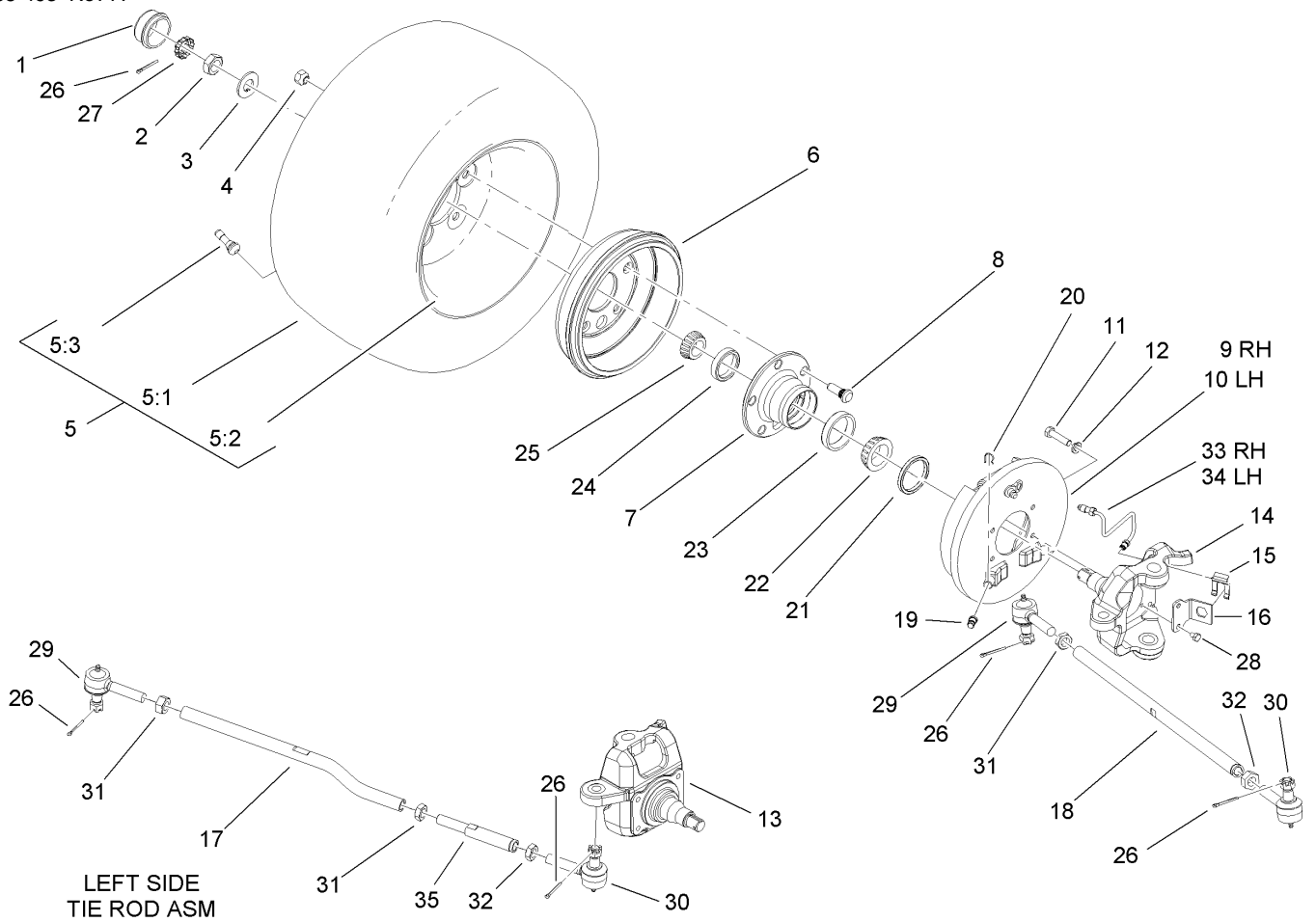

Front Wheel Assembly

Ref	Part No.	Qty.	Description
1	241-119	2	Cap-Dust
2	3220-7	2	Nut-Jam
3	93-0309	2	Washer-Tab
4	23-7270	10	Nut-Wheel
5		2	Tire And Wheel Assembly
5:1	112-3163	1	Tire
5:2	87-5720	1	Front Rim ASM
5:3	232-27	1	Stem-Valve
6	93-7128	2	Drum-Brake
7	87-5560	2	Hub-Front
8	87-8730	10	Stud
9	87-9170	1	RH Front Brake ASM
10	87-9180	1	LH Front Brake ASM
11	3235-22	8	Screw-HH, Lock
12	3253-21	8	Washer-Lock
13	108-6942	1	Spindle-LH
14	106-6746	1	Spindle-RH
15	87-3580	2	Clip-Retainer
16	106-6747	2	Bracket-Spindle
17	108-6936	1	Rod-Tie, LH
18	106-2327	1	Rod-Tie, RH
19	87-3450	2	Plug-Plate, Brake (Front)
20	87-3310	2	Clip-Cable, Brake
21	108-7019	2	Seal-Shaft

Ref	Part No.	Qty.	Description
22	254-106	2	Cone-Bearing, Tapered
23	254-107	2	Cup-Bearing, Tapered
24	254-72	2	Bearing-Cup, Tapered
25	254-94	2	Bearing-Cone, Tapered
26	3272-12	6	Pin-Cotter
27	93-0307	2	Nut-Lock, Retainer
28	321-1	4	Screw-HH
29	110-2537	2	Ball Joint-RH
30	110-2536	2	Ball Joint-LH
31	3220-11	3	Nut-Jam
32	3218-21	2	Nut-Jam
33	106-7970	1	RH Brake Tube ASM
34	106-7971	1	LH Brake Tube ASM
35	108-6937	1	Turnbuckle-Tie Rod, LH

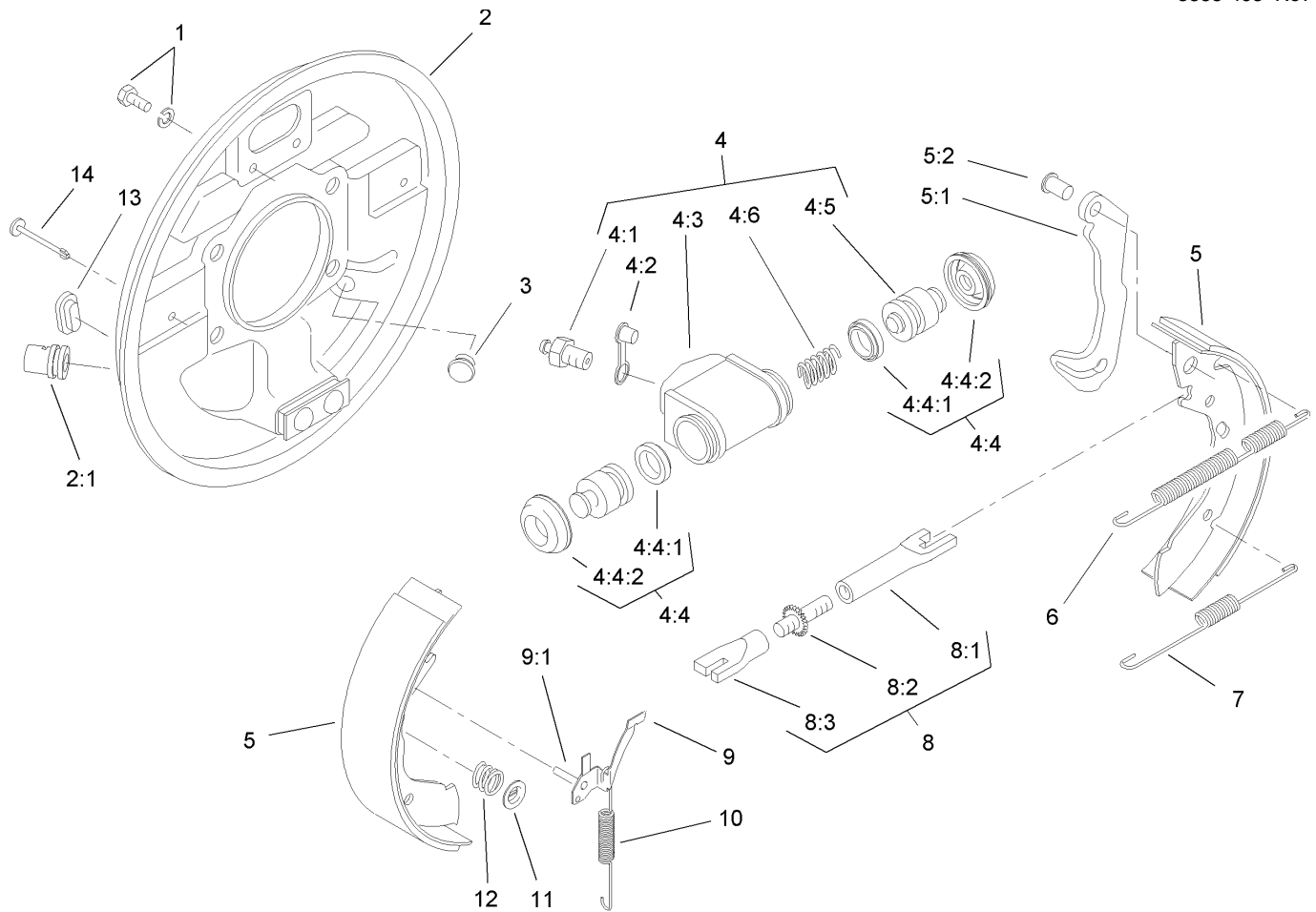

RH Front Brake Assembly No. 87-9170

Ref	Part No.	Qty.	Description
1	92-4135	2	Bolt-Set
2	92-4100	1	RH Backplate ASM
●2:1		1	Guide-Pipe
3	92-4146	1	Plunger ASM
4	92-4118	1	Wheel Cylinder ASM
4:1	92-4113	1	Screw-Bleed
4:2	92-4114	1	Cap-Screw, Bleed
●4:3		1	Body
4:4	92-4119	1	Seal Kit
●4:4:1		2	Seal-L Type
●4:4:2		2	Cover-Dust
●4:5		2	Piston
●4:6		1	Spring
5	92-4143	1	Lined Shoe Kit
●5:1		1	Lever-Operating
●5:2		1	Pin
6	92-4148	1	Spring-Return, Shoe (Upper, RH)
7	92-4149	1	Spring-Return, Shoe (Lower)
8	92-4145	1	RH Adjustor ASM
●8:1		1	Pushrod-Female
●8:2		1	Bolt-Adjuster
●8:3		1	Sleeve-Adjuster
9	92-4124	1	RH Pawl Lever ASM
●9:1		1	Pin-Pawl

Ref	Part No.	Qty.	Description
10	92-4151	1	Spring-Adjuster, RH
11	92-4131	2	Washer-Hold Down, Shoe
12	92-4152	2	Spring-Hold Down, Shoe
13	92-4134	2	Plug-Inspection
14	92-4133	2	Pin-Hold Down, Shoe

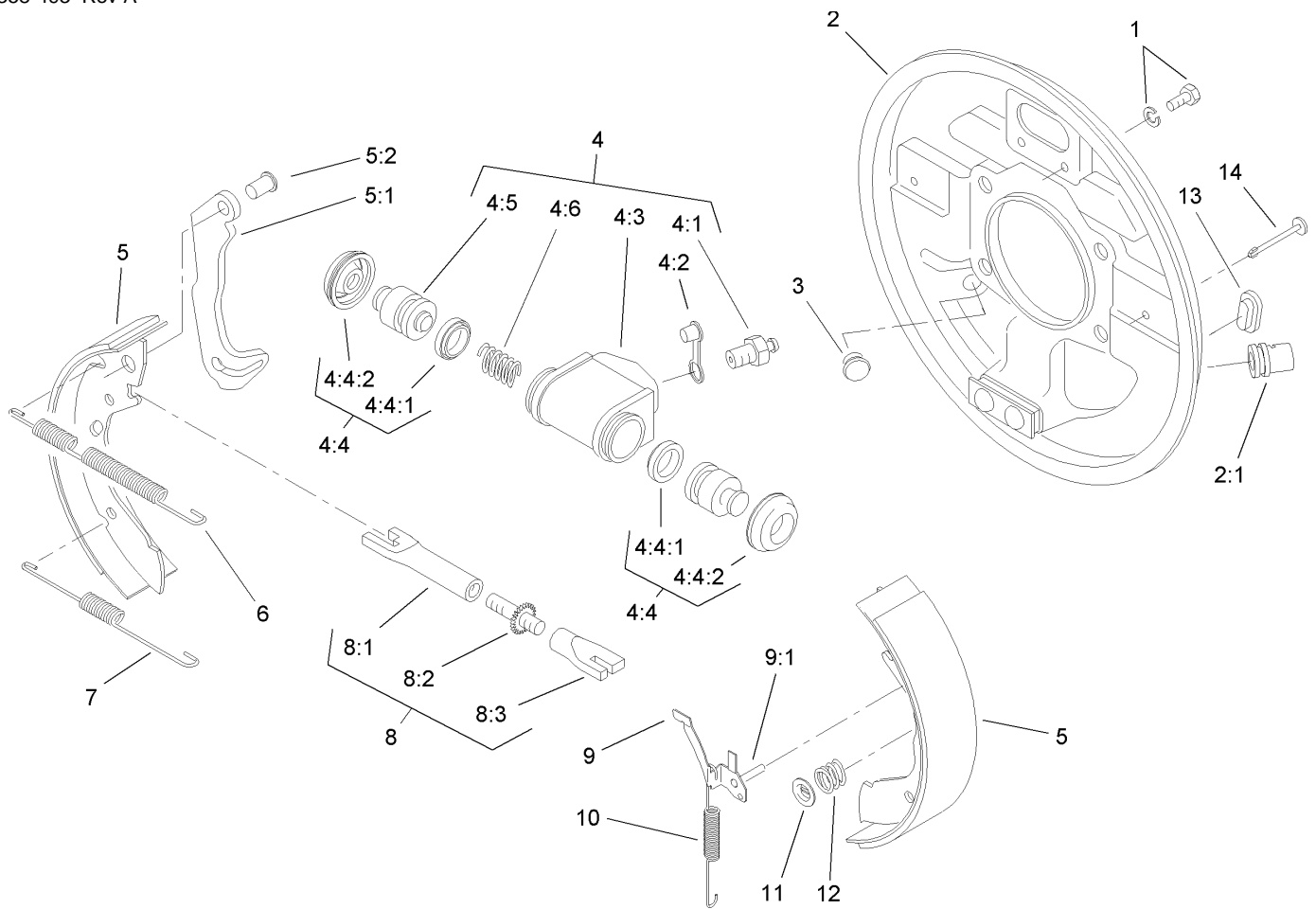

LH Front Brake Assembly No. 87-9180

Ref	Part No.	Qty.	Description
1	92-4135	2	Bolt-Set
2	92-4136	1	LH Backplate ASM
●2:1		1	Guide-Pipe
3	92-4146	1	Plunger ASM
4	92-4117	1	Wheel Cylinder ASM
4:1	92-4113	1	Screw-Bleed
4:2	92-4114	1	Cap-Screw, Bleed
●4:3		1	Body
4:4	92-4119	1	Seal Kit
●4:4:1		2	Seal-L Type
●4:4:2		2	Cover-Dust
●4:5		2	Piston
●4:6		1	Spring
5	92-4143	1	Lined Shoe Kit
●5:1		1	Lever-Operating
●5:2		1	Pin
6	92-4147	1	Spring-Return, Shoe (Upper, LH)
7	92-4149	1	Spring-Return, Shoe (Lower)
8	92-4144	1	LH Adjuster ASM
●8:1		1	Pushrod-Female
●8:2		1	Bolt-Adjuster
●8:3		1	Sleeve-Adjuster
9	92-4123	1	LH Pawl Lever ASM
●9:1		1	Pin-Pawl

Ref	Part No.	Qty.	Description
10	92-4150	1	Spring-Adjuster, LH
11	92-4131	2	Washer-Hold Down, Shoe
12	92-4152	2	Spring-Hold Down, Shoe
13	92-4134	2	Plug-Inspection
14	92-4133	2	Pin-Hold Down, Shoe

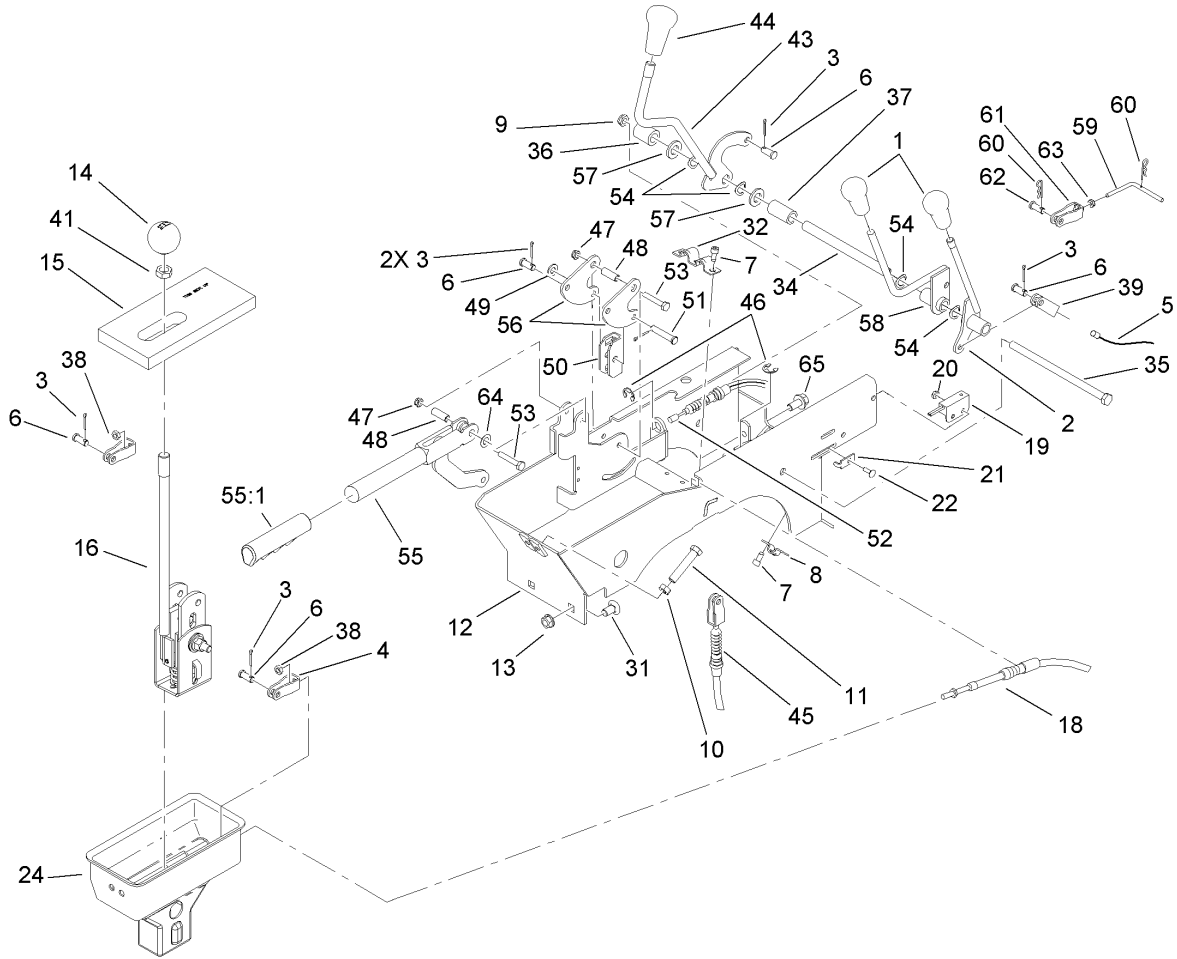

Console Assembly

Ref	Part No.	Qty.	Description
1	106-7903	2	Knob-Control
2	106-7828	1	Lever ASM
3	3272-6	6	Pin-Cotter
4	87-2310	2	Clevis-Cable
5	106-6698	1	Cable-Hi-Low
6	283-62	5	Pin-Clevis
7	65-5220	5	Screw-HSH, Thread Forming
8	87-4340	1	Clamp-Cable
9	3296-59	1	Nut-Lock, NI
10	3217-7	2	Nut-Hex
11	323-10	2	Screw-HH
12	108-6914-03	1	Lever Support ASM
13	3290-357	2	Nut-HHF, Whiz
14	87-6720	1	Knob-Shift
15	87-6570	1	Seal-Boot, Lower
16	106-7887	1	Shift ASM
18	87-4260	2	Cable-Selector, Gear
19	100-1270	1	Switch-Proximity
20	3296-12	1	Nut-Lock
21	100-4872	1	Plate-Switch, Neutral
22	3229-34	1	Bolt-CARR
24	106-2376	1	Boot-Shift, Lower
31	3231-21	2	Screw-CARR
32	87-4960	1	Clamp-Cable

Ref	Part No.	Qty.	Description
34	106-7833	1	Spacer
35	323-36	1	Screw-HH
36	66-6501	1	Spacer-Wheel
37	106-7835	1	Spacer
38	3220-1	2	Nut-Jam
39	87-7160	1	Cable Clevis ASM
41	3218-18	1	Nut-Jam
43	87-5030	1	Lever-Lock, Differential
44	106-7952	1	Knob
45	87-4460	1	Cable-Lock, Differential
46	32120-47	3	Ring-Retaining, External
47	3296-56	2	Nut-Lock, NI
48	114402	2	Spacer
49	3256-23	1	Washer-Flat
50	87-3480	1	Bracket-Equalizer, Cable
51	94-3829	1	Pin-Clevis
52	106-6691	2	Cable-Brake, Park
53	321-9	2	Screw-HH
54	3290-221	4	Washer-Spring
55	104-6842	1	Lever-Brake, Park
55:1	106-7972	1	Grip-Handle
56	106-7814	2	Bellcrank
57	33096-00	2	Washer-Flat
58	106-7960	1	HYD Lever ASM

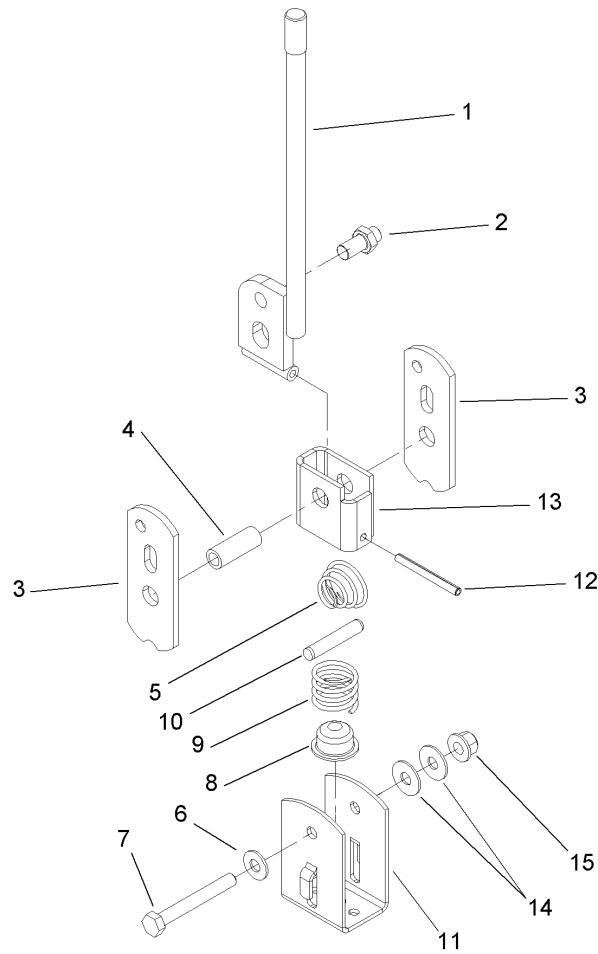

Shift Assembly No. 106-7887

Ref	Part No.	Qty.	Description
1	87-2040	1	Shift Lever ASM
2	87-3650	1	Pin-Shift
3	87-3540	2	Link-Shift
4	87-2520	1	Tube-Pivot
5	87-2900	1	Spring-Compression
6	87-8640	1	Washer-Flat
7	322-12	1	Screw-HH
8	87-3530	1	Button-Shifter
9	87-3660	1	Spring-Compression
10	3290-507	1	Pin-Dowel
11	87-3520	1	Clevis
12	32121-48	1	Pin-Spring
13	87-6040	1	Bracket-Shifter
14	3290-456	2	Washer-Belleville
15	3296-58	1	Nut-Lock, NI

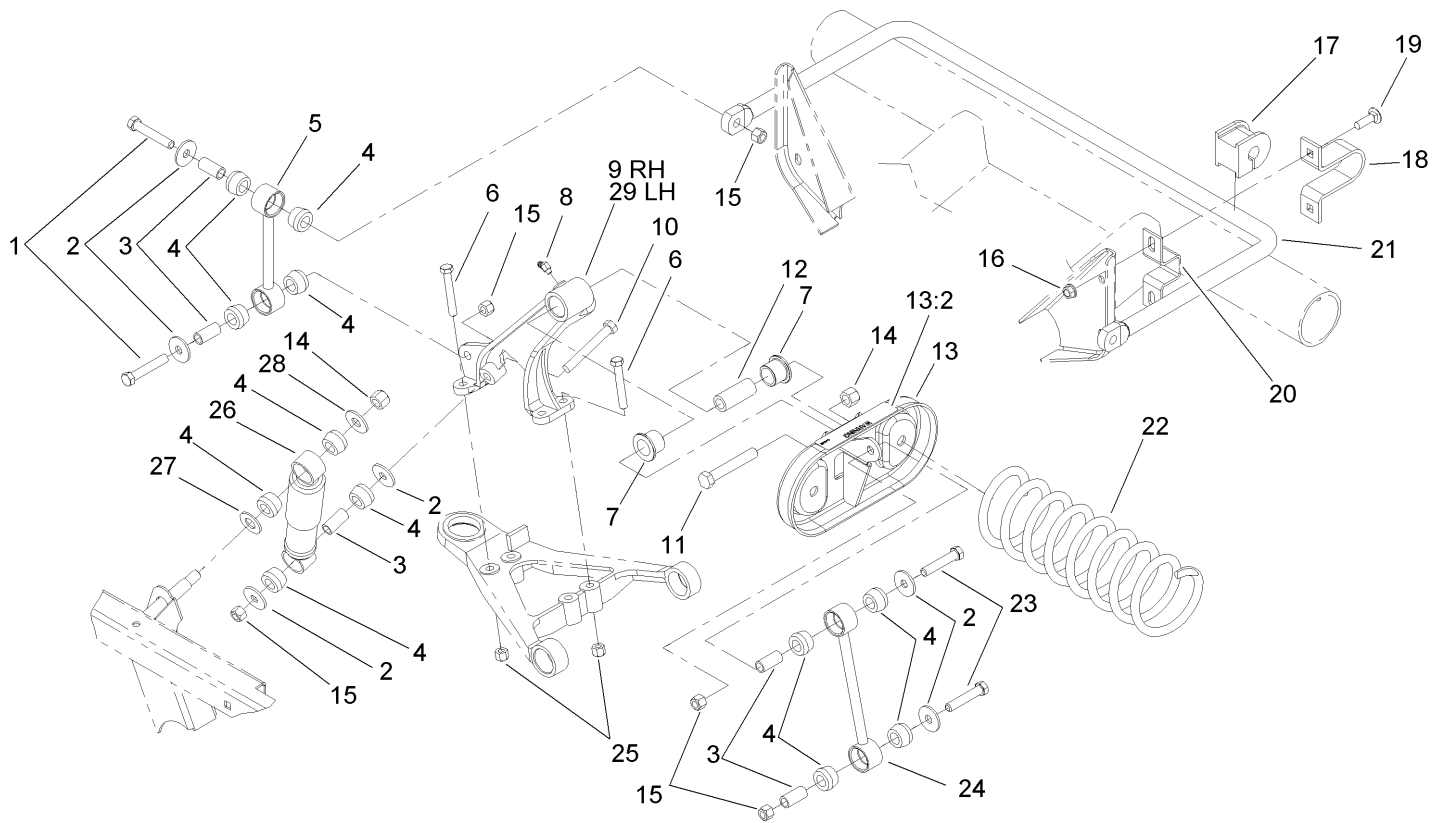

Front Suspension Assembly

Ref	Part No.	Qty.	Description
1	324-10	4	Screw-HH
2	87-5330	12	Washer
3	87-3600	10	Spacer-Absorber, Shock
4	87-3920	24	Bushing
5	87-3860-03	2	Anti-Sway Bar Link ASM
6	323-12	8	Screw-HH
7	33-3090	4	Bushing
8	302-11	2	Fitting-Lube, 45 DEG
9	87-0150-03	1	Tower-Control Arm, RH
10	324-13	2	Screw-HH
11	325-13	2	Screw-HH
12	87-2500	2	Sleeve-Spring, Pivot
13	105-7958	2	Spring Cradle ASM
13:2	93-9879	1	Decal-Warning
14	3296-23	4	Nut-Lock, NI
15	3296-48	10	Nut-Lock, NI
16	3290-357	4	Nut-HHF, Whiz
17	87-3910	2	Bushing-Rubber
18	87-4010-03	2	Clamp-Bar, Sway
19	3231-25	4	Screw-CARR
20	87-3890-03	2	Bracket-Bar, Sway
21	87-3850-03	1	Bar-Sway, Anti
22	105-4183-01	2	Spring-Compression
23	324-9	4	Screw-HH

Ref	Part No.	Qty.	Description
24	106-2302-03	2	Stabilizer Link ASM
25	3296-39	8	Nut-Lock, NI
26	87-3110	2	Absorber-Shock
27	3256-27	2	Washer-Flat
28	3256-6	2	Washer-Flat
29	87-0160-03	1	Tower-Control Arm, LH

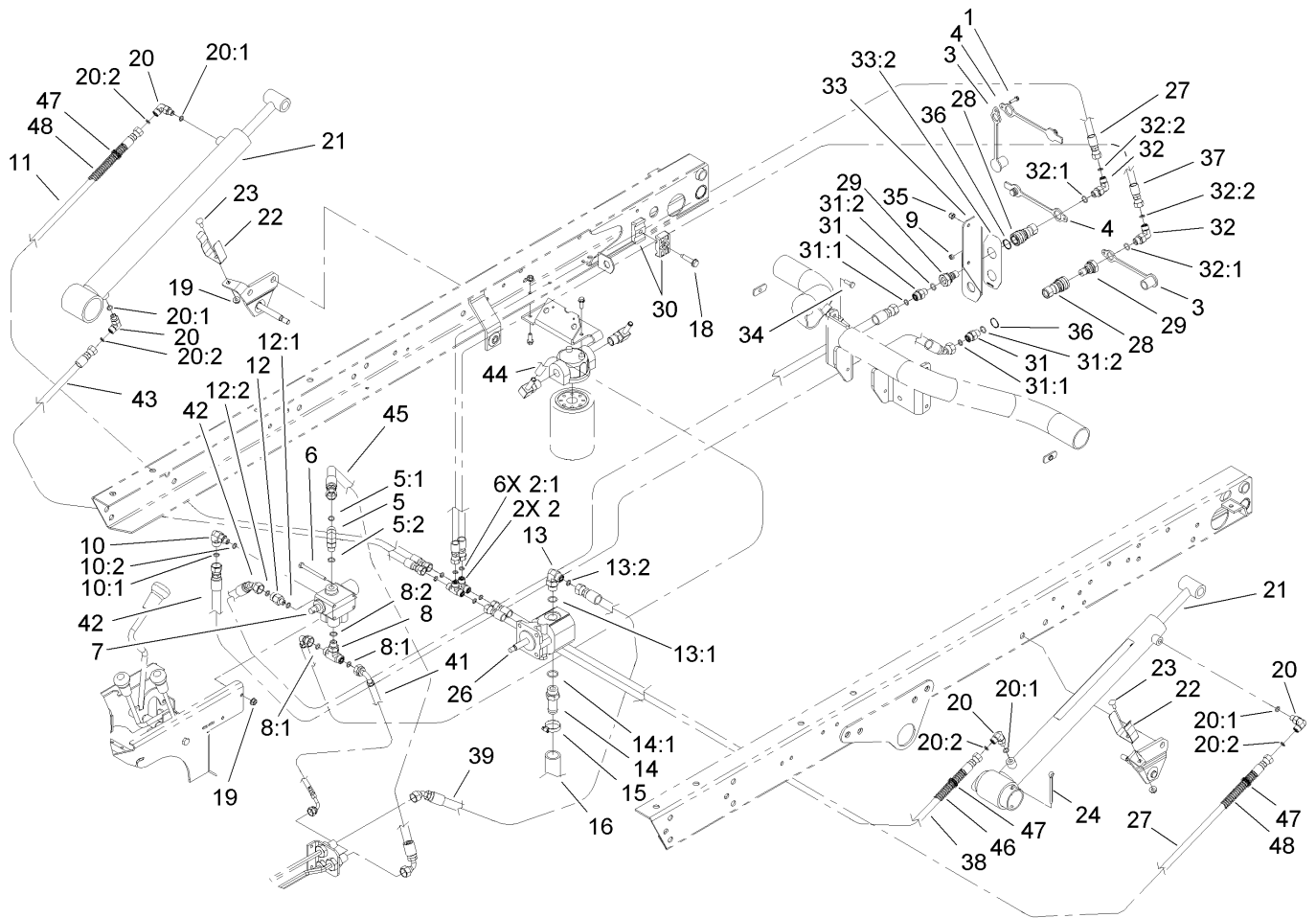

Lift Valve and Hydraulic Assembly

Ref	Part No.	Qty.	Description
1	32105-13	1	Screw-SHH
2	340-21	2	Fitting
2:1	237-21	3	O-Ring
3	106-7881	2	Cap-Dust, HYD
4	106-7882	2	Plug-Dust, HYD
5	340-77	1	Fitting-HYD, 90 DEG
5:1	237-22	1	O-Ring
5:2	237-42	1	O-Ring
6	321-14	2	Screw-HH
7	43-1950	1	Valve-Control, HYD
8	340-94	1	Adapter
8:1	237-22	2	O-Ring
8:2	237-42	1	O-Ring
9	3296-2	1	Nut-Lock
10	340-97	1	Fitting-HYD, 90 DEG
10:1	237-22	1	O-Ring
10:2	237-78	1	O-Ring
11	92-7564	1	Hose ASM
12	340-88	1	Adapter
12:1	237-22	1	O-Ring
12:2	237-78	1	O-Ring
13	340-18	1	Fitting-HYD, 90 DEG
13:1	237-79	1	O-Ring
13:2	237-22	1	O-Ring

Ref	Part No.	Qty.	Description
14	354-136	1	Fitting-HYD
14:1	237-80	1	O-Ring
15	2412-34	1	Clamp-Hose
16	87-3670	1	Hose-Suction
18	32144-57	1	Screw
19	32128-33	4	Nut-HF
20	340-132	4	Fitting-HYD, 90 DEG
20:1	237-78	1	O-Ring
20:2	237-21	1	O-Ring
21	106-7939	2	HYD Cylinder ASM
22	108-3109	2	Retainer-Cylinder
23	3229-1	2	Screw-CARR
24	3272-37	2	Pin-Cotter
26	106-6649	1	Pump-Gear, HYD
27	104-3716	2	HYD Hose ASM
28	106-7968	2	Coupler-Quick, Female
29	106-7969	2	Coupler-Quick, Male
30	56-7976	2	Clamp-Tube
31	340-2	2	Fitting-HYD, Straight
31:1	237-22	1	O-Ring
31:2	237-42	1	O-Ring
32	340-82	2	Adapter
32:1	237-42	1	O-Ring
32:2	237-21	1	O-Ring

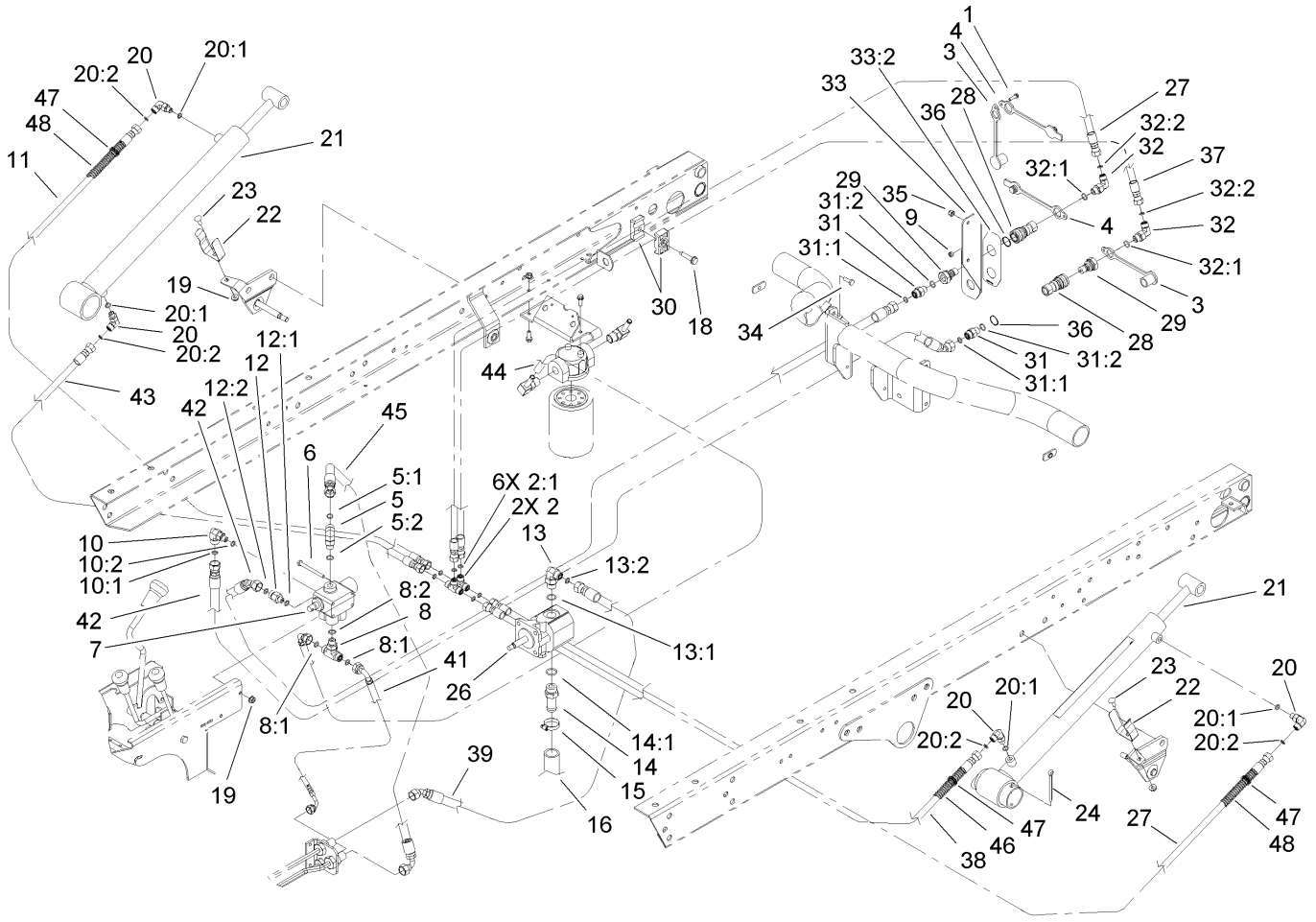

Lift Valve and Hydraulic Assembly (continued)

Ref	Part No.	Qty.	Description
33	106-7923	1	Quick Coupler Bracket ASM
33:2	106-7888	1	Decal-Couplers, Quick
34	3234-21	2	Screw-Cap
35	3296-42	2	Nut-Lock, NI
36	32151-83	2	Ring-Snap
37	98-4584	1	HYD Hose ASM
38	98-4590	1	Hose ASM
39	95-0965	1	Hose ASM
41	106-7964	1	Hose-HYD
42	106-7977	2	Hose-HYD
43	106-7981	1	Hose-HYD
44	106-7965	1	Hose-HYD
45	95-8828	1	Hose-HYD
46	24-7922	1	Cover-Shaft, Drive
47	3290-378	6	Tie-Cable
48	24-7923	2	Cover-Shaft, Drive

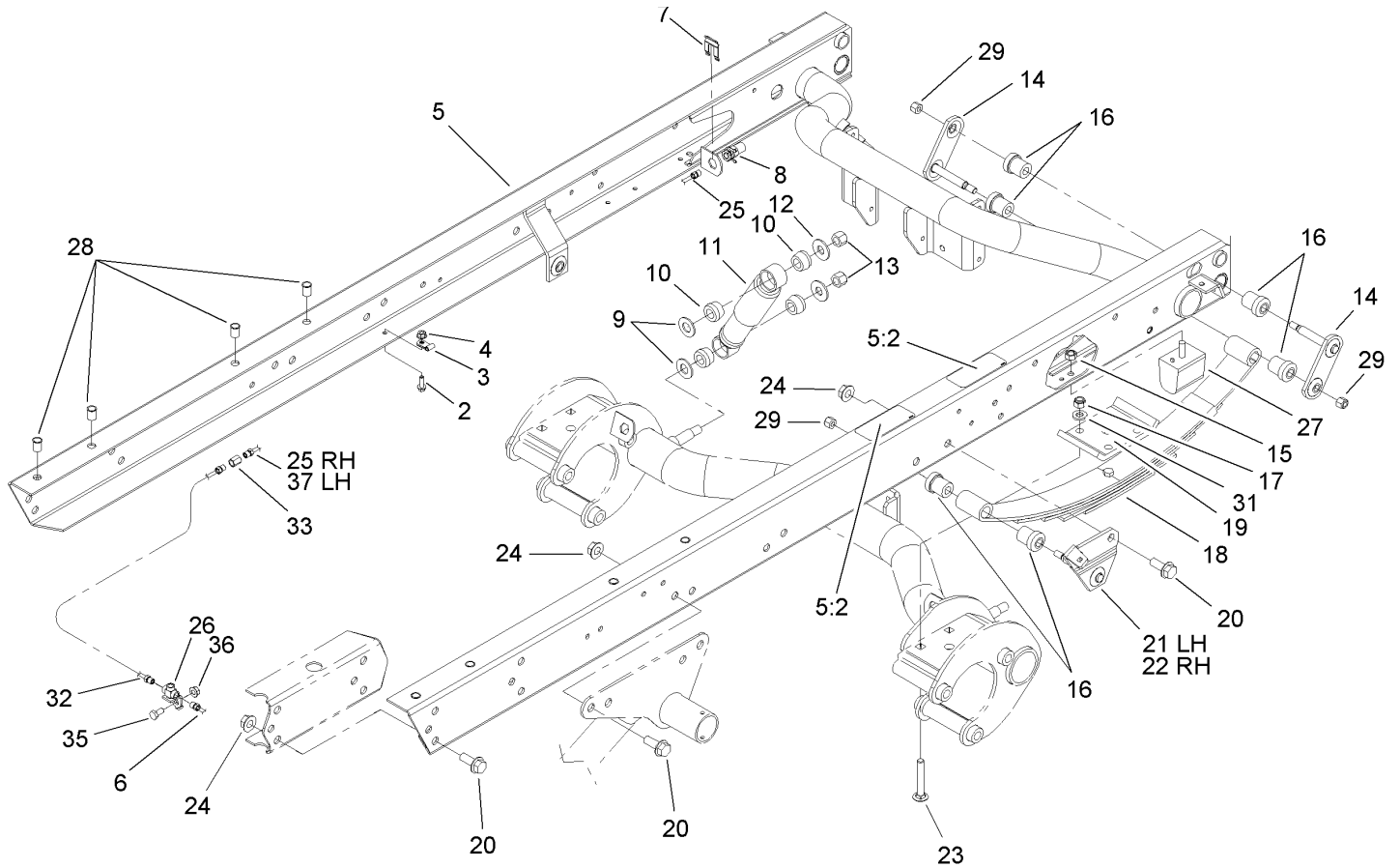

Rear Frame Assembly

Ref	Part No.	Qty.	Description
2	3234-4	4	Screw-HHF
3	2412-149	4	Clamp-Hose
4	32128-33	4	Nut-HF
5	105-7959	1	Frame Channel ASM
5:2	93-8071	2	Decal-Surface, Hot
6	94-3843	1	LH Rear Brake Tube ASM
7	87-3580	2	Clip-Retainer
8	87-4100	2	Hose-Brake, Rear
9	3256-27	4	Washer-Flat
10	87-3920	8	Bushing
11	87-3110	2	Absorber-Shock
12	3256-6	4	Washer-Flat
13	3296-23	4	Nut-Lock, NI
14	87-3980	4	Shackle ASM
15	48-9520	2	Nut
16	87-4760	12	Bushing-Rubber
17	3296-76	8	Nut-Lock, NI
18	87-1490	2	Spring-Leaf, Rear
19	87-7470-03	2	Plate-Spring, Clamp
20	3234-38	24	Screw-HHF
21	87-3960	1	LH Spring Mount ASM
22	87-3940	1	RH Spring Mount ASM
23	3232-17	8	Screw-CARR
24	32128-23	24	Nut-HF

Ref	Part No.	Qty.	Description
25	94-3846	1	RH Rear Brake Tube ASM
26	87-3560	1	Tee
27	87-3470	2	Bumper-Axle, Rear
28	32148-9	8	Insert-Nut
29	3296-39	6	Nut-Lock, NI
31	87-7480	8	Washer
32	94-3845	1	RH Rear Brake Tube ASM
33	87-3570	2	Union
35	322-2	1	Screw-HH
36	32128-20	1	Nut-HF
37	94-3844	1	LH Rear Brake Tube ASM

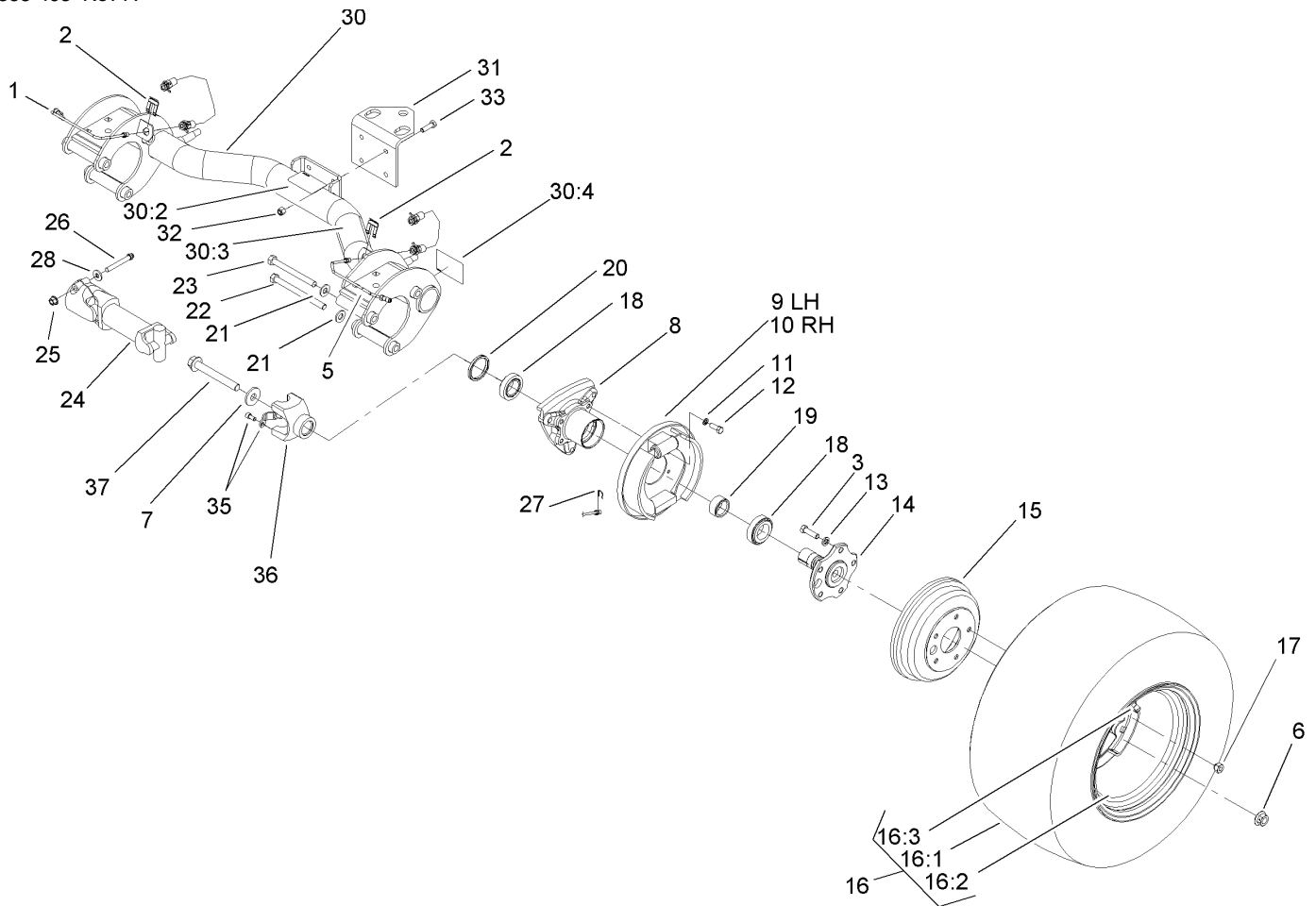

Rear Axle Assembly

Ref	Part No.	Qty.	Description
1	87-4090	1	RH Rear Brake Tube ASM
2	87-3580	2	Clip-Retainer
3	87-2080	10	Bolt-Hex, TAP
5	87-4080	1	LH Rear Brake Tube ASM
6	105-1764	2	Nut-Flange, Side Lock
7	104-9216	2	Washer-Hardened
8	87-2240	2	Housing-Axle
9	93-7126	1	LH Rear Brake ASM
10	93-7125	1	RH Rear Brake ASM
11	3253-21	8	Washer-Lock
12	3235-22	8	Screw-HH, Lock
13	3253-6	10	Washer-Lock
14	105-1717-03	2	Axle-Stub
15	93-7128	2	Drum-Brake
16		2	Tire And Wheel ASM
16:1	106-7868	1	Tire
16:2	87-6750	1	Wheel
16:3	232-27	1	Stem-Valve
17	23-7270	10	Nut-Wheel
18	87-1970	2	Bearing
19	87-4060	2	Spacer-Bearing, Wheel
20	108-7019	2	Seal-Shaft
21	87-7270	6	Washer-Thrust
22	325-20	5	Screw-HH

Ref	Part No.	Qty.	Description
23	325-19	1	Screw-HH
24	98-2918	2	Driveshaft ASM
25	32128-36	4	Nut-HF
26	98-2939	4	Screw-Cap
27	87-3310	2	Clip-Cable, Brake
28	80-6990	4	Washer-Hardened
30	105-7961	1	Rear Axle ASM
30:2	93-9442	1	Decal-Atf
30:3	93-9862	1	Decal-Danger
30:4	93-9449	2	Decal-Driveshaft
31	92-5951-03	1	Angle-Hitch
32	3296-39	4	Nut-Lock, NI
33	323-7	4	Screw-HH
35	92-4189	2	Strap Kit
36	92-4190	2	Yoke
37	105-1763	2	Screw-HHF

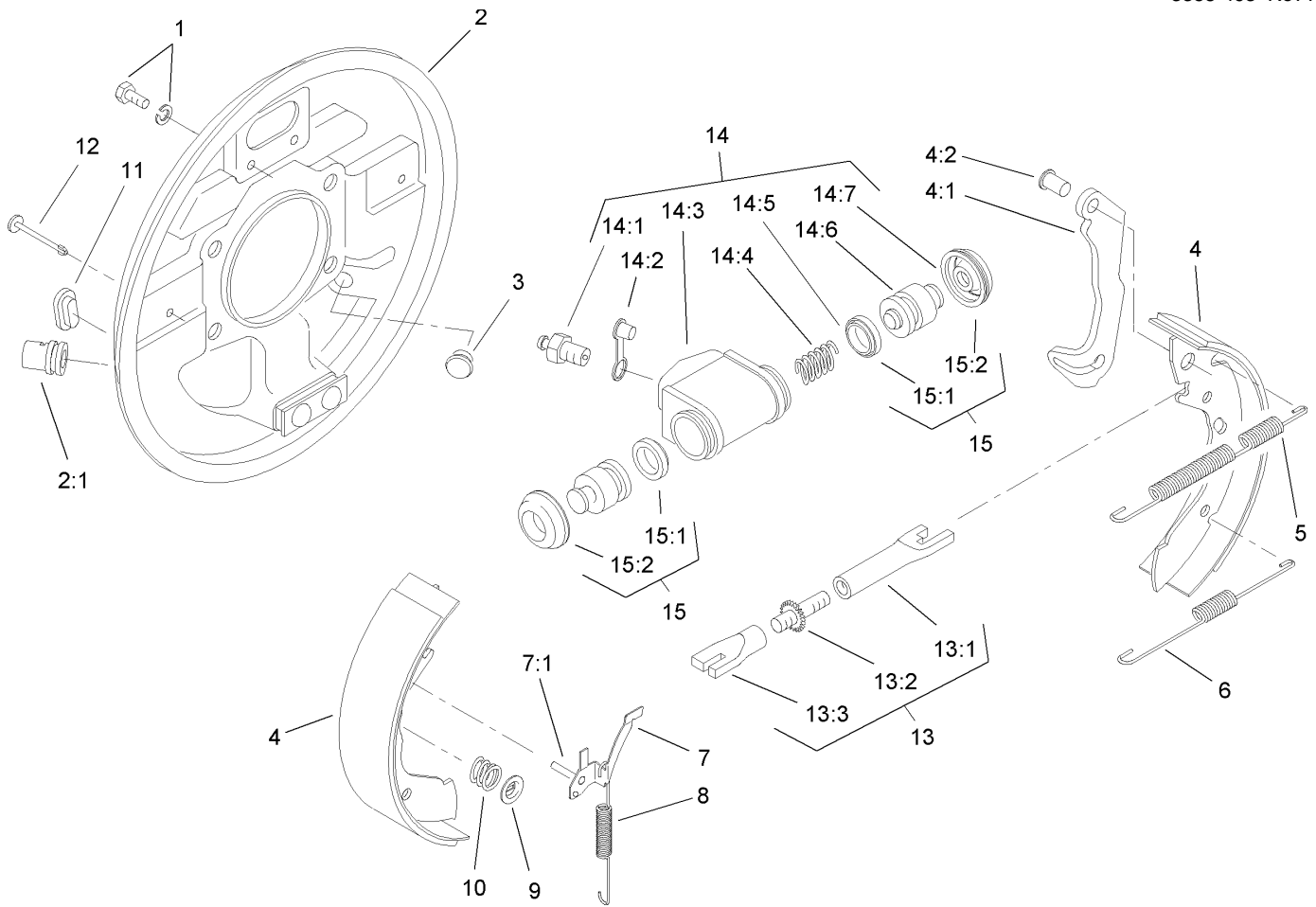

LH Rear Brake Assembly No. 93-7126

Ref	Part No.	Qty.	Description
1	92-4135	2	Bolt-Set
2	92-4136	1	LH Backplate ASM
●2:1		1	Guide-Pipe
3	92-4146	1	Plunger ASM
4	92-4143	1	Lined Shoe Kit
●4:1		1	Lever-Operating
●4:2		1	Pin
5	92-4147	1	Spring-Return, Shoe (Upper, LH)
6	92-4149	1	Spring-Return, Shoe (Lower)
7	92-4123	1	LH Pawl Lever ASM
●7:1		1	Pin-Pawl
8	92-4150	1	Spring-Adjuster, LH
9	92-4131	2	Washer-Hold Down, Shoe
10	92-4152	2	Spring-Hold Down, Shoe
11	92-4134	1	Plug-Inspection
12	92-4133	2	Pin-Hold Down, Shoe
13	92-4144	1	LH Adjuster ASM
●13:1		1	Pushrod-Female
●13:2		1	Bolt-Adjuster
●13:3		1	Sleeve-Adjuster
14	92-4140	1	LH Wheel Cylinder ASM
14:1	92-4137	1	Screw-Bleed
14:2	92-4114	1	Cap-Screw, Bleed
●14:3		1	Body

Ref	Part No.	Qty.	Description
●14:4		1	Spring
●14:5		2	Seal-L Type
●14:6		2	Piston
●14:7		2	Cover-Dust
15	92-4142	1	Seal Kit
●15:1		2	Seal-L Type
●15:2		2	Cover-Dust

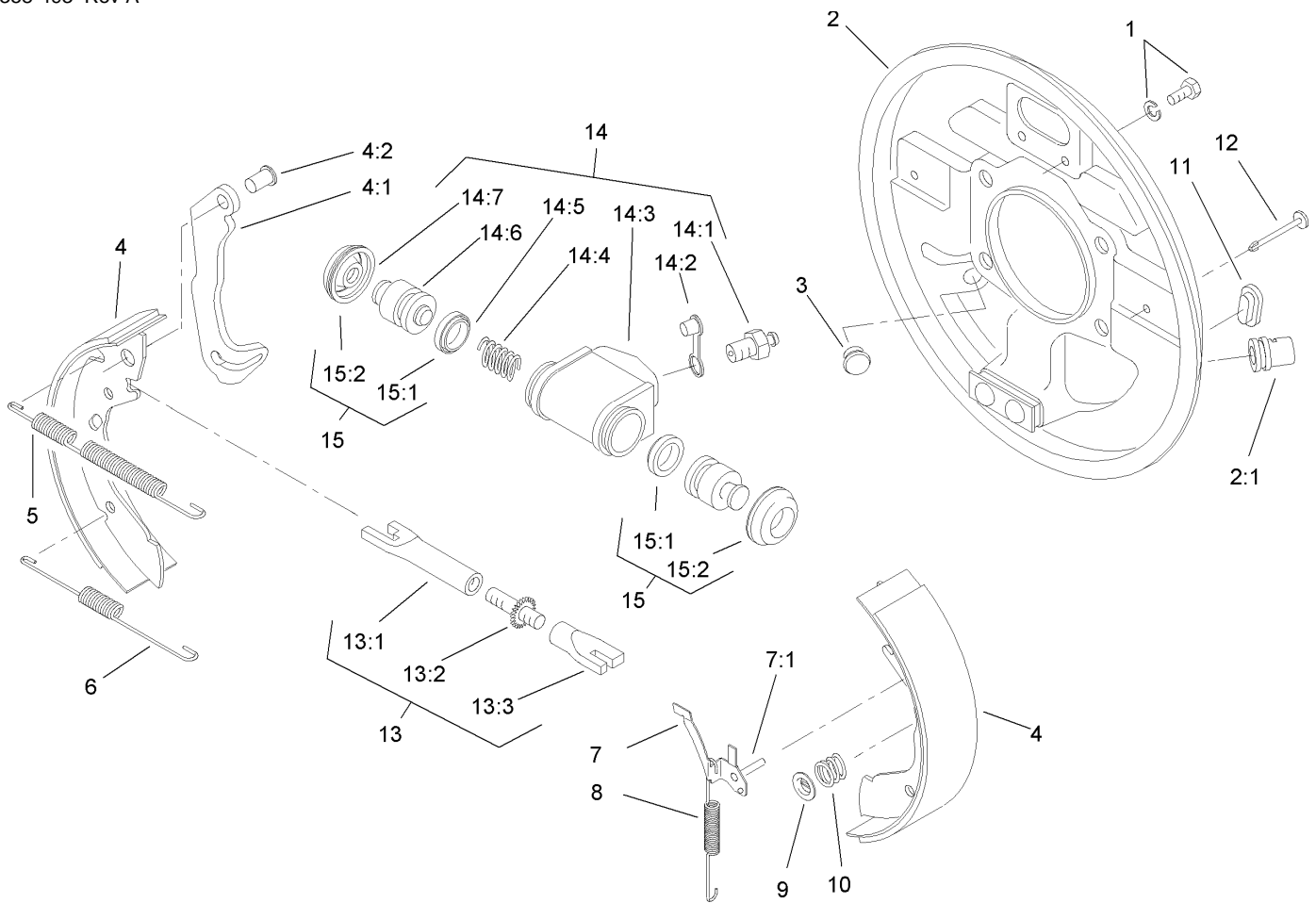

RH Rear Brake Assembly No. 93-7125

Ref	Part No.	Qty.	Description
1	92-4135	2	Bolt-Set
2	92-4100	1	RH Backplate ASM
●2:1		1	Guide-Pipe
3	92-4146	1	Plunger ASM
4	92-4143	1	Lined Shoe Kit
●4:1		1	Lever-Operating
●4:2		1	Pin
5	92-4148	1	Spring-Return, Shoe (Upper, RH)
6	92-4149	1	Spring-Return, Shoe (Lower)
7	92-4124	1	RH Pawl Lever ASM
●7:1		1	Pin-Pawl
8	92-4151	1	Spring-Adjuster, RH
9	92-4131	2	Washer-Hold Down, Shoe
10	92-4152	2	Spring-Hold Down, Shoe
11	92-4134	1	Plug-Inspection
12	92-4133	2	Pin-Hold Down, Shoe
13	92-4145	1	RH Adjustor ASM
●13:1		1	Pushrod-Female
●13:2		1	Bolt-Adjuster
●13:3		1	Sleeve-Adjuster
14	92-4141	1	RH Wheel Cylinder ASM
14:1	92-4137	1	Screw-Bleed
14:2	92-4114	1	Cap-Screw, Bleed
●14:3		1	Body

Ref	Part No.	Qty.	Description
●14:4		1	Spring
●14:5		2	Seal-L Type
●14:6		2	Piston
●14:7		2	Cover-Dust
15	92-4142	1	Seal Kit
●15:1		2	Seal-L Type
●15:2		2	Cover-Dust

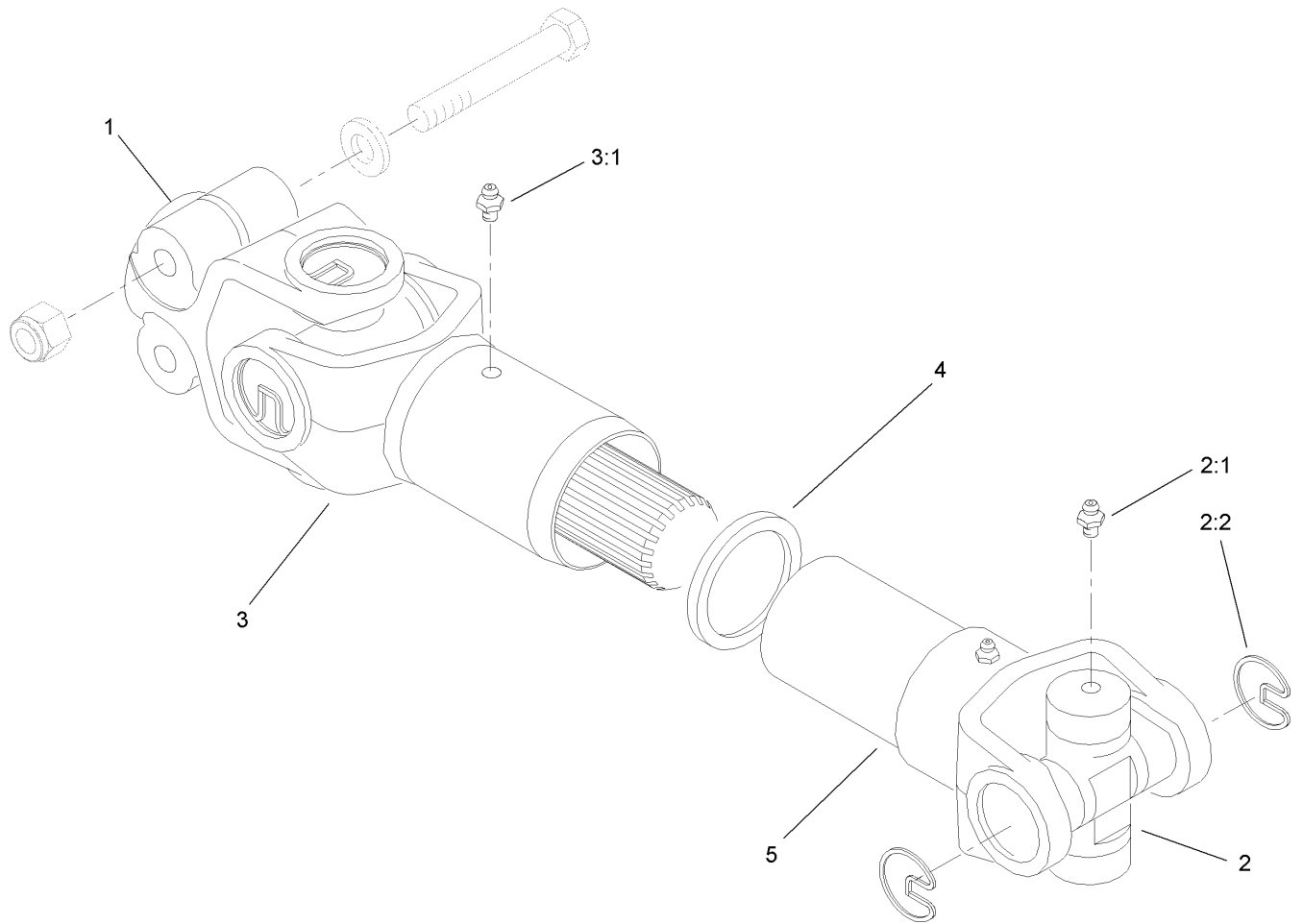

Driveshaft Assembly No. 98-2918

Ref	Part No.	Qty.	Description
1	98-2940	1	Yoke
2	92-4187	2	Cross And Bearing Kit
2:1	302-58	2	Fitting-Straight
2:2	92-4188	2	Ring-Snap
3	92-4179	1	Yoke-Tube, Shaft And Seal
3:1	302-5	1	Fitting-Grease
4	92-4180	1	Seal
5	92-4182	1	Yoke And Hub

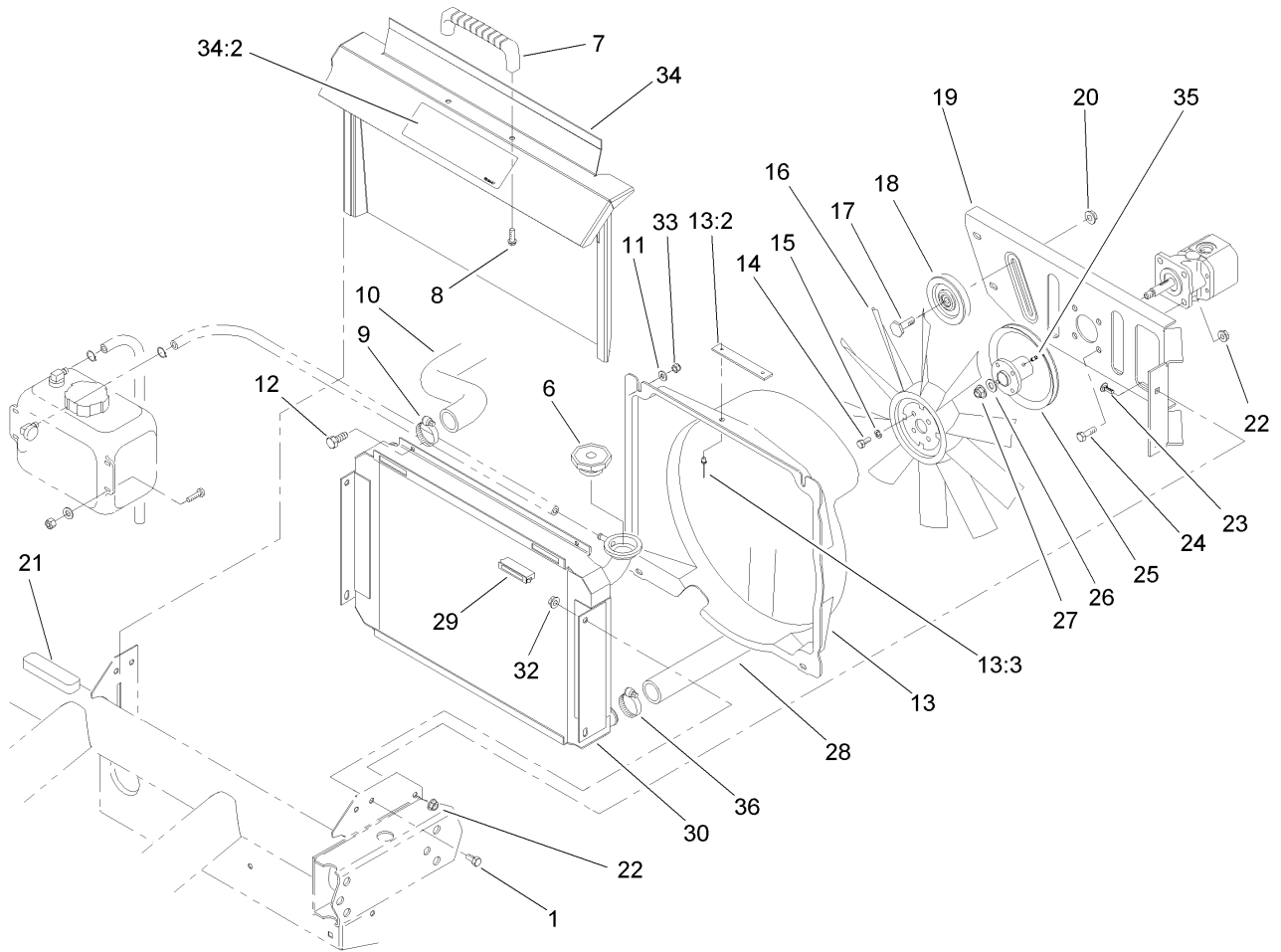

Radiator and Hydraulic Pump Assembly

Ref	Part No.	Qty.	Description
1	322-2	4	Screw-HH
6	66-3240	1	Cap-Radiator
7	65-5100	1	Handle-Door
8	46-8091	2	Screw-HWH
9	2412-34	1	Clamp-Hose
10	105-1724	1	Hose-Radiator, Upper
11	3256-22	4	Washer-Flat
12	321-4	4	Screw-HH
13	105-7956	1	Fan Shroud ASM
13:2	98-9335	1	Plate-Warning, Fan
13:3	3290-271	2	Rivet-Pop
14	321-3	4	Screw-HH
15	3253-3	4	Washer-Lock
16	84-1880	1	Fan
17	32141-86	1	Screw-Leveler
18	63-8140	1	Pulley-Idler
19	93-7088-03	1	Plate-Mount, Pump
20	3290-357	1	Nut-HHF, Whiz
21	87-9810	1	Foam-Overflow, Tank
22	3296-29	8	Nut-Lock, NI
23	3230-23	4	Screw-CARR
24	322-5	4	Screw-HH
25	94-5237	1	Fan Hub ASM
26	3256-45	1	Washer-Flat

Ref	Part No.	Qty.	Description
27	3296-5	1	Nut-Lock
28	105-1725	1	Hose-Radiator, Lower
29	58-4250	2	Catch-Magnetic
30	93-7051	1	Radiator
32	32128-20	4	Nut-HF
33	3296-42	4	Nut-Lock, NI
34	105-4223	1	Radiator Cover ASM
34:2	93-9447	1	Decal-Caution
35	3245-31	1	Screw-HSH
36	2412-3	1	Clamp-Hose

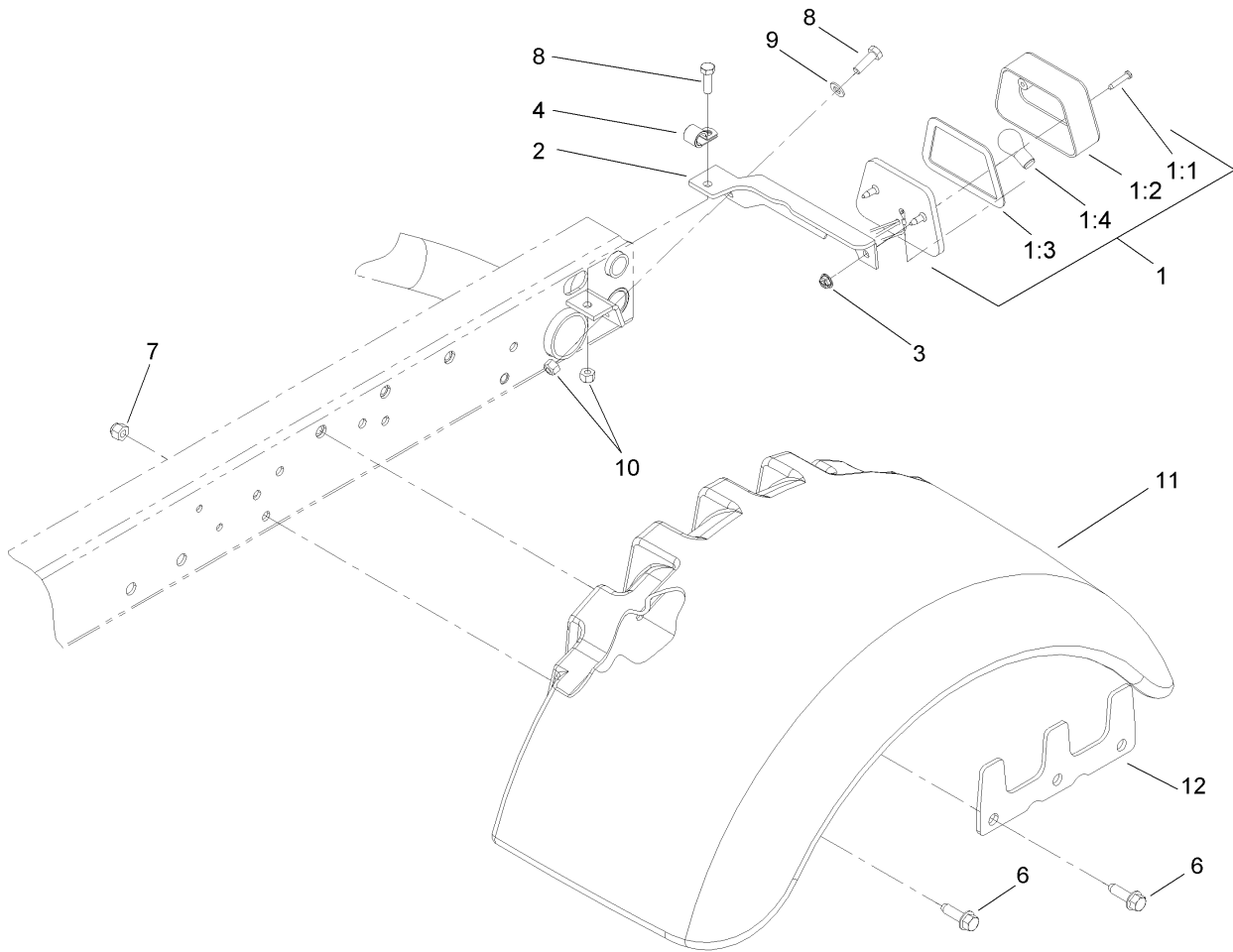

Tail Light and Fender Assembly

Ref	Part No.	Qty.	Description
1	87-2110	1	Light-Tail / Brake
1:1	32144-93	4	Screw-PPHTF
1:2	87-6300	2	Lens-Light, Tail
1:3	87-6310	2	Gasket-Light, Tail
1:4		1	Bulb
2	106-7872-03	1	LH Tail Light Bracket ASM
3	3290-506	2	Palnut
4	2412-93	1	Clamp-R
6	32144-109	10	Screw
7	3296-39	2	Nut-Lock, NI
8	322-5	2	Screw-HH
9	3256-23	1	Washer-Flat
10	3296-29	2	Nut-Lock, NI
11	106-2373	2	Fender-Rear
12	106-7895-03	2	Plate-Support

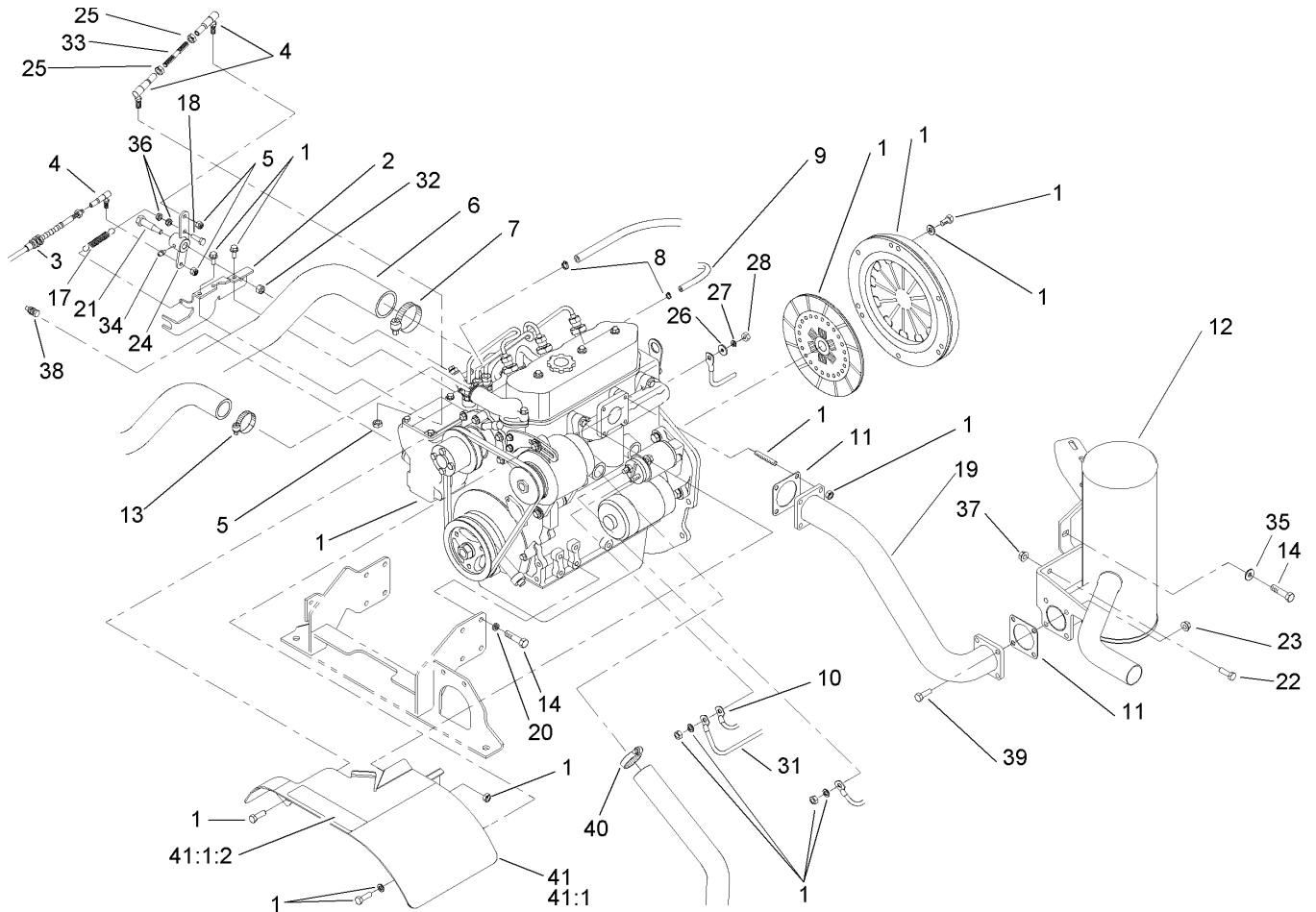

Diesel Engine Assembly

Ref	Part No.	Qty.	Description
1	105-4152	1	Engine ASM
2	106-2403	1	Bracket-Throttle, Diesel
3	110-2549	1	Cable-Accelerator, Liquid-Cooled
4	18-1720	3	Governor Ball Joint ASM
5	3296-3	3	Nut-Lock
6	107-7960	1	Hose-Intake
7	2412-92	1	Clamp-Hose
8	2412-108	2	Clamp-Worm
9	109-0289	1	Hose-Fuel
10	99-3441	1	Harness-Wire, Fusible Link
11	105-4209	2	Gasket-Muffler
12	105-1778	1	Muffler-Exhaust
13	2412-34	1	Clamp-Hose
14	33114-020	9	Screw-HH
17	86-4760	1	Spring-Extension
18	321-5	1	Screw-HH
19	108-3066	1	Exhaust Tube ASM
20	3253-4	8	Washer-Lock
21	7-0030	1	Bolt-Shoulder
22	322-5	2	Screw-HH
23	32128-25	4	Nut-HF
24	105-1726	1	Bell Crank ASM
25	3220-1	2	Nut-Jam
26	3256-2	1	Washer-Flat

Ref	Part No.	Qty.	Description
27	43-5920	1	Washer-Lock, Spring
28	48-7880	1	Nut-Hex
31	110-1654	1	Cable-Positive
32	3296-29	1	Nut-Lock, NI
33	105-1789	1	Rod-Threaded
34	302-5	1	Fitting-Grease
35	87-8640	1	Washer-Flat
36	3296-56	2	Nut-Lock, NI
37	32128-20	2	Nut-HF
38	94-7621	1	Sender-Temperature
39	3274-22	4	Screw-HSH
40	2412-3	1	Clamp-Hose
41	105-7996	1	Engine Cover Kit
41:1		1	Engine Cover ASM
41:1:2	93-7814	1	Decal-Danger

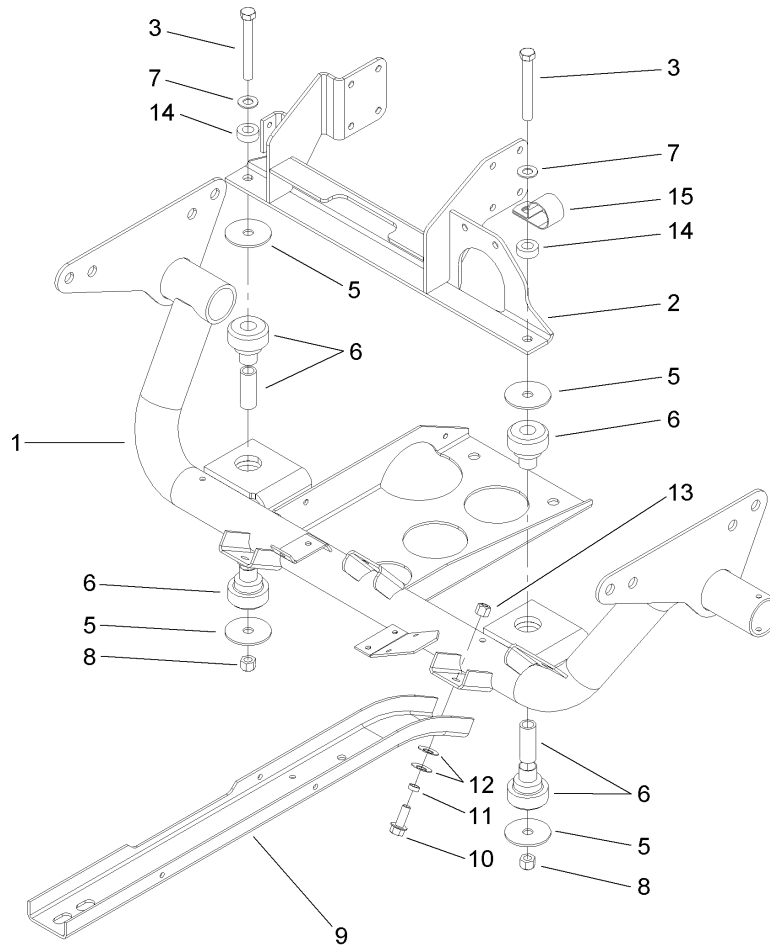

Engine Support Assembly

Ref	Part No.	Qty.	Description
1	105-4200-03	1	Engine Support ASM
2	104-9238-03	1	Engine Mount ASM
3	324-19	2	Screw-HH
5	87-5100	4	Washer-Snubbing
6	106-7865	2	Engine Mount ASM
7	3256-25	2	Washer-Flat
8	3296-48	2	Nut-Lock, NI
9	87-4730-03	2	Guard-Belly
10	3234-11	6	Screw-HHF
11	76-9100	6	Spacer-Speed, Reel
12	3290-413	12	Washer-Belleville
13	3296-39	6	Nut-Lock, NI
14	59-2290	2	Spacer
15	2412-82	1	Clamp

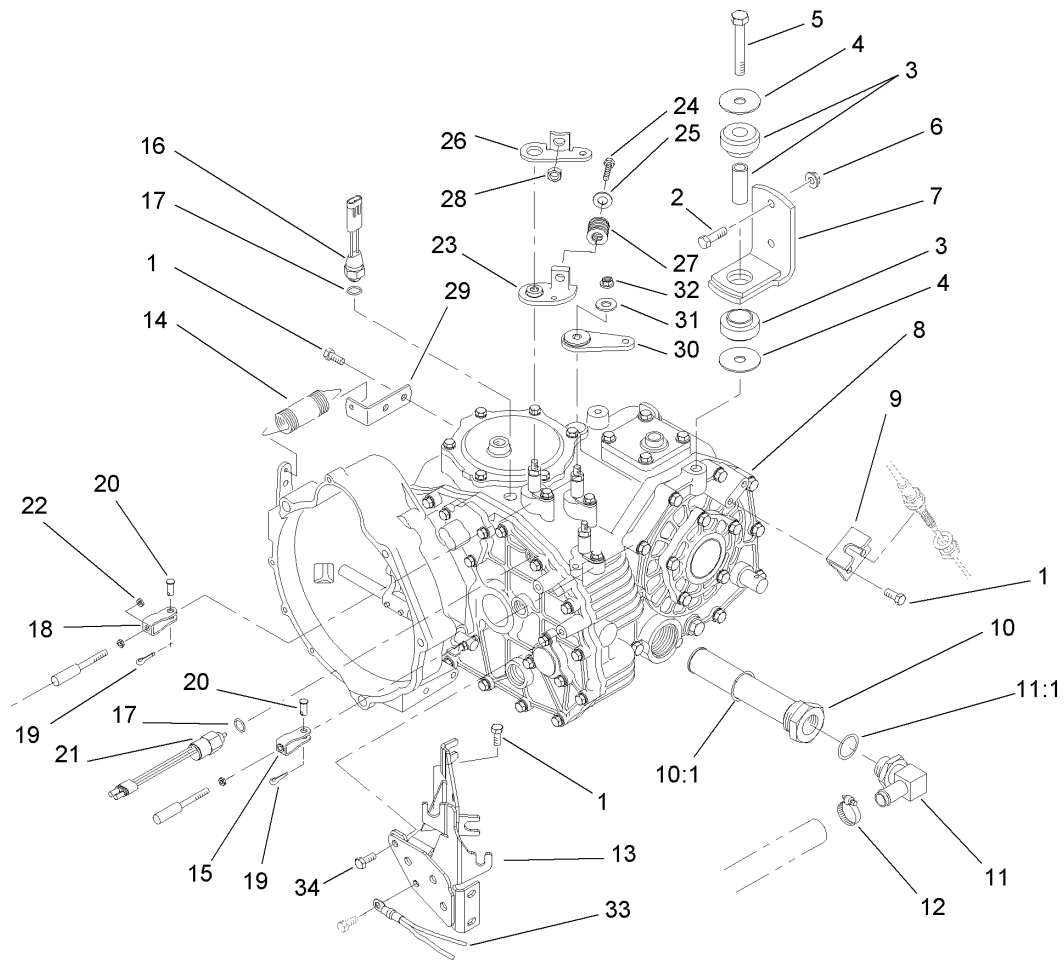

Transaxle Assembly

Ref	Part No.	Qty.	Description
1	33114-020	5	Screw-HH
2	323-7	4	Screw-HH
3	106-7865	2	Engine Mount ASM
4	87-5100	4	Washer-Snubbing
5	33116-080	2	Screw-HH
6	3296-39	4	Nut-Lock, NI
7	87-5800-03	2	Transaxle Mount ASM
8	105-4180	1	2 Wheel Drive Transaxle ASM
9	87-4470	1	Bracket-Lock, Differential
10	87-3990	1	Strainer-Transaxle
10:1	237-123	1	O-Ring
11	353-987	1	Fitting-HYD, 90
11:1	237-81	1	O-Ring
12	2412-34	1	Clamp-Hose
13	105-4207-03	1	Cable Mount ASM
14	68-9950	1	Spring-Traction
15	87-7160	1	Cable Clevis ASM
16	72-4310	1	Switch-Ball
17	237-30	2	O-Ring
18	87-2310	2	Clevis-Cable
19	3272-6	3	Pin-Cotter
20	283-62	3	Pin-Clevis
21	87-6710	1	Switch-Transmission
22	3220-1	2	Nut-Jam

Ref	Part No.	Qty.	Description
23	87-7970	1	Arm-Shift
24	323-10	1	Screw-HH
25	3256-4	1	Washer-Flat
26	87-8250	1	Plate-Arm, Shift
27	87-6910	1	Spring-Compression
28	32128-21	1	Nut-HF
29	87-7170	1	Bracket-Spring, Clutch
30	87-7960	2	Lever-Shift
31	80-6990	3	Washer-Hardened
32	48-9520	3	Nut
33	87-3080	1	Cable-Battery, Negative
34	33114-025	2	Screw-HH

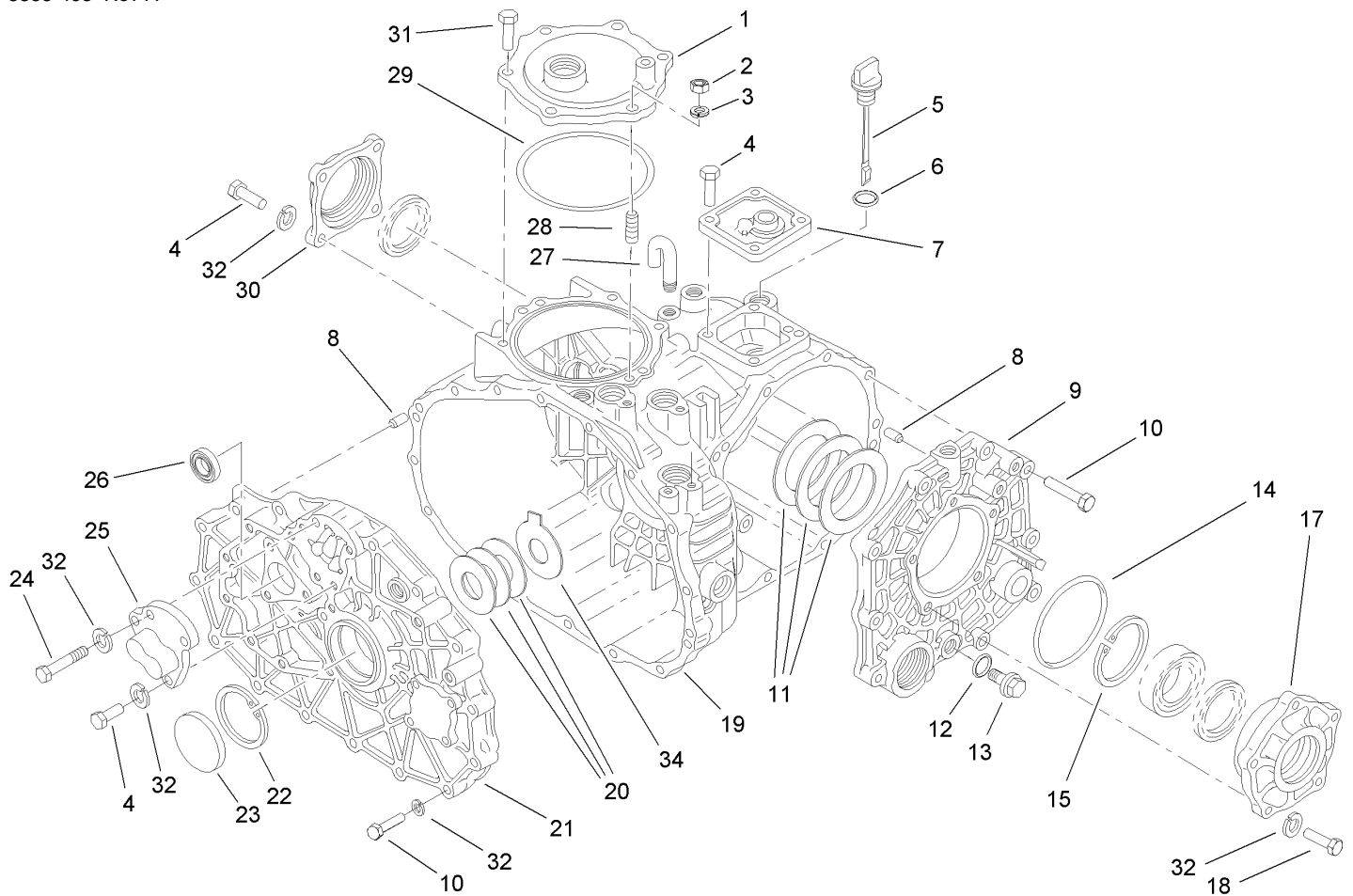

Case Assembly Transaxle Assembly No. 105-4180

Ref	Part No.	Qty.	Description
1	92-0656	1	Cover-Upper, PTO
2	68-9400	1	Nut-Flange
3	92-0762	1	Washer-Spring
4	33114-025	11	Screw-HH
5	92-0662	1	Cap-Oil
6	92-0788	1	O-Ring
7	92-0652	1	Cover-Upper
8	92-0765	4	Pin-Parallel
9	92-0653	1	Cover-Side
10	33114-040	25	Screw-HH
11	92-0809	1	Set-Shim
12	92-0787	1	O-Ring
13	92-0773	1	Plug-Drain
14	92-0789	1	O-Ring
15	92-0760	1	Ring-Snap
17	92-0654	1	Carrier-Differential
18	33114-030	5	Screw-HH
19	92-0651	1	Case-Transmission
20	100-4460	1	Shim Set
21	100-4461	1	Plate-Center
22	92-0759	1	Ring-Snap
23	92-0807	1	Cap-Sealing
24	48-7560	1	Bolt-HH
25	92-0706	1	Shaft-Fork

Ref	Part No.	Qty.	Description
26	92-0791	1	Seal-Oil
27	92-0743	1	Breather-Air
28	92-0804	1	Stud
29	92-0790	1	O-Ring
30	92-0655	1	Cover-Seal, Axle
31	92-0796	5	Bolt
32	3253-4	42	Washer-Lock
34	100-4465	1	Shim (W/Tab)

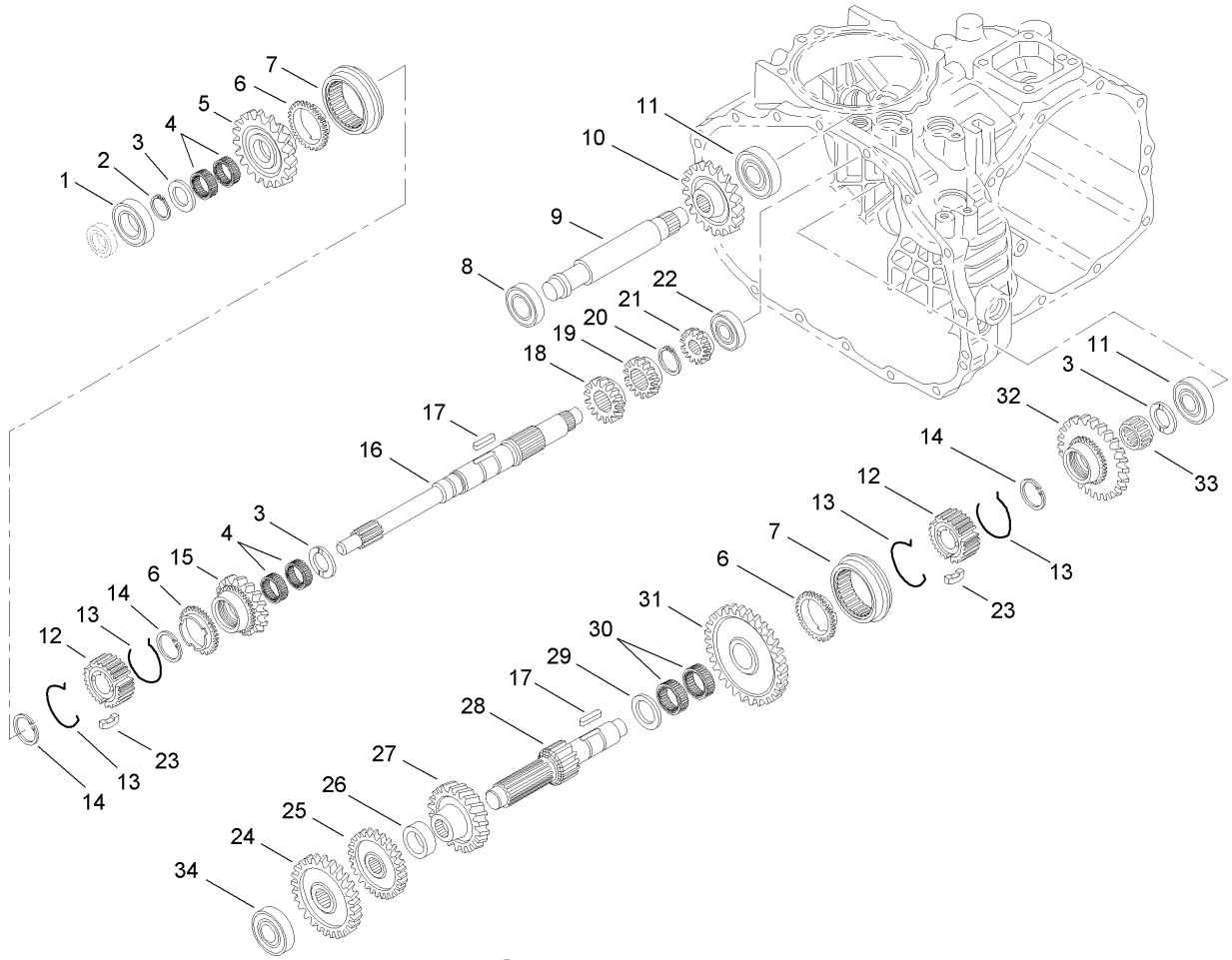

Gear Shaft Assembly Transaxle Assembly No. 105-4180

Ref	Part No.	Qty.	Description
1	251-8	1	Bearing-Ball
2	92-0753	1	Ring-Snap
3	92-0740	3	Washer-Thrust
4	92-0781	4	Bearing-Needle
5	110-2521	1	Gear-Main, 27T
6	92-0667	3	Ring-Synchro
7	92-0668	2	Shifter-Synchro
8	251-346	2	Bearing-Ball
9	92-0824	1	Shaft-Idler, Reverse
10	92-0684	1	Gear-Reverse, 33 Tooth
11	92-0778	2	Bearing
12	92-0664	2	Hub-Synchro
13	92-0666	4	Spring-Synchro
14	92-0763	3	Ring-Snap
15	110-2522	1	Gear- Main, 24T
16	92-0663	1	Shaft-Main
17	92-0772	2	Key
18	92-0687	1	Gear-Main, 16 Tooth
19	92-0672	1	Gear-Main, 18 Tooth
20	92-0754	1	Ring-Snap
21	92-0673	1	Gear-Main, 14 Tooth
22	92-0650	1	Bearing
23	92-0665	6	Key-Synchro
24	92-0822	1	Gear-Reduction, 28 Tooth

Ref	Part No.	Qty.	Description
25	92-0679	1	Gear-Reduction, H23 Tooth
26	92-0680	1	Collar
27	92-0823	1	Gear-Reduction, 43 Tooth
28	92-0674	1	Shaft-Reduction
29	92-0682	1	Washer-Thrust
30	92-0681	2	Bearing-Needle
31	110-2524	1	Gear- Reduction, 49T
32	92-0819	1	Gear-Reduction, 40 Tooth
33	92-0782	1	Bearing-Needle
34	105-7985	1	Bearing

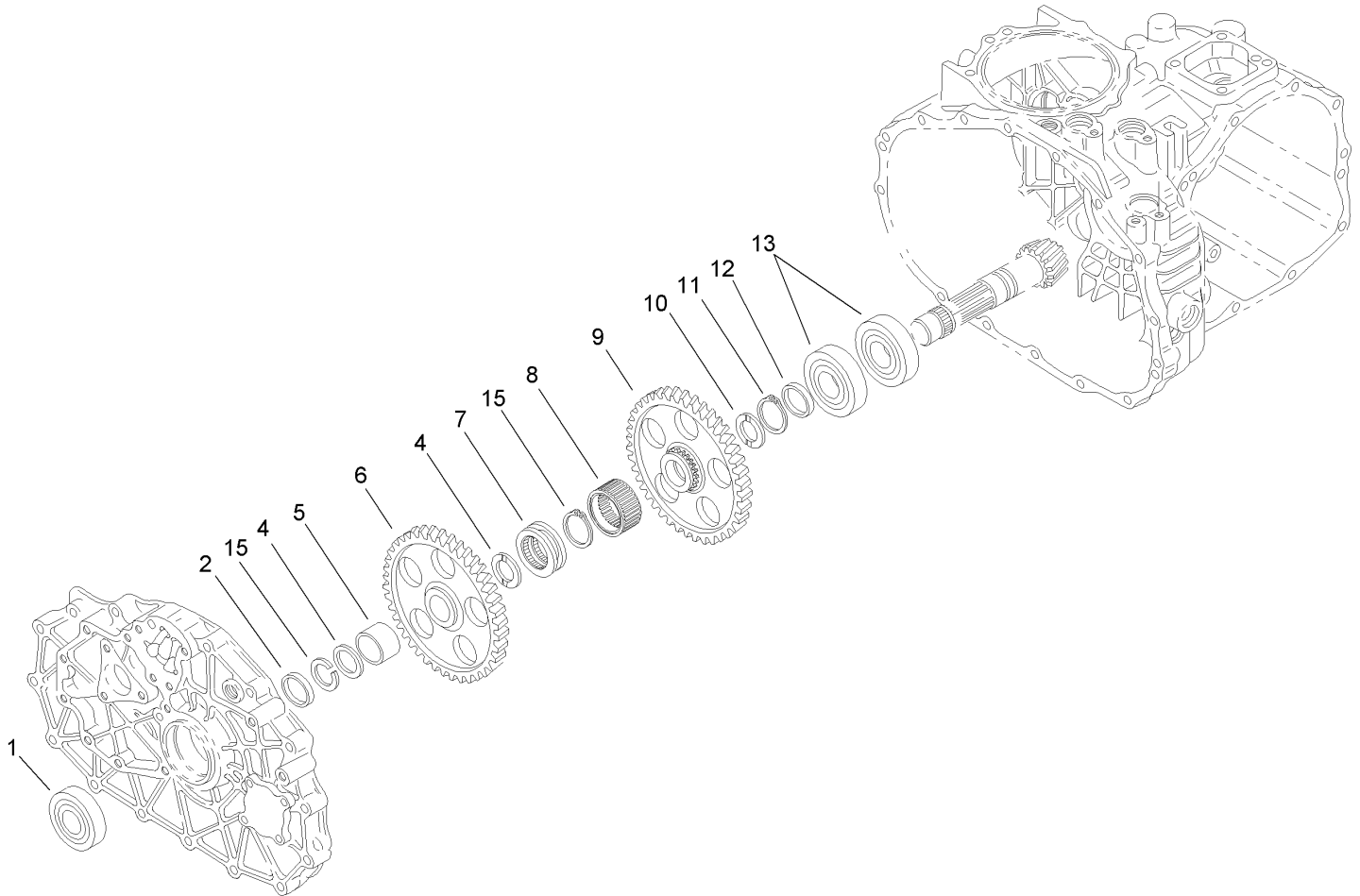

Countershaft Assembly Transaxle Assembly No. 105-4180

Ref	Part No.	Qty.	Description
1	92-0712	1	Bearing-Ball
2	92-0716	1	Collar
4	92-0711	2	Washer-Thrust
5	92-0783	1	Race-Inner
6	92-0715	1	Gear-Shaft, Counter
7	92-0718	1	Shifter
8	105-7986	1	Collar-Spline
9	92-0717	1	Gear-Shaft, Counter
10	92-0741	1	Washer-Thrust
11	92-0755	1	Ring-Snap
12	92-0713	1	Collar
13	92-0714	2	Bearing
15	105-7987	2	Ring-Snap

--	--	--	--

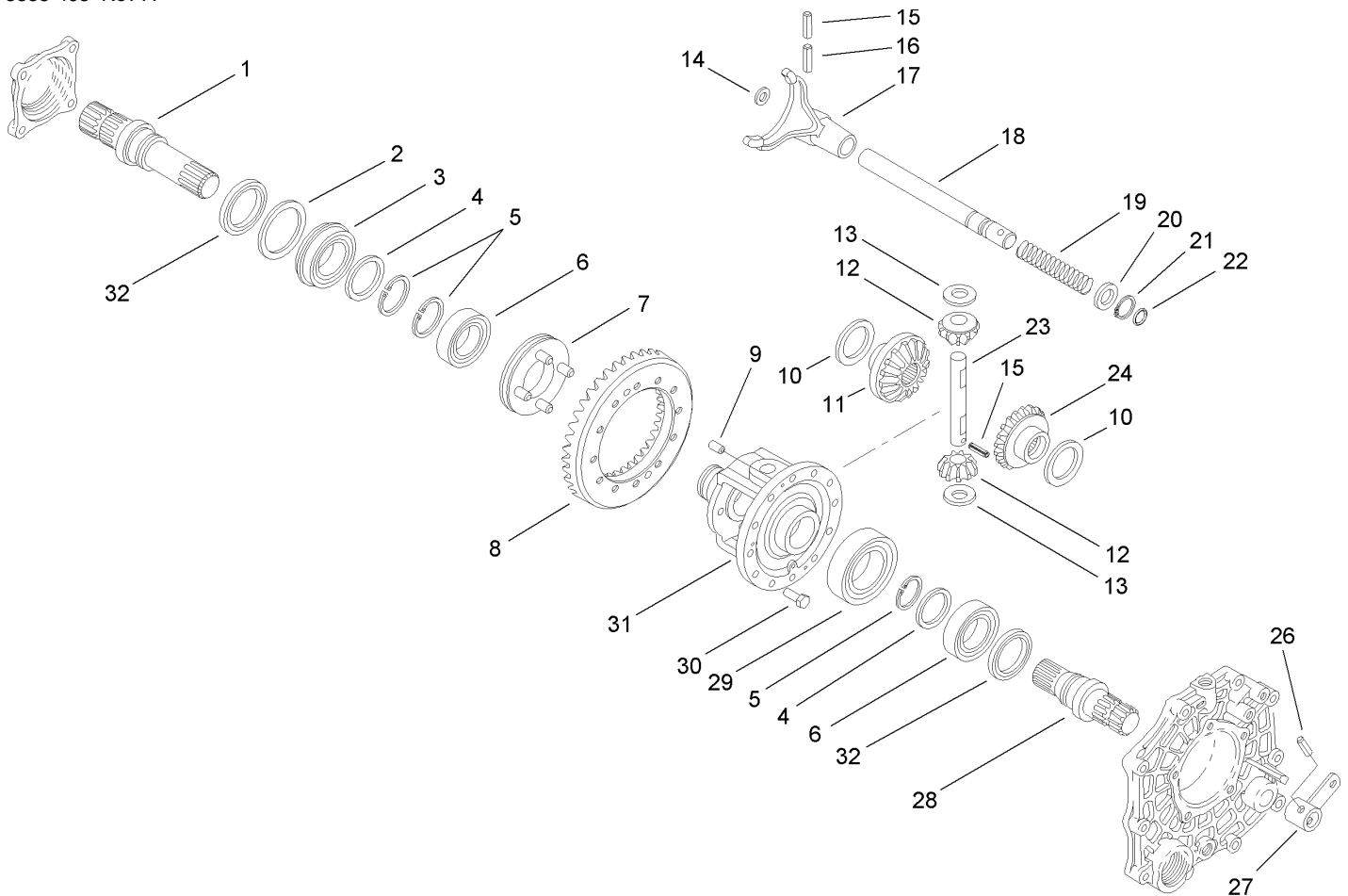

Differential Gear Assembly Transaxle Assembly No. 105-4180

Ref	Part No.	Qty.	Description
1	92-0726	1	Shaft-Axle, Right
2	92-0728	1	Washer
3	92-0780	1	Bearing
4	92-0727	2	Washer
5	92-0756	3	Ring-Snap
6	92-0775	2	Bearing
7	92-0730	1	Slider-Differential, Lock
8	105-7983	1	Countershaft And Ring Gear
9	92-0765	2	Pin-Parallel
10	92-0747	2	Side-Gear, Left Inner
11	92-0746	1	Gear-Side, RH
12	92-0748	2	Pinion-Differential
13	92-0750	2	Washer
14	92-0744	1	Washer
15	92-0768	2	Pin-Roll, Spring
16	92-0771	1	Pin-Roll, Spring
17	92-0721	1	Fork-Lock, Differential
18	92-0722	1	Shaft-Fork, Lock Differential
19	92-0723	1	Spring-Lock, Differential
20	92-0733	1	Washer
21	92-0753	1	Ring-Snap
22	92-0787	1	O-Ring
23	92-0749	1	Shaft-Pinion
24	92-0745	1	Gear-Side, LH

Ref	Part No.	Qty.	Description
26	92-0770	1	Pin-Roll, Spring
27	92-0724	1	Arm-Lock, Differential
28	92-0725	1	Shaft-Axle, Left
29	92-0776	1	Bearing
30	92-0803	12	Bolt
31	92-0720	1	Case-Differential
32	92-0793	2	Seal-Oil

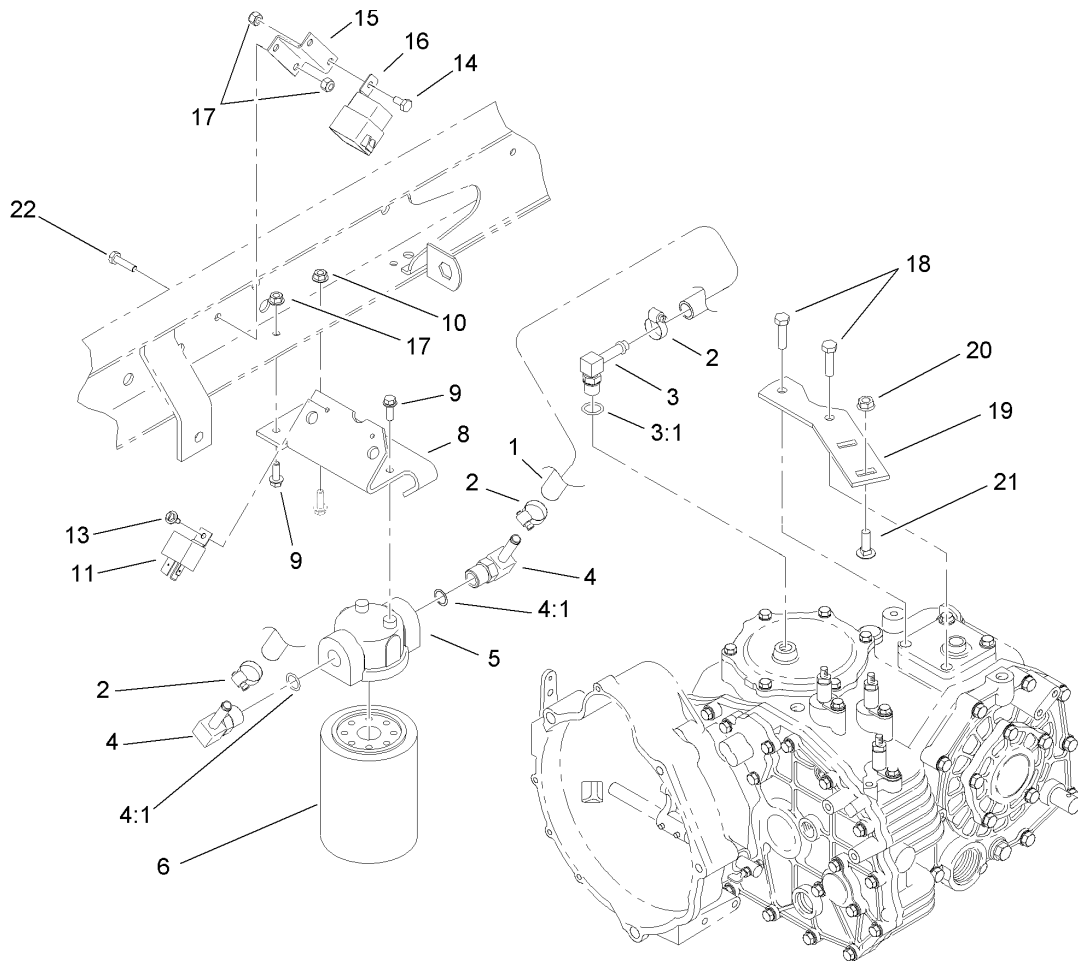

Diesel Hydraulic Filter and Relay Assembly

Ref	Part No.	Qty.	Description
1	87-5730	1	Hose
2	2412-36	3	Clamp-Hose
3	100-4887	1	Fitting-Barb
3:1	237-42	1	O-Ring
4	354-134	2	Fitting-HYD, 90 DEG
4:1	237-79	1	O-Ring
5	87-8780	1	Head-Filter
6	54-0110	1	Filter-Oil, Transmission
8	105-4199	1	Bracket-Mount, Filter
9	3234-4	3	Screw-HHF
10	32128-33	1	Nut-HF
11	99-7435	1	Relay-Power
13	32144-112	1	Screw-HWH
14	321-2	1	Screw-HH
15	105-1776	1	Bracket-Mount, Relay
16	99-7430	1	Relay
17	32128-33	3	Nut-HF
18	33114-030	2	Screw-HH
19	105-9472	1	Plate-Mount, Muffler
20	32128-20	2	Nut-HF
21	3230-2	2	Bolt-CARR
22	321-4	2	Screw-HH

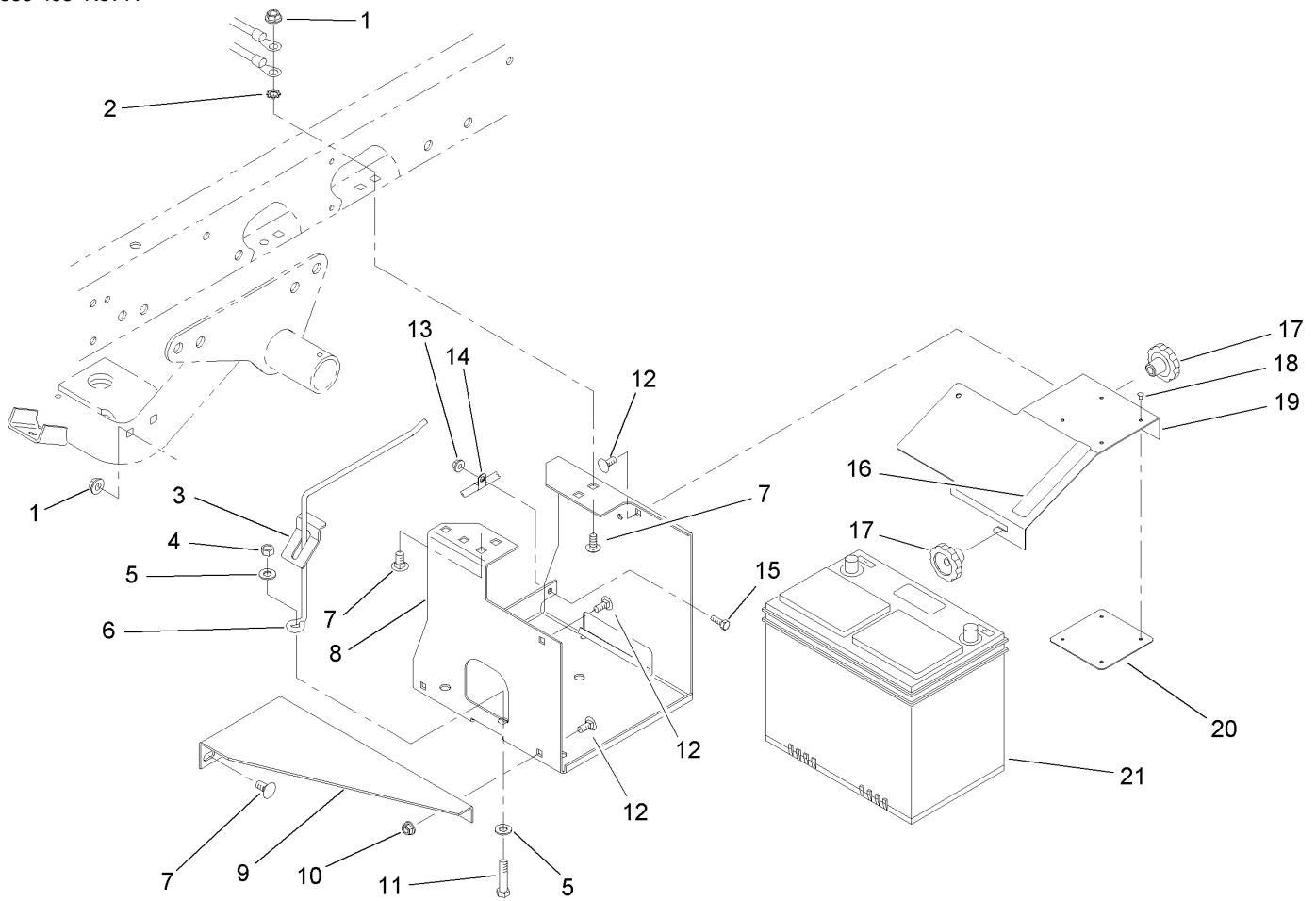

Battery Assembly

Ref	Part No.	Qty.	Description
1	3290-357	6	Nut-HHF, Whiz
2	3255-9	1	Washer-Lock
3	87-7610	1	Tab-Support, Battery
4	3296-39	1	Nut-Lock, NI
5	3256-24	2	Washer-Flat
6	87-7600	1	Rod-Support, Battery
7	3231-27	6	Screw-CARR
8	87-5120-03	1	Bracket-Holder, Battery
9	87-5110-03	1	Support-Base, Battery
10	32128-20	2	Nut-HF
11	323-9	1	Screw-HH
12	3230-23	4	Screw-CARR
13	32128-33	1	Nut-HF
14	2412-89	1	Clamp
15	321-4	1	Screw-HH
16	93-6687	1	Decal-No Step
17	19-4050	2	Knob
18	3269-27	4	Rivet-Snap
19	87-5130-03	1	Cover-Battery
20	87-7620	1	Shield-Terminal, Battery
21	106-5190	1	Battery

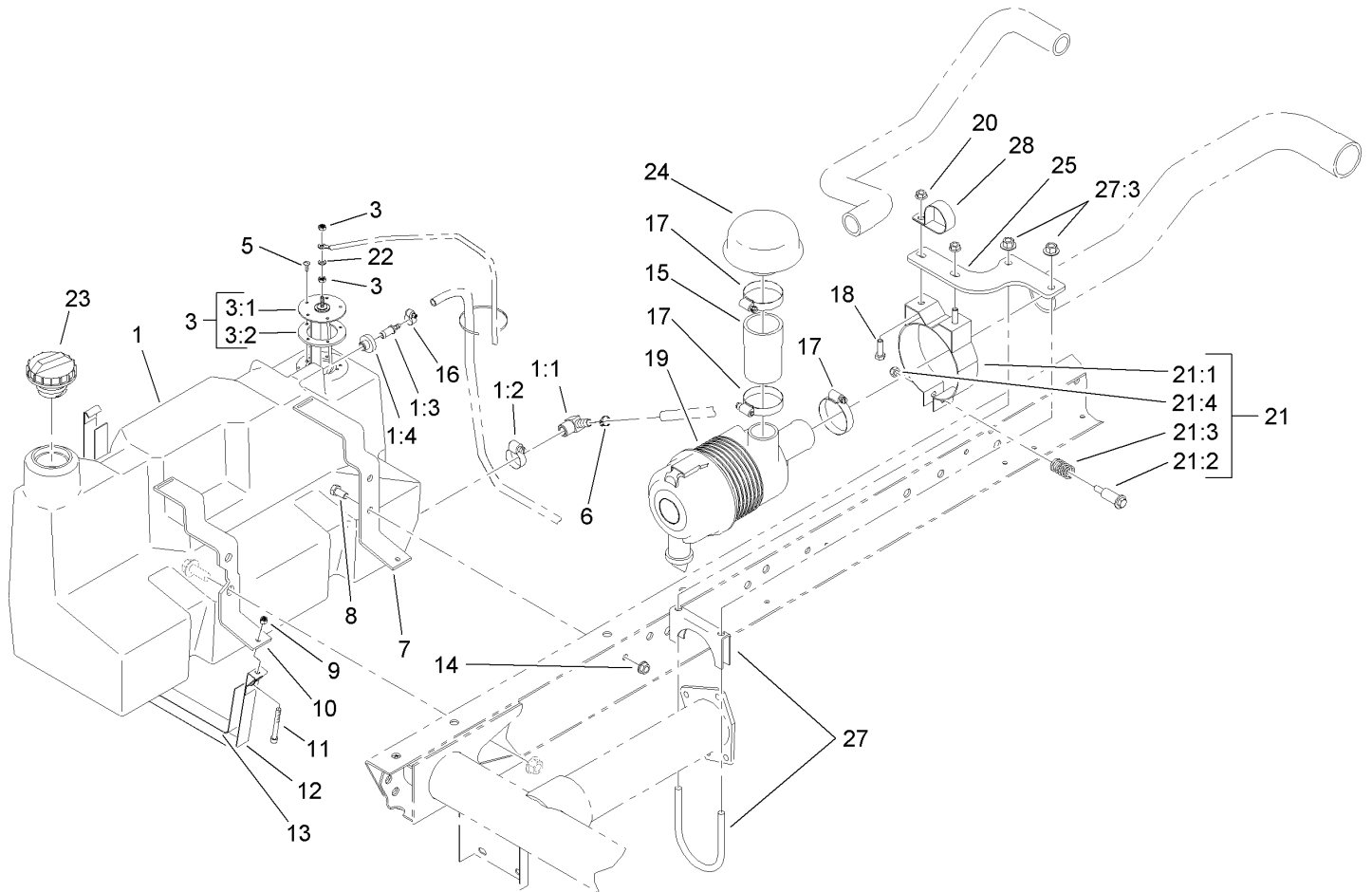

Diesel Fuel Tank and Air Cleaner Assembly

Ref	Part No.	Qty.	Description
1	98-2915	1	Tank-Fuel
1:1	353-781	1	Fitting-Elbow
1:2	2412-36	1	Clamp-Hose
1:3	98-2952	1	Fitting-Straight
1:4	46-6560	1	Bushing
3	112-3170	1	Fuel Sender ASM
●3:1		1	Sender-Fuel
3:2	62-7650	1	Gasket
5	112-3169	5	Screw-HHF, Serrated
6	92-2379	1	Clamp-Hose
7	87-3140-03	1	Support-Gas Tank, Rear
8	323-4	2	Screw-HH
9	3296-42	2	Nut-Lock, NI
10	87-3150-03	1	Support-Gas Tank, Front
11	3274-54	2	Screw-HSH
12	87-3160	2	Strap-Tank, Gas
13	87-3170	2	Felt-Strap
14	3290-357	2	Nut-HHF, Whiz
15	107-7962	1	Hose-Cleaner, Air
16	2412-108	1	Clamp-Worm
17	2412-92	3	Clamp-Hose
18	322-5	2	Screw-HH
19	106-2416	1	Aircleaner ASM
20	32128-20	2	Nut-HF

Ref	Part No.	Qty.	Description
21	93-2191	1	Band-Mounting, Air Cleaner
●21:1		1	Clamp ASM
21:2	94-3653	1	Bolt
21:3	94-3654	1	Spring
21:4	48-9510	1	Nut
22	5-3637	1	Spacer
23	93-3102	1	Cap-Fuel
24	46-7510	1	Hood-Inlet, Air
25	106-7948-03	1	Bracket-Mount
27	107-7954	1	Clamp-Muffler
27:3	32128-43	2	Nut-Flange
28	2412-147	1	Clamp

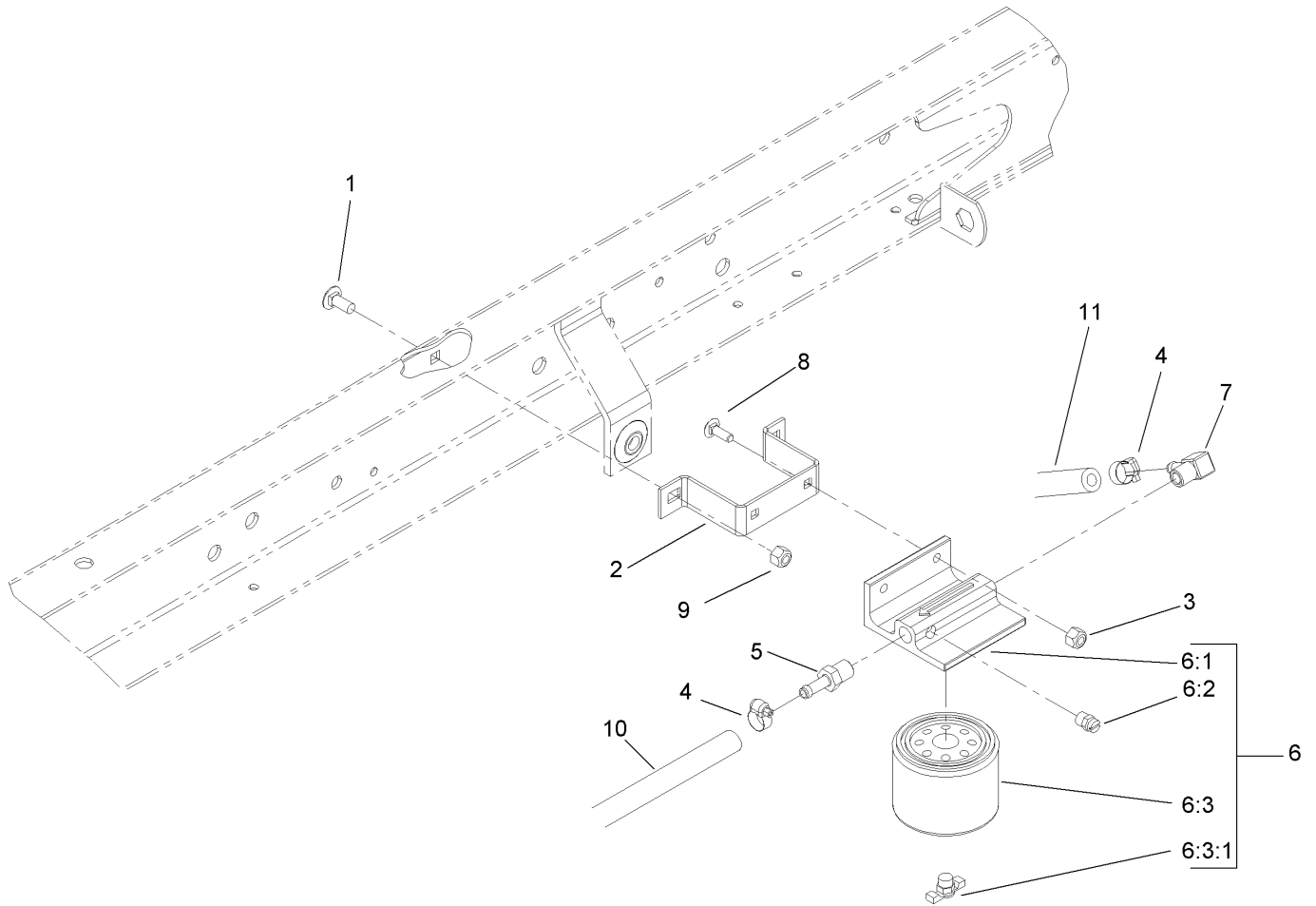

Diesel Filter Assembly

Ref	Part No.	Qty.	Description
1	3230-23	2	Screw-CARR
2	105-4202	1	Bracket-Mount, Filter
3	3296-42	2	Nut-Lock, NI
4	2412-108	2	Clamp-Worm
5	353-783	1	Fitting-Straight
6	63-7650	1	Separator-Filter / Water
6:1	63-8280	1	Head ASM
6:2	63-8290	1	Vent-Air
6:3	63-8300	1	Element-Spin On
6:3:1	63-8310	1	Valve-Drain
7	353-707	1	Fitting-HYD, 90 DEG
8	3229-25	2	Screw-CARR
9	3296-29	2	Nut-Lock, NI
10	110-4104	1	Hose-Fuel
11	109-0309	1	Hose-Fuel

--	--	--	--

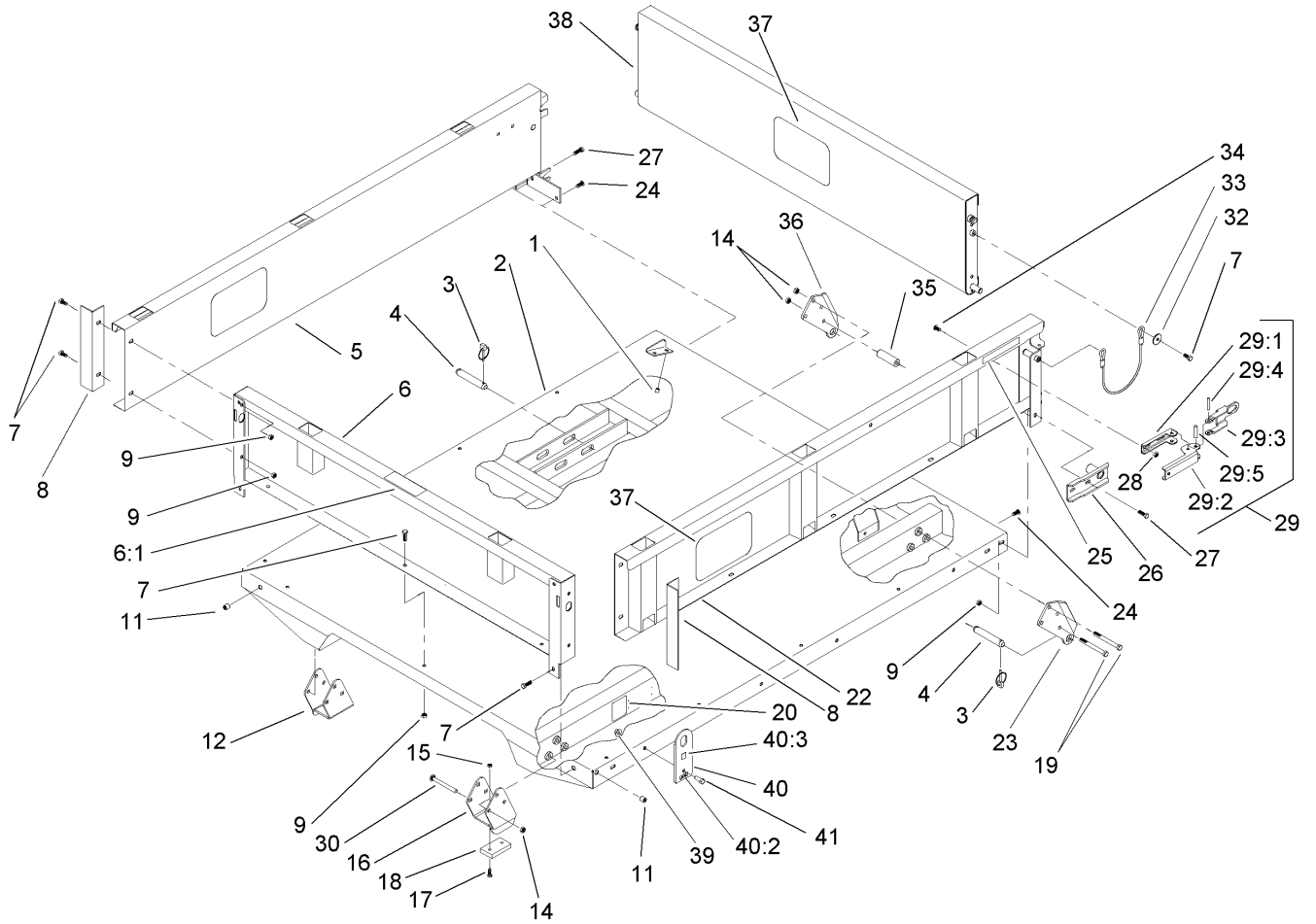

Full Bed and Side Panel Assembly

Ref	Part No.	Qty.	Description
1	32148-6	4	Insert-Nut
2	93-9724-03	1	Flatbed-Full
3	92-1298	8	Pin-Lynch
4	92-1233	4	Pin-Clevis
5	92-1255-03	1	RH Side Panel ASM
6	92-5982	1	Front Panel ASM
6:1	93-6689	1	Decal-No Riders
7	3234-7	21	Screw-HHF
8	92-1320-03	2	Angle-Side
9	104-8300	23	Nut-Flange, NI
11	32148-7	4	Nut-Insert
12	106-2423-03	1	RH Spacer Bracket ASM
14	3296-44	14	Nut-Lock, NI
15	3296-42	4	Nut-Lock, NI
16	106-2422-03	1	LH Spacer Bracket ASM
17	3250-45	4	Screw-SPH
18	93-9719	2	Block-Wear
19	323-42	8	Screw-HH
20	93-9899	2	Decal-Warning
22	92-1248-03	1	LH Side Panel ASM
23	93-9720-03	2	Bracket-Pivot, Long (LH)
24	3230-1	2	Bolt-CARR
25	93-9868	2	Decal-Caution
26	92-1265-03	2	Bracket-Pivot

Ref	Part No.	Qty.	Description
27	3234-29	6	Screw-HHF
28	32128-20	4	Nut-HF
29	99-1123	2	Latch ASM
29:1	92-1271	1	Pivot-Latch
29:2	99-1113	1	Handle-Latch
29:3	99-1112	1	Plate-Retainer
29:4	32121-78	1	Pin-Roll
29:5	32121-25	1	Pin-Roll
30	3231-24	6	Screw-CARR
32	3256-57	4	Washer-Flat
33	93-9595	2	Lanyard
34	3230-15	4	Screw-CARR
35	93-9575	2	Tube-Pivot, Flatbed
36	93-9721-03	2	Bracket-Pivot, Long (RH)
37	105-4222	3	Decal
38	92-1259-03	1	Tailgate-Rear
39	32128-43	4	Nut-Flange
40	106-6733	4	Lift Plate ASM
40:2	93-9525	1	Decal
40:3	93-9084	1	Decal-Point, Lift
41	323-6	4	Screw-HH

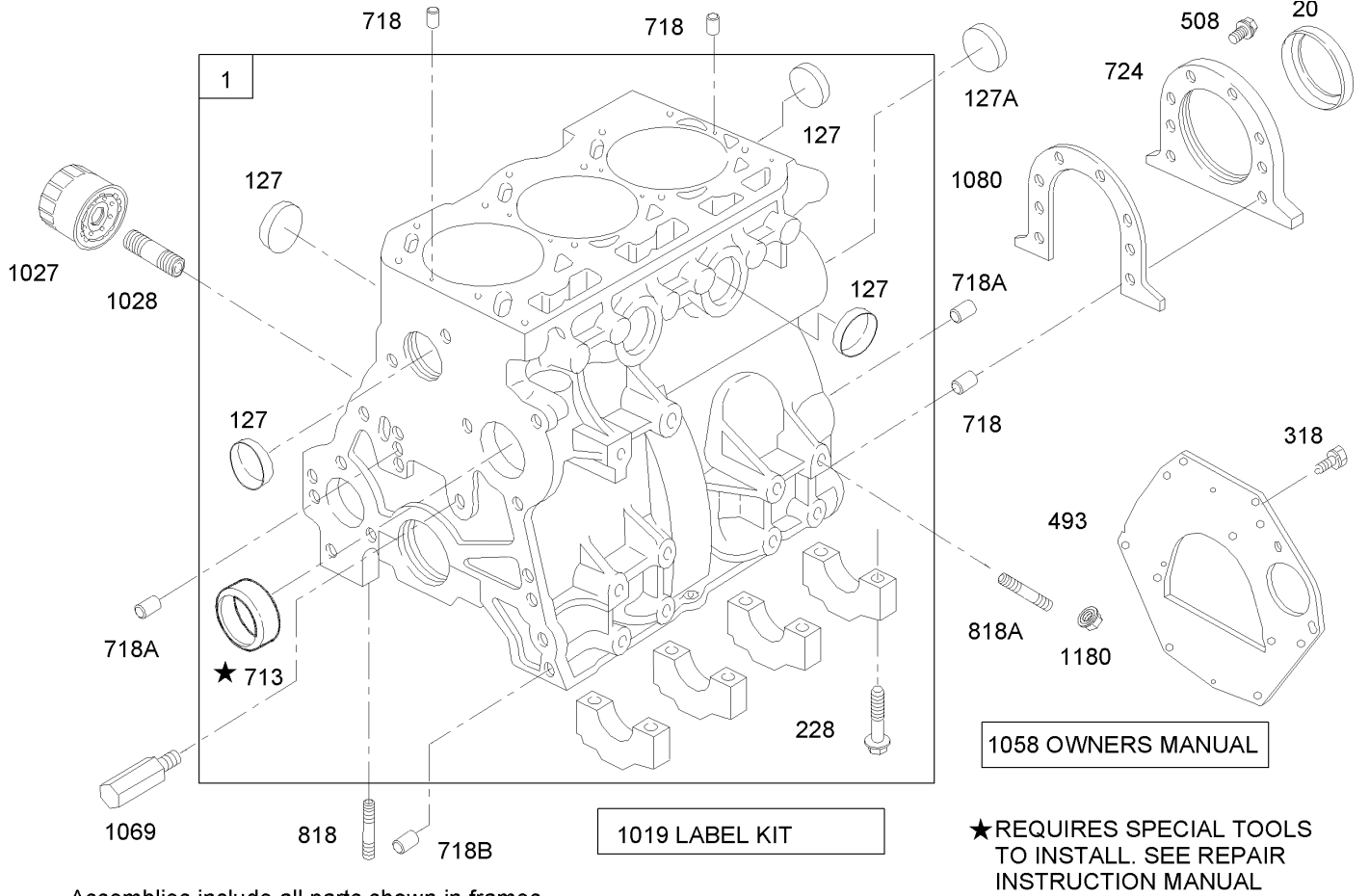

Cylinder Assembly

Ref	Part No.	Qty.	Description
1	107-9891	1	Cylinder ASM
20	99-9003	1	Seal-Oil
127	99-9008	1	Plug-Welch
228	99-9006	1	Screw-Hex
318	99-9005	1	Screw-Hex
493	104-9232	1	Plate-End, Rear
508	99-9004	1	Screw-Hex
713	99-9002	1	Bushing
718	99-9012	1	Pin-Locating
724	99-9022	1	Retainer-Seal
818	99-9007	1	Stud-Metric
1019	110-2595	1	Label Kit
1027	108-3842	1	Filter-Oil
1028	105-9337	1	Adapter-Filter, Oil
1058	99-9602	1	Manual-Owner's
1069	99-9020	1	Nozzle-Oil
1080	99-9021	1	Gasket-Retainer
1180	99-9176	1	Nut-Hex
127A	107-9892	1	Plug-Welch (Cam)
718A	99-9013	1	Pin-Locating
718B	99-9014	1	Pin-Locating
818A	99-9221	1	Stud-Standard

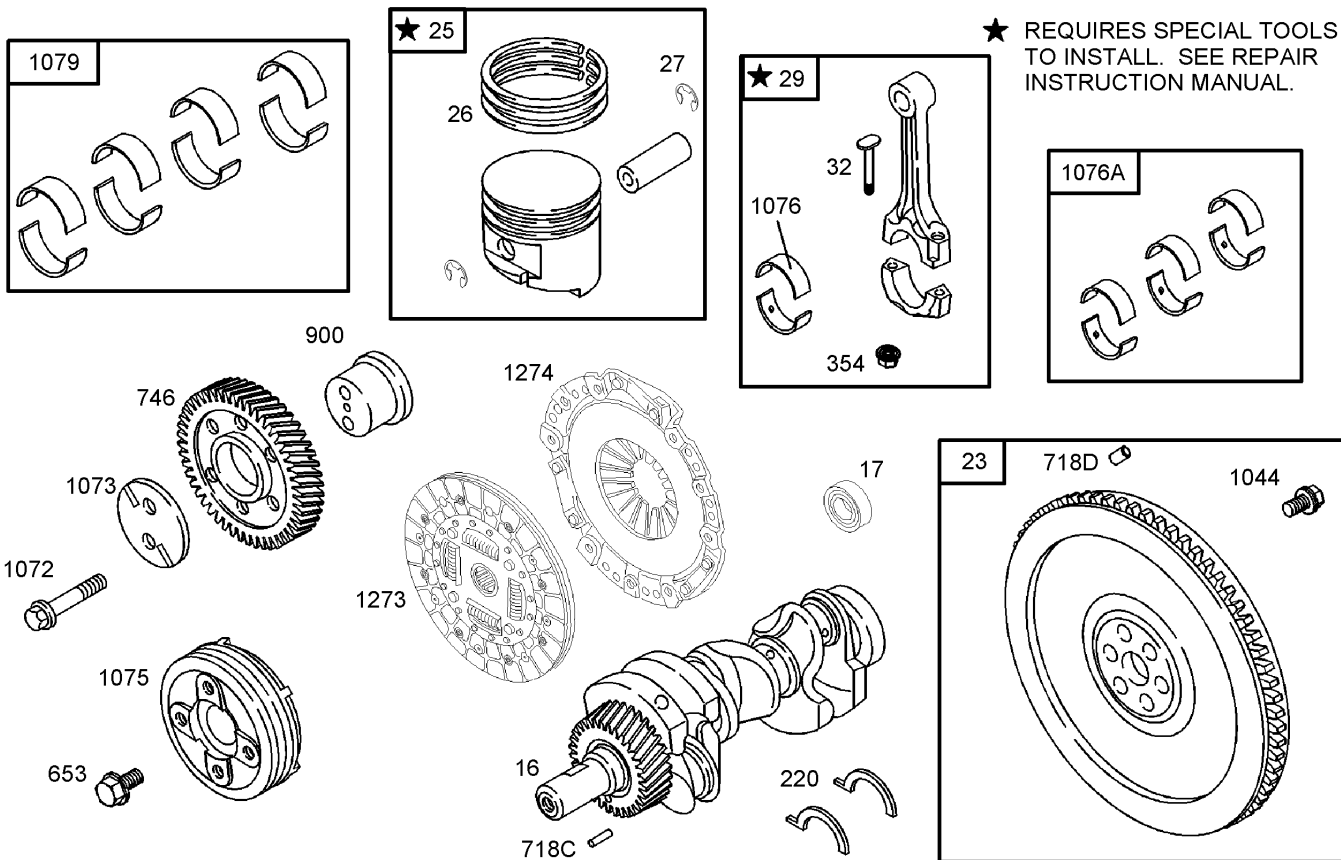

Assemblies include all parts shown in frame in frames.

Crankshaft Assembly

Ref	Part No.	Qty.	Description
16	105-9339	1	Crankshaft
17	105-9324	1	Bearing-Ball, Radial
23	105-9323	1	Flywheel ASM
25	107-9895	1	Piston ASM
25	107-9896	1	Piston ASM (Oversize)
26	105-9340	1	Ring Set
26	99-9269	1	Ring Set (.010 In Oversized)
27	99-9607	1	Lock-Pin, Piston
29	99-9608	1	Rod-Connecting
32	99-9030	1	Screw-Rod, Connecting
220	99-9035	1	Washer-Thrust
220	99-9036	1	Washer-Thrust (.005 In Oversized)
354	99-9034	1	Nut-Hex
653	107-9897	1	Screw-Hex
746	99-9609	1	Gear-Drive
900	99-9039	1	Shaft-Gear
1044	99-9031	1	Screw-Hex
1072	99-9032	1	Screw-Hex
1073	99-9040	1	Plate-Gear, Idler
1075	99-9041	1	Pulley-Crankshaft
1076	99-9042	1	Bearing-Rod
1079	99-9045	1	Set-Bearing, Main (Set Of 8)

Ref	Part No.	Qty.	Description
1079	99-9046	1	Set-Bearing, Main (.010 Undersized)
1273	104-9219	1	Disc-Clutch
1274	104-9231	1	Plate-Pressure, Clutch
718C	99-9037	1	Pin-Locating
718D	106-1852	1	Pin-Locating
1076A	99-9043	1	Set-Bearing, Rod
1076A	99-9044	1	Set-Bearing, Rod (.010 Undersized)

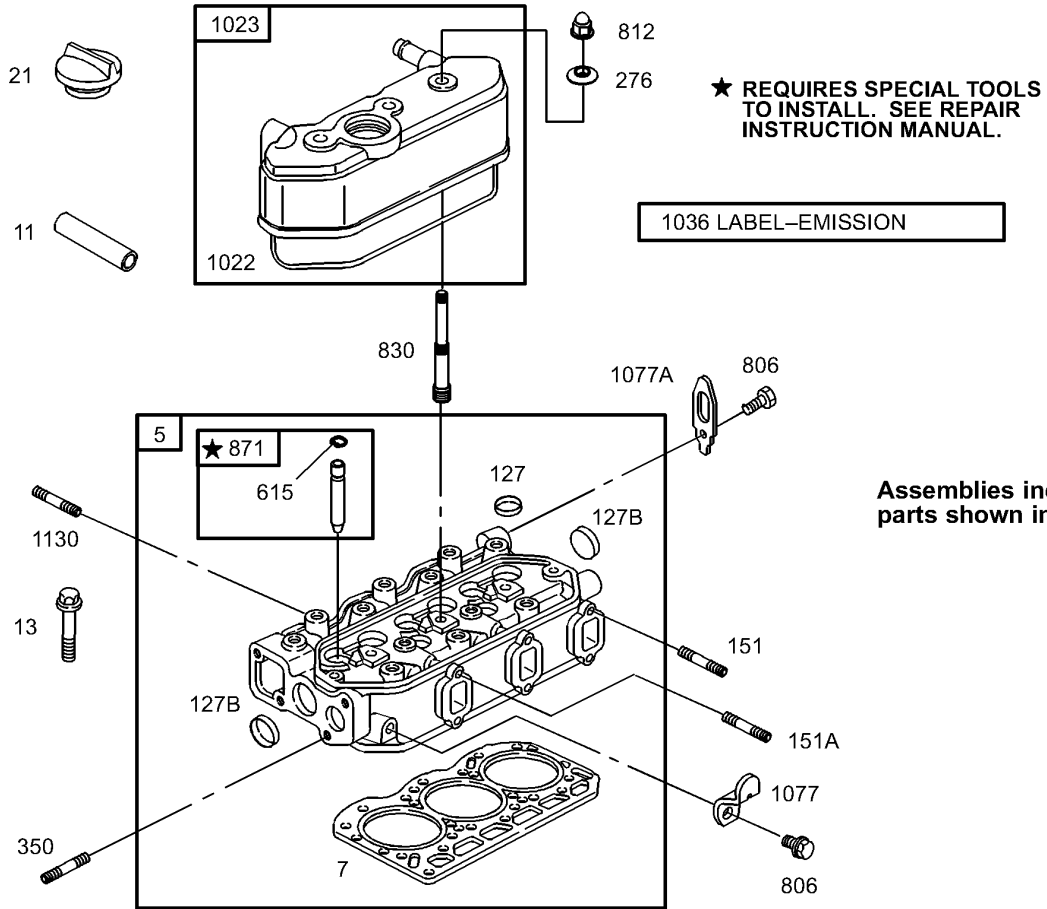

Cylinder Head Assembly

Ref	Part No.	Qty.	Description
5	110-2596	1	Head-Cylinder
7	107-9898	1	Gasket-Head, Cylinder
11	105-9342	1	Tube-Breather
13	99-9614	1	Screw-Metric
21	99-9052	1	Cap-Fill, Oil
127	99-9060	1	Plug-Welch
151	99-9058	1	Stud-Metric
276	99-9063	1	Washer-Seal
350	99-9057	1	Stud-Metric
615	99-9067	1	Retainer
806	99-9054	1	Screw-Hex
812	99-9061	1	Nut-Hex, Metric
830	99-9101	1	Stud-Arm, Rocker
871	99-9070	1	Bushing-Guide
1022	99-9073	1	Gasket-Cover, Rocker
1023	100-6402	1	Cover-Rocker
1036	99-9615	1	Emission Label Kit
1077	99-9076	1	Bracket-Lifting
1130	99-9055	1	Stud-Metric
127B	99-9008	1	Plug-Welch
151A	99-9059	1	Stud-Metric
1077A	99-9077	1	Bracket-Lifting

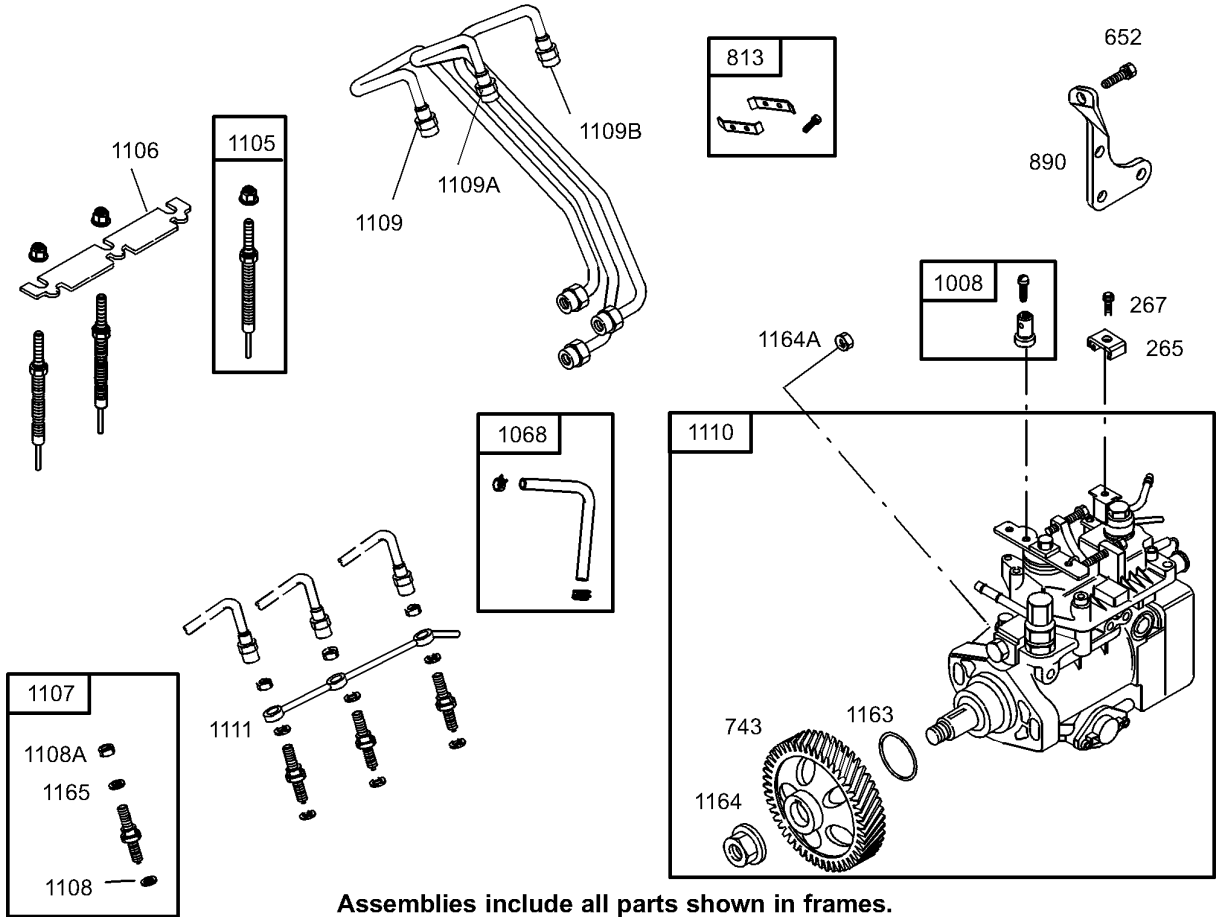

Injection Pump Assembly

Ref	Part No.	Qty.	Description
265	99-9688	1	Clamp-Casing
267	100-6403	1	Screw-Metric
652	99-9616	1	Screw-Hex
743	99-9624	1	Gear-Drive
813	99-9625	1	Clamp
890	99-9626	1	Bracket-Support
1008	99-9628	1	Clamp-Swivel
1068	99-9629	1	Hose / Clamp ASM
1105	99-9630	1	Plug-Glow
1106	99-9631	1	Strap-Plug, Glow
1107	99-9632	1	Nozzle-Injector
1108	99-9633	1	Seat-Injector
1109	99-9690	1	Pipe-Injector, No. 1
1110	105-9334	1	Pump-Injection
1111	99-9637	1	Pipe-Return, Fuel
1163	99-9618	1	O-Ring
1164	99-9619	1	Nut-Hex, Metric
1165	105-9345	1	Nut
1108A	105-9343	1	Seat-Injector
1109A	99-9634	1	Pipe-Injector, No. 2
1109B	99-9635	1	Pipe-Injector, No. 3
1164A	99-9620	1	Nut-Hex, Metric

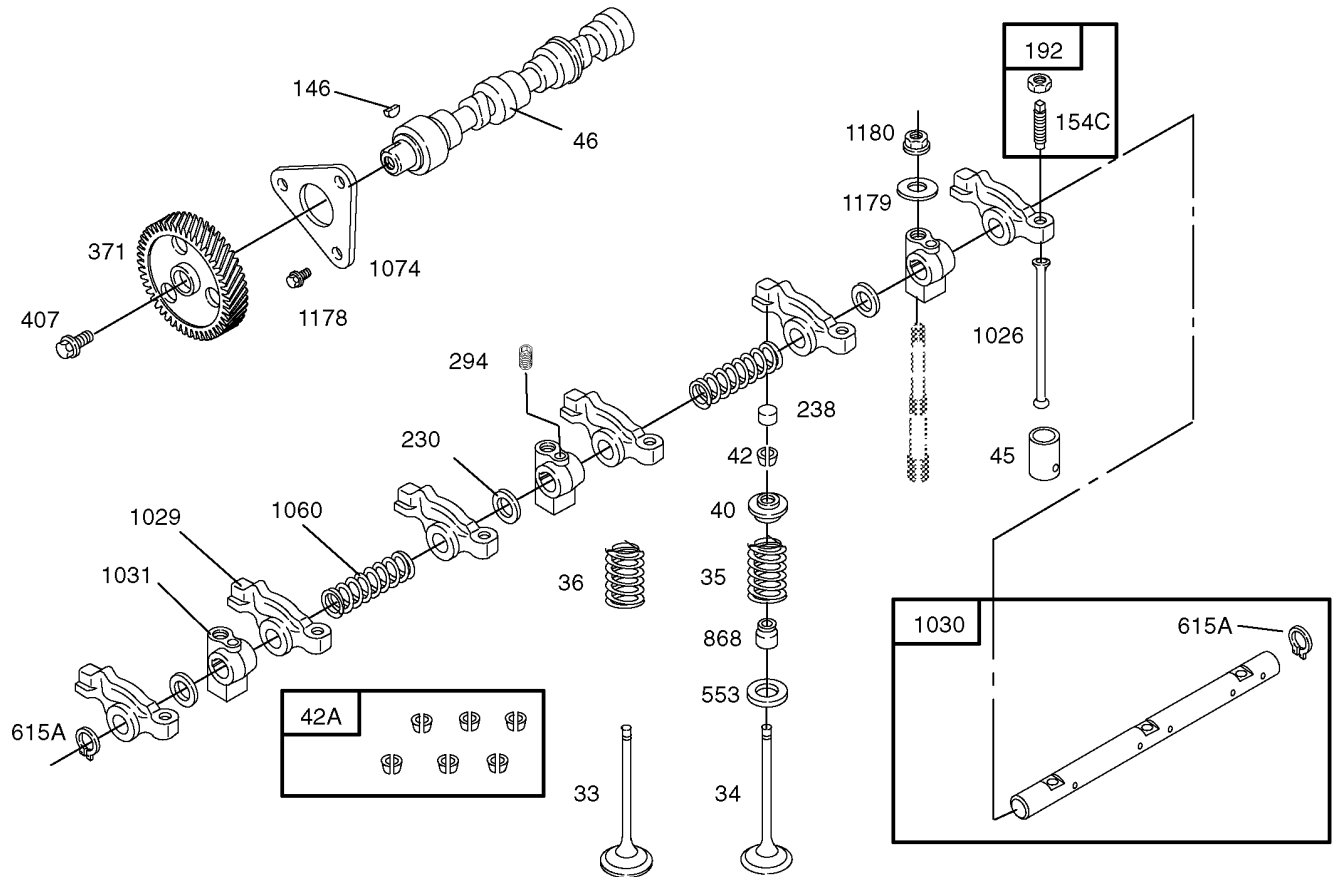

Assemblies include all parts shown in frames.

Camshaft Assembly

Ref	Part No.	Qty.	Description
33	99-9638	1	Valve-Exhaust
34	99-9639	1	Valve-Intake
35	99-9640	1	Spring-Valve
36	99-9640	1	Spring-Valve
40	99-9084	1	Retainer-Valve
42	99-9086	1	Keeper-Valve (Set)
45	99-9088	1	Tappet-Valve
46	99-9097	1	Shaft-Cam
146	99-9675	1	Key-Timing
192	112-2978	1	Adjuster-Rocker Arm
230	99-9093	1	Washer-Spacer
238	112-2979	1	Cap-Valve
294	99-9090	1	Screw-Metric
371	99-9641	1	Gear-Cam
407	99-9085	1	Screw-Metric
42A	99-9087	1	Keeper-Valve (Set Of 6)
553	99-9096	1	Seat-Spring, Valve
868	99-9643	1	Seal-Valve
1026	112-2980	1	Rod-Push
1029	99-9104	1	Arm-Rocker
1030	99-9106	1	Shaft-Arm, Rocker
1031	99-9107	1	Support-Arm, Rocker
1060	99-9108	1	Spring-Shaft, Rocker
1074	99-9109	1	Retainer-Camshaft

Ref	Part No.	Qty.	Description
1178	99-9083	1	Screw-Hex
1179	99-9079	1	Washer-Flat
1180	99-9091	1	Nut-Hex, Metric
154C	99-9091	1	Nut-Hex, Metric
615A	99-9099	1	Retainer

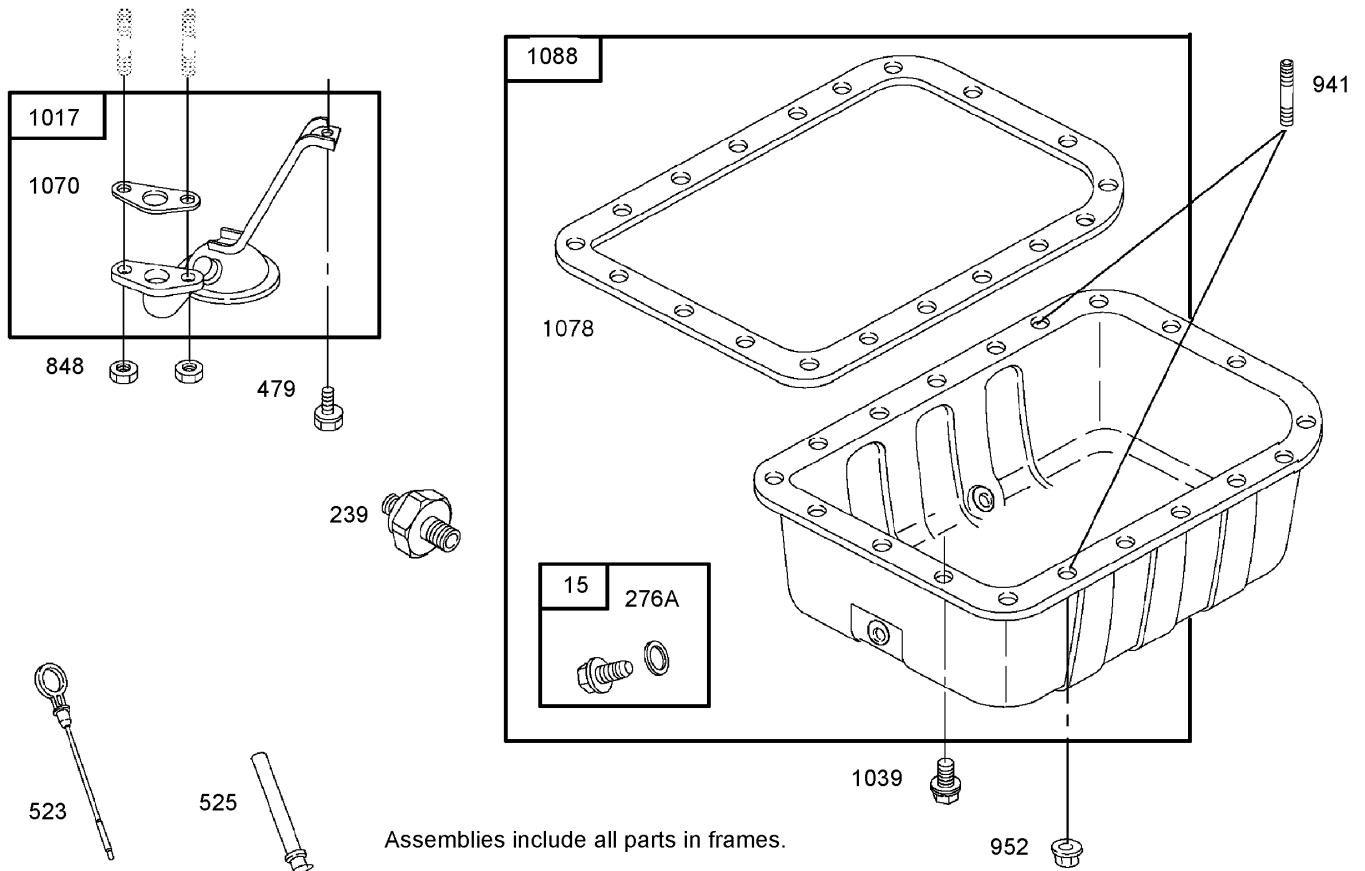

Assemblies include all parts in frames.

Oil Pan Assembly

Ref	Part No.	Qty.	Description
15	99-9247	1	Plug-Drain, Oil
239	107-9908	1	Switch-Pressure, Oil
479	99-9111	1	Screw-Hex
523	110-2597	1	Dipstick
525	99-9118	1	Tube-Dipstick
848	99-9114	1	Nut-Hex, Metric
941	99-9112	1	Stud-Metric
952	99-9113	1	Nut-Hex, Metric
1017	99-9116	1	Screen-Pump, Oil
1039	99-9623	1	Screw-Hex
1070	99-9120	1	Gasket-Strainer, Oil
1078	99-9121	1	Gasket-Pan, Oil
1088	99-9241	1	Pan-Oil
276A	99-9249	1	Washer-Seal

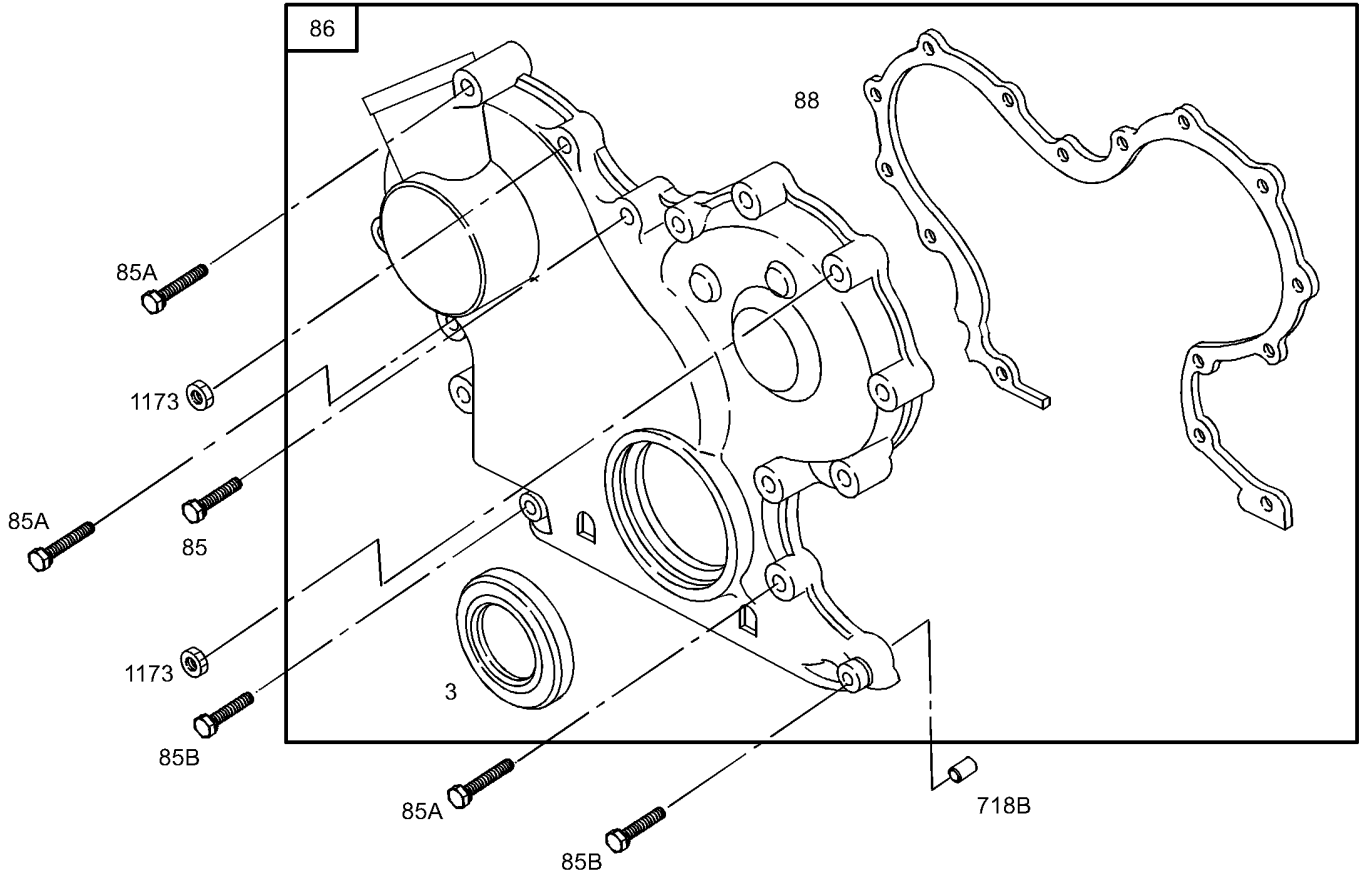

Assemblies include all parts shown in frames.

Gear Cover Assembly

Ref	Part No.	Qty.	Description
3	107-9900	1	Seal-Oil
85	99-9651	1	Screw-Hex
86	99-9652	1	Gear Cover ASM
88	99-9653	1	Gasket-Cover, Gear
85A	99-9128	1	Screw-Hex
85B	99-9129	1	Screw-Hex
1173	99-9114	1	Nut-Hex, Metric
718B	99-9014	1	Pin-Locating

--	--	--	--

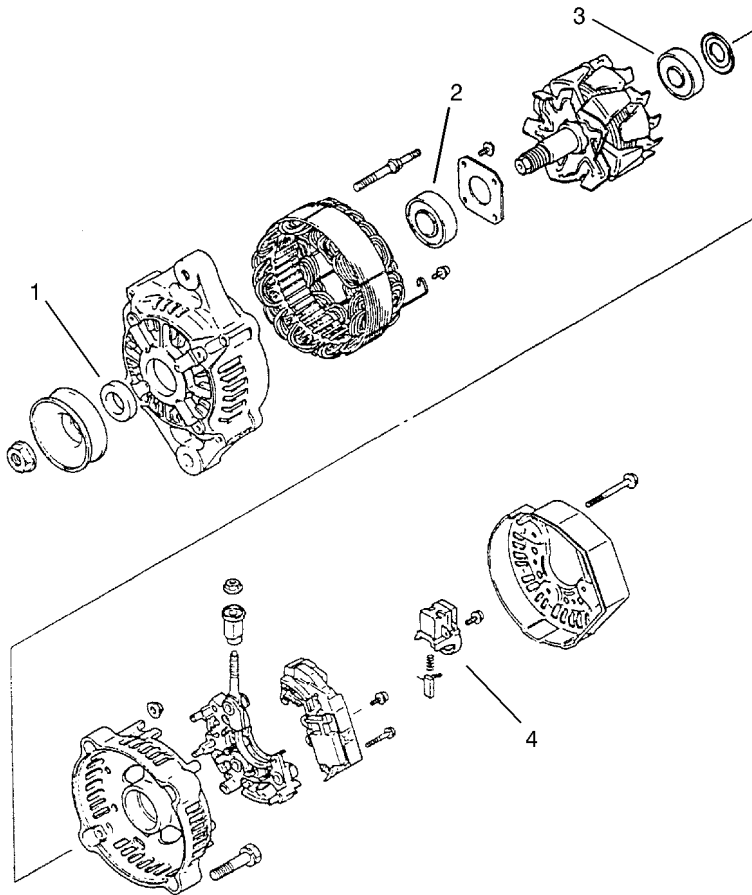

Parts not listed in part list are not serviced separately

Alternator Assembly No. 99-9209

Ref	Part No.	Qty.	Description
1	100-5315	1	Collar
2	100-5316	1	Bearing
3	100-5317	1	Bearing
4	100-5318	1	Brush Holder ASM

--	--	--	--

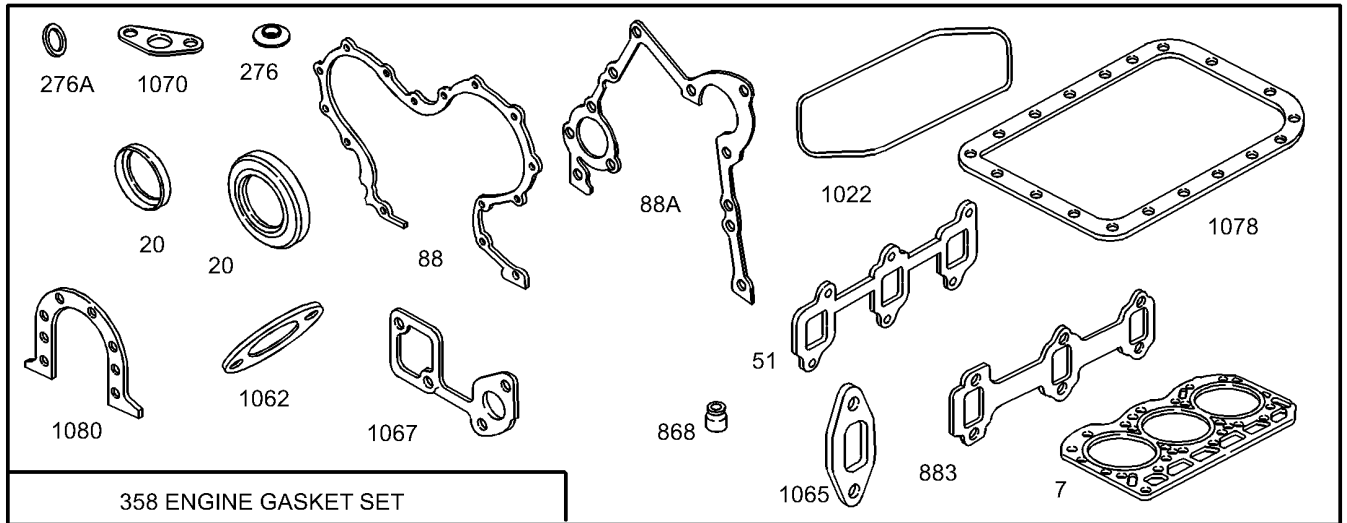

358 ENGINE GASKET SET

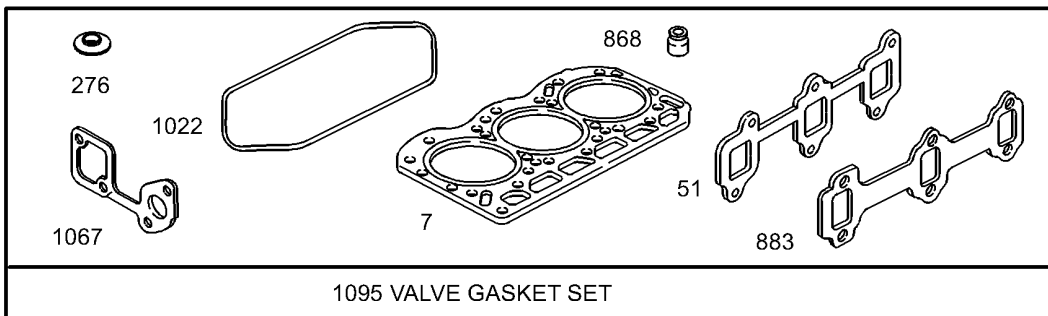

1095 VALVE GASKET SET

Assemblies include all parts shown in frames.

Gasket Assembly

Ref	Part No.	Qty.	Description
7	107-9898	1	Gasket-Head, Cylinder
20	99-9003	1	Seal-Oil
20	107-9900	1	Seal-Oil
51	99-9662	1	Gasket-Intake
88	99-9653	1	Gasket-Cover, Gear
276	99-9063	1	Washer-Seal
358	107-9906	1	Gasket Set
868	99-9643	1	Seal-Valve
883	106-1855	1	Gasket-Exhaust
88A	99-9136	1	Gasket-Cover, Gear
1022	99-9073	1	Gasket-Cover, Rocker
1062	99-9163	1	Gasket-Outlet
1065	99-9166	1	Gasket-Housing, Inlet
1067	99-9021	1	Gasket-Retainer
1070	99-9120	1	Gasket-Strainer, Oil
1078	99-9121	1	Gasket-Pan, Oil
1080	99-9021	1	Gasket-Retainer
1095	107-9907	1	Valve Overhaul Kit
276A	99-9645	1	Washer-Seal

--	--	--	--

Attachments and Accessories

For 07362TC - Workman 3300-D with Bed

Product Name	Model/Part
High-Flow Hydraulic Kit	07228
Full Area Flatbed	07301
Full Area Flatbed Side Kit	07302
Fold Down Side Kit	07303
Cab Kit with Doors	07319
2/3 Area Flatbed	07321
2/3 Area Flatbed Side Kit	07322
Heater Kit	07330
Bed Liner	07331
Sunshade Kit	07332
Fold-down Windshield Kit	07333
1/3 Area Flatbed	07341
1/3 Area Stake Side Kit	07342
1/3 Area Platform Lift	07344
Rear PTO Kit	07419
Hand Throttle Kit	07420
Cap-Diesel, Green	107-2172
Tachometer Kit	107-7976
Signal Light Kit	107-7985
Accessory Wire Harness Kit	107-7987
Work Light Kit	107-7988
High Air Intake Kit	107-8003
Remote Hydraulics Float Kit	107-8004
Backup Alarm Kit	107-8037
Side Mirror Kit	107-8048
Premium Engine Oil, 10w30 (Drum)	108-1179
Premium Engine Oil, 10w30 (Pail)	108-1180
Premium ATF Drum	108-1185
Premium ATF Pail	108-1186
Premium All Purpose Grease	108-1190
Arrestor-Spark	108-3108
Mirror Kit	110-2510
Single Nozzle Kit	41024
Hose Reel Kit	41097
Spray Gun Kit	41133
Pro Foam Concentrate (4 X 1 Gallon)	41157
Foam Marker Kit	41228
Workman 200 Spray System	41235
Spreader Base Unit	41253
Vicon Spreader	41256
Enclosed Boom	41355
Enclosed Walking Boom	41358
Enclosed Walking Boom Trailer	41359
Enclosed Boom Mount	41363
Power Holster Hitch Kit	44209
Drawbar Kit	44212
Hitch Frame and Draw Bar Kit	44213
Topdresser 1800	44225
Fifth Wheel Hitch Kit	44230
Core Harvester Adapter Kit	44242
1/3 Area Tool Box Mounting Kit	92-1219
Automatic Tailgate Release Kit	92-1220

Attachments and Accessories (continued)

For 07362TC - Workman 3300-D with Bed

Product Name	Model/Part
Block-Fuse	92-2641
PTO Over Running Clutch Kit	92-2655
Topdresser 1800 Lift Kit	92-4452
Mid-Mount Kit for Platform Lift	93-3741
1/3 Area Cover Kit	93-9225
Rear 1/3 Area Mounting Kit	93-9249

NOTES

NOTES

NOTES

