



Workman[®] 3100 with Bed

Model No. 07363 - 270000701 and up.

Parts Catalog

Ordering Replacement Parts

To order replacement parts, please supply the part number, the quantity, and the description of each part desired.

Understanding Reference Numbers

Each Identified part in an illustration has a reference number. The reference number for a part also appears in the parts list, along with other information about the part.

This catalog uses two special reference number formats, one to indicate parts in a service assembly and another to indicate the quantity of a given part in an illustration.

Service Assembly Reference Numbers

Parts in service assemblies have reference numbers in the form a:b. The a represents the reference number of the entire service assembly and the b represents a sequential number unique to each part within the service assembly.

For example, a wheel assembly might be identified by reference number 6, the tire by 6:1, the valve by 6:2, and the wheel by 6:3. When you order the assembly identified by reference number 6, you receive all parts identified by reference numbers 6:1, 6:2, and 6:3. However, you may also order any part individually. Reference numbers of this type appear in illustrations and in part lists.

Reference Numbers Indicating Quantity

In an illustration, if a reference number indicates more than one part, the reference number has the form nX y. The n represents the quantity of the part, the X is the multiplication symbol, and the y represents the reference number.

For example, in an illustration, the reference number 2X 37 means that two of the parts identified by reference number 37 are indicated.

Contents

Description	Page	Description	Page
Hood and Bumper Assembly 4	Gear Shaft Assembly Transaxle Assembly No. 105-4180 39
Dash Panel Assembly 5	Countershaft Assembly Transaxle Assembly No. 105-4180 40
Steering Assembly 6	Shift Fork Assembly Transaxle Assembly No. 105-4180 41
Steering Pump Assembly No. 106-6726 8	Differential Gear Assembly Transaxle Assembly No. 105-4180 42
Hydraulic Cylinder Assembly No. 106-2262 9	Hydraulic Filter and Relay Assembly 43
Brake Accelerator and Clutch Assembly 10	Battery Assembly 44
Master Cylinder Assembly No. 104-6782 11	Fuel Tank Assembly 45
Hydraulic Brake Assembly 12	Engine Assembly 46
Clutch Linkage Assembly 13	Full Bed and Side Panel Assembly 47
Shroud and Seat Assembly 14	Muffler and Relay Assembly 48
LH Seat Assembly 15	Engine Support Assembly 49
RH Seat Assembly 16	Crankshaft Assembly Kohler CH23-76548 50
Roll-Over Protection System Assembly 17	Crankcase Assembly Kohler CH23-76548 51
Front Wheel Assembly 18	Oil Pan / Lubrication Assembly Kohler CH23-76548 52
RH Front Brake Assembly No. 87-9170 19	Head / Valve / Breather Assembly Kohler CH23-76548 53
LH Front Brake Assembly No. 87-9180 20	Ignition / Electrical Assembly Kohler CH23-76548 54
Console Assembly 21	Blower Housing and Baffle Assembly Kohler CH23-76548 55
Shift Assembly No. 106-7887 23	Starting System Assembly Kohler CH23-76548 56
Front Suspension Assembly 24	Fuel System Assembly Kohler CH23-76548 57
Front Control Arm Assembly 25	Engine Control Assembly Kohler CH23-76548 58
Lift Valve and Hydraulic Assembly 26	Air Intake / Filtration Assembly Kohler CH23-76548 59
Control Valve Assembly No. 43-1950 28	Exhaust Assembly Kohler CH23-76548 60
Hydraulic Cylinder Assembly No. 106-7939 29	Attachments and Accessories List 61
Hydraulic Pump Assembly No. 106-6649 30		
Rear Frame Assembly 31		
Rear Axle Assembly 32		
LH Rear Brake Assembly No. 93-7126 33		
RH Rear Brake Assembly No. 93-7125 34		
Driveshaft Assembly No. 98-2918 35		
Tail Light and Fender Assembly 36		
Transaxle Assembly 37		
Case Assembly Transaxle Assembly No. 105-4180 38		

Part Description Abbreviations

Part descriptions in this catalog may include the following abbreviations.

AR.	as required	HYD.	hydraulic
ASM.	assembly	LH.	left hand
BBC.	blade brake clutch	NI.	nylon insert
CARR.	carriage	NPTF.	national pipe thread fine
DEG.	degrees	PFH.	phillips flat head
EXT.	external	PPH.	phillips pan head
FH.	flat head	PPHTF.	phillips pan head thread forming
GA.	gauge	PRH.	phillips round head
HD.	heavy-duty	PTH.	phillips truss head
HF.	hex flange	PTO.	power-take-off
HH.	hex head	RH.	right hand
HHF.	hex head flange	ROPS.	roll-over protection system
HHFTF.	hex head flange thread forming	SFH.	slotted fillister head
HJ.	hex jam	SHH.	slotted hex head
HLH.	hex lag head	SHWH.	slotted hex washer head
HOC.	height-of-cut	SPH.	slotted pan head
HSBH.	hex socket button head	SQH.	square head
HSFH.	hex socket flat head	SRH.	slotted round head
HSH.	hex socket head	STD.	standard
HWH.	hex washer head	TAP.	self tapping
HWHTF.	hex washer head thread forming	TTH.	torx truss head

Footnotes

- ❶ Not illustrated
- ❷ Not serviced separately
- ❸ Obtain parts from your local Kohler dealer.

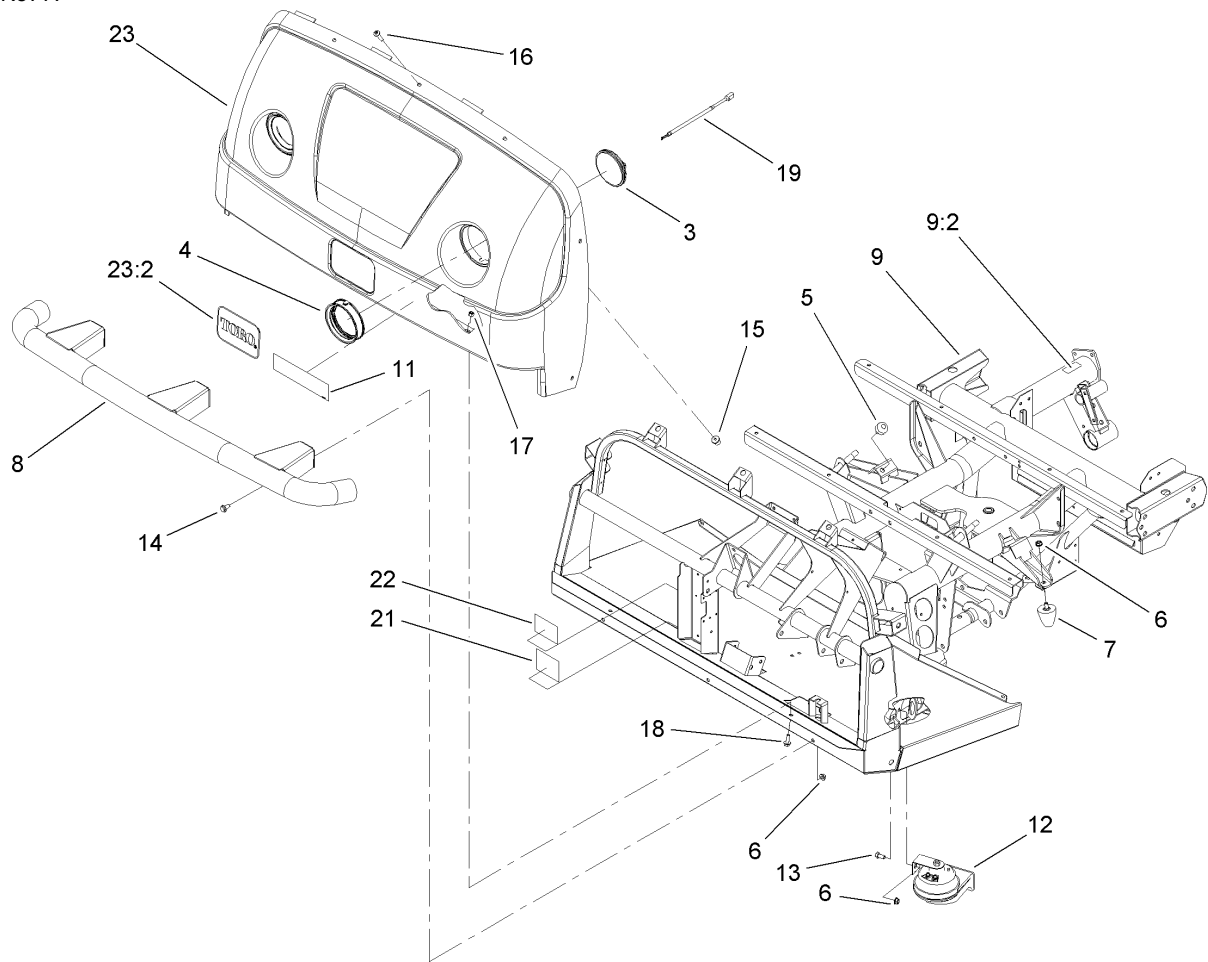

Hood and Bumper Assembly

Ref	Part No.	Qty.	Description
3	99-7310	2	Headlight
4	99-7311	2	Mount-Headlight
5	87-2440	2	Bumper-Rubber
6	3290-357	9	Nut-HHF, Whiz
7	26-0071	2	Snubber-Rubber
8	106-2369-03	1	Bumper ASM
9	106-7884	1	Operator Frame ASM
9:2	93-7814	1	Decal-Danger
11	106-2393	1	Decal-Workman
12	110-2594	1	Horn ASM
13	323-4	1	Screw-HH
14	3234-1	6	Screw-HHF
15	106-7883	7	Nut-Well
16	106-7922	7	Screw-PTH
17	3296-29	2	Nut-Lock, NI
18	3234-29	2	Screw-HHF
19	106-2401	2	Harness-Headlight
21	106-7894	1	Decal-Block, Fuse
22	106-7897	1	Decal-Load Rating, Ac
23	107-7979	1	Front Hood ASM
23:2	62-5550	1	Decal

--	--	--	--

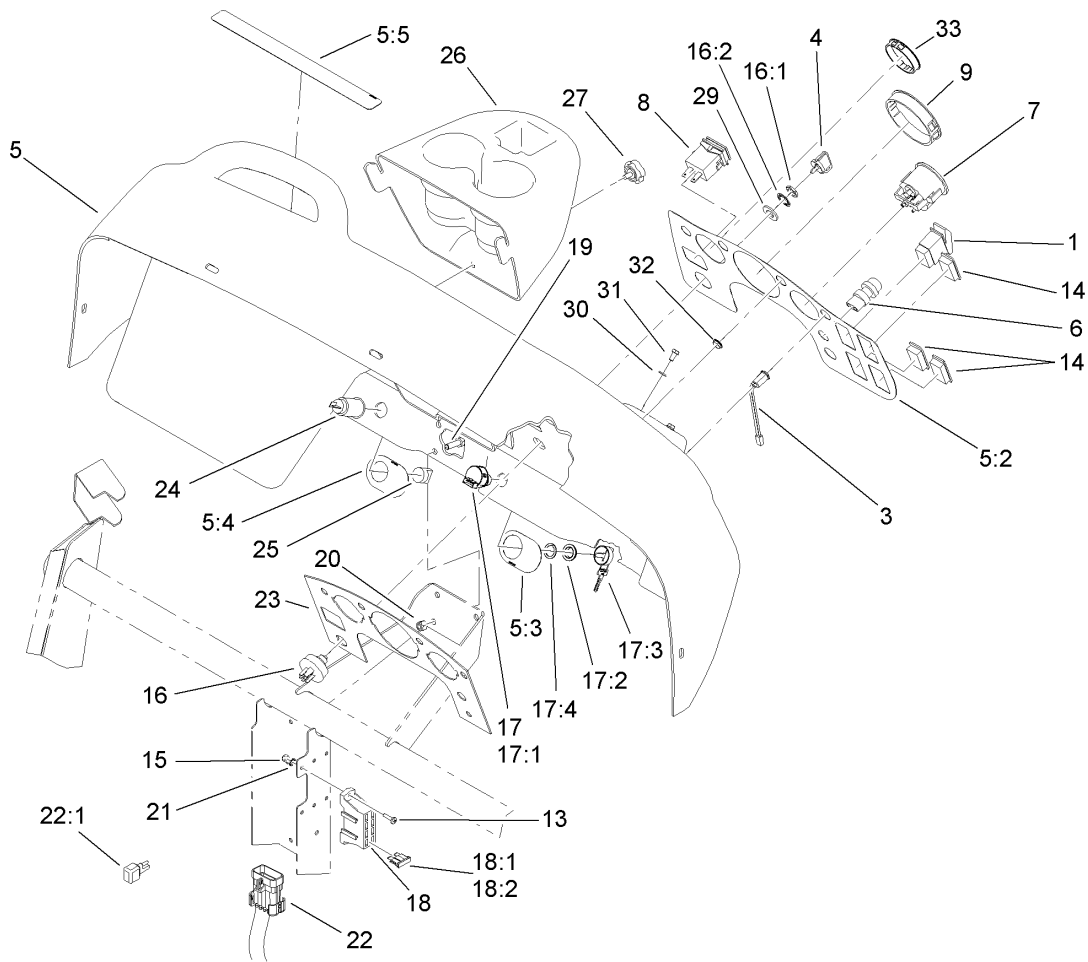

Dash Panel Assembly

Ref	Part No.	Qty.	Description
1	95-8999	1	Switch
3	95-7652	1	Light-Indicator
4	63-8360	2	Key-Ignition
5	112-3040	1	Dash ASM
5:2	106-2352	1	Decal-Dash
5:3	106-2355	1	Decal-Switch, Supervisor
5:4	106-2353	1	Decal-Powerpoint
5:5	110-2599	1	Decal-Warning, Dash
6	18-2830	1	Button-Horn
7	106-2405	1	Gauge-Fuel
8	94-4208	1	Hourmeter
9	106-2359	1	Plug-Cap
13	32105-13	2	Screw-SHH
14	99-7420	3	Plug-Hole
15	3296-2	2	Nut-Lock
16	27-2360	1	Switch-Key
16:1	218-446	1	Nut-Hex
16:2	218-447	1	Washer-Lock
17	110-2580	1	Switch-Key, Supervisor
17:1		1	Switch-Key
17:2	108-8660	1	Nut-Mounting
17:3	110-5221	1	Set-Key, Supervisor
17:4	108-8659	1	Washer-Backup
18	112-3526	1	Harness-Wire, Front

Ref	Part No.	Qty.	Description
18:1	218-578	2	Fuse-10 Amp
18:2	109355	2	Fuse-15 Amp
19	322-3	3	Screw-HH
20	3296-29	3	Nut-Lock, NI
21	3255-10	1	Washer-Lock / EXT
22	112-3510	1	Harness-Wire
22:1	100-4918	1	Diode
23	106-2360-03	1	Plate-Dash
24	99-7411	1	Point-Power
25	99-7416	1	Cap
26	106-2358	1	Cover-Reservoir
27	105-1406	1	Knob
29	9202624	1	Washer
30	33093-00	2	Washer-Flat
31	33113-012	2	Screw-HH
32	2410-64	3	Plug-Button
33	87-8360	1	Plug-Hole, Dash

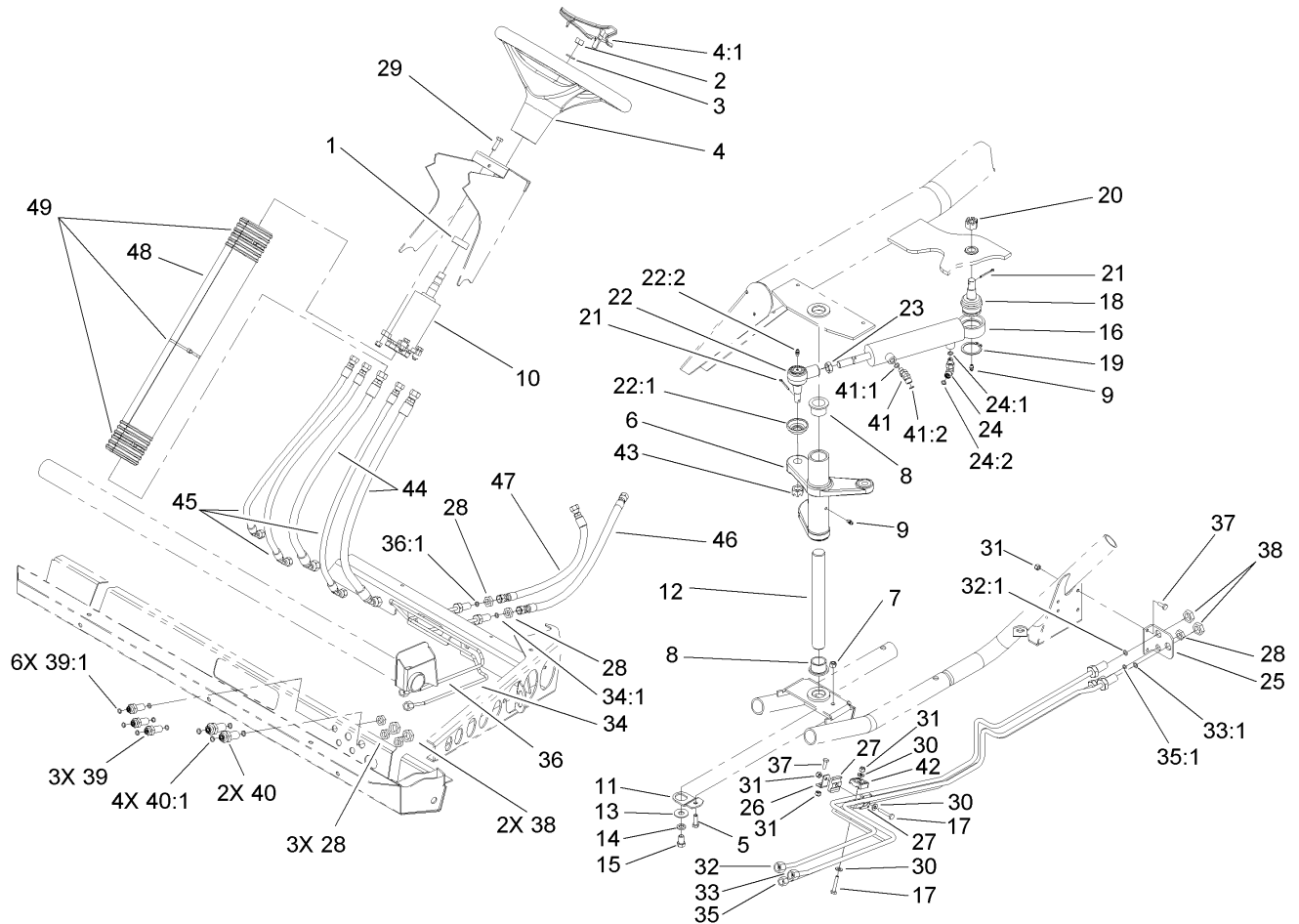

Steering Assembly

Ref	Part No.	Qty.	Description
1	21-9260	1	Cover-Dust
2	3296-33	1	Nut-Lock, NI
3	3256-27	1	Washer-Flat
4	98-1471	1	Wheel-Steering
4:1	98-1468	1	Cover-Wheel, Steering
5	322-5	1	Screw-HH
6	106-2536	1	Arm-Pitman
7	3296-29	1	Nut-Lock, NI
8	94-1291	2	Bushing
9	302-5	2	Fitting-Grease
10	106-6726	1	Steering Pump ASM
11	106-2287	1	Plate
12	106-2271	1	Shaft-Pivot
13	3256-5	1	Washer-Flat
14	3253-6	1	Washer-Lock
15	324-2	1	Screw-HH
16	106-2262	1	Cylinder-HYD
17	321-8	2	Screw-HH
18	106-6774	1	Joint-Ball
19	32151-104	1	Ring-Retaining, External
20	32136-14	1	Nut-SHH
21	3272-12	2	Pin-Cotter
22	106-6898	1	Joint-Ball
22:1	106-6896	1	Seal

Ref	Part No.	Qty.	Description
22:2	302-5	1	Fitting-Grease
23	3220-11	1	Nut-Jam
24	340-132	1	Fitting-HYD, 90 DEG
24:1	237-78	1	O-Ring
24:2	237-21	1	O-Ring
25	106-7801-03	1	Bracket-Line, Steering
26	106-7807	1	Bracket-Line, Steering
27	106-7839	2	Clamp-Tube
28	340-78	6	Nut-Lock, Bulkhead
29	33114-020	4	Screw-HH
30	3256-22	3	Washer-Flat
31	3296-42	5	Nut-Lock, NI
32	108-6938	1	Tube-HYD
32:1	237-22	1	O-Ring
33	108-6939	1	Tube-HYD
33:1	237-22	1	O-Ring
34	106-7804	1	Tube-HYD
34:1	237-21	1	O-Ring
35	108-6940	1	Tube-HYD
35:1	237-21	1	O-Ring
36	106-7806	1	Tube-HYD
36:1	237-21	1	O-Ring
37	321-4	3	Screw-HH
38	340-70	4	Nut-Lock

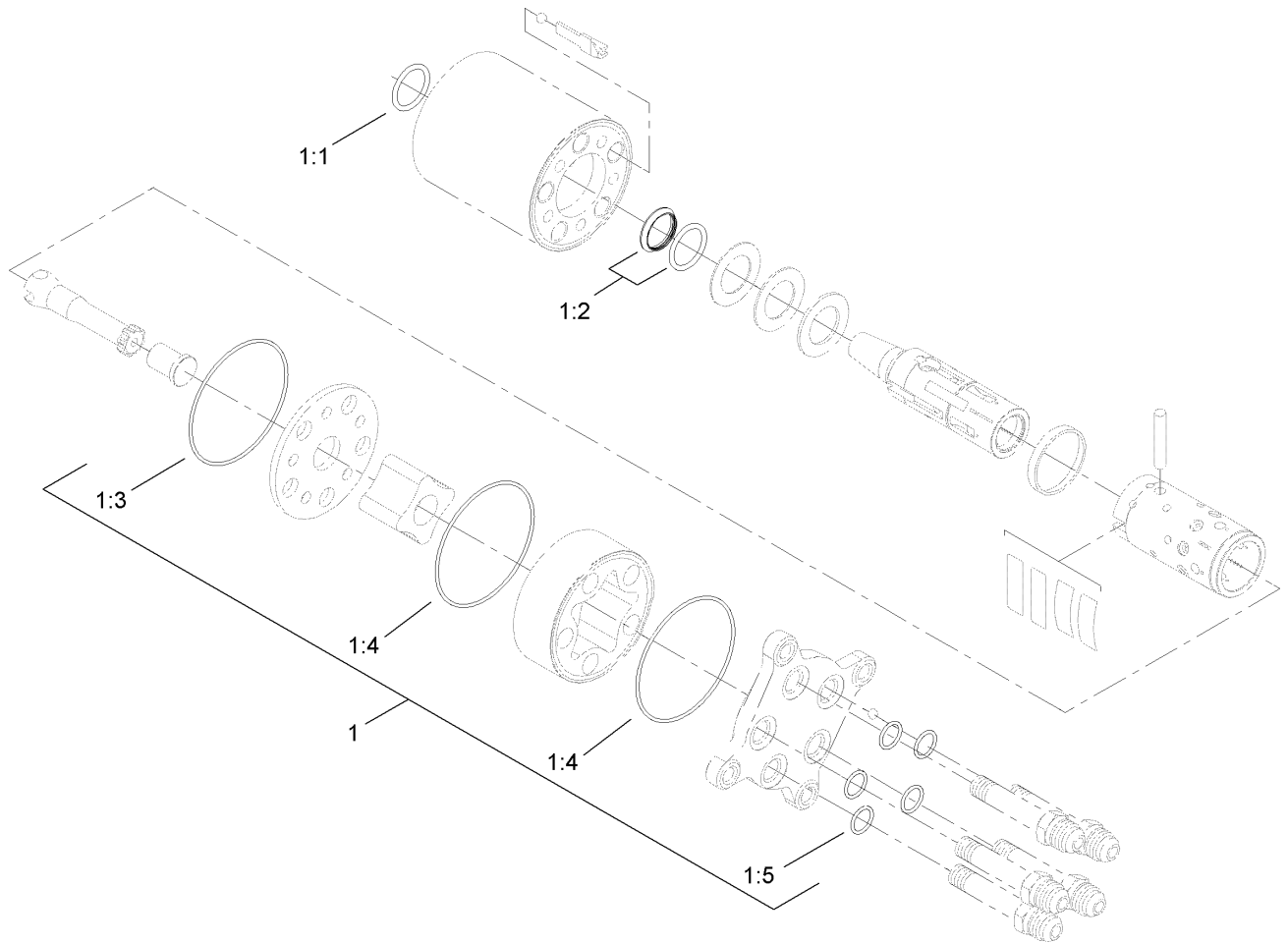

Steering Pump Assembly No. 106-6726

Ref	Part No.	Qty.	Description
1	106-6716	1	Seal Kit
② 1:1		1	Ring-Seal, Dust
② 1:2		1	Seal-Shaft
② 1:3		1	O-Ring
② 1:4		2	O-Ring
② 1:5		5	O-Ring

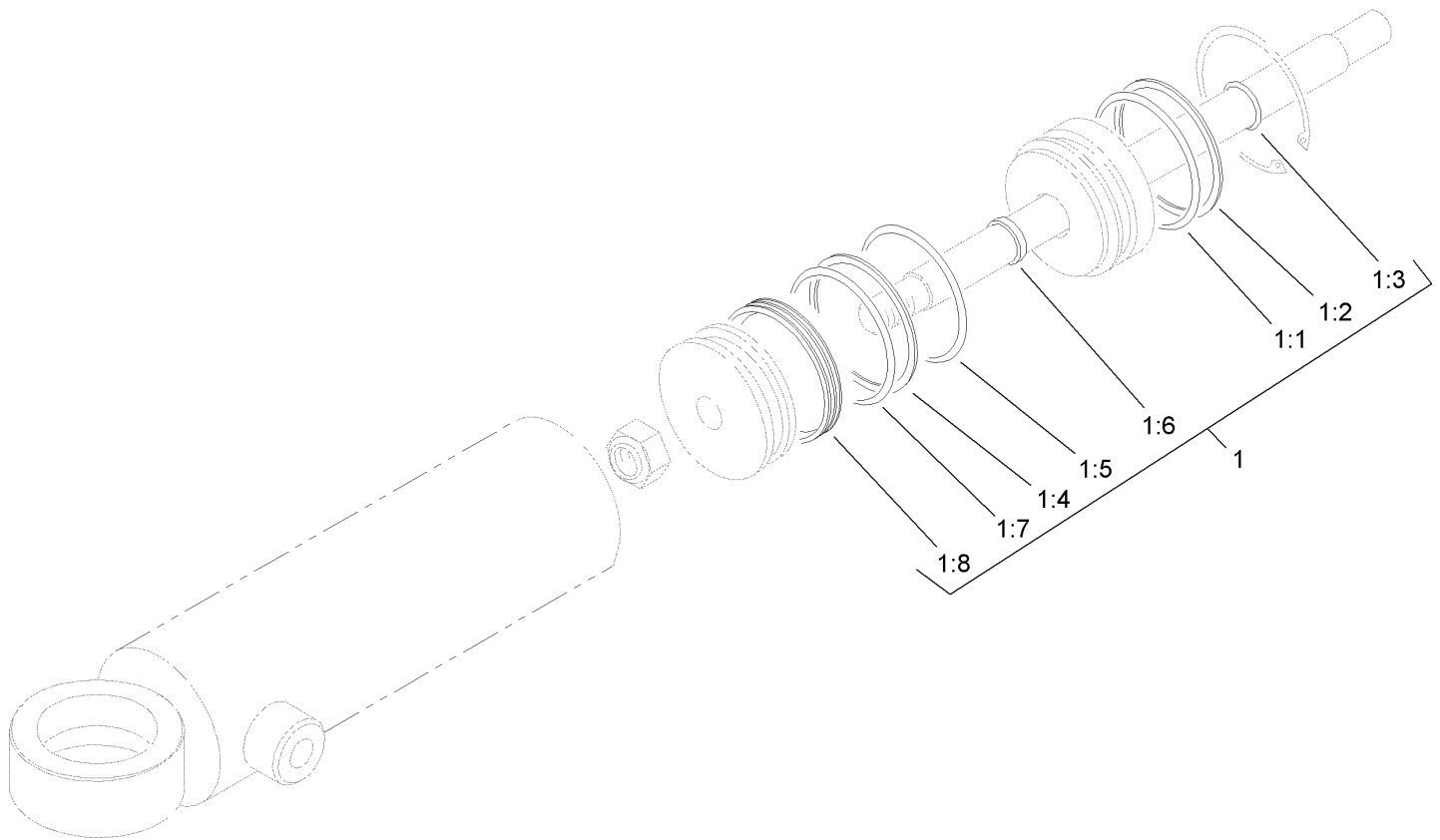

Hydraulic Cylinder Assembly No. 106-2262

Ref	Part No.	Qty.	Description
1	106-6712	1	Seal Kit
1:1		1	O-Ring
1:2		1	O-Ring
1:3		1	Wiper
1:4		1	O-Ring
1:5		1	Back-Up
1:6		1	Seal
1:7		1	Seal
1:8		1	Ring-Wear

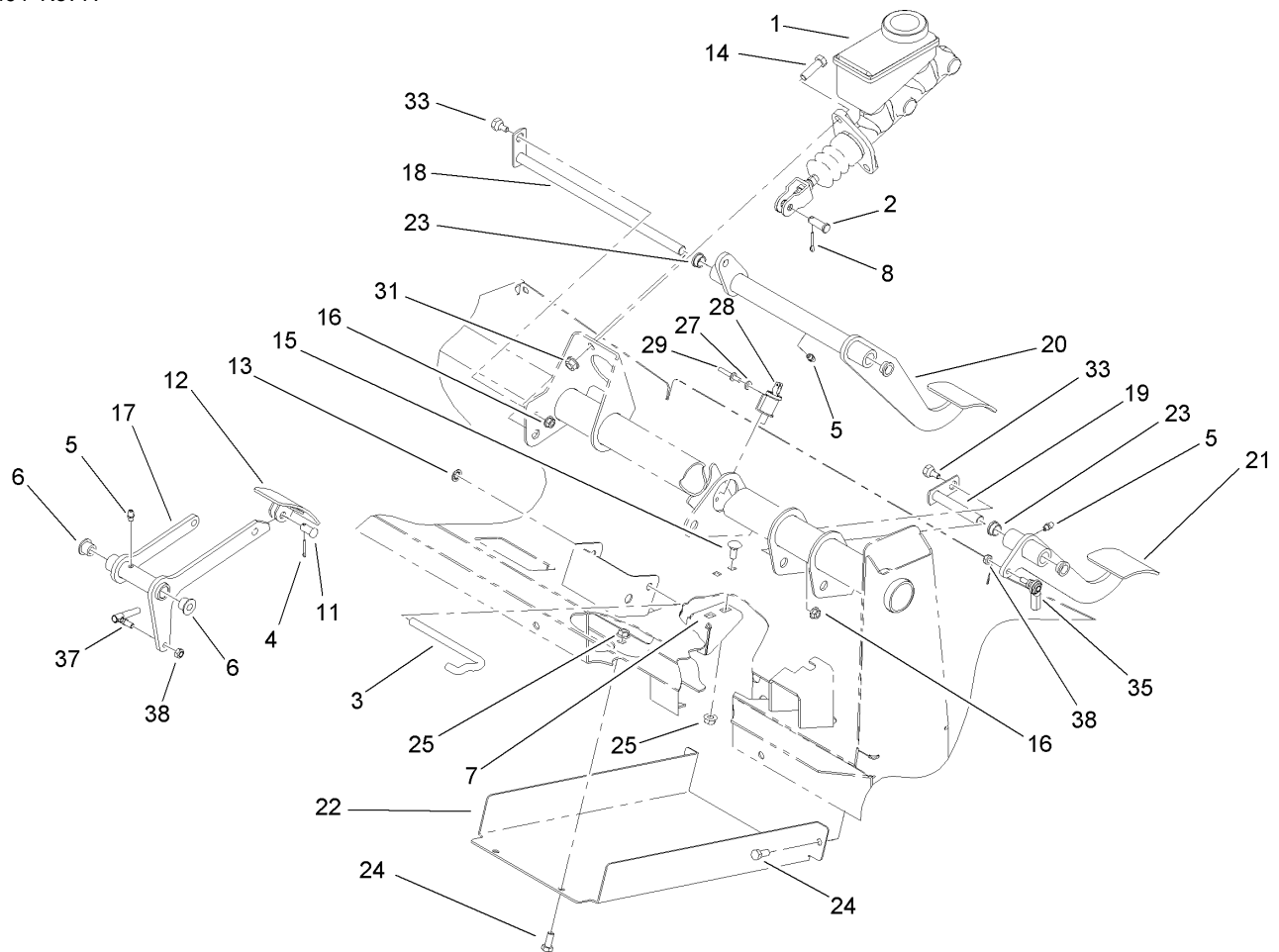

Brake Accelerator and Clutch Assembly

Ref	Part No.	Qty.	Description
1	104-6782	1	Cylinder-Master
2	283-2	1	Pin-Clevis
3	87-2880	1	Shaft-Pedal, Accelerator
4	3272-6	1	Pin-Cotter
5	302-5	3	Fitting-Grease
6	256-259	2	Bushing-Flange
7	106-2421	1	Bracket-Mount, Cable
8	3272-10	1	Pin-Cotter
11	283-85	1	Pin-Clevis
12	93-8969-03	1	Pedal
13	32151-56	1	Ring-Retaining, External
14	323-7	2	Screw-HH
15	3230-1	2	Bolt-CARR
16	32128-33	2	Nut-HF
17	106-2471-03	1	Arm-Pedal, Accelerator
18	106-2475	1	Brake Shaft ASM
19	106-2476	1	Clutch Shaft ASM
20	106-2461-03	1	Brake Pedal ASM
21	106-2457-03	1	Clutch Pedal ASM
22	106-2427-03	1	Cover
23	256-156	4	Bushing-Flange
24	322-3	4	Screw-HH
25	32128-20	6	Nut-HF
27	3256-21	2	Washer-Flat

Ref	Part No.	Qty.	Description
28	95-1653	1	Switch-Pole, Single
29	3290-382	2	Rivet-Pop
31	3290-357	2	Nut-HHF, Whiz
33	63-3410	2	Screw-Shoulder
35	110-2554	1	Rod End-Spherical
37	18-1720	1	Governor Ball Joint ASM
38	3296-13	2	Nut-Lock NI



Master Cylinder Assembly No. 104-6782

Ref	Part No.	Qty.	Description
1	104-6845	1	Reservoir ASM
1:1	92-4112	1	Cap ASM
2	93-8971	2	Seal-Port, Flange
3	92-4103	1	Pin-Stop
4	92-4102	1	Secondary Piston ASM
5	92-4110	1	Clevis
6	21-0360	1	Nut-Hex
7	94-5209	1	Cover-Dust
8	94-5210	1	Rod-Push
9	92-4109	1	Ring-Snap
10	92-4108	1	Retainer-Washer
11	92-4101	1	Primary Piston ASM

--	--	--	--

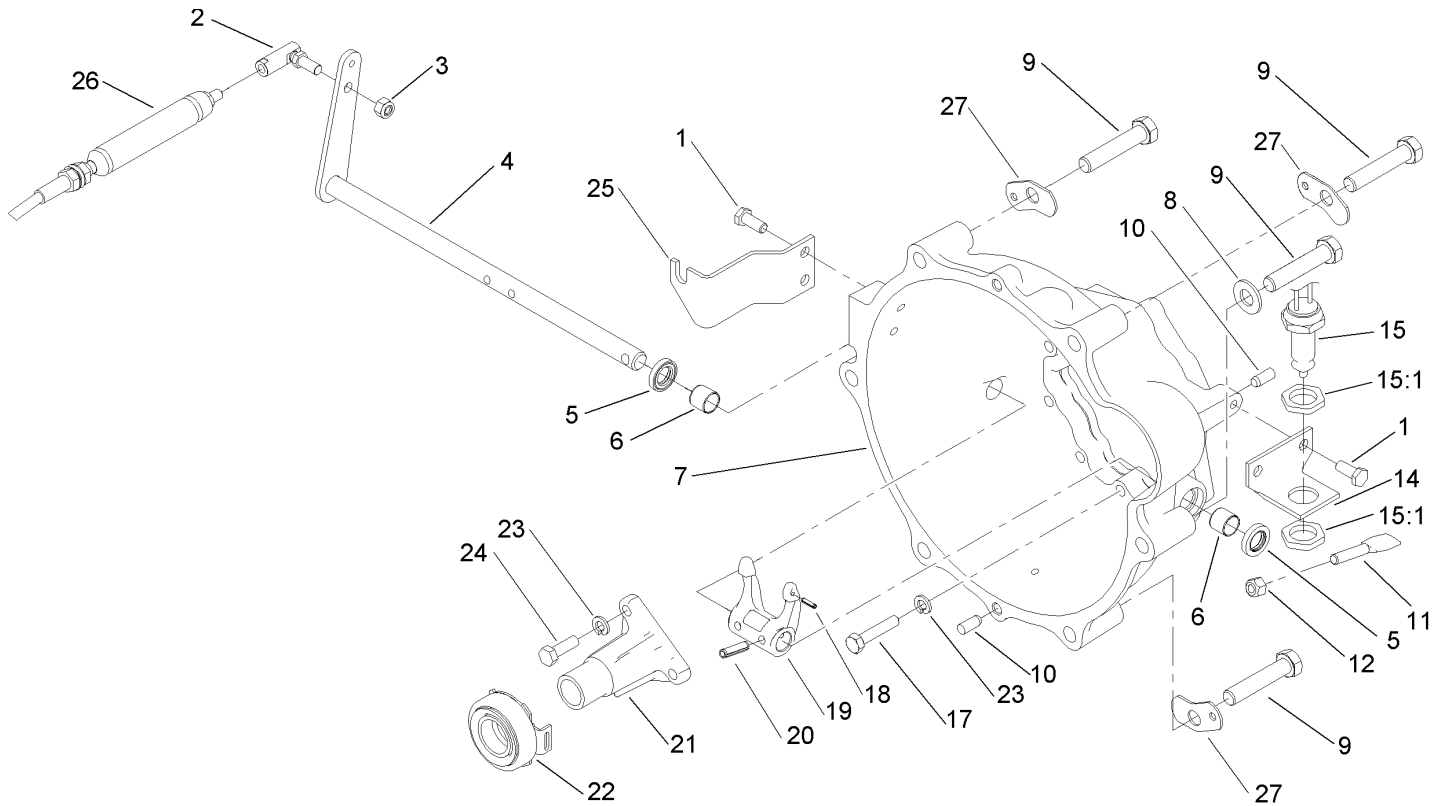

Clutch Linkage Assembly

Ref	Part No.	Qty.	Description
1	33114-020	4	Screw-HH
2	2411-33	1	Balljoint-RH (W/Grommet)
3	3296-4	1	Nut-Lock
4	105-1702	1	Release Shaft ASM
5	87-1920	2	Seal-Oil
6	87-3770	2	Bushing-Housing, Bell
7	104-9249	1	Housing-Bell
8	3256-26	3	Washer-Flat
9	107-7983	6	Screw-HH
10	87-1910	4	Pin-Dowel
11	87-5360	1	Paddle-Clutch, Switch
12	3296-29	1	Nut-Lock, NI
14	87-5350	1	Bracket-Clutch, Switch
15	87-5490	1	Switch-Clutch
15:1	3218-20	2	Nut-Jam
17	33114-040	9	Screw-HH
18	32121-7	1	Pin-Roll, Slotted
19	87-5300	1	Fork-Clutch
20	32121-24	2	Pin-Spring
21	87-5320	1	Release-Guide
22	110-2538	1	Bearing-Release, Clutch
23	3253-4	12	Washer-Lock
24	33114-025	3	Screw-HH
25	112-3116	1	Bracket-Cable, Clutch

Ref	Part No.	Qty.	Description
26	110-2548	1	Cable-Clutch
27	87-6410	3	Bracket-Harness

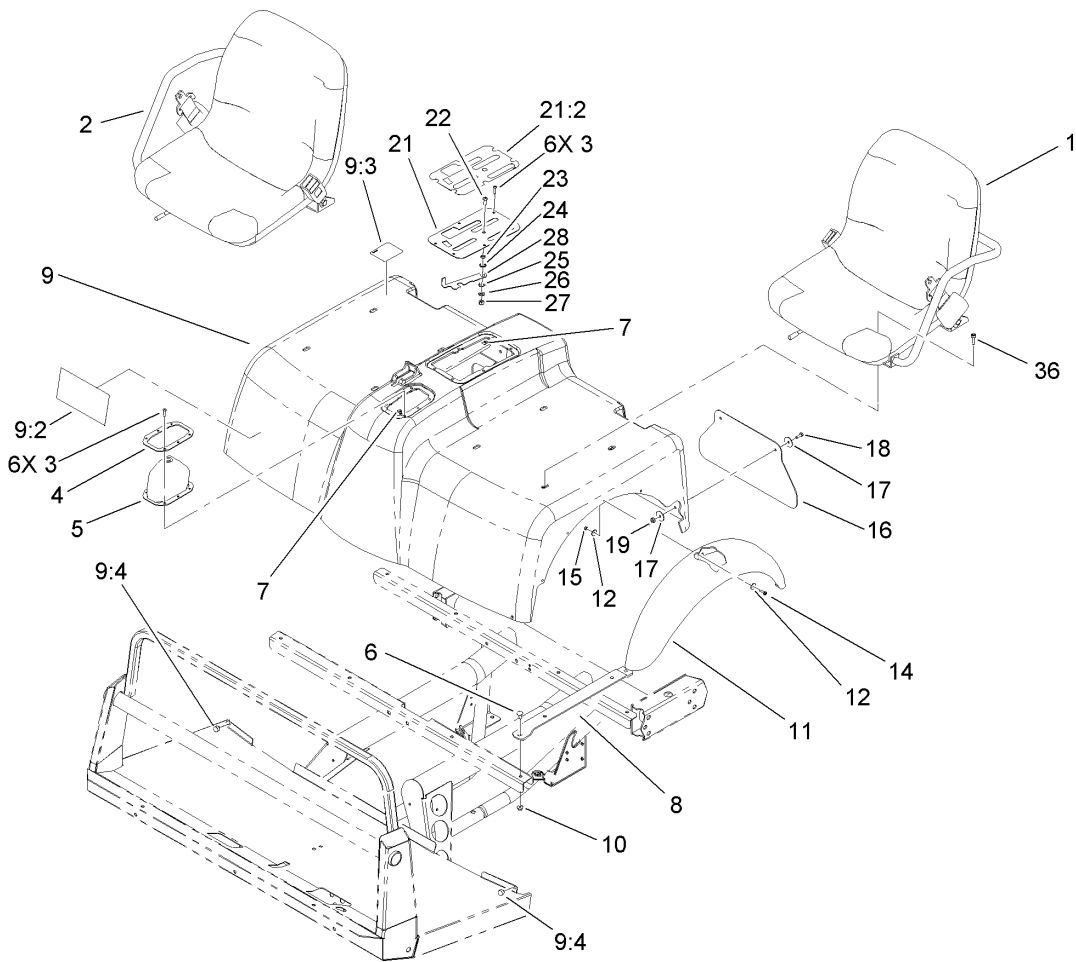

Shroud and Seat Assembly

Ref	Part No.	Qty.	Description
②1		1	LH Seat ASM
②2		1	RH Seat ASM
3	32144-36	12	Screw-PPH
4	87-3760-03	1	Plate-Boot, Shift
5	87-8620	1	Shift Boot ASM
6	3230-1	8	Bolt-CARR
7	106-2388	12	Clip-Fastener
8	107-7957-03	4	Seat Bracket ASM
9	106-2362	1	Seatbase ASM
9:2	106-2384	1	Decal-Reference, Quick
9:3	93-9448	1	Decal-Fuel
9:4	107-8042	2	Bumper-Rubber
10	104-8300	8	Nut-Flange, NI
11	106-2375	2	Fender-Front
12	3256-61	20	Washer-Flat
14	32105-13	10	Screw-SHH
15	3296-2	10	Nut-Lock
16	106-2378	2	Mudflap
17	3256-55	8	Washer-Flat
18	321-4	4	Screw-HH
19	3296-16	4	Nut-Lock, NI
21	106-7886	1	Control Plate ASM
21:2	106-2377	1	Decal-Console
22	3274-55	1	Screw-HSBH

Ref	Part No.	Qty.	Description
23	82-4240	1	Spacer-Bearing
24	94-8196	1	Washer-Nylon
25	3290-221	1	Washer-Spring
26	3256-23	1	Washer-Flat
27	3296-29	1	Nut-Lock, NI
28	106-7984	1	Lever-Detent
36	3274-22	8	Screw-HSH

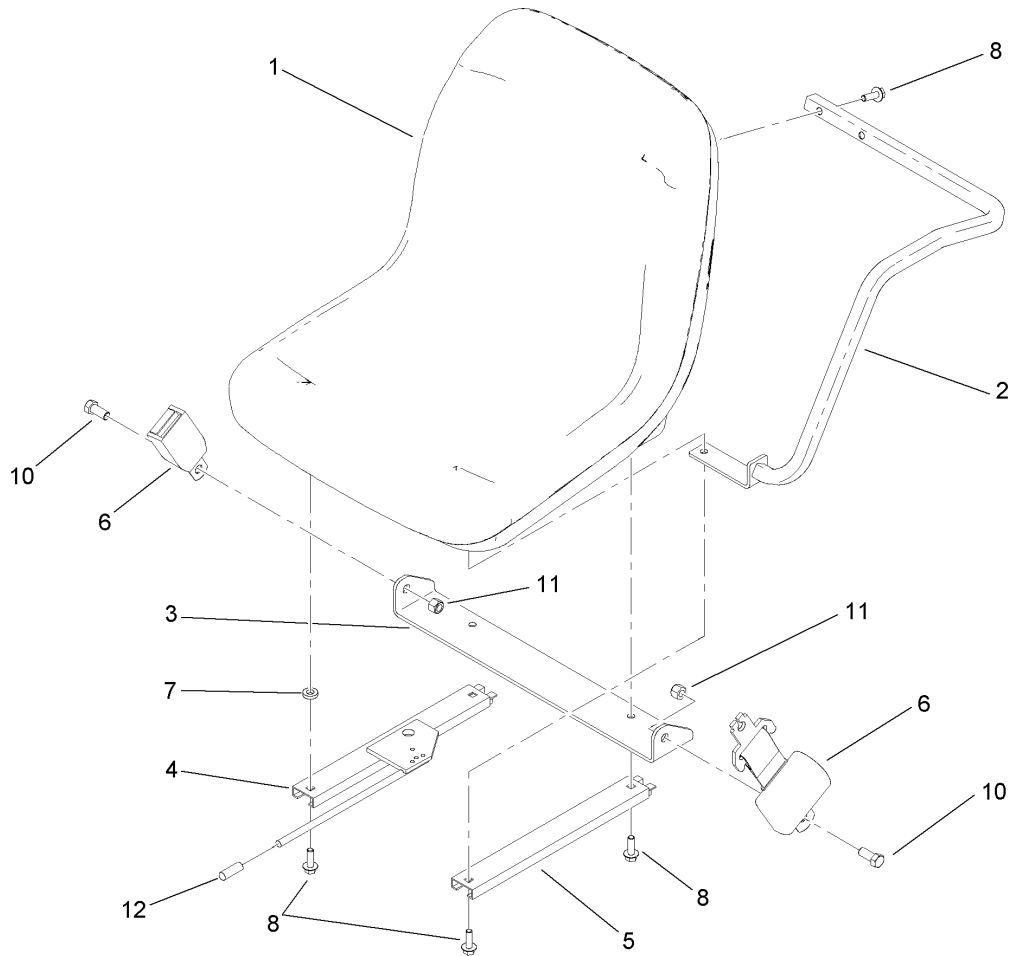

LH Seat Assembly

Ref	Part No.	Qty.	Description
1	112-2923	1	Seat ASM
2	106-7842	1	LH Armrest ASM
3	106-7845	1	Bracket-Belt, Seat
4	106-7847	1	Adjuster-Seat, W/Handle
5	107-7959	1	Adjuster-Slave, 7 Inch
6	106-7848	1	Seat Belt ASM
7	80-7730	1	Spacer
8	3234-29	6	Screw-HHF
10	3212-4	2	Screw-HH
11	3296-7	2	Nut-Lock
12	106-7953	1	Grip-Gray

--	--	--	--

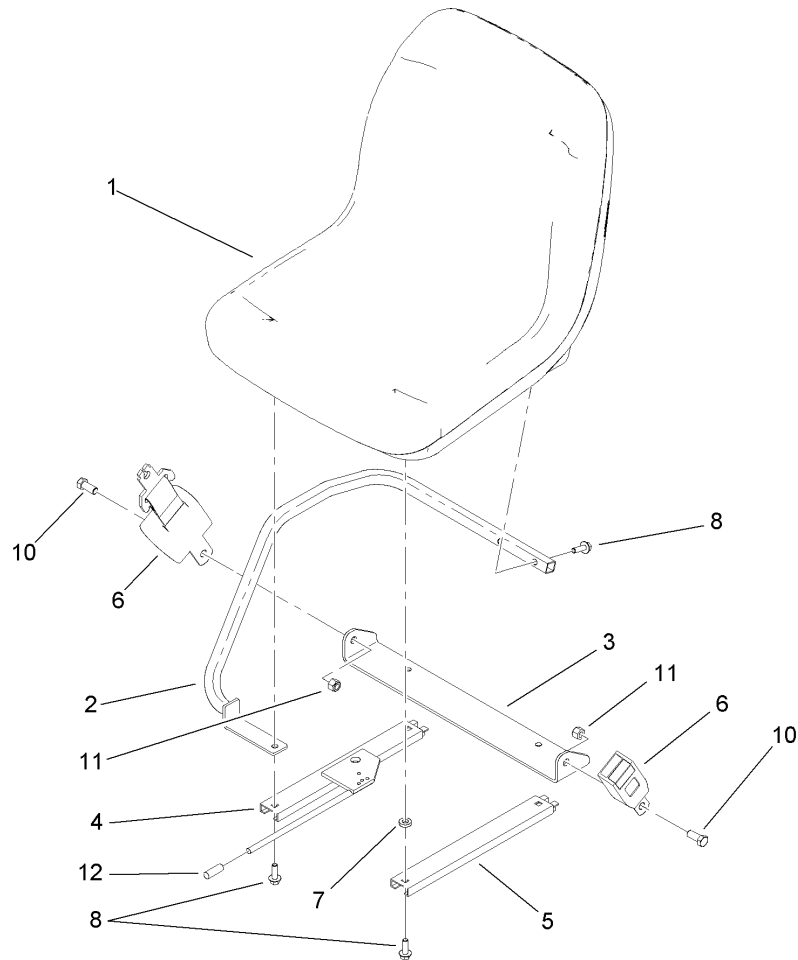

RH Seat Assembly

Ref	Part No.	Qty.	Description
1	112-2923	1	Seat ASM
2	106-7844	1	RH Armrest ASM
3	106-7845	1	Bracket-Belt, Seat
4	106-7847	1	Adjuster-Seat, W/Handle
5	107-7959	1	Adjuster-Slave, 7 Inch
6	106-7848	1	Seat Belt ASM
7	80-7730	1	Spacer
8	3234-29	6	Screw-HHF
10	3212-4	2	Screw-HH
11	3296-7	2	Nut-Lock
12	106-7953	2	Grip-Gray

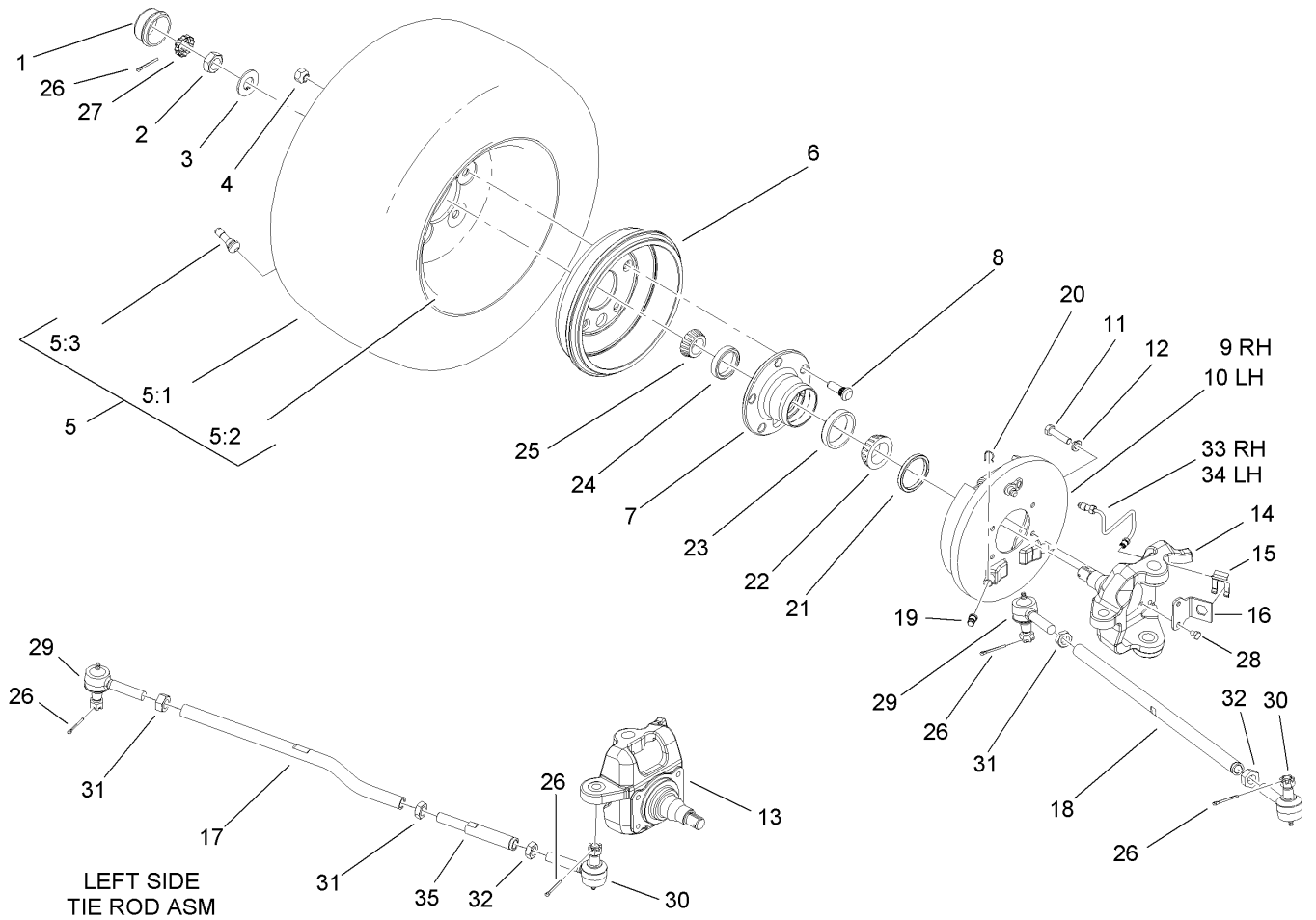

LEFT SIDE
TIE ROD ASM

Front Wheel Assembly

Ref	Part No.	Qty.	Description
1	241-119	2	Cap-Dust
2	3220-7	2	Nut-Jam
3	93-0309	2	Washer-Tab
4	23-7270	10	Nut-Wheel
5		2	Tire And Wheel Assembly
5:1	112-3163	1	Tire
5:2	87-5720	1	Front Rim ASM
5:3	232-27	1	Stem-Valve
6	93-7128	2	Drum-Brake
7	87-5560	2	Hub-Front
8	87-8730	10	Stud
9	87-9170	1	RH Front Brake ASM
10	87-9180	1	LH Front Brake ASM
11	3235-22	8	Screw-HH, Lock
12	3253-21	8	Washer-Lock
13	108-6942	1	Spindle-LH
14	106-6746	1	Spindle-RH
15	87-3580	2	Clip-Retainer
16	106-6747	2	Bracket-Spindle
17	108-6936	1	Rod-Tie, LH
18	106-2327	1	Rod-Tie, RH
19	87-3450	2	Plug-Plate, Brake (Front)
20	87-3310	2	Clip-Cable, Brake
21	108-7019	2	Seal-Shaft

Ref	Part No.	Qty.	Description
22	254-106	2	Cone-Bearing, Tapered
23	254-107	2	Cup-Bearing, Tapered
24	254-72	2	Bearing-Cup, Tapered
25	254-94	2	Bearing-Cone, Tapered
26	3272-12	6	Pin-Cotter
27	93-0307	2	Nut-Lock, Retainer
28	321-1	4	Screw-HH
29	110-2537	2	Ball Joint-RH
30	110-2536	2	Ball Joint-LH
31	3220-11	3	Nut-Jam
32	3218-21	2	Nut-Jam
33	106-7970	1	RH Brake Tube ASM
34	106-7971	1	LH Brake Tube ASM
35	108-6937	1	Turnbuckle-Tie Rod, LH

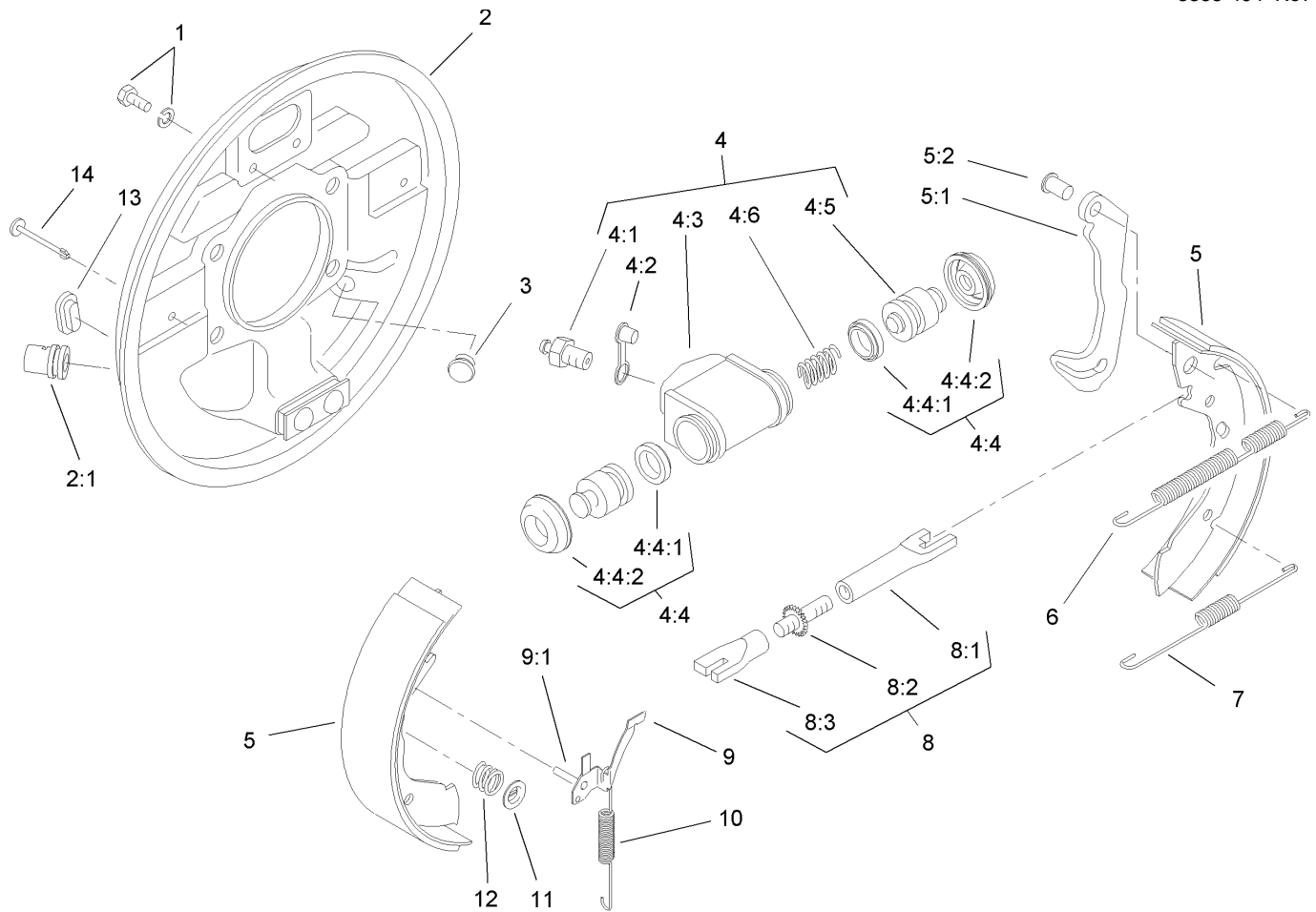

RH Front Brake Assembly No. 87-9170

Ref	Part No.	Qty.	Description
1	92-4135	2	Bolt-Set
2	92-4100	1	RH Backplate ASM
2:1		1	Guide-Pipe
3	92-4146	1	Plunger ASM
4	92-4118	1	Wheel Cylinder ASM
4:1	92-4113	1	Screw-Bleed
4:2	92-4114	1	Cap-Screw, Bleed
4:3		1	Body
4:4	92-4119	1	Seal Kit
4:4:1		2	Seal-L Type
4:4:2		2	Cover-Dust
4:5		2	Piston
4:6		1	Spring
5	92-4143	1	Lined Shoe Kit
5:1		1	Lever-Operating
5:2		1	Pin
6	92-4148	1	Spring-Return, Shoe (Upper, RH)
7	92-4149	1	Spring-Return, Shoe (Lower)
8	92-4145	1	RH Adjustor ASM
8:1		1	Pushrod-Female
8:2		1	Bolt-Adjuster
8:3		1	Sleeve-Adjuster
9	92-4124	1	RH Pawl Lever ASM
9:1		1	Pin-Pawl

Ref	Part No.	Qty.	Description
10	92-4151	1	Spring-Adjuster, RH
11	92-4131	2	Washer-Hold Down, Shoe
12	92-4152	2	Spring-Hold Down, Shoe
13	92-4134	2	Plug-Inspection
14	92-4133	2	Pin-Hold Down, Shoe

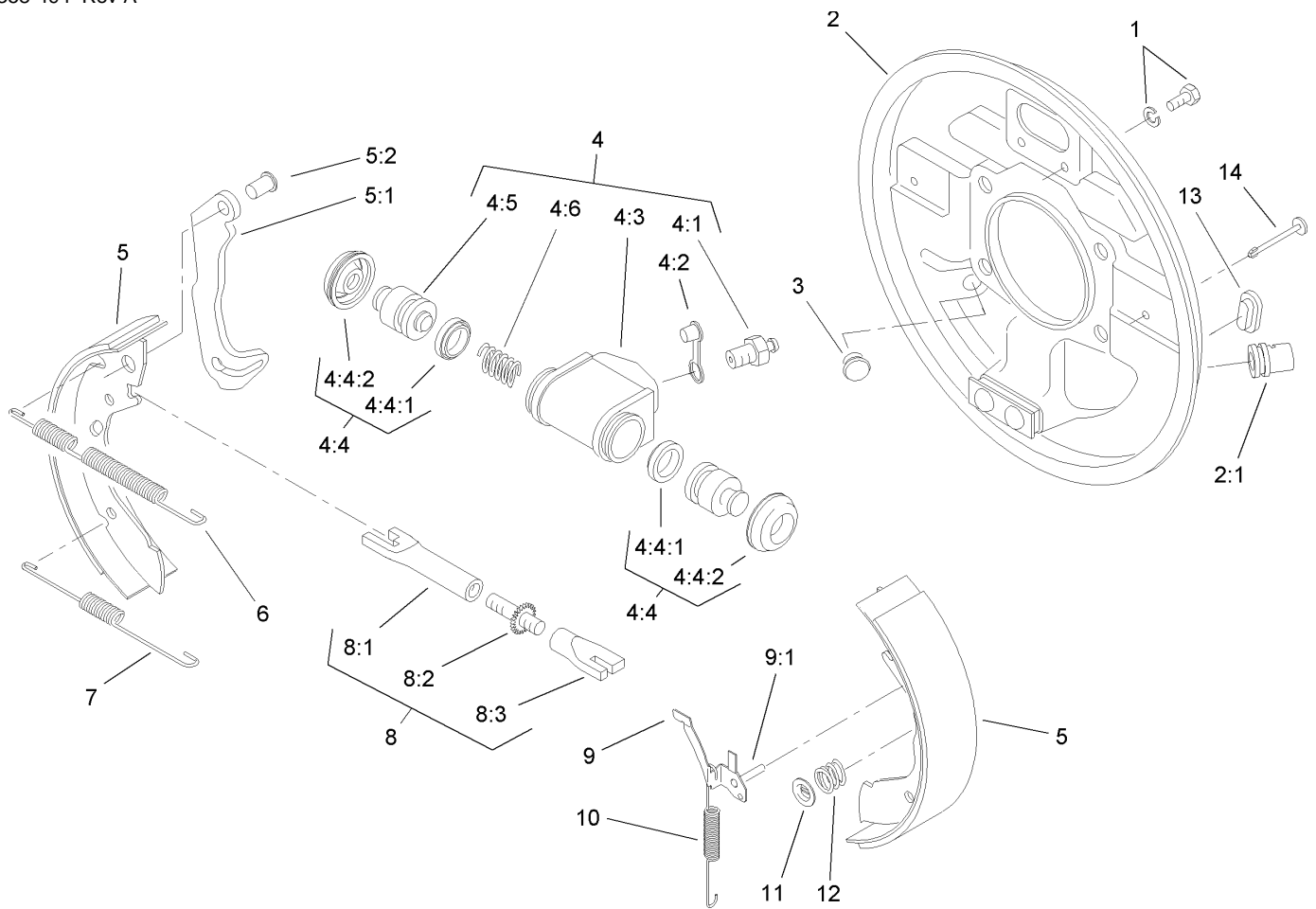

LH Front Brake Assembly No. 87-9180

Ref	Part No.	Qty.	Description
1	92-4135	2	Bolt-Set
2	92-4136	1	LH Backplate ASM
2:1		1	Guide-Pipe
3	92-4146	1	Plunger ASM
4	92-4117	1	Wheel Cylinder ASM
4:1	92-4113	1	Screw-Bleed
4:2	92-4114	1	Cap-Screw, Bleed
4:3		1	Body
4:4	92-4119	1	Seal Kit
4:4:1		2	Seal-L Type
4:4:2		2	Cover-Dust
4:5		2	Piston
4:6		1	Spring
5	92-4143	1	Lined Shoe Kit
5:1		1	Lever-Operating
5:2		1	Pin
6	92-4147	1	Spring-Return, Shoe (Upper, LH)
7	92-4149	1	Spring-Return, Shoe (Lower)
8	92-4144	1	LH Adjuster ASM
8:1		1	Pushrod-Female
8:2		1	Bolt-Adjuster
8:3		1	Sleeve-Adjuster
9	92-4123	1	LH Pawl Lever ASM
9:1		1	Pin-Pawl

Ref	Part No.	Qty.	Description
10	92-4150	1	Spring-Adjuster, LH
11	92-4131	2	Washer-Hold Down, Shoe
12	92-4152	2	Spring-Hold Down, Shoe
13	92-4134	2	Plug-Inspection
14	92-4133	2	Pin-Hold Down, Shoe

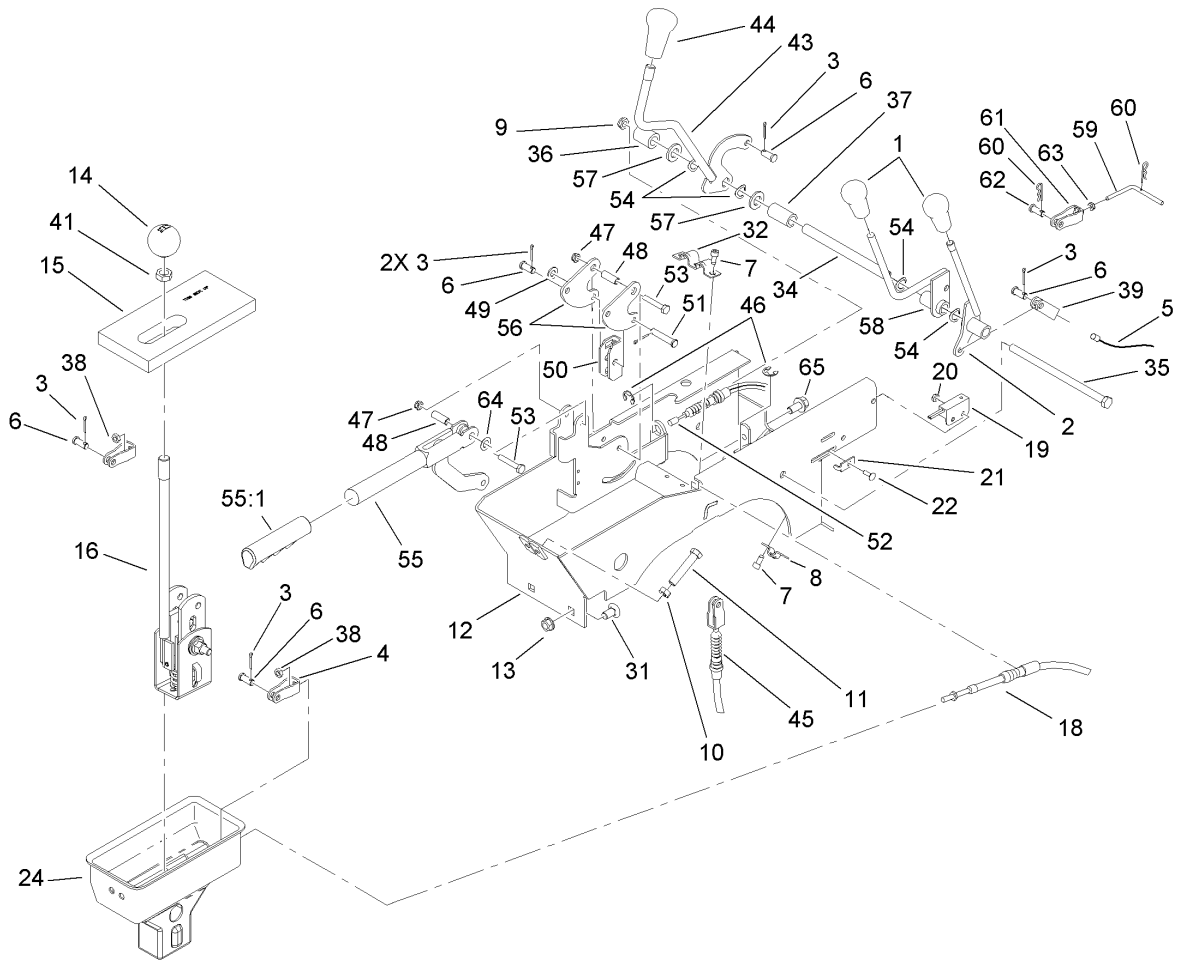

Console Assembly

Ref	Part No.	Qty.	Description
1	106-7903	2	Knob-Control
2	106-7828	1	Lever ASM
3	3272-6	6	Pin-Cotter
4	87-2310	2	Clevis-Cable
5	106-6698	1	Cable-Hi-Low
6	283-62	5	Pin-Clevis
7	65-5220	5	Screw-HSH, Thread Forming
8	87-4340	1	Clamp-Cable
9	3296-59	1	Nut-Lock, NI
10	3217-7	2	Nut-Hex
11	323-10	2	Screw-HH
12	108-6914-03	1	Lever Support ASM
13	3290-357	2	Nut-HHF, Whiz
14	87-6720	1	Knob-Shift
15	87-6570	1	Seal-Boot, Lower
16	106-7887	1	Shift ASM
18	87-4260	2	Cable-Selector, Gear
19	100-1270	1	Switch-Proximity
20	3296-12	1	Nut-Lock
21	100-4872	1	Plate-Switch, Neutral
22	3229-34	1	Bolt-CARR
24	106-2376	1	Boot-Shift, Lower
31	3231-21	2	Screw-CARR
32	87-4960	1	Clamp-Cable

Ref	Part No.	Qty.	Description
34	106-7833	1	Spacer
35	323-36	1	Screw-HH
36	66-6501	1	Spacer-Wheel
37	106-7835	1	Spacer
38	3220-1	2	Nut-Jam
39	87-7160	1	Cable Clevis ASM
41	3218-18	1	Nut-Jam
43	87-5030	1	Lever-Lock, Differential
44	106-7952	1	Knob
45	87-4460	1	Cable-Lock, Differential
46	32120-47	3	Ring-Retaining, External
47	3296-56	2	Nut-Lock, NI
48	114402	2	Spacer
49	3256-23	1	Washer-Flat
50	87-3480	1	Bracket-Equalizer, Cable
51	94-3829	1	Pin-Clevis
52	106-6691	2	Cable-Brake, Park
53	321-9	2	Screw-HH
54	3290-221	4	Washer-Spring
55	104-6842	1	Lever-Brake, Park
55:1	106-7972	1	Grip-Handle
56	106-7814	2	Bellcrank
57	33096-00	2	Washer-Flat
58	106-7960	1	HYD Lever ASM

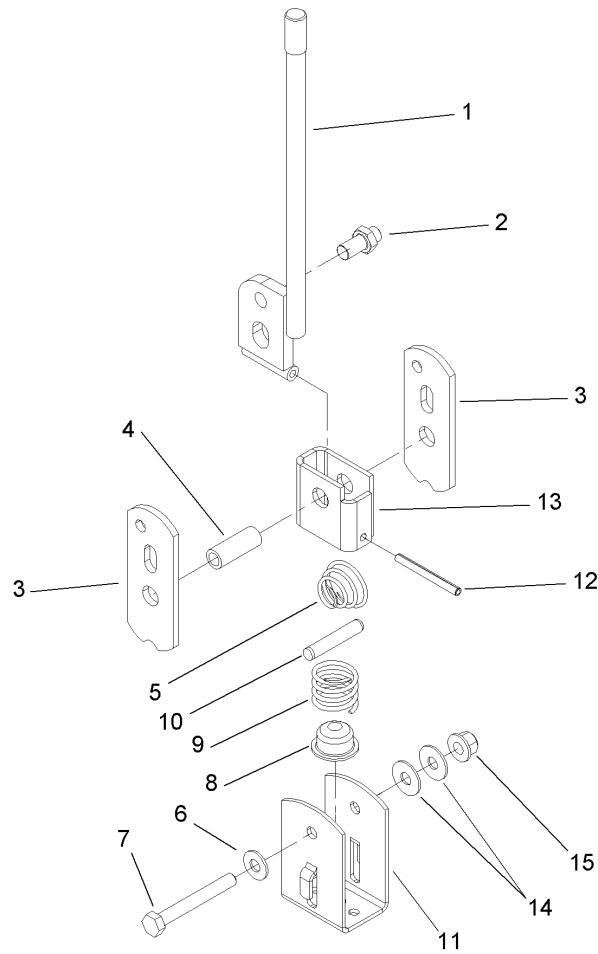

Shift Assembly No. 106-7887

Ref	Part No.	Qty.	Description
1	87-2040	1	Shift Lever ASM
2	87-3650	1	Pin-Shift
3	87-3540	2	Link-Shift
4	87-2520	1	Tube-Pivot
5	87-2900	1	Spring-Compression
6	87-8640	1	Washer-Flat
7	322-12	1	Screw-HH
8	87-3530	1	Button-Shifter
9	87-3660	1	Spring-Compression
10	3290-507	1	Pin-Dowel
11	87-3520	1	Clevis
12	32121-48	1	Pin-Spring
13	87-6040	1	Bracket-Shifter
14	3290-456	2	Washer-Belleville
15	3296-58	1	Nut-Lock, NI

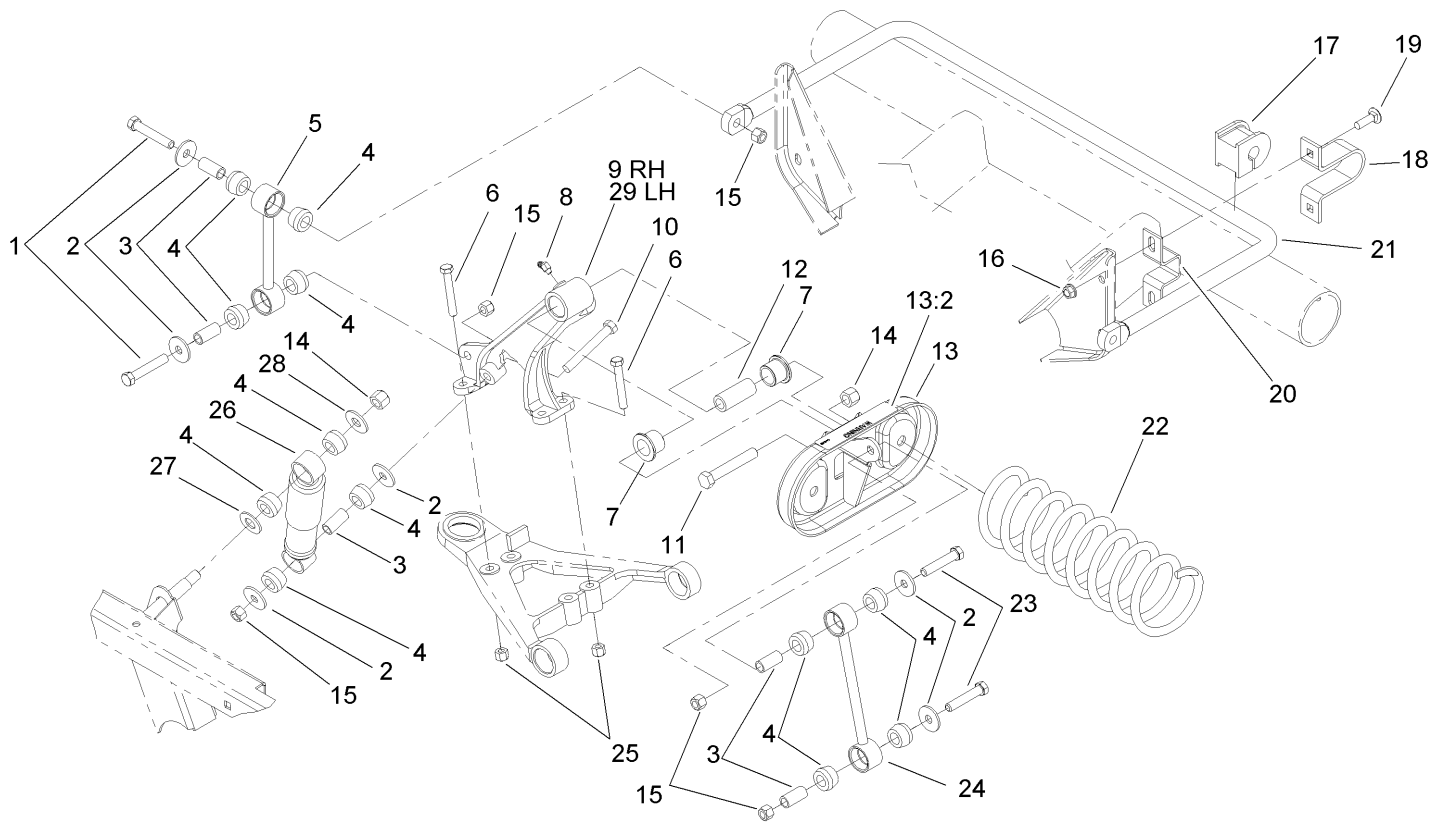

Front Suspension Assembly

Ref	Part No.	Qty.	Description
1	324-10	4	Screw-HH
2	87-5330	12	Washer
3	87-3600	10	Spacer-Absorber, Shock
4	87-3920	24	Bushing
5	87-3860-03	2	Anti-Sway Bar Link ASM
6	323-12	8	Screw-HH
7	33-3090	4	Bushing
8	302-11	2	Fitting-Lube, 45 DEG
9	87-0150-03	1	Tower-Control Arm, RH
10	324-13	2	Screw-HH
11	325-13	2	Screw-HH
12	87-2500	2	Sleeve-Spring, Pivot
13	105-7958	2	Spring Cradle ASM
13:2	93-9879	1	Decal-Warning
14	3296-23	4	Nut-Lock, NI
15	3296-48	10	Nut-Lock, NI
16	3290-357	4	Nut-HHF, Whiz
17	87-3910	2	Bushing-Rubber
18	87-4010-03	2	Clamp-Bar, Sway
19	3231-25	4	Screw-CARR
20	87-3890-03	2	Bracket-Bar, Sway
21	87-3850-03	1	Bar-Sway, Anti
22	105-4183-01	2	Spring-Compression
23	324-9	4	Screw-HH

Ref	Part No.	Qty.	Description
24	106-2302-03	2	Stabilizer Link ASM
25	3296-39	8	Nut-Lock, NI
26	87-3110	2	Absorber-Shock
27	3256-27	2	Washer-Flat
28	3256-6	2	Washer-Flat
29	87-0160-03	1	Tower-Control Arm, LH

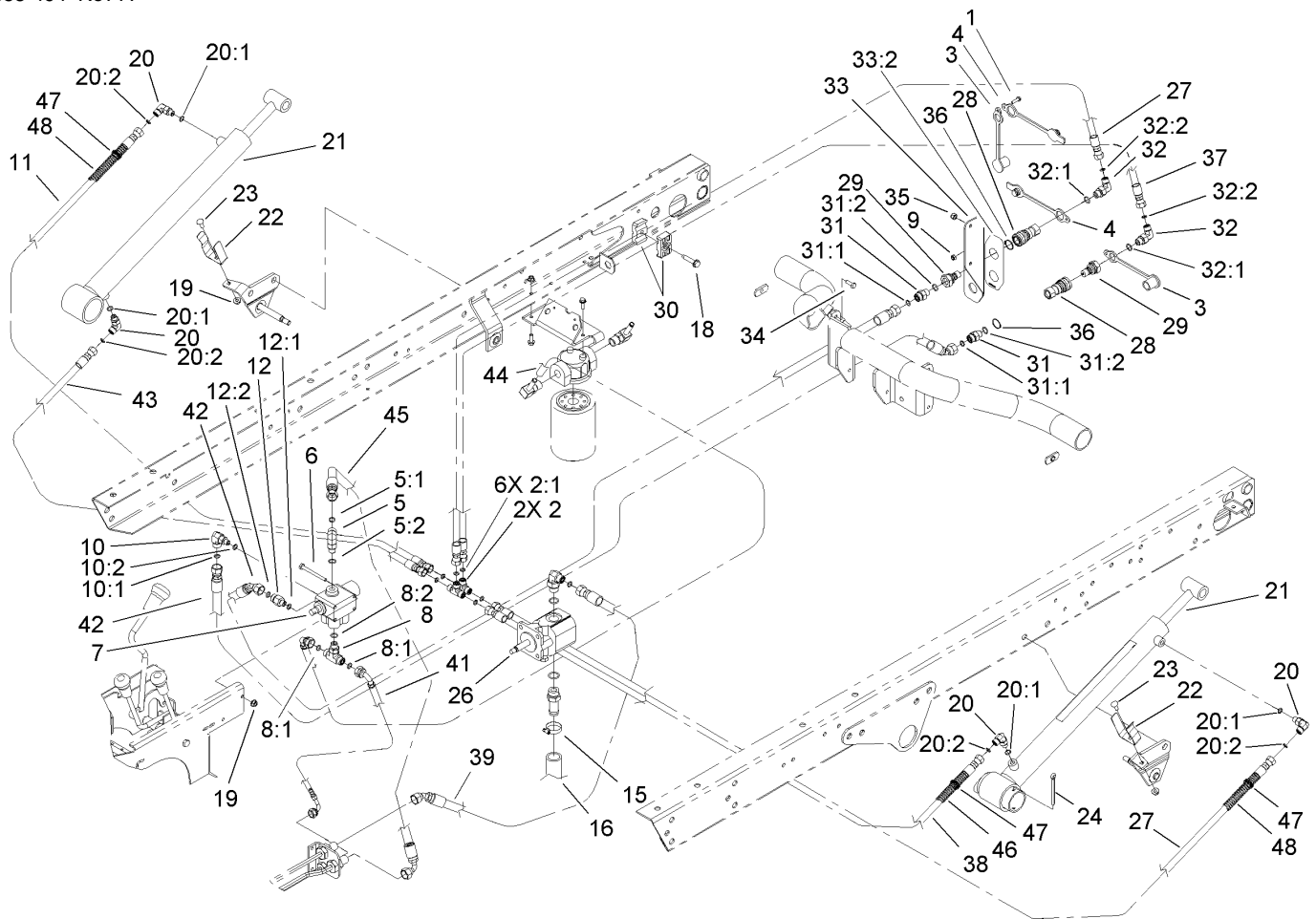

Lift Valve and Hydraulic Assembly

Ref	Part No.	Qty.	Description
1	32105-13	1	Screw-SHH
2	340-21	2	Fitting
2:1	237-21	3	O-Ring
3	106-7881	2	Cap-Dust, HYD
4	106-7882	2	Plug-Dust, HYD
5	340-77	1	Fitting-HYD, 90 DEG
5:1	237-22	1	O-Ring
5:2	237-42	1	O-Ring
6	321-14	2	Screw-HH
7	43-1950	1	Valve-Control, HYD
8	340-94	1	Adapter
8:1	237-22	2	O-Ring
8:2	237-42	1	O-Ring
9	3296-2	1	Nut-Lock
10	340-97	1	Fitting-HYD, 90 DEG
10:1	237-22	1	O-Ring
10:2	237-78	1	O-Ring
11	92-7564	1	Hose ASM
12	340-88	1	Adapter
12:1	237-22	1	O-Ring
12:2	237-78	1	O-Ring
15	2412-34	1	Clamp-Hose
16	87-8030	1	Hose-Suction
18	32144-57	1	Screw

Ref	Part No.	Qty.	Description
19	32128-33	4	Nut-HF
20	340-132	4	Fitting-HYD, 90 DEG
20:1	237-78	1	O-Ring
20:2	237-21	1	O-Ring
21	106-7939	2	HYD Cylinder ASM
22	108-3109	2	Retainer-Cylinder
23	3229-1	2	Screw-CARR
24	3272-37	2	Pin-Cotter
26	106-6649	1	Pump-Gear, HYD
27	104-3716	2	HYD Hose ASM
28	106-7968	2	Coupler-Quick, Female
29	106-7969	2	Coupler-Quick, Male
30	56-7976	2	Clamp-Tube
31	340-2	2	Fitting-HYD, Straight
31:1	237-22	1	O-Ring
31:2	237-42	1	O-Ring
32	340-82	2	Adapter
32:1	237-42	1	O-Ring
32:2	237-21	1	O-Ring
33	106-7923	1	Quick Coupler Bracket ASM
33:2	106-7888	1	Decal-Couplers, Quick
34	3234-21	2	Screw-Cap
35	3296-42	2	Nut-Lock, NI
36	32151-83	2	Ring-Snap

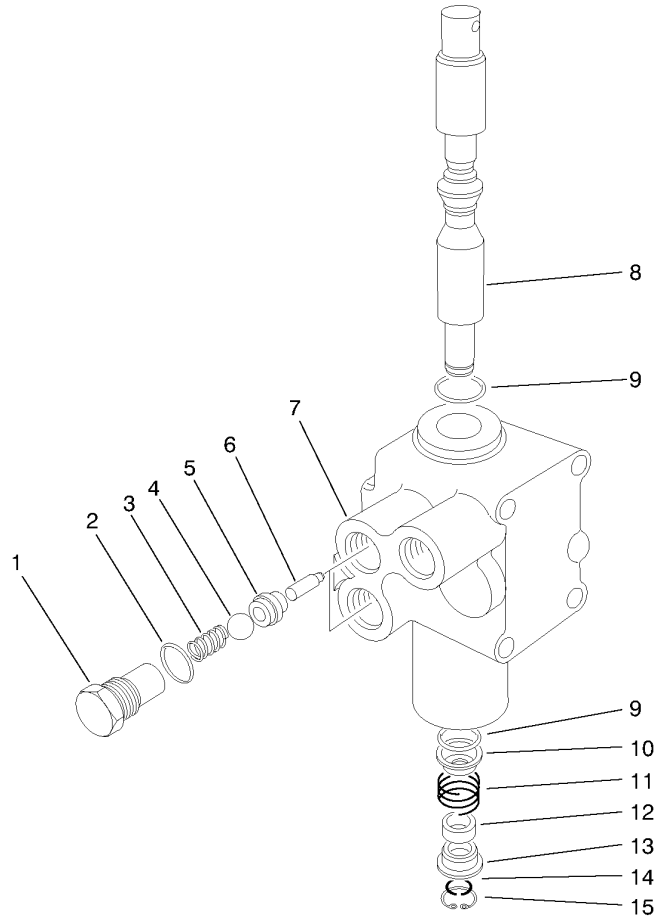

Control Valve Assembly No. 43-1950

Ref	Part No.	Qty.	Description
1	22-8330	2	Plug
2	237-42	2	O-Ring
3	22-8340	2	Spring
4	22-8350	2	Ball
5	22-8370	2	Seat-Valve
6	22-8360	2	Pin
7		1	Body
8	22-8420	1	Spool
9	22-8500	2	O-Ring
10	22-8380	2	Retainer
11	22-8410	1	Spring
12	23-3030	1	Spacer
13	22-8480	1	Ring-Snap
14	22-8490	1	Ring-Snap

--	--	--	--

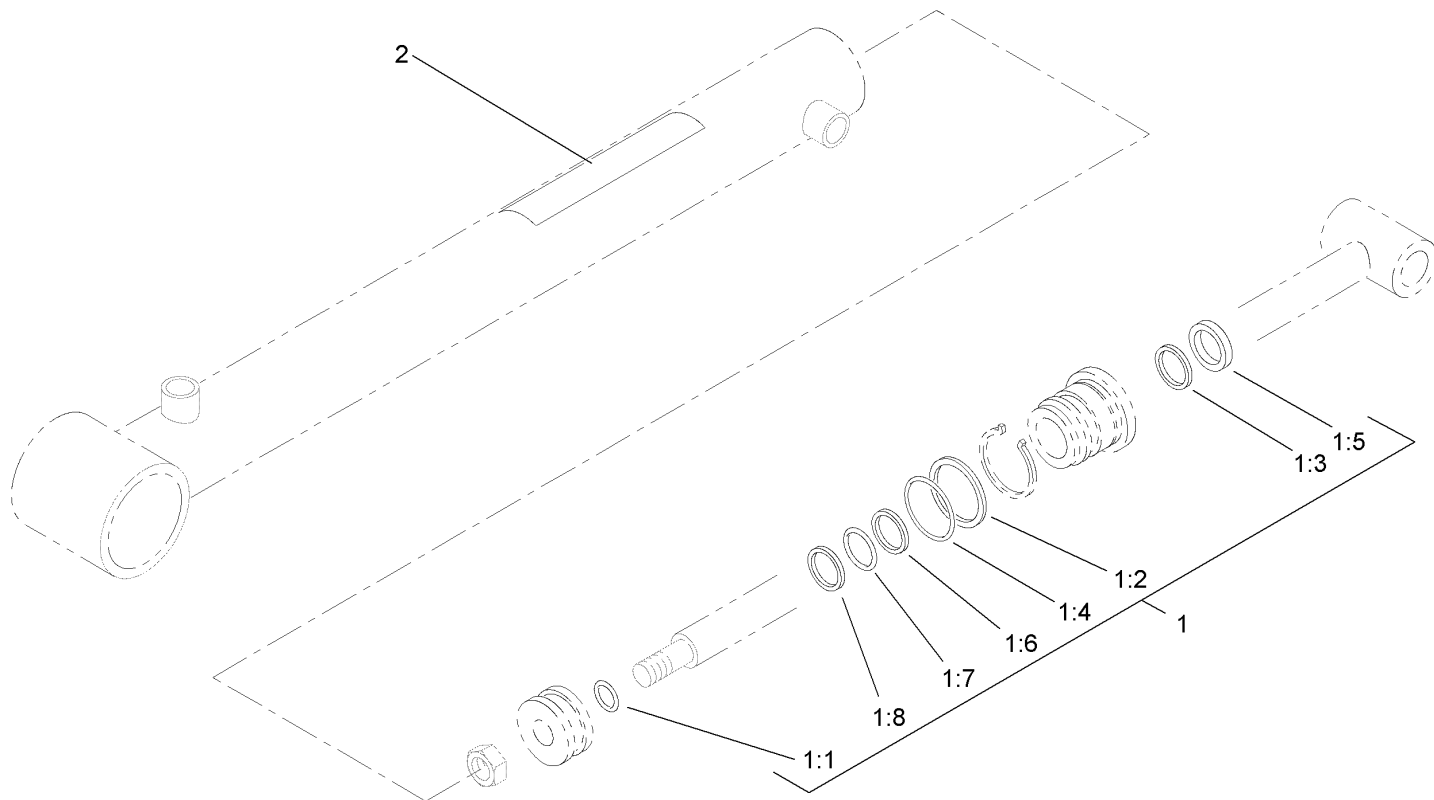

Hydraulic Cylinder Assembly No. 106-7939

Ref	Part No.	Qty.	Description
1	106-7941	1	Seal Kit
1:1		1	O-Ring
1:2		1	O-Ring
1:3		1	Seal
1:4		1	Back-Up
1:5		1	Wiper
1:6		1	Seal
1:7		1	O-Ring
1:8		1	Ring-Wear
2	93-9852	1	Decal-Warning

--	--	--	--

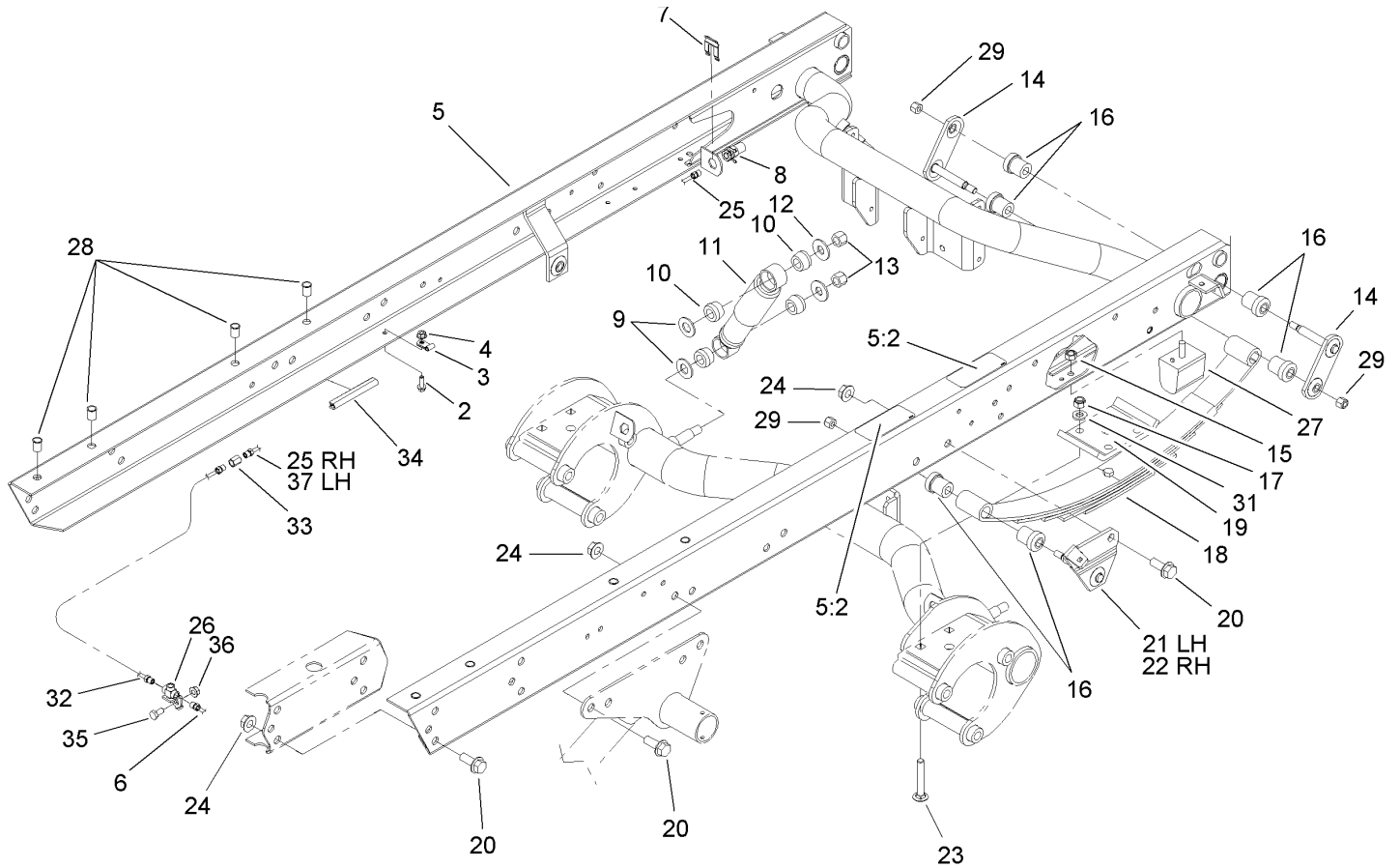

Rear Frame Assembly

Ref	Part No.	Qty.	Description
2	3234-4	4	Screw-HHF
3	2412-149	4	Clamp-Hose
4	32128-33	4	Nut-HF
5	105-7959	1	Frame Channel ASM
5:2	93-8071	2	Decal-Surface, Hot
6	94-3843	1	LH Rear Brake Tube ASM
7	87-3580	2	Clip-Retainer
8	87-4100	2	Hose-Brake, Rear
9	3256-27	4	Washer-Flat
10	87-3920	8	Bushing
11	87-3110	2	Absorber-Shock
12	3256-6	4	Washer-Flat
13	3296-23	4	Nut-Lock, NI
14	87-3980	4	Shackle ASM
15	48-9520	2	Nut
16	87-4760	12	Bushing-Rubber
17	3296-76	8	Nut-Lock, NI
18	87-1490	2	Spring-Leaf, Rear
19	87-7470-03	2	Plate-Spring, Clamp
20	3234-38	24	Screw-HHF
21	87-3960	1	LH Spring Mount ASM
22	87-3940	1	RH Spring Mount ASM
23	3232-17	8	Screw-CARR
24	32128-23	24	Nut-HF

Ref	Part No.	Qty.	Description
25	94-3846	1	RH Rear Brake Tube ASM
26	87-3560	1	Tee
27	87-3470	2	Bumper-Axle, Rear
28	32148-9	8	Insert-Nut
29	3296-39	6	Nut-Lock, NI
31	87-7480	8	Washer
32	94-3845	1	RH Rear Brake Tube ASM
33	87-3570	2	Union
34	43-4300	1	Trim-Frame, Rear
35	322-2	1	Screw-HH
36	32128-20	1	Nut-HF
37	94-3844	1	LH Rear Brake Tube ASM

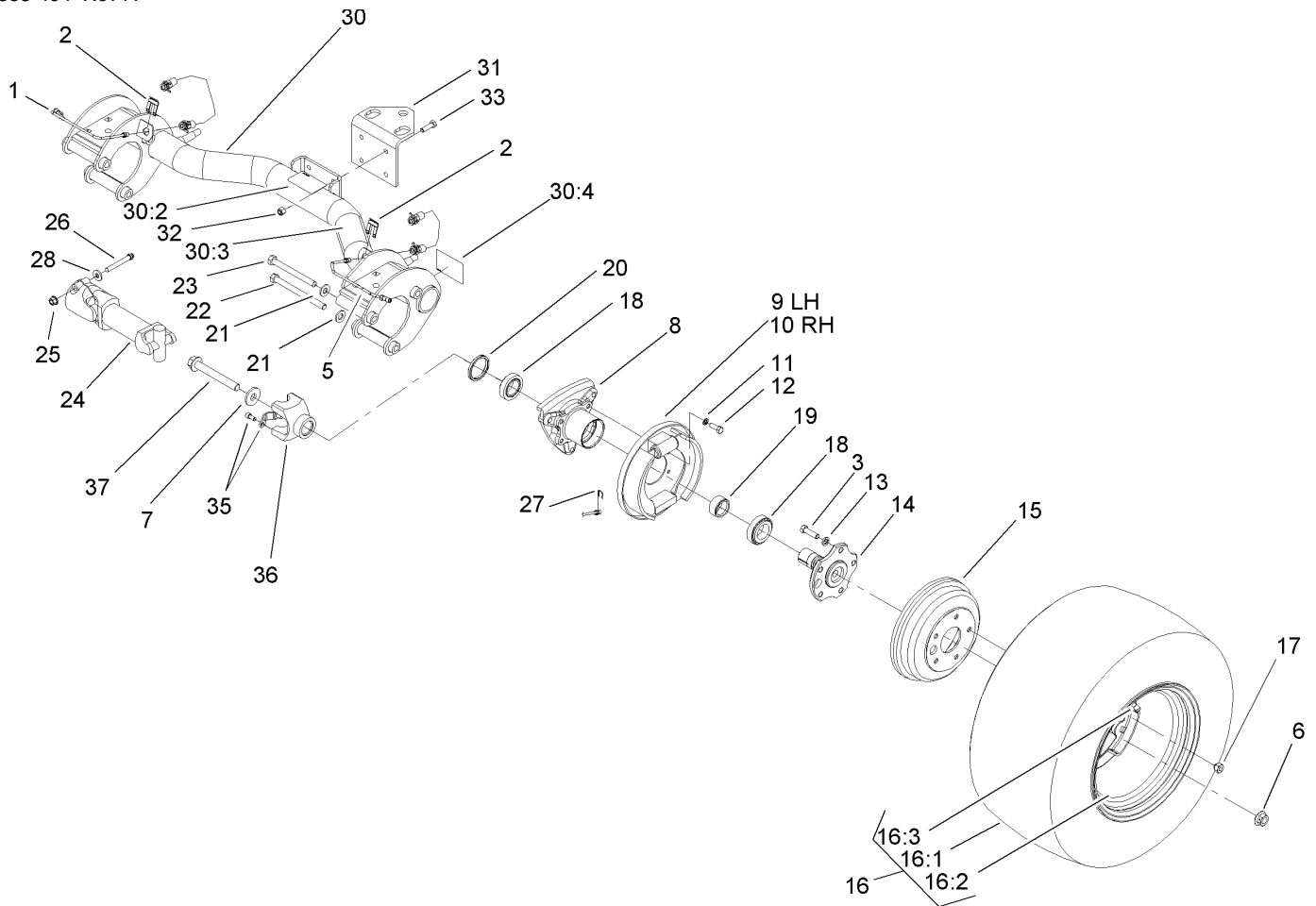

Rear Axle Assembly

Ref	Part No.	Qty.	Description
1	87-4090	1	RH Rear Brake Tube ASM
2	87-3580	2	Clip-Retainer
3	87-2080	10	Bolt-Hex, TAP
5	87-4080	1	LH Rear Brake Tube ASM
6	105-1764	2	Nut-Flange, Side Lock
7	104-9216	2	Washer-Hardened
8	87-2240	2	Housing-Axle
9	93-7126	1	LH Rear Brake ASM
10	93-7125	1	RH Rear Brake ASM
11	3253-21	8	Washer-Lock
12	3235-22	8	Screw-HH, Lock
13	3253-6	10	Washer-Lock
14	105-1717-03	2	Axle-Stub
15	93-7128	2	Drum-Brake
16		2	Tire And Wheel ASM
16:1	106-7868	1	Tire
16:2	87-6750	1	Wheel
16:3	232-27	1	Stem-Valve
17	23-7270	10	Nut-Wheel
18	87-1970	2	Bearing
19	87-4060	2	Spacer-Bearing, Wheel
20	108-7019	2	Seal-Shaft
21	87-7270	6	Washer-Thrust
22	325-20	5	Screw-HH

Ref	Part No.	Qty.	Description
23	325-19	1	Screw-HH
24	98-2918	2	Driveshaft ASM
25	32128-36	4	Nut-HF
26	98-2939	4	Screw-Cap
27	87-3310	2	Clip-Cable, Brake
28	80-6990	4	Washer-Hardened
30	105-7961	1	Rear Axle ASM
30:2	93-9442	1	Decal-Atf
30:3	93-9862	1	Decal-Danger
30:4	93-9449	2	Decal-Driveshaft
31	92-5951-03	1	Angle-Hitch
32	3296-39	4	Nut-Lock, NI
33	323-7	4	Screw-HH
35	92-4189	2	Strap Kit
36	92-4190	2	Yoke
37	105-1763	2	Screw-HHF

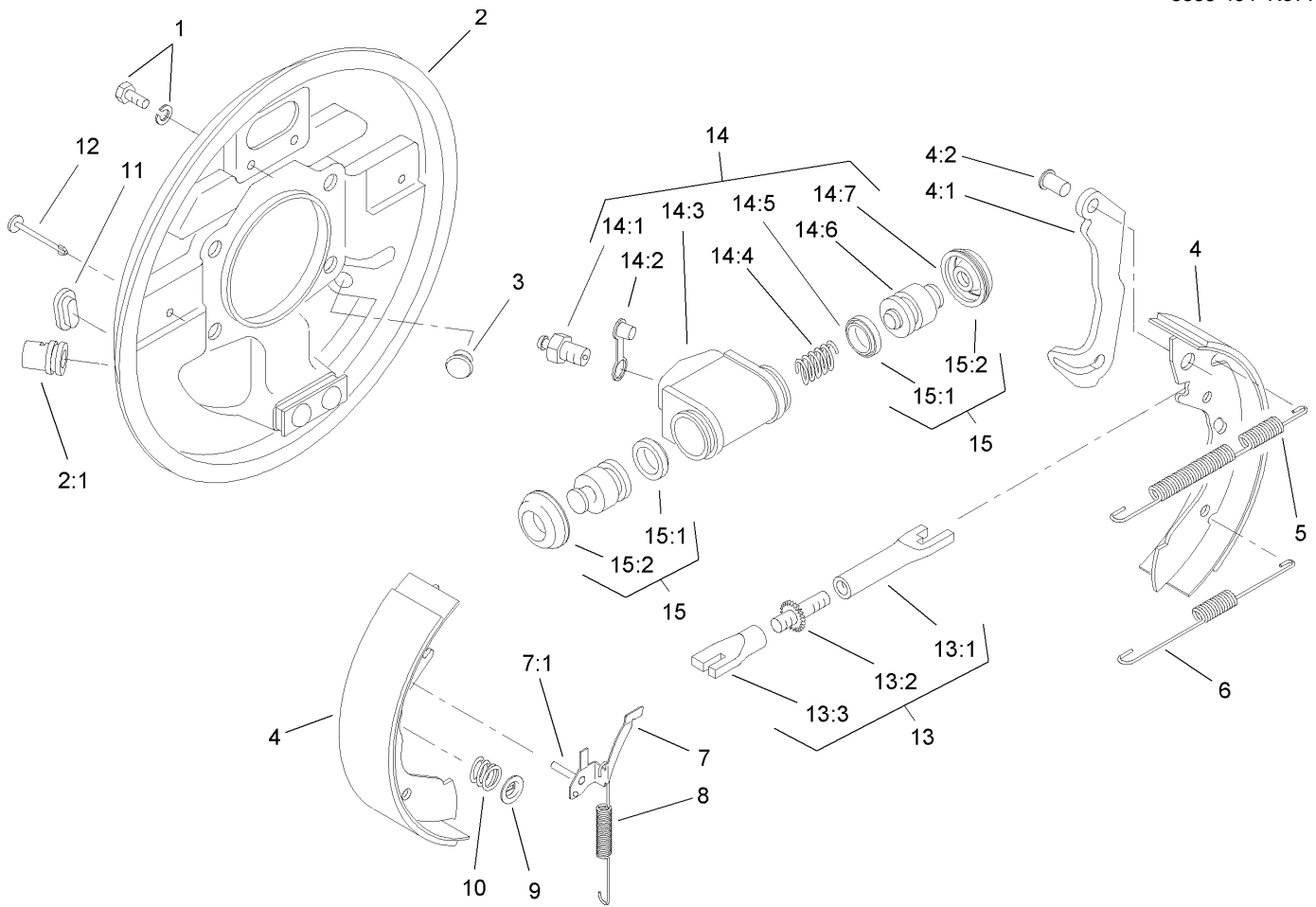

LH Rear Brake Assembly No. 93-7126

Ref	Part No.	Qty.	Description
1	92-4135	2	Bolt-Set
2	92-4136	1	LH Backplate ASM
2:1		1	Guide-Pipe
3	92-4146	1	Plunger ASM
4	92-4143	1	Lined Shoe Kit
4:1		1	Lever-Operating
4:2		1	Pin
5	92-4147	1	Spring-Return, Shoe (Upper, LH)
6	92-4149	1	Spring-Return, Shoe (Lower)
7	92-4123	1	LH Pawl Lever ASM
7:1		1	Pin-Pawl
8	92-4150	1	Spring-Adjuster, LH
9	92-4131	2	Washer-Hold Down, Shoe
10	92-4152	2	Spring-Hold Down, Shoe
11	92-4134	1	Plug-Inspection
12	92-4133	2	Pin-Hold Down, Shoe
13	92-4144	1	LH Adjuster ASM
13:1		1	Pushrod-Female
13:2		1	Bolt-Adjuster
13:3		1	Sleeve-Adjuster
14	92-4140	1	LH Wheel Cylinder ASM
14:1	92-4137	1	Screw-Bleed
14:2	92-4114	1	Cap-Screw, Bleed
14:3		1	Body

Ref	Part No.	Qty.	Description
14:4		1	Spring
14:5		2	Seal-L Type
14:6		2	Piston
14:7		2	Cover-Dust
15	92-4142	1	Seal Kit
15:1		2	Seal-L Type
15:2		2	Cover-Dust

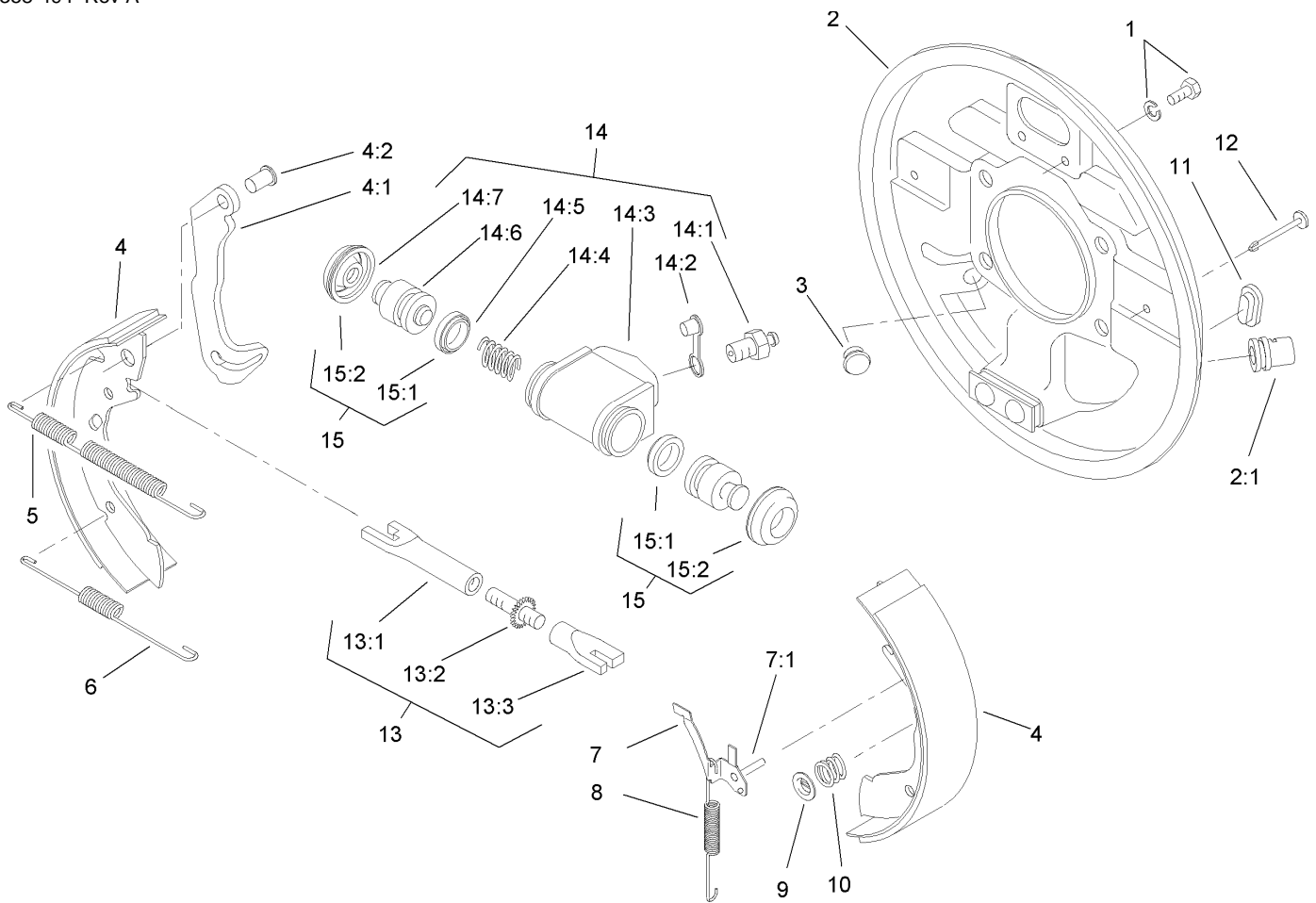

RH Rear Brake Assembly No. 93-7125

Ref	Part No.	Qty.	Description
1	92-4135	2	Bolt-Set
2	92-4100	1	RH Backplate ASM
2:1		1	Guide-Pipe
3	92-4146	1	Plunger ASM
4	92-4143	1	Lined Shoe Kit
4:1		1	Lever-Operating
4:2		1	Pin
5	92-4148	1	Spring-Return, Shoe (Upper, RH)
6	92-4149	1	Spring-Return, Shoe (Lower)
7	92-4124	1	RH Pawl Lever ASM
7:1		1	Pin-Pawl
8	92-4151	1	Spring-Adjuster, RH
9	92-4131	2	Washer-Hold Down, Shoe
10	92-4152	2	Spring-Hold Down, Shoe
11	92-4134	1	Plug-Inspection
12	92-4133	2	Pin-Hold Down, Shoe
13	92-4145	1	RH Adjustor ASM
13:1		1	Pushrod-Female
13:2		1	Bolt-Adjuster
13:3		1	Sleeve-Adjuster
14	92-4141	1	RH Wheel Cylinder ASM
14:1	92-4137	1	Screw-Bleed
14:2	92-4114	1	Cap-Screw, Bleed
14:3		1	Body

Ref	Part No.	Qty.	Description
14:4		1	Spring
14:5		2	Seal-L Type
14:6		2	Piston
14:7		2	Cover-Dust
15	92-4142	1	Seal Kit
15:1		2	Seal-L Type
15:2		2	Cover-Dust

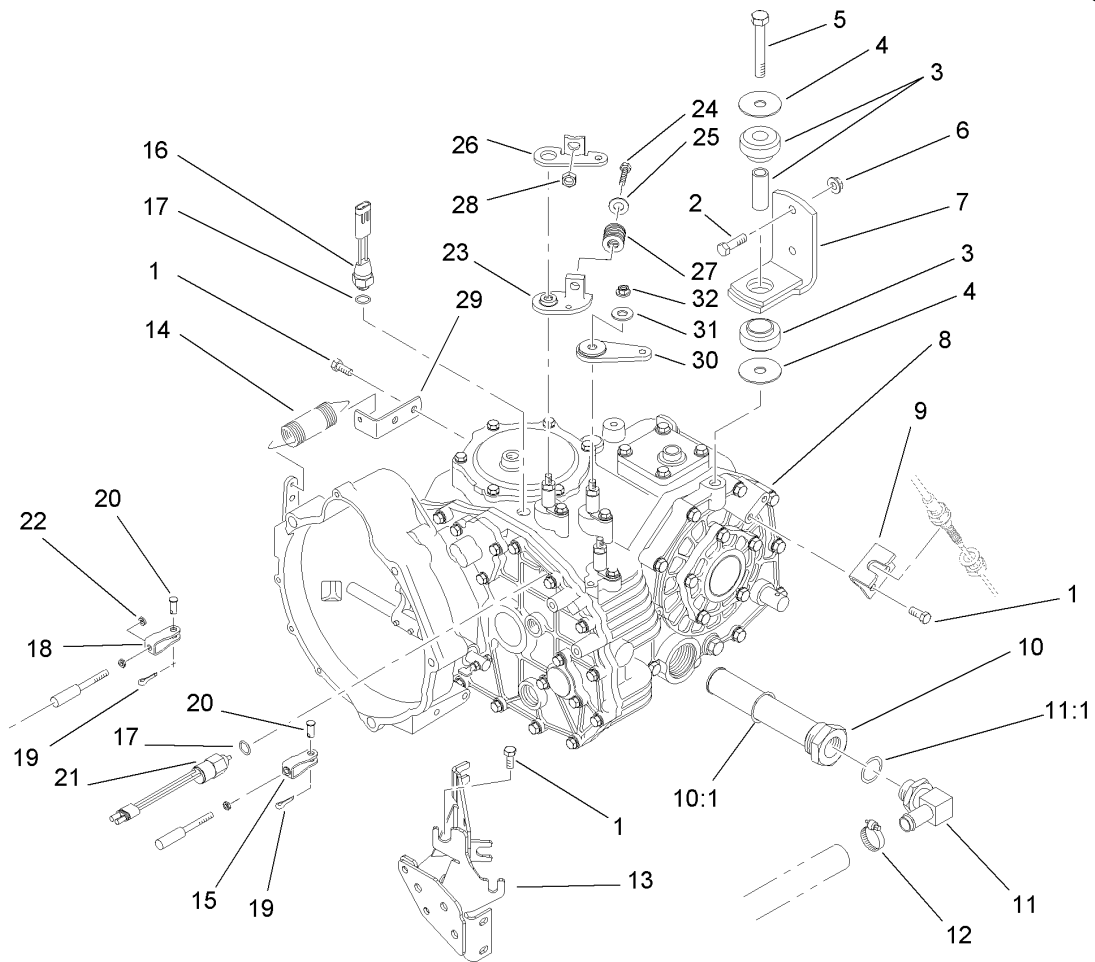

Transaxle Assembly

Ref	Part No.	Qty.	Description
1	33114-020	5	Screw-HH
2	323-7	4	Screw-HH
3	106-7865	2	Engine Mount ASM
4	87-5100	4	Washer-Snubbing
5	33116-080	2	Screw-HH
6	3296-39	4	Nut-Lock, NI
7	87-5800-03	2	Transaxle Mount ASM
8	105-4180	1	2 Wheel Drive Transaxle ASM
9	87-4470	1	Bracket-Lock, Differential
10	87-3990	1	Strainer-Transaxle
10:1	237-123	1	O-Ring
11	353-987	1	Fitting-HYD, 90
11:1	237-81	1	O-Ring
12	2412-34	1	Clamp-Hose
13	105-4207-03	1	Cable Mount ASM
14	68-9950	1	Spring-Traction
15	87-7160	1	Cable Clevis ASM
16	72-4310	1	Switch-Ball
17	237-30	2	O-Ring
18	87-2310	2	Clevis-Cable
19	3272-6	3	Pin-Cotter
20	283-62	3	Pin-Clevis
21	87-6710	1	Switch-Transmission
22	3220-1	2	Nut-Jam

Ref	Part No.	Qty.	Description
23	87-7970	1	Arm-Shift
24	323-10	1	Screw-HH
25	3256-4	1	Washer-Flat
26	87-8250	1	Plate-Arm, Shift
27	87-6910	1	Spring-Compression
28	32128-21	1	Nut-HF
29	87-7170	1	Bracket-Spring, Clutch
30	87-7960	2	Lever-Shift
31	80-6990	3	Washer-Hardened
32	48-9520	3	Nut

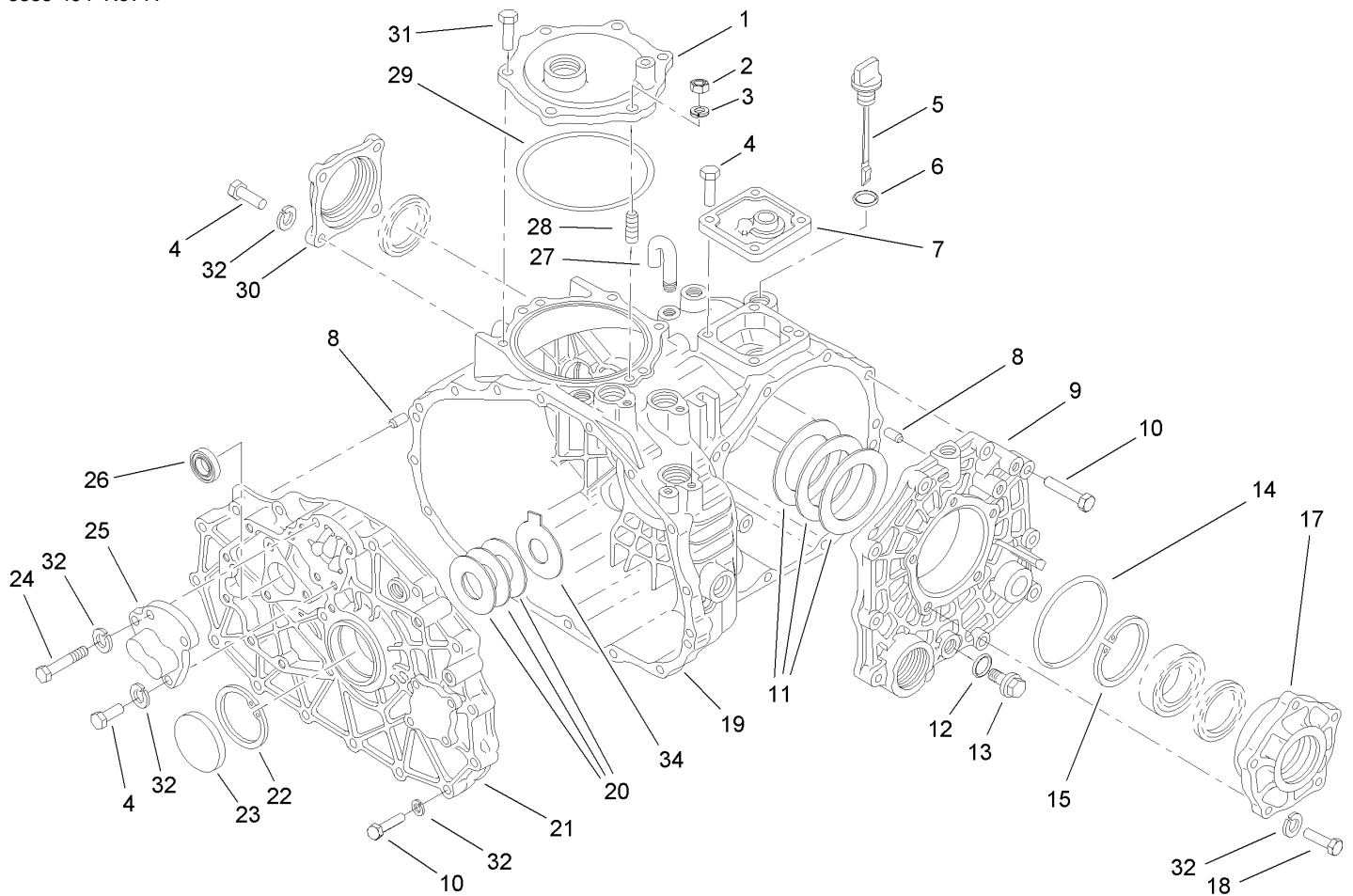

Case Assembly Transaxle Assembly No. 105-4180

Ref	Part No.	Qty.	Description
1	92-0656	1	Cover-Upper, PTO
2	68-9400	1	Nut-Flange
3	92-0762	1	Washer-Spring
4	33114-025	11	Screw-HH
5	92-0662	1	Cap-Oil
6	92-0788	1	O-Ring
7	92-0652	1	Cover-Upper
8	92-0765	4	Pin-Parallel
9	92-0653	1	Cover-Side
10	33114-040	25	Screw-HH
11	92-0809	1	Set-Shim
12	92-0787	1	O-Ring
13	92-0773	1	Plug-Drain
14	92-0789	1	O-Ring
15	92-0760	1	Ring-Snap
17	92-0654	1	Carrier-Differential
18	33114-030	5	Screw-HH
19	92-0651	1	Case-Transmission
20	100-4460	1	Shim Set
21	100-4461	1	Plate-Center
22	92-0759	1	Ring-Snap
23	92-0807	1	Cap-Sealing
24	48-7560	1	Bolt-HH
25	92-0706	1	Shaft-Fork

Ref	Part No.	Qty.	Description
26	92-0791	1	Seal-Oil
27	92-0743	1	Breather-Air
28	92-0804	1	Stud
29	92-0790	1	O-Ring
30	92-0655	1	Cover-Seal, Axle
31	92-0796	5	Bolt
32	3253-4	42	Washer-Lock
34	100-4465	1	Shim (W/Tab)

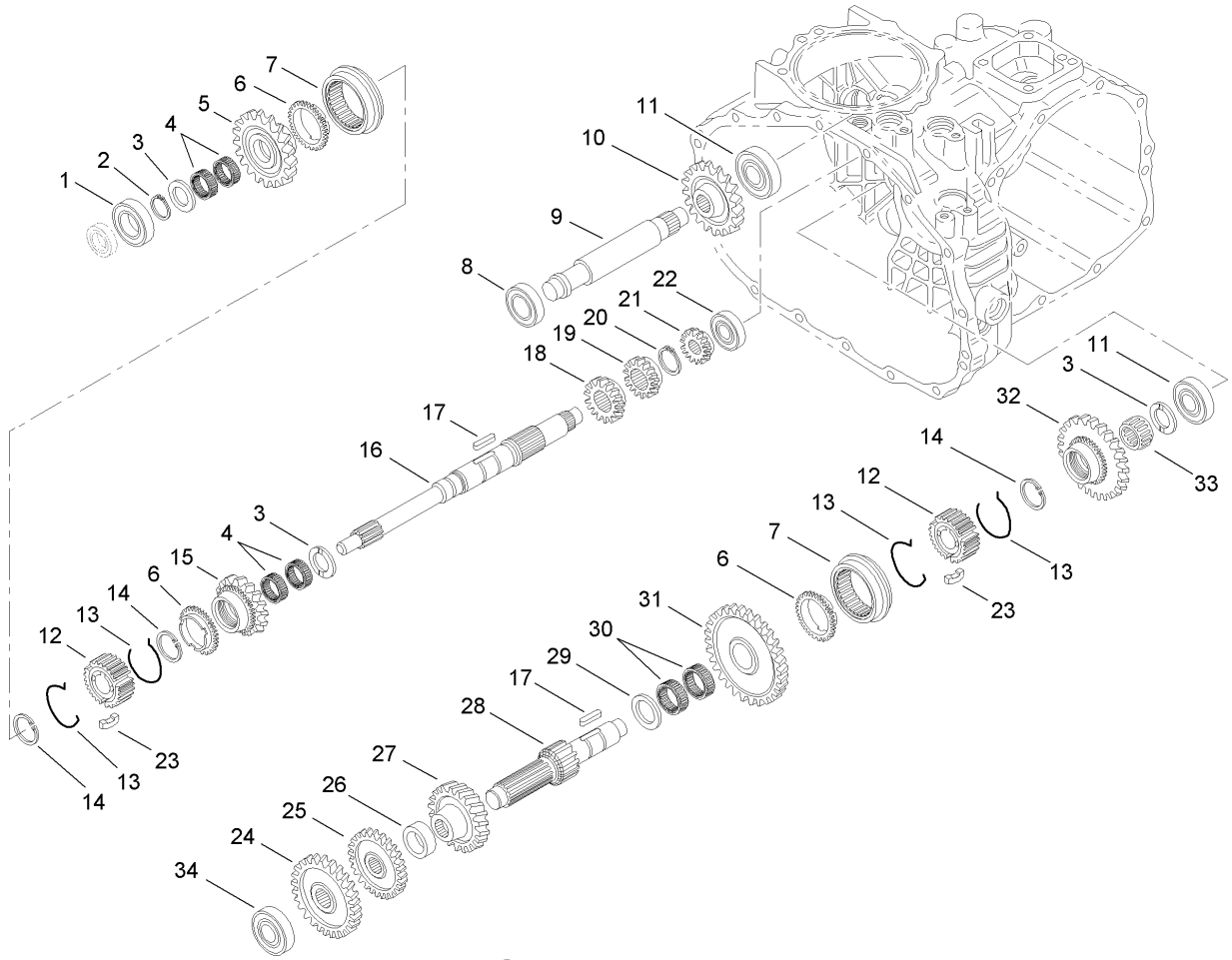

Gear Shaft Assembly Transaxle Assembly No. 105-4180

Ref	Part No.	Qty.	Description
1	251-8	1	Bearing-Ball
2	92-0753	1	Ring-Snap
3	92-0740	3	Washer-Thrust
4	92-0781	4	Bearing-Needle
5	110-2521	1	Gear-Main, 27T
6	92-0667	3	Ring-Synchro
7	92-0668	2	Shifter-Synchro
8	251-346	2	Bearing-Ball
9	92-0824	1	Shaft-Idler, Reverse
10	92-0684	1	Gear-Reverse, 33 Tooth
11	92-0778	2	Bearing
12	92-0664	2	Hub-Synchro
13	92-0666	4	Spring-Synchro
14	92-0763	3	Ring-Snap
15	110-2522	1	Gear- Main, 24T
16	92-0663	1	Shaft-Main
17	92-0772	2	Key
18	92-0687	1	Gear-Main, 16 Tooth
19	92-0672	1	Gear-Main, 18 Tooth
20	92-0754	1	Ring-Snap
21	92-0673	1	Gear-Main, 14 Tooth
22	92-0650	1	Bearing
23	92-0665	6	Key-Synchro
24	92-0822	1	Gear-Reduction, 28 Tooth

Ref	Part No.	Qty.	Description
25	92-0679	1	Gear-Reduction, H23 Tooth
26	92-0680	1	Collar
27	92-0823	1	Gear-Reduction, 43 Tooth
28	92-0674	1	Shaft-Reduction
29	92-0682	1	Washer-Thrust
30	92-0681	2	Bearing-Needle
31	110-2524	1	Gear- Reduction, 49T
32	92-0819	1	Gear-Reduction, 40 Tooth
33	92-0782	1	Bearing-Needle
34	105-7985	1	Bearing

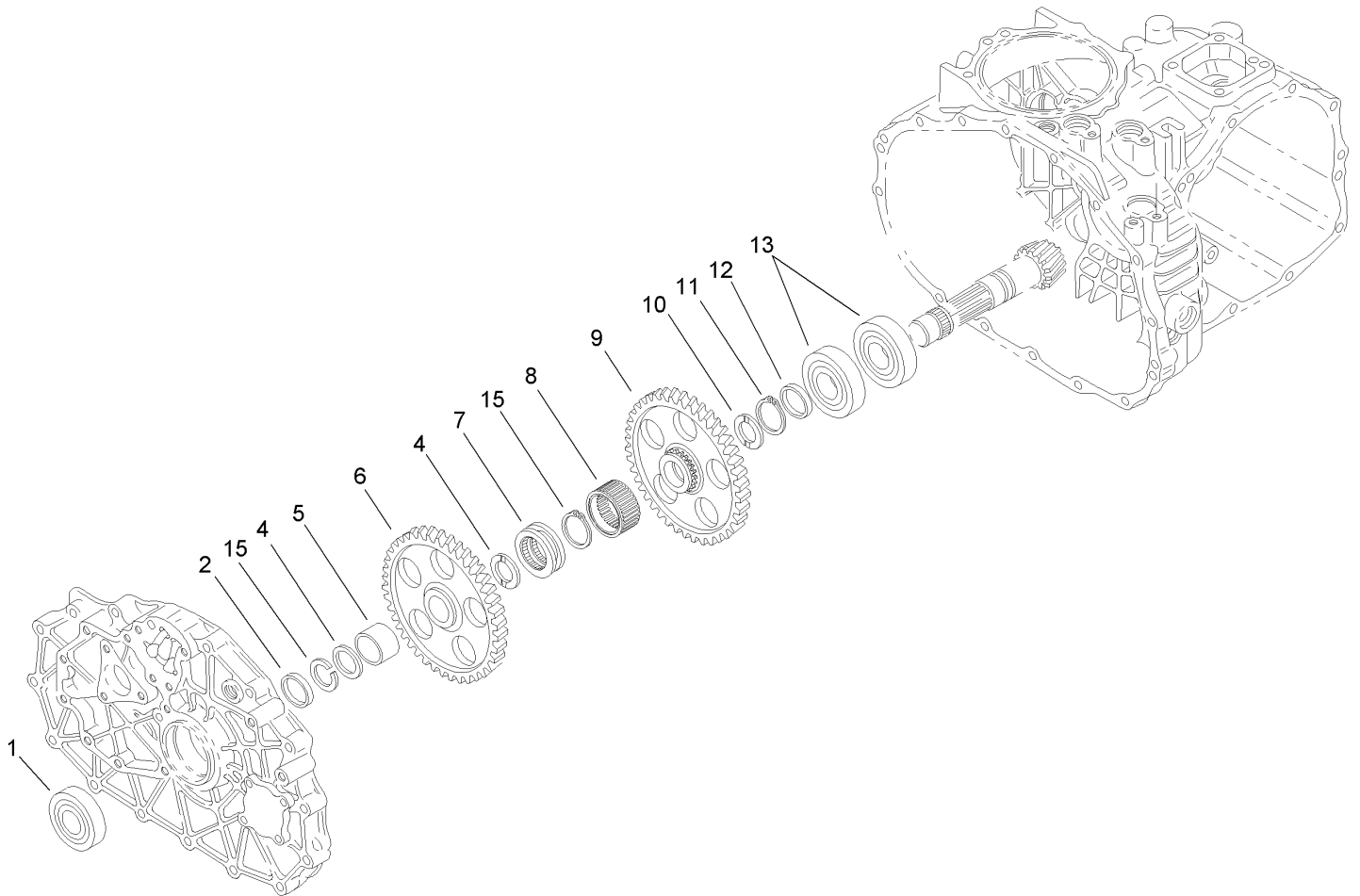

Countershaft Assembly Transaxle Assembly No. 105-4180

Ref	Part No.	Qty.	Description
1	92-0712	1	Bearing-Ball
2	92-0716	1	Collar
4	92-0711	2	Washer-Thrust
5	92-0783	1	Race-Inner
6	92-0715	1	Gear-Shaft, Counter
7	92-0718	1	Shifter
8	105-7986	1	Collar-Spline
9	92-0717	1	Gear-Shaft, Counter
10	92-0741	1	Washer-Thrust
11	92-0755	1	Ring-Snap
12	92-0713	1	Collar
13	92-0714	2	Bearing
15	105-7987	2	Ring-Snap

--	--	--	--

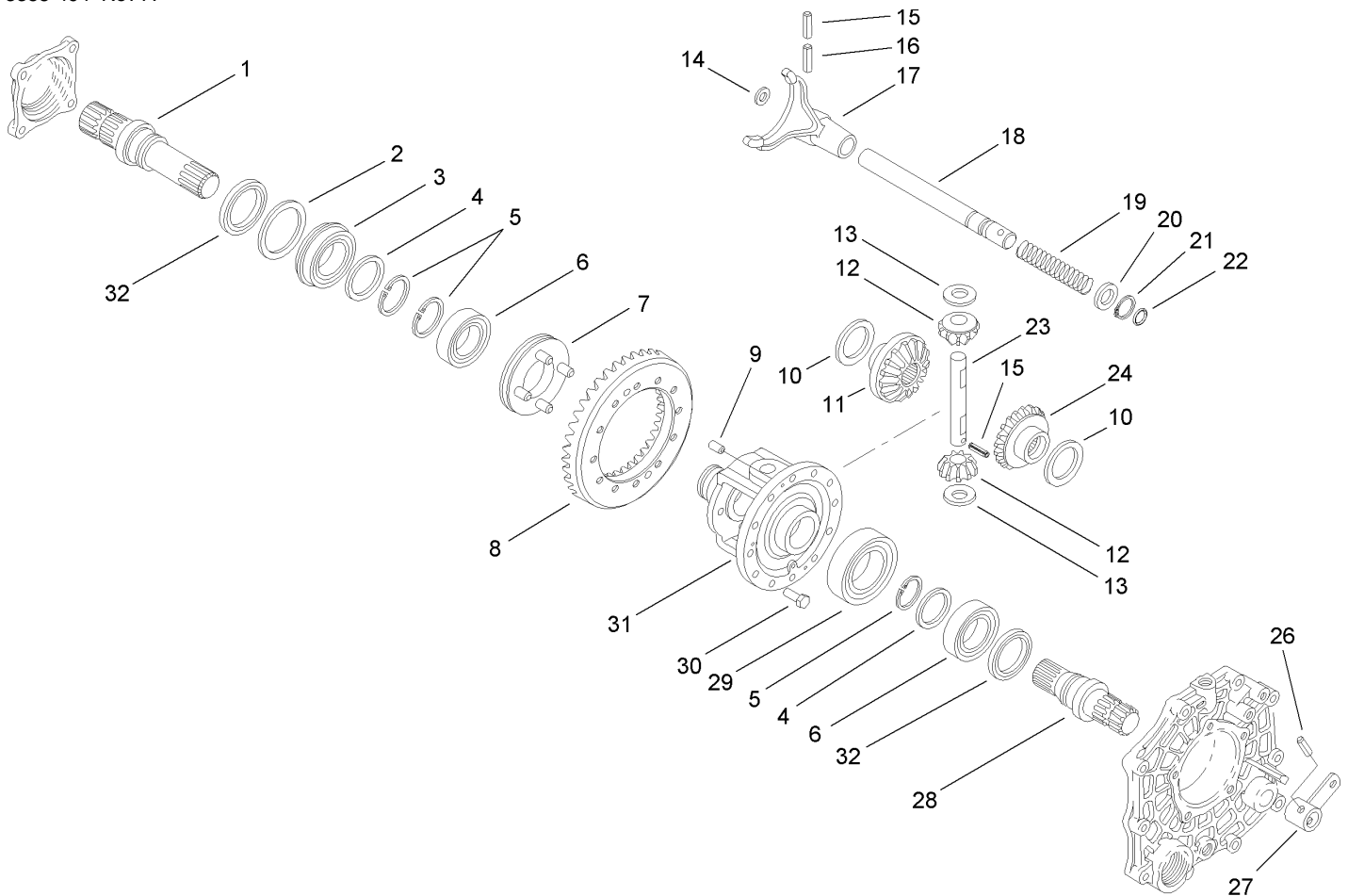

Differential Gear Assembly Transaxle Assembly No. 105-4180

Ref	Part No.	Qty.	Description
1	92-0726	1	Shaft-Axle, Right
2	92-0728	1	Washer
3	92-0780	1	Bearing
4	92-0727	2	Washer
5	92-0756	3	Ring-Snap
6	92-0775	2	Bearing
7	92-0730	1	Slider-Differential, Lock
8	105-7983	1	Countershaft And Ring Gear
9	92-0765	2	Pin-Parallel
10	92-0747	2	Side-Gear, Left Inner
11	92-0746	1	Gear-Side, RH
12	92-0748	2	Pinion-Differential
13	92-0750	2	Washer
14	92-0744	1	Washer
15	92-0768	2	Pin-Roll, Spring
16	92-0771	1	Pin-Roll, Spring
17	92-0721	1	Fork-Lock, Differential
18	92-0722	1	Shaft-Fork, Lock Differential
19	92-0723	1	Spring-Lock, Differential
20	92-0733	1	Washer
21	92-0753	1	Ring-Snap
22	92-0787	1	O-Ring
23	92-0749	1	Shaft-Pinion
24	92-0745	1	Gear-Side, LH

Ref	Part No.	Qty.	Description
26	92-0770	1	Pin-Roll, Spring
27	92-0724	1	Arm-Lock, Differential
28	92-0725	1	Shaft-Axle, Left
29	92-0776	1	Bearing
30	92-0803	12	Bolt
31	92-0720	1	Case-Differential
32	92-0793	2	Seal-Oil

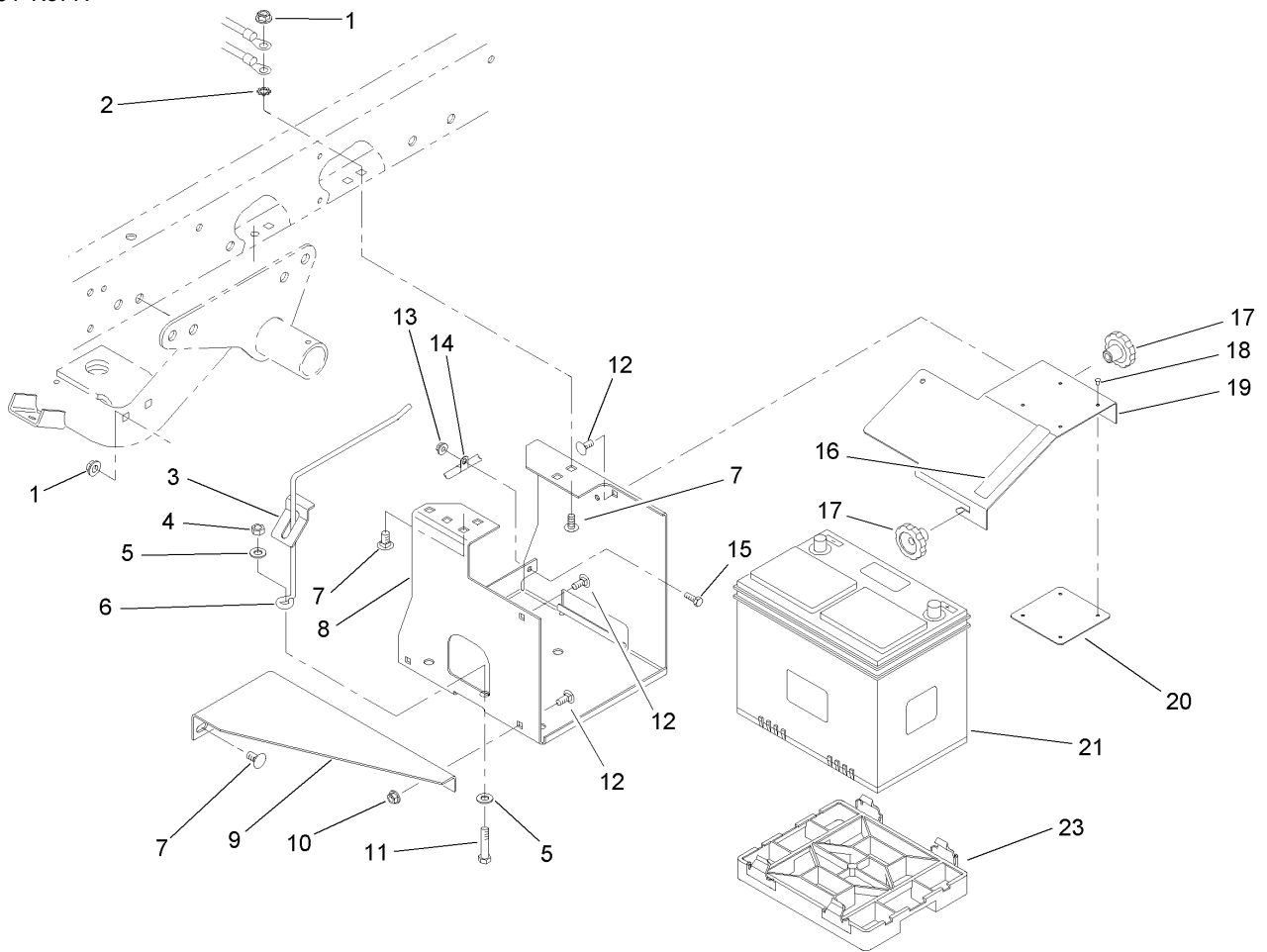

Battery Assembly

Ref	Part No.	Qty.	Description
1	3290-357	6	Nut-HHF, Whiz
2	3255-9	1	Washer-Lock
3	87-7610	1	Tab-Support, Battery
4	3296-39	1	Nut-Lock, NI
5	3256-24	2	Washer-Flat
6	87-7600	1	Rod-Support, Battery
7	3231-27	6	Screw-CARR
8	87-5120-03	1	Bracket-Holder, Battery
9	87-5110-03	1	Support-Base, Battery
10	32128-20	2	Nut-HF
11	323-9	1	Screw-HH
12	3230-23	4	Screw-CARR
13	32128-33	1	Nut-HF
14	2412-89	1	Clamp
15	321-4	1	Screw-HH
16	93-6687	1	Decal-No Step
17	19-4050	2	Knob
18	3269-27	4	Rivet-Snap
19	87-5130-03	1	Cover-Battery
20	87-7620	1	Shield-Terminal, Battery
21	106-5187	1	Battery
23	106-5188	1	Adapter-Height, Battery

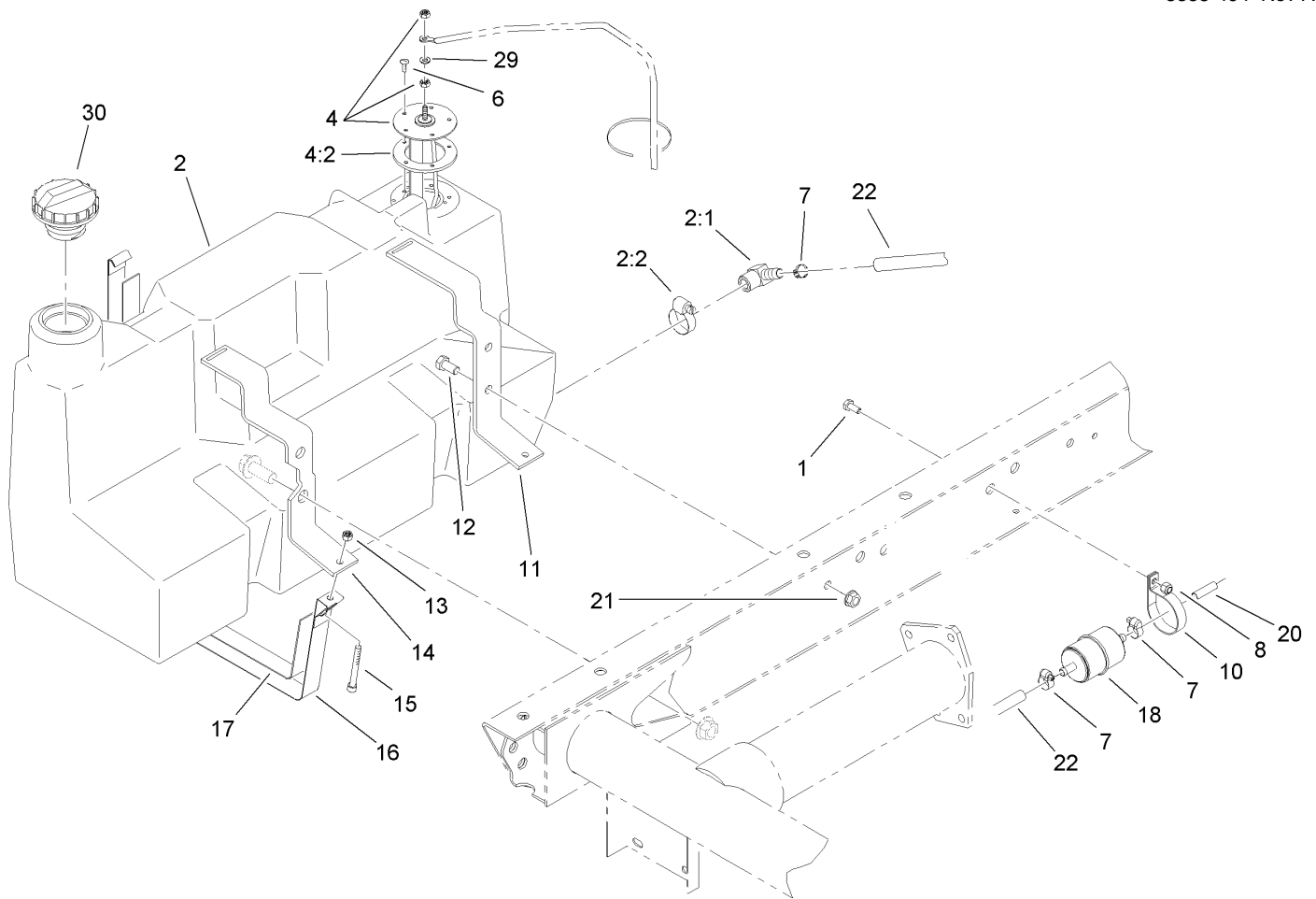

Fuel Tank Assembly

Ref	Part No.	Qty.	Description
1	321-3	1	Screw-HH
2	98-2919	1	Tank-Fuel
2:1	353-781	1	Fitting-Elbow
2:2	2412-36	1	Clamp-Hose
4	112-3170	1	Fuel Sender ASM
4:2	62-7650	1	Gasket
6	112-3169	5	Screw-HHF, Serrated
7	2412-108	4	Clamp-Worm
8	32128-33	1	Nut-HF
10	2412-148	1	Clamp-R
11	87-3140-03	1	Support-Gas Tank, Rear
12	323-4	2	Screw-HH
13	3296-42	2	Nut-Lock, NI
14	87-3150-03	1	Support-Gas Tank, Front
15	3274-54	2	Screw-HSH
16	87-3160	2	Strap-Tank, Gas
17	87-3170	2	Felt-Strap
18	108-3854	1	Filter-Fuel
20	109-0293	1	Hose-Fuel
21	3290-357	2	Nut-HHF, Whiz
22	109-0274	1	Hose-Fuel
29	5-3637	1	Spacer
30	93-3101	1	Cap-Fuel

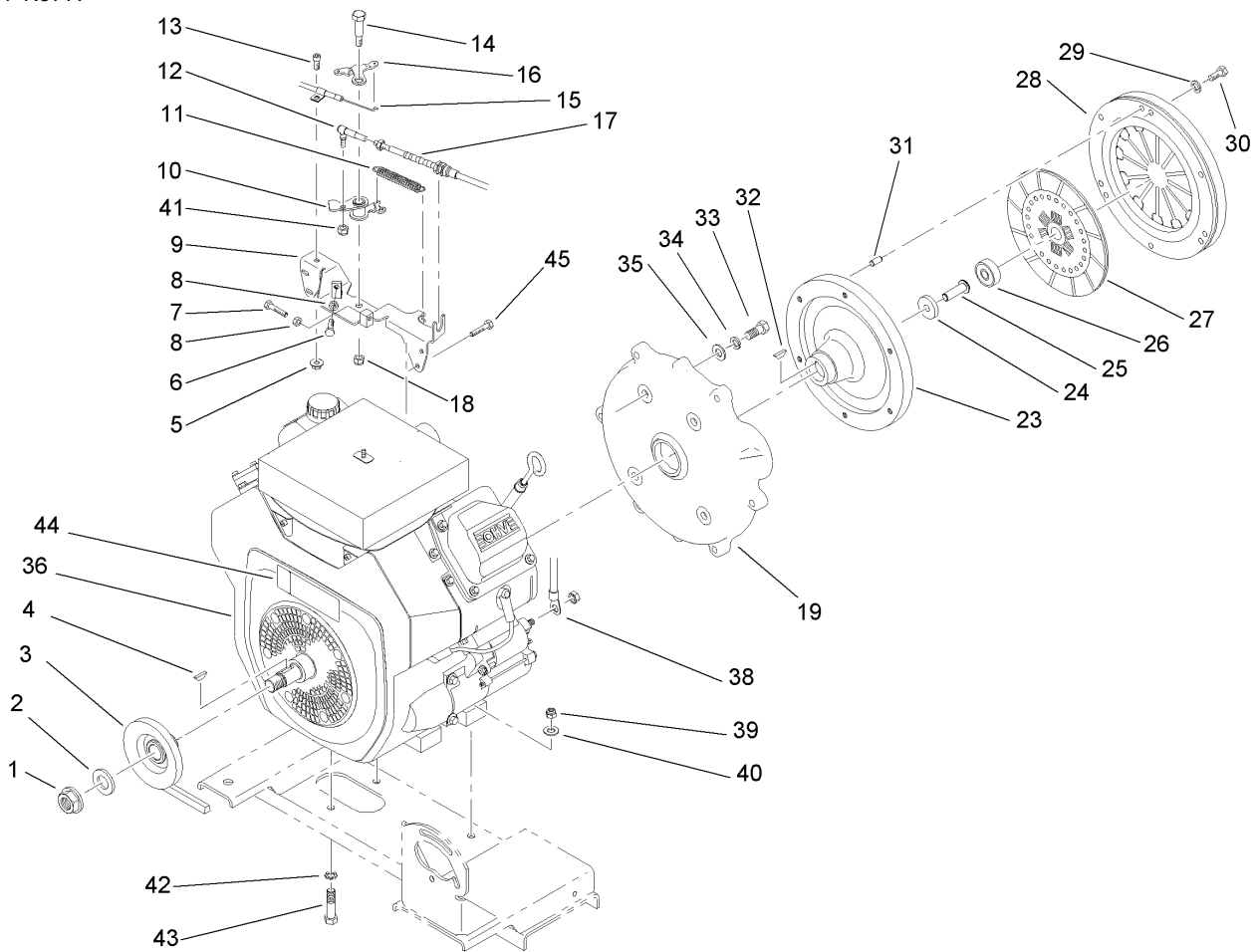

Engine Assembly

Ref	Part No.	Qty.	Description
1	3296-15	1	Nut-Lock, NI
2	3256-28	1	Washer-Flat
3	87-7710	1	Pulley ASM
4	3257-7	1	Key-Woodruff
5	32128-33	1	Nut-HF
6	329-6	1	Screw-HH
7	329-7	1	Screw-HH
8	3220-1	2	Nut-Jam
9	87-7780-03	1	Bracket-Throttle
10	87-7800	1	Lever-Throttle
11	67-1450	1	Spring-Idler
12	18-1720	1	Governor Ball Joint ASM
13	3274-15	1	Screw-HSH
14	7-0030	1	Bolt-Shoulder
15	106-7943	1	Cable-Control, Choke
16	87-7790	1	Lever-Choke
17	110-2539	1	Cable-Accelerator, Air-Cooled (Only On: 112-3216)
18	3296-29	1	Nut-Lock, NI
19	107-7991	1	Adapter-Clutch
23	87-6480	1	Flywheel
24	87-6080	1	Washer
25	3274-63	1	Screw-HSBH
26	87-6460	1	Bearing-Ball (W/Seal)

Ref	Part No.	Qty.	Description
27	104-9219	1	Disc-Clutch
28	104-9231	1	Plate-Pressure, Clutch
29	3253-4	6	Washer-Lock
30	33114-016	6	Screw-HH
31	42-7160	3	Pin
32	3257-5	1	Key-Woodruff
33	324-4	4	Screw-HH
34	3253-6	4	Washer-Lock
35	3256-25	4	Washer-Flat
36	105-4203	1	Engine-Kohler
38	87-8000	1	Cable-Battery, Positive
39	3296-39	4	Nut-Lock, NI
40	3256-24	4	Washer-Flat
41	3296-3	1	Nut-Lock
42	3255-9	1	Washer-Lock
43	323-9	4	Screw-HH
44	80-8040	1	Decal-Warning
45	32144-4	2	Screw-HWH

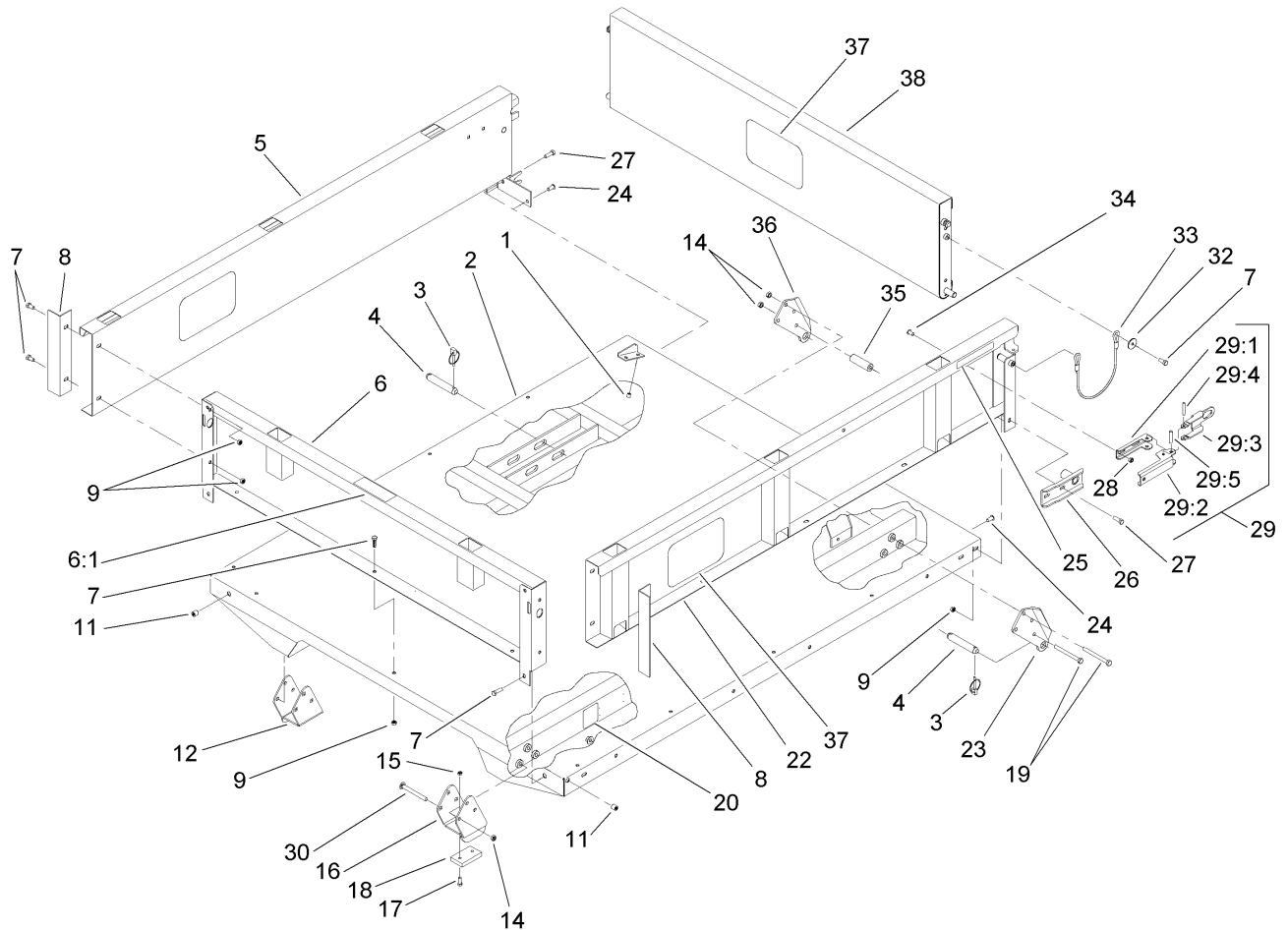

Full Bed and Side Panel Assembly

Ref	Part No.	Qty.	Description
1	32148-6	4	Insert-Nut
2	93-9724-03	1	Flatbed-Full
3	92-1298	8	Pin-Lynch
4	92-1233	4	Pin-Clevis
5	92-1255-03	1	RH Side Panel ASM
6	92-5982	1	Front Panel ASM
6:1	93-6689	1	Decal-No Riders
7	3234-7	21	Screw-HHF
8	92-1320-03	2	Angle-Side
9	104-8300	23	Nut-Flange, NI
11	32148-7	4	Nut-Insert
12	106-2423-03	1	RH Spacer Bracket ASM
14	3296-44	14	Nut-Lock, NI
15	3296-42	4	Nut-Lock, NI
16	106-2422-03	1	LH Spacer Bracket ASM
17	3250-45	4	Screw-SPH
18	93-9719	2	Block-Wear
19	323-42	8	Screw-HH
20	93-9899	2	Decal-Warning
22	92-1248-03	1	LH Side Panel ASM
23	93-9720-03	2	Bracket-Pivot, Long (LH)
24	3230-1	2	Bolt-CARR
25	93-9868	2	Decal-Caution
26	92-1265-03	2	Bracket-Pivot

Ref	Part No.	Qty.	Description
27	3234-29	6	Screw-HHF
28	32128-20	4	Nut-HF
29	99-1123	2	Latch ASM
29:1	92-1271	1	Pivot-Latch
29:2	99-1113	1	Handle-Latch
29:3	99-1112	1	Plate-Retainer
29:4	32121-78	1	Pin-Roll
29:5	32121-25	1	Pin-Roll
30	3231-24	6	Screw-CARR
32	3256-57	4	Washer-Flat
33	93-9595	2	Lanyard
34	3230-15	4	Screw-CARR
35	93-9575	2	Tube-Pivot, Flatbed
36	93-9721-03	2	Bracket-Pivot, Long (RH)
37	105-4222	3	Decal
38	92-1259-03	1	Tailgate-Rear

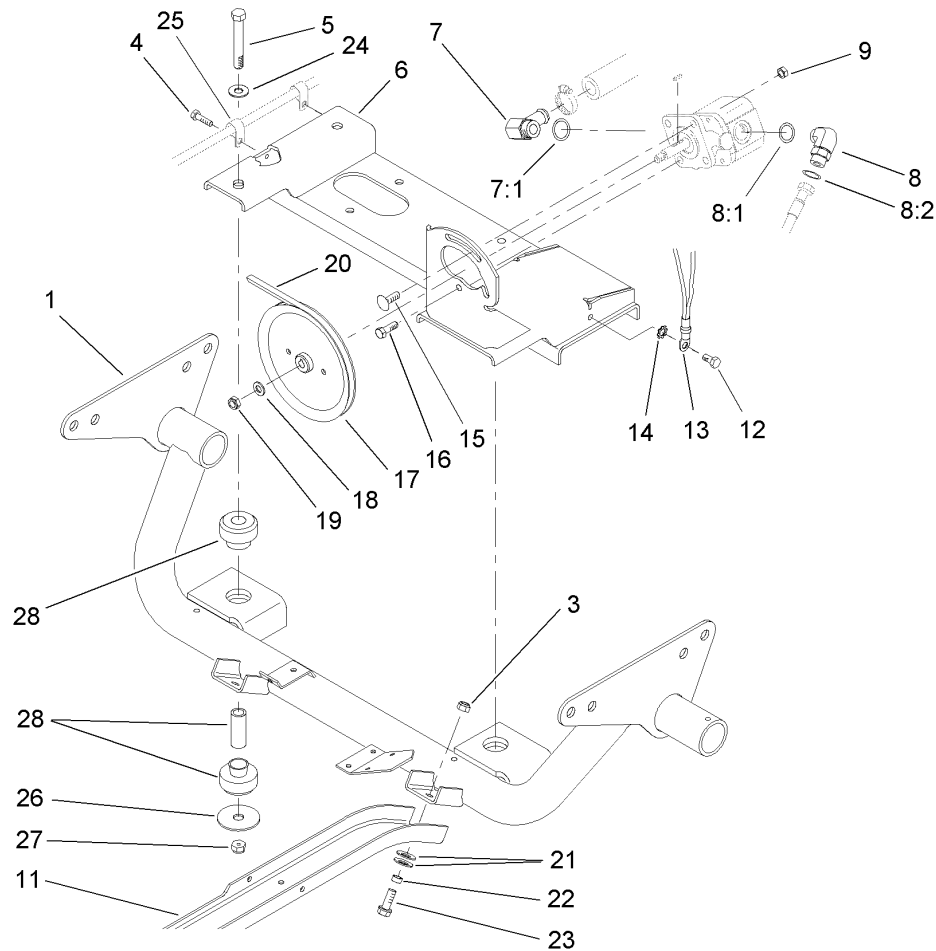

Engine Support Assembly

Ref	Part No.	Qty.	Description
1	87-8150-03	1	Engine Support ASM
3	3296-39	6	Nut-Lock, NI
4	32144-10	2	Screw-HWH
5	324-12	2	Screw-HH
6	87-6400-03	1	Engine Mount ASM
7	87-8170	1	Fitting
7:1	237-80	1	O-Ring
8	340-18	1	Fitting-HYD, 90 DEG
8:1	237-79	1	O-Ring
8:2	237-22	1	O-Ring
9	3296-29	2	Nut-Lock, NI
11	87-4730-03	2	Guard-Belly
12	32144-14	1	Screw-HWHTF
13	87-3080	1	Cable-Battery, Negative
14	3255-8	1	Washer-Lock
15	3230-22	1	Screw-CARR
16	322-5	1	Screw-HH
17	87-7740	1	Pulley
18	3256-45	1	Washer-Flat
19	3296-5	1	Nut-Lock
20	87-8370	1	V-Belt
21	3290-413	12	Washer-Belleville
22	76-9100	6	Spacer-Speed, Reel
23	3234-11	6	Screw-HHF

Ref	Part No.	Qty.	Description
24	3256-25	2	Washer-Flat
25	2412-89	2	Clamp
26	87-5100	2	Washer-Snubbing
27	3296-48	2	Nut-Lock, NI
28	106-7865	2	Engine Mount ASM

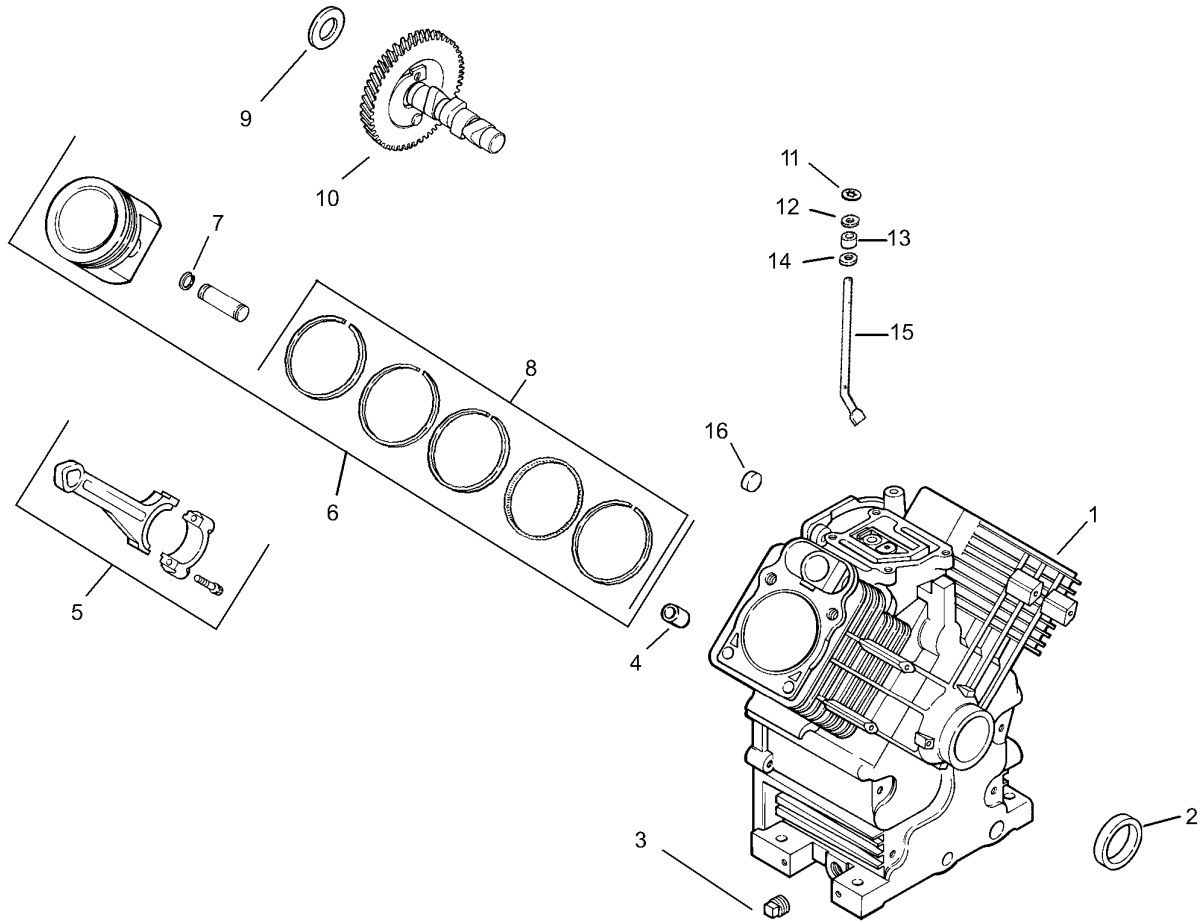

Crankcase Assembly Kohler CH23-76548

Ref	Part No.	Qty.	Description
1		1	Crankcase (Use Short Block Or Miniblock)
2	24 032 01-S	1	Seal-Oil
3	25 139 57-S	2	Plug-Square Head Solid (.38)
4	24 380 13-S	6	Pin-Locating
5	24 067 13-S	2	Rod-Connecting (Standard)
6	24 067 14-S	2	Rod-Connecting (.25)
7	24 874 09-S	2	Piston W/Ring Set (STD.)(Incl. Ref. #7 And 8)
8	24 874 10-S	2	Piston W/Ring Set (.25)
9	24 874 11-S	2	Piston W/Ring Set (.50)
10	24 874 15-S	2	Piston W/Ring Set (.08)
11	24 018 01-S	4	Retainer-Piston, Pin
12	24 108 08-S	2	Ring Set (STD And .08)
13	24 108 09-S	2	Ring Set (.25)
14	24 108 10-S	2	Ring Set (.50)
15	12 422 09-S	1	Shim-Camshaft (Red .032)
16	12 422 13-S	1	Shim-Camshaft (Black .04)
17	12 422 07-S	1	Shim-Camshaft (White .028)
18	12 422 08-S	1	Shim-Camshaft (Blue .03)
19	12 422 10-S	1	Shim-Camshaft (Yellow .034)
20	12 422 11-S	1	Shim-Camshaft (Green .036)
21	12 422 12-S	1	Shim-Camshaft (Gray .038)
22	24 012 10-S	1	Camshaft

Ref	Part No.	Qty.	Description
23	24 018 09-S	1	Ring-Retainer
24	M-931010-S	1	Washer-Flat (8 Mm)
25	28 032 09-S	1	Seal-Shaft, Cross Governor
26	24 468 15-S	1	Washer-Flat (.34)
27	24 144 33-S	1	Shaft-Governor Cross
28	52 139 09-S	1	Plug-Cup

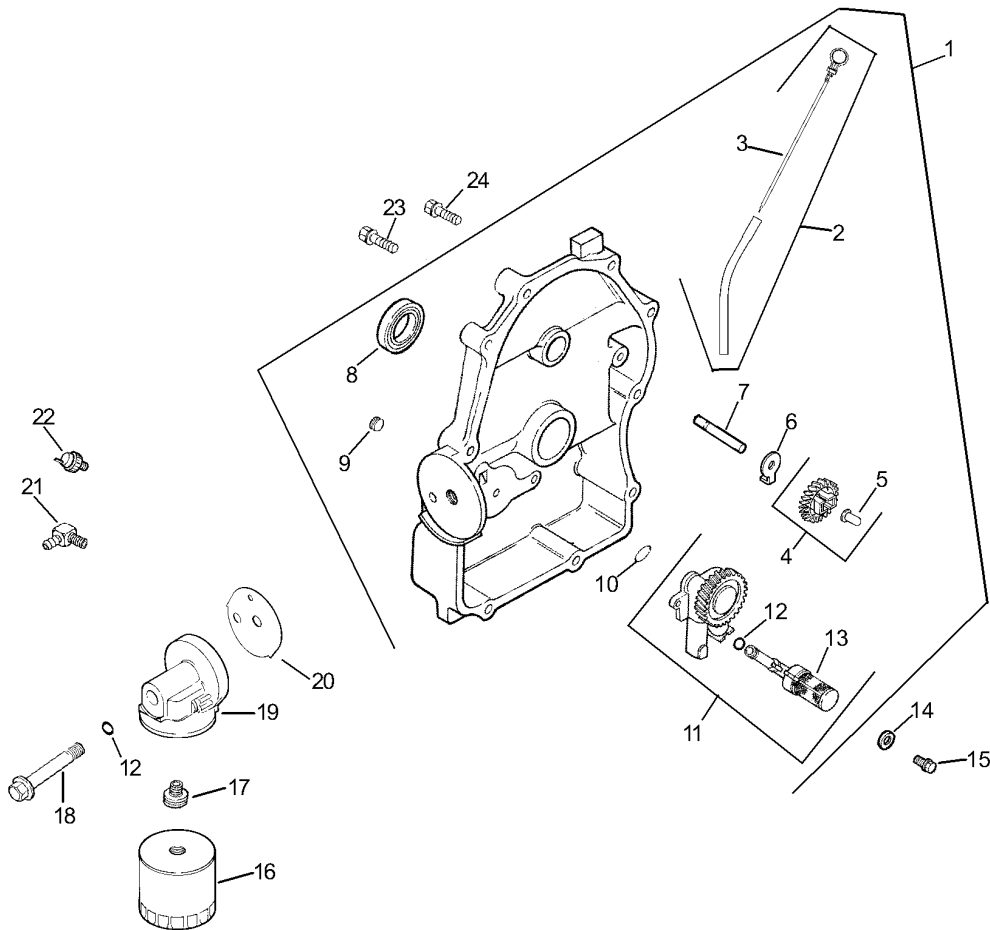

Oil Pan / Lubrication Assembly Kohler CH23-76548

Ref	Part No.	Qty.	Description
❶1	24 009 83-S	1	Plate, Closure ASM. (Incl. Ref. #2-13)
❶2	24 755 121-S	1	Tube ASM., Dipstick (Incl. Ref. #3)
❶3	24 038 10-S	1	Dipstick
❶4	24 043 12-S	1	Kit, Governor Gear (Incl. Ref. #5)
❶5	12 380 01-S	1	Pin-Regulating, Governor
❶6	52 448 02-S	1	Tab-Locking
❶7	12 144 02-S	1	Shaft-Gear, Governor
❶8	52 032 08-S	1	Seal-Oil
❶9	25 139 60-S	2	Plug-Hex, Countersunk (.125)
❶10	24 153 08-S	1	O-Ring
❶11	24 393 10-S	1	Oil Pump Assembly (Incl. Ref. #12,13)
❶12	24 153 01-S	1	O-Ring
❶13	24 381 04-S	1	Pick Up-Oil
❶14	M-631005-S	2	Washer-Plain (6 Mm)
❶15	M-645025-S	2	Screw-HF (M6X1.0X25)
❶16	12 050 01-S	1	Filter-Oil
❶17	24 136 01-S	1	Nipple-Filter, Oil
❶18	24 211 01-S	1	Bolt-Oil Filter Adapter
❶19	23 029 01-S	1	Adapter, Oil Filter
❶20	24 04129-S	1	Gasket, Oil Filter Adapter
❶21	25 155 02-S	1	Connector-Hose, 90 DEG
❶22	25 099 24-S	1	Switch-Pressure

Ref	Part No.	Qty.	Description
❶23	24 086 16-S	9	Screw-HF (M8X1.25X45)
❶24	24 086 17-S	1	Screw-HF (M8X1.25X45)
❶❶	25 113 05-S	1	Decal-Sentry, Oil

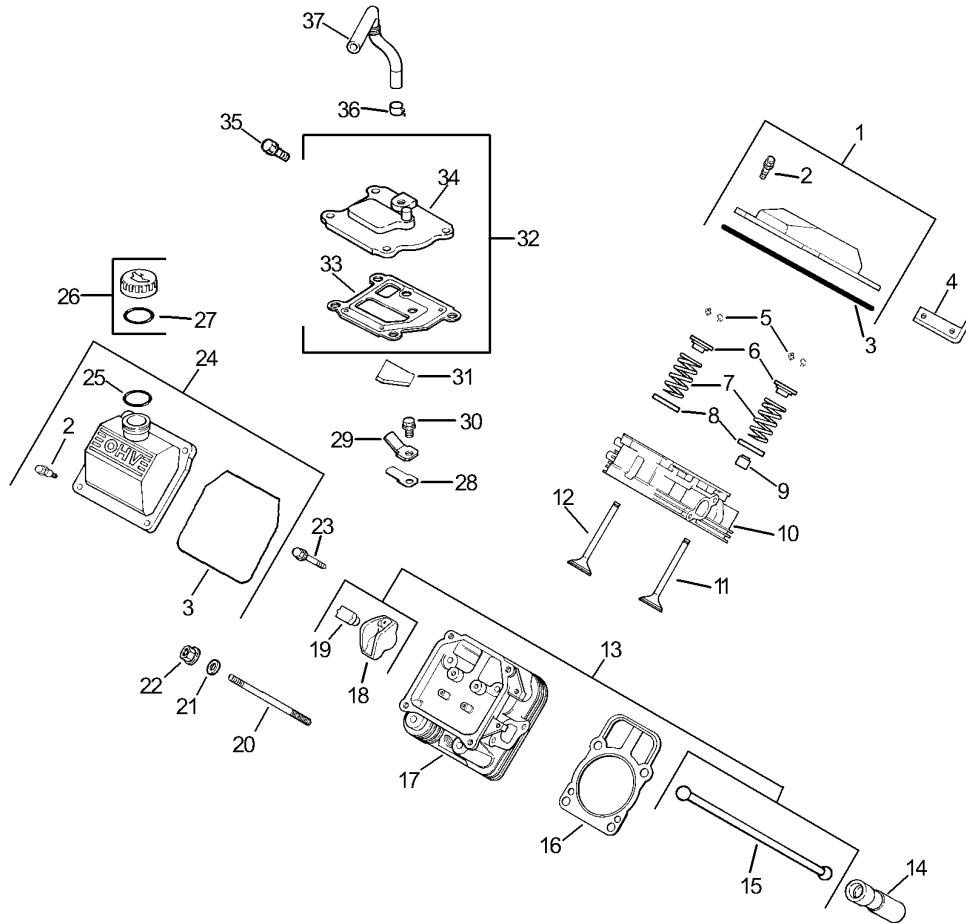

Head / Valve / Breather Assembly Kohler CH23-76548

Ref	Part No.	Qty.	Description
❶	24 755 74-S	1	Kit, Valve Cover-Plain (Incl. Ref. #2 And 3)
❷	24 086 32-S	4	Screw-Shoulder, M6X1.0X30
❸	24 153 16-S	1	O-Ring
❹	24 455 01-S	2	Strap-Lifting
❺	12 755 03-S	4	Retainer Kit
❻	12 173 01-S	4	Cap-Spring, Valve
❼	24 089 02-S	4	Spring-Valve
❽	235011-S	4	Retainer-Spring
❾	66 032 05-S	2	Seal-Stem, Valve
❿	24 318 68-S	1	No. 1 Cylinder Head ASM
⓫	24 017 01-S	2	Valve-Intake (Standard)
⓬	24 017 02-S	2	Valve-Intake (.25)
⓭	24 016 01-S	2	Valve-Exhaust (Standard)
⓮	24 016 02-S	2	Valve-Exhaust (.25)
⓯	24 755 66-S	1	Kit, Valve Train (Incl. Ref. # 15,18,19)
⓰	25 351 01-S	4	Lifter-Valve
⓱	24 411 05-S	4	Rod-Push
⓲	24 041 40-S	2	Gasket-Cylinder Head
⓳	24 318 71-S	1	No. 2 Cylinder Head ASM
⓴	25 186 01-S	4	Arm-Rocker
⓵	24 599 01-S	4	Pivot-Arm, Rocker
⓶	24 072 09-S	8	Stud (M8X1.25, M10X1.5, 105 Mm)

Ref	Part No.	Qty.	Description
⓷	24 468 16-S	8	Washer-Flat (8.6 Mm)
⓸	24 100 10-S	8	Nut-HF (M8X1.25)
⓹	M-640034-S	4	Screw-HF (M6X1.0X34)
⓺	24 755 75-S	1	Kit, Valve Cover Oil Fill (Incl. Ref. #2,3,25)
⓻	24 153 09-S	1	O-Ring
⓼	24 755 46-S	1	Kit, Oil Fill Cap (Incl. Ref. #27)
⓽	24 153 03-S	1	"o"ring
⓾	24 402 03-S	1	Reed-Breather
⓿	12 018 01-S	1	Retainer-Reed, Breather
⓿	M-545010-S	1	Screw-HHFTF (M5X0.8X10)
⓫	24 050 01-S	1	Filter-Breather
⓫	24 033 01-S	1	Kit, Breather (Incl. Ref. #33, 34)
⓫	24 041 23-S	1	Gasket-Breather
⓫	24 096 58-S	1	Cover-Breather
⓫	M-645020-S	4	Screw-Flange, Hex (M6X1.0X20)
⓫	25 237 14-S	2	Clamp-Hose
⓫	24 326 26-S	1	Hose-Breather

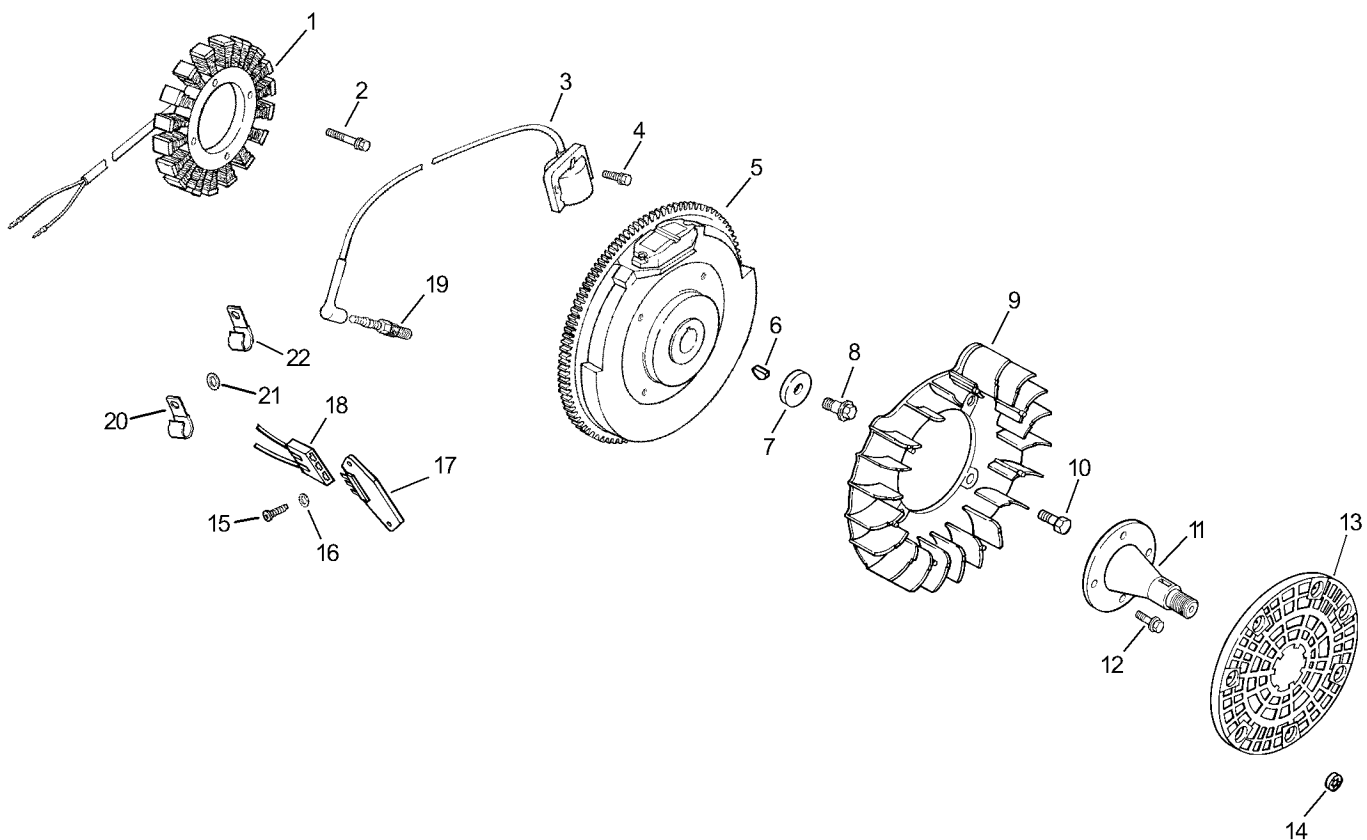

Ignition / Electrical Assembly Kohler CH23-76548

Ref	Part No.	Qty.	Description
❶	28 085 02-S	1	Stator Kit
❷	M-545030-S	2	Screw-Cap, Hex
❸	24 584 01-S	2	Module-Ignition
❹	M-545020-S	4	Screw-HHFTF (M5X0.8X20)
❺	24 025 01-S	1	Flywheel
❻	X-42-15-S	1	Key (.19 X .62)
❼	12 468 03-S	1	Washer-Flat (.38)
❽	12 086 14-S	1	Screw-Hex, Flange (M10X1.5X45)
❾	24 157 01-S	1	Fan
❿	25 086 47-S	4	Bolt-Shoulder (M6X1.0X16)
⓫	24 144 17-S	1	Shaft-Front Drive
⓬	M-839025-S	4	Screw-HF (M8X1.25X25)
⓭	24 162 16-S	1	Screen-Grass
⓮	24 018 03-S	3	Retainer
⓯	24 086 18-S	2	Screw-Phl HD (11-16X.88)
⓰	X-25-92-S	2	Washer-Plain
⓱	25 403 03-S	1	Rectifier-Regulator, 15 Amp
⓲	236602-S	1	Connector (3 Contact)
⓳	12 132 02-S	2	Spark Plug
⓴	235173-S	1	Clip-Cable
⓵	X-25-63-S	1	Washer-Flat (.25)
⓶	48 154 02-S	1	Clip-Cable
⓷	24 518 12-S	1	Lead-Black
⓸	X-22-11-S	1	Washer-Lock, Internal Tooth (1/4)

Ref	Part No.	Qty.	Description
⓷	24 176 92-S	1	Harness-Wiring
⓸	24 518 34-S	1	Lead
⓹	25 454 03-S	3	Tie-Wire

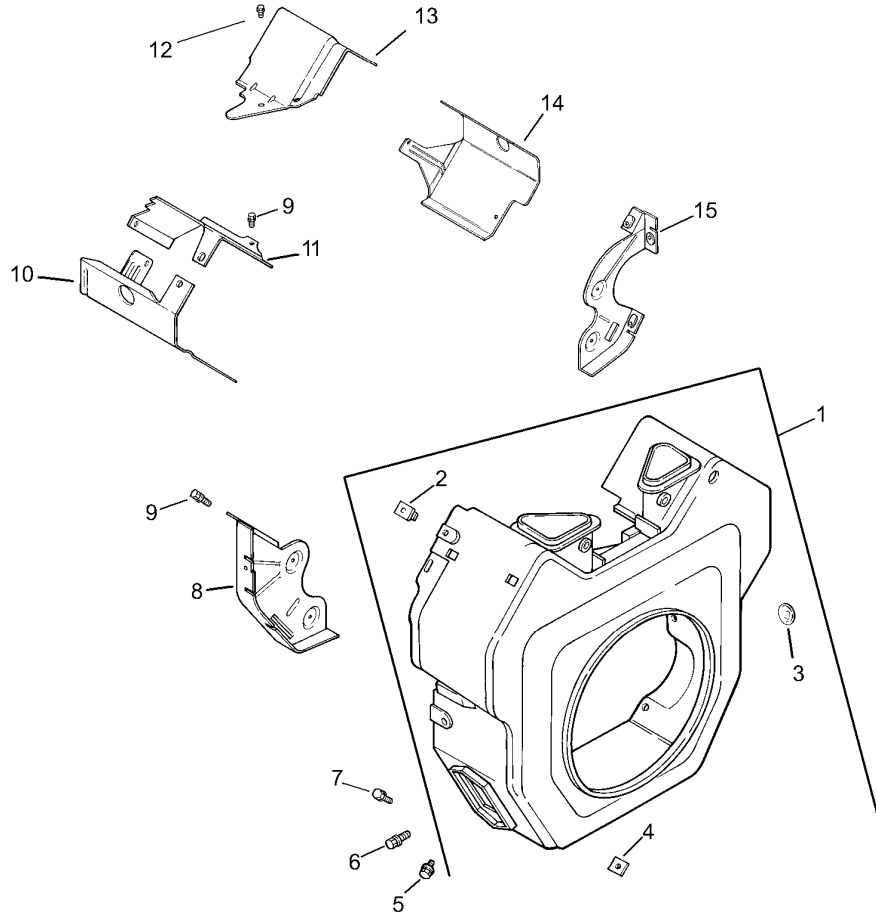

Blower Housing and Baffle Assembly Kohler CH23-76548

Ref	Part No.	Qty.	Description
❶	24 027 20-S	1	Housing, Blower (Incl. Ref. #2-4)
❷	24 100 02-S	2	Nut-Plastic
❸	25 139 16-S	1	Plug-Button (.56)
❹	24 100 01-S	2	Nut-Plastic
❺	M-551016-S	1	Screw-Heavy Hex Flange (M5X0.8X16)
❻	M-545016-S	3	Screw-HHFTF (M5X0.8X16)
❼	M-545020-S	4	Screw-HHFTF (M5X0.8X20)
❽	24 146 16-S	1	Plate-Backing, No. 2 Side
❾	M-645016-S	6	Screw-HHFTF (M6X1.0X16)
❿	24 063 20-S	1	Baffle-Cylinder Barrel, No. 2 Side
⓫	24 063 17-S	1	Baffle-Valley (No. 2 Side)
⓬	M-545010-S	2	Screw-HHFTF (M5X0.8X10)
⓭	24 063 24-S	1	Baffle-Valley, No. 1 Side
⓮	24 063 58-S	1	Baffle-Barrel, Cylinder (No. 1 Side)
⓯	24 146 20-S	1	Plate-Backing (No. 1 Side)
⓰	24 113 81-S	1	Decal-23 Hp

--	--	--	--

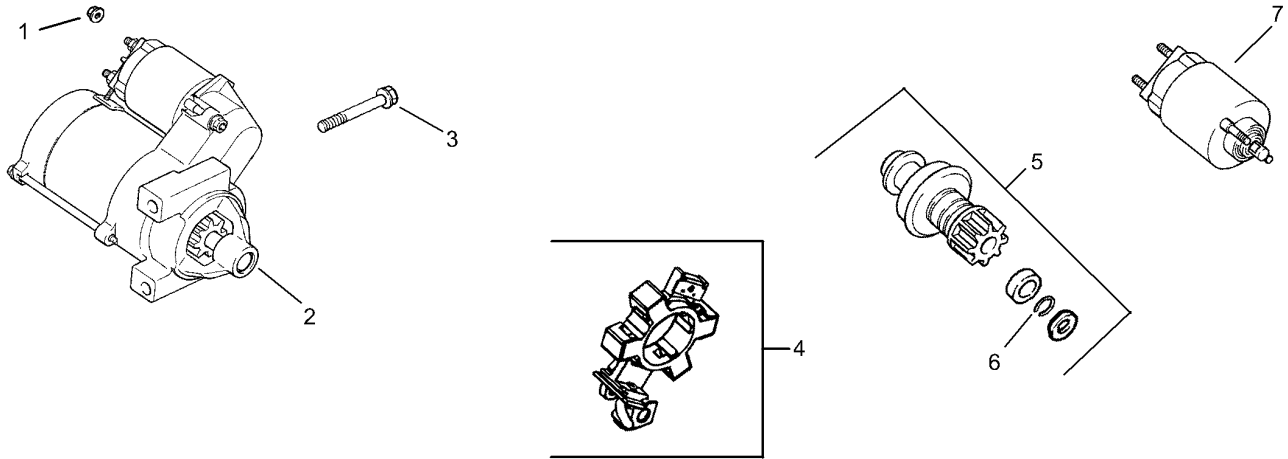

Starting System Assembly Kohler CH23-76548

Ref	Part No.	Qty.	Description
①	M-841080-S	1	Nut-Hex, Flange (M8X1.25)
②	25 098 08-S	1	Starter, Solenoid Shift ASM. (Incl. Ref. #4-7)
③	M-839080-S	2	Screw-Hex, Flange (M8X1.25X70)
④	25 225 01-S	1	Brush Kit
⑤	25 755 33-S	1	Kit, Pinion Drive (Incl. Ref. #6)
⑥	25 141 05-S	1	Ring-Retaining
⑦	25 435 04-S	1	Solenoid Kit

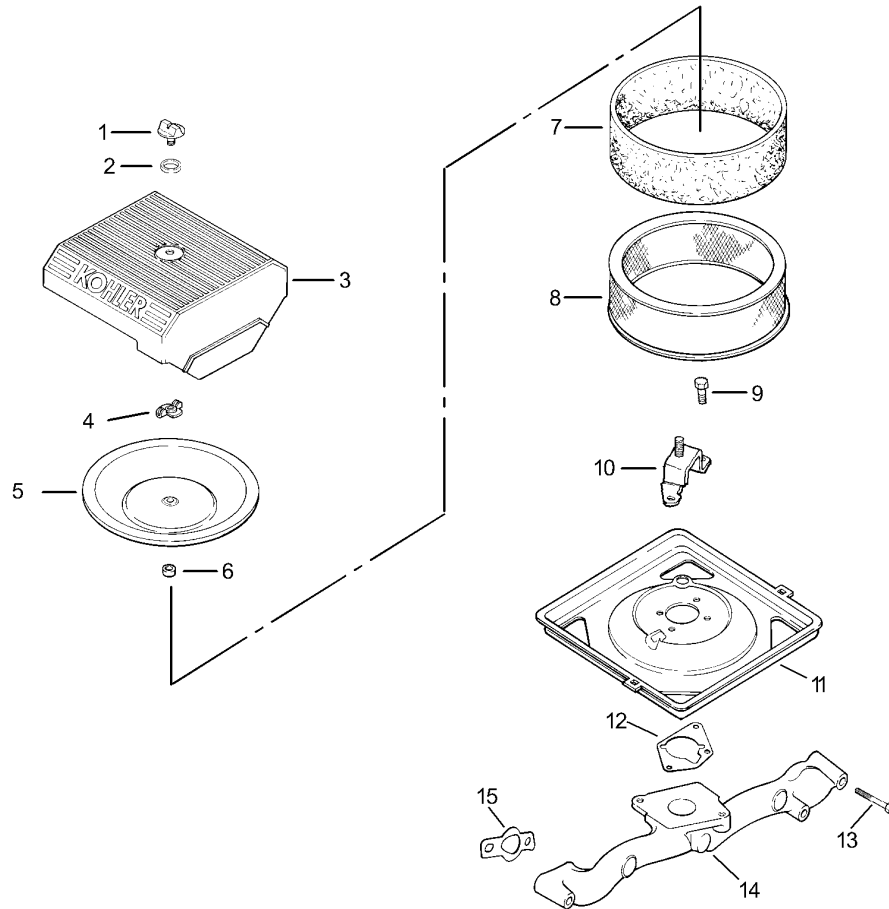

Air Intake / Filtration Assembly Kohler CH23-76548

Ref	Part No.	Qty.	Description
❶	25 341 03-S	1	Knob-Cover
❷	24 153 20-S	1	Seal
❸	24 096 67-S	1	Cover-Cleaner, Air
❹	12 100 01-S	1	Nut-Wing
❺	24 096 01-S	1	Cover-Air Cleaner, Inner
❻	230046-S	1	Seal
❼	24 083 05-S	1	Element-Precleaner
❽	24 083 03-S	1	Element-Cleaner, Air
❾	M-645016-S	3	Screw-HHFTF (M6X1.0X16)
❿	24 126 88-S	1	Bracket-Cleaner, Air
⓫	24 094 11-S	1	Base, Air Cleaner
⓬	24 041 06-S	1	Gasket-Base, Air Cleaner
⓭	25 086 84-S	4	Screw-HF (M6X1.0X55)
⓮	24 164 14-S	1	Manifold-Intake
⓯	24 041 01-S	2	Gasket-Manifold, Intake

--	--	--	--

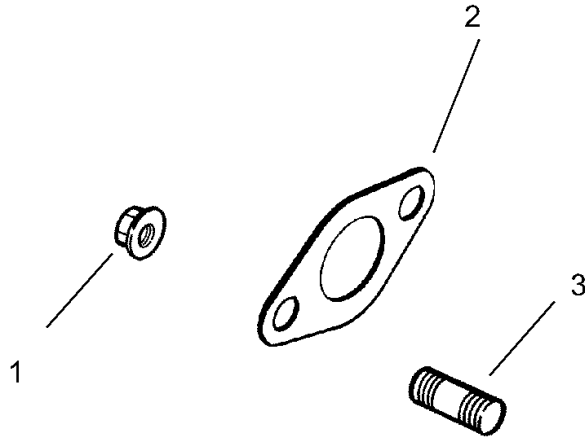

Exhaust Assembly Kohler CH23-76548

Ref	Part No.	Qty.	Description
①	M-841080-S	4	Nut-Hex, Flange (M8X1.25)
②	24 041 02-S	2	Gasket-Exhaust
③	25 072 04-S	4	Stud (M8X1.25X33)
①②	24 755 107-S	1	Gasket Set

--	--	--	--

Attachments and Accessories

For 07363 - Workman 3100 with Bed

Product Name	Model/Part
Full Area Flatbed	07301
Full Area Flatbed Side Kit	07302
Fold Down Side Kit	07303
Cab Kit with Doors	07319
2/3 Area Flatbed	07321
2/3 Area Flatbed Side Kit	07322
Bed Liner	07331
Sunshade Kit	07332
Fold-down Windshield Kit	07333
1/3 Area Flatbed	07341
1/3 Area Stake Side Kit	07342
1/3 Area Platform Lift	07344
Rear PTO Kit	07419
Hand Throttle Kit	07420
Spiker	08856
Finish Grader	08867
Red Gas Cap	107-2173
Tachometer Kit	107-7977
Signal Light Kit	107-7985
Accessory Wire Harness Kit	107-7987
Work Light Kit	107-7988
Remote Hydraulics Float Kit	107-8004
Backup Alarm Kit	107-8037
Side Mirror Kit	107-8048
Premium Engine Oil, 10w30 (Drum)	108-1179
Premium Engine Oil, 10w30 (Pail)	108-1180
Premium ATF Drum	108-1185
Premium ATF Pail	108-1186
Premium All Purpose Grease	108-1190
Arrestor-Spark	108-3108
Mirror Kit	110-2510
Single Nozzle Kit	41024
Hose Reel Kit	41097
Spray Gun Kit	41133
Pro Foam Concentrate (4 X 1 Gallon)	41157
Foam Marker Kit	41228
Workman 200 Spray System	41235
Enclosed Boom	41355
Enclosed Walking Boom	41358
Enclosed Walking Boom Trailer	41359
Enclosed Boom Mount	41363
Power Holster Hitch Kit	44209
Drawbar Kit	44212
Hitch Frame and Draw Bar Kit	44213
Topdresser 1800	44225
Fifth Wheel Hitch Kit	44230
Core Harvester Adapter Kit	44242
Rear Tire And Wheel ASM	87-5370
23 Inch Rear Fender Kit	87-5420
24 Inch Rear Fender Kit	87-5430
Tire-Rear	87-6740
Speedometer Tachometer Kit	87-9960

Attachments and Accessories (continued)

For 07363 - Workman 3100 with Bed

Product Name	Model/Part
1/3 Area Tool Box Mounting Kit	92-1219
Automatic Tailgate Release Kit	92-1220
Block-Fuse	92-2641
PTO Over Running Clutch Kit	92-2655
Topdresser 1800 Lift Kit	92-4452
Mid-Mount Kit for Platform Lift	93-3741
1/3 Area Cover Kit	93-9225
Rear 1/3 Area Mounting Kit	93-9249
Tire-Front, Service	94-3809
Tire-Front	94-5261
Rear Wheel ASM	98-2978
Wheel And Tire Kit	98-2992
Tire-Rear	98-2993
Tire-Rear, Industrial	99-1091
Rear Tire ASM	99-1093

NOTES

