



Count on it.

Operator's Manual

**Commercial Walk-Behind Mower
with Floating Deck, T-Bar, Hydro with 36in,
40in, 48in or 52in TURBO FORCE® Cutting
Unit**

Model No. 30494—Serial No. 27000001 and Up

Model No. 30496—Serial No. 27000001 and Up

Model No. 30498—Serial No. 27000001 and Up

Model No. 30499—Serial No. 27000001 and Up

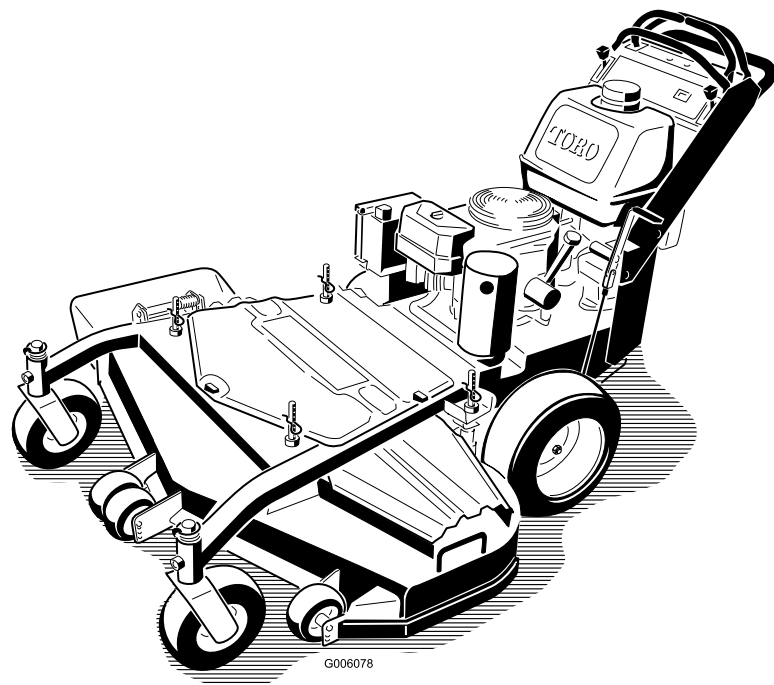

G006078

Warning

CALIFORNIA Proposition 65 Warning

The engine exhaust from this product contains chemicals known to the State of California to cause cancer, birth defects, or other reproductive harm.

This spark ignition system complies with Canadian ICES-002.

Important: This engine is not equipped with a spark arrester muffler. It is a violation of California Public Resource Code Section 4442 to use or operate the engine on any forest-covered, brush-covered, or grass-covered land. Other states or federal areas may have similar laws.

The enclosed *Engine Owner's Manual* is supplied for information regarding the US Environmental Protection Agency (EPA) and the California Emission Control Regulation of emission systems, maintenance, and warranty. Replacements may be ordered through the engine manufacturer.

Introduction

Read this information carefully to learn how to operate and maintain your product properly and to avoid injury and product damage. You are responsible for operating the product properly and safely.

You may contact Toro directly at www.Toro.com for product and accessory information, help finding a dealer, or to register your product.

Whenever you need service, genuine Toro parts, or additional information, contact an Authorized Service Dealer or Toro Customer Service and have the model and serial numbers of your product ready. Figure 1 identifies the location of the model and serial numbers on the product. Write the numbers in the space provided.

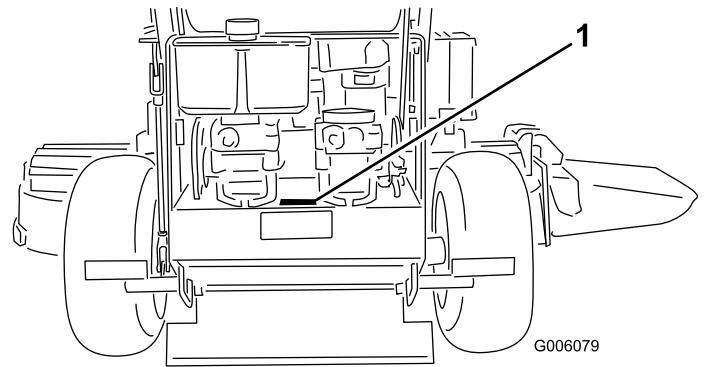

Figure 1

1. Location of the model and serial numbers

Model No. _____

Serial No. _____

This manual identifies potential hazards and has safety messages identified by the following words:

- **Danger** signals an extreme hazard that **will** cause serious injury or death if you do not follow the recommended precautions.
- **Warning** signals a hazard that **may** cause serious injury or death if you do not follow the recommended precautions.
- **Caution** signals a hazard that may cause minor or moderate injury if you do not follow the recommended precautions.

This manual uses two other words to highlight information. **Important** calls attention to special mechanical information and **Note** emphasizes general information worthy of special attention.

Contents

Introduction.....	2
Safety	4
Safe Operating Practices	4
Toro Mower Safety	5
Slope Chart	7
Safety and Instructional Decals	8
Product Overview	10
Controls	11
Specifications	12
Operation.....	12
Adding Fuel	12
Checking the Engine Oil Level.....	13
Think Safety First.....	13

Operating the Parking Brake	13	Mower Deck Maintenance	45
Starting and Stopping the Engine	14	Servicing the Cutting Blades	45
Operating the Mower Blade Control		Correcting the Mower Quality of Cut	47
(PTO)	15	Frame Set Up	48
The Safety Interlock System.....	15	Checking the Mower Deck Front-to-Rear	
Driving Forward or Backward.....	16	Pitch.....	49
Stopping the Machine.....	16	Changing the Mower Deck Front-to-Rear	
Pushing the Machine by Hand.....	17	Pitch.....	50
Transporting Machines.....	17	Checking the Mower Deck Side-to-Side	
Side Discharging or Mulching the Grass	17	Height.....	50
Adjusting the Height-of-Cut	18	Changing the Mower Deck Side-to-Side	
Adjusting the Anti-Scalp Rollers	18	Height.....	51
Adjusting the Flow Baffle	19	Matching Height of Cut	51
Positioning the Flow Baffle.....	20	Replacing the Grass Deflector.....	52
Using the Mid-Size Weight.....	21	Cleaning.....	53
Maintenance.....	23	Cleaning Under the Mower	53
Recommended Maintenance Schedule(s)	23	Waste Disposal.....	53
Lubrication.....	24	Storage.....	53
How to Grease	24	Cleaning and Storage	53
Lubricating the Bearings	24	Troubleshooting.....	55
Greasing the PTO Drive Belt Idler and Mower		Schematics	57
Deck Belt Idler	24		
Engine Maintenance.....	25		
Servicing the Air Cleaner	25		
Servicing the Engine Oil.....	26		
Servicing the Spark Plugs.....	27		
Fuel System Maintenance	29		
Draining the Fuel Tank.....	29		
Servicing the Fuel Filter.....	29		
Electrical System Maintenance.....	30		
Servicing the Battery.....	30		
Servicing the Fuses.....	32		
Drive System Maintenance	33		
Adjusting the Tracking	33		
Checking the Tire Pressure	33		
Replacing the Caster Wheel Fork			
Bushings	34		
Servicing the Caster Wheel and Bearings	34		
Adjusting the Electric Clutch	35		
Cooling System Maintenance.....	36		
Cleaning the Air Intake Screen	36		
Brake Maintenance	36		
Servicing the Brake.....	36		
Belt Maintenance.....	37		
Replacing the Mower Belt	37		
Replacing the PTO Drive Belt.....	38		
Adjusting the PTO Drive Belt Idler Spring			
Anchor.....	39		
Replacing the Pump Drive Belt	39		
Controls System Maintenance.....	40		
Adjusting the Motion Control Handle			
Positions	40		
Hydraulic System Maintenance	42		
Servicing the Hydraulic System	42		

Safety

Note: The addition of attachments made by other manufacturers that do not meet American National Standards Institute certification will cause noncompliance of this machine.

Improper use or maintenance by the operator or owner can result in injury. To reduce the potential for injury, comply with these safety instructions and always pay attention to the safety alert symbol **▲**, which means CAUTION, WARNING, or DANGER-“personal safety instruction.” Failure to comply with the instruction may result in personal injury or death.

Safe Operating Practices

The following instructions are from ANSI standard B71.4-2004.

Training

- Read the Operator’s Manual and other training material. If the operator(s) or mechanic(s) can not read English it is the owner’s responsibility to explain this material to them.
- Become familiar with the safe operation of the equipment, operator controls, and safety signs.
- All operators and mechanics should be trained. The owner is responsible for training the users.
- Never let children or untrained people operate or service the equipment. Local regulations may restrict the age of the operator.
- The owner/user can prevent and is responsible for accidents or injuries occurring to himself or herself, other people or property.

Preparation

- Evaluate the terrain to determine what accessories and attachments are needed to properly and safely perform the job. Only use accessories and attachments approved by the manufacturer.
- Wear appropriate clothing including hard hat, safety glasses and hearing protection. Long hair, loose clothing or jewelry may get tangled in moving parts.
- Inspect the area where the equipment is to be used and remove all objects such as rocks, toys and wire which can be thrown by the machine.
- Use extra care when handling gasoline and other fuels. They are flammable and vapors are explosive.
 - Use only an approved container

- Never remove gas cap or add fuel with engine running. Allow engine to cool before refueling. Do not smoke.
- Never refuel or drain the machine indoors.
- Check that operator’s presence controls, safety switches and shields are attached and functioning properly. Do not operate unless they are functioning properly.

Operation

- Never run an engine in an enclosed area.
- Only operate in good light, keeping away from holes and hidden hazards.
- Be sure all drives are in neutral and parking brake is engaged before starting engine. Only start engine from the operator’s position.
- Be sure of your footing while using this machine, especially when backing up. Walk, don’t run. Never operate on wet grass. Reduced footing could cause slipping.
- Slow down and use extra care on hillsides. Be sure to travel side to side on hillsides. Turf conditions can affect the machine’s stability. Use caution while operating near drop-offs.
- Slow down and use caution when making turns and when changing directions on slopes.
- Never raise deck with the blades running.
- Never operate with the PTO shield, or other guards not securely in place. Be sure all interlocks are attached, adjusted properly, and functioning properly.
- Never operate with the discharge deflector raised, removed or altered, unless using a grass catcher.
- Do not change the engine governor setting or overspeed the engine.
- Stop on level ground, disengage drives, engage parking brake (if provided), shut off engine before leaving the operator’s position for any reason including emptying the catchers or unclogging the chute.
- Stop equipment and inspect blades after striking objects or if an abnormal vibration occurs. Make necessary repairs before resuming operations.
- Keep hands and feet away from the cutting unit.
- Look behind and down before backing up to be sure of a clear path.
- Keep pets and bystanders away.
- Slow down and use caution when making turns and crossing roads and sidewalks. Stop blades if not mowing.

- Be aware of the mower discharge direction and do not point it at anyone.
- Do not operate the mower under the influence of alcohol or drugs.
- Use care when loading or unloading the machine into or from a trailer or truck.
- Use care when approaching blind corners, shrubs, trees, or other objects that may obscure vision.

Maintenance and storage

- Disengage drives, set parking brake, stop engine and remove key or disconnect spark plug wire. Wait for all movement to stop before adjusting, cleaning or repairing.
- Clean grass and debris from cutting unit, drives, mufflers, and engine to help prevent fires. Clean up oil or fuel spillage.
- Let engine cool before storing and do not store near flame.
- Shut off fuel while storing or transporting. Do not store fuel near flames or drain indoors.
- Park machine on level ground. Set parking brake. Never allow untrained personnel to service machine.
- Use jack stands to support components when required.
- Carefully release pressure from components with stored energy.
- Disconnect the battery or remove spark plug wire before making any repairs. Disconnect the negative terminal first and the positive last. Reconnect the positive first and negative last.
- Use care when checking blades. Wrap the blade(s) or wear gloves, and use caution when servicing them. Only replace blades. Never straighten or weld them.
- Keep hands and feet away from moving parts. If possible, do not make adjustments with the engine running.
- Keep all parts in good working condition and all hardware tightened. Replace all worn or damaged decals.

Toro Mower Safety

The following list contains safety information specific to Toro products and other safety information you must know.

This product is capable of amputating hands and feet and throwing objects. Always follow all safety instructions to avoid serious injury or death.

This product is designed for cutting and recycling grass or, when equipped with a grass bagger, for catching cut grass. Any use for purposes other than these could prove dangerous to user and bystanders.

General Operation

- Be sure the area is clear of other people before mowing. Stop the machine if anyone enters the area.
- Do not touch equipment or attachment parts which may be hot from operation. Allow to cool before attempting to maintain, adjust or service.
- Use only Toro approved attachments. Warranty may be voided if used with unapproved attachments.
- Check carefully for overhead clearances (i.e. branches, doorways, electrical wires) before operating under any objects and do not contact them.

Slope Operation

All slopes and ramps require extra caution. If you feel uneasy on a slope, do not mow it.

- Remove obstacles such as rocks, tree limbs, etc. from the mowing area.
- Watch for holes, ruts or bumps. Tall grass can hide obstacles.
- Use caution near drop-offs, ditches, or embankments. The machine could suddenly turn over if a wheel goes over the edge of a cliff or ditch, or if an edge caves in.
- Use extra care with grass catchers or other attachments. These can change the stability of the machine.
- Keep all movement on slopes slow and gradual. Do not make sudden changes in speed or direction.
- Mow slopes side to side.
- Do not mow slopes greater than 15 degrees.

Service

- Never store the machine or fuel container inside where there is an open flame, such as near a water heater or furnace.
- Keep nuts and bolts tight, especially the blade attachment bolts. Keep equipment in good condition.
- Never tamper with safety devices. Check safety systems for proper operation before each use.

- Use only genuine replacement parts to ensure that original standards are maintained.
- Check brake operation frequently. Adjust and service as required.

Slope Chart

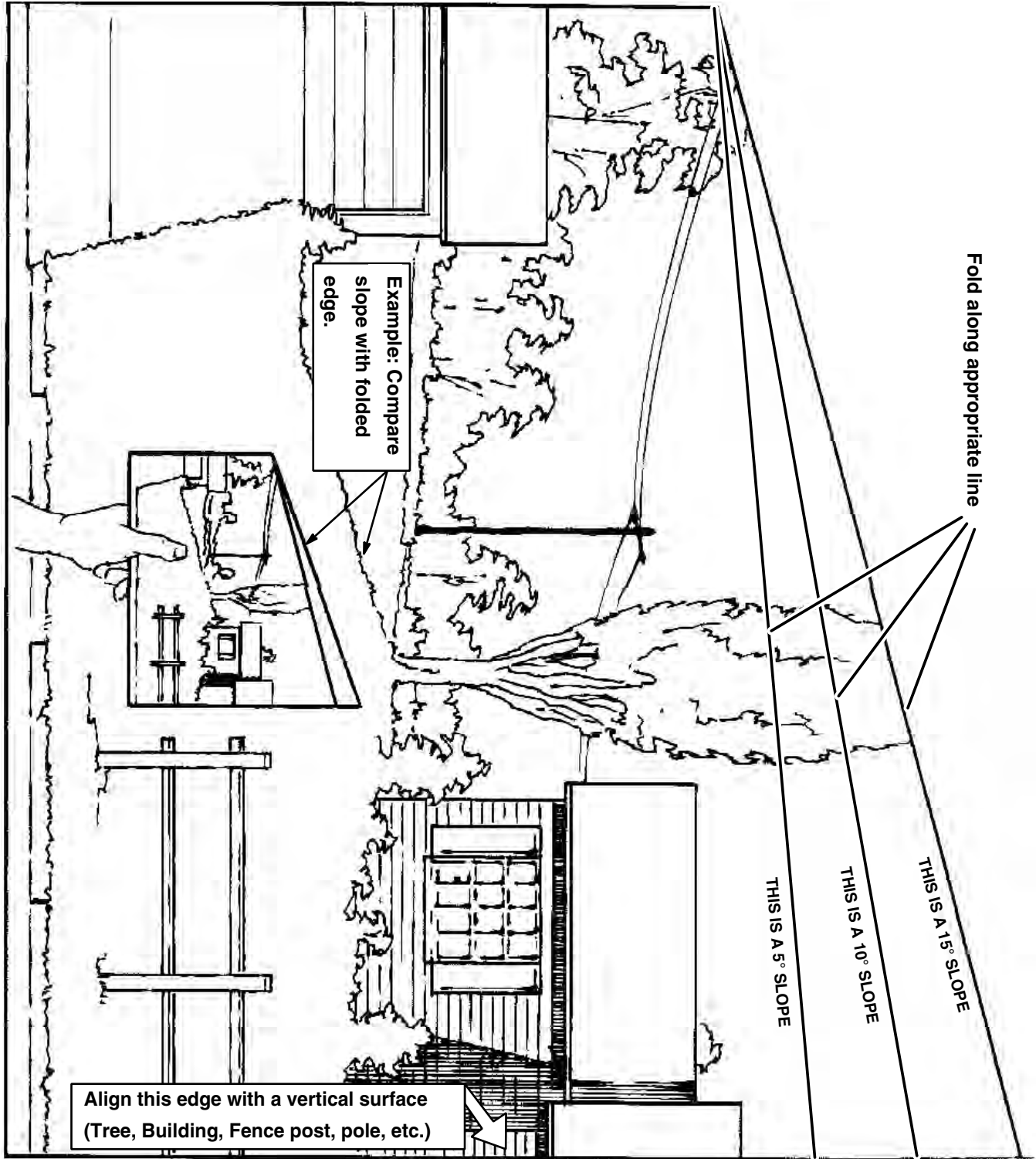

Safety and Instructional Decals



Safety decals and instructions are easily visible to the operator and are located near any area of potential danger. Replace any decal that is damaged or lost.



1-523552

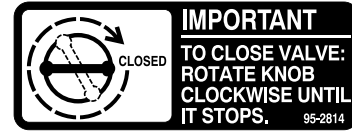

95-2814



98-0776



43-8480



98-5954



66-1340



68-8340



Battery Symbols

Some or all of these symbols are on your battery

1. Explosion hazard
2. No fire, open flame, or smoking.
3. Caustic liquid/chemical burn hazard
4. Wear eye protection
5. Read the *Operator's Manual*.
6. Keep bystanders a safe distance from the battery.
7. Wear eye protection; explosive gases can cause blindness and other injuries
8. Battery acid can cause blindness or severe burns.
9. Flush eyes immediately with water and get medical help fast.
10. Contains lead; do not discard.

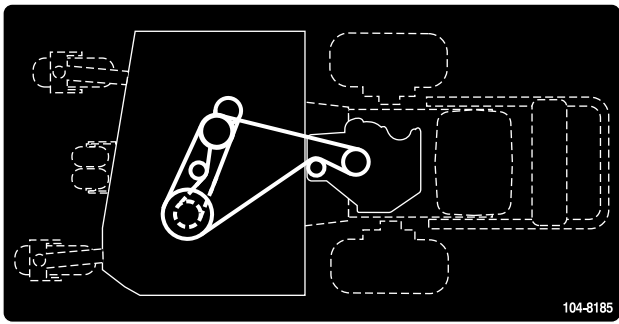

104-8185

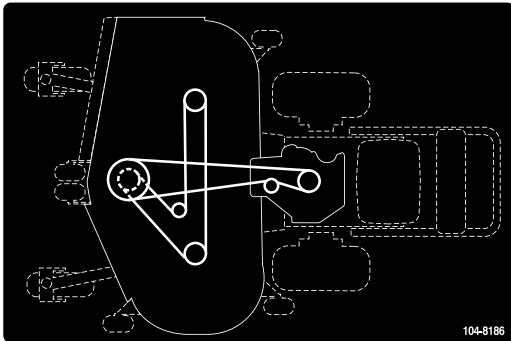

104-8186



104-8569

ANTI-SCALP ROLLER ADJUSTMENT

FOR MAXIMUM DECK FLOTATION, PLACE ROLLERS IN POSITIONS SHOWN.

TURN ENGINE OFF BEFORE MAKING ROLLER ADJUSTMENTS.

- ————— 1.5"/38mm
- ————— 2.0"/51mm
- ————— 2.5"/63mm
- ————— 3.0"/76mm

105-7798

HEIGHT OF CUT PINS ADJUSTMENT

- POSITION ALL PINS IN SAME HEIGHT OF CUT HOLE
- TURN ENGINE OFF BEFORE ADJUSTING DECK CUTTING HEIGHT
- NOTE: HEIGHT IS BASED ON USING ONE FRONT SPACER AND ONE REAR SPACER ON ADJUSTMENT PINS
- ADD ONE ADDITIONAL SPACER TO INCREASE CUTTING HEIGHT 1/4 INCH.
- NOTE: REFER TO OPERATOR'S MANUAL FOR ADDITIONAL HEIGHT OF CUT ADJUSTMENT.

106-0635



106-0699

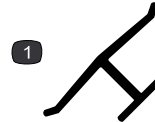

Manufacturer's Mark

1. Indicates the blade is identified as a part from the original machine manufacturer.

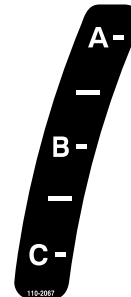

110-2067

ADJUSTABLE BAFFLE
BAFLE AJUSTABLE

A -	• Short, light grass • Dry conditions • Maximum dispersion			• Césped corto y ligero • Condiciones secas • Maxima dispersion
B -	• Bagging setting			• Posicion para usar con bolsa
C -	• Tall, dense grass • Wet conditions • Maximum ground speed			• Césped alto y denso • Condiciones mojadas • Maxima velocidad

110-2068

1. Read the *Operator's Manual*.



112-8720



114-3423

- | | | |
|--------------------------------|-----------|----------|
| 1. Fast | 3. Engine | 5. Choke |
| 2. Continuous variable setting | 4. Slow | |



114-3424

- | | | |
|---------------------|------------|---------------------------------------|
| 1. Traction control | 3. Slow | 5. Reverse |
| 2. Fast | 4. Neutral | 6. Disengage the PTO (Power Take Off) |

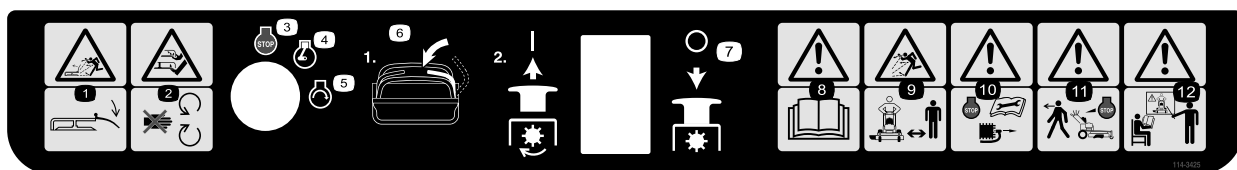

114-3425

- | | | | |
|-------------------------------------------------------------------------------|------------------------------------------------------------------------------------------------------------------------------|---------------------------------------------------------------------------|--------------------------------------------------------------------------------------------------------------|
| 1. Thrown object hazard—keep deflector in place. | 4. Engine—run | 7. Push in on the PTO (Power Take Off) to disengage the blades. | 10. Warning—stop the engine and remove the spark plug wire before performing any maintenance on the machine. |
| 2. Cutting, dismemberment hazard of hand or foot—stay away from moving parts. | 5. Engine—start | 8. Warning—read the <i>Operator's Manual</i> . | 11. Warning—stop the engine before leaving the machine. |
| 3. Engine—stop | 6. Move the motion control lever to the neutral position, then pull out on PTO (Power Take Off) switch to engage the blades. | 9. Thrown object hazard—keep bystanders a safe distance from the machine. | 12. Warning—receive training before operating the machine |

Product Overview

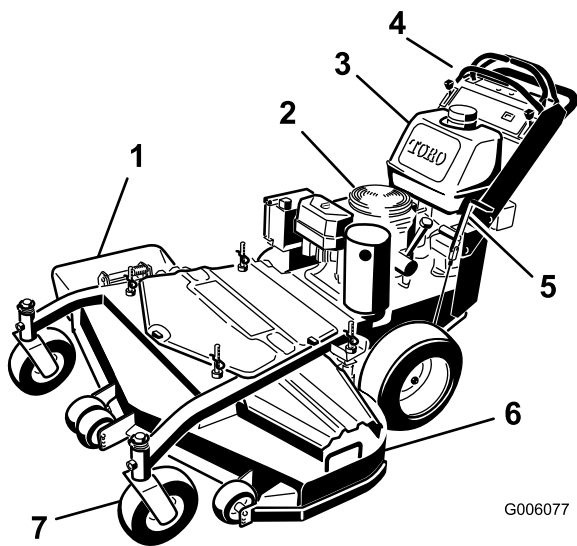

G006077

Figure 2

- | | |
|-------------------------|-----------------------|
| 1. Side discharge chute | 5. Parking brake |
| 2. Engine | 6. Mower deck |
| 3. Gas tank | 7. Front caster wheel |
| 4. Controls | |

Controls

Become familiar with all the controls (Figure 3) before you start the engine and operate the machine.

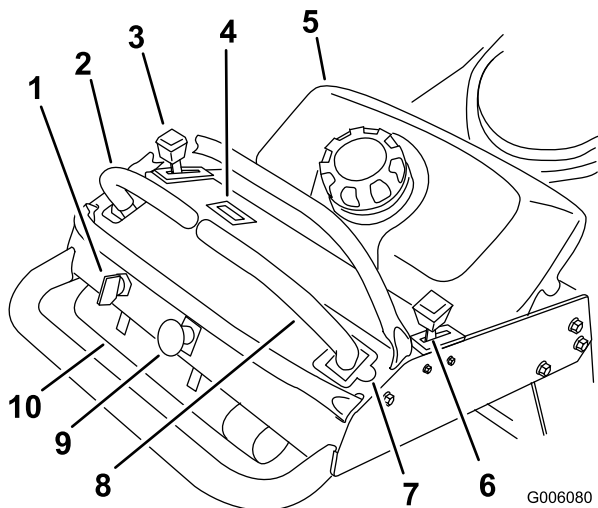

G006080

Figure 3

- | | |
|------------------------------|---------------------------------------------------------|
| 1. Ignition switch | 6. Choke |
| 2. Left motion control lever | 7. Neutral lock position for right motion control lever |
| 3. Throttle control | 8. Right motion control lever |
| 4. Hour meter | 9. blade control switch (PTO) |
| 5. Fuel tank | 10. Operator manual tube |

Throttle Control

The throttle control has two positions: **Fast** and **Slow**.

Choke

Use the choke to start a cold engine.

Blade Control Switch (PTO)

The blade control switch (PTO) is used to engage the electric clutch to drive the mower blades with the right side motion control lever in the center, un-locked position. Pull the switch up to engage the blades and release. To disengage the blades, push the blade control switch (PTO) down or move or release the right side motion control lever into the neutral lock position.

Ignition Switch

This switch is used to start the mower engine and has three positions: **Start**, **Run** and **Off**.

Motion Control Levers

The motion control levers are used to drive the machine forward, reverse, and turn either direction.

Neutral Lock Position

The neutral lock position is used with the safety interlock system to engage and disengage the mower blades and to determine neutral position.

Fuel Shut-off Valve

Close the fuel shut-off valve (under the fuel tank) when transporting or storing the mower.

Hour Meter

Shows the total hours the machine has been operated. This operates only when the mower blades are operating.

The hour meter will flash 3 hours before and after a service interval. The service intervals are set for the first 8 hours, every 100 hours there after, and every 400 hours.

Note: Make sure maintenance is done at all recommended intervals shown in the Recommended Maintenance Schedule.

Attachments/Accessories

A selection of Toro approved attachments and accessories are available for use with the machine to enhance and expand its capabilities. Contact your

Authorized Service Dealer or Distributor or go to www.Toro.com for a list of all approved attachments and accessories.

Specifications

Note: Specifications and design are subject to change without notice.

36 inch mowers:

Width with deflector down	51–1/8 inches (130 cm)
Length	78–1/2 inches (199 cm)
Height	46 inches (117 cm)
Weight	667 lb (303 kg)

40 inch mowers:

Width with deflector down	55–1/2 inches (141 cm)
Length	75–3/8 inches (192 cm)
Height	46 inches (117 cm)
Weight	667 lb (303 kg)

48 inch mowers:

Width with deflector down	63–1/2 inches (161 cm)
Length	77–3/4 inches (198 cm)
Height	46 inches (117 cm)
Weight	682 lb (309 kg)

52 inch mowers:

Width with deflector down	67–5/8 inches (171.7 cm)
Length	77–3/4 inches (198 cm)
Height	46 inches (117 cm)
Weight	721 lb (327 kg)

Operation

Adding Fuel

Use **Unleaded** Regular Gasoline suitable for automotive use (85 pump octane minimum). Leaded regular gasoline may be used if unleaded regular is not available.

Important: Never use methanol, gasoline containing methanol, or gasohol containing more than 10% ethanol because the fuel system could be damaged. Do not mix oil with gasoline.



In certain conditions, gasoline is extremely flammable and highly explosive. A fire or explosion from gasoline can burn you and others and can damage property.

- Fill the fuel tank outdoors, in an open area, when the engine is cold. Wipe up any gasoline that spills.
- Never fill the fuel tank inside an enclosed trailer.
- Do not fill the fuel tank completely full. Add gasoline to the fuel tank until the level is 1/4 to 1/2 inch (6 to 13 mm) below the bottom of the filler neck. This empty space in the tank allows gasoline to expand.
- Never smoke when handling gasoline, and stay away from an open flame or where gasoline fumes may be ignited by a spark.
- Store gasoline in an approved container and keep it out of the reach of children. Never buy more than a 30-day supply of gasoline.
- Do not operate without entire exhaust system in place and in proper working condition.



In certain conditions during fueling, static electricity can be released causing a spark which can ignite the gasoline vapors. A fire or explosion from gasoline can burn you and others and can damage property.

- Always place gasoline containers on the ground away from your vehicle before filling.
- Do not fill gasoline containers inside a vehicle or on a truck or trailer bed because interior carpets or plastic truck bed liners may insulate the container and slow the loss of any static charge.
- When practical, remove gas-powered equipment from the truck or trailer and refuel the equipment with its wheels on the ground.
- If this is not possible, then refuel such equipment on a truck or trailer from a portable container, rather than from a gasoline dispenser nozzle.
- If a gasoline dispenser nozzle must be used, keep the nozzle in contact with the rim of the fuel tank or container opening at all times until fueling is complete.



Gasoline is harmful or fatal if swallowed. Long-term exposure to vapors can cause serious injury and illness.

- Avoid prolonged breathing of vapors.
- Keep face away from nozzle and gas tank or conditioner opening.
- Keep gas away from eyes and skin.

Using Stabilizer/Conditioner

Use a fuel stabilizer/conditioner in the machine to provide the following benefits:

- Keeps gasoline fresh during storage of 90 days or less. For longer storage it is recommended that the fuel tank be drained.
- Cleans the engine while it runs
- Eliminates gum-like varnish buildup in the fuel system, which causes hard starting

Important: Do not use fuel additives containing methanol or ethanol.

Add the correct amount of gas stabilizer/conditioner to the gas.

Note: A fuel stabilizer/conditioner is most effective when mixed with fresh gasoline. To minimize the chance of varnish deposits in the fuel system, use fuel stabilizer at all times.

Filling the Fuel Tank

1. Shut the engine off and set the parking brake.
2. Clean around fuel tank cap and remove the cap. Add unleaded regular gasoline to fuel tank, until the level is 1/4 to 1/2 inch (6 to 13 mm) below the bottom of the filler neck. This space in the tank allows gasoline to expand. Do not fill the fuel tank completely full.
3. Install fuel tank cap securely. Wipe up any gasoline that may have spilled.

Checking the Engine Oil Level

Before you start the engine and use the machine, check the oil level in the engine crankcase; refer to Checking Oil Level in Engine Maintenance.

Note: Determine the left and right sides of the machine from the normal operating position.

Think Safety First

Carefully read all the safety instructions and decals in the safety section. Knowing this information could help you or any bystanders avoid injury.

The use of protective equipment for eyes, hearing, feet and head is recommended.



This machine produces sound levels in excess of 85 dBA at the operator's ear and can cause hearing loss through extended periods of exposure.

Wear hearing protection when operating this machine.

Operating the Parking Brake

Always set the parking brake when you stop the machine or leave it unattended. Before each use, check the parking brake for proper operation.

If the parking brake does not hold securely, adjust it. Refer to Servicing the Parking Brake.



Children or bystanders may be injured if they move or attempt to operate the machine while it is unattended.

Always remove the ignition key and set the parking brake when leaving the machine unattended, even if just for a few minutes.

Setting the Parking Brake

Pull the parking brake lever rearward (Figure 4).

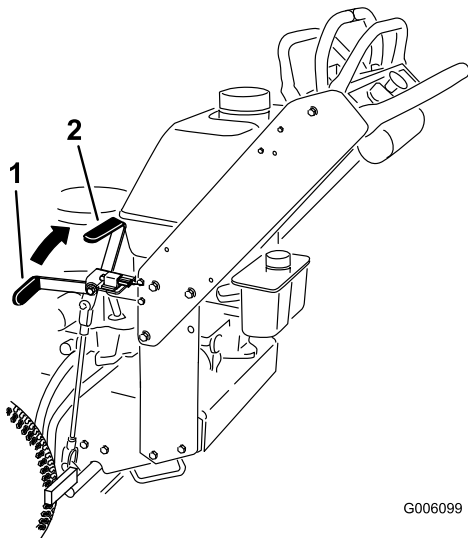

Figure 4

1. Parking brake lever (in the released position)
2. Parking brake lever (in the engaged position)

Releasing the Parking Brake

Push the parking brake lever forward.

Starting and Stopping the Engine

Starting the Engine

1. Connect the wires to the spark plugs.
2. Open the fuel valve.
3. Set the parking brake.
4. Move the throttle control to fast and move the choke lever to the on position before starting a cold engine (Figure 5).

Note: A warm or hot engine may not require choking. To start a warm engine, move throttle control midway between the **fast** and **slow** positions.

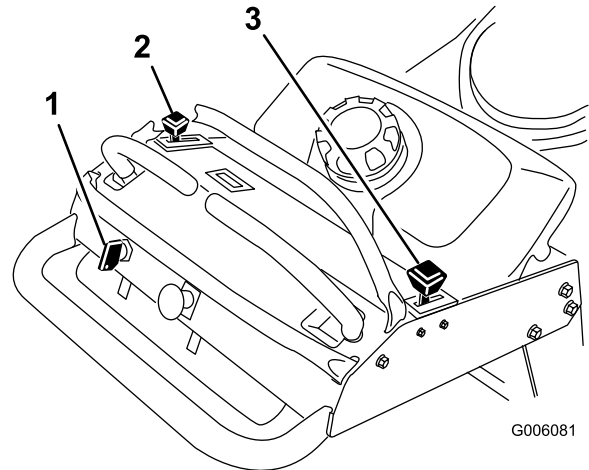

Figure 5

1. Ignition switch
2. Throttle lever
3. Choke

5. Turn the ignition key to the start position to energize the starter. When the engine starts, release the key.

Note: Do not engage the starter for more than 5 seconds at a time. If the engine fails to start, allow for a 15 second cool-down period between attempts. Failure to follow these instructions can burn out the starter motor.

6. When engine starts, move the throttle control between the fast and slow position and move the choke lever to the off position. Allow the engine to warm up and then move the throttle control to the fast position.

Stopping the Engine

1. Move the motion control levers to neutral and move the right side motion control lever into the neutral lock position.
2. Move the throttle lever to slow (Figure 5).
3. If the engine has been working hard or is hot, let the engine idle for 30 to 60 seconds before turning the engine off.
4. To stop the engine, turn the ignition key to off.

Important: Make sure fuel shut off valve is closed before transporting or storing the machine, as fuel leakage may occur. Before storing the machine, pull wire off spark plug(s) to prevent possibility of accidental starting.

Operating the Mower Blade Control (PTO)

The blade control switch (PTO) is used in conjunction with the right side motion control lever to engage and disengage the mower blades.

Engaging the Mower Blades (PTO)

1. To engage the mower blades, move the right side motion control lever to the center, un-locked position (Figure 6).
2. Pull the blade control switch (PTO) up and release it while holding down the right side motion control lever in the center, un-locked position.

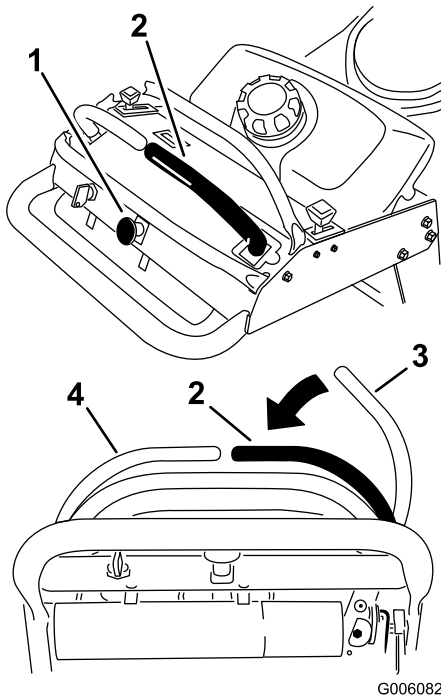

Figure 6

- | | |
|------------------------------------------------------------------------------------|--------------------------------------------------------|
| 1. Blade control switch (PTO) | 3. Right motion control lever in neutral lock position |
| 2. Right side motion control lever pushed down into the center, un-locked position | 4. Left motion control lever |

Disengaging the Mower Blades (PTO)

The following are two options for disengaging the mower blades.

- Push the blade control switch (PTO) down to the off position.
- Move the motion control levers to neutral and move the right side motion control lever into the neutral lock position.

The Safety Interlock System



If safety interlock switches are disconnected or damaged the machine could operate unexpectedly causing personal injury.

- Do not tamper with the interlock switches.
- Check the operation of the interlock switches daily and replace any damaged switches before operating the machine.

Understanding the Safety Interlock System

The safety interlock system is designed to prevent the mower blades from rotating unless:

- The right side motion control lever is moved to the center, un-locked position.
- The blade control switch (PTO) is pulled **on**.

The safety interlock system is designed to stop the mower blades if you move or release the right side motion control lever into the neutral lock position.

Testing the Safety Interlock System

Test the safety interlock system before you use the machine each time.

Note: If the safety system does not operate as described below, have an Authorized Service Dealer repair the safety system immediately.

1. Start the engine; refer to Starting and Stopping the Engine in Operation , page 12.
2. Set the parking brake.
3. Move the right side motion control lever to the center, un-locked position. **The blades should not rotate.**
4. Move the motion control levers forward. **The engine should kill.**
5. Start the engine and release the parking brake.
6. Move the right side motion control lever to the center, un-locked position.
7. Continue holding the right side motion control lever in the center, un-locked position and pull up on the blade control switch (PTO) and release. The clutch should engage and the mower blades begin rotating.
8. Move or release the right side motion control lever into the neutral lock position. **The blades should stop rotating.**

9. Move the right side motion control lever to the center, un-locked position.
10. Continue holding the right side motion control lever in the center, un-locked position and pull up on the blade control switch (PTO) and release. The clutch should engage and the mower blades begin rotating.
11. Push the blade control switch (PTO) down to the off position. **The blades should stop rotating.**
12. With the engine running, pull up the blade control switch (PTO) and release without holding right side motion control lever to the center, un-locked position. **The blades should not rotate.**

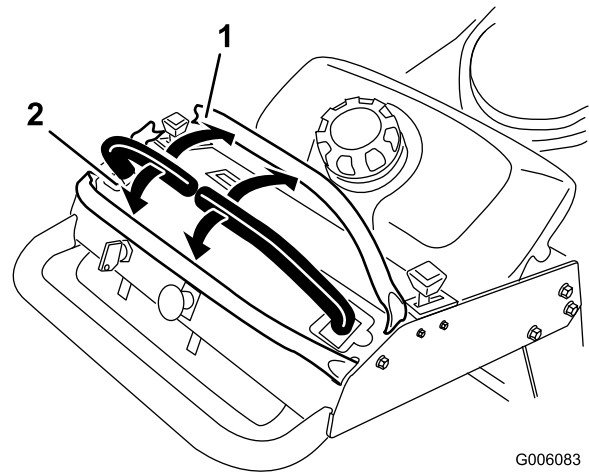

Figure 7

1. Forward

2. Backward

Driving Forward or Backward

The throttle control regulates the engine speed as measured in rpm (revolutions per minute). Place the throttle control in the fast position for best performance. Always operate in the full throttle position when mowing.



Machine can spin very rapidly. Operator may lose control of machine and cause personal injury or damage to machine.

- Use caution when making turns.
- Slow the machine down before making sharp turns.

Driving Forward

1. Release the parking brake; refer to Releasing the Parking Brake in Operation , page 12.
2. Move the right side motion control lever to the center, un-locked position.
3. To go forward, slowly push the motion control levers forward (Figure 7).

Note: The engine will kill if the traction control levers are moved with the parking brake engaged.

To go straight, apply equal pressure to both motion control levers (Figure 7).

To turn, move the motion control lever toward neutral in the direction you want to turn (Figure 7).

The farther you move the traction control levers in either direction, the faster the machine will move in that direction.

To stop, pull the motion control levers back to the neutral position.

Driving Backward

1. Move the right side motion control lever to the center, un-locked position.
2. To go backward, slowly pull the motion control levers rearward (Figure 7).

To go straight, apply equal pressure to both motion control levers (Figure 7).

To turn, release pressure on the motion control lever toward the direction you want to turn (Figure 7).

To stop, push the motion control levers to the neutral position.

Stopping the Machine

To stop the machine, move the motion control levers to neutral, move the right side motion control lever into the neutral lock position, disengage the power take off (PTO), and turn the ignition key to off.

Set the parking brake when you leave the machine; refer to Setting the Parking Brake in Operation , page 12. Remember to remove the key from the ignition switch.



Children or bystanders may be injured if they move or attempt to operate the tractor while it is unattended.

Always remove the ignition key and set the parking brake when leaving the machine unattended, even if just for a few minutes.

Pushing the Machine by Hand

The by-pass valves allow the machine to be pushed by hand without the engine running.

Important: Always push the machine by hand. Never tow the machine because hydraulic damage may occur.

To Push the Machine

1. Disengage the PTO, move the motion control levers to the neutral locked position and set the parking brake.
2. Open the by-pass valve on both pumps by turning them counter clockwise 1 to 2 turns. This allows hydraulic fluid to by-pass the pumps and the wheels to turn (Figure 8).

Note: Rotate the by-pass valves a maximum of 2 turns so the valve does not come out of the body causing fluid to run out.

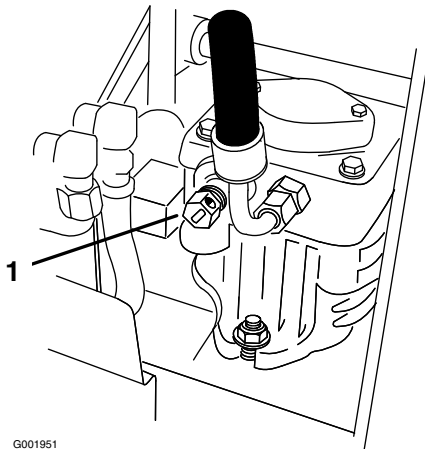

Figure 8

1. Pump by-pass valve

-
3. Release the parking brake.
 4. Push the machine to the desired location.
 5. Set the parking brake.
 6. Close the by-pass valves, but do not overtighten them.

Important: Do not start or operate the machine with the by-pass valves open. Damage to system may occur.

Transporting Machines

Use a heavy-duty trailer or truck to transport the machine. Ensure that the trailer or truck has all

necessary brakes, lighting, and marking as required by law. Please carefully read all the safety instructions. Knowing this information could help you, your family, pets or bystanders avoid injury.

To transport the machine:

1. If using a trailer, connect it to the towing vehicle and connect the safety chains.
2. If applicable, connect the trailer brakes.
3. Load the machine onto the trailer or truck.
4. Stop the engine, remove the key, set the brake, and close the fuel valve.
5. Use the metal tie down loops on the machine to securely fasten the machine to the trailer or truck with straps, chains, cable, or ropes (Figure 9).
6. Fasten the front of the machine to the trailer or truck with straps, chains, cable, or ropes.

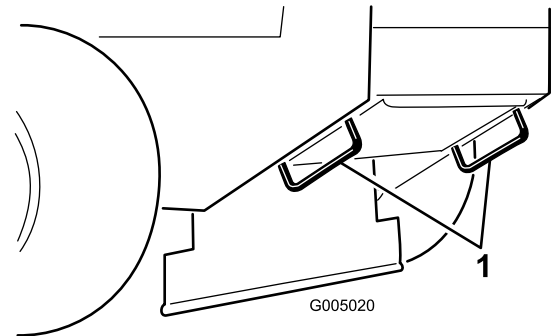

Figure 9

1. Traction unit tie down loop

Side Discharging or Mulching the Grass

This mower has a hinged grass deflector that disperses clippings to the side and down toward the turf.



Without the grass deflector, discharge cover, or complete grass catcher assembly mounted in place, you and others are exposed to blade contact and thrown debris. Contact with rotating mower blade(s) and thrown debris will cause injury or death.

- Never remove the grass deflector from the mower because the grass deflector routes material down toward the turf. If the grass deflector is ever damaged, replace it immediately.
- Never put your hands or feet under the mower.
- Never try to clear discharge area or mower blades unless you release the bail and the power take off (PTO) is off. Rotate the ignition key to Off. Also remove the key and pull the wire(s) off the spark plug(s).

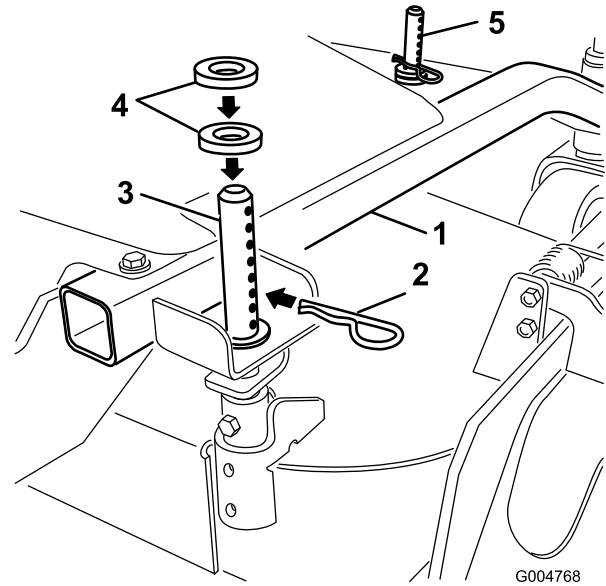

Figure 10

- | | |
|----------------------------|-----------------------------|
| 1. Carrier Frame | 4. Spacers |
| 2. Hairpin Cotter | 5. Front height-of-cut post |
| 3. Back height-of-cut post | |

Adjusting the Height-of-Cut

The height-of-cut can be adjusted from 1 to 4-1/2 inch (25 to 114 mm) in 1/4 inch (6 mm) increments. Adjustment is done by relocating four hairpin cotter pins in different hole location and by adding or removing spacers.

Note: All height-of-cut pins need at least one spacer or damage can occur to bushing if none are used.

Note: All height-of-cut pins can use two spacers maximum.

1. Select hole in height-of-cut post and number of spacers corresponding to the height-of-cut desired (Figure 10).
2. Using the lift handle, raise side of deck and remove hairpin cotter (Figure 10).
3. Add or remove spacers if needed and then align holes and insert hairpin cotter (Figure 10).

Note: Spare height-of-cut spacers may be stored on posts and retained by a hairpin cotter.

Important: All four hairpin cotter pins must be in the same hole location and with the correct number of spacers for a level cut.

Adjusting the Anti-Scalp Rollers

The anti-scalp rollers need to be adjusted in the proper hole location for each height-of-cut position. There needs to be 3/8 inch (10 mm) minimum clearance above the ground.

Note: If the anti-scalp rollers are adjusted too low it can cause excess wear of the rollers.

1. After adjusting height-of-cut, check the anti-scalp rollers so that there is a minimum of 3/8 inch (10 mm) clearance above the ground (Figure 11, Figure 12, Figure 13).
2. If adjustment is needed, remove the bolt, washers and nut (Figure 11, Figure 12, Figure 13).
3. Select a hole position so the anti-scalp rollers are a minimum of 3/8 inch (10 mm) off the ground (Figure 11, Figure 12, Figure 13).
4. Install the bolt and nut (Figure 11, Figure 12, Figure 13).

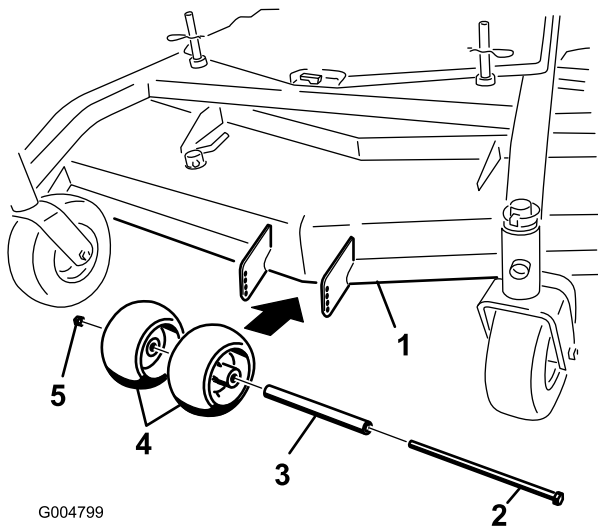

G004799

Figure 11

40 inch, 48 inch, and 52 inch Mower Decks

- | | |
|---------------|-----------------------|
| 1. Mower deck | 4. Anti-Scalp Rollers |
| 2. Bolt | 5. Nut |
| 3. Spacer | |

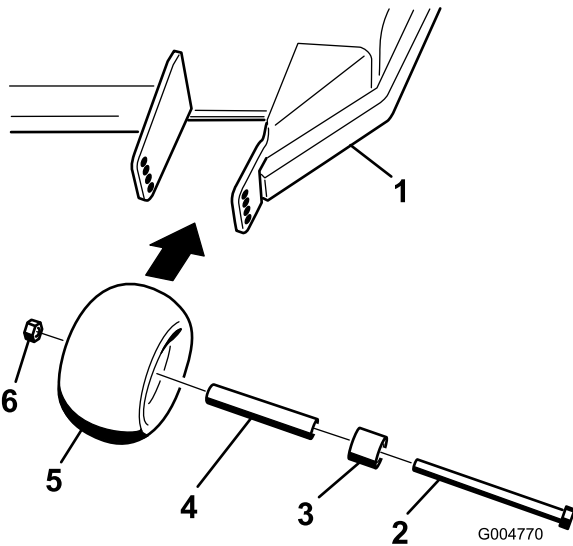

G004770

Figure 12

40 inch, 48 inch, and 52 inch Mower Decks

- | | |
|---------------|-----------------------|
| 1. Mower deck | 4. Bushing |
| 2. Bolt | 5. Anti-Scalp Rollers |
| 3. Spacer | 6. Nut |

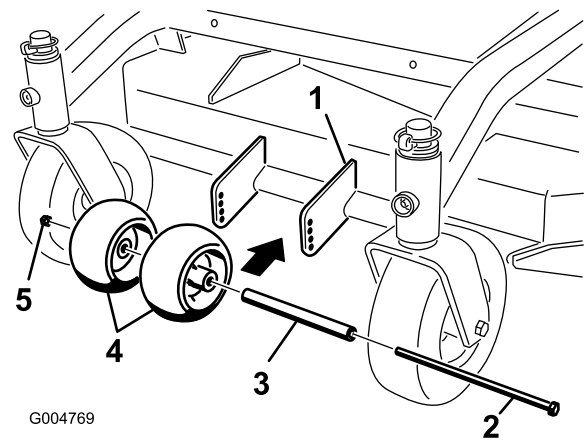

G004769

Figure 13
36 inch Mower Deck

- | | |
|---------------|-----------------------|
| 1. Mower deck | 4. Anti-Scalp Rollers |
| 2. Bolt | 5. Nut |
| 3. Spacer | |

- In certain mowing conditions and terrain, a mismatch of cutting height may be seen. Adjusting the outside anti-scalp rollers to the minimum setting of 3/8 inch (10 mm) will help prevent the mower deck cutting too low on the outside and minimize the mismatch.

Adjusting the Flow Baffle

The mower discharge flow can be adjusted for different types of mowing conditions. Position the cam lock and baffle to give the best quality of cut.

- Disengage the PTO, move the motion control levers to the neutral locked position and set the parking brake.
- Stop the engine, remove the key, and wait for all moving parts to stop before leaving the operating position.
- To adjust the cam lock, swing the lever up to loosen the cam lock (Figure 14).
- Adjust the baffle and cam lock in the slot to the desired discharge flow.
- Swing the lever back over to tighten the baffle and cam lock (Figure 14).
- If the cam does not lock the baffle into place or it is too tight, loosen the lever and then rotate the cam lock. Adjust the cam lock until the desired locking pressure is achieved.

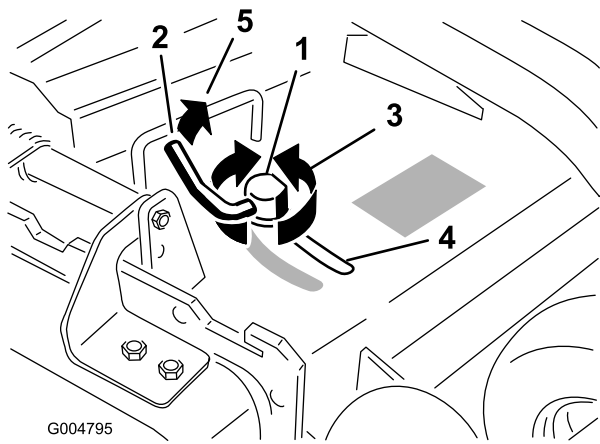

Figure 14

- | | |
|-------------|--------------------------------------------------------|
| 1. Cam lock | 3. Rotate cam to increase or decrease locking pressure |
| 2. Lever | 4. Slot |

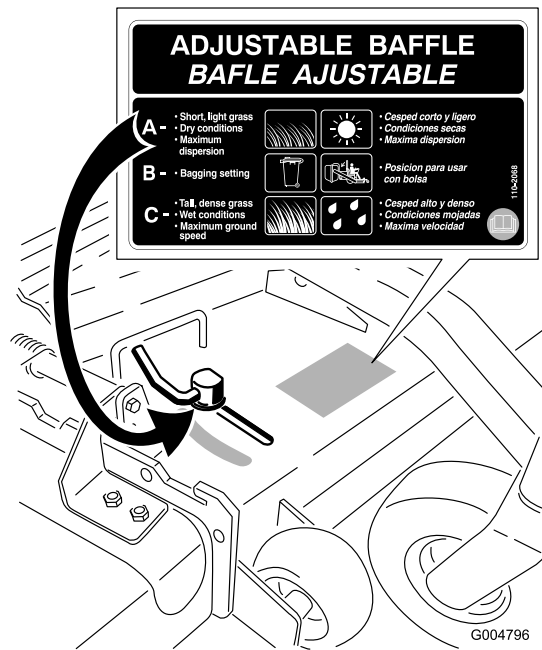

Figure 15

Positioning the Flow Baffle

The following figures are only recommendations for use. Adjustments will vary by grass type, moisture content, and height of grass.

Note: If the engine power draws down and the mower ground speed is the same, open up the baffle.

Position A

This is the full rear position (see Figure 15). The suggested use for this position is as follows.

- Use for short, light grass mowing conditions.
- Use in dry conditions.
- For smaller grass clippings.
- Propels grass clippings farther away from the mower.

Position B

Use this position when bagging (Figure 16).

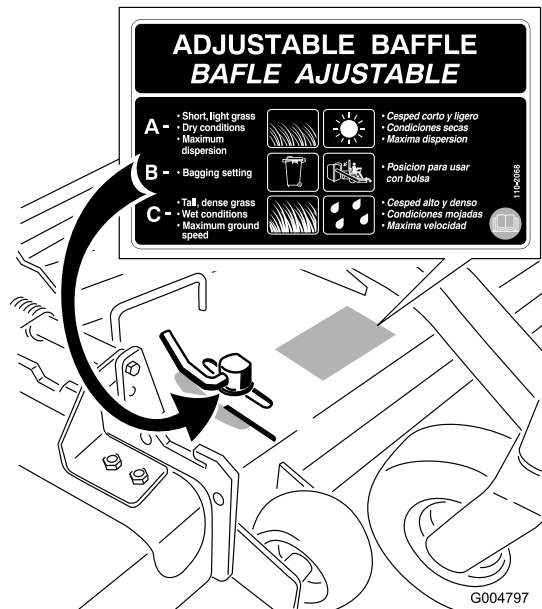

Figure 16

Position C

This is the full open position. The suggested use for this position is as follows (Figure 17).

- Use in tall, dense grass mowing conditions.
- Use in wet conditions.
- Lowers the engine power consumption.

- Allows increased ground speed in heavy conditions.
- This position is similar to the benefits of the Toro SFS mower.

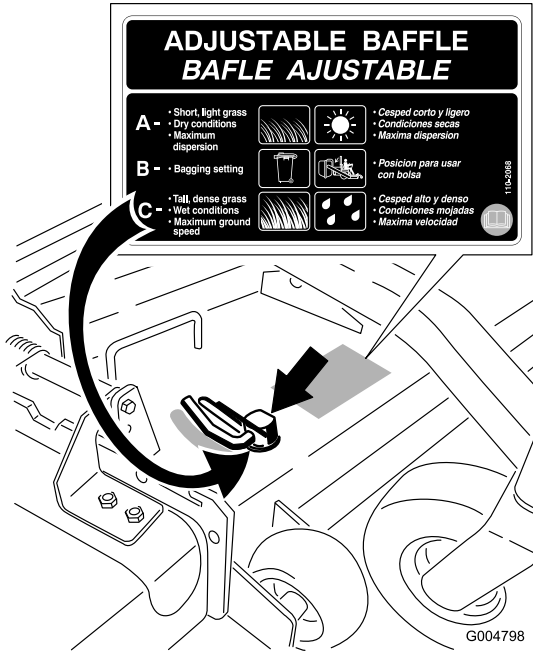

Figure 17

Using the Mid-Size Weight

Weights are installed on certain mowers to improve balance and improve performance. The weights can be moved or removed to create optimized performance under different mowing conditions and for operator preference (Figure 18 or Figure 19).

The following table indicates the position of the weight as installed at the factory.

Mower Deck Size	Number of weights install	Position of the weight
36 inches	1	Front
40 inches	1	Front
48 inches	none	none
52 inches	1	Rear

- Any rear weight must be removed when a Tru-Track® Sulky is installed.
- When a Tru-Track® Sulky is installed front weights are needed. Contact an Authorized Service Dealer for the correct quantity of weights and placement.



The front end of the machine can rapidly rise up when the mower is removed. This could cause serious injury to you or bystanders.

Support the rear of the machine when removing the mower from the carrier frame.

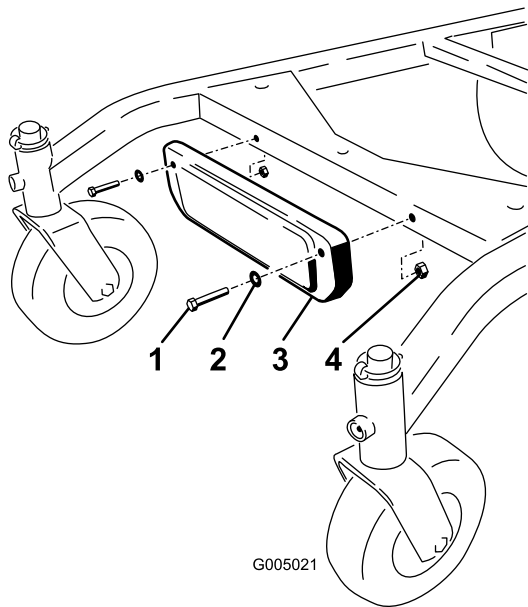

Figure 18
Installing the front weight.

- | | |
|-----------|-----------|
| 1. Bolt | 3. Washer |
| 2. Washer | 4. Nut |

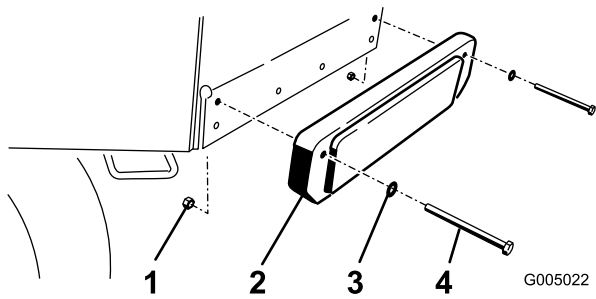

Figure 19
Installing the rear weight.

- | | |
|-----------|-----------|
| 1. Nut | 3. Washer |
| 2. Weight | 4. Bolt |

Maintenance

Note: Determine the left and right sides of the machine from the normal operating position.

Recommended Maintenance Schedule(s)

Maintenance Service Interval	Maintenance Procedure
After the first 8 operating hours	<ul style="list-style-type: none">• Change the engine oil.• Check the hydraulic fluid level.• Change the hydraulic filter.
Before each use or daily	<ul style="list-style-type: none">• Check the safety interlock system.• Grease the front caster pivot bearing.• Check the engine oil level.• Clean the air intake screen.• Check the brakes.• Inspect the blades.• Clean the mower deck.
Every 25 hours	<ul style="list-style-type: none">• Clean foam air cleaner element.• Check the battery electrolyte level.• Check the hydraulic fluid level.
Every 50 hours	<ul style="list-style-type: none">• Grease the side bearings.• Grease the PTO belt idler.• Grease the mower deck belt idler.• Check the paper air cleaner element.• Check the tire pressure.• Check the mower belt.• Check the PTO drive belt.• Check the pump drive belt.
Every 100 hours	<ul style="list-style-type: none">• Change the engine oil.• Check the spark plugs.• Adjust the electric clutch.• Check the hydraulic lines.
Every 200 hours	<ul style="list-style-type: none">• Replace the paper air cleaner element.• Change the oil filter.• Replace the fuel filter.• Change the hydraulic filter.
Every 400 hours	<ul style="list-style-type: none">• Grease the front wheel bearings (more often in dirty or dusty conditions).
Before storage	<ul style="list-style-type: none">• Paint chipped surfaces.• Perform all maintenance procedures listed above before storage.

Important: Refer to your *Engine Operator's Manual* for additional maintenance procedures.



If you leave the key in the ignition switch, someone could accidentally start the engine and seriously injure you or other bystanders.

Remove the key from the ignition and disconnect the spark plug wires from the spark plugs before you do any maintenance. Set the wires aside so that they do not accidentally contact the spark plugs.

Lubrication

Grease with No. 2 general purpose lithium base or molybdenum base grease.

How to Grease

1. Disengage the PTO and set the parking brake.
2. Stop the engine, remove the key, and wait for all moving parts to stop before leaving the operating position.
3. Clean the grease fittings with a rag. Make sure to scrape any paint off the front of the fitting(s).
4. Connect a grease gun to the fitting. Pump grease into the fittings until grease begins to ooze out of the bearings.
5. Wipe up any excess grease.

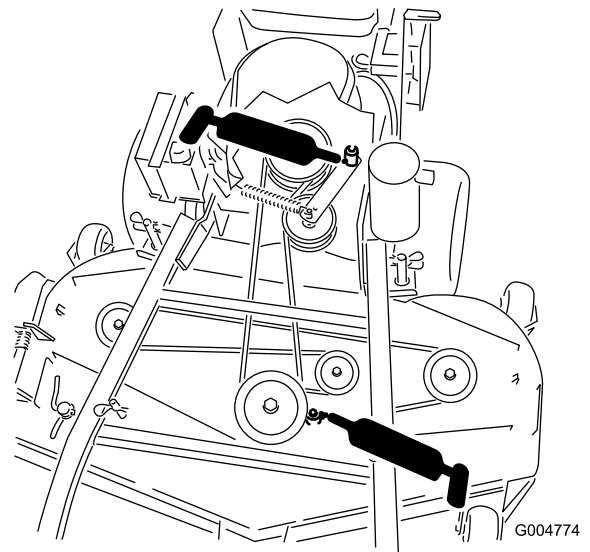

Figure 21
40 inch, 48 inch, and 52 inch Mower Deck shown

Lubricating the Bearings

Lubricate the front caster wheel bearings and front pivots (Figure 20).

Note: Make sure the rear wheel grease caps are removed before lubricating rear wheels.

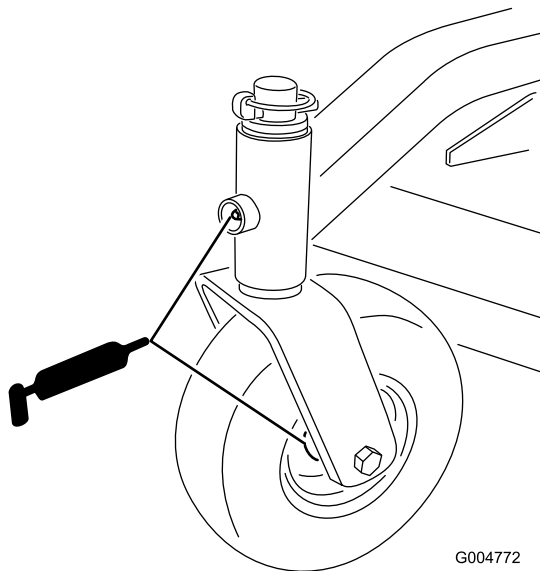

Figure 20

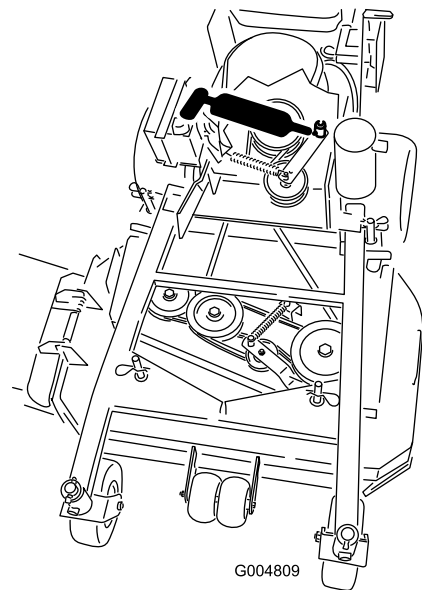

Figure 22
36 inch Mower Deck shown

Greasing the PTO Drive Belt Idler and Mower Deck Belt Idler

Grease the idler pulley pivots (Figure 21 or Figure 22).

Note: You will have to remove the carrier covers to access the grease fitting for the mower deck.

Engine Maintenance

Servicing the Air Cleaner

Service Interval/Specification

Foam element: Clean it after every 25 operating hours.

Paper element: Check it after every 50 operating hours. Replace it after every 200 operating hours or yearly, whichever ever comes first.

Inspect the foam and paper elements and replace them if they are damaged or excessively dirty.

Note: Service the air cleaner more frequently (every few operating hours) if the operating conditions are extremely dusty or sandy.

Important: Do not oil the foam or paper element.

Removing the Foam and Paper Elements

1. Disengage the PTO and set the parking brake.
2. Stop the engine, remove the key, and wait for all moving parts to stop before leaving the operating position.
3. Clean around the air cleaner to prevent dirt from getting into the engine and causing damage (Figure 23).
4. Unscrew the cover knob and remove the air cleaner cover (Figure 23).
5. Remove the 2 wing nuts and remove the air cleaner assembly (Figure 23).
6. Carefully pull the foam element off the paper element (Figure 23).

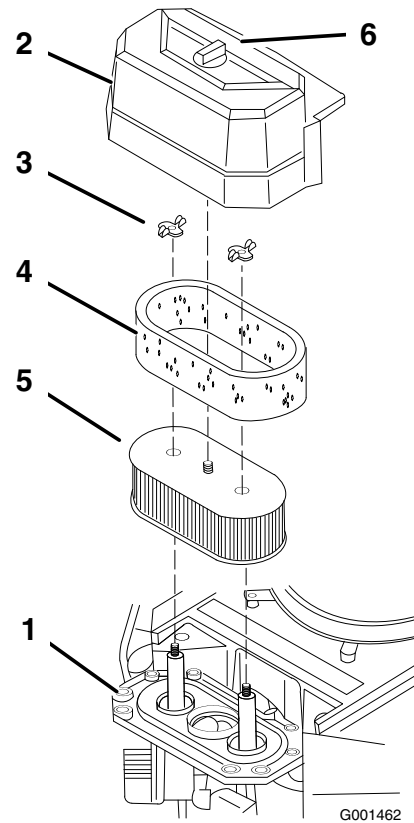

Figure 23

- | | |
|-------------|------------------|
| 1. Engine | 4. Foam element |
| 2. Cover | 5. Paper element |
| 3. Wing nut | 6. Cover knob |

Cleaning the Foam Air Cleaner Element

1. Wash the foam element in liquid soap and warm water. When the element is clean, rinse it thoroughly.
2. Dry the element by squeezing it in a clean cloth.

Important: Replace the foam element if it is torn or worn.

Servicing the Paper Air Cleaner Element

1. Do not clean the paper filter. Replace it after 200 operating hours (Figure 23).
2. Inspect the element for tears, an oily film, or damage to the rubber seal.
3. Replace the paper element if it is damaged.

Installing the Foam and Paper Elements

Important: To prevent engine damage, always operate the engine with the complete foam and paper air cleaner assembly installed.

1. Carefully slide the foam element onto the paper air cleaner element (Figure 23).

- Place the air cleaner assembly onto the air cleaner base and secure it with the 2 wing nuts (Figure 23).
- Place the air cleaner cover into position and tighten the cover knob (Figure 23).

Servicing the Engine Oil

Service Interval/Specification

Check the engine oil level daily.

Change the engine oil as follows:

- After the first 8 operating hours
- After every 100 operating hours

Note: Change the oil more frequently when the operating conditions are extremely dusty or sandy.

Oil Type: Detergent oil (API service SF, SG, SH, or SJ)

Crankcase Capacity: 58 ounces (1.7 liter) with the filter removed; 51 ounces (1.5 liter) without the filter removed

Viscosity: Refer to the table (Figure 24).

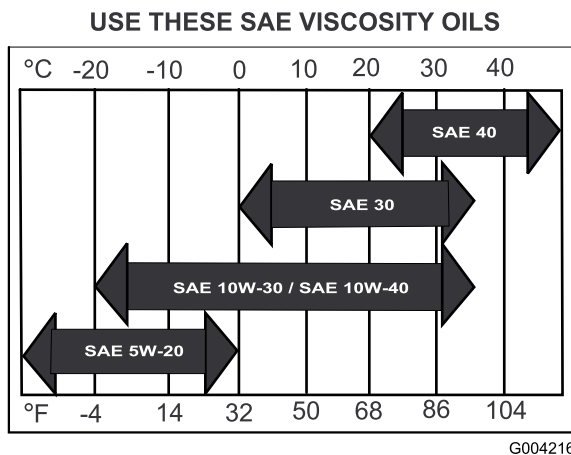

Figure 24

Checking the Engine Oil Level

- Park the machine on a level surface.
- Disengage the PTO and set the parking brake.
- Stop the engine, remove the key, and wait for all moving parts to stop before leaving the operating position.
- Clean around the oil dipstick (Figure 25) so that dirt cannot fall into the filler hole and damage the engine.

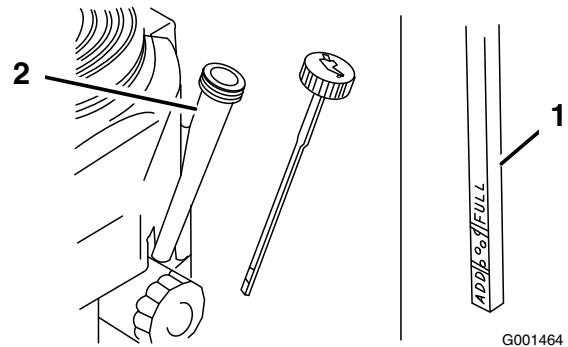

Figure 25

- Oil dipstick
- Filler tube

- Unscrew the oil dipstick and wipe the end clean (Figure 25).
- Slide the oil dipstick fully into the filler tube, but do not thread onto tube (Figure 25).
- Pull the dipstick out and look at the end. If the oil level is low, slowly pour only enough oil into the filler tube to raise the level to the Full mark.

Important: Do not overfill the crankcase with oil and run the engine; engine damage can result.

Changing the Oil

- Start the engine and let it run five minutes. This warms the oil so it drains better.
- Park the machine so that the drain side is slightly lower than the opposite side to assure the oil drains completely.
- Disengage the PTO and set the parking brake.
- Stop the engine, remove the key, and wait for all moving parts to stop before leaving the operating position.
- Slide the drain hose over the oil drain valve.
- Place a pan below the drain hose. Rotate oil drain valve to allow oil to drain (Figure 26).
- When oil has drained completely, close the drain valve.
- Remove the drain hose (Figure 26).

Note: Dispose of the used oil at a recycling center.

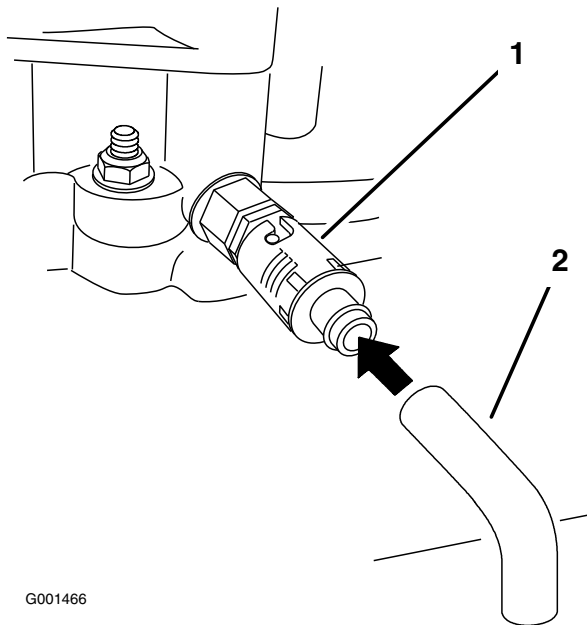

G001466

Figure 26

1. Oil drain valve
2. Oil drain hose

9. Slowly pour approximately 80% of the specified oil into the filler tube (Figure 25).
10. Check the oil level; refer to Checking the Engine Oil Level.
11. Slowly add the additional oil to bring it to the **Full** mark.

Changing the Oil Filter

Replace the oil filter every 200 operating hours or every other oil change.

Note: Change the oil filter more frequently when the operating conditions are extremely dusty or sandy.

1. Drain the oil from the engine; refer to Changing the Engine Oil.
2. Remove the old filter (Figure 27).

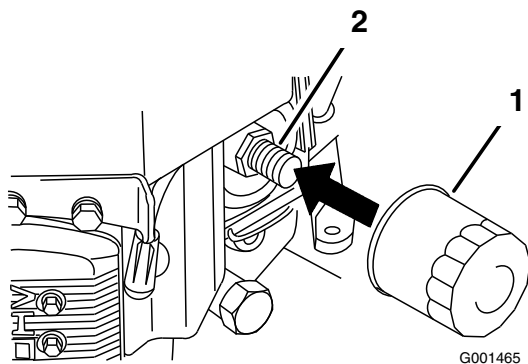

G001465

Figure 27

1. Oil filter
2. Adapter

3. Apply a thin coat of new oil to the rubber gasket on the replacement filter (Figure 27).
4. Install the replacement oil filter to the filter adapter, turn the oil filter clockwise until the rubber gasket contacts the filter adapter, then tighten the filter an additional 3/4 turn (Figure 27).
5. Fill the crankcase with the proper type of new oil; refer to Servicing the Engine Oil.
6. Run the engine for about 3 minutes, stop the engine, and check for oil leaks around the oil filter and drain valve.
7. Check the engine oil level and add oil if needed.
8. Wipe up any spilled oil.

Servicing the Spark Plugs

Check the spark plugs after every 100 operating hours.

Ensure that the air gap between the center and side electrodes is correct before installing the spark plug. Use a spark plug wrench for removing and installing the spark plugs and a gapping tool/feeler gauge to check and adjust the air gap. Install a new spark plugs if necessary.

Type: Champion® RCJ8Y or equivalent Air Gap: 0.030 inch (0.75 mm)

Removing the Spark Plugs

1. Disengage the PTO and set the parking brake.
2. Stop the engine, remove the key, and wait for all moving parts to stop before leaving the operating position.
3. Disconnect the wires from the spark plugs (Figure 28).

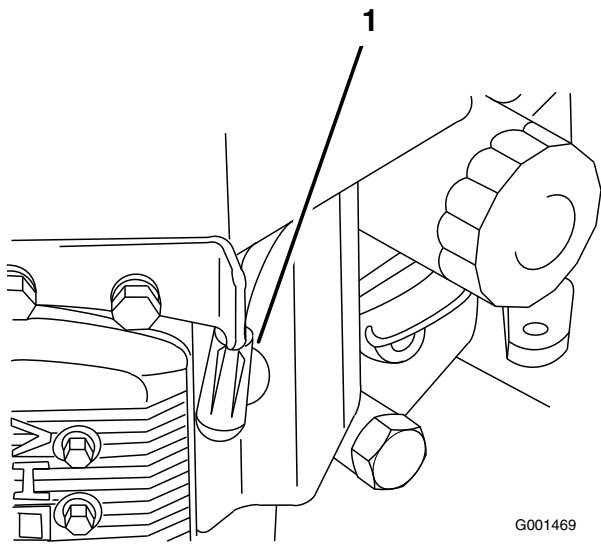

Figure 28

1. Spark-plug wire/spark plug

4. Clean around the spark plugs to prevent dirt from falling into the engine and potentially causing damage.
5. Remove the spark plugs and the metal washers.

Checking the Spark Plugs

1. Look at the center of the spark plugs (Figure 29). If you see light brown or gray on the insulator, the engine is operating properly. A black coating on the insulator usually means that the air cleaner is dirty.
2. If needed, clean the spark plug with a wire brush to remove carbon deposits.

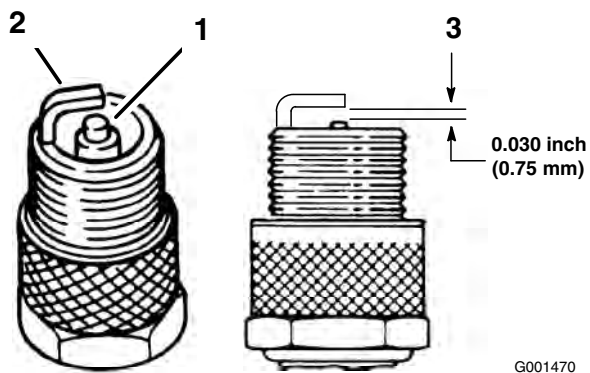

Figure 29

1. Center electrode insulator
2. Side electrode
3. Air gap (not to scale)

Important: Always replace the spark plugs when it has worn electrodes, an oily film on it, or has cracks in the porcelain.

3. Check the gap between the center and side electrodes (Figure 29). Bend the side electrode (Figure 29) if the gap is not correct.

Installing the Spark Plugs

1. Install the spark plugs and the metal washer. Ensure that the air gap is set correctly.
2. Tighten the spark plugs to 16 ft-lb (22 N-m).
3. Connect the wires to the spark plugs (Figure 29).

Fuel System Maintenance

Draining the Fuel Tank



In certain conditions, gasoline is extremely flammable and highly explosive. A fire or explosion from gasoline can burn you and others and can damage property.

- Drain gasoline from the fuel tank when the engine is cold. Do this outdoors in an open area. Wipe up any gasoline that spills.
- Never smoke when draining gasoline, and stay away from an open flame or where a spark may ignite the gasoline fumes.

1. Park the machine on a level surface, to assure fuel tank drains completely. Then disengage the power take off (PTO), set the parking brake, and turn the ignition key to **off**. Remove the key.
2. Close the fuel shut-off valve at the fuel tank (Figure 30).
3. Squeeze the ends of the hose clamp together and slide it up the fuel line away from fuel filter (Figure 30).
4. Pull the fuel line off the fuel filter (Figure 30). Open the fuel shut-off valve and allow the gasoline to drain into a gas can or drain pan.

Note: Now is the best time to install a new fuel filter because the fuel tank is empty. Refer to Replacing the Fuel Filter.

5. Install the fuel line onto the fuel filter. Slide the hose clamp close to the valve to secure the fuel line.
6. Wipe up any spilled fuel.

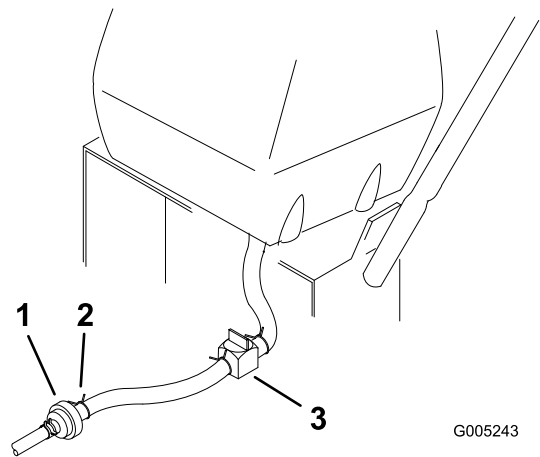

Figure 30

1. Fuel shut-off valve
2. Clamp

Servicing the Fuel Filter

Replace the fuel filter after every 200 operating hours or yearly, whichever occurs first.

Replacing the Fuel Filter

Never install a dirty filter if it is removed from the fuel line.

Note: Note how the fuel filter is installed in order to install the new filter correctly.

Note: Wipe up any spilled fuel.

1. Disengage the PTO and set the parking brake.
2. Stop the engine, remove the key, and wait for all moving parts to stop before leaving the operating position.
3. Close fuel shut-off valve at the fuel tank (Figure 30).
4. Squeeze the ends of the hose clamps together and slide them away from the filter (Figure 31).

Electrical System Maintenance

Servicing the Battery

Check the electrolyte level in the battery every 25 hours. Always keep the battery clean and fully charged. Use a paper towel to clean the battery case. If the battery terminals are corroded, clean them with a solution of four parts water and one part baking soda. Apply a light coating of grease to the battery terminals to prevent corrosion.

Voltage: 12 V

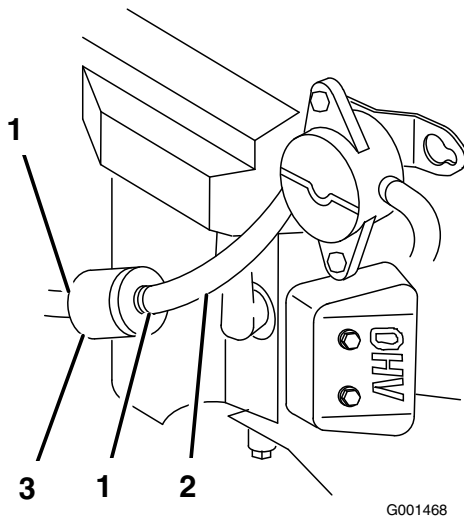

Figure 31

1. Hose clamp
2. Fuel line
3. Filter

5. Remove the filter from the fuel lines.
6. Install a new filter and move the hose clamps close to the filter.
7. Open fuel shut-off valve at fuel tank (Figure 30).
8. Check for fuel leaks and repair if needed.
9. Wipe up any spilled fuel.

Warning

CALIFORNIA

Proposition 65 Warning

Battery posts, terminals, and related accessories contain lead and lead compounds, chemicals known to the State of California to cause cancer and reproductive harm. Wash hands after handling.



Battery electrolyte contains sulfuric acid which is a deadly poison and causes severe burns.

Do not drink electrolyte and avoid contact with skin, eyes or clothing. Wear safety glasses to shield your eyes and rubber gloves to protect your hands.

Removing the Battery



Battery terminals or metal tools could short against metal machine components causing sparks. Sparks can cause the battery gasses to explode, resulting in personal injury.

- When removing or installing the battery, do not allow the battery terminals to touch any metal parts of the machine.
- Do not allow metal tools to short between the battery terminals and metal parts of the machine.



Incorrect battery cable routing could damage the machine and cables causing sparks. Sparks can cause the battery gasses to explode, resulting in personal injury.

- Always Disconnect the negative (black) battery cable before disconnecting the positive (red) cable.
- Always Reconnect the positive (red) battery cable before reconnecting the negative (black) cable.

1. Disengage the PTO and set the parking brake.
2. Stop the engine, remove the key, and wait for all moving parts to stop before leaving the operating position.
3. Lift the black rubber cover on the negative cable. Disconnect the negative battery cable from the negative (-) battery terminal (Figure 32).
4. Slide the red terminal boot off the positive (red) battery terminal. Then remove the positive (red) battery cable (Figure 32).
5. Remove the battery hold down plate (Figure 32) and remove the battery.

Installing the Battery

1. Place the batter onto the machine (Figure 32).
2. Secure the battery with the hold down plate, j-bolts, and locknuts.
3. First, install the positive (red) battery cable to positive (+) battery terminal with a nut, washer and bolt (Figure 32). Slide the rubber cover over the post.
4. Then install the negative battery cable and ground wire to the negative (-) battery terminal with a nut, washer and bolt (Figure 32). Slide the rubber cover over the post.

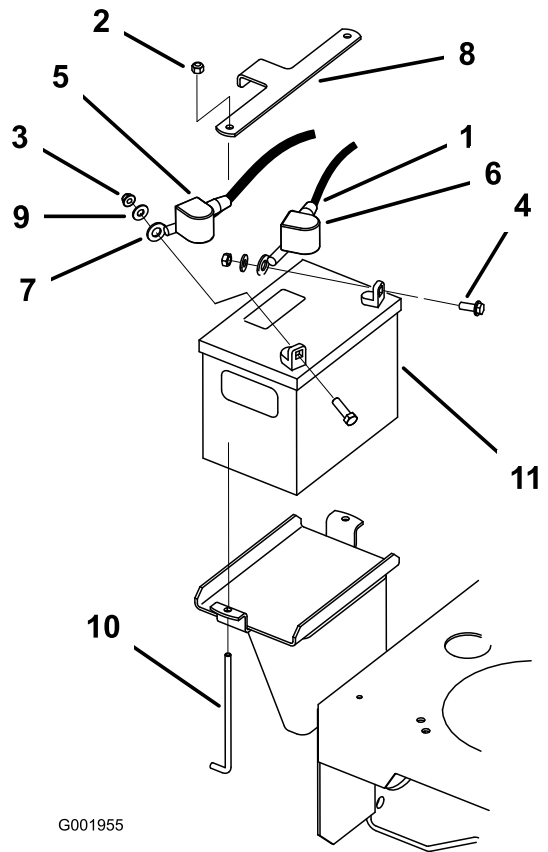

G001955

Figure 32

- | | |
|-------------------------|----------------------------|
| 1. Negative cable | 7. Positive cable |
| 2. Nut (1/4 in.) | 8. Battery hold down plate |
| 3. Nut (5/16 in.) | 9. Washer |
| 4. Bolt | 10. Battery hold down |
| 5. Rubber cover (red) | 11. Battery |
| 6. Rubber cover (black) | |

Checking the Battery Electrolyte Level



Battery electrolyte contains sulfuric acid which is a deadly poison and causes severe burns.

- Do not drink electrolyte and avoid contact with skin, eyes or clothing. Wear safety glasses to shield your eyes and rubber gloves to protect your hands.
- Fill the battery where clean water is always available for flushing the skin.

1. Look at the side of the battery. The electrolyte must be up to the **upper** line (Figure 33). Do not allow the electrolyte to fall below the Lower line (Figure 33).

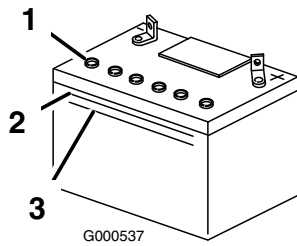

Figure 33

1. Vent caps
2. Upper line
3. Lower line

2. If the electrolyte is low, add the required amount of distilled water; refer to Adding Water to the Battery in Electrical System Maintenance , page 30.

Adding Water to the Battery

The best time to add distilled water to the battery is just before you operate the machine. This lets the water mix thoroughly with the electrolyte solution.

1. Remove the battery from the machine; refer to Removing the Battery in Electrical System Maintenance , page 30.

Important: Never fill the battery with distilled water while the battery is installed in the machine. Electrolyte could be spilled on other parts and cause corrosion.

2. Clean the top of the battery with a paper towel.
3. Remove the vent caps from the battery (Figure 33).
4. Slowly pour distilled water into each battery cell until the electrolyte level is up to the Upper line (Figure 33) on the battery case.

Important: Do not overfill the battery because electrolyte (sulfuric acid) can cause severe corrosion and damage to the chassis.

5. Wait five to ten minutes after filling the battery cells. Add distilled water, if necessary, until the electrolyte level is up to the Upper line (Figure 33) on the battery case.
6. Reinstall the battery vent caps.

Charging the Battery



Charging the battery produces gasses that can explode.

Never smoke near the battery and keep sparks and flames away from battery.

Important: Always keep the battery fully charged (1.265 specific gravity). This is especially important to prevent battery damage when the temperature is below 32°F (0°C).

1. Remove the battery from the chassis; refer to Removing the Battery.
2. Check the electrolyte level; refer to Checking the Electrolyte Level.
3. Make sure the filler caps are installed in battery. Charge battery for 1 hour at 25 to 30 amps or 6 hours at 4 to 6 amps.
4. When the battery is fully charged, unplug the charger from the electrical outlet, then disconnect the charger leads from the battery posts (Figure 34).
5. Install the battery onto the machine and connect the battery cables, refer to Installing the Battery.

Note: Do not run the machine with the battery disconnected, electrical damage may occur.

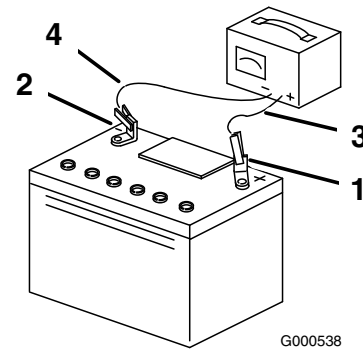

Figure 34

1. Positive Battery Post
2. Negative Battery Post
3. Red (+) Charger Lead
4. Black (-) Charger Lead

Servicing the Fuses

The electrical system is protected by fuses. It requires no maintenance. If a fuse blows, check the component or circuit for a malfunction or short.

1. Remove the cover under the control panel.
2. Pull out on the fuse to remove or replace it (Figure 35).
3. Install the cover under the control panel.

Note: Ensure the correct size fuse is install with the correct wire color as shown in Figure 35.

Drive System Maintenance

Adjusting the Tracking

1. If the machine does not track straight, adjustment is required.
2. Check the rear tire pressure. Refer to Checking the Tire Pressure.
3. Loosen the wing nuts on the right control rod and rotate the turnbuckle in or out to ensure the right side control lever is centered in the neutral lock position. Secure the turnbuckle in position with the wing nuts (Figure 36).
4. Loosen the wing nuts on the left control rod and rotate the turnbuckle in or out to change the tracking. Secure the turnbuckle in position with the wing nuts (Figure 36).
5. Check for proper tracking. Adjust the left control rod if a change is needed.

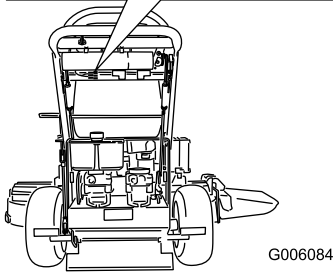
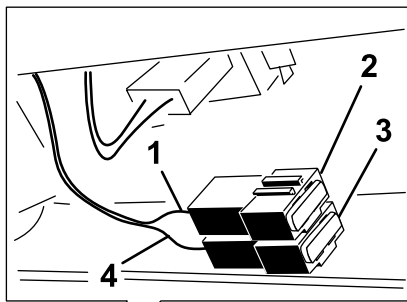

Figure 35

1. Red wire
2. Fuse, 30 amp, blade type
3. Fuse, 25 amp, blade type
4. Violet wire

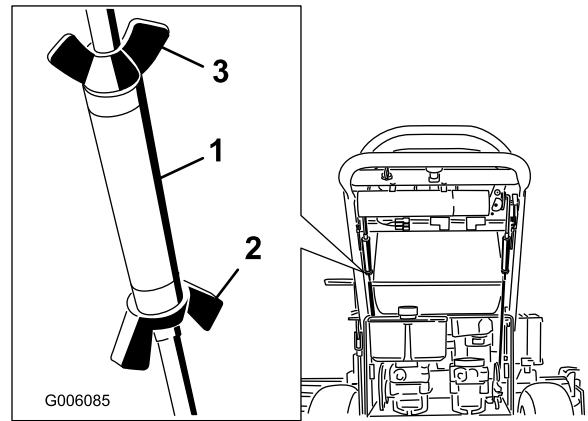

Figure 36

1. Turnbuckle
2. Bottom wing nut
3. Top wing nut (left hand threaded)

Checking the Tire Pressure

Check the pressure at the valve stem after every 50 operating hours or monthly, whichever occurs first (Figure 37).

Maintain the air pressure in the rear tires at 12-14 psi (83-97 kPa). Uneven tire pressure can cause an uneven cut.

Note: The front tires are semi-pneumatic tires and do not require air pressure maintenance.

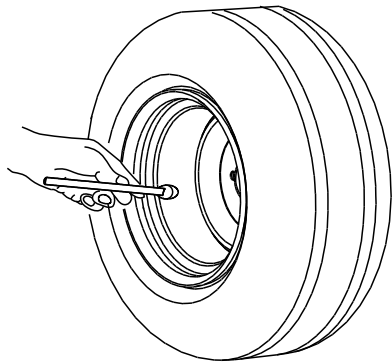

G001055

Figure 37

Replacing the Caster Wheel Fork Bushings

The caster wheel forks are mounted in bushings pressed into the top and bottom of the carrier frame mounting pivot tubes. To check the bushings, move the caster forks back and forth and side-to-side. If a caster fork is loose, the bushings are worn and must be replaced.

1. Raise the cutting unit so the caster wheels are off the floor, then support the front of the mower with jack stands.
2. Remove the locking pin and spacer(s) from the top of the caster wheel fork (Figure 38).

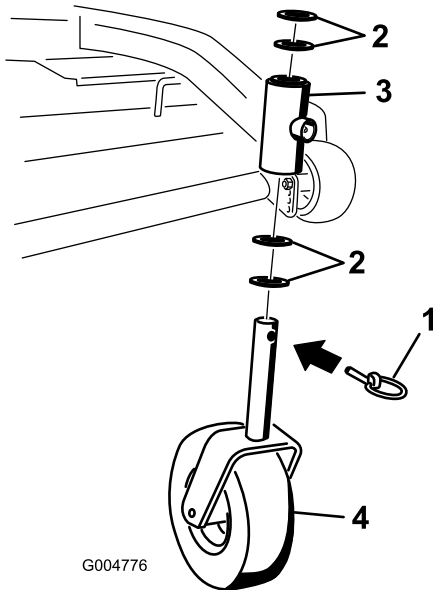

G004776

Figure 38

- | | |
|----------------|-----------------------------|
| 1. Locking Pin | 3. Carrier frame pivot tube |
| 2. Spacers | 4. Caster wheel fork |

3. Pull the caster wheel fork out of the mounting tube, leaving the spacer(s) on the bottom of the fork. Remember the location of the spacers on each fork

to ensure correct installation, and to maintain a level deck.

4. Insert a pin punch into the mounting tube and carefully drive out the bushings (Figure 39). Clean the inside of the mounting tube.

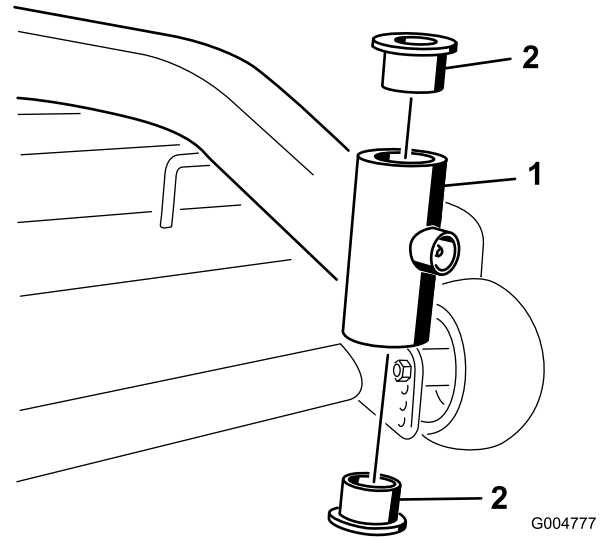

G004777

Figure 39

- | | |
|------------------|------------|
| 1. Mounting Tube | 2. Bushing |
|------------------|------------|

5. Grease the inside and outside of the new bushings. Use a hammer and flat plate to carefully drive the bushings into the pivot tubes.
6. Inspect the caster wheel fork for wear and replace if necessary (Figure 38).
7. Slide the caster wheel fork through the bushings in the mounting tube. Replace the spacer(s) onto the fork and secure with the retaining ring (Figure 38).

Important: The inside diameter of the bushings may collapse slightly when installed. If the caster wheel fork does not slide into the new bushings, ream both bushings to an inside diameter of 1.126 inch (29 mm).

8. Grease the fitting on the carrier frame pivot tubes using No. 2 general purpose lithium base or molybdenum base grease.

Servicing the Caster Wheel and Bearings

The caster wheels rotate on a roller bearing supported by a spanner bushing. If the bearing is kept well lubricated, wear will be minimal. Failure to keep the bearing well lubricated will cause rapid wear. A wobbly caster wheel usually indicates a worn bearing.

1. Remove the locknut and wheel bolt holding the caster wheel to the caster fork (Figure 40).

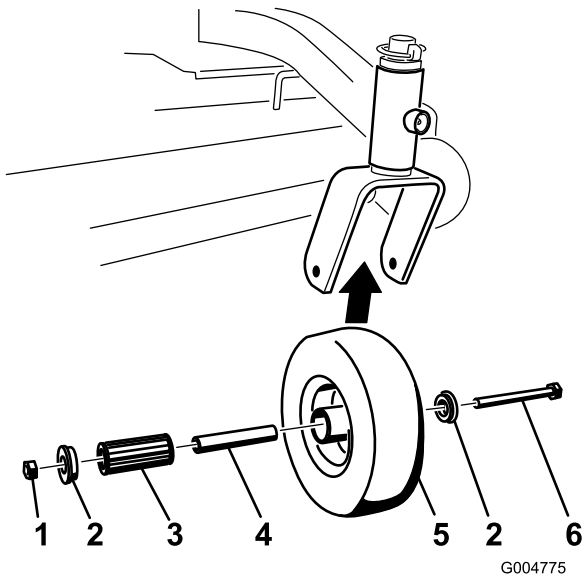

Figure 40

- | | |
|---------------|--------------------|
| 1. Locknut | 4. Spanner Bushing |
| 2. Wheel Bolt | 5. Roller Bearing |
| 3. Bushing | |

3. Repeat this for the remaining slots.
4. Check each slot again and make slight adjustments until the feeler gauge between the rotor and armature with very slight contact between them.

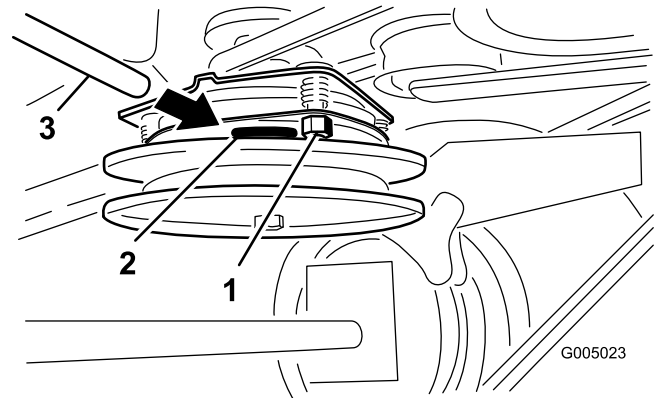

Figure 41

- | | |
|------------------|-----------------|
| 1. Adjusting nut | 3. Feeler gauge |
| 2. Slot | |

2. Remove one bushing, then pull the spanner bushing and roller bearing out of the wheel hub (Figure 40).
3. Remove the other bushing from the wheel hub and clean any grease and dirt from the wheel hub (Figure 40).
4. Inspect the roller bearing, bushings, spanner bushing and inside of the wheel hub for wear. Replace any defective or worn parts (Figure 40).
5. To assemble, place one bushing into the wheel hub. Grease the roller bearing and spanner bushing and slide them into the wheel hub. Place the second bushing into the wheel hub (Figure 40).
6. Install the caster wheel into the caster fork and secure with the wheel bolt and locknut. Tighten the locknut until the spanner bushing bottoms against the inside of the caster forks (Figure 40).
7. Grease the fitting on the caster wheel.

Adjusting the Electric Clutch

The clutch is adjustable to ensure proper engagement and proper braking. Check adjustment after every 100 hours of operation.

1. Insert a 0.015–0.021 inch (0.381–0.533 mm) feeler gauge through one inspection slot in the side of the assembly. Make sure it is between the armature and the rotor friction surfaces.
2. Tighten the lock nuts until there is slight binding on the feeler gauge but it can be moved easily within the air gap (Figure 41).

Cooling System Maintenance

Cleaning the Air Intake Screen

Before each use remove any build-up of grass, dirt or other debris from the cylinder and cylinder head cooling fins, air intake screen on flywheel end, and carburetor-governor levers and linkage. This will help insure adequate cooling and correct engine speed and will reduce the possibility of overheating and mechanical damage to the engine.

Brake Maintenance

Servicing the Brake

Before each use, check brakes on both a level surface and slope.

Always set the parking brake when you stop the machine or leave it unattended. If the parking brake does not hold securely, an adjustment is required.

Checking the Parking Brake

1. Park the machine on a level surface, disengage the PTO.
2. Stop the engine, remove the key, and wait for all moving parts to stop before leaving the operating position.
3. Apply the parking brake. Setting the parking brake should take a reasonable amount of force. If the parking brake does not hold securely, an adjustment is required. Refer to Adjusting the Parking Brake.

Note: When the brake is engaged, the brake handle should be in the 1 o'clock position (Figure 42).

Adjusting the Brakes

If the parking brake does not hold securely, an adjustment is required.

1. Park the machine on a level surface, disengage the PTO, and set the parking brake.
2. Stop the engine, remove the key, and wait for all moving parts to stop before leaving the operating position.
3. Check the brake before you adjust it; refer to Checking the Brakes.
4. Release the parking brake; refer to Releasing the Parking Brake in Operation , page 12.
5. Loosen the top and bottom jam nuts (Figure 42).
6. To adjust the brake, remove the hair pin cotter and clevis pin from the lower brake lever (Figure 42).
7. Rotate the brake rod in the yokes. To tighten the brake, lengthen the rod between the yokes. To loosen the brake, shorten the rod between the yokes (Figure 42).

Note: The brake rod should be threaded into both yokes the same distance.

8. Secure the yoke to lower brake lever with the hair pin cotter and clevis pin (Figure 42).

9. Tighten the top and bottom jam nuts (Figure 42).
10. Check the brake operation again; refer to Checking the Brake.

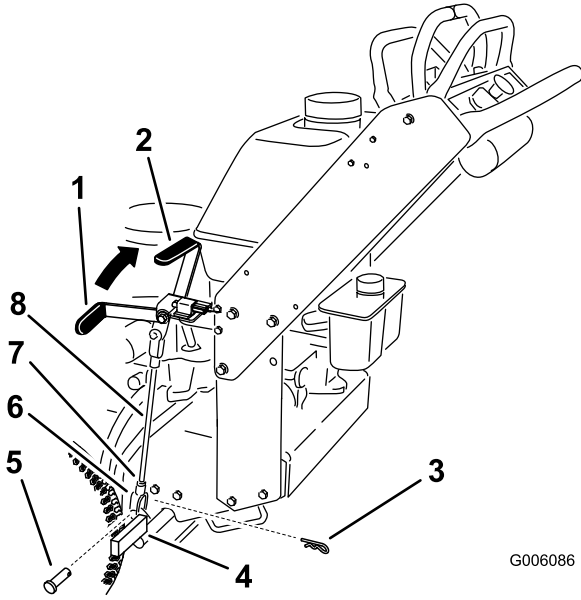

Figure 42

- | | |
|--------------------------------------------|---------------|
| 1. Parking brake lever (released position) | 5. Clevis pin |
| 2. 1 o'clock position | 6. Yoke |
| 3. Haripin cotter | 7. Jam Nut |
| 4. Lower brake lever | 8. Brake rod |

Belt Maintenance

Replacing the Mower Belt

Squealing when the belt is rotating, blades slipping when cutting grass, frayed belt edges, burn marks and cracks are signs of a worn deck belt. Replace the deck belt if any of these conditions are evident.

1. Disengage the PTO and set the parking brake.
2. Stop the engine, remove the key, and wait for all moving parts to stop before leaving the operating position.
3. Unlatch and remove the carrier frame cover.
4. Unlatch and remove the belt covers.
5. Remove the PTO drive belt. Refer to Replacing the PTO Drive Belt.
6. Disconnect the idler arm spring to relieve tension on the idler arm and idler pulley, then remove the worn mower belt (Figure 43 or Figure 44).
7. Install the new mower belt around the two outside spindle pulleys, the idler pulley, and in the lower groove of the double spindle pulley (Figure 43 or Figure 44).
8. Connect the idler arm spring (Figure 43 or Figure 44).
9. Install the PTO drive belt. Refer to Replacing the PTO Drive Belt.
10. Adjust the belt guide an 1/8 inch (3 mm) from the belt (Figure 43 or Figure 44).
11. Install the belt covers onto the cutting unit and secure the latches.
12. Install the carrier frame cover onto the cutting unit and secure the latches.

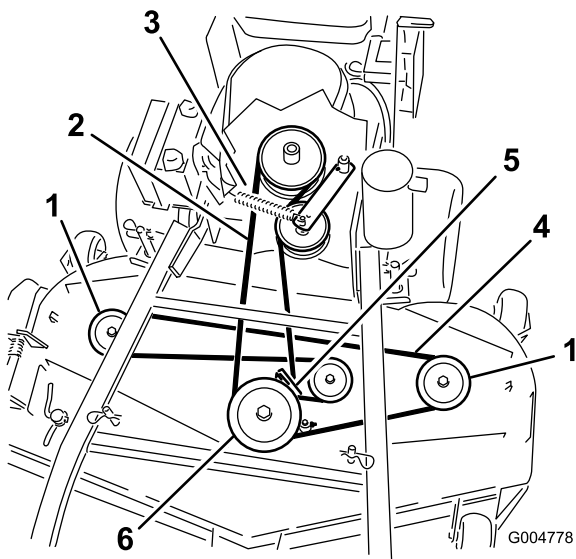

Figure 43

40 inch, 48 inch, and 52 inch Mower Deck shown

- | | |
|---------------------|--------------------------|
| 1. Outside pulley | 4. Mower deck belt |
| 2. PTO Drive Belt | 5. Belt guide |
| 3. Idler arm spring | 6. Center spindle pulley |

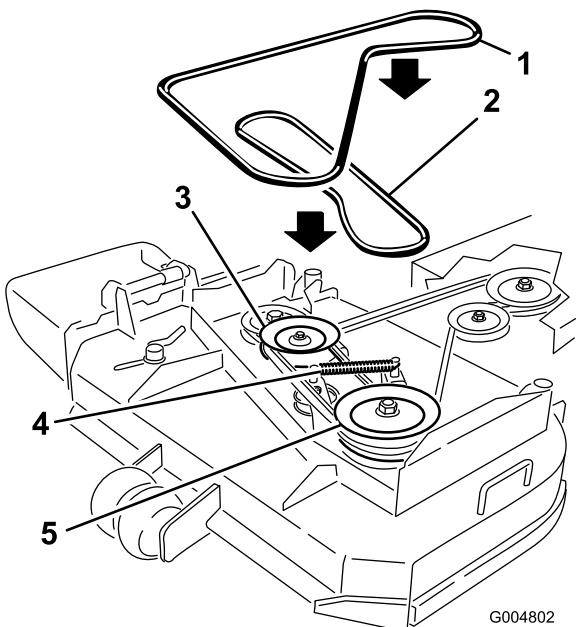

Figure 44

36 inch Mower Deck shown

- | | |
|----------------------|----------------------|
| 1. Mower deck belt | 4. Idler arm spring |
| 2. PTO Drive Belt | 5. Drive belt pulley |
| 3. Drive belt pulley | |

1. Disengage the PTO and set the parking brake.
2. Stop the engine, remove the key, and wait for all moving parts to stop before leaving the operating position.
3. Unlatch and remove the carrier frame cover.
4. Unlatch and remove the belt covers.
5. Remove the heat shield from the engine deck and carrier frame.
6. Roll the belt off of the center pulley on the mower deck (Figure 45). Refer to Figure 46 to roll the belt off left pulley for a 36 inch mower deck. Use caution when removing the belt as tension will increase because of the spring loaded idler pulley.
7. Remove the belt from the engine pulley and the spring loaded idler pulley (Figure 45). Refer to Figure 46 to remove the belt from the 36 inch mower deck pulleys.
8. Install the new belt onto the engine pulley and spring loaded idler pulley (Figure 45).
9. Roll the belt onto the center pulley on the mower deck (Figure 45). Use caution when install the belt as tension will increase because of the spring loaded idler pulley. Refer to Figure 46 to roll the new belt onto the left pulley for a 36 inch mower deck.
10. Install the heat shield to the engine deck and carrier frame.
11. Adjust the belt guide an 1/8 inch (3 mm) from the belt for 40, 48 and 52 inch mower decks (Figure 45).
12. Install the belt covers onto the cutting unit and secure the latches.
13. Install the carrier frame cover onto the carrier frame and secure the latches.

Replacing the PTO Drive Belt

Squealing when the belt is rotating, blades slipping when cutting grass, frayed belt edges, burn marks and cracks are signs of a worn drive belt. Replace the drive belt if any of these conditions are evident.

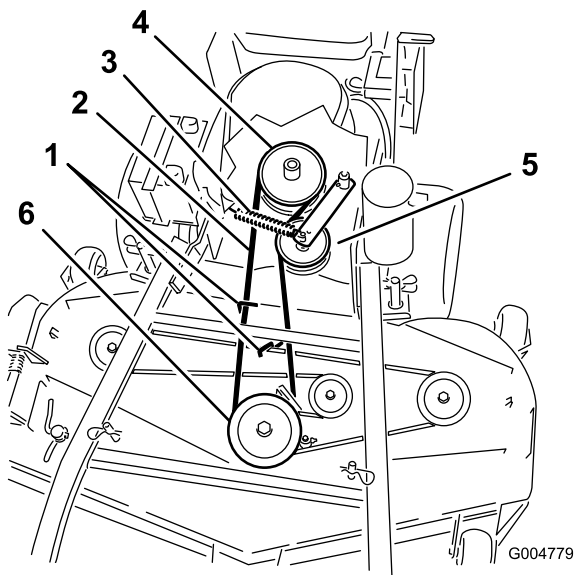

Figure 45

40 inch, 48 inch, and 52 inch Mower Deck shown

- | | |
|-------------------------|--------------------------------|
| 1. PTO drive belt guide | 4. PTO engagement pulley |
| 2. PTO drive Belt | 5. PTO drive belt idler pulley |
| 3. Idler spring | 6. Center spindle pulley |

Use Figure 47 for the idler position options.

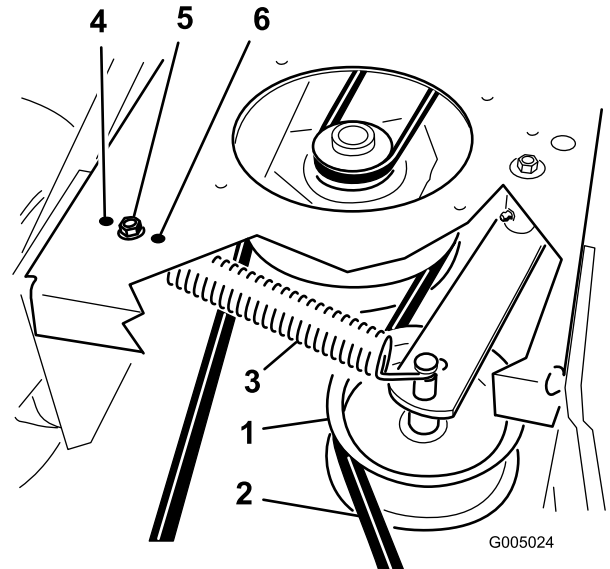

Figure 47

- | | |
|--------------------------------|----------------------------------------------|
| 1. PTO drive belt idler pulley | 4. Most tension for worn belts |
| 2. PTO drive Belt | 5. Medium tension for normal belt conditions |
| 3. Idler spring | 6. Least tension for new belts |

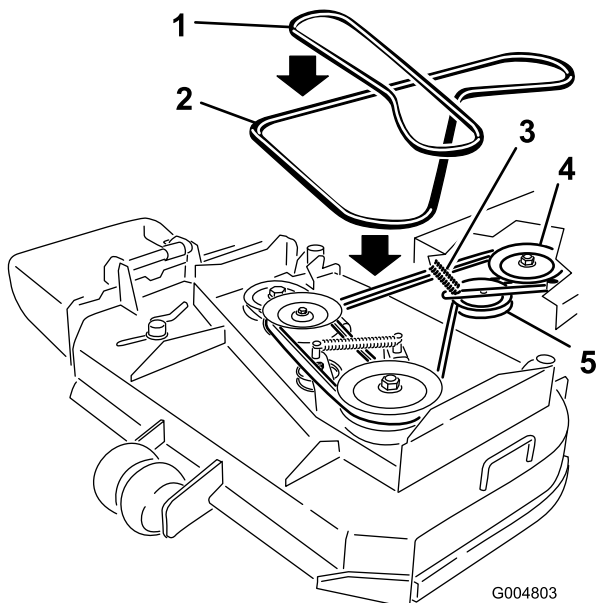

Figure 46

36 inch Mower Deck shown

- | | |
|-------------------------|------------------|
| 1. Mower deck belt | 4. Clutch pulley |
| 2. PTO Drive Belt | 5. Idler pulley |
| 3. Idler arm and spring | |

Replacing the Pump Drive Belt

1. Disengage the PTO and set the parking brake.
2. Stop the engine, remove the key, and wait for all moving parts to stop before leaving the operating position.
3. Remove PTO drive belt. Refer to Replacing the PTO Drive Belt in the Belt Maintenance, page 37.
4. Raise the machine and support it with jack stands.
5. Disconnect the clutch wire connector from the wire harness.
6. Disconnect the clutch retainer from the engine deck (Figure 48).

Adjusting the PTO Drive Belt Idler Spring Anchor

The position of the PTO idler can be adjusted to increase or decrease belt tension.

Controls System Maintenance

Adjusting the Motion Control Handle Positions

Adjusting the Right Side Motion Control Lever

If the motion control levers do not align horizontally, adjust the right side motion control lever.

Note: Adjust the horizontal alignment before the front to back alignment.

1. Disengage the PTO, move the right side motion control lever to the neutral position and set the parking brake.
2. Stop the engine, remove the key, and wait for all moving parts to stop before leaving the operating position.
3. Push the right motion control lever down out of locked neutral position (Figure 49).
4. Check if it aligns horizontally with the left motion control lever (Figure 49).

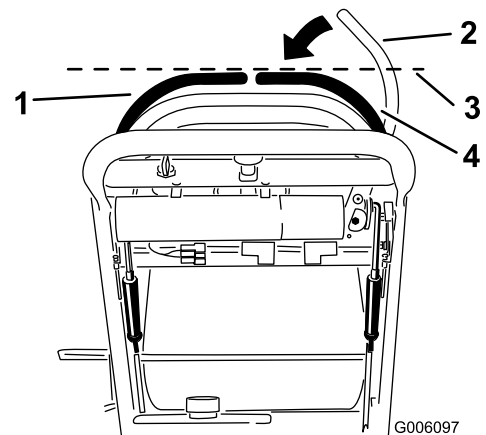

Figure 49

1. Left motion control lever
2. Right motion control lever in neutral locked position
3. Check the horizontal alignment here
4. Right motion control lever

5. To adjust the right motion control lever horizontally, the cam needs to be adjusted.
6. Remove the cover under the control panel.
7. Loosen the nut and bolt holding the cam (Figure 50).
8. Adjust the cam until it aligns with the left motion control lever and tighten the nut and bolt for the cam.

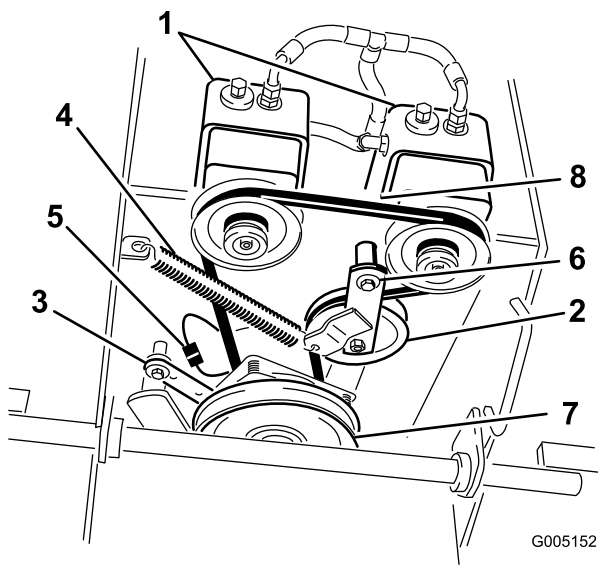
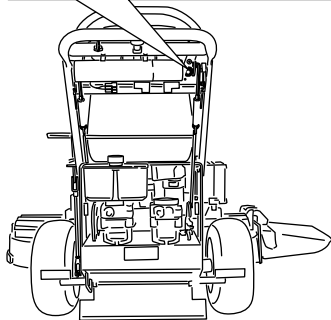
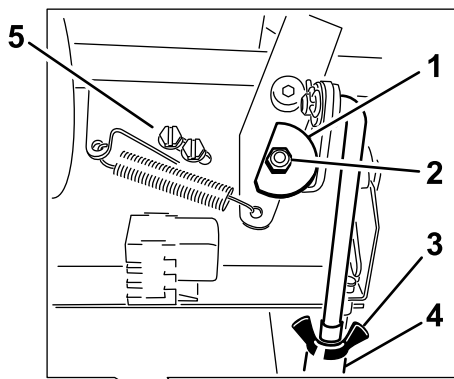

Figure 48

1. Hydraulic pumps
2. Idler pulley
3. Clutch retainer
4. Tension spring
5. Clutch wire connector
6. Pivot bolt
7. Drive pulley
8. Pump drive belt

7. Unhook the idler spring from the frame (Figure 48).
8. Install the new belt around clutch and the two drive pulleys.
9. Install the idler spring between idler arm and frame bracket (Figure 48).
10. Install the clutch retainer to the engine deck (Figure 48).
11. Connect the clutch wire connector to the wire harness.
12. Install the PTO drive belt.



G006095

Figure 50

- | | |
|-----------------|------------------|
| 1. Cam | 4. Turnbuckle |
| 2. Nut and bolt | 5. Switch screws |
| 3. Wing nut | |

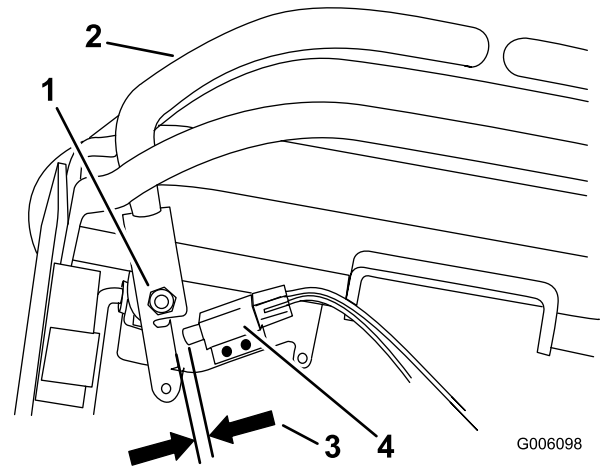

Figure 51

- | | |
|---------------------------------------------------------------|---------------------------------------------------------------|
| 1. Right side motion control lever pivot shown under controls | 3. 1/8 inch (3mm) gap needed between switch and control lever |
| 2. Right side motion control lever | 4. Switch lever |

Adjusting the Neutral Position for the Motion Control Levers

Important: Ensure the tracking of the mower is correct after adjusting the motion control levers. After adjusting the tracking, the motion control levers may not align the exactly front to back (Figure 52).

If the motion control levers do not align front to back, or the right side control lever does not move easily into the neutral lock position, adjustment is required. Adjust each lever and control rod separately.

Note: Adjust the horizontal alignment before the front to back alignment.

1. After the horizontal alignment is finished, check the front to back alignment (Figure 52).

9. After the cam is adjusted, the lever switch needs to be checked.
10. Check the gap between the control lever and switch as shown in Figure 51. The gap needs to be an 1/8 inch (3mm).
11. If needed, loosen the screws holding the switch and adjust the switch.
12. Tighten the screws and install the cover under the control panel.

Hydraulic System Maintenance

Servicing the Hydraulic System

Checking the Hydraulic Fluid

Check the hydraulic fluid level as follows:

- Check the hydraulic fluid level before engine is first started.
- Check the hydraulic fluid level after first 8 operating hours.
- Check the hydraulic fluid level after every 25 operating hours.

Fluid Type: Mobil 1 15W-50 synthetic motor oil or equivalent synthetic oil.

Important: Use oil specified or equivalent. Other fluids could cause system damage.

Hydraulic System Oil Capacity: 67 oz. (2.0 l)

Note: There are two ways of checking the hydraulic oil. One is when the oil is warm and one is when the oil is cold. The baffle inside the tank has two levels depending if the oil is warm or cold.

1. Position machine on a level surface.
2. Disengage the power take off (PTO) and shut off the engine.
3. Wait for all moving parts to stop before leaving the operating position and then set the parking brake.
4. Clean area around cap and filler neck of hydraulic tank (Figure 54).

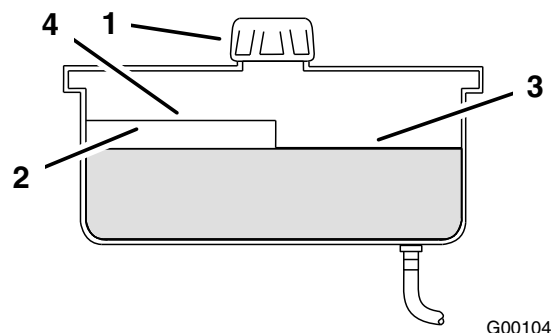

Figure 54

1. Cap
2. Baffle
3. Cold fluid level-full
4. Hot fluid level-full

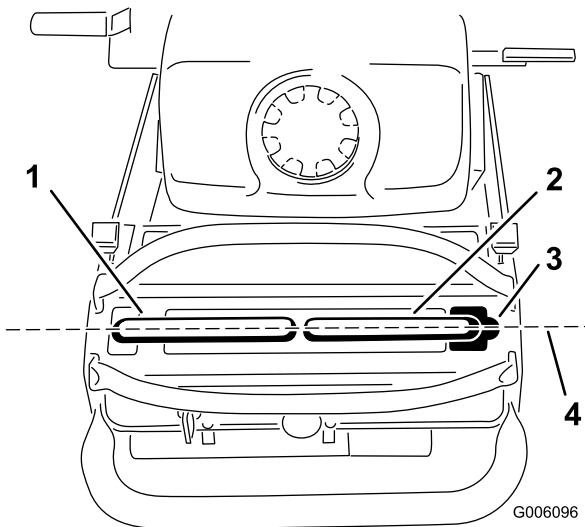

Figure 52

1. Left motion control lever
2. Right motion control lever
3. Neutral locked position
4. Align the control levers front to back here

2. Loosen the wing nuts on the right control rod and rotate the turnbuckle in or out to ensure the right side control lever is centered in the neutral lock position. Secure the turnbuckle in position with the wing nuts (Figure 53).
3. Loosen the wing nuts on the left control rod and rotate the turnbuckle in or out to change the tracking. Secure the turnbuckle in position with the wing nuts (Figure 53).

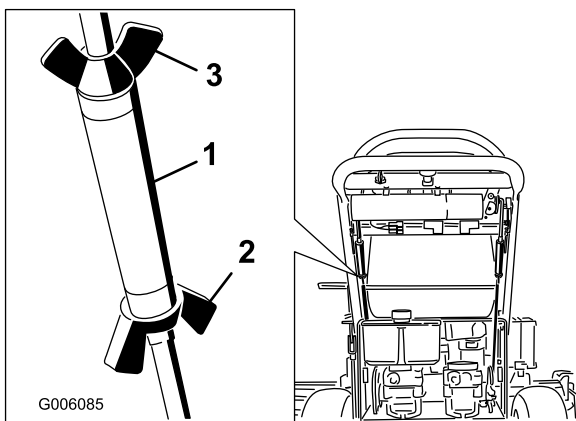

Figure 53

1. Turnbuckle
2. Bottom wing nut
3. Top wing nut (left hand threaded)

4. Check for proper tracking. Adjust the left control rod if a change is needed. Refer to Adjusting the Tracking in the Operation Section.

5. Remove cap from filler neck. Look inside to check the fluid level in the reservoir. (Figure 54).

6. Add fluid to the reservoir until it reaches the cold level of the baffle.
7. Run the machine at low idle for 15 minutes to allow any air to purge out of the system and warm fluid. Refer to Starting and Stopping the Engine.
8. Recheck the fluid level while the fluid is warm. If required, add fluid to the reservoir until it reaches the hot level of the baffle.

Note: The fluid level should be to the top of the hot level of the baffle, when the fluid is warm (Figure 54).

9. Install cap on filler neck.



Hydraulic fluid escaping under pressure can penetrate skin and cause injury.

- If hydraulic fluid is injected into the skin it must be surgically removed within a few hours by a doctor familiar with this type of injury. Gangrene may result if this is not done.
- Keep body and hands away from pin hole leaks or nozzles that eject high pressure hydraulic fluid.
- Use cardboard or paper to find hydraulic leaks.
- Safely relieve all pressure in the hydraulic system before performing any work on the hydraulic system.
- Make sure all hydraulic fluid hoses and lines are in good condition and all hydraulic connections and fittings are tight before applying pressure to hydraulic system.

Replacing the Hydraulic Filter



Hot hydraulic fluid can cause severe burns.

Allow the hydraulic fluid to cool before performing any maintenance to the hydraulic system.

Change the hydraulic filter as follows:

- After the first 8 operating hours.
- After every 200 operating hours or yearly before storage.

1. Disengage the PTO and set the parking brake.
2. Stop the engine and wait for all moving parts to stop before leaving the operating position.

Important: Do not substitute automotive oil filter or severe hydraulic system damage may result.

3. Remove hydraulic reservoir cap and temporarily cover opening with a plastic bag and rubber band to prevent all hydraulic fluid from draining out.
4. Locate the filter under the fuel tank and place drain pan under filter (Figure 55).

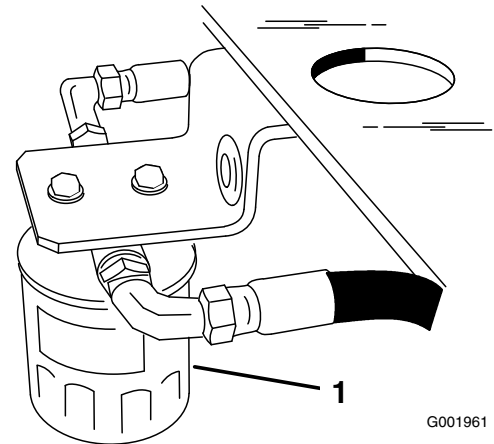

Figure 55

5. Remove the old filter and wipe the filter adapter gasket surface clean (Figure 56).
6. Apply a thin coat hydraulic fluid to the rubber gasket on the replacement filter.
7. Install replacement hydraulic filter onto the filter adapter. Do not tighten.
8. Remove plastic bag from reservoir opening and allow filter to fill with hydraulic fluid.
9. When the hydraulic filter is full, turn the oil filter clockwise until the rubber gasket contacts the filter adapter, then tighten the filter an additional 1/2 turn (Figure 56).

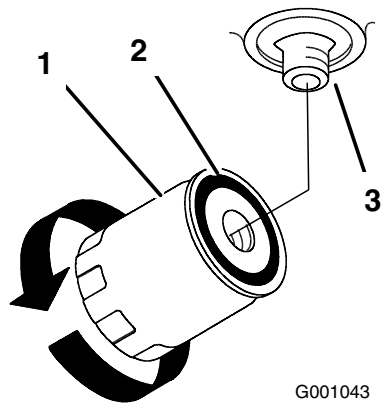

Figure 56

1. Hydraulic filter
2. Gasket
3. Adapter

10. Clean up any spilled fluid.
11. Check the fluid in the reservoir, add fluid to the tank until it reaches the cold baffle of the tank.

Important: Use oil specified or equivalent. Other fluids could cause system damage.

12. Start engine and let run for about two minutes to purge air from the system. Stop the engine and check for leaks. If one or both wheels will not drive, refer to Bleeding Hydraulic System.
13. Recheck level and add fluid, if required. **Do not overfill.**

Bleeding the Hydraulic System

The traction system is self bleeding, however, it may be necessary to bleed the system if fluid is changed or after work is performed on the system.

1. Disengage the PTO and set the parking brake.
2. Stop the engine and wait for all moving parts to stop before leaving the operating position.
3. Raise the rear of the machine up onto jack stands high enough to raise the drive wheels off the ground.
4. Start the engine and move the throttle control to idle position.

If the drive wheel does not rotate, it is possible to assist the purging of the system by carefully rotating the tire in the forward direction.

5. Check the hydraulic fluid level as it drops add fluid as required to maintain the proper level.
6. Repeat this procedure for the opposite wheel.
7. Thoroughly clean the area around each of the charge pump housings.

Checking the Hydraulic Lines

After every 100 operating hours, check hydraulic lines and hoses for leaks, loose fittings, kinked lines, loose mounting supports, wear, weather and chemical deterioration. Make necessary repairs before operating.

Note: Keep areas around hydraulic system clean from grass and debris build up.



Hydraulic fluid escaping under pressure can penetrate skin and cause injury.

- If hydraulic fluid is injected into the skin it must be surgically removed within a few hours by a doctor familiar with this type of injury. Gangrene may result if this is not done.
- Keep body and hands away from pin hole leaks or nozzles that eject high pressure hydraulic fluid.
- Use cardboard or paper to find hydraulic leaks.
- Safely relieve all pressure in the hydraulic system before performing any work on the hydraulic system.
- Make sure all hydraulic fluid hoses and lines are in good condition and all hydraulic connections and fittings are tight before applying pressure to hydraulic system.

Mower Deck Maintenance

Servicing the Cutting Blades

To ensure a superior quality of cut, keep the blades sharp. For convenient sharpening and replacement, you may want to keep extra blades on hand.



A worn or damaged blade can break, and a piece of the blade could be thrown into the operator's or bystander's area, resulting in serious personal injury or death.

- Inspect the blades periodically for wear or damage.
- Replace a worn or damaged blade.

Before Inspecting or Servicing the Blades

Park the machine on a level surface, disengage the blades and set the parking brake. Turn the ignition key to off. Remove the key and disconnect the spark plug wires from the spark plugs.

Inspecting the Blades

Inspect the blades every 8 hours.

1. Inspect the cutting edges (Figure 57). If the edges are not sharp or have nicks, remove and sharpen the blades. Refer to Sharpening the Blades.

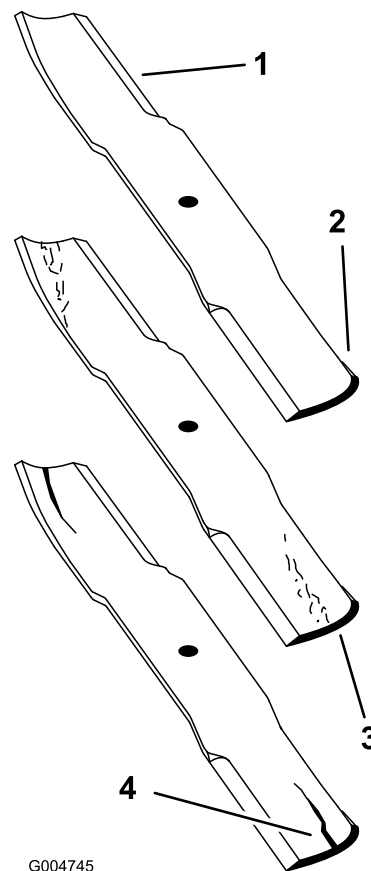

G004745

Figure 57

1. Cutting Edge
2. Sail
3. Wear/slot forming in curved area
4. Crack in the curved area

2. Inspect the blades, especially the curved area (Figure 57). If you notice any cracks, wear, or a slot forming in this area (item 3 in Figure 57), immediately install a new blade.

Checking for Bent Blades

1. Disengage the PTO, move the motion control levers to the neutral locked position and set the parking brake.
2. Stop the engine, remove the key, and wait for all moving parts to stop before leaving the operating position.
3. Rotate the blades until the ends face forward and backward. Measure from a level surface to the cutting edge, position **A**, of the blades (Figure 58). Note this dimension. For 36 inch mower decks use Figure 59.

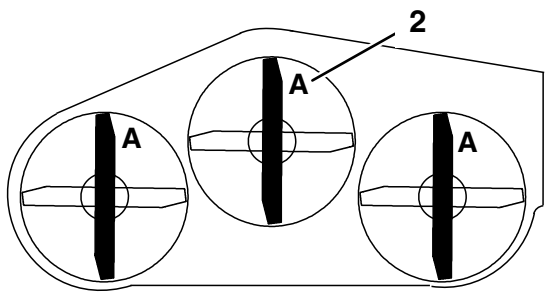

G000975

Figure 58

40 inch, 48 inch, and 52 inch Mower Deck shown

1. Measure here from blade to hard surface
2. Position A

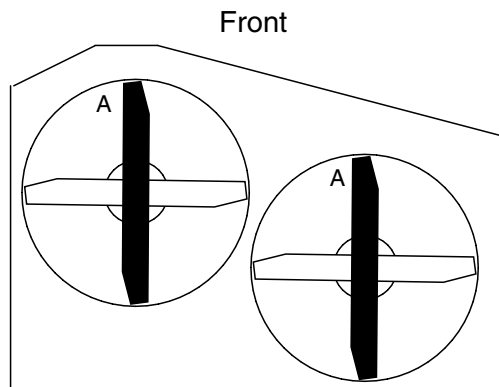

G000288

Figure 59

36 inch Mower Deck shown

4. Rotate the opposite ends of the blades forward.
5. Measure from a level surface to the cutting edge of the blades at the same position as in step 3 above. The difference between the dimensions obtained in steps 3 and 4 must not exceed 1/8 inch (3 mm). If this dimension exceeds 1/8 inch (3 mm), the blade is bent and must be replaced; refer to Removing the Blades and Installing the Blades.



A blade that is bent or damaged could break apart and could seriously injure or kill you or bystanders.

- Always replace bent or damaged blade with a new blade.
- Never file or create sharp notches in the edges or surfaces of blade.

Removing the Blades

Blades must be replaced if a solid object is hit, if the blade is out of balance or is bent. To ensure optimum performance and continued safety conformance of the machine, use genuine Toro replacement blades. Replacement blades made by other manufacturers may result in non-conformance with safety standards.

1. Hold the blade end using a rag or thickly-padded glove.
2. For 40 and 48 inch mower decks, remove the blade bolt, curved washer, and blade from the spindle shaft (Figure 60).

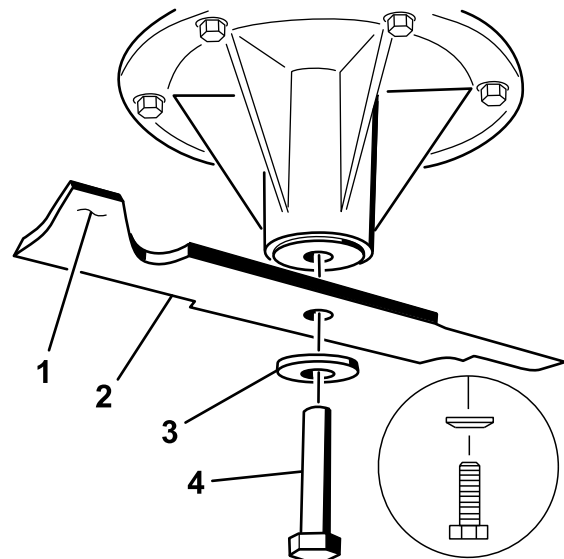

G004536

Figure 60

40 inch and 48 inch Mower Decks

- | | |
|-----------------------|------------------|
| 1. Sail Area of Blade | 3. Curved washer |
| 2. Blade | 4. Blade Bolt |

3. For 36 and 52 inch mower decks, remove the blade bolt, curved washer, blade stiffener, and blade from the spindle shaft (Figure 61).

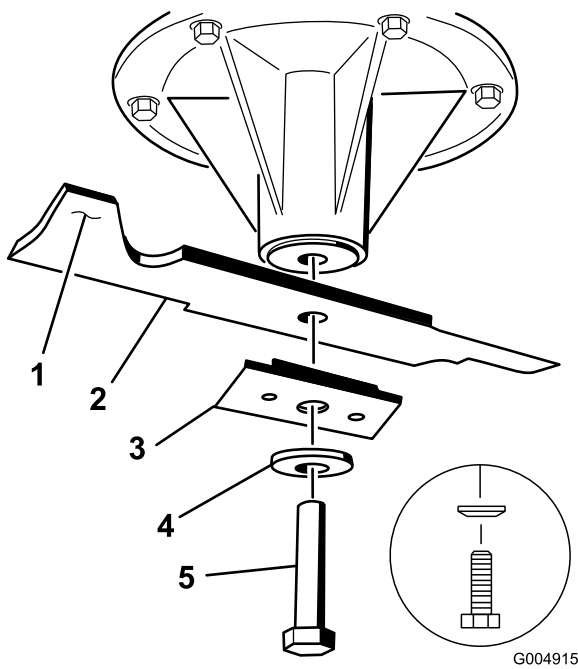

Figure 61

36 inch and 52 inch Mower Decks

- | | |
|-----------------------|------------------|
| 1. Sail Area of Blade | 4. Curved washer |
| 2. Blade | 5. Blade Bolt |
| 3. Blade stiffener | |

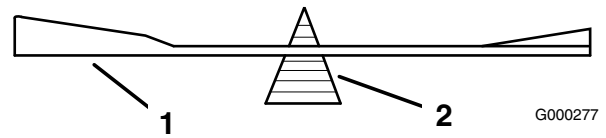

Figure 63

- | | |
|----------|-------------|
| 1. Blade | 2. Balancer |
|----------|-------------|

Sharpening the Blades

1. Use a file to sharpen the cutting edge at both ends of the blade (Figure 62). Maintain the original angle. The blade retains its balance if the same amount of material is removed from both cutting edges.

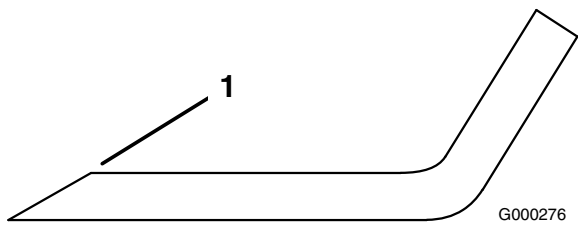

Figure 62

1. Sharpen at original angle
-
2. Check the balance of the blade by putting it on a blade balancer (Figure 63). If the blade stays in a horizontal position, the blade is balanced and can be used. If the blade is not balanced, file some metal off the end of the sail area only (Figure 60). Repeat this procedure until the blade is balanced.

Installing the Blades

1. Install the blade onto the spindle shaft (Figure 60).

Important: The sail part of the blade must be pointing upward, toward the inside of the mower to ensure proper cutting (Figure 60).
2. For 40 inch and 48 inch mower decks, install the blade, curved washer, and blade bolt (Figure 60).
3. For 36 inch and 52 inch mower decks, install the blade, stiffener, curved washer, and blade bolt (Figure 61).
4. Torque the blade bolt to 85-110 ft-lb (115-140 N-m).

Correcting the Mower Quality of Cut

If one deck blade cuts lower than the other, correct as follows.

Note: Tire air pressure is critical in these procedures. Make sure all tires have correct pressure.

1. Disengage the PTO and set the parking brake.
2. Stop the engine, remove the key, and wait for all moving parts to stop before leaving the operating position. Disconnect the spark plug wire(s) from the spark plug(s).
3. Adjust the tire pressure in the rear tires to specifications; refer to Drive System Maintenance , page 33 .
4. Check that the blades and spindle shafts are not bent. Refer to Checking for Bent Blades.
5. Set the height-of-cut to the 4 inch (101.6 mm) position. Refer to Adjusting the Height-Of-Cut in Operation , page 12.
6. Perform the steps in the following sections Frame Set Up, Checking Front-to-Rear Pitch, and Checking Side-to-Side Leveling.

Frame Set Up

Checking the Carrier Frame and Engine Deck Alignment

Note: Misalignment can cause excess wear on the PTO drive belt.

1. Disengage the PTO and set the parking brake.
2. Stop the engine, remove the key, and wait for all moving parts to stop before leaving the operating position.
3. Place a long straight edge on top of the engine deck as shown in Figure 64.
4. At the carrier frame cross channel, measure the height at location **A** (Figure 64). This measurement must be 1-5/16 inch (33 mm), plus or minus a 1/4 inch (6 mm).
5. If the height at location **A** is not correct, adjustment is needed.
6. Loosen the carrier frame mounting bolts on both sides of the machine (Figure 64).
7. Align the carrier frame and engine deck to match 1-5/16 inch (33 mm), plus or minus a 1/4 inch (6 mm) at location **A** (Figure 64).
8. Tighten the carrier frame mounting bolts on both sides of the machine.

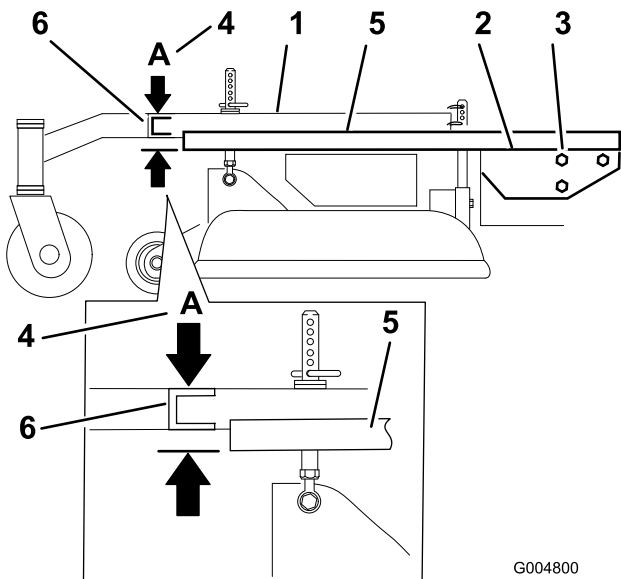

Figure 64

- | | |
|---------------------------------|-----------------------------------------------------|
| 1. Carrier Frame | 4. Location A, 1-5/16 inch (33 mm) ±1/4 inch (6 mm) |
| 2. Top of engine deck | 5. Straight edge |
| 3. Carrier frame mounting bolts | 6. Carrier frame cross channel |

Checking the Engine Deck Height

1. Disengage the PTO and set the parking brake.
2. Stop the engine, remove the key, and wait for all moving parts to stop before leaving the operating position.
3. Adjust the tire pressure in the rear tires to specifications; refer to Drive System Maintenance , page 33 .
4. Measure engine deck height at location **A** (Figure 65).
5. Measure engine deck height at location **B** (Figure 65).
6. If the height at location **A** and **B** are not the same, change tire pressure slightly to make them the same.

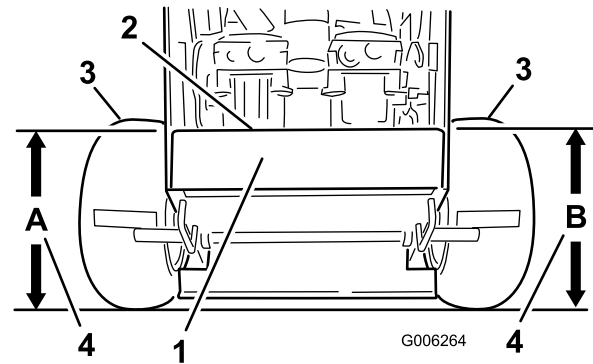

Figure 65

- | | |
|-------------------------|-------------------------------------|
| 1. Back view of machine | 3. Tires |
| 2. Top of engine deck | 4. Same height at locations A and B |

Checking the Carrier Frame Front-to-Rear Pitch

The carrier frame must have a pitch between 1/8 inch (3 mm) to 3/8 inch (9 mm) over the length of 24 inches (61 cm) on the carrier frame (Figure 66).

1. Measure out 24 inches (61 cm) on the carrier frame (Figure 66).

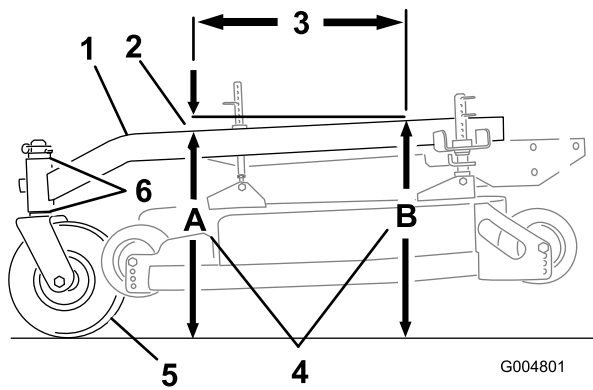

Figure 66

- | | |
|-------------------------------------------------------------------|----------------------------------------------|
| 1. Carrier Frame | 4. Height at locations A and B |
| 2. 1/8 inch -3/8 inch (3-10 mm) pitch over 24 inch (61 cm) length | 5. Caster Wheel |
| 3. 24 inches (61 cm) | 6. Caster spacers |

make it level. The tire pressure may also be adjusted slightly to make it level.

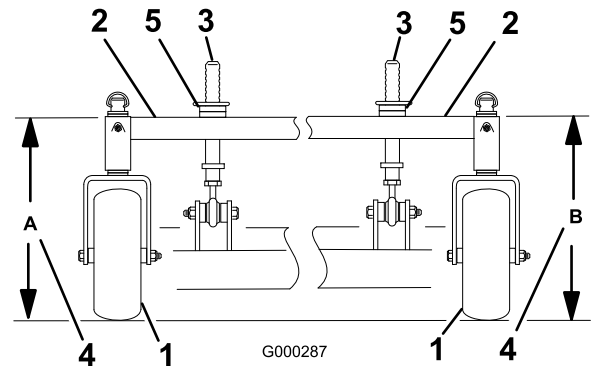

Figure 67

- | | |
|-----------------------------|---------------------------------------------------|
| 1. Caster Wheel | 4. Same height at locations A and B |
| 2. Carrier Frame | 5. Caster spacers |
| 3. Front height-of-cut pins | |

2. Measure carrier frame height at location **A** (Figure 66).
3. Measure carrier frame height at location **B** (Figure 66).
4. The height at location **A** must be an 1/8-3/8 inch (3 mm -10 mm) lower than location **B** (Figure 66).
5. If the carrier frame is not correct, move caster spacers to make it an 1/8-3/8 inch (3 -10 mm) pitch (Figure 66). Move spacers from top or bottom to make the correct pitch.
6. The tire pressure may also be adjusted slightly to make an 1/8-3/8 inch (3 -10 mm) pitch.

Checking the Carrier Frame Side-to-Side Height

The carrier frame needs to be parallel side-to-side from the ground.

1. Disengage the PTO and set the parking brake.
2. Stop the engine, remove the key, and wait for all moving parts to stop before leaving the operating position.
3. Adjust the tire pressure in the rear tires to specifications; refer to Drive System Maintenance , page 33 .
4. Measure carrier frame height at location **A** (Figure 67).
5. Measure carrier frame height at location **B** (Figure 67).
6. If the carrier frame height is not the same move spacers from top or bottom of caster wheel, to

Checking the Mower Deck Front-to-Rear Pitch

1. Adjust the tire pressure in the rear tires to specifications; refer to Drive System Maintenance , page 33 .
2. Position one blade front-to-rear. Measure at **A** and **B** locations from a level surface to the cutting edge of the blade tips (Figure 68 or Figure 69). For 36 inch mower decks use Figure 69.
3. The mower blade should be a 1/4 inch (6 mm) lower in front at **A** than in the rear at **B**. Rotate blades and repeat for other blades. If it is not correct, proceed to Changing the Deck Front-to-Rear Pitch.

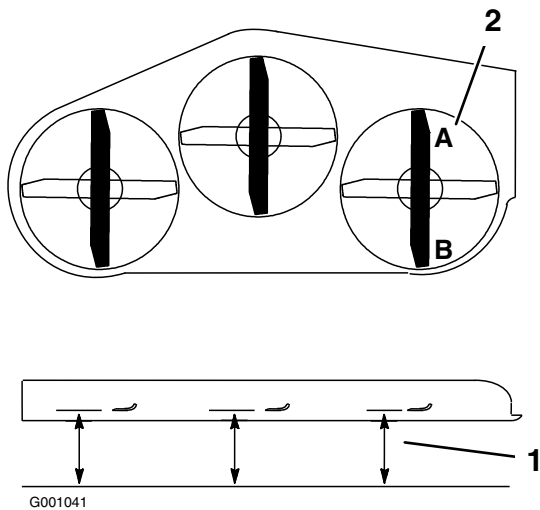

Figure 68

40 inch, 48 inch, and 52 inch Mower Deck shown

1. Measure blade at points **A** and **B**
2. Measure from a level surface

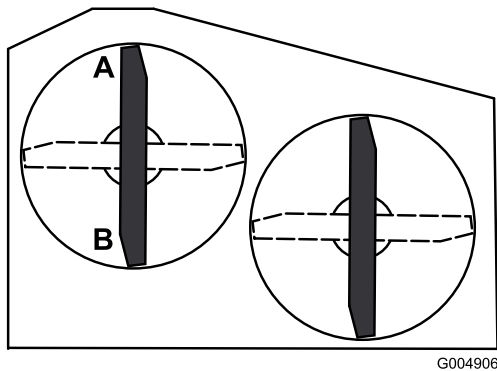

Figure 69

36 inch Mower Deck shown

Changing the Mower Deck Front-to-Rear Pitch

Changing the front-to-rear pitch is done by adjusting the front height-of-cut posts.

1. To change the front-to-rear pitch, the front height-of-cut posts can be adjusted (Figure 70).

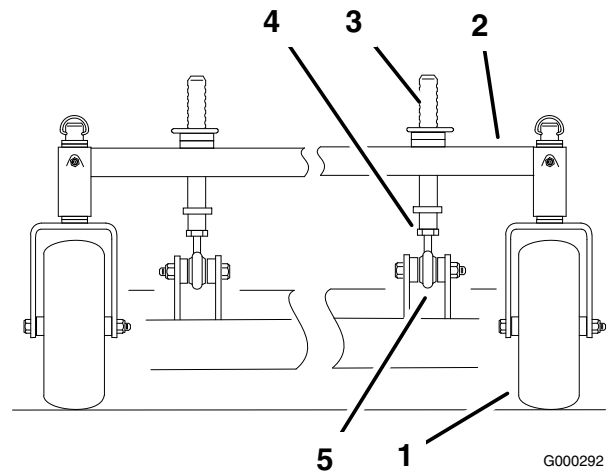

Figure 70

1. Caster Wheel
2. Carrier Frame
3. Front height-of-cut pins
4. Jam nut
5. Ball joint

2. To raise the front of the deck, loosen jam nut and rotate the front pin clockwise (Figure 70).
3. To lower the front of the deck, loosen jam nut and rotate the front pin counter clockwise (Figure 70).
4. Position the blades front-to-rear. Measure at **C** and **D** locations (Figure 68) from a level surface to the cutting edge of the blades.
5. Check the side-to-side leveling of the cutting unit.
6. Tighten the jam nuts (Figure 70).

Checking the Mower Deck Side-to-Side Height

1. Adjust the rear tire pressure to specifications; refer to Drive System Maintenance , page 33 .
2. Position the blades side-to-side. Measure at **C** and **D** locations from a level surface to the cutting edge of blade tips (Figure 71). For 36 inch mower decks use Figure 72.

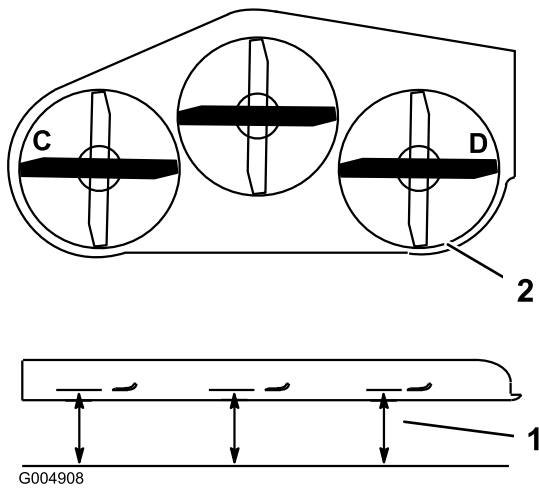

Figure 71

40 inch, 48 inch, and 52 inch Mower Deck shown

1. Measure from a level surface
2. Measure blade at points C and D

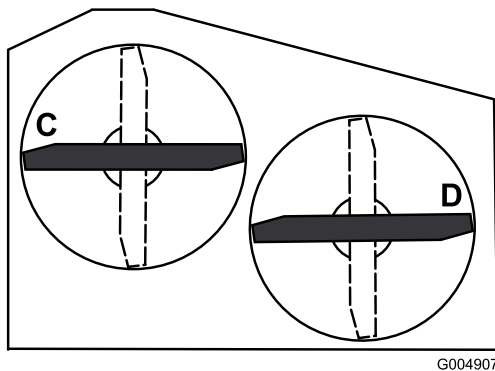

Figure 72

36 inch Mower Deck shown

3. The difference between measurements C and D should be no more than 1/4 inch (6 mm).

Changing the Mower Deck Side-to-Side Height

Changing the side-to-side height is done by adjusting the rear tire pressure and caster spacers.

1. Change the rear tire pressure. Do this to the corresponding side that needs adjustment.
2. Adjust the caster spacer.
3. Recheck the front-to-rear pitch and side to side leveling of the cutting unit.

Matching Height of Cut

1. Check the rear tire pressure.
2. Set the height-of-cut to the 4 inch (101.6 mm) position following the height-of-cut decal.

3. With the machine on level surface, position one blade front-to-rear. Measure at A and from level surface to the cutting edge of the blade tips (Figure 73). For 36 inch mower decks use Figure 74.

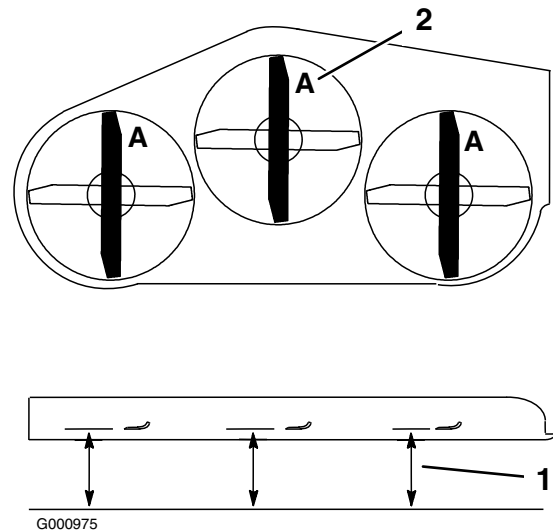

Figure 73

40 inch, 48 inch, and 52 inch Mower Deck shown

1. Measure from a level surface
2. Measure blade at point A

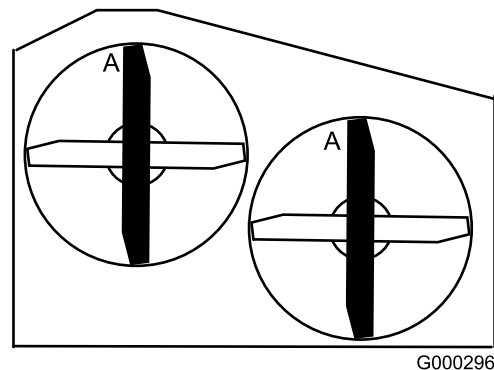

Figure 74

36 inch Mower Deck shown

4. The measurement should be 4 inch (101.6 mm).
5. If it does not measure correctly:
 - A. Adjust the rear tire pressure.
 - B. Adjust the caster fork spacers.
 - C. Adjust the front mower deck support pins.
6. Check the carrier frame front-to-rear pitch.

Replacing the Grass Deflector

position and ensure that it rotates into the full down position.



An uncovered discharge opening could allow the lawn mower to throw objects in the operator's or bystander's direction and result in serious injury. Also, contact with the blade could occur.

Never operate the lawn mower unless you install a cover plate, a mulch plate, grass deflector or bagger.

1. Remove the locknut, bolt, spring and spacer holding the deflector to the pivot brackets (Figure 75). Remove damaged or worn grass deflector.

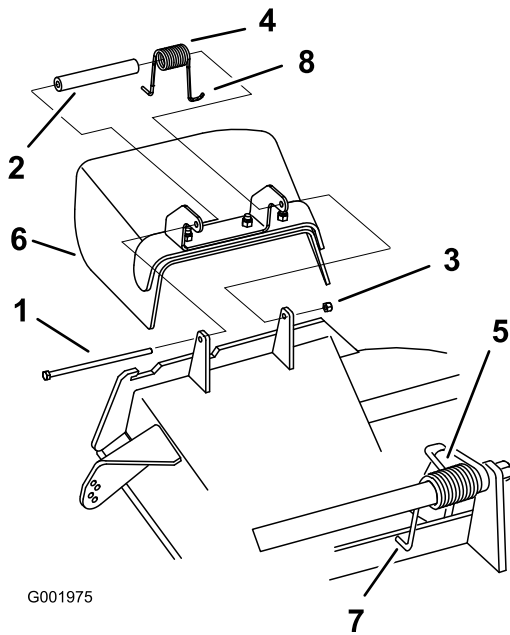

Figure 75

- | | |
|------------|-------------------------------------------------------------------|
| 1. Bolt | 5. Spring installed |
| 2. Spacer | 6. Grass Deflector |
| 3. Locknut | 7. L end of spring, place behind deck edge before installing bolt |
| 4. Spring | 8. J hook end of spring |

2. Place spacer and spring onto grass deflector. Place the **L** end of spring behind deck edge.

Note: Make sure the **L** end of spring is installed behind deck edge before installing the bolt as shown in Figure 75.

3. Install bolt and nut. Place the **J** hook end of spring around grass deflector (Figure 75).

Important: The grass deflector must be able to rotate. Lift the deflector up to the full open

Cleaning

Cleaning Under the Mower

Remove the grass buildup under the mower daily.

1. Disengage the PTO, move the motion control levers to the neutral locked position and set the parking brake.
2. Stop the engine, remove the key, and wait for all moving parts to stop before leaving the operating position.
3. Raise the front of the machine and use jack stands to support the mower.

Waste Disposal

Engine oil, batteries, hydraulic oil, and engine coolant are pollutants to the environment. Dispose of these according to your state and local regulations.

Storage

Cleaning and Storage

1. Disengage the power take off (PTO), set the parking brake, and turn the ignition key to off. Remove the key.
2. Remove grass clippings, dirt, and grime from the external parts of the entire machine, especially the engine. Clean dirt and chaff from the outside of the engine's cylinder head fins and blower housing.

Important: You can wash the machine with mild detergent and water. Do not pressure wash the machine. Avoid excessive use of water, especially near the drive system and engine. Pressure washing can force dirt and water into critical parts, such as spindle bearings and electrical switches.

3. Check the brake; refer to Servicing the Brake in Brake Maintenance , page 36.
 4. Service the air cleaner; refer to Servicing the Air Cleaner in Engine Maintenance , page 25.
 5. Grease the machine; refer to Greasing and Lubrication in Lubrication , page 24.
 6. Change the engine oil; refer to Servicing the Engine in Engine Maintenance , page 25.
 7. Check the tire pressure; refer to Checking the Tire Pressure in Drive System Maintenance , page 33.
 8. For long-term storage:
 - A. Add stabilizer/conditioner additive to fuel in the tank.
 - B. Run engine to distribute conditioned fuel through the fuel system (5 minutes).
 - C. Stop engine, allow to cool and drain the fuel tank; refer to Servicing the Fuel Tank in Fuel System Maintenance , page 29, or operate engine until it stops.
 - D. Restart engine and run until it stops. Repeat, on Choke until engine will not restart.
 - E. Dispose of fuel properly. Recycle as per local codes.
- Note:** Do not store stabilizer/conditioned gasoline over 90 days.
9. Remove the spark plug(s) and check its condition; refer to Servicing the Spark Plug in Engine Maintenance , page 25. With the spark plug(s) removed from the engine, pour two tablespoons of engine oil into the spark plug hole. Now use the starter to crank the engine and distribute the oil

inside the cylinder. Install the spark plug(s). Do not install the wire on the spark plug(s).

10. Check and tighten all bolts, nuts, and screws. Repair or replace any part that is damaged or defective.
11. Paint all scratched or bare metal surfaces. Paint is available from your Authorized Service Dealer.
12. Store the machine in a clean, dry garage or storage area. Remove the key from the ignition switch and keep it in a memorable place. Cover the machine to protect it and keep it clean.

Troubleshooting

Problem	Possible Cause	Corrective Action
Engine will not start, starts hard, or fails to keep running.	<ol style="list-style-type: none"> 1. Fuel tank is empty. 2. Choke is not on. 3. Air cleaner is dirty. 4. Spark plug wire is loose or disconnected. 5. Spark plug is pitted, fouled, or the gap is incorrect. 6. Dirt in the fuel filter. 7. Dirt, water, or stale fuel is in the fuel system. 8. The gap between the neutral switch bolt and the switch is not correct. 	<ol style="list-style-type: none"> 1. Fill fuel tank with gasoline. 2. Move the choke lever to choke position. 3. Service the air cleaner element. 4. Install wire on spark plug. 5. Install a new, correctly gapped spark plug. 6. Replace the fuel filter. 7. Contact an Authorized Service Dealer. 8. Contact an Authorized Service Dealer.
Engine loses power.	<ol style="list-style-type: none"> 1. Engine load is excessive. 2. Air cleaner is dirty. 3. Oil level in the crankcase is low. 4. Cooling fins and air passages under the engine blower housing are plugged. 5. Spark plug is pitted, fouled, or the gap is incorrect. 6. Vent hole in the fuel cap is plugged. 7. Dirt in the fuel filter. 8. Dirt, water, or stale fuel is in the fuel system. 	<ol style="list-style-type: none"> 1. Reduce the ground speed. 2. Service the air cleaner. 3. Add oil to the crankcase. 4. Remove the obstruction from the cooling fins and air passages. 5. Install a new, correctly gapped spark plug. 6. Clean or replace the fuel cap. 7. Replace the fuel filter. 8. Contact an Authorized Service Dealer.
Engine overheats.	<ol style="list-style-type: none"> 1. Engine load is excessive. 2. Oil level in the crankcase is low. 3. Cooling fins and air passages under the engine blower housing are plugged. 	<ol style="list-style-type: none"> 1. Reduce the ground speed. 2. Add oil to the crankcase. 3. Remove the obstruction from the cooling fins and air passages.
Machine does not drive.	<ol style="list-style-type: none"> 1. Hydraulic oil reservoir low. 2. Air in the hydraulic system. 3. Pump drive belt slipping. 4. Pump drive belt idler spring missing. 	<ol style="list-style-type: none"> 1. Add hydraulic oil to the reservoir. 2. Bleed the air out the hydraulic system. 3. Replace the pump drive belt. 4. Replace the pump drive belt idler spring.
Abnormal vibration.	<ol style="list-style-type: none"> 1. Cutting blade(s) is/are bent or unbalanced. 2. Blade mounting bolt is loose. 3. Engine mounting bolts are loose. 4. Loose engine pulley, idler pulley, or blade pulley. 5. Engine pulley is damaged. 6. Blade spindle is bent. 	<ol style="list-style-type: none"> 1. Install new cutting blade(s). 2. Tighten the blade mounting bolt. 3. Tighten the engine mounting bolts. 4. Tighten the appropriate pulley. 5. Contact an Authorized Service Dealer. 6. Contact an Authorized Service Dealer.
Uneven cutting height.	<ol style="list-style-type: none"> 1. Blade(s) not sharp. 2. Cutting blade(s) is/are bent. 3. Mower is not level. 4. Mower pitch is wrong. 5. Underside of mower is dirty. 6. Tire pressure is not correct. 7. Blade spindle bent. 	<ol style="list-style-type: none"> 1. Sharpen the blade(s). 2. Install new cutting blade(s). 3. Level the mower side-to-side position. 4. Adjust the front-to-rear pitch. 5. Clean the underside of the mower. 6. Adjust the tire pressure. 7. Contact an Authorized Service Dealer.

Problem	Possible Cause	Corrective Action
Blades do not rotate.	<ol style="list-style-type: none"> 1. Drive belt is worn, loose or broken. 2. Drive belt is off pulley. 3. Deck belt is worn, loose or broken. 4. Deck belt is off pulley. 5. Broken or missing idler spring. 6. Electric clutch out of adjustment. 7. Clutch connector or wire damaged. 8. Damaged electric clutch. 9. Safety interlock system prevents blade rotation. 10. PTO switch is faulty. 	<ol style="list-style-type: none"> 1. Check the belt tension. 2. Install drive belt and check adjusting shafts and belt guides for correct position. 3. Install new deck belt. 4. Install deck pulley and check the idler pulley, idler arm and spring for correct position and function. 5. Replace the spring. 6. Adjust the clutch air gap. 7. Contact an Authorized Service Dealer. 8. Contact an Authorized Service Dealer. 9. Contact an Authorized Service Dealer. 10. Contact an Authorized Service Dealer.

Schematics

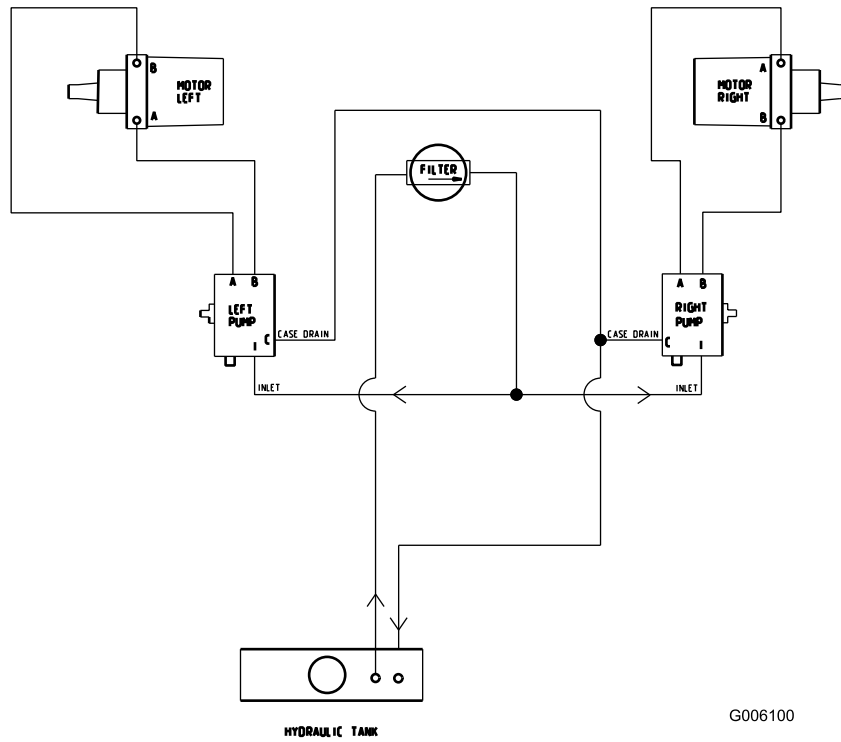

G006100

Hydraulic Schematic (Rev. A)

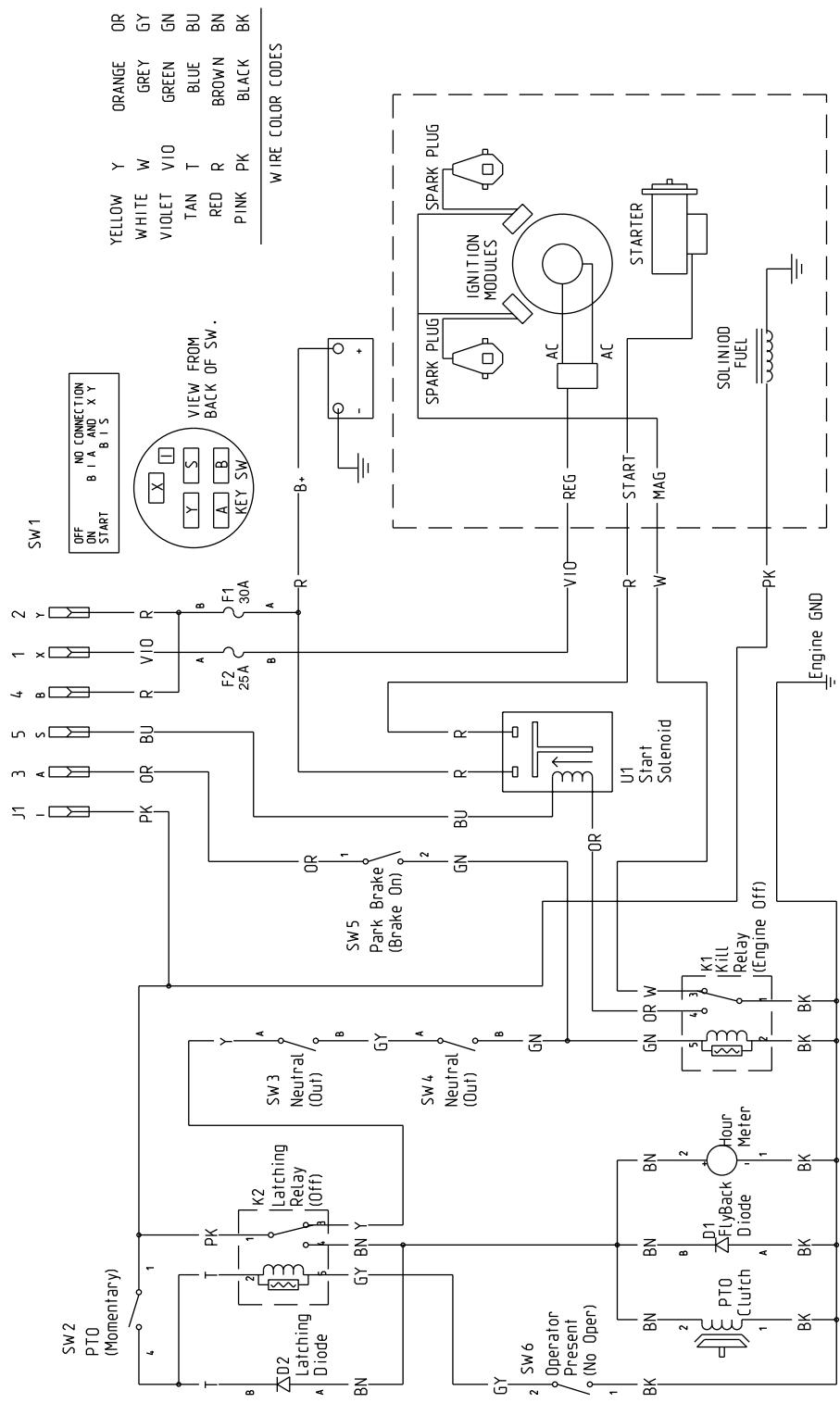

WIRE COLOR CODES	
YELLOW	Y
WHITE	W
VIOLET	V10
TAN	T
RED	R
PINK	PK
ORANGE	OR
GREY	GY
GREEN	GN
BLUE	BU
BROWN	BN
BLACK	BK

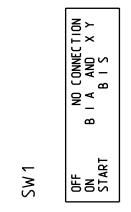

Electrical Schematic (Rev. A)

G006101



Evaporative Emission Control Warranty Statement

California Evaporative Emission Control Warranty Statement
Your Warranty Rights and Obligations

Introduction

The California Air Resources Board and The Toro® Company are pleased to explain the evaporative emission control system's warranty on your 2007 model year equipment. In California, new equipment that use small off-road engines must be designed, built, and equipped to meet the State's stringent anti-smog standards. The Toro® Company must warrant the evaporative emission control system on your equipment for two years provided there has been no abuse, neglect or improper maintenance of your equipment.

Your evaporative emission control system may include parts such as: fuel lines, fuel line fittings, and clamps.

Manufacturer's Warranty Coverage:

This evaporative emission control system is warranted for two years. If any evaporative emission-related part on your equipment is defective, the part will be repaired or replaced by The Toro® Company.

Owner's Warranty Responsibilities:

- As the equipment owner, you are responsible for performance of the required maintenance listed in your Operator's Manual. The Toro® Company recommends that you retain all receipts covering maintenance on your equipment, but The Toro® Company cannot deny warranty solely for the lack of receipts.
- As the equipment owner, you should however be aware that The Toro® Company may deny you warranty coverage if your emission warranty parts have failed due to abuse, neglect, or improper maintenance or unapproved modifications.
- You are responsible for presenting your equipment to an Authorized Service Dealer as soon as the problem exists. The warranty repairs should be completed in a reasonable amount of time, not to exceed 30 days. If you have a question regarding your warranty coverage, you should contact The Toro® Company at 1-952-948-4027 or call us toll free at the number listed in your Toro Warranty statement.

Defects Warranty Requirements:

1. The warranty period begins on the date the engine or equipment is delivered to an ultimate purchaser.
2. General Evaporative Emissions Warranty Coverage. The emission warranty parts must be warranted to the ultimate purchaser and any subsequent owner that the evaporative emission control system when installed was:
 - A. Designed, built, and equipped so as to conform with all applicable regulations; and
 - B. Free from defects in materials and workmanship that causes the failure of a warranted part for a period of two years.
3. The warranty on evaporative emissions-related parts will be interpreted as follows:
 - A. Any warranted part that is not scheduled for replacement as required maintenance in the written instructions must be warranted for the warranty period of two years. If any such part fails during the period of warranty coverage, it must be repaired or replaced by The Toro® Company. Any such part repaired or replaced under the warranty must be warranted for a time not less than the remaining warranty period.
 - B. Any warranted part that is scheduled only for regular inspection in the written instructions must be warranted for the warranty period of two years. A statement in such written instructions to the effect of "repair or replace as necessary" will not reduce the period of warranty coverage. Any such part repaired or replaced under warranty must be warranted for a time not less than the remaining warranty period.
 - C. Any warranted part that is scheduled for replacement as required maintenance in the written instructions must be warranted for the period of time prior to the first scheduled replacement point for that part. If the part fails prior to the first scheduled replacement, the part must be repaired or replaced by The Toro® Company. Any such part repaired or replaced under warranty must be warranted for a time not less than the remainder of the period prior to the first scheduled replacement point for the part.
 - D. Repair or replacement of any warranted part under the warranty provisions of this article must be performed at no charge to the owner at an Authorized Service Dealer.
 - E. Notwithstanding the provisions of subsection (D) above, warranty services or repairs must be provided at an Authorized Service Dealer.
 - F. The owner must not be charged for diagnostic labor that leads to the determination that a warranted part is in fact defective, provided that such diagnostic work is performed at an Authorized Service Dealer.
 - G. Throughout the evaporative emission control system's two year warranty period, The Toro® Company must maintain a supply of warranted parts sufficient to meet the expected demand for such parts.
 - H. Manufacturer approved replacement parts must be used in the performance of any warranty maintenance or repairs and must be provided without charge to the owner. Such use will not reduce the warranty obligations of The Toro® Company.
 - I. The use of any add-on or modified parts will be grounds for disallowing a warranty claim made in accordance with this article. The Toro® Company will not be liable under this Article to warrant failures of warranted parts caused by the use of an add-on or modified part.
 - J. The Toro® Company shall provide any documents that describe the warranty procedures or policies within five working days of request by the Air Resources Board.

Emission Warranty Parts List:

The following lists includes the parts covered under this warranty:

- Fuel Lines
- Fuel Line Fittings
- Clamps



Landscape
Contractor
Equipment (LCE)

The Toro Total Coverage Guarantee

A Limited Warranty

Conditions and Products Covered

The Toro® Company and its affiliate, Toro Warranty Company, pursuant to an agreement between them, jointly promise to repair the listed Toro Products if defective in materials or workmanship. The following time periods apply from the date of purchase:

This warranty applies to:

- ProLine Mid-Size Mowers and Attachments 1 year
- Z Master Mid-Mount ZRTs and Attachments 1 year

Components	Warranty Period
Traction Unit Frame and Carrier Frame	2 year
All Spindles	3 years Parts 2 years Labor
Engines* and /Hydraulic System	2 years
Deck Shells (34 ² -72 ²)	2 years
Z500 Series Electric Clutch	2 years
Remaining Components	1 year

*Some engines used on Toro LCE Products are warranted by the engine manufacturer. This warranty includes the cost of parts and labor, but you must pay transportation costs.

Instructions for Obtaining Warranty Service

If you think that your Toro Product contains a defect in materials or workmanship, follow this procedure:

1. Contact any Toro Authorized or Master Service Dealer to arrange service at their dealership. To locate a dealer convenient to you, access our website at www.Toro.com. You may also call our Toro Customer Care Department toll free at 888-865-5676 (U.S. Customers) or 888-865-5691 (Canada customers).
2. Bring the product and your proof of purchase (sales receipt) to the Service Dealer.

If for any reason you are dissatisfied with the Service Dealer's analysis or with the assistance provided, contact us at:

LCB Customer Service Department
Toro Warranty Company
8111 Lyndale Avenue South
Bloomington, MN 55420-1196

Countries Other than the United States or Canada

Customers who have purchased Toro products exported from the United States or Canada should contact their Toro Distributor (Dealer) to obtain guarantee policies for your country, province, or state. If for any reason you are dissatisfied with your Distributor's service or have difficulty obtaining guarantee information, contact the Toro importer. If all other remedies fail, you may contact us at Toro Warranty Company.

Owner Responsibilities

You must maintain your Toro Product by following the maintenance procedures described in the operator's manual. Such routine maintenance, whether performed by a dealer or by you, is at your expense.

Items and Conditions Not Covered

There is no other express warranty except for special emission system coverage on some products. This express warranty does not cover the following:

- Cost of regular maintenance service or parts, such as filters, fuel, lubricants, tune-up parts, blade sharpening, brake and clutch adjustments.
- Any product or part which has been altered or misused or required replacement or repair due to normal wear, accidents, or lack of proper maintenance.
- Repairs necessary due to improper fuel, contaminants in the fuel system, or failure to properly prepare the fuel system prior to any period of non-use over three months.
- Pickup and delivery charges.

General Conditions

All repairs covered by this warranty must be performed by an Authorized Toro Service Dealer using Toro approved replacement parts.

Neither The Toro® Company nor Toro Warranty Company is liable for indirect, incidental or consequential damages in connection with the use of the Toro Products covered by this warranty, including any cost or expense of providing substitute equipment or service during reasonable periods of malfunction or non-use pending completion of repairs under this warranty.

Some states do not allow exclusions of incidental or consequential damages, or limitations on how long an implied warranty lasts, so the above exclusions and limitations may not apply to you.

All implied warranties of merchantability (that the product is fit for ordinary use) and fitness for use (that the product is fit for a particular purpose) are limited to the duration of the express warranty.

This warranty gives you specific legal rights, and you may also have other rights which vary from state to state.