



## Rear Quick Attach System Groundsmaster® 7200 Series Mower

Model No. 30377 - 270000001 and up.

### Parts Catalog

---

#### Ordering Replacement Parts

To order replacement parts, please supply the part number, the quantity, and the description of each part desired.

#### Understanding Reference Numbers

Each identified part in an illustration has a reference number. The reference number for a part also appears in the parts list, along with other information about the part.

This catalog uses two special reference number formats, one to indicate parts in a service assembly and another to indicate the quantity of a given part in an illustration.

#### Service Assembly Reference Numbers

Parts in service assemblies have reference numbers in the form a:b. The a represents the reference number of the entire service assembly and the b represents a sequential number unique to each part within the service assembly.

For example, a wheel assembly might be identified by reference number 6, the tire by 6:1, the valve by 6:2, and the wheel by 6:3. When you order the assembly identified by reference number 6, you receive all parts identified by reference numbers 6:1, 6:2, and 6:3. However, you may also order any part individually. Reference numbers of this type appear in illustrations and in part lists.

#### Reference Numbers Indicating Quantity

In an illustration, if a reference number indicates more than one part, the reference number has the form nX y. The n represents the quantity of the part, the X is the multiplication symbol, and the y represents the reference number.

For example, in an illustration, the reference number 2X 37 means that two of the parts identified by reference number 37 are indicated.

# Contents

Description	Page	Description	Page
Rear Quick Attach System Assembly	..... 3	Hydraulic Manifold Assembly No. 112-1493	..... 6
Hydraulic Cylinder Assembly No. 110-5424	..... 5		

## Part Description Abbreviations

Part descriptions in this catalog may include the following abbreviations.

AR. ....	as required	HYD. ....	hydraulic
ASM. ....	assembly	LH. ....	left hand
BBC. ....	blade brake clutch	NI. ....	nylon insert
CARR. ....	carriage	NPTF. ....	national pipe thread fine
DEG. ....	degrees	PFH. ....	phillips flat head
EXT. ....	external	PPH. ....	phillips pan head
FH. ....	flat head	PPHTF. ....	phillips pan head thread forming
GA. ....	gauge	PRH. ....	phillips round head
HD. ....	heavy-duty	PTH. ....	phillips truss head
HF. ....	hex flange	PTO. ....	power-take-off
HH. ....	hex head	RH. ....	right hand
HHF. ....	hex head flange	ROPS. ....	roll-over protection system
HHFTF. ....	hex head flange thread forming	SFH. ....	slotted fillister head
HJ. ....	hex jam	SHH. ....	slotted hex head
HLH. ....	hex lag head	SHWH. ....	slotted hex washer head
HOC. ....	height-of-cut	SPH. ....	slotted pan head
HSBH. ....	hex socket button head	SQH. ....	square head
HSFH. ....	hex socket flat head	SRH. ....	slotted round head
HSH. ....	hex socket head	STD. ....	standard
HWH. ....	hex washer head	TAP. ....	self tapping
HWHTF. ....	hex washer head thread forming	TTH. ....	torx truss head

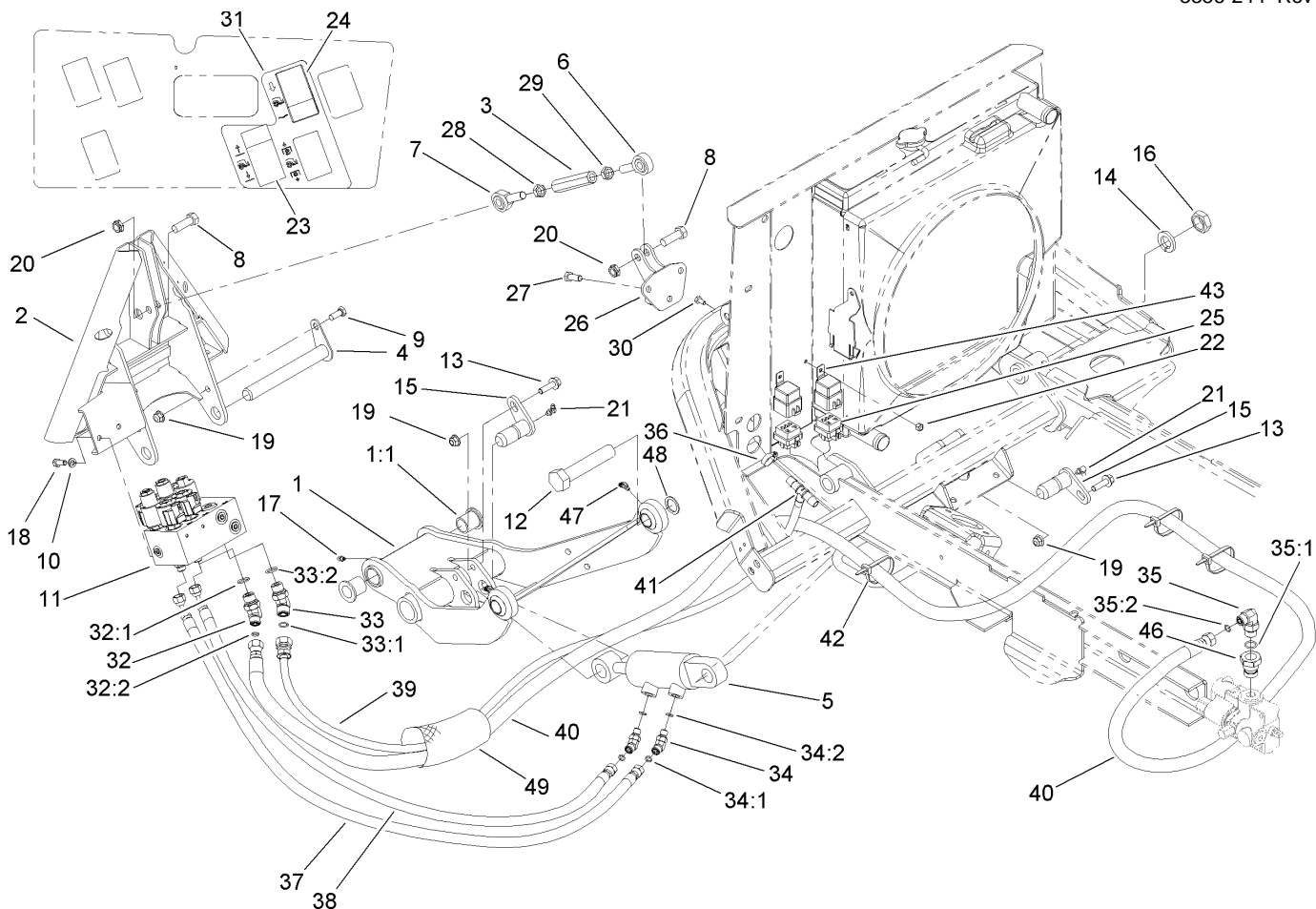

## Rear Quick Attach System Assembly

Ref	Part No.	Qty.	Description
1	110-3520-03	1	Arm-Lift, Rear
1:1	95-3577	2	Bushing
2	112-6320-03	1	Adapter ASM
3	110-5367	1	Tube-Hex
4	110-5362	1	Pin ASM
5	110-5424	1	Cylinder-Hydraulic
6	61-3540	1	Bearing-Rod End, LH
7	61-3530	1	Bearing-Rod End, RH
8	325-6	2	Screw-HH
9	323-5	1	Screw-HH
10	3253-4	2	Washer-Lock
11	112-1493	1	Hydraulic Manifold ASM
12	98-9062	2	Screw
13	3234-24	2	Screw-HHF
14	3253-28	2	Washer-Lock/Sp
15	98-2654	2	Pivot Pin ASM
16	103-8496	2	Nut-Jam
17	302-5	1	Fitting-Grease
18	322-3	2	Screw-HH
19	104-8301	6	Nut-Flange, NI
20	3296-45	2	Nut-Lock, NI
21	302-60	2	Fitting-Grease, 90 DEG
22	3296-42	2	Nut-Lock, NI
23	95-8999	1	Switch

Ref	Part No.	Qty.	Description
24	100-1535	1	Switch
25	112-3505	1	Harness-Wire, Rear Lift And Blower
26	112-6340-03	1	Link Mount ASM
27	323-6	3	Screw-HH
28	3220-5	1	Nut-Jam
29	3220-12	1	Nut-HJ (LH Thread)
30	321-2	2	Screw-HH
31	110-8268	1	Aux Decal Kit
32	340-138	1	Fitting-HYD, 45 DEG
32:1	237-79	1	O-Ring
32:2	237-22	1	O-Ring
33	340-101	1	Fitting-HYD, 45 DEG
33:1	237-30	1	O-Ring
33:2	237-79	1	O-Ring
34	340-137	2	Fitting
34:1	237-21	1	O-Ring
34:2	237-42	1	O-Ring
35	340-18	1	Fitting-HYD, 90 DEG
35:1	237-79	1	O-Ring
35:2	237-22	1	O-Ring
36	2412-36	3	Clamp-Hose
37	112-9547	1	HYD Hose ASM
38	112-9546	1	HYD Hose ASM





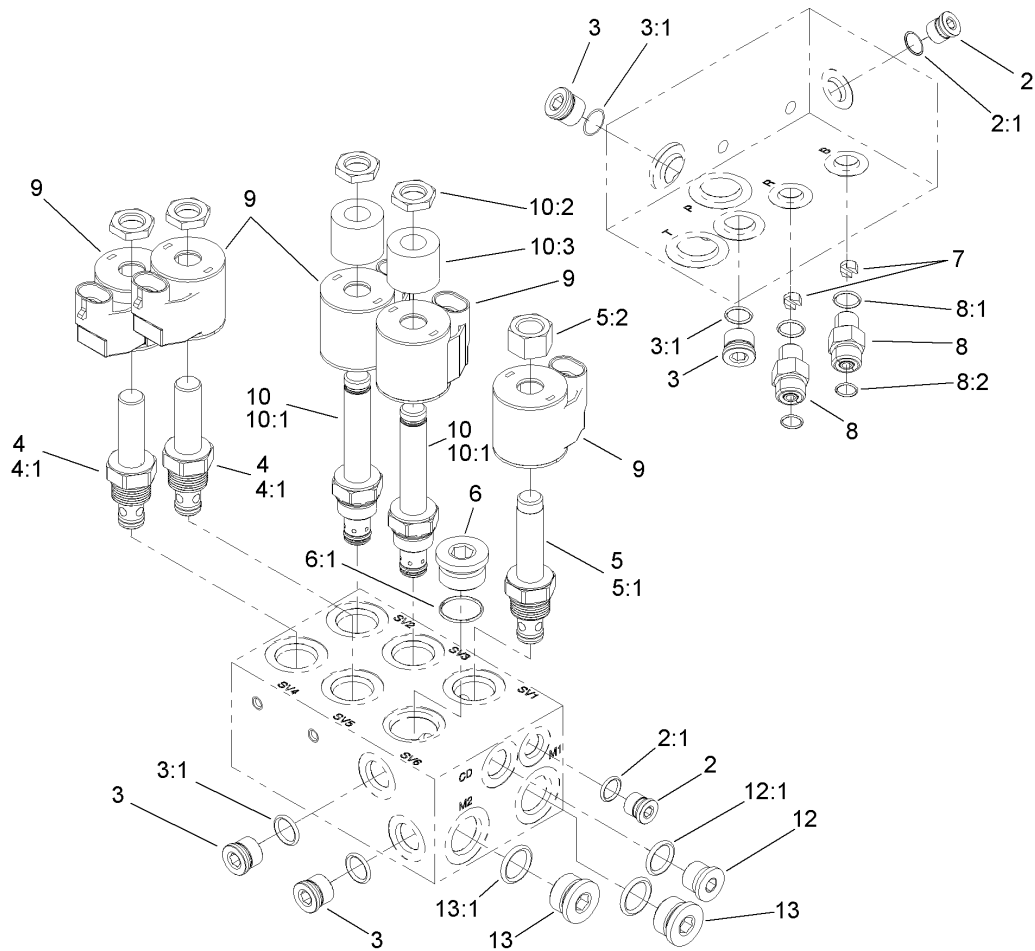

## Hydraulic Manifold Assembly No. 112-1493

Ref	Part No.	Qty.	Description
2	106-1025	2	Plug-HYD
2:1	237-78	1	O-Ring
3	106-1026	4	Plug-HYD
3:1	237-42	1	O-Ring
4	107-7516	2	Valve-Solenoid
4:1	105-9156	1	Seal Kit
5	107-7517	1	Valve-Solenoid
5:1	105-9156	1	Seal Kit
5:2	107-7812	1	Nut-Solenoid
6	353-551	1	Plug-HH
6:1	237-80	1	O-Ring
7	110-8904	2	Orifice-Control, Flow
8	340-92	2	Fitting-HYD, Straight
8:1	237-78	1	O-Ring
8:2	237-21	1	O-Ring
9	105-9333	5	Coil-12Vdc
10	110-8898	2	Valve-Solenoid
10:1	110-8907	1	Seal Kit
10:2	110-2634	1	Nut-Coil
10:3	110-8909	1	Spacer-Coil
12	353-989	1	Plug-Hex, Hollow
12:1	237-42	1	O-Ring
13	353-988	2	Plug-Hex
13:1	237-79	1	O-Ring

## NOTES

