



1/3 Area Platform Lift Workman® Heavy-Duty Utility Vehicle

Model No. 07344 - 240000001 and up.

Parts Catalog

Ordering Replacement Parts

To order replacement parts, please supply the part number, the quantity, and the description of each part desired.

Understanding Reference Numbers

Each identified part in an illustration has a reference number. The reference number for a part also appears in the parts list, along with other information about the part.

This catalog uses two special reference number formats, one to indicate parts in a service assembly and another to indicate the quantity of a given part in an illustration.

Service Assembly Reference Numbers

Parts in service assemblies have reference numbers in the form a:b. The a represents the reference number of the entire service assembly and the b represents a sequential number unique to each part within the service assembly.

For example, a wheel assembly might be identified by reference number 6, the tire by 6:1, the valve by 6:2, and the wheel by 6:3. When you order the assembly identified by reference number 6, you receive all parts identified by reference numbers 6:1, 6:2, and 6:3. However, you may also order any part individually. Reference numbers of this type appear in illustrations and in part lists.

Reference Numbers Indicating Quantity

In an illustration, if a reference number indicates more than one part, the reference number has the form nX y. The n represents the quantity of the part, the X is the multiplication symbol, and the y represents the reference number.

For example, in an illustration, the reference number 2X 37 means that two of the parts identified by reference number 37 are indicated.

Contents

Description	Page	Description	Page
Deck, Arm and Hydraulic Cylinder Assembly 3	No Step Decal and Base Assembly 5
Brake Switch Assembly 4	Power Pack Assembly 6

Part Description Abbreviations

Part descriptions in this catalog may include the following abbreviations.

AR. as required	HYD. hydraulic
ASM. assembly	LH. left hand
BBC. blade brake clutch	NI. nylon insert
CARR. carriage	NPTF. national pipe thread fine
DEG. degrees	PFH. phillips flat head
EXT. external	PPH. phillips pan head
FH. flat head	PPHTF. phillips pan head thread forming
GA. gauge	PRH. phillips round head
HD. heavy-duty	PTH. phillips truss head
HF. hex flange	PTO. power-take-off
HH. hex head	RH. right hand
HHF. hex head flange	ROPS. roll-over protection system
HHFTF. hex head flange thread forming	SFH. slotted fillister head
HJ. hex jam	SHH. slotted hex head
HLH. hex lag head	SHWH. slotted hex washer head
HOC. height-of-cut	SPH. slotted pan head
HSBH. hex socket button head	SQH. square head
HSFH. hex socket flat head	SRH. slotted round head
HSH. hex socket head	STD. standard
HWH. hex washer head	TAP. self tapping
HWHTF. hex washer head thread forming	TTH. torx truss head

Footnotes

- ❶ Not serviced separately

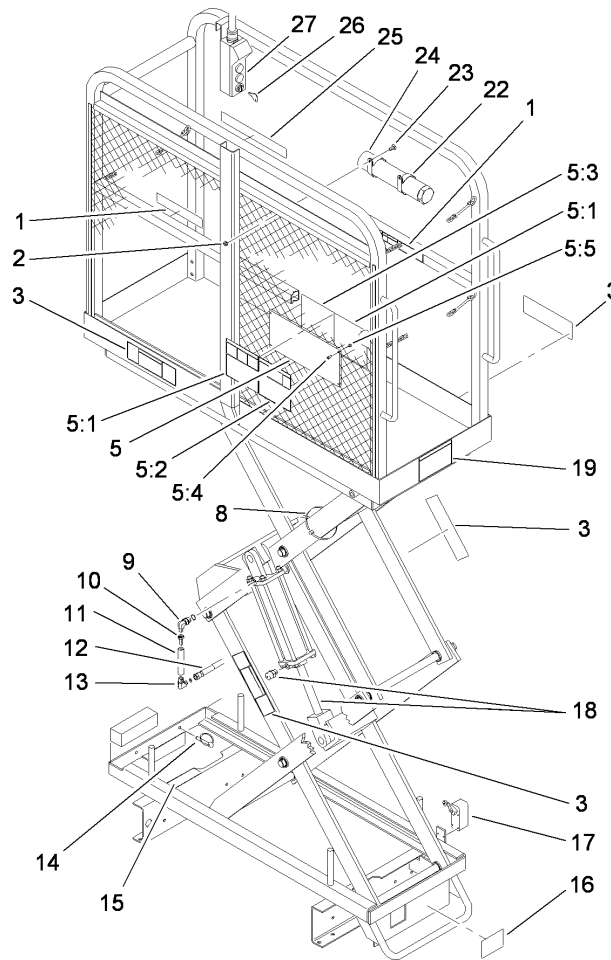

Deck, Arm and Hydraulic Cylinder Assembly

Ref	Part No.	Qty.	Description
1	93-3707	2	Decal-Danger
2	32128-20	2	Nut-HF
3	93-3706	4	Decal-Danger
5	93-3738	1	Plate-Decal
5:1	93-3702	2	Decal-Danger
5:2	93-3703	1	Decal-Danger
5:3	93-3704	1	Decal-Danger
5:4	3250-12	4	Screw-PPH
5:5	3296-2	4	Nut-Lock
8	250-5	12	Tie-Cable, Long
9	93-3749	1	Fitting-Adaptor
10	93-3747	1	Fitting-Reducer
11	93-3733	1	Control-Flow, Fixed
12	93-3735	1	HYD Hose ASM
13	93-3746	2	Fitting-Adaptor
14	93-3736	1	Pin-Release, Quick
15	93-3708	1	Decal-Danger
16	93-3711	1	Decal-Important
17	93-3713	1	Switch-Limit
18	93-3734	1	HYD Cylinder ASM
19	93-3701	1	Decal-Danger
22	2412-133	2	R-Clamp
23	3230-18	2	Screw-CARR
24	74-0720	1	Tube-Manual

Ref	Part No.	Qty.	Description
25	93-3705	1	Decal-Danger
26	92-9145	1	Switch-Key, Operator
27	93-3712	1	Control-Button, Push

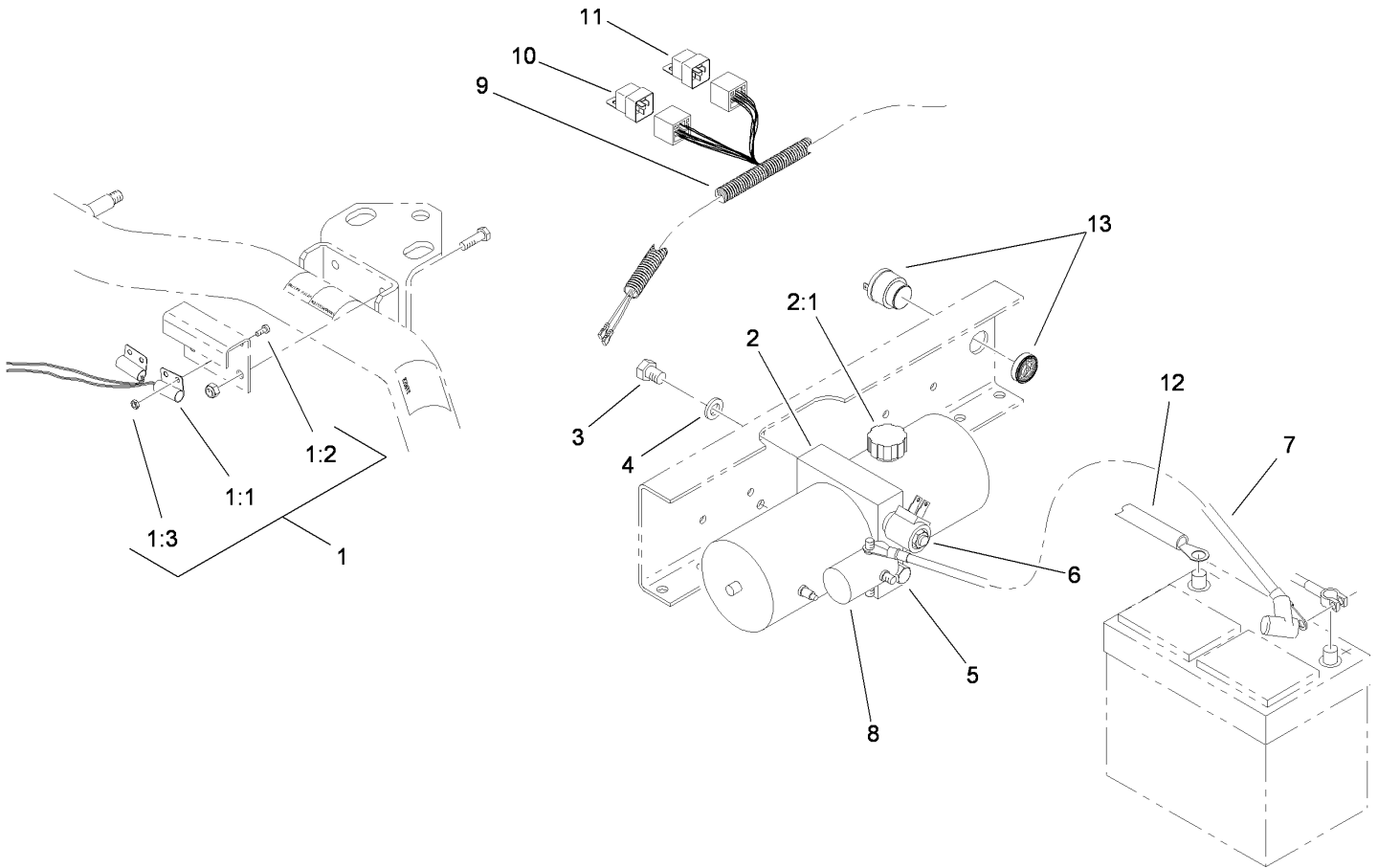

Power Pack Assembly

Ref	Part No.	Qty.	Description
1	112-3359	1	Leveling Switch Kit
1:1		2	Switch-Level
1:2	3250-12	4	Screw-PPH
1:3	3296-12	4	Nut-Lock
2	93-3732	1	Unit-Power, Dc (HYD)
2:1	98-2954	1	Cap-Reservoir
3	323-3	2	Screw-HH
4	3253-5	2	Washer-Lock
5	93-3748	1	Fitting-Adaptor
6	92-9144	1	Valve-Solenoid
7	93-3725	1	Cable-Battery
8	94-2864	1	Start Switch Relay Kit
9	93-3718	1	Wire Harness Kit (With Relays)
10	93-3721	1	Relay
11	63-7590	1	Relay
12	93-3745	1	Cable-Battery, Negative
13	93-3715	1	Sonalert-Intermittent

NOTES

