



Greensmaster® 3250-D 2-Wheel Drive Traction Unit

Model No. 04383 - 280000001 and up.

Parts Catalog

Ordering Replacement Parts

To order replacement parts, please supply the part number, the quantity, and the description of each part desired.

Understanding Reference Numbers

Each identified part in an illustration has a reference number. The reference number for a part also appears in the parts list, along with other information about the part.

This catalog uses two special reference number formats, one to indicate parts in a service assembly and another to indicate the quantity of a given part in an illustration.

Service Assembly Reference Numbers

Parts in service assemblies have reference numbers in the form a:b. The a represents the reference number of the entire service assembly and the b represents a sequential number unique to each part within the service assembly.

For example, a wheel assembly might be identified by reference number 6, the tire by 6:1, the valve by 6:2, and the wheel by 6:3. When you order the assembly identified by reference number 6, you receive all parts identified by reference numbers 6:1, 6:2, and 6:3. However, you may also order any part individually. Reference numbers of this type appear in illustrations and in part lists.

Reference Numbers Indicating Quantity

In an illustration, if a reference number indicates more than one part, the reference number has the form nX y. The n represents the quantity of the part, the X is the multiplication symbol, and the y represents the reference number.

For example, in an illustration, the reference number 2X 37 means that two of the parts identified by reference number 37 are indicated.

Contents

Description	Page	Description	Page
Traction Control Assembly 3	Hydraulic Manifold Assembly No. 112-9197 26
Brake Pedal Assembly 4	Front Bulkhead and Reel Motor Assembly 28
Front Wheel and Brake Assembly 5	Hydraulic Motor Assembly No. 112-9200 29
Brake Assembly No. 104-7705 6	Rear Bulkhead and Reel Motor Assembly 30
LH Hydraulic Wheel Motor Assembly No. 112-0237 7	Left Hand and Right Hand Lift Arm Assembly 31
RH Hydraulic Wheel Motor Assembly No. 112-0238 8	Hydraulic Cylinder Assembly No. 105-3821 32
Steering Arm Assembly 9	Center Lift Arm Assembly 33
Steering Valve Assembly No. 114-4672 10	Hydraulic Cylinder Assembly No. 105-3820 34
Rear Wheel Assembly 11	Fuel System Assembly 35
Hydraulic Cylinder Assembly No. 112-0298 12	Hydraulic Tank and Filter Assembly 36
Console Assembly 13	Miscellaneous Part Assembly 37
Functional Control Lever Assembly 14	Pull Frame Assembly 38
Seat Assembly 15	Cylinder Assembly 39
Battery and Electrical Component Assembly 16	Crankshaft Assembly 40
Hydrostat and Gear Pump Drive Assembly 17	Cylinder Head Assembly 41
Hydrostat Assembly No. 105-0494 18	Injection Assembly 42
Gear Pump Assembly No. 104-7737 19	Rocker Arm Assembly 43
Neutral System Assembly 20	Oil Pan Assembly 44
Engine Installation Assembly 21	Cover Assembly 45
Air Cleaner and Exhaust Assembly 22	Gear Housing Assembly 46
Air Cleaner Assembly No. 95-5805 23	Water Pump Assembly 47
Radiator Assembly 24	Manifold Assembly 48
Manifold Block Installation Assembly 25	Alternator and Starter Assembly 49
		Gasket Set and Valve Overhaul Kit 50
		Attachments and Accessories List 51

Part Description Abbreviations

Part descriptions in this catalog may include the following abbreviations.

AR. as required	HYD. hydraulic
ASM. assembly	LH. left hand
BBC. blade brake clutch	NI. nylon insert
CARR. carriage	NPTF. national pipe thread fine
DEG. degrees	PFH. phillips flat head
EXT. external	PPH. phillips pan head
FH. flat head	PPHTF. phillips pan head thread forming
GA. gauge	PRH. phillips round head
HD. heavy-duty	PTH. phillips truss head
HF. hex flange	PTO. power-take-off
HH. hex head	RH. right hand
HHF. hex head flange	ROPS. roll-over protection system
HHFTF. hex head flange thread forming	SFH. slotted fillister head
HJ. hex jam	SHH. slotted hex head
HLH. hex lag head	SHWH. slotted hex washer head
HOC. height-of-cut	SPH. slotted pan head
HSBH. hex socket button head	SQH. square head
HSFH. hex socket flat head	SRH. slotted round head
HSH. hex socket head	STD. standard
HWH. hex washer head	TAP. self tapping
HWHTF. hex washer head thread forming	TTH. torx truss head

Footnotes

- | | |
|--|--|
| ❶ Not illustrated | ❷ Not serviced separately |
| ❸ Included in Engine Gasket Set (Ref. No. 358) | ❹ Included in Valve Overhaul Kit (Ref. No. 1033) |

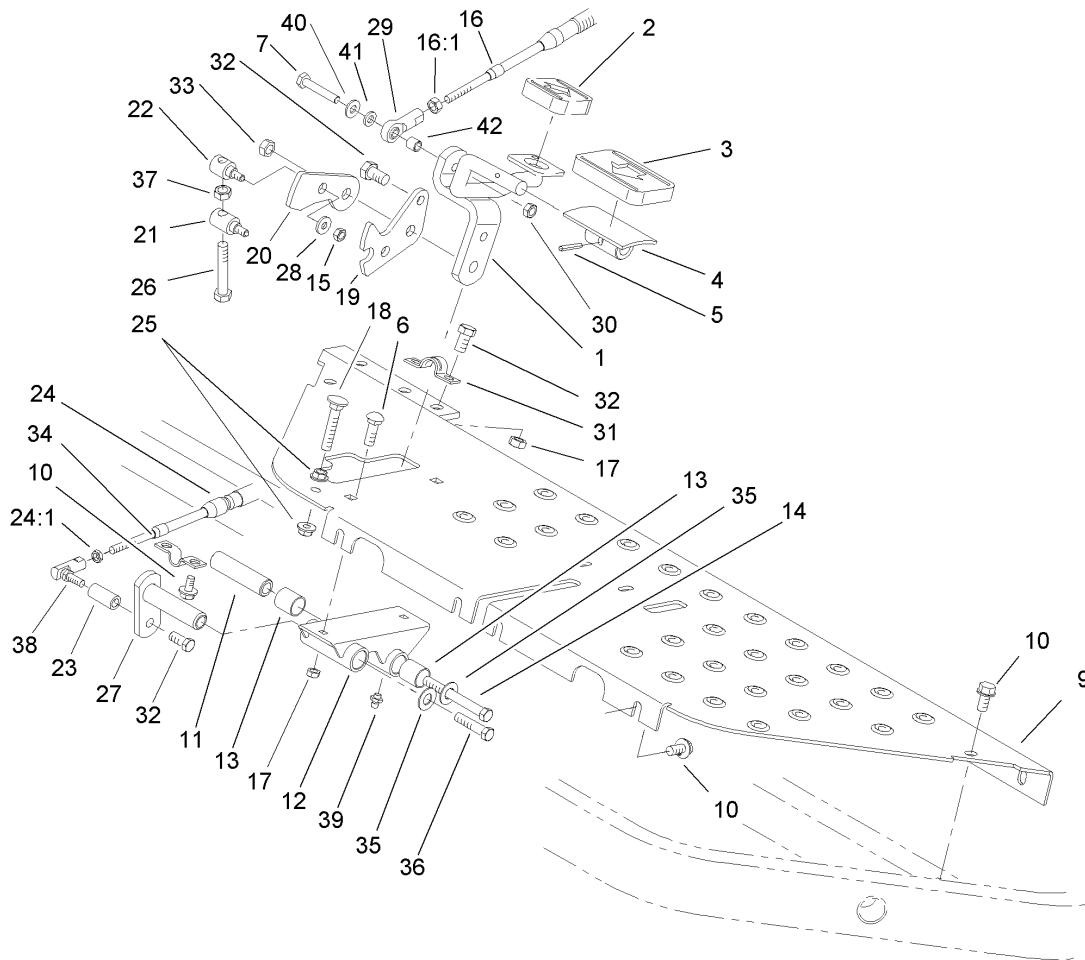

Traction Control Assembly

Ref	Part No.	Qty.	Description
1	93-2085-01	1	Rod ASM
2	74-9110	1	Pad-Pedal, Reverse
3	74-9100	1	Pad-Pedal, Forward
4	49-6440-03	1	Pedal-Forward
5	32121-45	1	Pin-Spring
6	33124-020	2	Screw-CARR
7	321-9	1	Screw-HH
9	105-9750-01	1	Plate-Floor
10	32104-32	8	Screw-HWH
11	94-1371	1	Spacer
12	94-1383	1	Pedal-Pivot
13	256-311	4	Bushing-Split
14	33115-090	1	Screw-HH
15	33023-00	2	Nut-Lock
16	107-2550	1	Cable-Control, Traction
16:1	3220-1	2	Nut-Jam
17	33024-00	4	Nut-Lock
18	17-9420	1	Screw-Handle
19	94-1373	1	Bracket-Lock
20	94-1372	1	Bracket-Mow
21	94-1375	1	Trunnion-Bracket, Lock
22	94-1374	1	Trunnion-Bracket, Mow
23	94-1386	1	Shaft-Pedal, Pivot
24	94-1304	1	Cable-Lock, Neutral

Ref	Part No.	Qty.	Description
24:1	3219-14	2	Nut-Hex
25	32128-20	2	Nut-HF
26	94-3489	1	Capscrew-HH
27	94-1300	1	Lock-Neutral
28	3256-1	2	Washer-Flat
29	2411-41	1	Joint-Ball
30	3296-56	1	Nut-Lock, NI
31	93-2092	1	Clamp-Cable
32	33114-016	4	Screw-HH
33	33025-00	1	Nut-Lock
34	93-2279	1	Clamp-Cable
35	3256-24	2	Washer-Flat
36	33115-016	1	Screw-HH
37	33014-00	1	Nut-Hex
38	2411-38	1	Joint-Ball
39	302-5	1	Fitting-Grease
40	3256-22	1	Washer-Flat
41	33093-00	1	Washer-Flat
42	99-3545	1	Spacer

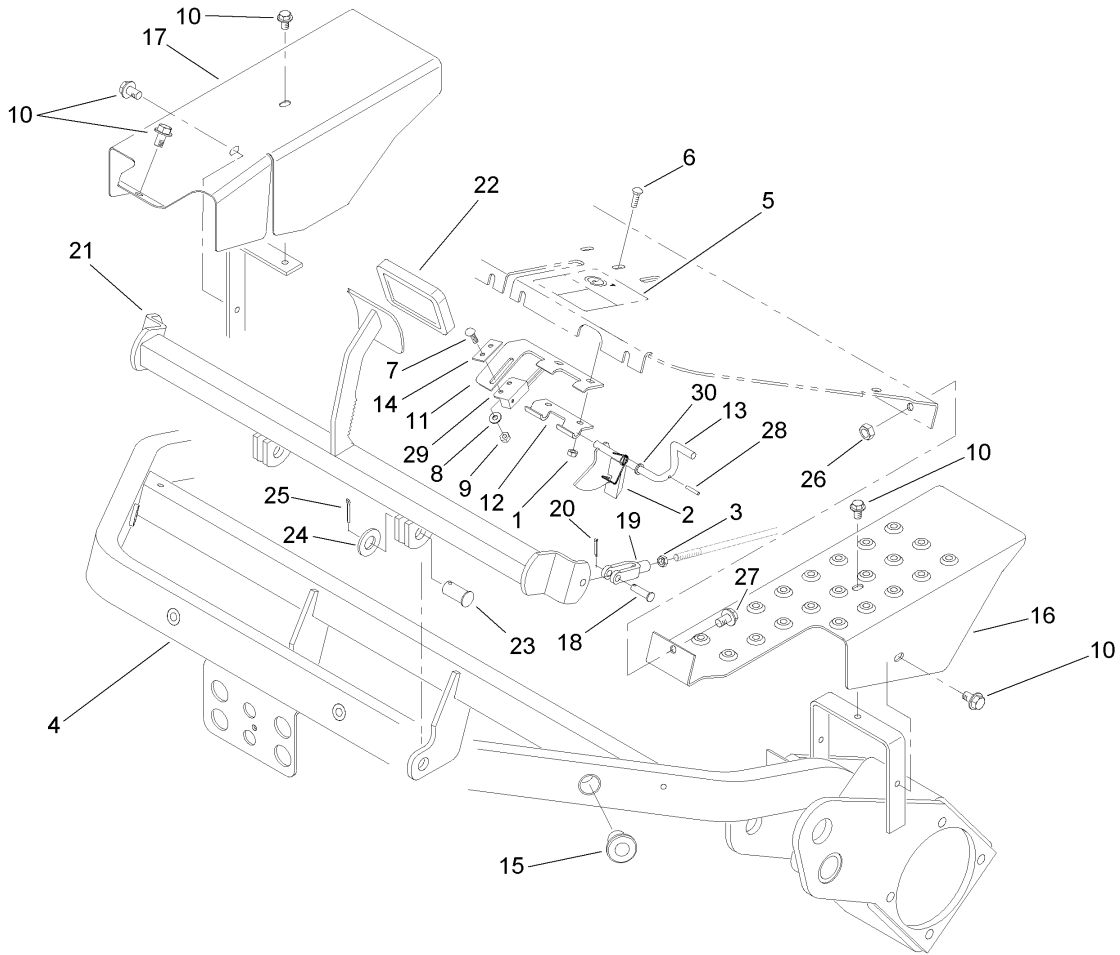

Brake Pedal Assembly

Ref	Part No.	Qty.	Description
1	33023-00	2	Nut-Lock
2	104-7704	1	Spring-Latch, Brake
3	3220-2	2	Nut-Jam
4	107-9543-01	1	Frame ASM
5	93-8062	1	Decal-Brake, Parking
6	33123-016	2	Screw-CARR
7	33123-016	1	Screw-CARR
8	33093-00	1	Washer-Flat
9	33023-00	1	Nut-Lock
10	32104-32	5	Screw-HWH
11	104-2096	1	Bracket-Switch
12	104-7703	1	Hinge-Lower
13	104-2094	1	Brake-Latch
14	104-7702	1	Plate-Switch
15	83-1700	3	Bushing-Flange
16	93-2073-01	1	Shield-Wheel, LH
17	93-2072-01	1	Shield-Wheel, RH
18	283-61	2	Pin-Yoke
19	282-2	2	Yoke
20	3272-6	2	Pin-Cotter
21	93-2075-01	1	Brake Pedal ASM
22	93-7629	1	Pad-Foot, Brake
23	283-87	2	Pin-Clevis
24	3256-27	2	Washer-Flat

Ref	Part No.	Qty.	Description
25	3272-11	2	Pin-Cotter
26	33024-00	1	Nut-Lock
27	33114-020	1	Screw-HH
28	32121-50	1	Pin-Spring
29	104-2057	1	Sensor
30	75-5470	1	Spacer-Bearing

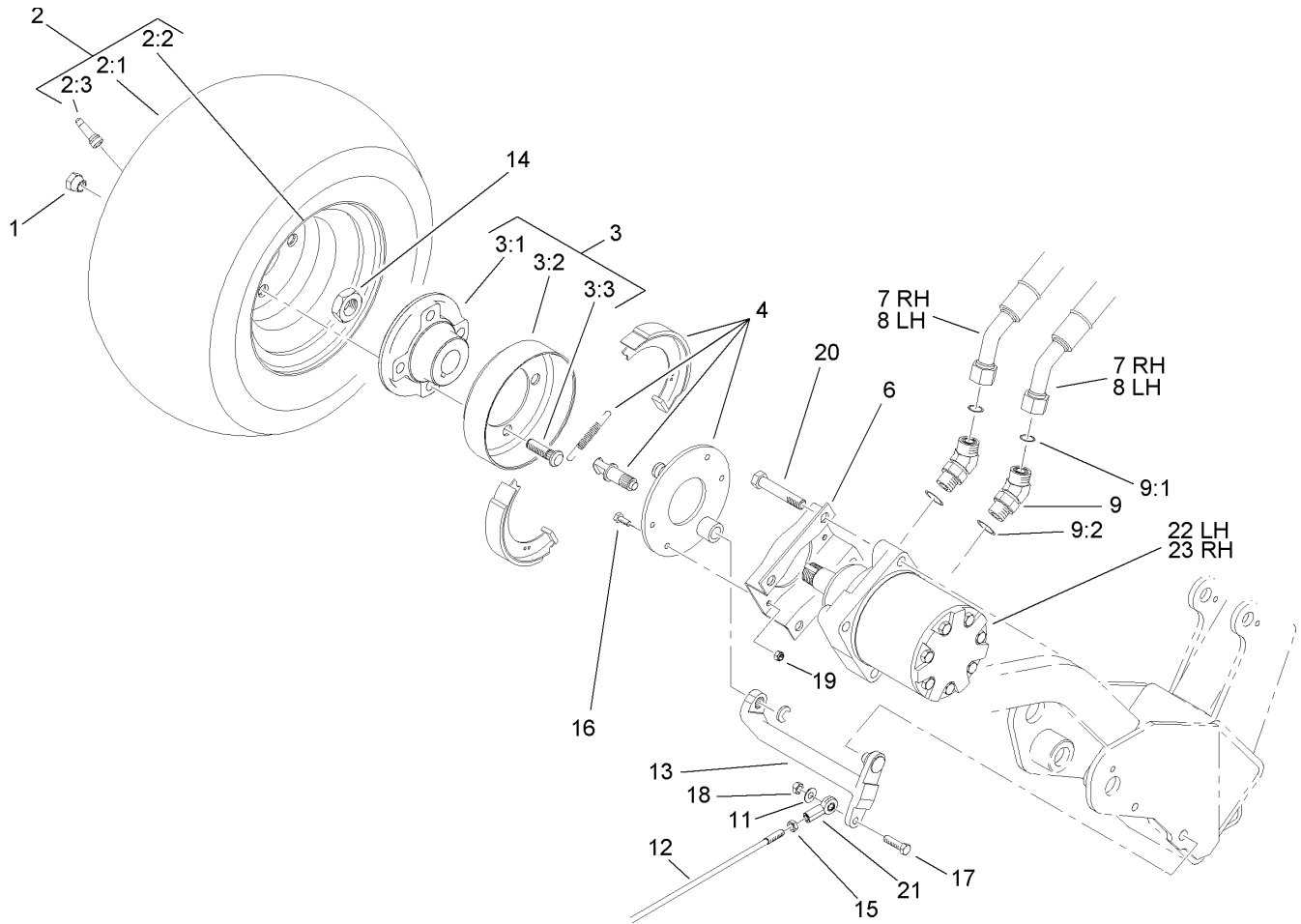

Front Wheel and Brake Assembly

Ref	Part No.	Qty.	Description
1	242-50	8	Nut-Lug
2		2	Tire ASM
2:1	70-8500	1	Tire-Smooth, 2-Ply
2:2	114-4643	1	Wheel
2:3	232-27	1	Stem-Valve
3	112-0229	2	Brake Drum ASM
3:1	108-2103-03	1	Hub-Wheel
3:2	10-6850	1	Drum-Brake
3:3	85-6540	4	Stud-Drive
4	104-7705	2	Brake ASM
6	84-2000-03	2	Bracket-Brake
7	94-5357	2	Hose ASM
8	94-5358	2	Hose ASM
9	340-14	4	Fitting-HYD, 45 DEG
9:1	237-65	1	O-Ring
9:2	237-80	1	O-Ring
11	3256-23	2	Washer-Flat
12	93-2069	2	Rod-Brake
13	93-2096	2	Lever-Brake
14	26-3790	2	Nut-Lock
15	3220-20	2	Nut-Jam
16	33113-020	8	Screw-HH
17	33114-030	2	Screw-HH
18	33024-00	2	Nut-Lock

Ref	Part No.	Qty.	Description
19	33023-00	8	Nut-Lock
20	33116-060	8	Screw-HH
21	93-2070	2	Clevis-Swivel
22	112-0237	1	Motor-Wheel, HYD (LH)
23	112-0238	1	Motor-Wheel, HYD (RH)

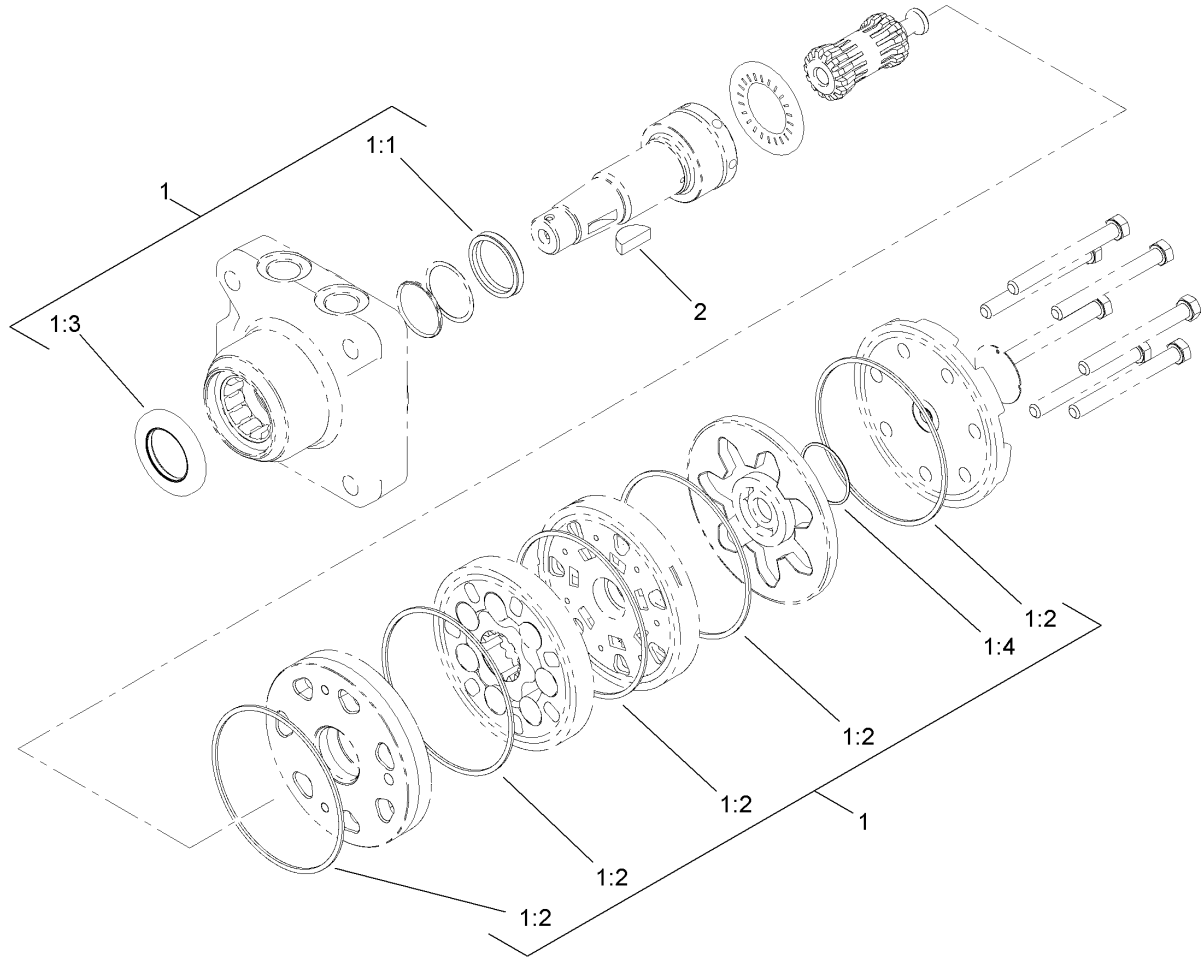

RH Hydraulic Wheel Motor Assembly No. 112-0238

Ref	Part No.	Qty.	Description
1	110-6459	1	Seal Kit
②1:1		1	Seal-Shaft
②1:2		5	Seal-Body
②1:3		1	Seal-Dirt / Water
②1:4		1	Seal-Commutator
2	3257-42	1	Key-Woodruff

Ref	Part No.	Qty.	Description

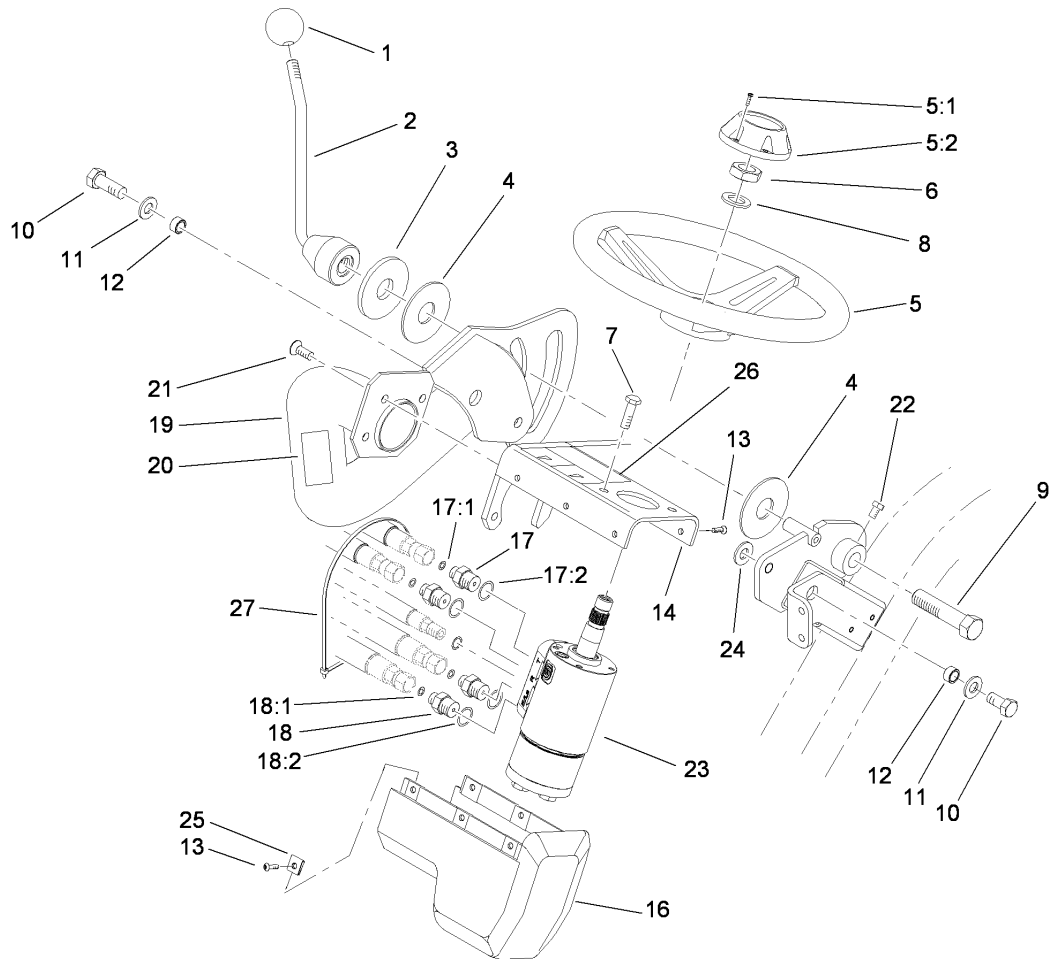

Steering Arm Assembly

Ref	Part No.	Qty.	Description	Ref	Part No.	Qty.	Description
1	233-48	1	Knob	20	93-8068	1	Decal-Arm, Steering
2	93-2400-03	1	Lockup Handle ASM	21	3274-80	3	Screw-HH
3	83-0760	1	Spacer-Plate, Lockup	22	3242-2	1	Screw-SQH
4	83-0740	2	Disc-Friction	23	114-4672	1	Valve-Steering
5	75-0560	1	Wheel-Steering	24	65-6390	1	Washer-Thrust, Plain
5:1	32144-21	1	Screw	25	3290-277	6	Nut-Speed
5:2	68-5140	1	Cap-Wheel, Steering	26	104-2053	1	Decal-Warning
6	110-8816	1	Nut-Hex	26	93-8063	1	Decal-Caution, Ce
7	33103-016	4	Screw-HHF	27	3290-379	1	Tie-Cable
8	3256-27	1	Washer-Flat				
9	93-2199	1	Screw-HH, RH				
10	325-4	2	Screw-HH				
11	3256-26	2	Washer-Flat				
12	47-2890	2	Bushing				
13	3274-39	6	Screw-HSBH				
14	114-4698-03	1	Steering Mount ASM				
16	83-0810	1	Cover-Steering				
17	340-1	1	Adapter				
17:1	237-21	1	O-Ring				
17:2	237-42	1	O-Ring				
18	340-2	2	Fitting-HYD, Straight				
18:1	237-22	1	O-Ring				
18:2	237-42	1	O-Ring				
19	93-2115-01	1	Steering Arm ASM				

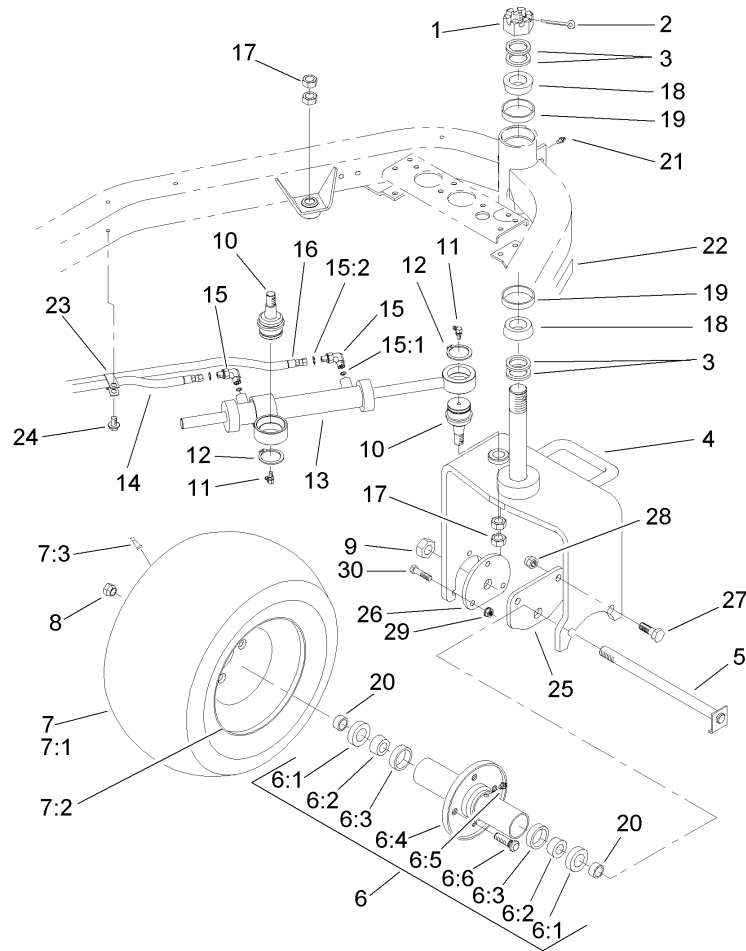

Rear Wheel Assembly

Ref	Part No.	Qty.	Description	Ref	Part No.	Qty.	Description
1	32136-9	1	Nut-Hex, Slotted	15:1	237-78	1	O-Ring
2	3272-37	1	Pin-Cotter	15:2	237-21	1	O-Ring
3	18-6320	4	Washer-Steering	16	93-2269	1	HYD Hose ASM
4	112-9174-01	1	Fork-Castor	17	3220-6	4	Nut-Jam
5	70-8370	1	Bolt	18	254-70	2	Bearing-Cone
6	72-9710	1	Hub-Tire	19	254-61	2	Cup-Bearing
6:1	253-111	2	Seal-Oil	20	70-8490	2	Spacer-Spindle, Rear
6:2	254-78	2	Bearing-Cone	21	302-5	1	Fitting-Grease
6:3	254-79	2	Bearing-Roller, Cup	22	99-1493	1	Decal
6:4	75-9440	1	Hub ASM	23	92-5753	1	Clamp-Hose
6:5	302-11	1	Fitting-Lube, 45 DEG	24	32104-32	1	Screw-HWH
6:6	10-6830	4	Stud-Type, Drive	25	99-1485-01	1	Plate-Adapter, Motor
7		1	Tire ASM	26	99-1486-01	1	Plate-Adapter
7:1	70-8500	1	Tire-Smooth, 2-Ply	27	325-6	2	Screw-HH
7:2	114-4643	1	Wheel	28	3296-23	2	Nut-Lock, NI
7:3	232-27	1	Stem-Valve	29	3296-39	3	Nut-Lock, NI
8	242-50	4	Nut-Lug	30	114-4681	3	Bolt-HHF
9	3296-67	1	Nut-Lock NI				
10	106-6774	2	Joint-Ball				
11	302-60	2	Fitting-Grease, 90 DEG				
12	32151-104	2	Ring-Retaining, External				
13	112-0298	1	Cylinder-Steering				
14	93-2270	1	HYD Hose ASM				
15	340-132	2	Fitting-HYD, 90 DEG				

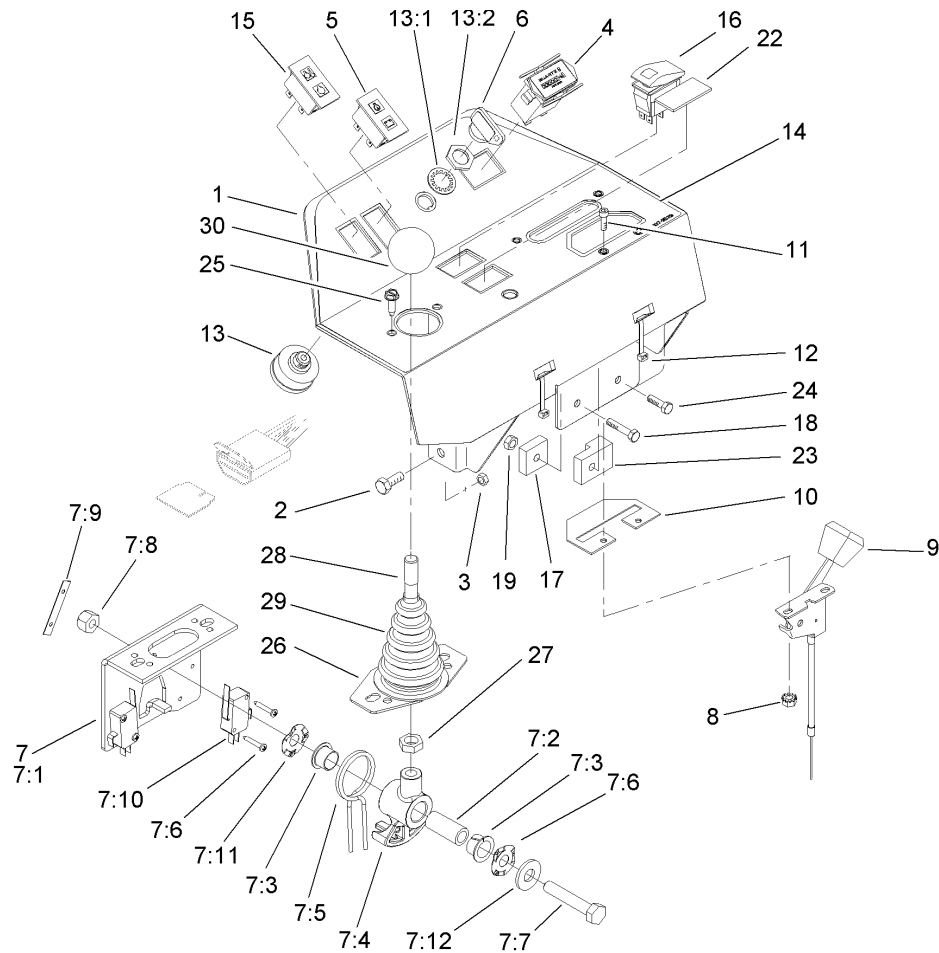

Console Assembly

Ref	Part No.	Qty.	Description
1	108-6503-03	1	Console ASM
2	33114-020	4	Screw-HH
3	33024-00	4	Nut-Lock
4	1-513374	1	Meter-Hour
5	100-8070	1	Lamp-Warning
6	63-8360	2	Key-Ignition
7	106-4167	1	Joystick Bracket ASM
7:1	106-4168-03	1	Bracket-Joystick
7:2	106-4192	1	Spacer
7:3	93-5547	2	Bushing-Nylon
7:4	105-7507	1	Hub-Pivot, Joystick
7:5	105-8289	1	Spring-Torsion
7:6	106-4193	2	Washer-Finger, Spring
7:7	322-9	1	Screw-HH
7:8	3296-29	1	Nut-Lock, NI
7:9	3290-354	2	Nut-Speed
7:10	108-6496	2	Switch ASM (W/Boot)
7:11	95-3003	4	Screw-HH
7:12	3256-3	1	Washer-Flat
8	32149-8	2	Nut-Keps
9	99-8150	1	Control-Throttle
10	112-9179	1	Plate-Cover
11	3273-26	2	Screw-HSH
12	3290-378	2	Tie-Cable

Ref	Part No.	Qty.	Description
13	27-2360	1	Switch
13:1	218-446	1	Nut-Hex
13:2	218-447	1	Washer-Lock
14	107-9529	1	Decal-Instrument
15	100-8071	1	Lamp-Warning
16	100-8072	1	Switch
17	92-2538	1	Module-Timer
18	33113-030	1	Screw-HH
19	33023-00	2	Nut-Lock
22	99-7420	1	Plug-Hole
23	114-4676	1	Module
24	33113-020	1	Screw-HH
25	32144-19	2	Screw-SHWH
26	112-9181	1	Plate-Boot
27	3218-3	1	Nut-Jam
28	105-8288	1	Rod-Joystick
29	93-5961	1	Boot-Lever
30	233-42	1	Knob

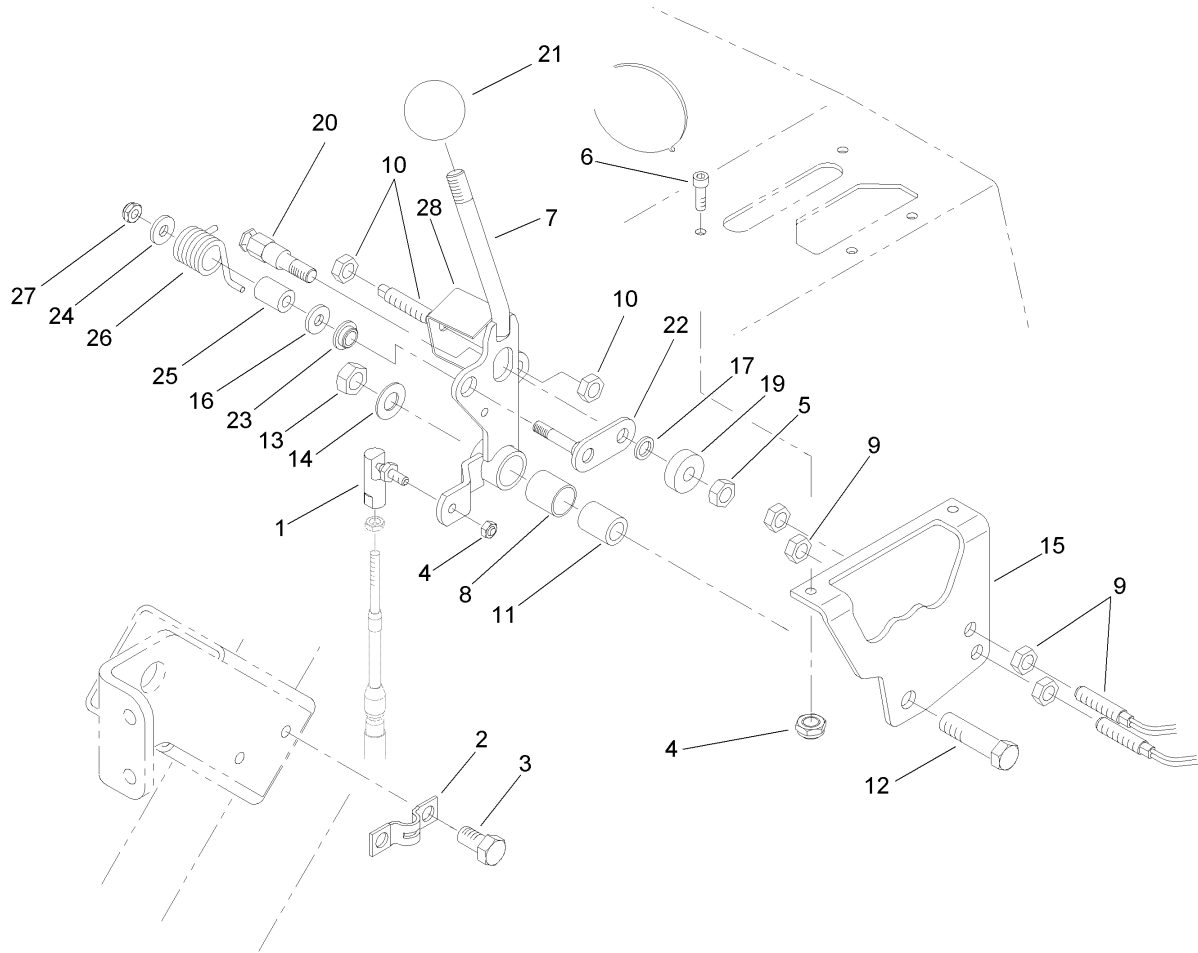

Functional Control Lever Assembly

Ref	Part No.	Qty.	Description
1	2411-38	1	Joint-Ball
2	93-2279	1	Clamp-Cable
3	32104-32	2	Screw-HWH
4	3296-27	2	Nut-Lock, NI
5	33024-00	1	Nut-Lock
6	3273-26	2	Screw-HSH
7	94-9611	1	Handle
8	256-311	1	Bushing-Split
9	112-0278	2	Switch-Reed
10	93-2056	1	Actuator-Switch, Reed
11	94-1378	1	Tube-Pivot, Handle
12	33115-040	1	Screw-HH
13	33025-00	1	Nut-Lock
14	3256-24	1	Washer-Flat
15	94-6398	1	Bracket-Traction
16	3256-23	1	Washer-Flat
17	75-5470	1	Spacer-Bearing
19	251-259	1	Bearing-Ball
20	94-9617	1	Pin-Spring
21	233-42	1	Knob
22	94-9614	1	Pivot-Roller
23	94-9619	1	Bushing
24	3256-67	1	Washer-Flat
25	94-9618	1	Spacer-Spring

Ref	Part No.	Qty.	Description
26	94-9620	1	Spring-Torsion
27	33023-00	1	Nut-Lock
28	106-6356	1	Shield-Switch

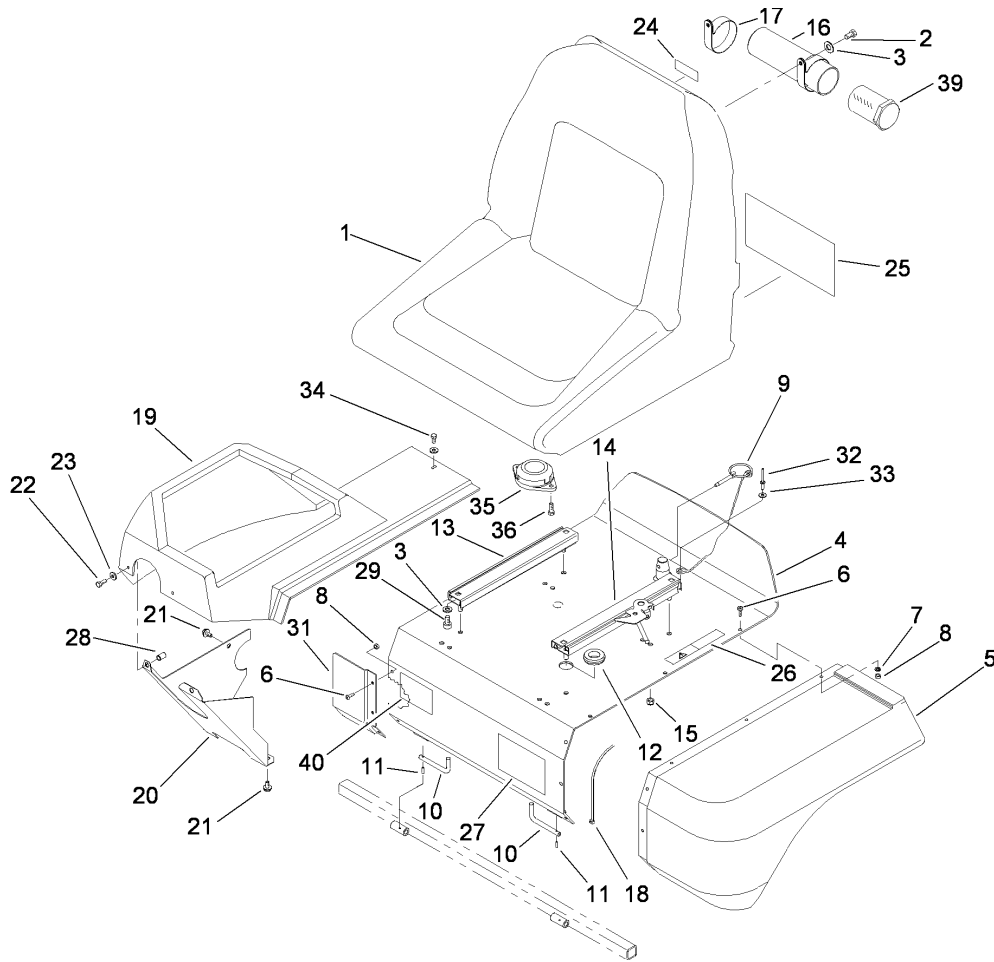

Seat Assembly

Ref	Part No.	Qty.	Description
1	104-4620	1	Seat
2	322-2	2	Screw-HH
3	3256-23	6	Washer-Flat
4	93-2135-03	1	Seat Support ASM
5	93-2128	1	Panel-Base, Seat
6	3274-39	9	Screw-HSBH
7	3256-77	6	Washer-Flat
8	3296-12	9	Nut-Lock
9	77-3780	1	Pin ASM
10	93-2422	2	Rod-Pivot, Seat
11	32121-7	2	Pin-Roll, Slotted
12	237-100	1	Grommet
13	92-8990	1	Adjuster-Slave
14	92-8991	1	Adjuster ASM (W/Latch)
15	3296-29	4	Nut-Lock, NI
16	104-7050	1	Housing-Manual
17	2412-133	2	R-Clamp
18	3290-378	1	Tie-Cable
19	99-4208	1	Shroud-Console
20	94-4547-03	1	Panel-Lower, RH
21	32104-32	2	Screw-HWH
22	33113-016	2	Screw-HH
23	3256-1	3	Washer-Flat
24	93-6686	1	Decal-Oil, HYD

Ref	Part No.	Qty.	Description
25	114-4614	1	Decal-Service
25	114-4616	1	Decal-Service, Spanish
25	114-4617	1	Decal-Service, French
25	114-4618	1	Decal-Service, German
25	114-4619	1	Decal-Service, Swedish
25	114-4620	1	Decal-Service, Italian
25	114-4621	1	Decal-Service, Portuguese
25	114-4622	1	Decal-Service, Norwegian
25	114-4623	1	Decal-Service, Finnish
25	114-4624	1	Decal-Service, Danish
25	114-4625	1	Decal-Service, Dutch
25	114-4626	1	Decal-Service, Japanese
26	93-6689	1	Decal-No Riders
27	94-2579	1	Decal
28	93-5447	2	Nut-Clinch
29	3274-12	4	Screw-HSH
31	94-4546-03	1	Panel-Extension
32	3290-282	1	Rivet-Pop
33	3256-49	1	Washer-Flat
34	33113-012	1	Screw-HH
35	92-6282	1	Switch-Seat
36	32144-10	2	Screw-HWH
39	104-7048	1	Cap-Housing
40	114-4615	1	Decal-Speed, Clip

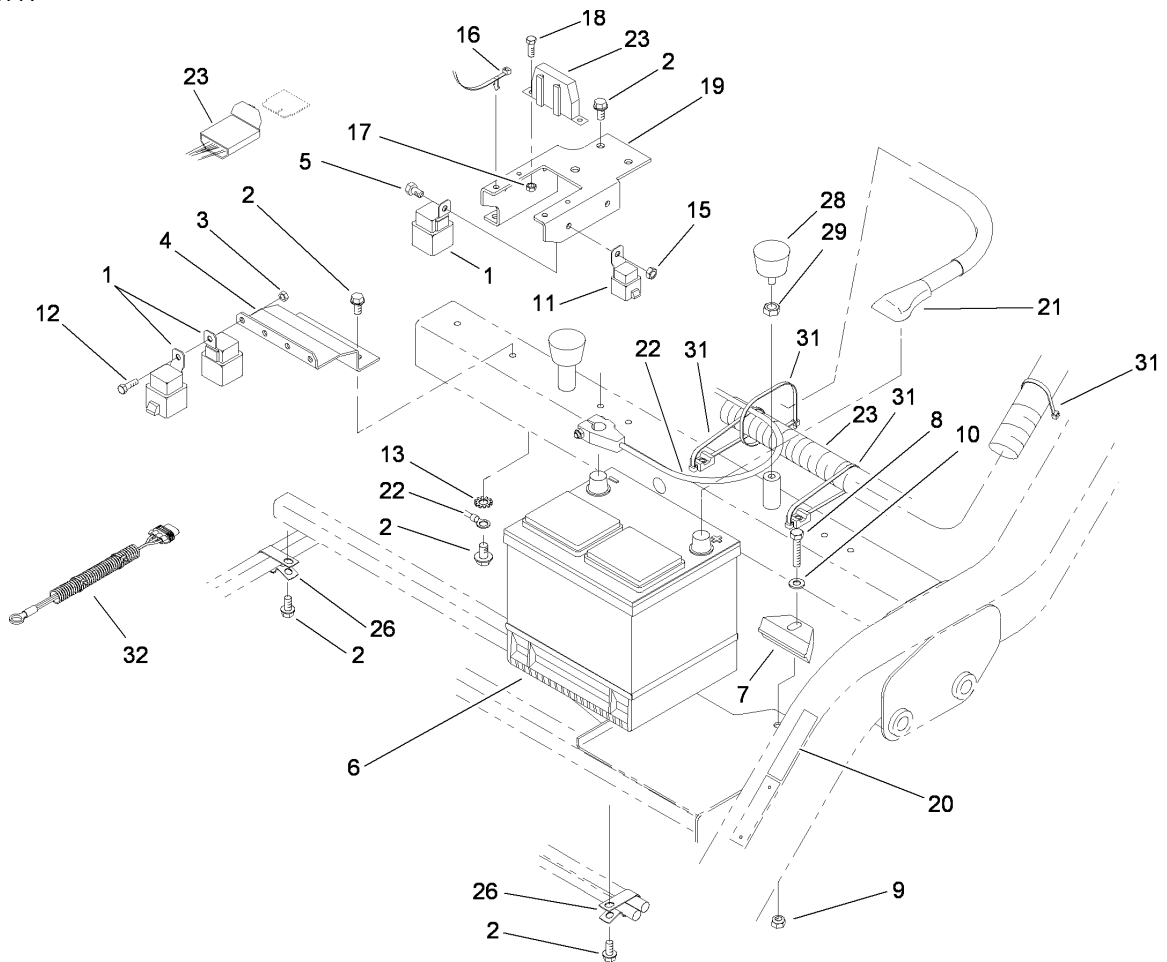

Battery and Electrical Component Assembly

Ref	Part No.	Qty.	Description
1	99-7430	9	Relay
2	32144-11	7	Screw-HWHTF
3	33023-00	4	Nut-Lock
4	93-2169-01	1	Bracket-Relay
5	3290-134	1	Screw
6	106-5187	1	Battery
7	66-2490	1	Retainer-Battery
8	33115-040	1	Screw-HH
9	33025-00	1	Nut-Lock
10	3256-24	1	Washer-Flat
11	99-7435	1	Relay-Power
12	33113-016	4	Screw-HH
13	3254-2	1	Washer-Lock, Internal
15	3296-2	1	Nut-Lock
16	94-1325	2	Tie-Mount, Push
17	32149-7	2	Nut-Keps
18	32105-13	2	Screw-HWH
19	100-3186-03	1	Bracket-Holder, Fuse
20	114-4673	1	Decal-Regulatory
21	95-8853	1	Cable-Battery, Positive
22	99-8167	1	Cable-Battery, Negative
23	112-9165	1	Harness-Wire
26	92-5753	2	Clamp-Hose
28	68-3270	2	Bumper-Rubber

Ref	Part No.	Qty.	Description
29	3218-2	2	Nut-Jam
31	3290-378	6	Tie-Cable
32	99-3441	1	Harness-Wire, Fusible Link

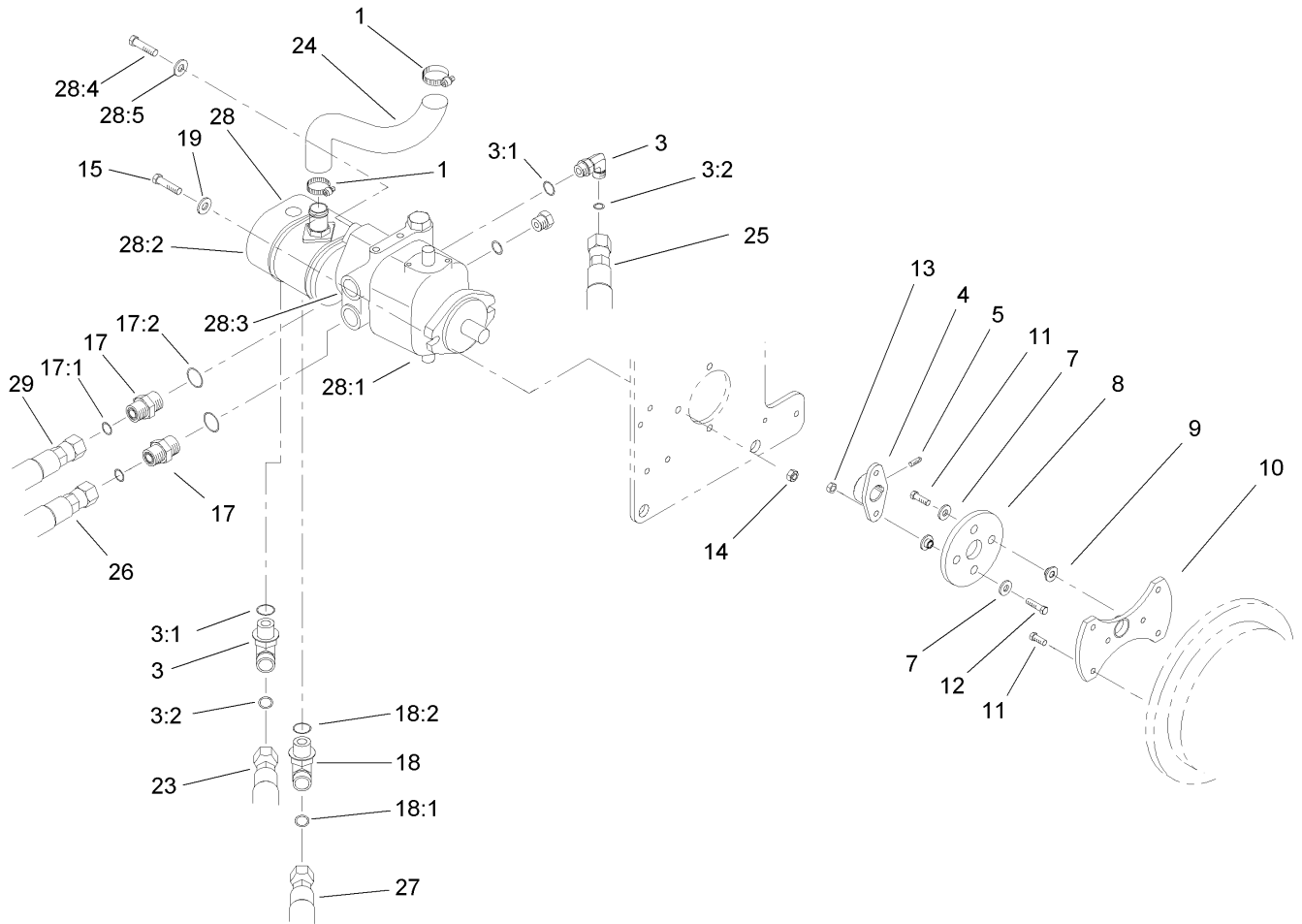

Hydrostat and Gear Pump Drive Assembly

Ref	Part No.	Qty.	Description
1	2412-34	2	Clamp-Hose
3	340-18	2	Fitting-HYD, 90 DEG
3:1	237-79	1	O-Ring
3:2	237-22	1	O-Ring
4	110-5227	1	Hub-Pump
5	3241-6	2	Screw-SQH
7	3256-3	2	Washer-Flat
8	80-8650	1	Coupling-Drive
9	27-6600	4	Spacer-Coupling
10	93-2220-03	1	Adapter-Pump
11	33114-020	6	Screw-HH
12	33114-030	1	Screw-HH
13	33024-00	2	Nut-Lock
14	33025-00	2	Nut-Lock
15	33115-040	2	Screw-HH
17	340-8	2	Adapter
17:1	237-65	1	O-Ring
17:2	237-81	1	O-Ring
18	340-17	1	Fitting-HYD, 90 DEG
18:1	237-65	1	O-Ring
18:2	237-80	1	O-Ring
19	100-4852	2	Washer-Hardened
23	105-4339	1	HYD Hose ASM
24	99-1905	1	Hose-Inlet, Pump

Ref	Part No.	Qty.	Description
25	108-6514	1	Hose ASM
26	99-4220	1	Hose ASM
27	99-4216	1	Hose ASM
28		1	Hydrostat/Gear Pump ASM
28:1	105-0494	1	Hydrostat ASM
28:2	104-7737	1	Gear Pump ASM
28:3	60-3520	1	O-Ring
28:4	3274-1	2	Screw-HSH
28:5	3256-24	2	Washer-Flat
29	99-4217	1	Hose ASM

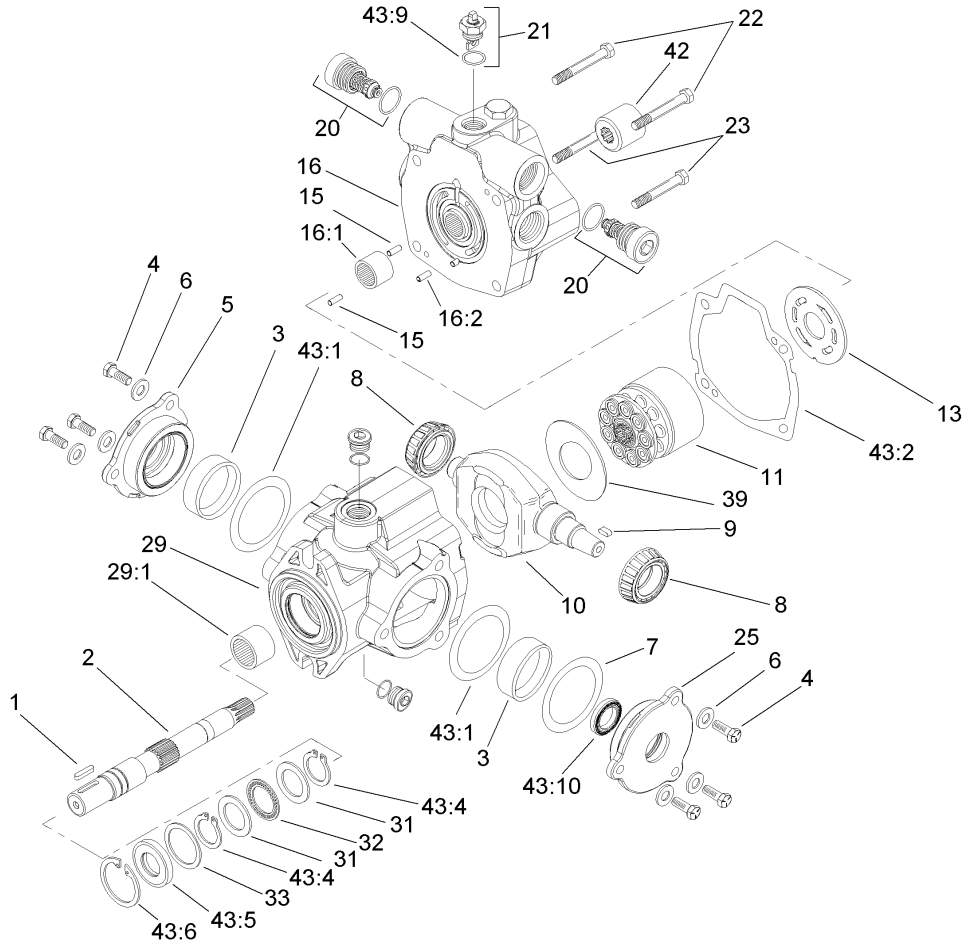

Hydrostat Assembly No. 105-0494

Ref	Part No.	Qty.	Description
1	94-3645	1	Key
2	94-6359	1	Shaft-Drive
3	104-4046	2	Bearing-Cup
4	98-4640	6	Screw-Cap
5	98-4644	1	Plate-Cover
6	105-9762	6	Washer
7	100-3182	2	Shim Kit
8	98-4639	2	Bearing-Cone
9	94-3646	1	Key
10	100-3175	1	Camplate
11	76-6070	1	Rotating Kit
13	100-3180	1	Valve-Plate
15	76-6150	2	Pin-Dowel
16	105-3813	1	Endcover Sub ASM
16:1	94-6368	1	Bearing
●16:2		1	Pin-Roll
20	105-3812	2	Valve-Check
21	105-3811	1	Valve-Bypass
22	76-6170	2	Capscrew
23	76-6160	2	Capscrew
25	98-4645	1	Plate-Cover
29	100-3176	1	Housing ASM
29:1	94-6363	1	Bearing
31	252-71	2	Washer-Thrust

Ref	Part No.	Qty.	Description
32	252-66	1	Bearing-Thrust
33	33-3720	1	Washer
39	98-4635	1	Insert-Plate, Cam
42	74-9040	1	Coupler
43	105-3844	1	Seal Repair Kit
43:1	100-3179	2	O-Ring
43:2	33-4930	1	Gasket-Housing
43:4	32151-29	2	Ring-Retaining
43:5	104-4861	1	Seal-Shaft
43:6	32151-13	1	Ring-Retaining
●43:9		1	Seal-Dust
●43:10		1	Seal-Shaft

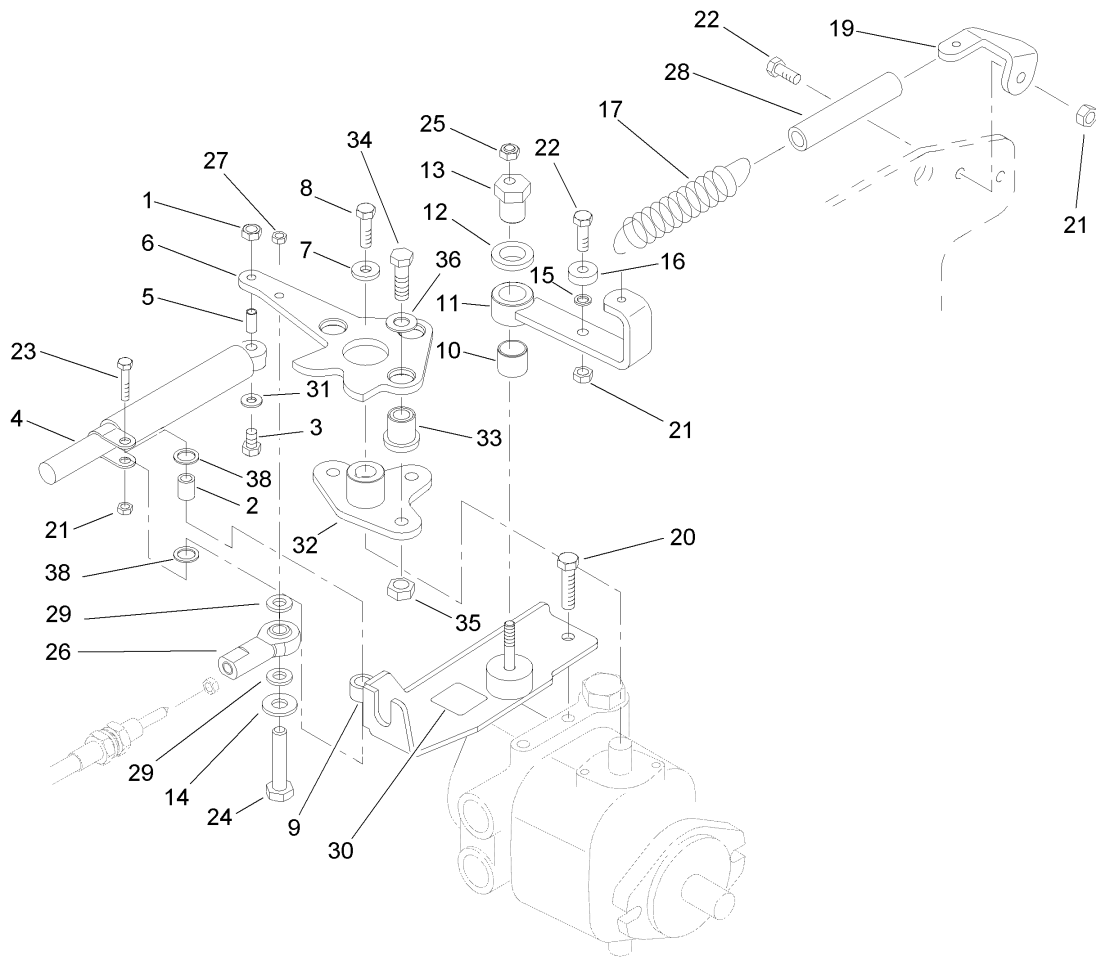

Neutral System Assembly

Ref	Part No.	Qty.	Description
1	33023-00	1	Nut-Lock
2	94-8197	1	Tube-Pivot
3	33113-035	1	Screw-HH
4	76-8870	1	Lever Damper ASM
5	94-1312	1	Spacer-Pivot
6	94-3488-03	1	Lever-Pump
7	88-7200	1	Washer-Flat
8	3210-6	1	Screw-HH
9	100-9846	1	Support-Cable
10	94-9609	1	Bushing-Straight
11	94-4527	1	Arm-Neutral
12	3-6498	1	Washer-Thrust
13	93-2111	1	Stud-Traction
14	3256-22	1	Washer-Flat
15	75-5470	1	Spacer-Bearing
16	251-259	1	Bearing-Ball
17	99-4254	1	Spring-Extension
19	99-4276	1	Bracket-Spring
20	323-4	2	Screw-HH
21	33024-00	3	Nut-Lock
22	33114-025	2	Screw-HH
23	33114-030	1	Screw-HH
24	321-8	1	Screw-HH
25	3296-29	1	Nut-Lock, NI

Ref	Part No.	Qty.	Description
26	2411-41	1	Joint-Ball
27	3296-42	1	Nut-Lock, NI
28	99-4251	1	Hose-Dampener
29	33093-00	2	Washer-Flat
30	93-9051	1	Decal-Bolt, Eccentric
31	3256-22	1	Washer-Flat
32	94-3486	1	Plate
33	63-9750	3	Mount
34	33115-035	3	Screw-HH
35	33025-00	3	Nut-Lock
36	2844	3	Washer
38	94-8196	2	Washer-Nylon

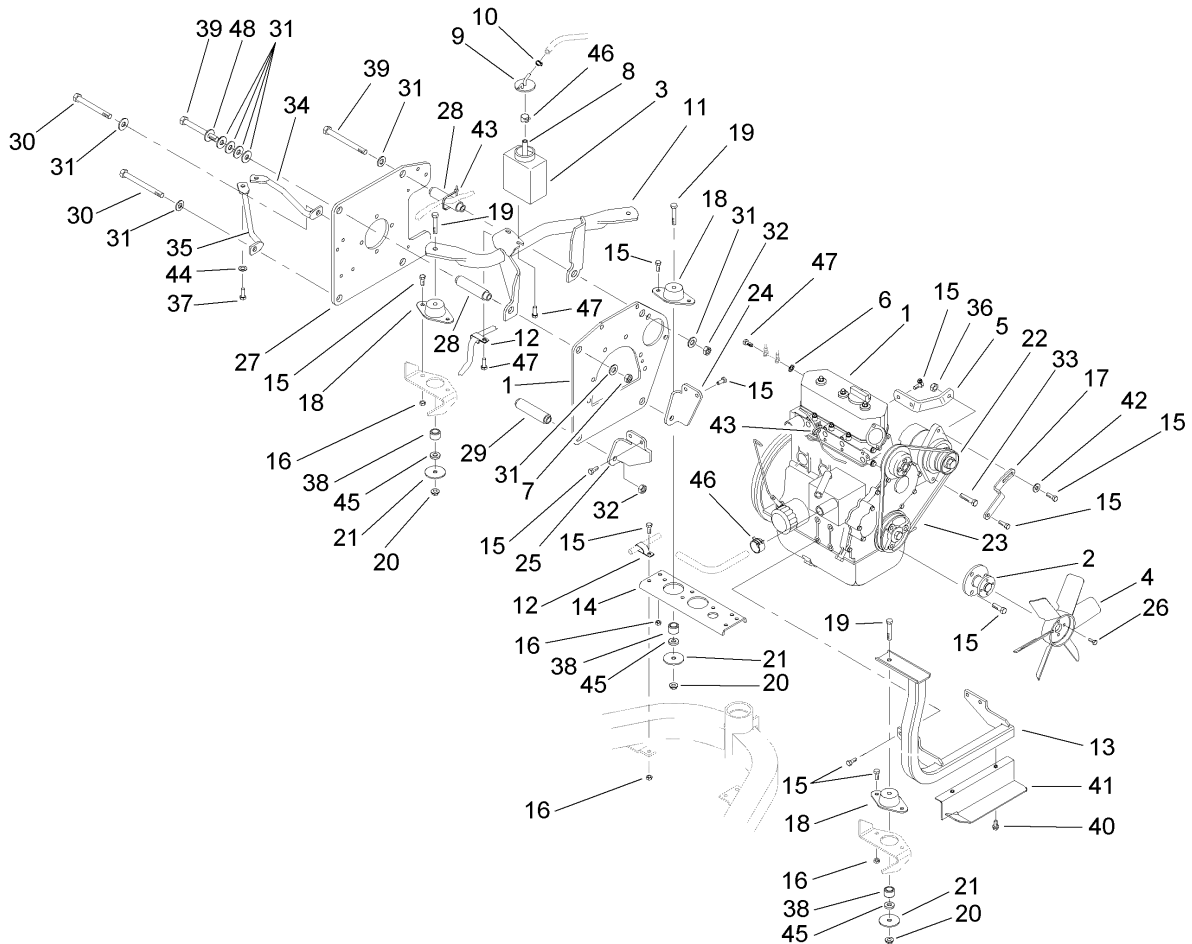

Engine Installation Assembly

Ref	Part No.	Qty.	Description
1	114-4664	1	Engine
2	99-1495	1	Adapter-Fan
3	93-2049	1	Tank-Overflow
4	93-2090	1	Fan-Engine
5	93-2445	1	Bracket-Alternator, Upper
6	3254-2	1	Washer-Lock, Internal
7	51-2070	1	Nut
8	108-3283	1	Hose-Fuel
9	93-2048	1	Cap-Tank, Overflow
10	2412-108	1	Clamp-Worm
11	100-3190-03	1	Engine Mount ASM
12	92-5753	2	Clamp-Hose
13	99-1473-03	1	Mount-Engine, Front
14	93-2020-01	1	Bracket-Support
15	33114-020	26	Screw-HH
16	33024-00	4	Nut-Lock
17	93-2446	1	Bracket-Alternator, Lower
18	83-1030	3	Mount-Engine
19	323-11	3	Screw-HH
20	3290-357	3	Nut-HHF, Whiz
21	83-1040	3	Washer-Flat
22	99-9209	1	Alternator
23	99-8153	1	Belt-V
24	99-4189-03	1	Bracket-Engine, LH

Ref	Part No.	Qty.	Description
25	99-4188-03	1	Bracket-Engine, RH
26	33113-016	4	Screw-HH
27	99-4190-03	1	Plate-Pump
28	93-2588	2	Spacer-Upper
29	93-2174	2	Spacer
30	33116-130	2	Screw-HH
31	87-7270	9	Washer-Thrust
32	33026-00	3	Nut-Lock
33	33115-050	1	Screw-HH
34	99-4240	1	Brace-Wireform, LH
35	99-4238	1	Brace-Wireform, RH
36	33025-00	1	Nut-Lock
37	323-4	2	Screw-HH
38	94-4538	3	Spacer-Mount
39	33116-120	2	Screw-HH
40	32104-32	2	Screw-HWH
41	94-8156-03	1	Deflector-Fan
42	3256-3	1	Washer-Flat
43	3290-378	2	Tie-Cable
44	3256-24	2	Washer-Flat
45	66-6480	3	Washer
46	92-2379	2	Clamp-Hose
47	33114-016	3	Screw-HH
48	73-0040	1	Washer-Thrust

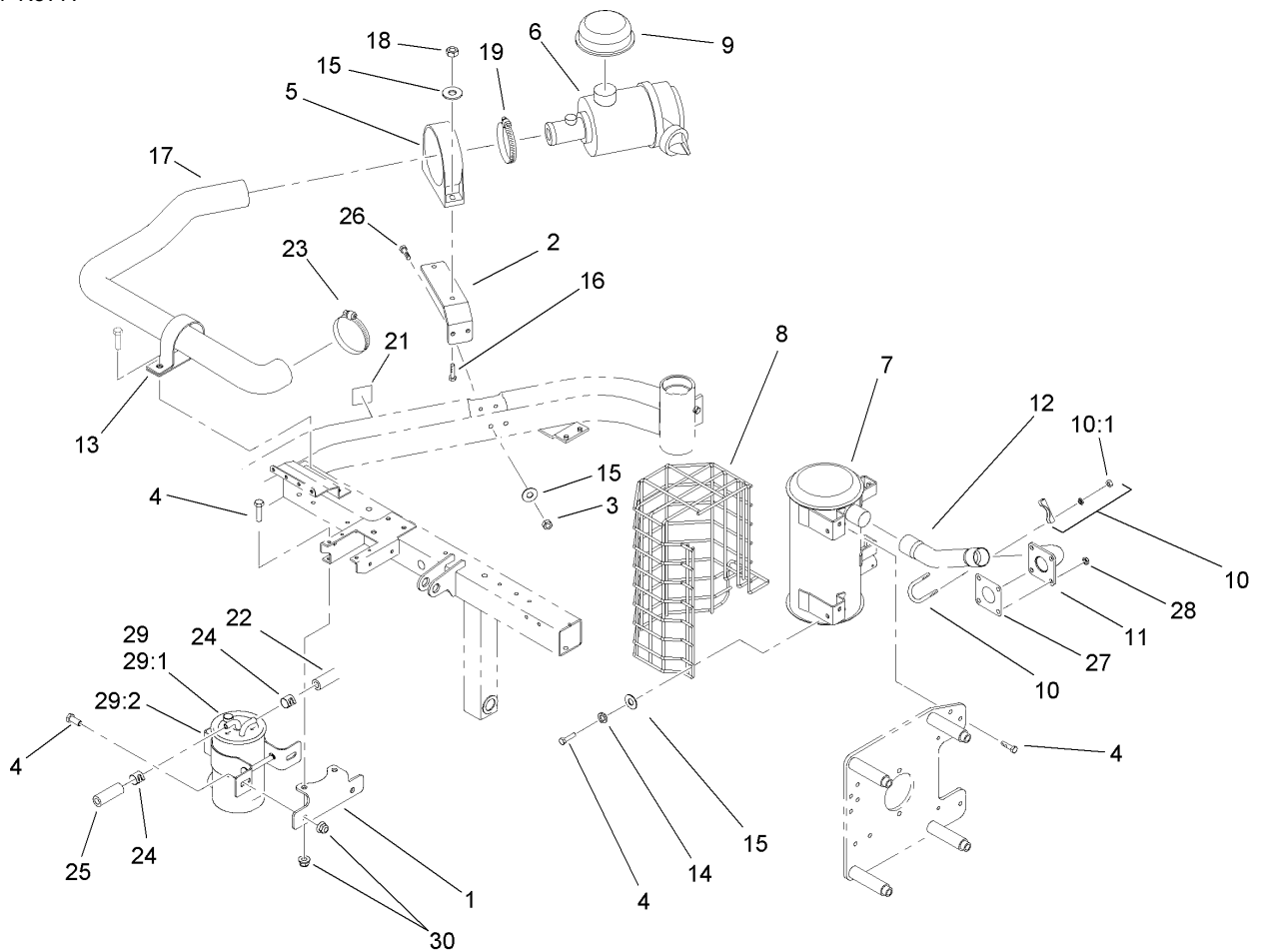

Air Cleaner and Exhaust Assembly

Ref	Part No.	Qty.	Description
1	112-9178	1	Bracket-Filter
2	99-4203-03	1	Bracket-Cleaner, Air
3	33024-00	2	Nut-Lock
4	33114-020	10	Screw-HH
5	95-5806	1	Bracket-Mounting
6	95-5805	1	Air Cleaner ASM
7	94-8153	1	Muffler
8	108-6485	1	Guard-Muffler
9	46-7510	1	Hood-Inlet, Air
10	2112-9	2	Clamp
10:1	32128-20	2	Nut-HF
11	99-1472	1	Plate-Exhaust
12	99-1494	1	Pipe-Exhaust
13	2412-107	1	Clamp-R
14	3253-4	4	Washer-Lock
15	3256-23	4	Washer-Flat
16	322-16	2	Screw-HH
17	99-4204	1	Hose-Cleaner, Air
18	3296-29	2	Nut-Lock, NI
19	2412-92	1	Clamp-Hose
21	93-7275	1	Decal-Fluid, Starting
22	110-4112	1	Hose-Fuel
23	2412-130	1	Clamp-Hose
24	92-2379	2	Clamp-Hose

Ref	Part No.	Qty.	Description
25	110-4007	1	Hose-Fuel
26	33114-080	2	Screw-HH
27	99-9179	1	Gasket-Exhaust
28	99-9176	4	Nut-Hex
29	110-8814	1	Fuel Filter ASM
29:1	112-9188	1	Element-Filter, Fuel
29:2	112-9189	1	Bracket-Filter
30	104-3082	4	Nut-Lock, HF

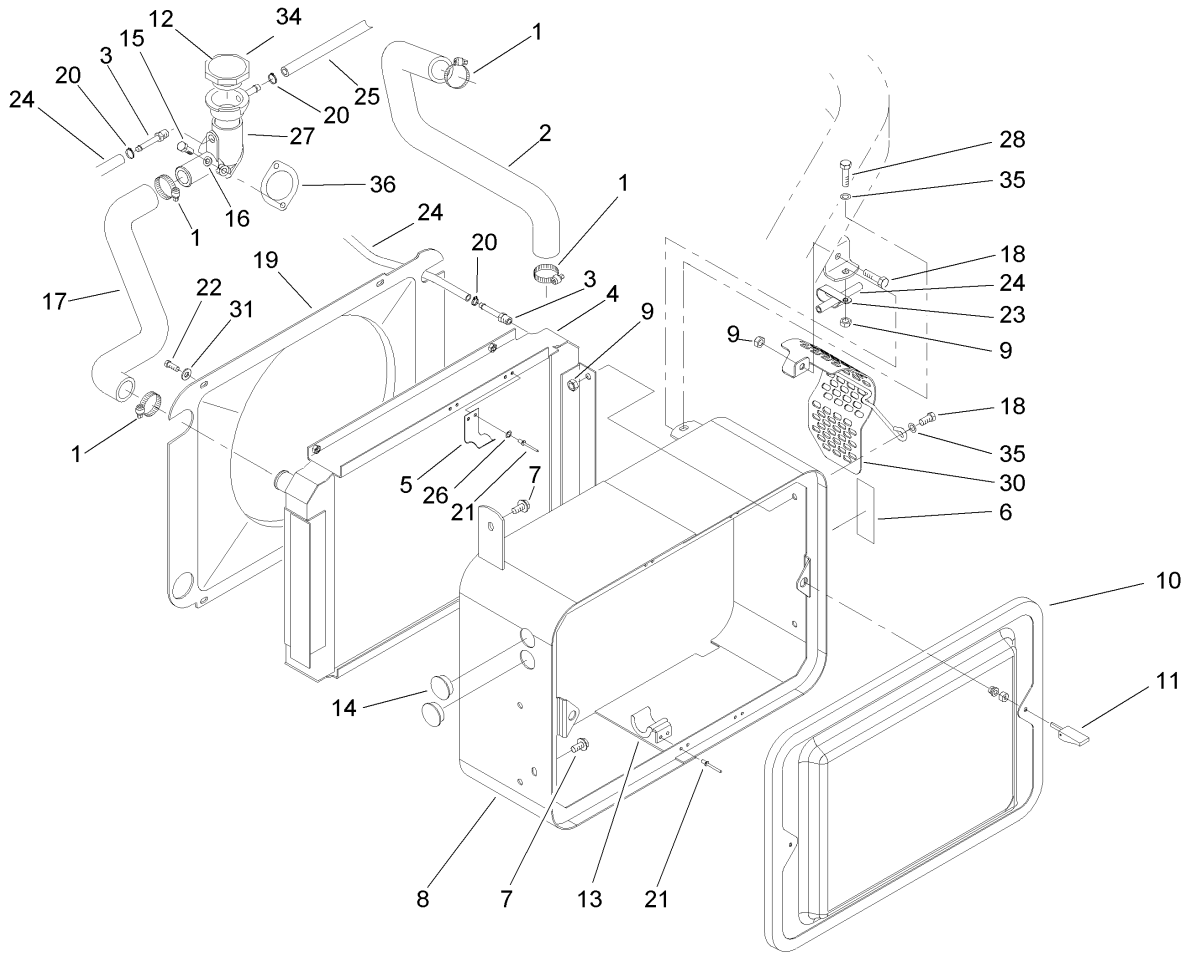

Radiator Assembly

Ref	Part No.	Qty.	Description
1	2412-34	4	Clamp-Hose
2	99-1469	1	Hose-Radiator
3	304-73	2	Connector-Hose
4	99-8193	1	Radiator
5	104-7736	1	Bracket-Cooler, Upper
6	93-6681	1	Decal-Warning, Fan
7	32104-32	2	Screw-HWH
8	106-9056-01	1	Support-Radiator
9	33024-00	6	Nut-Lock
10	100-3172-03	1	Screen ASM
11	74-5950	2	Latch-Swell
12	106-5976	1	Decal-Warning
13	93-2424	2	Bracket-Cooler, Lower
14	94-4528	2	Plug
15	33113-025	2	Screw-HH
16	3253-3	2	Washer-Lock
17	93-2018	1	Hose-Radiator
18	33114-020	5	Screw-HH
19	93-2320	1	Shroud-Fan
20	2412-108	3	Clamp-Worm
21	3269-15	6	Rivet
22	33113-016	4	Screw-HH
23	92-5753	1	Clamp-Hose
24	109-0281	1	Hose-Fuel

Ref	Part No.	Qty.	Description
25	110-4112	1	Hose-Fuel
26	3269-6	2	Washer
27	93-2448	1	Thermostat Housing ASM
28	33114-025	1	Screw-HH
30	100-3164-03	1	Guard-Alternator
31	3256-22	4	Washer-Flat
34	66-3240	1	Cap-Radiator
35	3256-23	2	Washer-Flat
36	99-9163	1	Gasket-Outlet

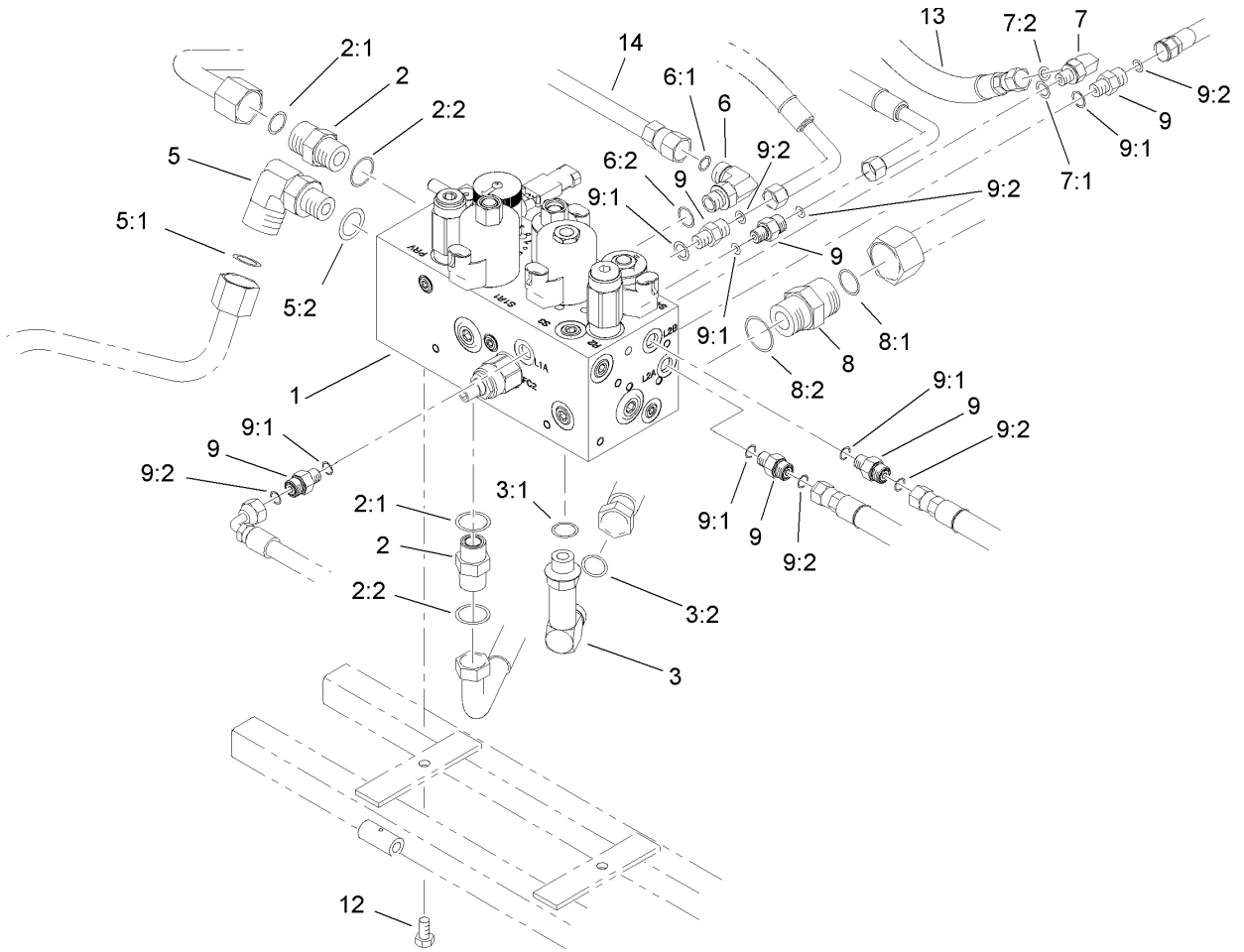

Manifold Block Installation Assembly

Ref	Part No.	Qty.	Description
1	112-9197	1	Manifold ASM W/Backlap
2	340-7	2	Adapter
2:1	237-65	1	O-Ring
2:2	237-80	1	O-Ring
3	99-6160	1	Fitting-Elbow, 90 DEG
3:1	237-30	1	O-Ring
3:2	237-79	1	O-Ring
5	340-17	1	Fitting-HYD, 90 DEG
5:1	237-65	1	O-Ring
5:2	237-80	1	O-Ring
6	340-77	1	Fitting-HYD, 90 DEG
6:1	237-22	1	O-Ring
6:2	237-42	1	O-Ring
7	340-97	1	Fitting-HYD, 90 DEG
7:1	237-22	1	O-Ring
7:2	237-78	1	O-Ring
8	340-9	1	Fitting-Straight
8:1	237-58	1	O-Ring
8:2	237-81	1	O-Ring
9	340-92	5	Fitting-HYD, Straight
9:1	237-78	1	O-Ring
9:2	237-21	1	O-Ring
12	33114-016	2	Screw-HH
13	112-0274	1	Hose-HYD

Ref	Part No.	Qty.	Description
●13:3	237-42	1	O-Ring
14	105-9790	1	Hose ASM

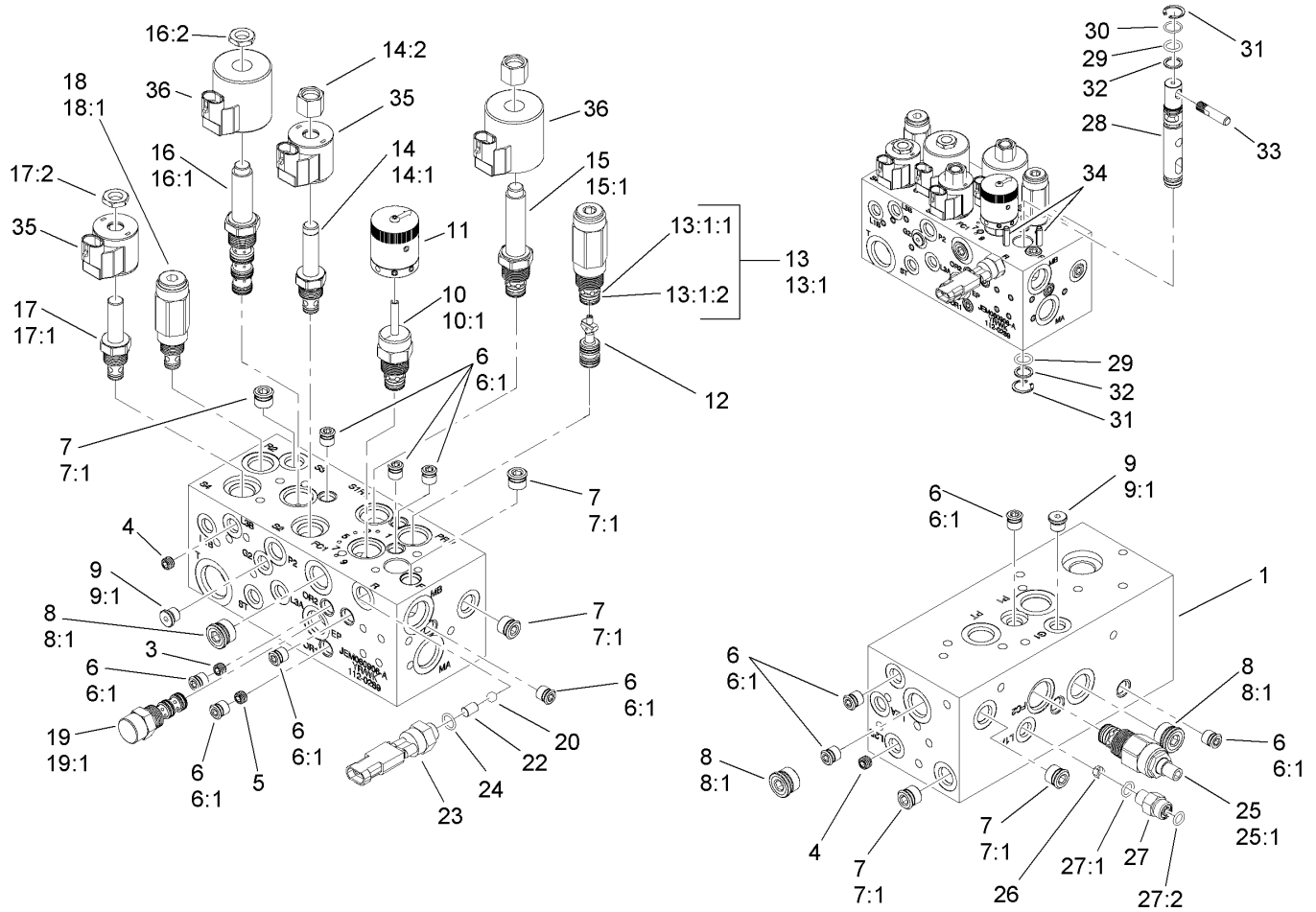

Hydraulic Manifold Assembly No. 112-9197

Ref	Part No.	Qty.	Description
1		1	Body-Manifold
3	112-9202	1	Orifice-Flow, Control
4	110-8887	2	Plug-Orifice
5	112-9203	1	Orifice-Control, Flow
6	106-1025	12	Plug-HYD
6:1	237-78	1	O-Ring
7	106-1026	5	Plug-HYD
7:1	237-42	1	O-Ring
8	106-1027	3	Plug-HYD
8:1	237-79	1	O-Ring
9	353-990	2	Plug
9:1	237-78	1	O-Ring
10	110-8769	1	Valve-Control, Manual Flow
10:1	110-2633	1	Seal Kit
11	110-8767	1	Rotary Handle ASM
12	112-9204	1	Pilot-Piston
13	112-9205	1	Valve-Relief
13:1	105-9159	1	Seal Kit
13:1:1		1	O-Ring
13:1:2		1	Ring-Back Up
14	107-7517	1	Valve-Solenoid
14:1	105-9156	1	Seal Kit
14:2	107-7812	1	Nut-Solenoid
15	110-8768	1	Valve-Relief, Solenoid

Ref	Part No.	Qty.	Description
15:1	110-6316	1	Seal Kit
16	110-8906	1	Valve-Solenoid
16:1	110-8908	1	Seal Kit
16:2	110-2634	1	Nut-Coil
17	112-9206	1	Solenoid Valve
17:1	105-9156	1	Seal Kit
17:2	110-2634	1	Nut-Coil
18	112-9207	1	Valve-Relief
18:1	105-9156	1	Seal Kit
19	110-8988	1	Element-Logic
19:1	110-8773	1	Seal Kit
20	110-8762	1	Ball-Chrome
22	112-6533	1	Pin-Dowel
23	72-4320	1	Switch-Ball
24	110-8757	1	O-Ring
25	112-9208	1	Flow Control
25:1	110-2633	1	Seal Kit
26	110-8903	1	Orifice-Control, Flow
27	340-92	1	Fitting-HYD, Straight
27:1	237-78	1	O-Ring
27:2	237-21	1	O-Ring
28	112-6536	1	Spool
29	112-6535	2	O-Ring
30	110-8900	1	O-Ring

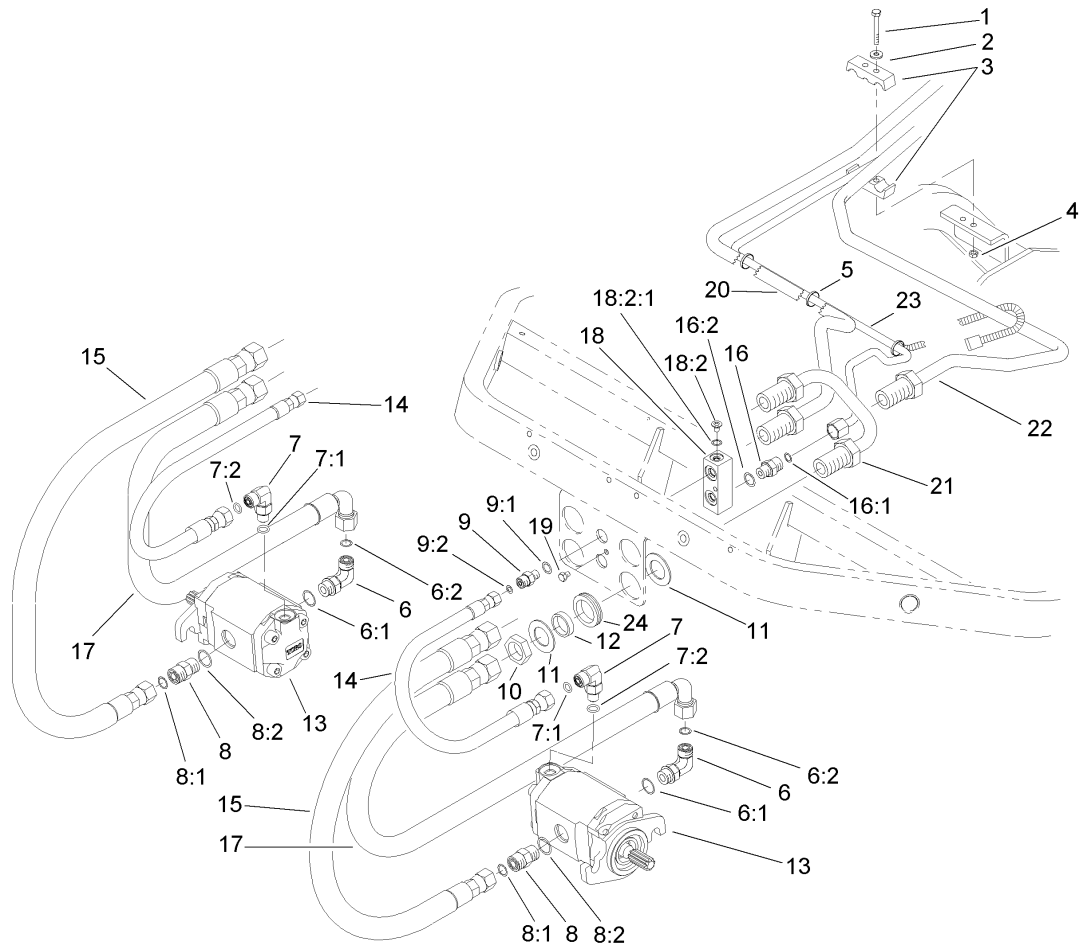

Front Bulkhead and Reel Motor Assembly

Ref	Part No.	Qty.	Description
1	33113-050	2	Screw-HH
2	3256-1	2	Washer-Flat
3	93-2509	2	Clamp-Tube
4	33023-00	2	Nut-Lock
5	3290-378	3	Tie-Cable
6	340-98	2	Fitting-HYD, 90 DEG
6:1	237-79	1	O-Ring
6:2	237-30	1	O-Ring
7	340-132	2	Fitting-HYD, 90 DEG
7:1	237-78	1	O-Ring
7:2	237-21	1	O-Ring
8	340-4	2	Fitting-HYD, Straight
8:1	237-30	1	O-Ring
8:2	237-79	1	O-Ring
9	340-92	2	Fitting-HYD, Straight
9:1	237-78	1	O-Ring
9:2	237-21	1	O-Ring
10	340-74	2	Locknut-Bulkhead
11	69-9010	4	Washer
12	69-9000	2	Spacer
13	112-9200	2	Motor-HYD
14	106-9674	2	HYD Hose ASM
15	95-2908	2	Hose ASM
16	340-2	1	Fitting-HYD, Straight

Ref	Part No.	Qty.	Description
16:1	237-22	1	O-Ring
16:2	237-42	1	O-Ring
17	95-2909	2	Hose ASM
18	93-2238	1	T-Block
18:2	353-991	1	Plug-Hex, Hollow
18:2:1	237-156	1	O-Ring
19	33113-008	1	Screw-HH
20	94-1318	1	Tube-HYD
21	94-1319	1	Tube-HYD
22	94-1320	1	Tube-HYD
23	94-1321	1	Tube-HYD
23:1	237-22	2	O-Ring
24	240-3	2	Grommet-Rubber

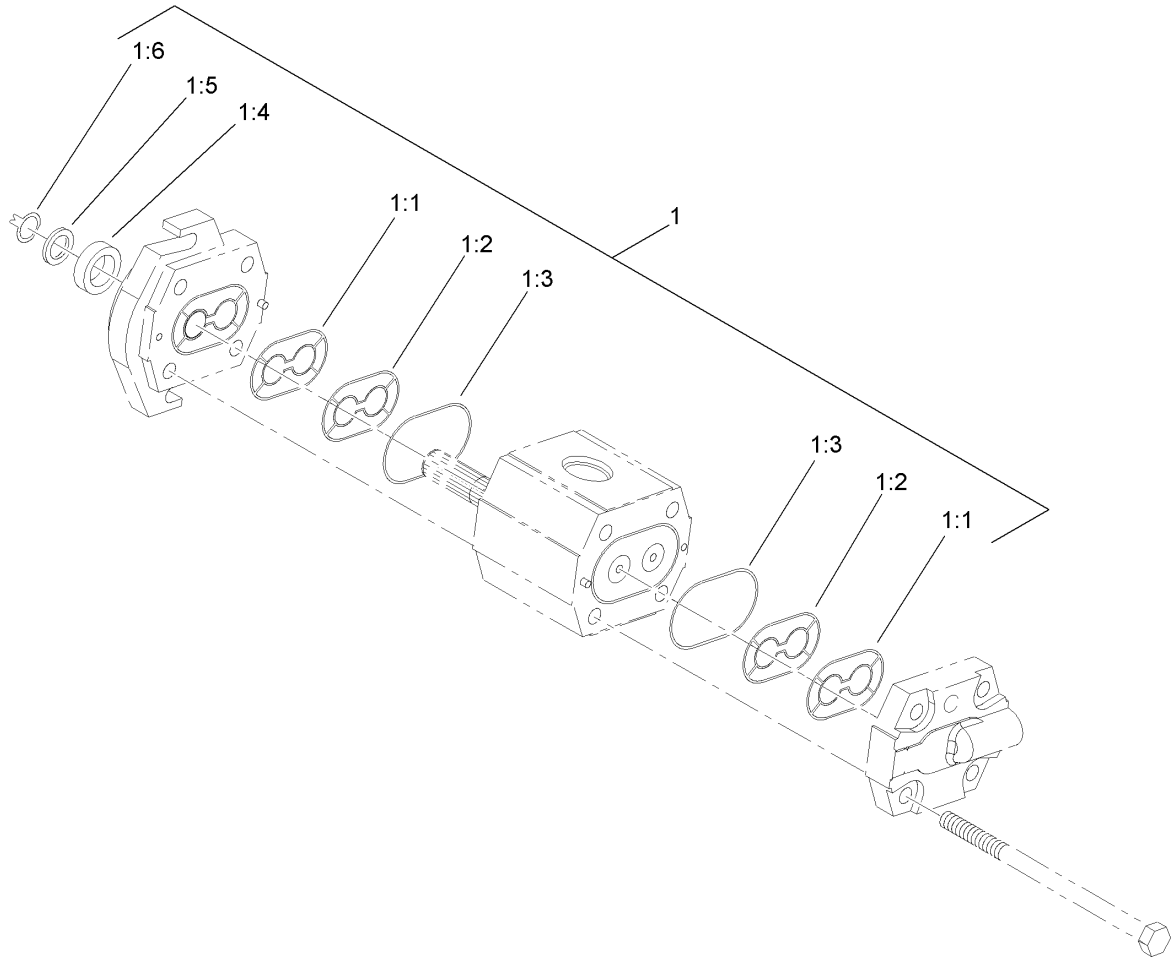

Hydraulic Motor Assembly No. 112-9200

Ref	Part No.	Qty.	Description
1	112-9184	1	Kit-Seal
② 1:1		2	Seal-Extrusion, Anti
② 1:2		2	Seal-Pressure
② 1:3		2	O-Ring
② 1:4		1	Seal-Shaft
② 1:5		1	Washer-Backup
② 1:6		1	Ring-Snap

--	--	--	--

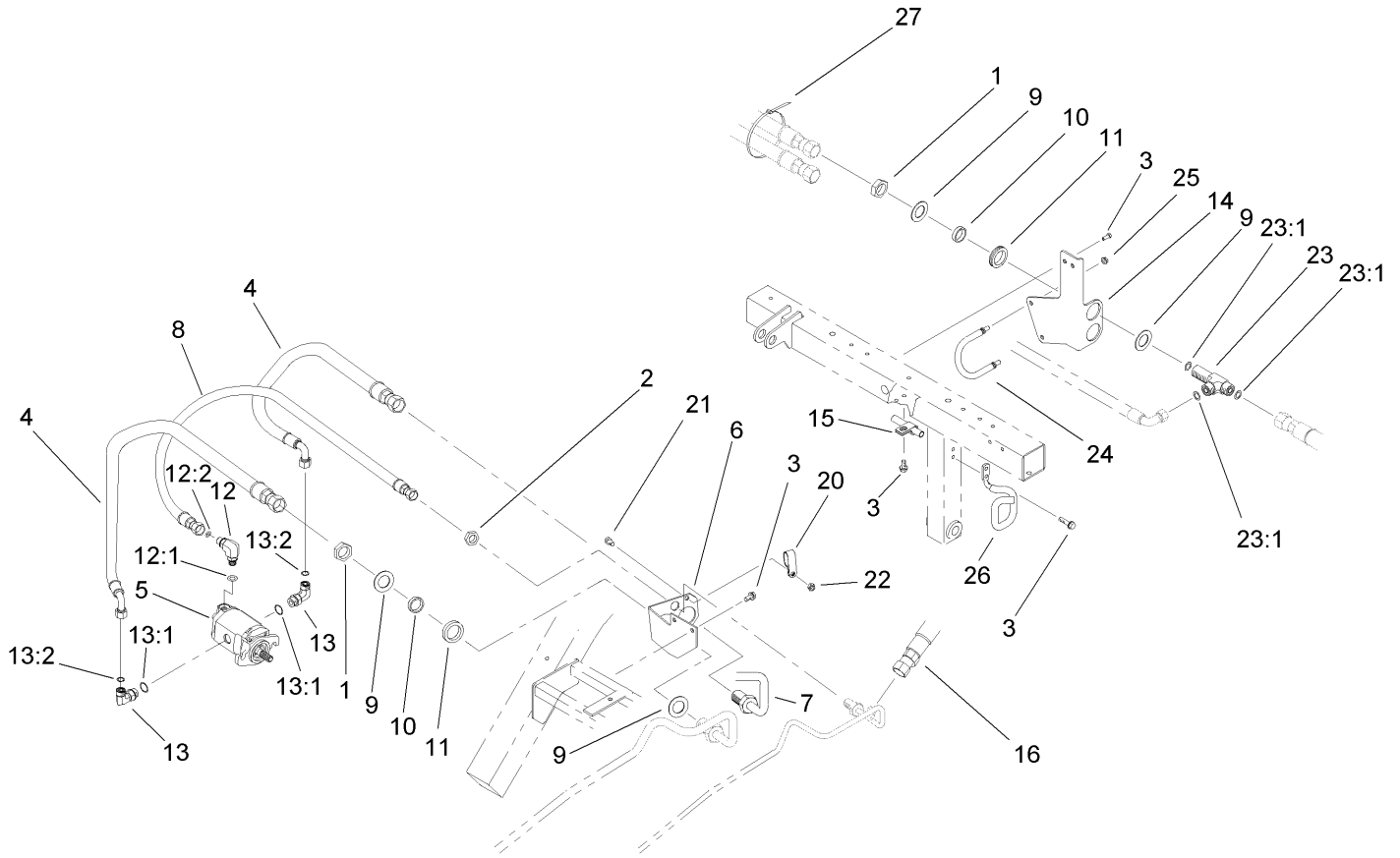

Rear Bulkhead and Reel Motor Assembly

Ref	Part No.	Qty.	Description
1	340-74	4	Locknut-Bulkhead
2	340-70	1	Nut-Lock
3	32104-32	7	Screw-HWH
4	95-2907	2	Hose ASM
5	112-9200	1	Motor-HYD
6	94-1316	1	Bracket-Bulkhead
7	94-1317	1	Tube-HYD
8	105-5405	1	Hose ASM
9	69-9010	8	Washer
10	69-9000	4	Spacer
11	240-3	4	Grommet-Rubber
12	340-132	1	Fitting-HYD, 90 DEG
12:1	237-78	1	O-Ring
12:2	237-21	1	O-Ring
13	340-98	2	Fitting-HYD, 90 DEG
13:1	237-79	1	O-Ring
13:2	237-30	1	O-Ring
14	99-4222-03	1	Bracket-Hose
15	2412-4	1	Clamp
16	110-4008	1	HYD Hose ASM
20	2412-137	1	Clamp-R, Double
21	33114-020	1	Screw-HH
22	33024-00	1	Nut-Lock
23	94-5350	2	Tee-Bulkhead

Ref	Part No.	Qty.	Description
23:1	237-65	3	O-Ring
24	99-4221	1	Retainer-Hose
25	3296-29	2	Nut-Lock, NI
26	94-5352	1	Retainer-Hose
27	3290-378	1	Tie-Cable

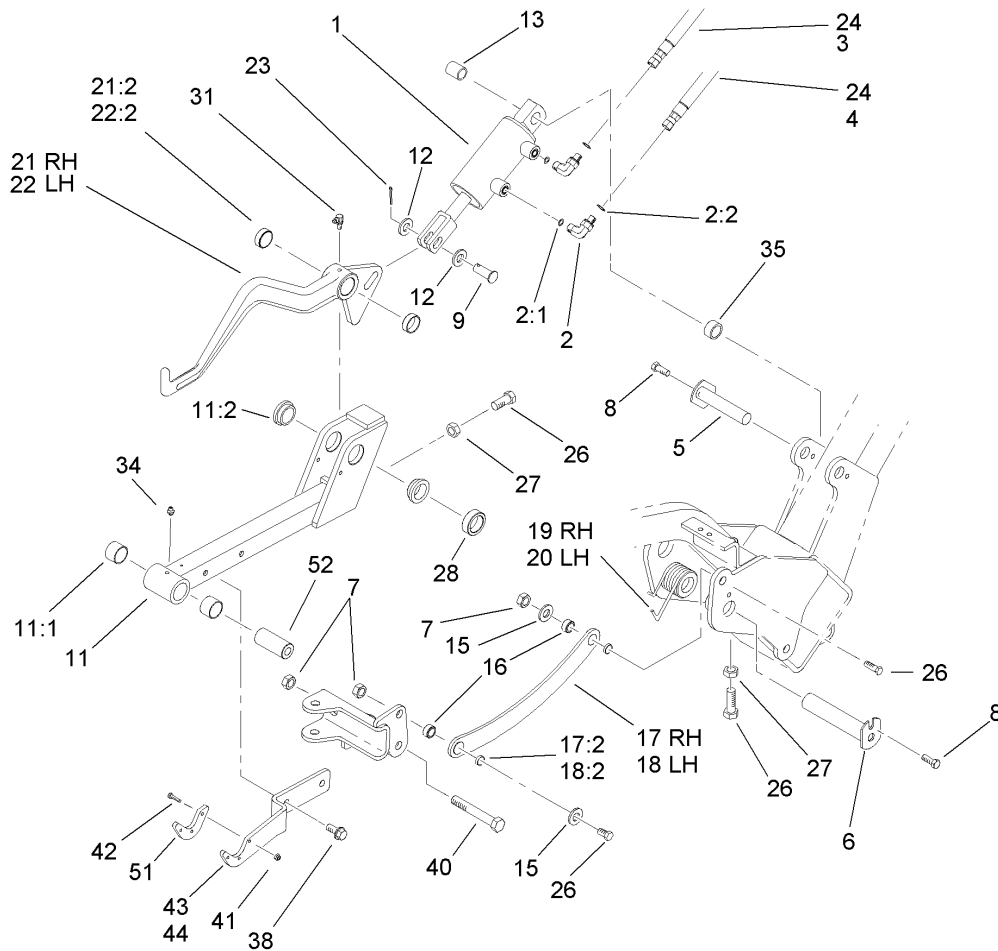

Left Hand and Right Hand Lift Arm Assembly

Ref	Part No.	Qty.	Description
1	105-3821	2	HYD Cylinder ASM
2	340-132	4	Fitting-HYD, 90 DEG
2:1	237-78	1	O-Ring
2:2	237-21	1	O-Ring
3	108-6505	1	Hose ASM
4	112-9193	1	Hose ASM
5	10-6060	2	Pin-Pivot
6	94-8198	2	Pin
7	3296-25	6	Nut-Lock, NI
8	32104-32	4	Screw-HWH
9	283-68	2	Pin-Clevis
11	99-4115	2	Front Lift Frame ASM
11:1	98-4166	2	Bushing
11:2	94-9610	2	Bushing-Flange
12	33096-00	4	Washer-Flat
13	105-3838	2	Spacer
15	3256-26	4	Washer-Flat
16	99-4201	4	Tube-Spacer
17	99-4258	1	RH Link Bracket ASM
17:2	99-4243	2	Bushing-Flange
18	99-4260	1	LH Link Bracket ASM
18:2	99-4243	2	Bushing-Flange
19	105-3809	1	Spring-Torsion, RH
20	105-3818	1	Spring-Torsion, LH

Ref	Part No.	Qty.	Description
21	99-4213	1	RH Lift Arm ASM
21:2	92-8995	2	Bushing
22	99-4212	1	LH Lift Arm ASM
22:2	92-8995	2	Bushing
23	3272-11	2	Pin-Cotter
24	93-2254	2	HYD Hose ASM
26	325-7	8	Screw-HH
27	3218-5	3	Nut-Jam
28	93-2384	2	Spacer-Carrier
31	302-60	2	Fitting-Grease, 90 DEG
34	302-5	2	Fitting-Grease
35	74-3730	2	Spacer-Spindle, Rear
38	32144-69	4	Screw-HH
40	325-14	2	Screw-HH
41	3296-54	6	Nut-Lock
42	3250-17	6	Screw-PPH
43	99-4111-01	1	Plate-Transport, 1 And 3
44	99-4112-01	1	Plate-Transport, 2
51	99-4225	2	Pad-Wear
52	99-4072	2	Spacer

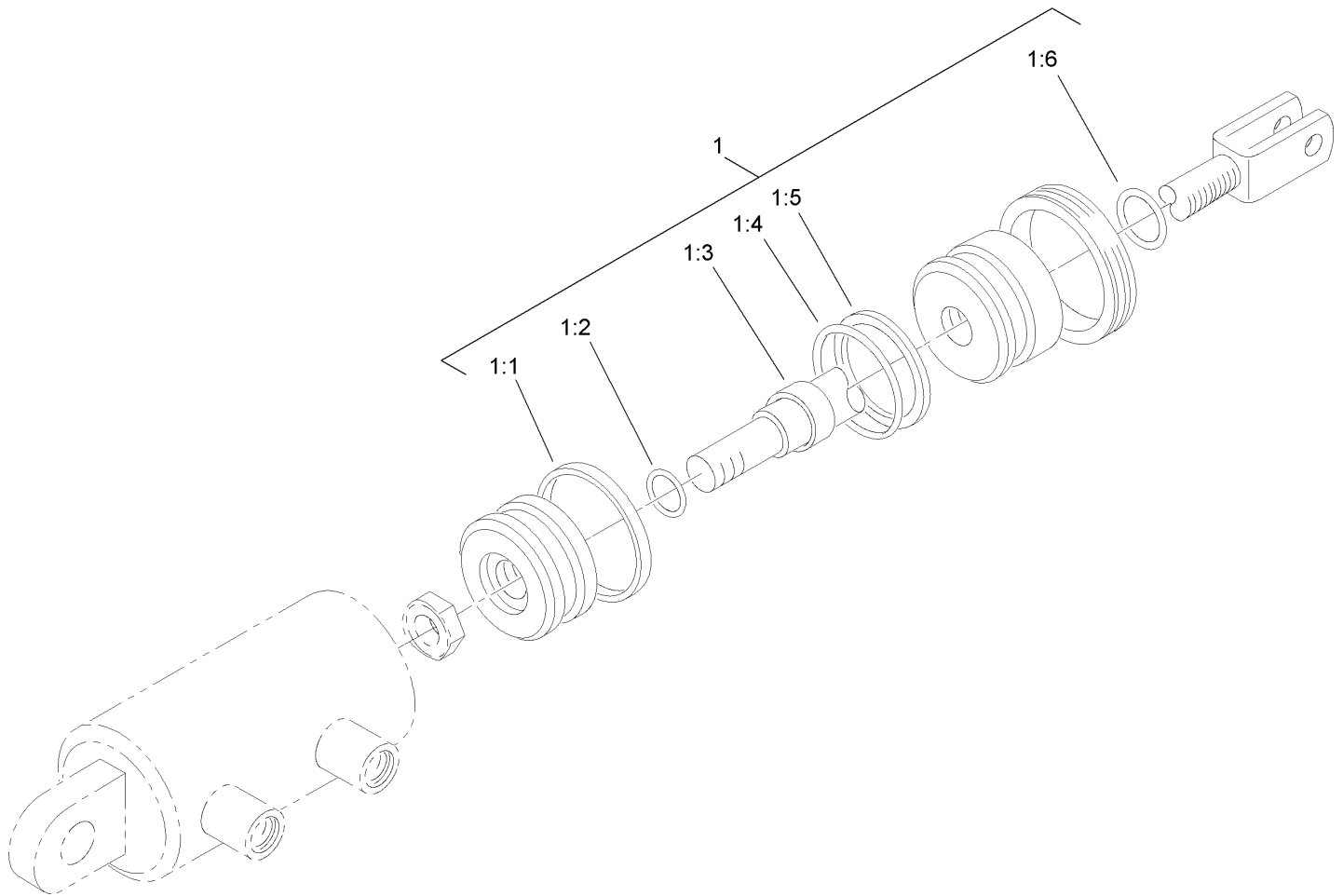

Hydraulic Cylinder Assembly No. 105-3821

Ref	Part No.	Qty.	Description
1	105-3836	1	Seal Kit
②1:1		1	T-Seal
②1:2		1	O-Ring
②1:3		1	Seal-Rod
②1:4		1	O-Ring
②1:5		1	Backup
②1:6		1	Seal-Dust

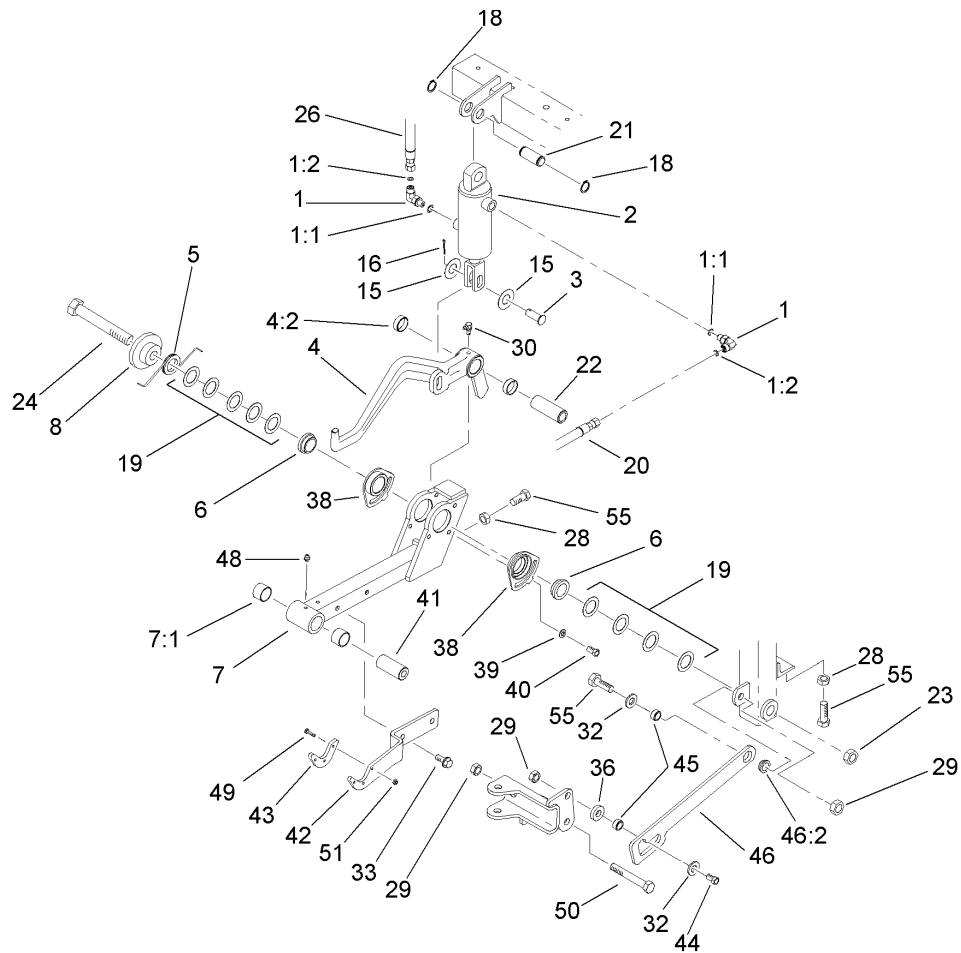

Center Lift Arm Assembly

Ref	Part No.	Qty.	Description
1	340-132	2	Fitting-HYD, 90 DEG
1:1	237-78	1	O-Ring
1:2	237-21	1	O-Ring
2	105-3820	1	HYD Cylinder ASM
3	283-68	1	Pin-Clevis
4	99-4126	1	Center Lift Arm ASM
4:2	92-8995	2	Bushing
5	105-9781	1	Spring-Torsion
6	98-2197	2	Bushing-Flange
7	99-4116	1	Rear Lift Frame ASM
7:1	98-4166	2	Bushing
8	105-9779	1	Guide-Spring
15	33096-00	2	Washer-Flat
16	3272-11	1	Pin-Cotter
18	32120-72	2	Ring-Snap
19	63-2290	9	Washer-Thrust
20	112-9185	1	Hose-HYD
21	94-3452	1	Pin
22	94-8199	1	Tube-Pivot
23	3296-53	1	Nut-Lock, NI
24	327-25	1	Screw-HH
26	106-7981	1	Hose-HYD
28	3218-5	2	Nut-Jam
29	3296-25	3	Nut-Lock, NI

Ref	Part No.	Qty.	Description
30	302-60	1	Fitting-Grease, 90 DEG
32	3256-26	2	Washer-Flat
33	32144-69	2	Screw-HH
36	99-4248	1	Spacer
38	98-4618	2	Bushing-Eccentric
39	3256-74	2	Washer-Flat
40	33114-016	2	Screw-HH
41	99-4072	1	Spacer
42	99-4111-01	1	Plate-Transport, 1 And 3
43	99-4225	1	Pad-Wear
44	325-7	1	Screw-HH
45	99-4201	2	Tube-Spacer
46	99-4246	1	Link Bracket ASM
46:2	99-4243	1	Bushing-Flange
48	302-5	1	Fitting-Grease
49	3250-17	3	Screw-PPH
50	325-14	1	Screw-HH
51	3296-54	3	Nut-Lock
55	325-7	3	Screw-HH

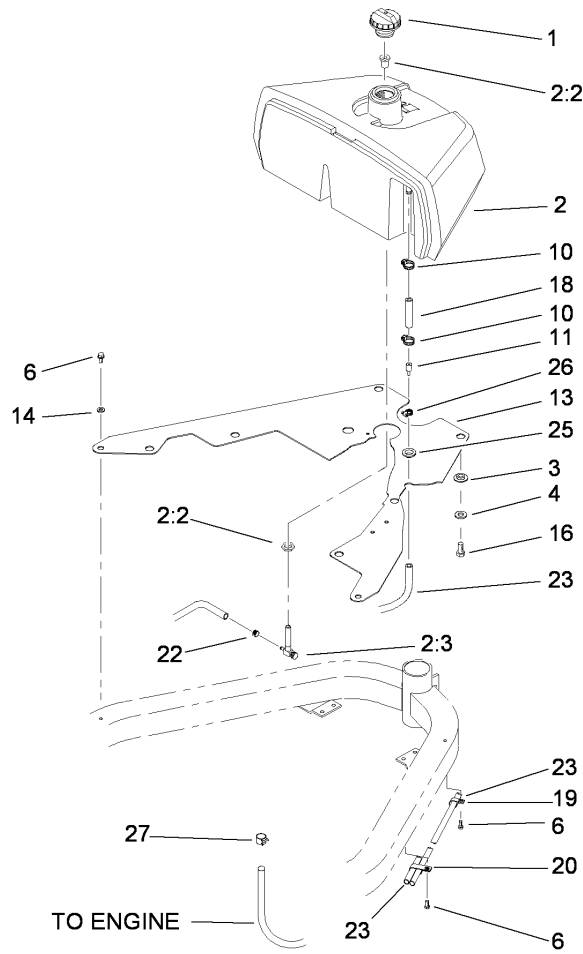

Fuel System Assembly

Ref	Part No.	Qty.	Description
1	115-3002	1	Cap-Biodiesel
2	114-4680	1	Diesel Tank ASM
2:2	114-4677	1	Bulkhead ASM
2:3	114-4679	1	Fitting-90 DEG, W/Strainer
3	240-11	3	Bushing-Flange
4	93-4637	3	Washer-Flat
6	32104-32	5	Screw-HWH
10	2412-36	2	Clamp-Hose
11	112-0212	1	Fitting-Fuel
13	94-1364-03	1	Plate ASM
14	3256-23	2	Washer-Flat
16	33115-020	3	Screw-HH
18	106-1128	1	Hose-Fuel
19	2412-41	1	Clamp
20	92-5753	1	Clamp-Hose
22	92-2379	1	Clamp-Hose
23	110-3958	1	Hose-Fuel
25	237-124	1	Grommet
26	2412-108	1	Clamp-Worm
27	2412-146	1	Clamp-Hose

--	--	--	--

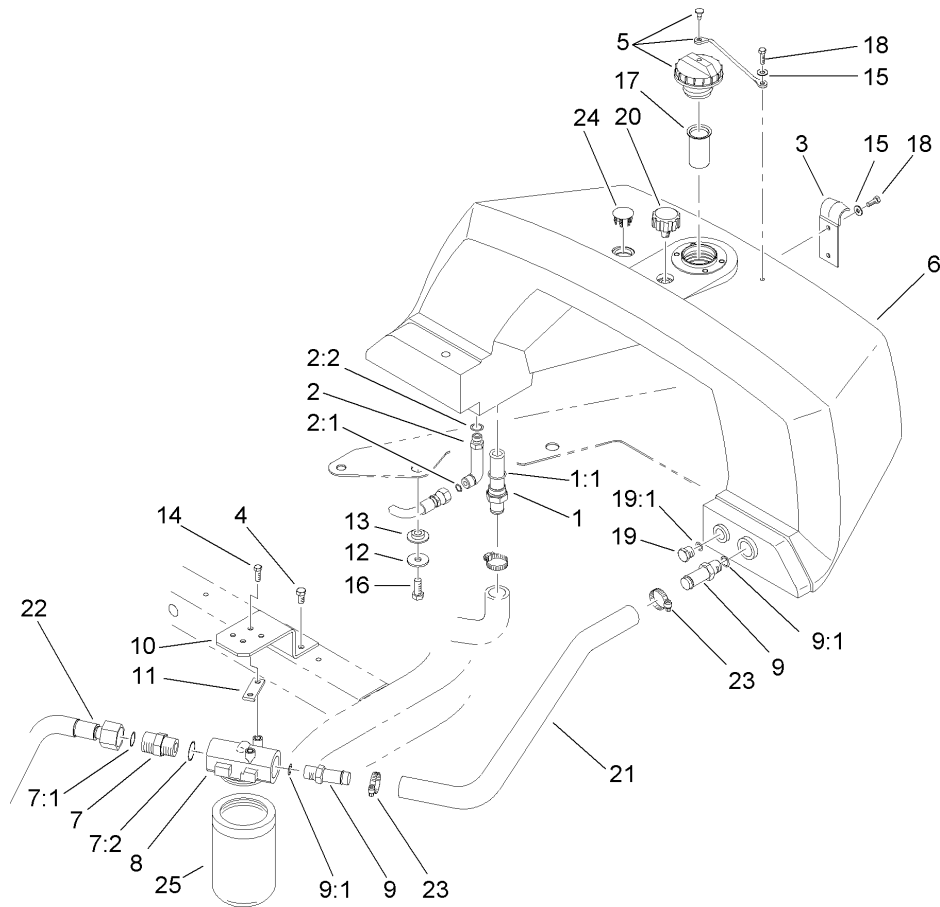

Hydraulic Tank and Filter Assembly

Ref	Part No.	Qty.	Description
1	112-0211	1	Strainer Fitting ASM
1:1	237-146	1	O-Ring
2	69-4320	1	Fitting-HYD, 90 DEG
2:1	237-22	1	O-Ring
2:2	237-42	1	O-Ring
3	93-2438	1	Clamp-Tank, Fuel
4	32104-32	2	Screw-HWH
5	93-7160	1	Cap-Oil, HYD
6	93-2235	1	Tank-HYD
7	340-9	1	Fitting-Straight
7:1	237-58	1	O-Ring
7:2	237-81	1	O-Ring
8	92-5821	1	Filter Head ASM
9	354-73	2	Fitting-Straight
9:1	237-81	1	O-Ring
10	105-9793-03	1	Mount-Filter, Oil
11	105-4309	1	Plate-Filter
12	93-4637	4	Washer-Flat
13	240-11	4	Bushing-Flange
14	321-5	2	Screw-HH
15	3256-1	3	Washer-Flat
16	33115-020	4	Screw-HH
17	93-2275	1	Screen-Filler
18	33113-016	3	Screw-HH

Ref	Part No.	Qty.	Description
19	353-988	1	Plug-Hex
19:1	237-79	1	O-Ring
20	68-6150	1	Breather
21	94-9607	1	Hose-Return
22	94-4518	1	Tube ASM
23	2412-129	2	Clamp-Hose
24	93-2437	1	Plug-Serrated
25	107-9531	1	Filter-Oil, HYD

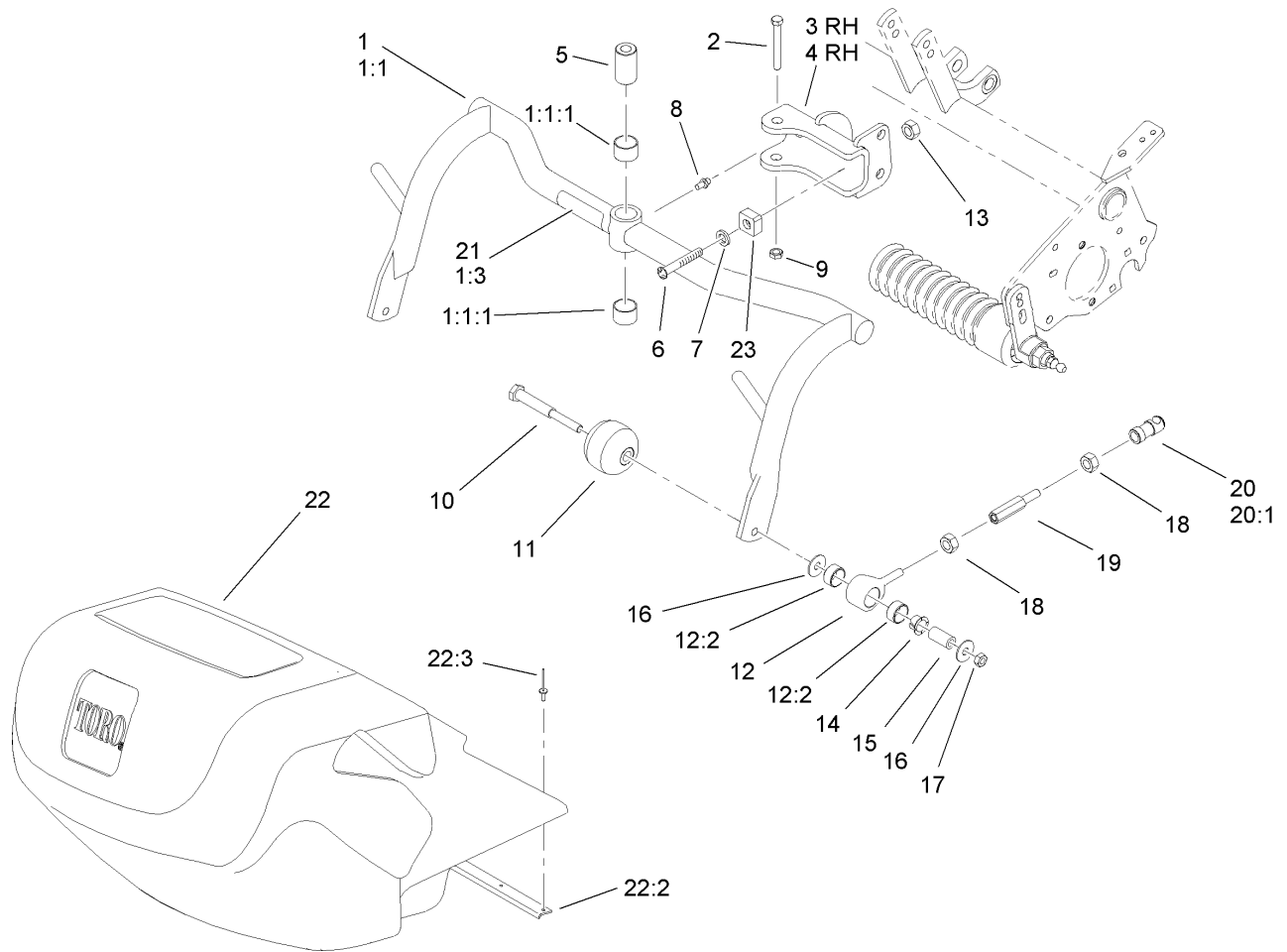

Pull Frame Assembly

Ref	Part No.	Qty.	Description
1	99-4114	3	Pull Frame ASM
② 1:1		1	Pull Frame And Bushing ASM
1:1:1	98-4166	2	Bushing
1:3	104-7728	1	Decal-Danger
2	325-13	3	Screw-HH
3	99-4183-01	2	RH Clevis ASM
4	99-4182-01	1	LH Clevis ASM
5	99-4109	3	Spacer
6	78-8710	3	Screw
7	3256-77	3	Washer-Flat
8	302-5	3	Fitting-Grease
9	3296-25	3	Nut-Lock, NI
10	108-6543	6	Shaft-Roller
11	99-4210	6	Roller-Anti Scalp
12	108-6542	6	Pull Link ASM
12:2	95-0532	2	Rubber Bushing ASM
13	3296-12	3	Nut-Lock
14	104-7738	12	Bushing-Flange
15	108-6544	6	Spacer
16	52-2860	12	Washer
17	3296-59	6	Nut-Lock, NI
18	3220-3	12	Nut-HJ
19	88-6870	6	Extension-Arm, Pull
20	99-1460	6	Ball Joint Receiver ASM

Ref	Part No.	Qty.	Description
20:1	99-1461	1	Sleeve-Joint, Ball
21	104-7729	3	Decal-Danger (Europe)
22	106-4689	3	Grass Basket ASM
22:2	104-2607	1	Strip-Basket
22:3	3290-382	8	Rivet-Pop
23	94-1392	3	Pad-Rubber

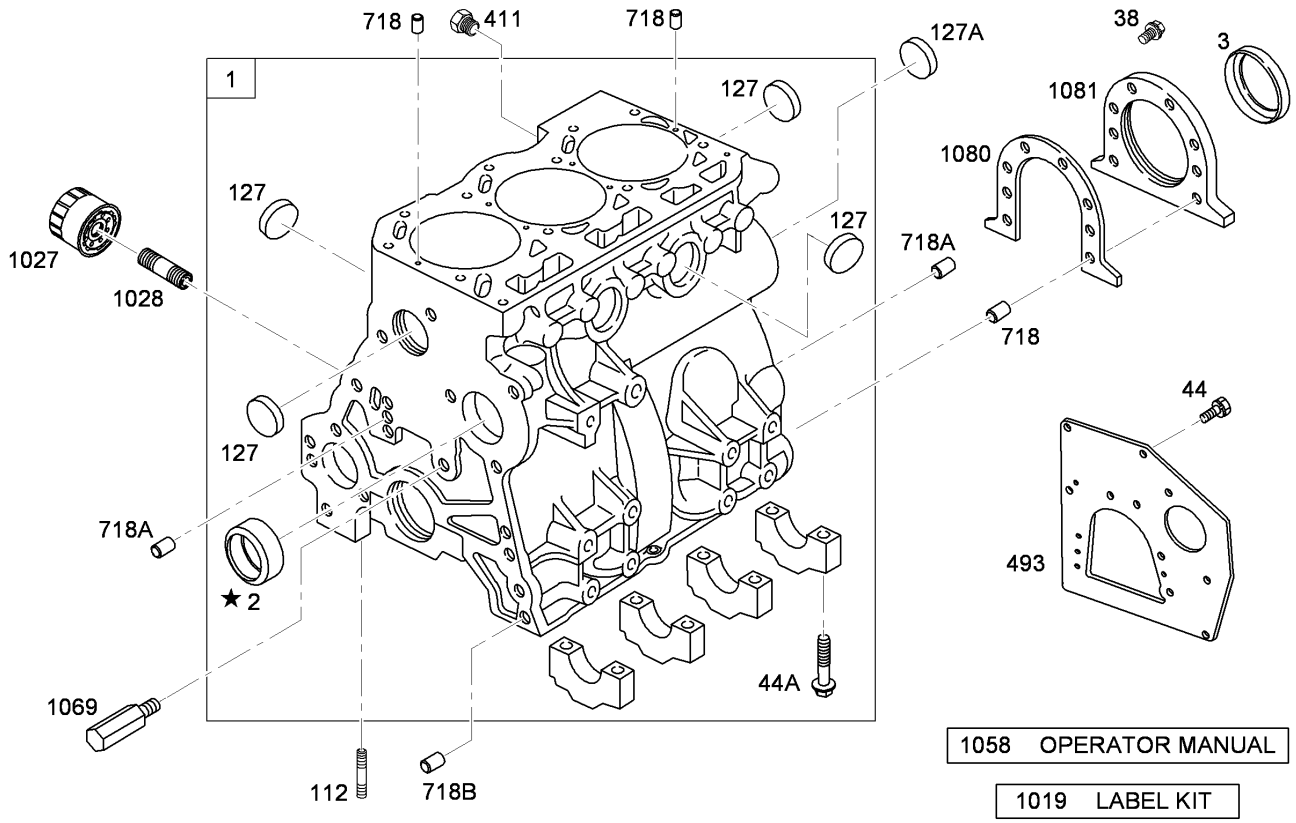

★ Requires Special Tools To Install
See Repair Manual For Instructions

Assemblies include all parts shown in frames

Cylinder Assembly

Ref	Part No.	Qty.	Description
1	100-6401	1	Cylinder ASM
2	99-9002	1	Bushing
3	99-9003	1	Seal-Oil
38	99-9004	6	Screw-Hex
44	99-9005	3	Screw-Hex
44A	99-9006	8	Screw-Hex
112	99-9007	1	Stud-Metric
127	99-9008	7	Plug-Welch
127A	99-9010	1	Plug-Welch
411	99-9601	1	Plug (Cylinder Block)
493	100-3195	1	Bracket-Mounting
718	99-9012	4	Pin-Locating
718A	99-9013	3	Pin-Locating
718B	99-9014	2	Pin-Locating
1019	99-9015	1	Label Kit
1027	99-9017	1	Filter-Oil
1028	99-9018	1	Adapter-Filter, Oil
1058	99-9602	1	Manual-Owner's
1069	99-9020	1	Nozzle-Oil
1080	99-9021	1	Gasket-Retainer
1081	99-9022	1	Retainer-Seal

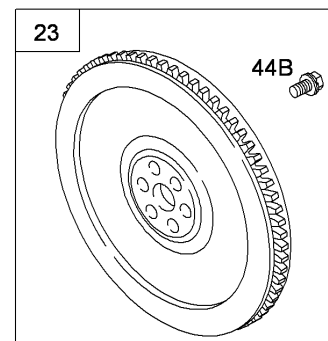
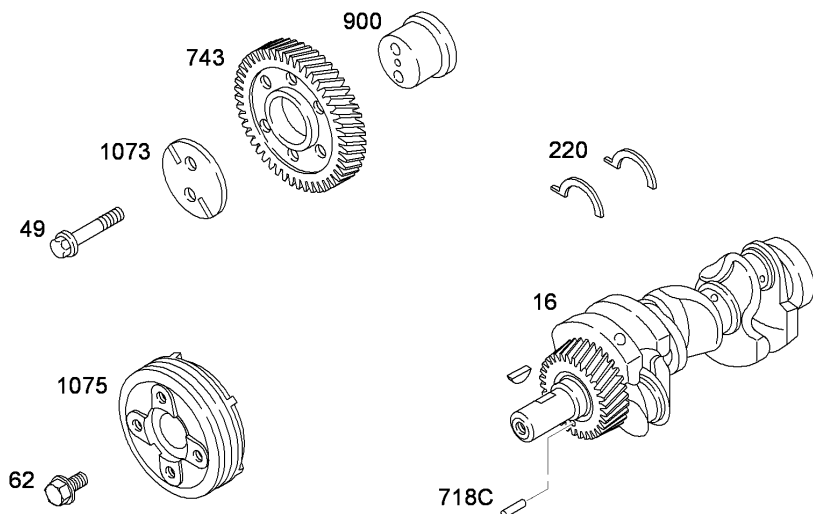
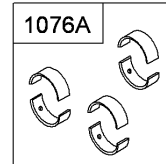
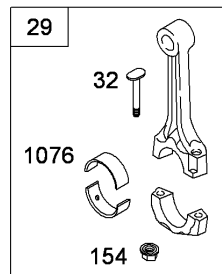
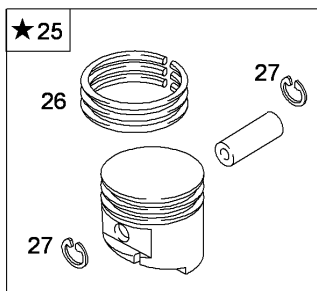
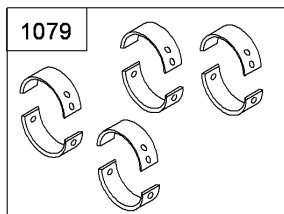

★ Requires Special Tools To Install
See Repair Manual For Instructions

Assemblies include all parts shown in frames

Crankshaft Assembly

Ref	Part No.	Qty.	Description
16	99-9252	1	Crankshaft
23	99-9267	1	Flywheel
25	99-9605	3	Piston ASM
25	99-9268	3	Piston ASM (.010 Oversized)
26	99-9606	3	Ring Set
26	99-9269	3	Ring Set (.010 In Oversized)
27	99-9607	6	Lock-Pin, Piston
29	99-9608	3	Rod-Connecting
32	99-9030	6	Screw-Rod, Connecting
44B	99-9031	6	Screw-Hex
49	99-9032	2	Screw-Hex
62	99-9033	1	Screw-Hex
154	99-9034	6	Nut-Hex
220	99-9035	1	Washer-Thrust
220	99-9036	1	Washer-Thrust (.005 In Oversized)
718C	99-9037	1	Pin-Locating
743	99-9609	1	Gear-Drive
900	99-9039	1	Shaft-Gear
1073	99-9040	1	Plate-Gear, Idler
1075	99-9692	1	Pully-Crankshaft
1076	99-9042	1	Bearing-Rod
1076A	99-9043	3	Set-Bearing, Rod

Ref	Part No.	Qty.	Description
1076A	99-9044	3	Set-Bearing, Rod (.010 Undersized)
1079	99-9045	1	Set-Bearing, Main (Set Of 8)
1079	99-9046	1	Set-Bearing, Main (.010 Undersized)

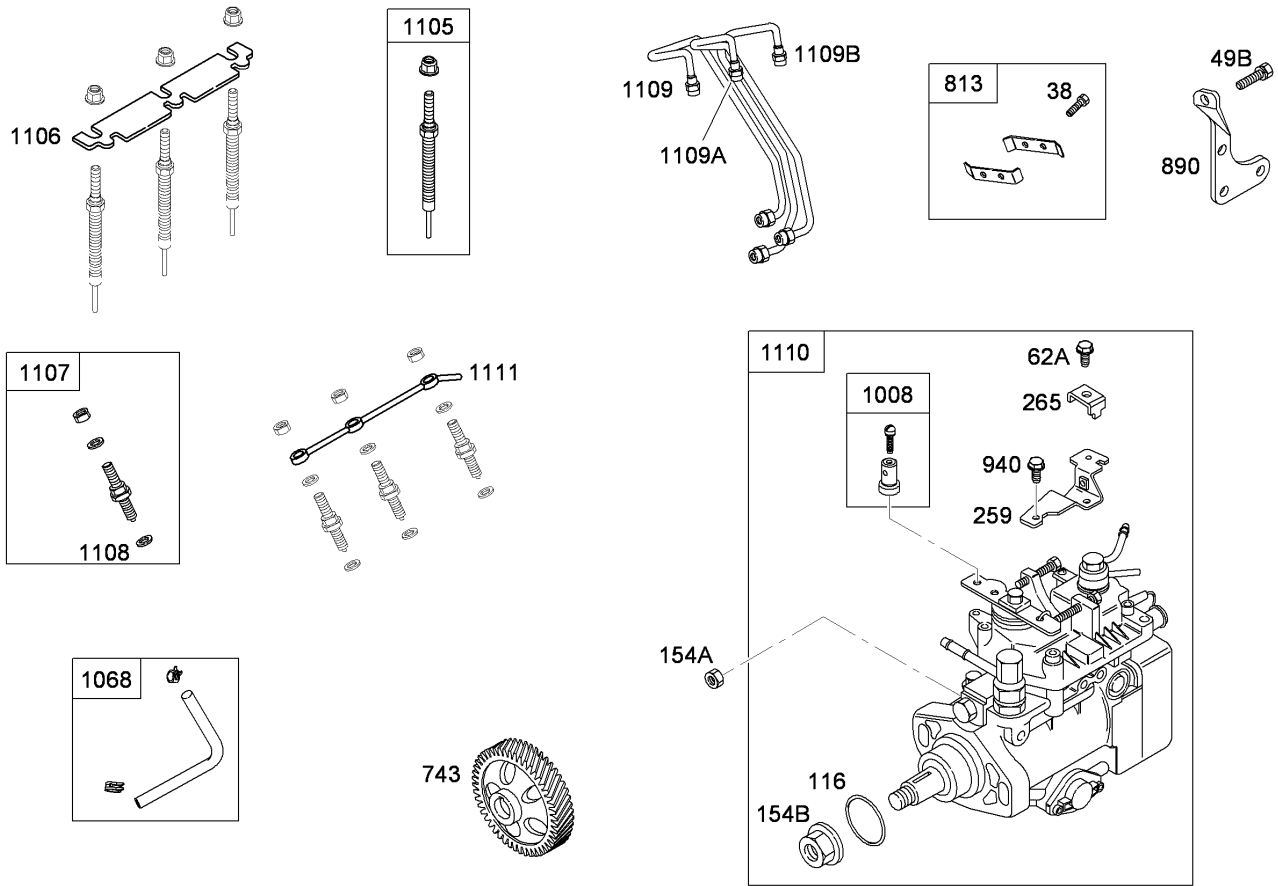

Assemblies include all parts shown in frames

Injection Assembly

Ref	Part No.	Qty.	Description
38	99-9004	2	Screw-Hex
49B	99-9616	4	Screw-Hex
62A	100-6403	1	Screw-Metric
116	99-9618	1	O-Ring
154A	99-9619	2	Nut-Hex, Metric
154B	99-9620	1	Nut-Hex, Metric
259	99-9621	1	Bracket-Clamp, Casing
265	99-9622	1	Clamp-Casing
743	99-9624	1	Gear-Drive
813	99-9625	1	Clamp
890	99-9626	1	Bracket-Support
940	100-6410	2	Screw-Hex
1008	99-9628	1	Clamp-Swivel
1068	99-9629	1	Hose / Clamp ASM
1105	114-4695	3	Plug-Glow
1106	99-9631	1	Strap-Plug, Glow
1107	114-4696	3	Injection Nozzle
1108	99-9633	3	Seat-Injector
1109	99-9690	1	Pipe-Injector, No. 1
1109A	99-9634	1	Pipe-Injector, No. 2
1109B	99-9635	1	Pipe-Injector, No. 3
1110	114-4697	1	Pump-Injection
1111	99-9637	1	Pipe-Return, Fuel

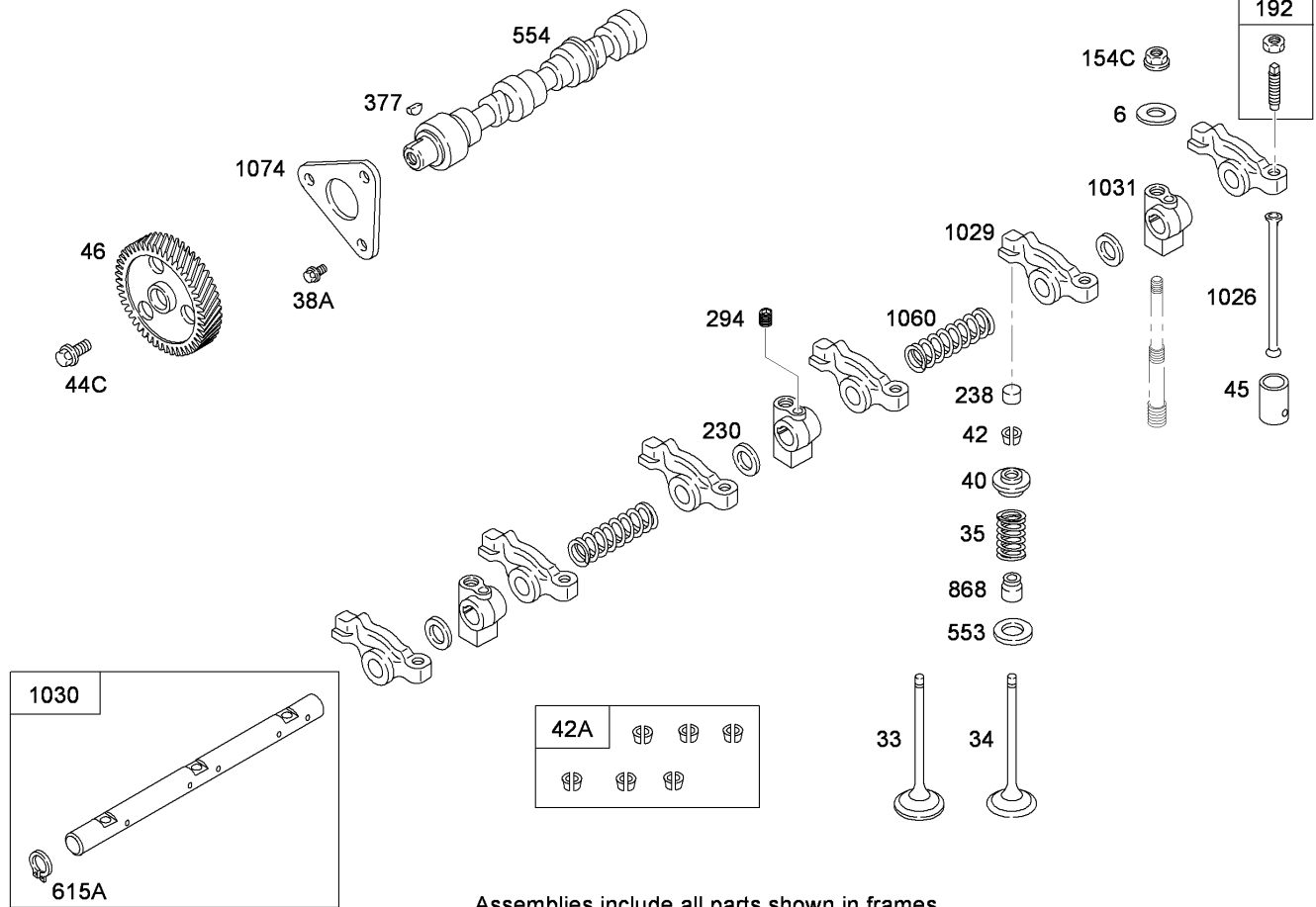

Assemblies include all parts shown in frames

Rocker Arm Assembly

Ref	Part No.	Qty.	Description
6	99-9079	3	Washer-Flat
33	99-9638	3	Valve-Exhaust
34	99-9639	3	Valve-Intake
35	99-9640	6	Spring-Valve
38A	99-9083	3	Screw-Hex
40	99-9084	6	Retainer-Valve
42	99-9086	1	Keeper-Valve (Set)
42A	99-9087	6	Keeper-Valve (Set Of 6)
44C	99-9085	1	Screw-Metric
45	99-9088	6	Tappet-Valve
46	99-9641	1	Gear-Cam
154C	99-9091	3	Nut-Hex, Metric
192	99-9092	6	Adjuster-Arm, Rocker
230	99-9093	3	Washer-Spacer
238	99-9094	6	Cap-Valve
294	99-9090	1	Screw-Metric
377	99-9642	1	Key-Timing
553	99-9096	6	Seat-Spring, Valve
554	99-9097	1	Shaft-Cam
615A	99-9099	2	Retainer
868	99-9643	6	Seal-Valve
1026	99-9103	6	Rod-Push
1029	99-9104	1	Arm-Rocker
1030	99-9106	1	Shaft-Arm, Rocker

Ref	Part No.	Qty.	Description
1031	99-9107	3	Support-Arm, Rocker
1060	99-9108	2	Spring-Shaft, Rocker
1074	99-9109	1	Retainer-Camshaft

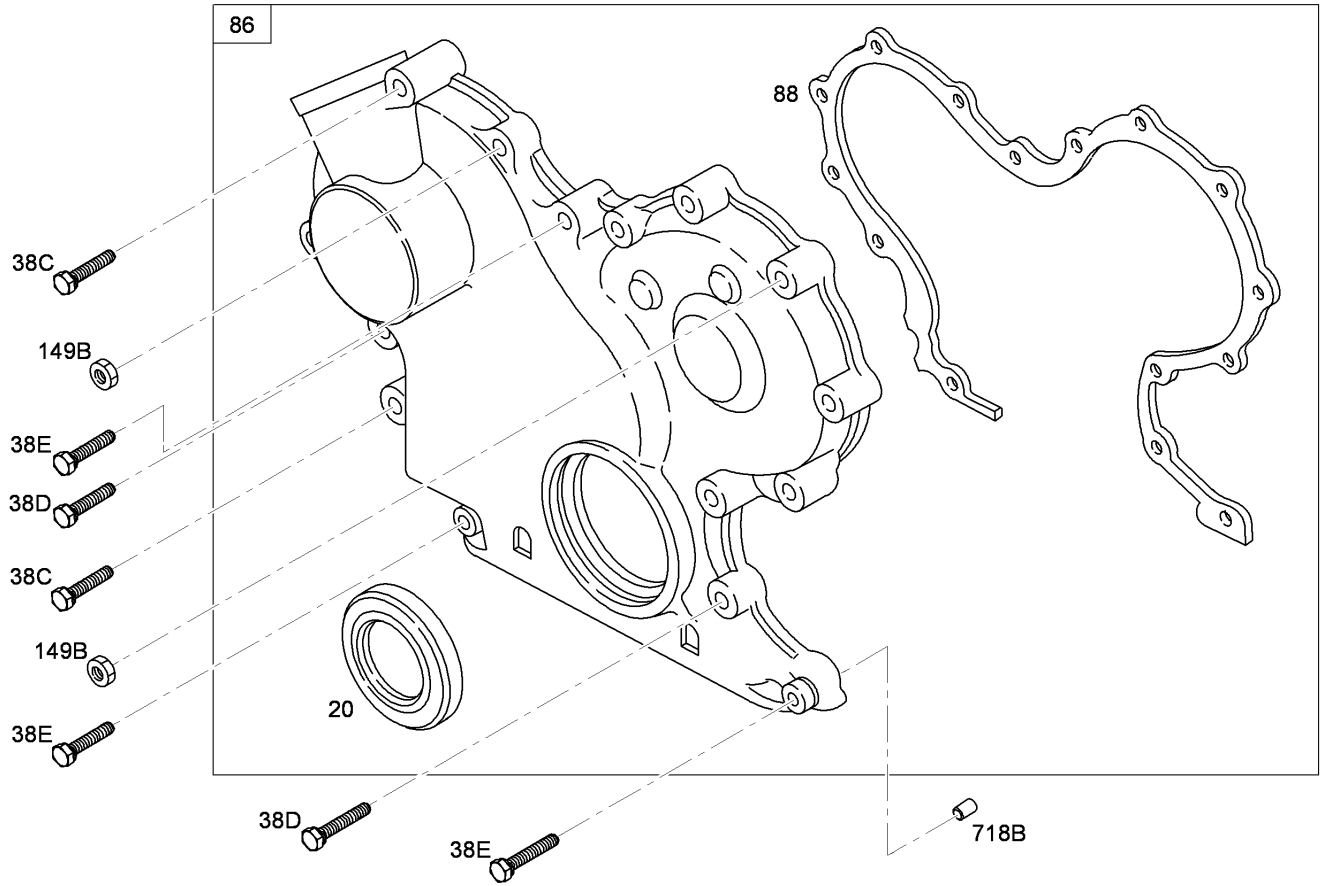

Assemblies include all parts shown in frames

Cover Assembly

Ref	Part No.	Qty.	Description				
20	99-9126	1	Seal-Oil				
38C	99-9651	2	Screw-Hex				
38D	99-9128	9	Screw-Hex				
38E	99-9129	3	Screw-Hex				
86	99-9652	1	Gear Cover ASM				
88	99-9653	1	Gasket-Cover, Gear				
149B	99-9114	2	Nut-Hex, Metric				
718B	99-9014	1	Pin-Locating				

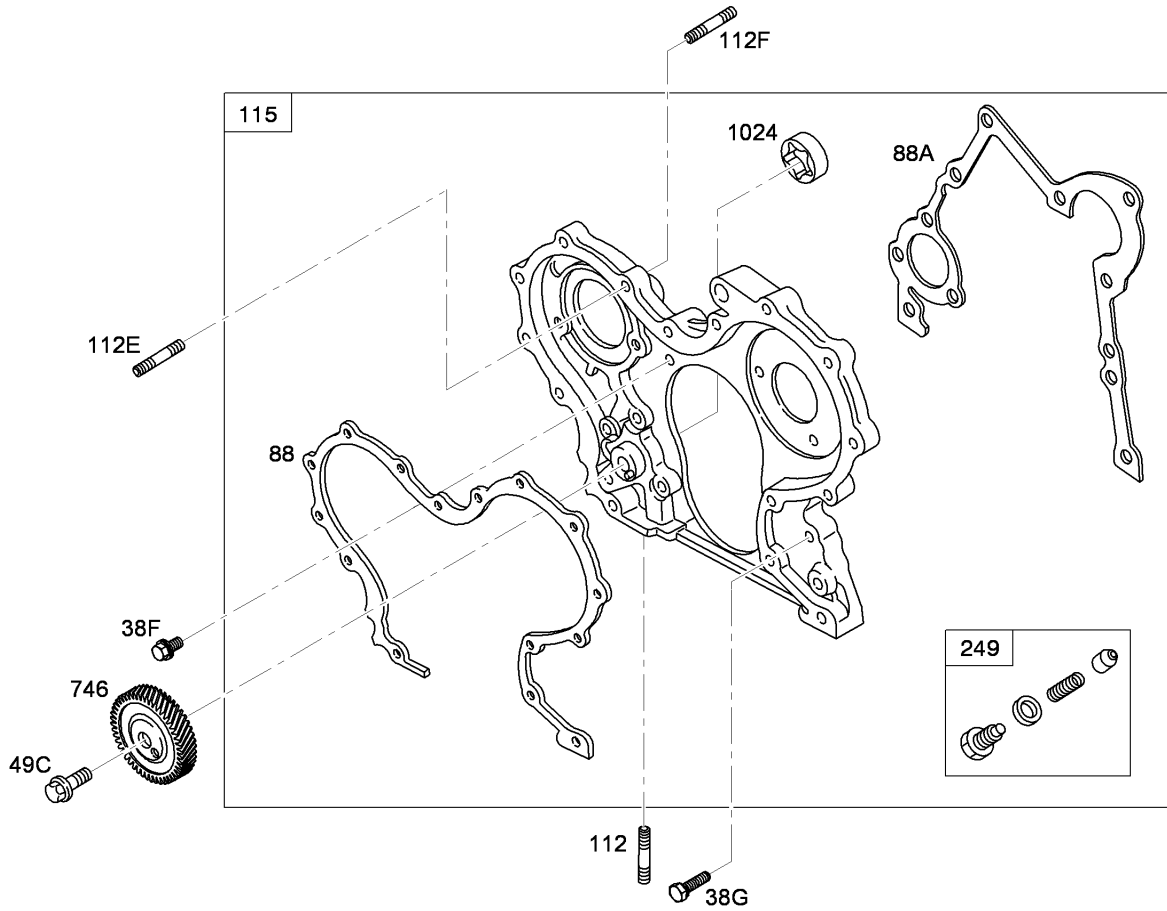

Assemblies include all parts shown in frames

Gear Housing Assembly

Ref	Part No.	Qty.	Description			
38F	99-9134	1	Screw-Hex			
38G	99-9133	4	Screw-Hex			
49C	99-9135	1	Screw-Hex			
88	99-9653	1	Gasket-Cover, Gear			
88A	99-9136	1	Gasket-Cover, Gear			
112	99-9007	1	Stud-Metric			
112E	99-9137	2	Stud-Metric			
112F	99-9654	2	Stud-Metric			
115	99-9655	1	Housing-Gear			
249	99-9142	1	Valve-Relief, Oil			
746	99-9656	1	Gear-Drive			
1024		1	Pump-Oil			

Attachments and Accessories

For 04383 - Greensmaster 3250-D 2-Wheel Drive Traction Unit

Product Name	Model/Part
Turf Evaluator	04399
Three-Wheel Drive Kit	04475
Spiker Kit	04494
Tri-Roller Kit	04495
Dethatching Reel ASM	04496
Leak Detector Kit	04497
Light Kit	04551
Roll-Over Protection Kit	04552
8-Blade DPA Reel Mower	04610
11-Blade DPA Reel Mower	04611
Hose Adapter Kit	100-6430
Oil Cooler Kit	104-7701
Ground-Following Suspension Kit	104-9400
Radiator Screen Kit	105-9766
Wheel Weight Kit	112-0279
MVP Kit	30018
Arm Rest Kit	30707
Screen-Spark Arrestor	94-8157
Tire-Mate, Turf	99-4506

