



## 18-52ZX TimeCutter™ ZX Riding Mower

Model No. 74801 - 230000001 and up.

### Parts Catalog

---

#### Ordering Replacement Parts

To order replacement parts, please supply the part number, the quantity, and the description of each part desired.

#### Understanding Reference Numbers

Each identified part in an illustration has a reference number. The reference number for a part also appears in the parts list, along with other information about the part.

This catalog uses two special reference number formats, one to indicate parts in a service assembly and another to indicate the quantity of a given part in an illustration.

#### Service Assembly Reference Numbers

Parts in service assemblies have reference numbers in the form a:b. The a represents the reference number of the entire service assembly and the b represents a sequential number unique to each part within the service assembly.

For example, a wheel assembly might be identified by reference number 6, the tire by 6:1, the valve by 6:2, and the wheel by 6:3. When you order the assembly identified by reference number 6, you receive all parts identified by reference numbers 6:1, 6:2, and 6:3. However, you may also order any part individually. Reference numbers of this type appear in illustrations and in part lists.

#### Reference Numbers Indicating Quantity

In an illustration, if a reference number indicates more than one part, the reference number has the form nX y. The n represents the quantity of the part, the X is the multiplication symbol, and the y represents the reference number.

For example, in an illustration, the reference number 2X 37 means that two of the parts identified by reference number 37 are indicated.

# Contents

Description	Page	Description	Page
Front Frame Assembly	3	Valve / Camshaft Assembly Kawasaki FH531V-CS07	20
Height-of-Cut Handle and Plate Assembly	4	Lubrication Equipment Assembly Kawasaki FH531V-CS07	21
Main Frame and Seat Assembly	5	Cooling Equipment Assembly Kawasaki FH531V-CS07	22
Fuel Tank and Control Pod Assembly	6	Electric Equipment Assembly Kawasaki FH531V-CS07	23
Parking Brake Assembly	7	Control Equipment Assembly Kawasaki FH531V-CS07	24
Motion Control Assembly	8	Carburetor Assembly Kawasaki FH531V-CS07	25
Hydro and Belt Drive Assembly	9	Air Filter / Muffler Assembly Kawasaki FH531V-CS07	26
Engine and Clutch Assembly	10	Fuel Tank / Fuel Valve Assembly Kawasaki FH531V-CS07	27
Electrical Assembly	11	Starter Assembly Kawasaki FH531V-CS07	28
52in Deck Assembly	12	Label Assembly Kawasaki FH531V-CS07	29
52in Deck Belt Drive and Lift Assembly	13		
RH Hydro Transaxle Assembly No. 107-1708	14		
LH Hydro Transaxle Assembly No. 107-1709	16		
Cylinder / Crankcase Assembly Kawasaki FH531V-CS07	18		
Piston / Crankshaft Assembly Kawasaki FH531V-CS07	19		

## Part Description Abbreviations

Part descriptions in this catalog may include the following abbreviations.

AR. .... as required	HYD. .... hydraulic
ASM. .... assembly	LH. .... left hand
BBC. .... blade brake clutch	NI. .... nylon insert
CARR. .... carriage	NPTF. .... national pipe thread fine
DEG. .... degrees	PFH. .... phillips flat head
EXT. .... external	PPH. .... phillips pan head
FH. .... flat head	PPHTF. .... phillips pan head thread forming
GA. .... gauge	PRH. .... phillips round head
HD. .... heavy-duty	PTH. .... phillips truss head
HF. .... hex flange	PTO. .... power-take-off
HH. .... hex head	RH. .... right hand
HHF. .... hex head flange	ROPS. .... roll-over protection system
HHFTF. .... hex head flange thread forming	SFH. .... slotted fillister head
HJ. .... hex jam	SHH. .... slotted hex head
HLH. .... hex lag head	SHWH. .... slotted hex washer head
HOC. .... height-of-cut	SPH. .... slotted pan head
HSBH. .... hex socket button head	SQH. .... square head
HSFH. .... hex socket flat head	SRH. .... slotted round head
HSH. .... hex socket head	STD. .... standard
HWH. .... hex washer head	TAP. .... self tapping
HWHTF. .... hex washer head thread forming	TTH. .... torx truss head

## Footnotes

- ❶ Not illustrated
- ❷ Not serviced separately
- ❸ Obtain from your local Kawasaki dealer

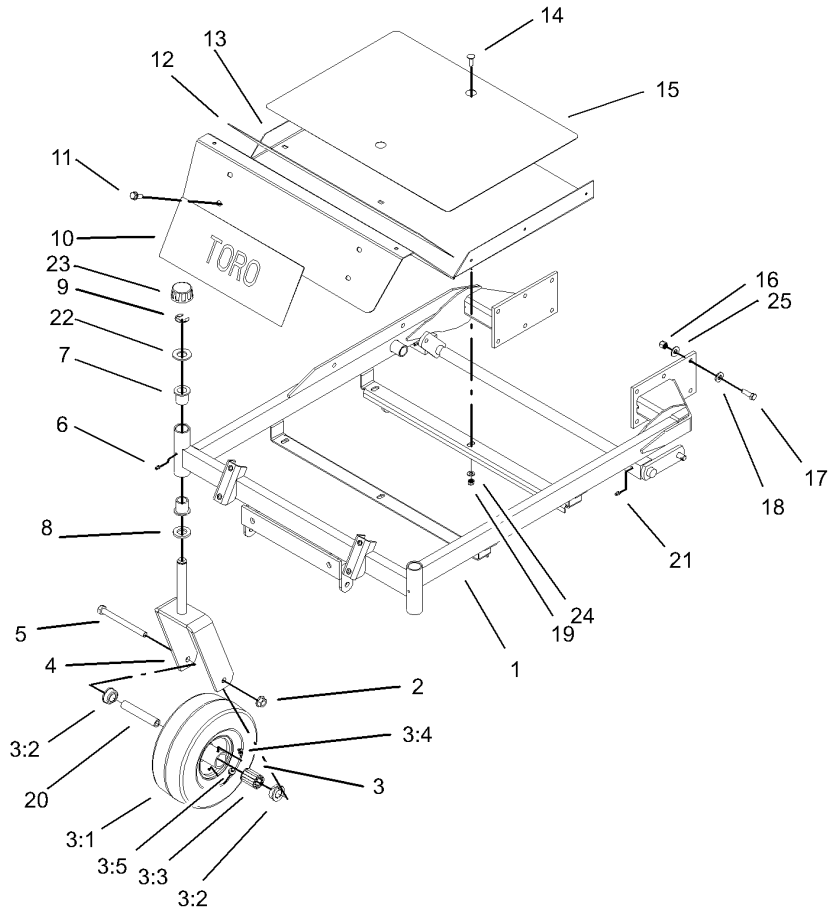

### Front Frame Assembly

Ref	Part No.	Qty.	Description
1	100-7357-01	1	Carrier Frame ASM
2	32128-23	2	Nut-HF
3	100-7364	2	Caster Wheel ASM
3:1	105-1943	1	Tire
3:2	62-5580	2	Bearing-Outside
3:3	83-4740	1	Bearing
3:4	302-11	1	Fitting-Lube, 45 DEG
3:5	232-27	1	Stem-Valve
①	93-4244	1	Tube-Inner (W/Valve)
4	100-7363-01	2	Caster Fork ASM
5	325-22	2	Screw-HH
6	302-5	2	Fitting-Grease
7	1-303514	4	Bearing-Flanged
8	1-513338	2	Washer-Flat
9	32151-103	2	Ring-Snap
10	67-7320	1	Decal
11	66-9300	4	Screw-HF
12	104-3639	1	Pad-Skid, Anti
13	100-7386-03	1	Floorpan
14	3230-28	6	Screw-CARR
15	104-3640	1	Pad-Skid, Anti
16	3296-39	12	Nut-Lock, NI
17	323-7	12	Screw-HH
18	98-5975	12	Washer-Belleville

Ref	Part No.	Qty.	Description
19	3296-29	6	Nut-Lock, NI
20	104-3667	2	Spanner-Wheel
21	302-19	2	Fitting-Grease
22	104-8076	2	Washer
23	61-9780	2	Cap-Hub
24	3256-23	6	Washer-Flat
25	1-809107	12	Washer-Hardened

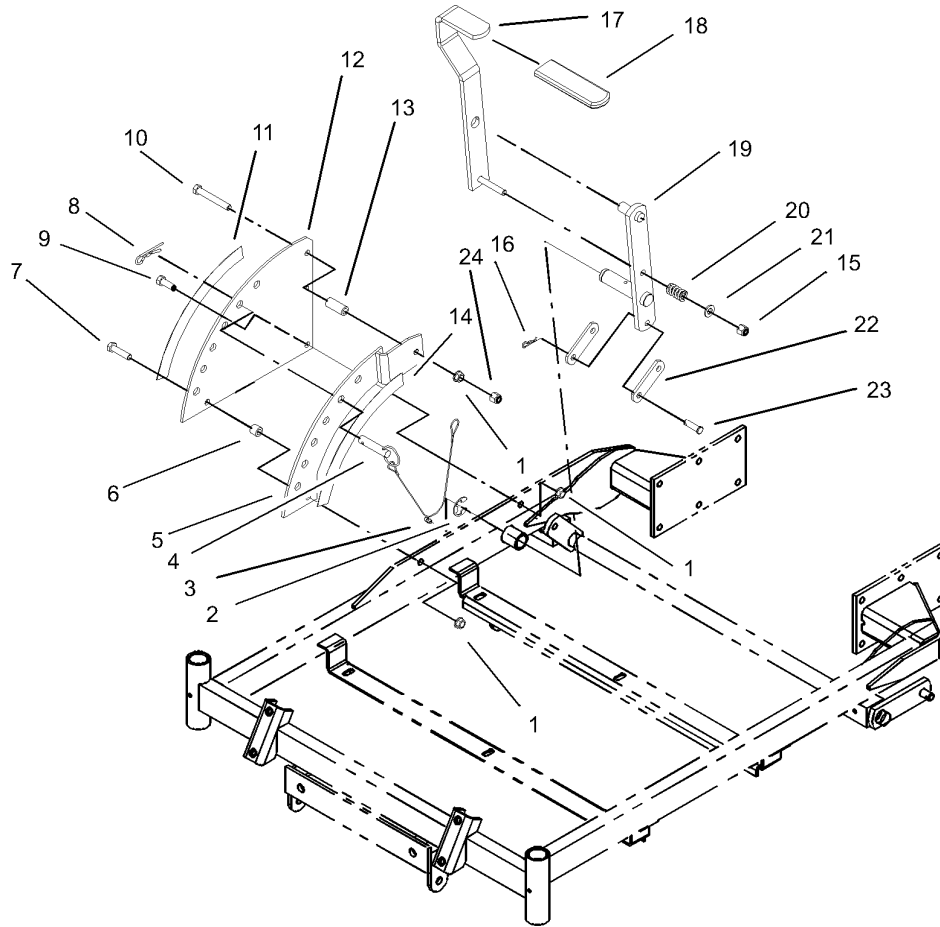

## Height-of-Cut Handle and Plate Assembly

Ref	Part No.	Qty.	Description
1	3290-357	3	Nut-HHF, Whiz
2	32151-103	1	Ring-Snap
3	302-5	1	Fitting-Grease
4	104-3678	1	Pin-Hitch
5	100-7335-01	1	Plate-Lift
6	1-413088	1	Bushing-Lever, Lift
7	323-8	1	Screw-HH
8	1-806005	1	Pin-Hair
9	323-6	1	Screw-HH
10	323-13	1	Screw-HH
11	104-3641	1	Decal-Deck Height, Outer
12	100-7384-01	1	Plate-Deck Lift
13	1-633082	1	Bushing-Lever, Lift
14	104-8032	1	Decal-Deck Height, Inner
15	3296-39	1	Nut-Lock, NI
16	1-806003	2	Pin-Hair
17	1-652023-03	1	Lever-Lift
18	1-633295	1	Grip-Lever, Lift
19	1-652027-03	1	Arm-Deck, Lift
20	1-633325	1	Spring-Compression
21	3256-24	1	Washer-Flat
22	1-633068	2	Arm-Lift, Deck
23	283-2	2	Pin-Clevis
24	32128-21	1	Nut-HF

--	--	--	--

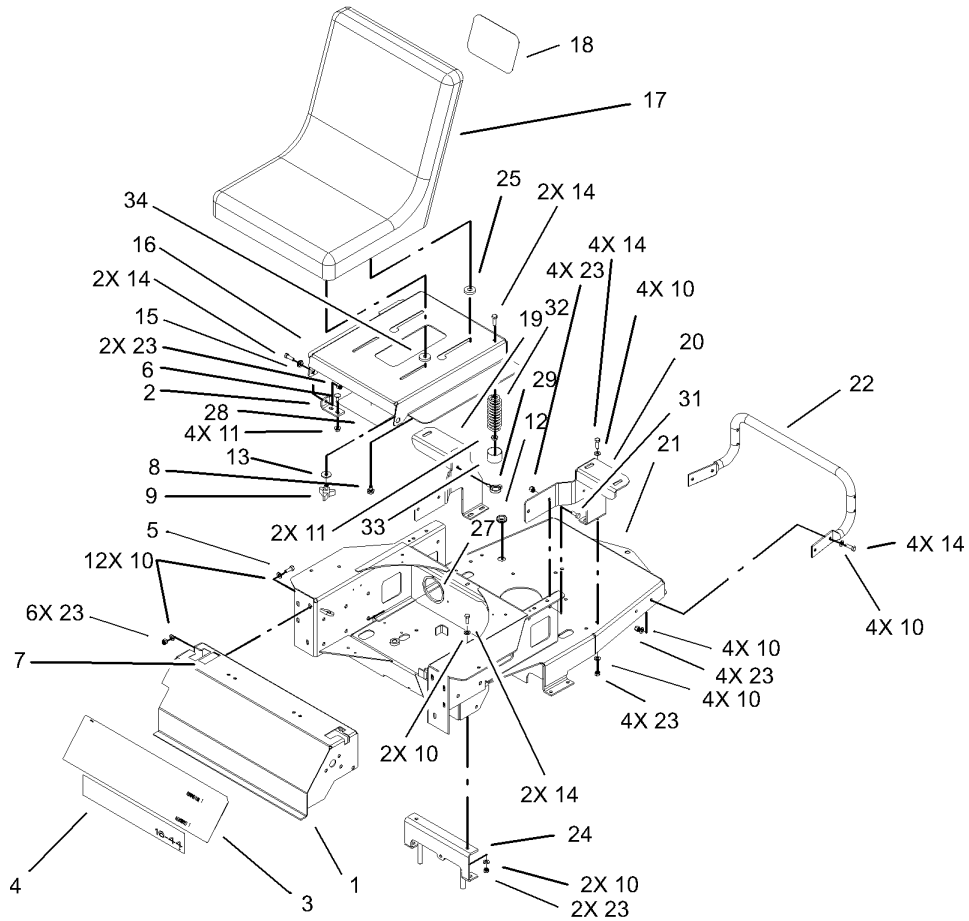

## Main Frame and Seat Assembly

Ref	Part No.	Qty.	Description
1	104-8040-03	1	Console
2	104-8057-03	2	Bracket-Pivot
3	104-8014	1	Decal-Console
4	106-2208	1	Decal
5	322-4	6	Screw-HH
6	104-8049	4	Screw-CARR
7	1-633354	2	Decal-Control, Motion
8	92-6986	2	Bolt-Shoulder
9	106-2240	2	Knob
10	3256-23	32	Washer-Flat
11	32128-25	6	Nut-HF
12	237-124	1	Grommet
13	5-4460	2	Washer-Pivot
14	322-5	14	Screw-HH
15	105503	2	Bushing
16	104-8058-03	1	Pan-Seat
17	106-2221	1	Seat
18	93-7340	1	Decal
19	100-7376-01	1	Bracket-RH
20	100-7368-01	1	Bracket-LH
21	105-7018-01	1	Frame-Rear
22	100-7332-03	1	Rod-Support, Rear
23	3296-29	22	Nut-Lock, NI
24	105-6987-03	1	Bracket

Ref	Part No.	Qty.	Description
25	92-6750	2	Spacer-Nylon
27	105-1854	1	Cover-Conduit
28	104-8088	1	Decal-Service
29	105-1853	2	Clamp-Hose
31	322-3	4	Screw-HH
32	92-7054	2	Spring-Compression
33	701178	2	Cap-Protector
34	109989	2	Spacer-Nylon

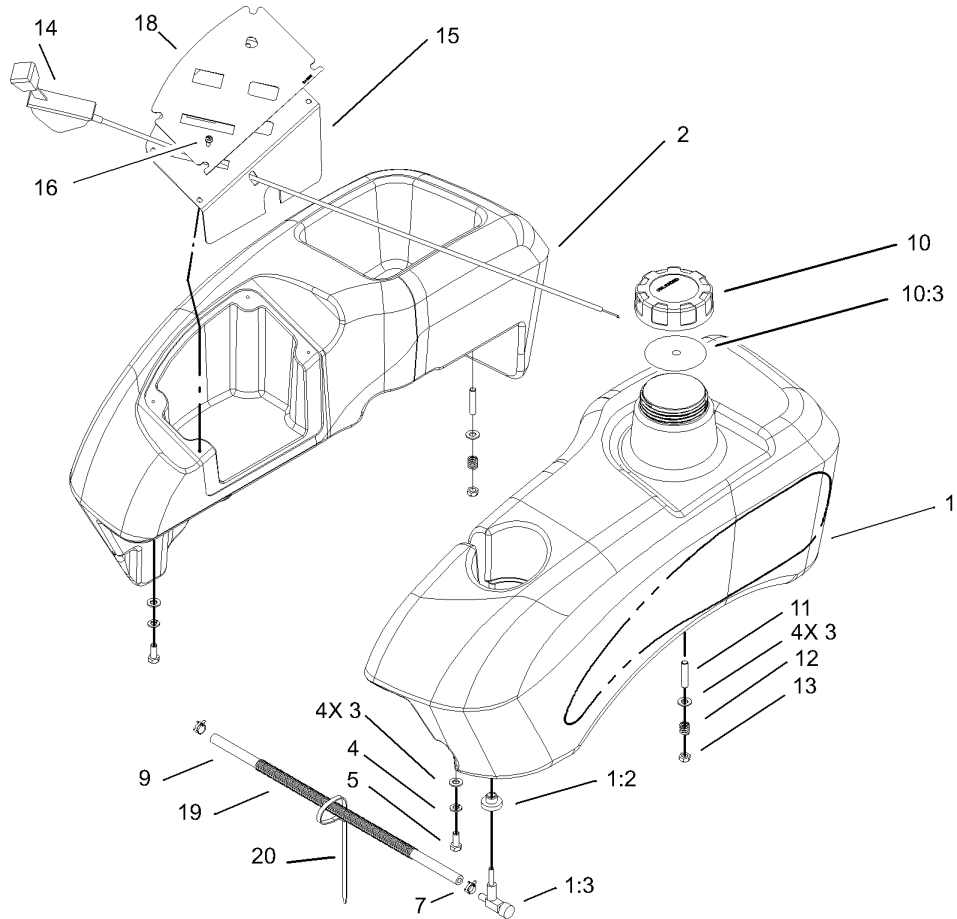

## Fuel Tank and Control Pod Assembly

Ref	Part No.	Qty.	Description
1	105-3494	1	Fuel Tank ASM
1:2	46-6560	1	Bushing
1:3	104048	1	Valve-Fuel
2	105-1918	1	Tank-Console
3	3256-23	8	Washer-Flat
4	3253-4	4	Washer-Lock
5	322-3	4	Screw-HH
7	2412-98	2	Clamp
9	104-8060	1	Hose-Fuel
10	88-3980	1	Gas Cap ASM
10:3	88-4010	1	Gasket-Cap, Gas
11	1-633023	4	Stud
12	1-633349	4	Spring-Tank, Fuel
13	3296-47	4	Nut-Lock, NI
14	104-8081	1	Cable-Throttle
15	104-3664-03	1	Panel-Control
16	3250-14	4	Screw-PPH
18	104-8009	1	Decal-Panel, Control
19	105-1854	1	Cover-Conduit
20	614249	1	Strap-Tie

--	--	--	--

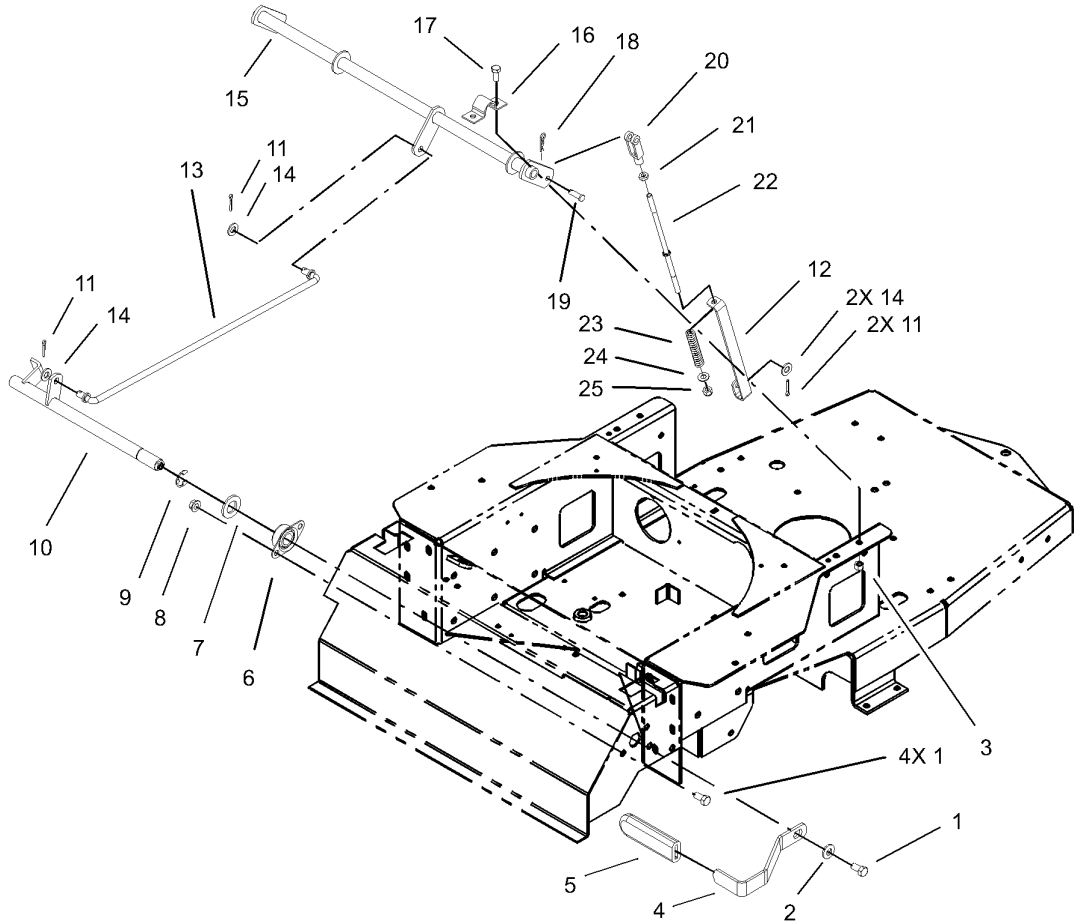

## Parking Brake Assembly

Ref	Part No.	Qty.	Description
1	323-4	5	Screw-HH
2	98-5975	1	Washer-Belleville
3	3296-29	4	Nut-Lock, NI
4	100-7346-03	1	Handle-Brake, Park
5	1-633268	1	Grip-Lever, Brake
6	1-633102	2	Bearing-Flange, Side
7	1-303007	1	Washer
8	3290-357	4	Nut-HHF, Whiz
9	32151-48	1	E-Ring
10	100-7318	1	Brake Shaft ASM
11	3272-10	4	Pin-Cotter
12	104-3675	2	Bracket-Spring, Brake
13	104-8046	1	Rod-Brake, Upper
14	3256-24	4	Washer-Flat
15	104-3670-03	1	Shaft-Brake
16	88-4730	2	Clamp-Pivot, HOC
17	322-3	4	Screw-HH
18	1-806003	2	Pin-Hair
19	1-808280	2	Pin-Clevis
20	1-303105	2	Yoke-Adjustable
21	3219-2	2	Nut-Hex
22	104-3674	2	Rod-Brake, Upper
23	38-4520	2	Spring
24	3256-23	2	Washer-Flat

Ref	Part No.	Qty.	Description
25	3296-4	2	Nut-Lock

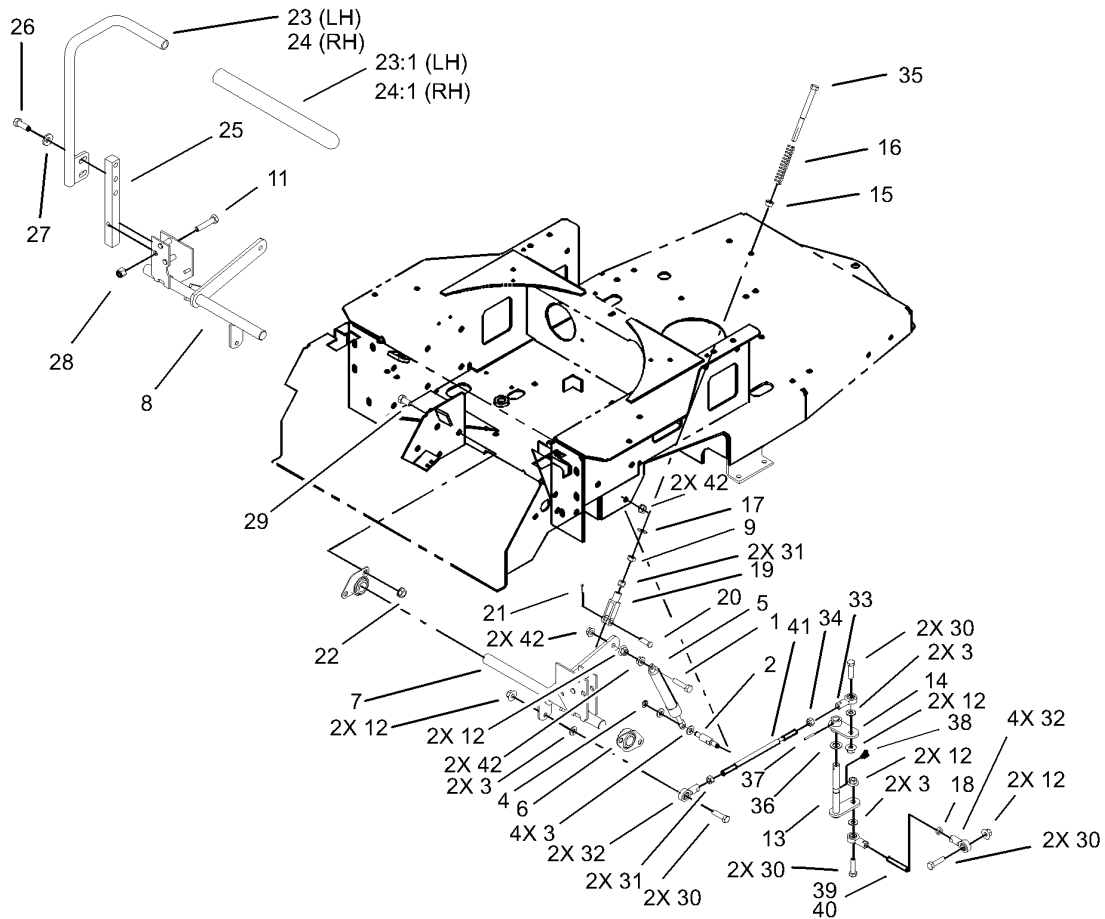

## Motion Control Assembly

Ref	Part No.	Qty.	Description
1	1-403180	2	Screw-HH
2	1-653316	2	Pin-Damper
3	3256-23	10	Washer-Flat
4	32120-35	2	Ring-Retaining, EXT
5	103-2913	2	Damper-Control, Motion
6	1-633102	4	Bearing-Flange, Side
7	100-7341	1	Bracket-Motion Control, LH
8	100-7340	1	Bracket-Motion Control, RH
9	3296-4	2	Nut-Lock
11	323-9	2	Screw-HH
12	32128-20	10	Nut-HF
13	100-7311	2	Pivot ASM
14	100-7313	2	Pivot Plate ASM
15	1-603735	2	Bushing-Flanged
16	1-603807	2	Spring-Return, Neutral
17	3256-2	2	Washer-Flat
18	3220-2	2	Nut-Jam
19	1-303105	2	Yoke-Adjustable
20	1-808280	2	Pin-Clevis
21	3272-5	2	Pin-Cotter
22	3290-357	6	Nut-HHF, Whiz
23	103-0631	1	LH Lever ASM
23:1	1-633257	1	Grip-Control, Motion
24	103-0632	1	RH Lever ASM

Ref	Part No.	Qty.	Description
24:1	1-633257	1	Grip-Control, Motion
25	103-0407	2	Arm-Shaft, Control
26	323-6	4	Screw-HH
27	98-5975	4	Washer-Belleville
28	3296-39	2	Nut-Lock, NI
29	323-4	6	Screw-HH
30	322-5	8	Screw-HH
31	3219-2	4	Nut-Hex
32	1-543017	6	Balljoint-RH
33	1-633152	2	Balljoint-LH
34	1-804524	2	Nut
35	1-603737	2	Bolt-Return, Neutral
36	100-7336	2	Washer
37	933156	2	Pin-Roll
38	302-11	2	Fitting-Lube, 45 DEG
39	104-3606	1	Linkage-Lower, RH
40	104-3607	1	Linkage-Lower, LH
41	104-3605	2	Linkage-Upper
42	32128-25	6	Nut-HF

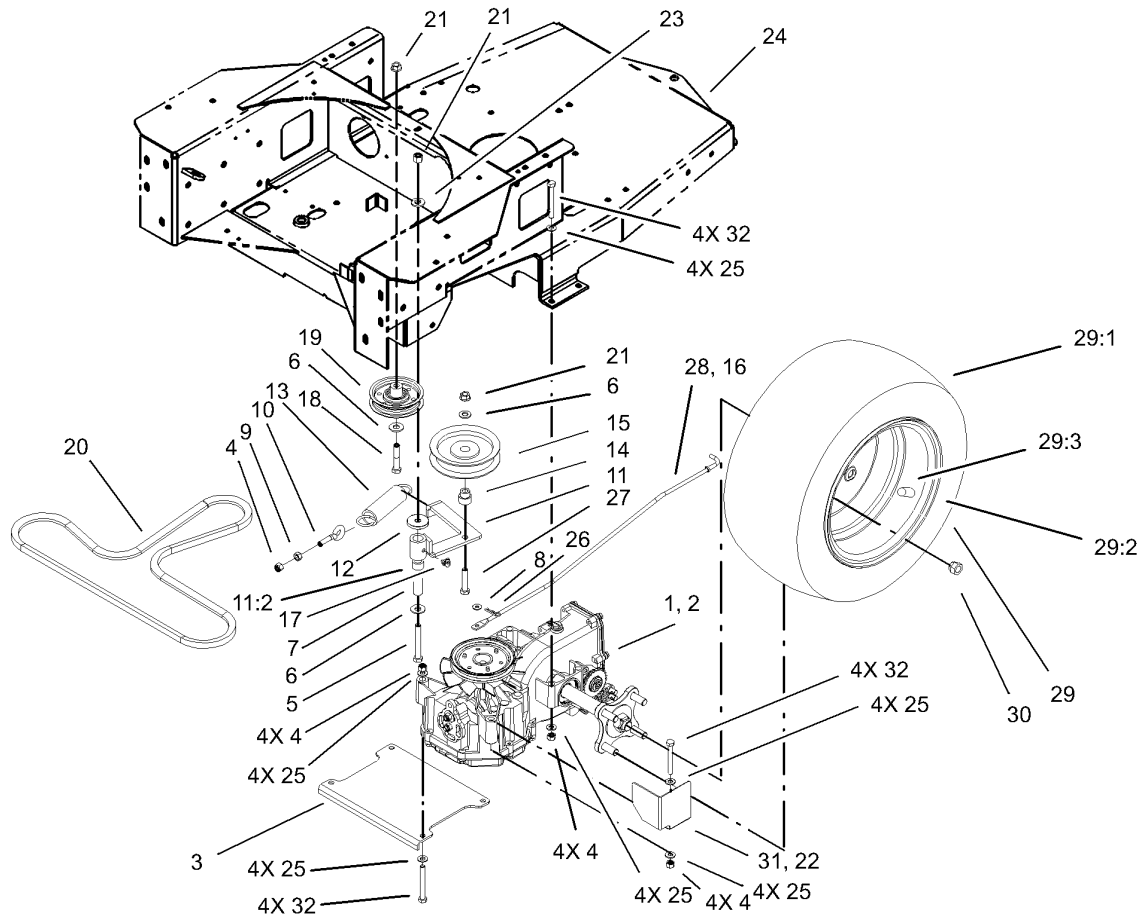

## Hydro and Belt Drive Assembly

Ref	Part No.	Qty.	Description
1	107-1709	1	Hydro-LH
2	107-1708	1	Hydro-RH
3	100-7317-03	1	Plate-Hydro, Lower
4	3296-29	13	Nut-Lock, NI
5	323-13	1	Screw-HH
6	3256-4	3	Washer-Flat
7	1-603044	1	Bushing
8	3256-1	2	Washer-Flat
9	32128-20	1	Nut-HF
10	55-9420	1	Bolt-Eye
11	104-3614	1	Idler Arm ASM
11:2	1-513034	2	Sleeve-Bearing
12	104-8005	1	Spacer
13	1-603414	1	Spring-Extension
14	1-603496	1	Bushing-Idler
15	1-603843	1	Pulley-Idler
16	104-3668	1	Rod-RH
17	302-40	1	Fitting-Grease
18	323-10	1	Screw-HH
19	104-3630	1	Pulley-Idler
20	104-3622	1	Belt-V
21	32128-21	3	Nut-HF
22	104-8033-03	1	Guard-Fan, LH
23	98-5975	1	Washer-Belleville

Ref	Part No.	Qty.	Description
24	104-8008	1	Decal-Transport
25	3256-23	24	Washer-Flat
26	1-806003	2	Pin-Hair
27	323-9	1	Screw-HH
28	104-3669	1	Rod-LH
29		2	ASM-Wheel And Tire
29:1	105-1945	1	Tire
29:2	105-1947	1	Wheel
29:3	232-27	1	Stem-Valve
30	242-50	8	Nut-Lug
31	104-8013-03	1	Guard-Fan, RH
32	322-13	12	Screw-HH

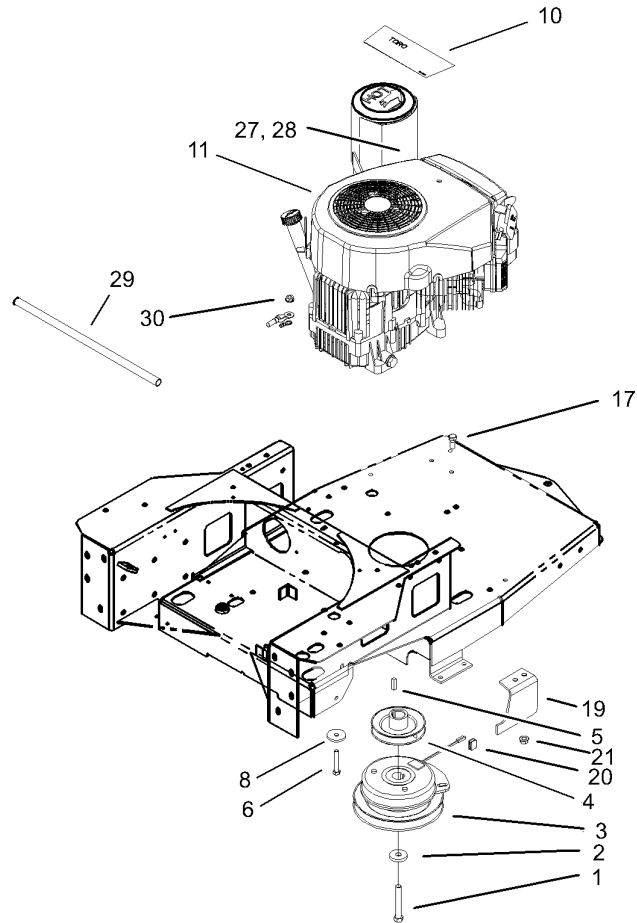

## Engine and Clutch Assembly

Ref	Part No.	Qty.	Description
1	3212-12	1	Screw-HH
2	112843	1	Washer
3	104-3624	1	Clutch
4	100-7314	1	Pump Drive Pulley ASM
5	5-7280	1	Key
6	322-7	4	Screw-HH
8	62-7190	4	Spacer-Steel
10	106-2204	1	Decal-Engine Kawasaki
11		1	Engine-18 Hp V-Twin Kawasaki Model No. FH531V-Cs07
17	323-4	2	Screw-HH
19	104-3613-03	1	Stop-Clutch
20	98-5023	1	Bumper
21	32128-21	2	Nut-HF
27	100-6467	1	Muffler
28	100-6468	1	Clamp-Muffler
29	106-7022	1	Tube-Drain, Oil
30	32128-25	4	Nut-HF

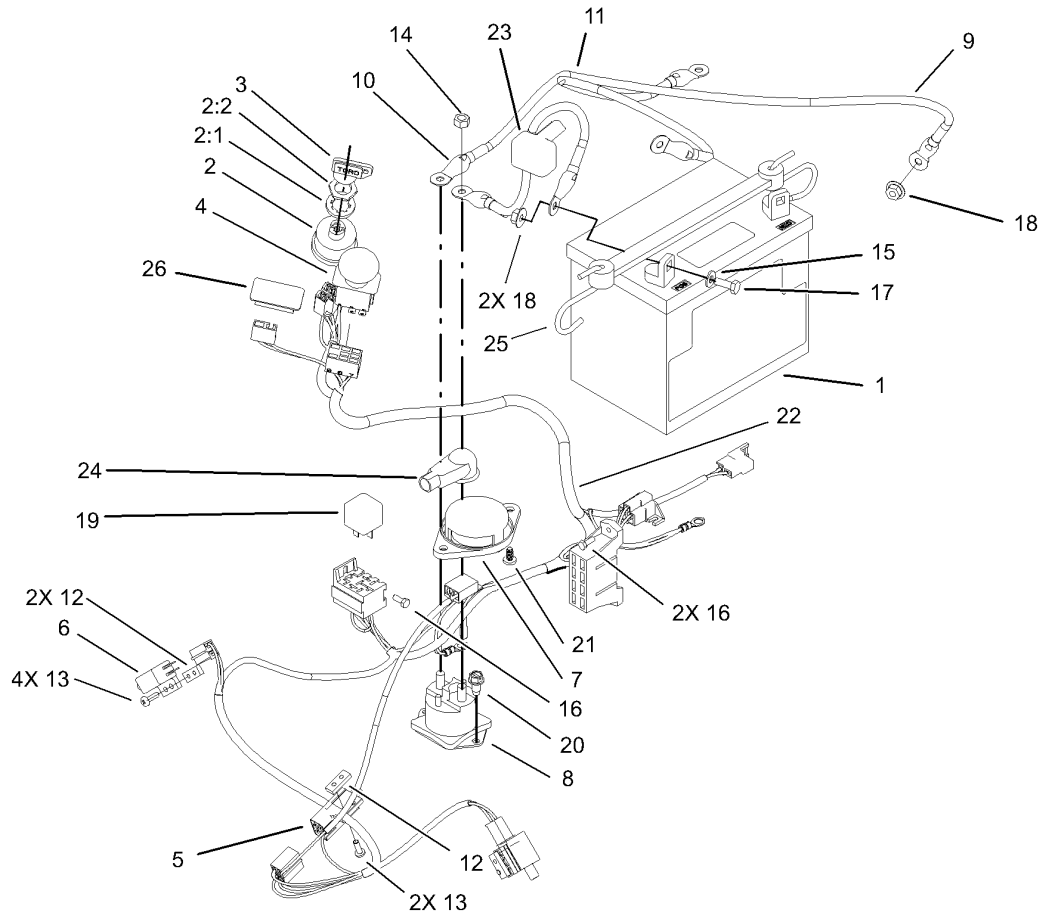

## Electrical Assembly

Ref	Part No.	Qty.	Description
1	104-2491	1	Battery-Dry
2	88-9830	1	Key Switch ASM
2:1	3254-5	1	Washer-Tooth
2:2	218-461	1	Nut-HH
3	63-8360	1	Key-Ignition
4	95-7489	1	Switch-PTO
5	86-4690	1	Switch-Interlock
6	65-7410	2	Switch-Pole, Single
7	105-6959	1	Switch-Seat
8	28-4210	1	Solenoid
9	28-3891	1	Wire-Solenoid/Starter
10	93-1189	1	Wire ASM
11	93-0324	1	Cable
12	1-633181	3	Plate-Tapped
13	32144-8	6	Screw-PPHTF
14	32149-1	2	Nut-Keps
15	3256-22	2	Washer-Flat
16	32144-1	3	Screw-Taptite
17	321-4	2	Screw-HH
18	32128-33	3	Nut-HF
19	98-7249	1	Relay
20	46-8560	2	Screw-HHF
21	105-6968	2	Screw-Seat, Switch
22	105-1934	1	Harness-Wire Kawasaki V-Twin

Ref	Part No.	Qty.	Description
●22:1	109102	1	Fuse-25 Amp
●22:2	109103	1	Fuse-30 Amp
23	28-8080	1	Boot-Terminal
24	93-3190	1	Boot-Insulator, Terminal
25	104-2466	1	Holddown-Battery
26	99-7420	1	Plug-Hole

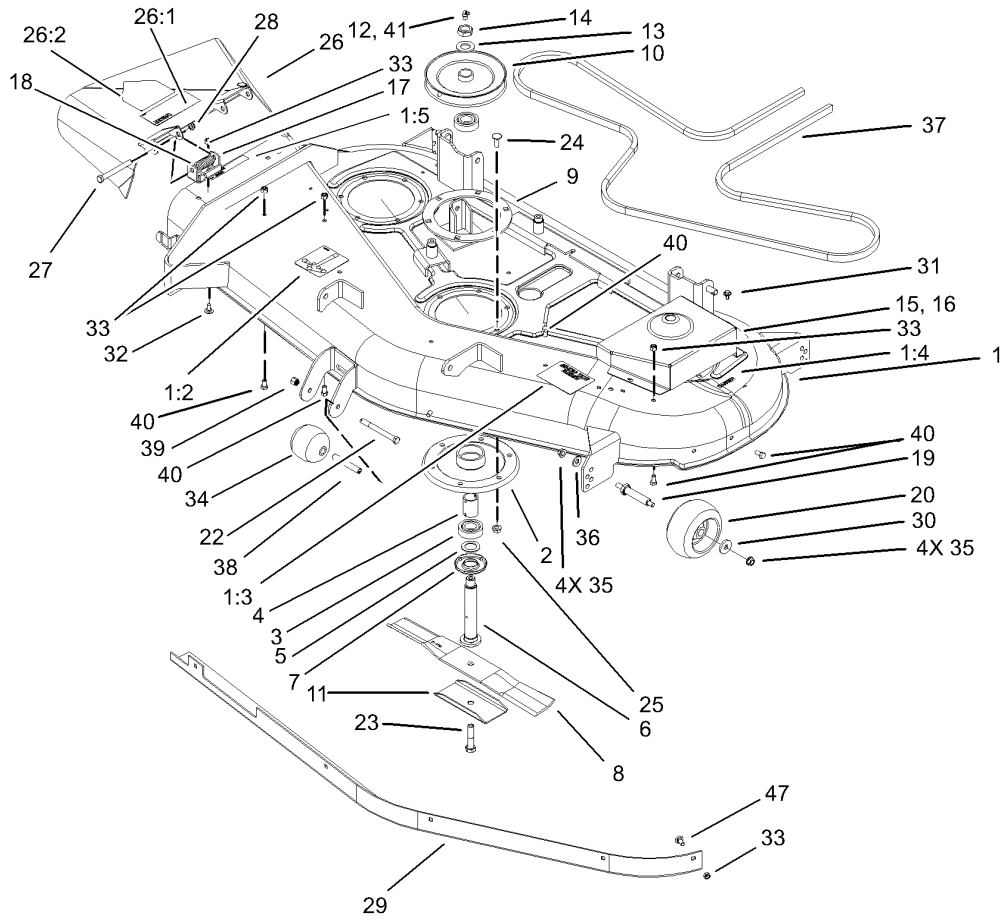

## 52in Deck Assembly

Ref	Part No.	Qty.	Description
1	106-7000	1	Deck ASM
1:2	99-3943	1	Decal-Routing, Belt
1:3	98-3798	1	Decal-Wheel, Gage
1:4	92-7108	1	Decal-Danger
1:5	92-7109	1	Decal-Caution
2	79-2480-03	3	Housing-Spindle
3	113514	6	Bearing-Ball
4	79-1890	3	Spacer-Bearing
5	120860	3	Washer-Wheel
6	79-1910	3	Shaft-Spindle
7	79-1920	3	Shield-Bearing
8	27-0990-03	3	Blade-18 Inch
9	27-7680-01	3	Ring-Deck Support
10	100-7320	3	Pulley/Hub ASM
11	92-9820	3	Stiffener-Blade
12	302-2	2	Fitting-Grease
13	3256-28	3	Washer-Flat
14	3220-7	3	Nut-Jam
15	104-3685-01	1	Cover-Belt, LH
16	104-3684-01	1	Cover-Belt, RH
17	29-5590-03	2	Bracket-Pivot
18	40-6230	2	Spring
19	99-2842	4	Spacer
20	68-2730	4	Wheel-Gage

Ref	Part No.	Qty.	Description
22	323-16	1	Screw-HH
23	44-2200	3	Screw-Blade
24	3231-22	18	Screw-CARR
25	32128-21	18	Nut-HF
26	94-1580	1	Deflector ASM
26:1	92-7108	1	Decal-Danger
26:2	93-1122	1	Decal-Danger
27	3211-15	2	Screw-HH
28	3296-5	2	Nut-Lock
29	67-2150-01	1	Baffle
30	1-373034	4	Washer
31	46-8560	5	Screw-HHF
32	3230-18	4	Screw-CARR
33	3296-29	16	Nut-Lock, NI
34	29-4820	1	Roller
35	3290-357	8	Nut-HHF, Whiz
36	98-5975	4	Washer-Belleville
37	99-3904	1	Belt-Deck
38	94-2500	1	Tube-Spacer, Wheel
39	3296-39	1	Nut-Lock, NI
40	322-2	7	Screw-HH
41	302-33	1	Fitting-Grease
47	3230-20	5	Screw-CARR

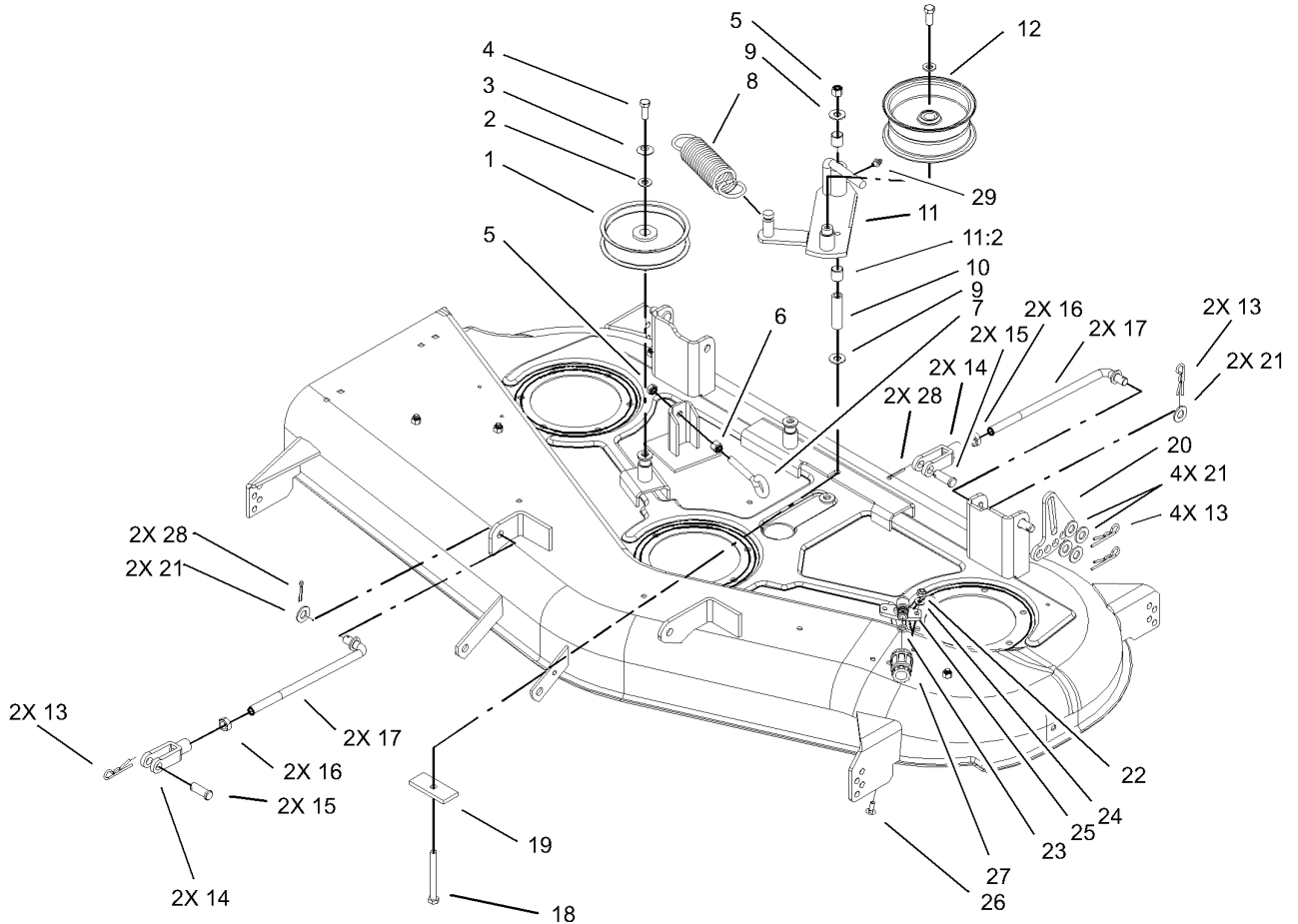

## 52in Deck Belt Drive and Lift Assembly

Ref	Part No.	Qty.	Description
1	1-613098	2	Pulley-Idler
2	3256-24	3	Washer-Flat
3	98-5975	3	Washer-Belleville
4	323-6	3	Screw-HH
5	3296-39	2	Nut-Lock, NI
6	3217-7	1	Nut-Hex
7	94-2547	1	Bolt-Eye
8	1-633151	1	Spring-Extension
9	1-809107	2	Washer-Hardened
10	1-603384	1	Bushing-Pivot, Idler
11	99-3879	1	Idler Arm ASM
11:2	1-513034	2	Sleeve-Bearing
12	1-413099	1	Pulley-Idler
13	1-806005	8	Pin-Hair
14	100-7338	4	Clevis
15	104-3634	4	Pin-Clevis
16	3220-5	4	Nut-Jam
17	104-8047	4	Rod-Trunion
18	1-800805	1	Screw-HH
19	104-8037-01	1	Plate-Bolt, Retainer
20	104-3699-01	2	Link-HOC, Adjusting
21	3256-26	12	Washer-Flat
22	3296-16	2	Nut-Lock, NI
23	46-6290	1	O-Ring

Ref	Part No.	Qty.	Description
24	3256-1	2	Washer-Flat
25	95-2747	1	Fitting-Washout
26	3229-1	2	Screw-CARR
27	95-3270	1	Connector-Hose
28	3272-10	4	Pin-Cotter
29	302-19	1	Fitting-Grease

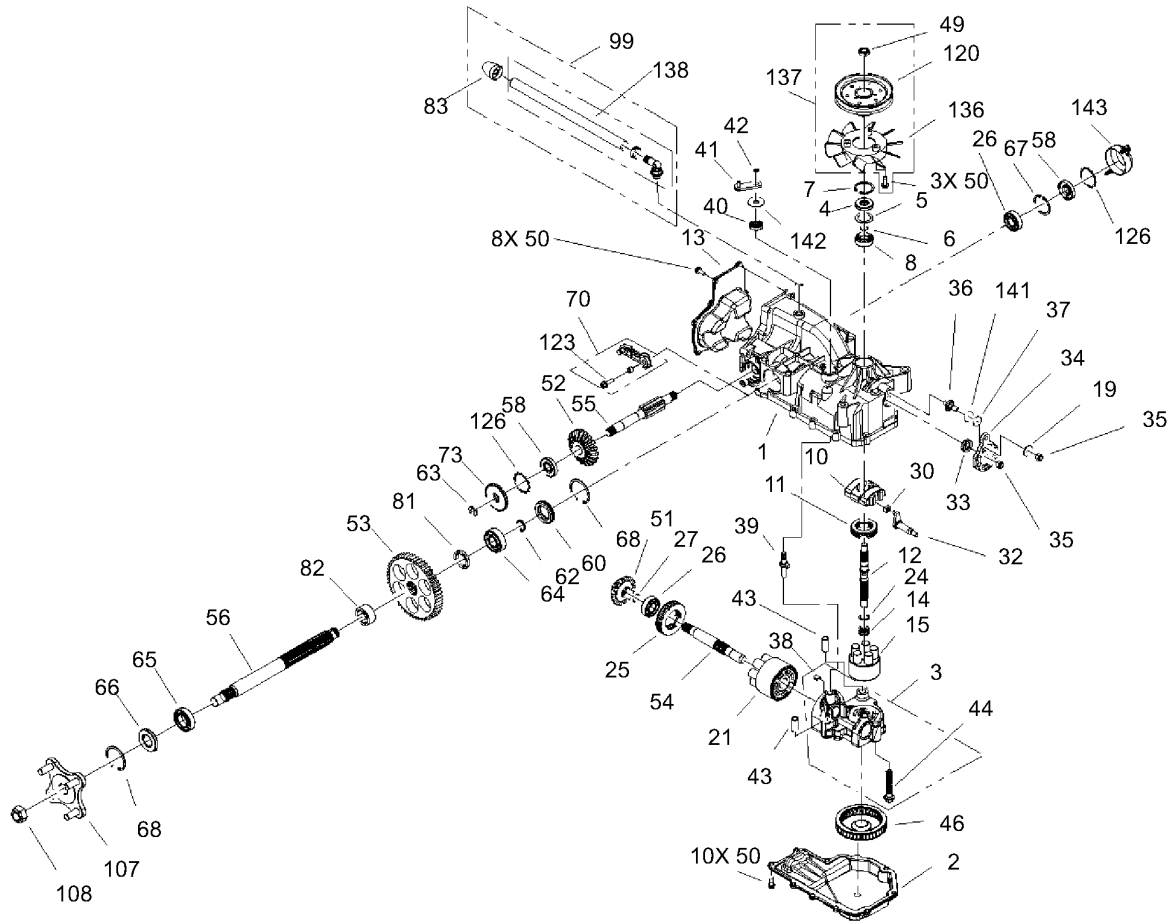

## RH Hydro Transaxle Assembly No. 107-1708

Ref	Part No.	Qty.	Description
1	107-1700	1	Main Housing Kit
2	105-1868	1	Housing-Lower
3	105-1869	1	Center Section Kit ASM
4	92-6543	1	Seal-Lip
5	104-2104	1	Spacer
6	94-1902	1	Ring-Wire, Retaining
7	94-1903	1	Ring-Retaining
8	94-1904	1	Bearing-Shaft, Ball
10	94-1907	1	Swashplate-Variable
11	94-6922	1	Bearing-Thrust
12	104-5067	1	Shaft-Input
13	105-1870	1	Cover-Back
14	94-1936	1	Spring-Block
15	104-2106	1	Cylinder Block ASM
19	5-4460	1	Washer-Pivot
21	94-1913	1	Cylinder Block ASM
24	94-1937	1	Washer-Block, Thrust
25	94-6923	1	Bearing-Thrust
26	104-5311	2	Bearing-Ball
27	104-5307	1	Ring-Retaining
30	94-1910	1	Guide-Slot
31	104-2112	1	Trunnion ASM
33	92-6544	1	Seal-Lip
34	105-1871	1	Arm-Control

Ref	Part No.	Qty.	Description
35	105-1872	2	Nut
36	104-2116	1	Stud
37	105-1873	1	Puck-Friction
38	94-6925	1	Plate-Bypass
39	94-1914	1	Actuator-Bypass
40	92-6545	1	Seal-Lip
41	104-2117	1	Arm-Bypass
42	936109	1	Ring-Retaining
43	94-1927	2	Pin
44	94-6926	3	Bolt
46	105-1874	1	Filter
49	105-1875	1	Nut-Lock
50	104-2120	21	Screw
51	105-1876	1	Gear-Bevel, 14T
52	105-1877	1	Gear-Bevel, 19T
53	105-1878	1	Gear-Bevel, 53T
54	105-1879	1	Shaft-Motor
55	105-1880	1	Shaft-Brake
56	105-1881	1	Shaft-Axle
58	104-5310	2	Seal-Lip
60	105-1882	1	Plug-Side Seal
62	105-1883	1	Ring-Axle, Retaining
63	105-1884	1	Ring-Retaining
64	105-1885	1	Bearing-Ball



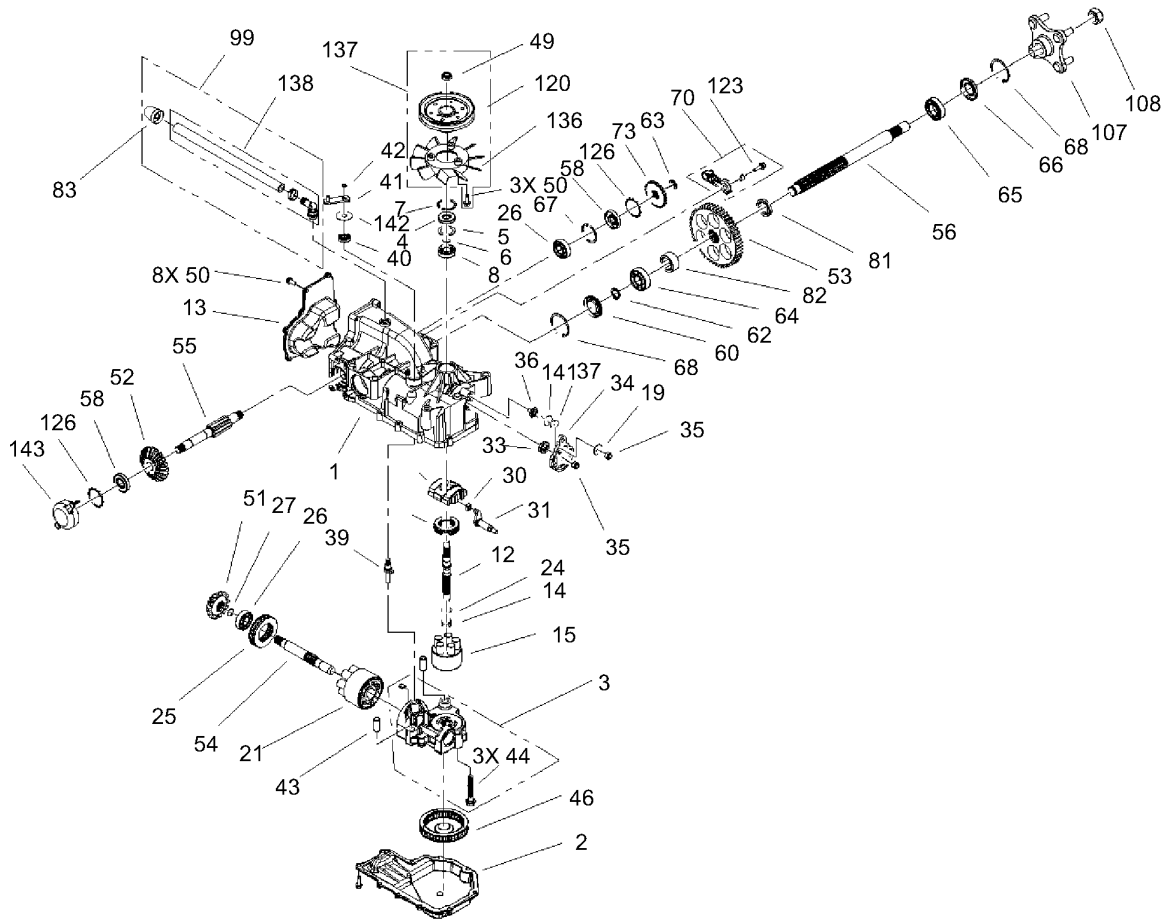

## LH Hydro Transaxle Assembly No. 107-1709

Ref	Part No.	Qty.	Description
1	107-1700	1	Main Housing Kit
2	105-1868	1	Housing-Lower
3	105-1869	1	Center Section Kit ASM
4	92-6543	1	Seal-Lip
5	104-2104	1	Spacer
6	94-1902	1	Ring-Wire, Retaining
7	94-1903	1	Ring-Retaining
8	94-1904	1	Bearing-Shaft, Ball
10	94-1907	1	Swashplate-Variable
11	94-6922	1	Bearing-Thrust
12	104-5067	1	Shaft-Input
13	105-1870	1	Cover-Back
14	94-1936	1	Spring-Block
15	104-2106	1	Cylinder Block ASM
19	5-4460	1	Washer-Pivot
21	94-1913	1	Cylinder Block ASM
24	94-1937	1	Washer-Block, Thrust
25	94-6923	1	Bearing-Thrust
26	104-5311	2	Bearing-Ball
27	104-5307	1	Ring-Retaining
30	94-1910	1	Guide-Slot
31	104-2112	1	Trunnion ASM
33	92-6544	1	Seal-Lip
34	105-1871	1	Arm-Control

Ref	Part No.	Qty.	Description
35	105-1872	2	Nut
36	104-2116	1	Stud
37	105-1873	1	Puck-Friction
38	94-6925	1	Plate-Bypass
39	94-1914	1	Actuator-Bypass
40	92-6545	1	Seal-Lip
41	104-2117	1	Arm-Bypass
42	936109	1	Ring-Retaining
43	94-1927	2	Pin
44	94-6926	3	Bolt
46	105-1874	1	Filter
49	105-1875	1	Nut-Lock
50	104-2120	21	Screw
51	105-1876	1	Gear-Bevel, 14T
52	105-1877	1	Gear-Bevel, 19T
53	105-1878	1	Gear-Bevel, 53T
54	105-1879	1	Shaft-Motor
55	105-1880	1	Shaft-Brake
56	105-1881	1	Shaft-Axle
58	104-5310	2	Seal-Lip
60	105-1882	1	Plug-Side Seal
62	105-1883	1	Ring-Axle, Retaining
63	105-1884	1	Ring-Retaining
64	105-1885	1	Bearing-Ball

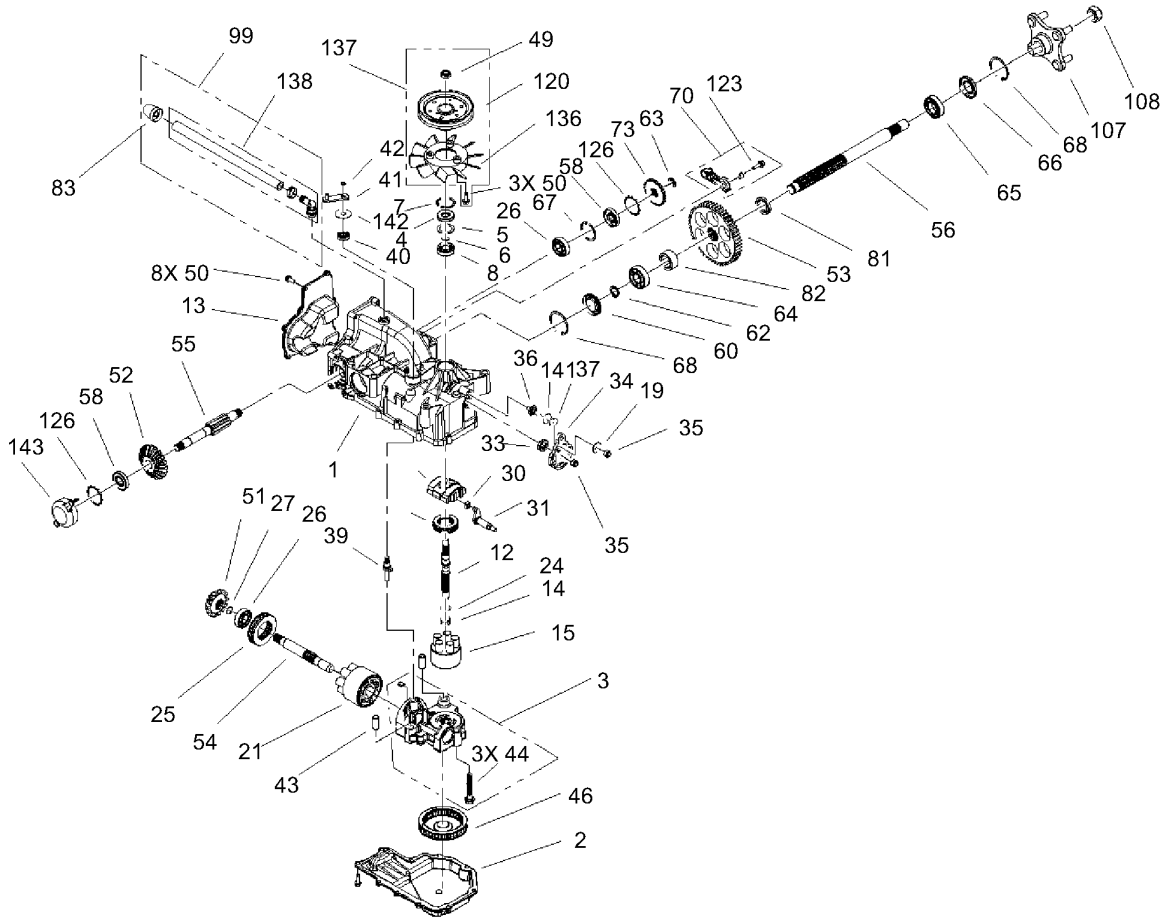

### LH Hydro Transaxle Assembly No. 107-1709 (continued)

Ref	Part No.	Qty.	Description
65	105-1886	1	Bearing-Ball
66	105-1887	1	Seal
67	104-5309	1	Ring-Retaining
68	105-1888	2	Ring-Retaining, Axle
70	105-1889	1	LH Brake Arm ASM
73	105-1890	1	Disc-Brake
81	105-1891	1	Bushing-Axle
82	105-1892	1	Bushing-Axle
83	107-1701	1	Cap Vent ASM
99	107-1702	1	Breather Kit
●100	104-2147	1	Sealant
107	105-1894	1	Hub ASM
108	105-1895	1	Nut
120	104-1754	1	Pulley
123	107-1703	1	Screw-HHF
126	105-1898	2	Ring-Retaining
●134	105-1899	1	Seal Kit
136	105-1927	1	Fan
137	105-1928	1	Fan Pulley Kit
138	107-1704	1	Hose/Fitting ASM
141	107-1705	1	Washer
142	107-1706	1	Washer
143	107-1707	1	Cover-Brake, Plastic

--	--	--	--



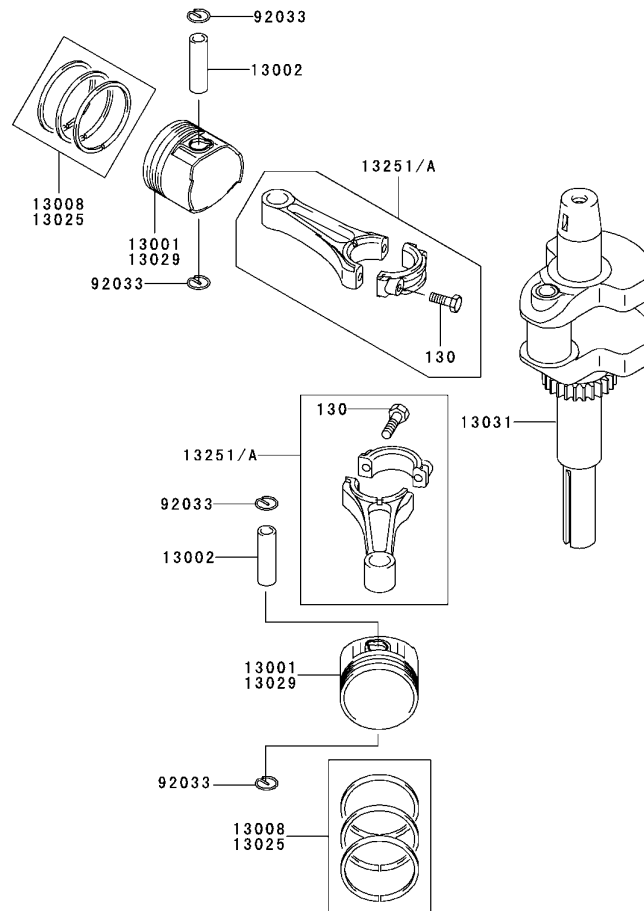

## Piston / Crankshaft Assembly Kawasaki FH531V-CS07

Ref	Part No.	Qty.	Description				
⑤13001	13001-7008	2	Piston-Engine				
⑤13002	13002-7001	2	Pin-Piston				
⑤13008	13008-6055	2	Ring-Set-Piston				
⑤13025	13025-7001	0	Ring-Set-Piston L, 0.5				
⑤13029	13029-7004	0	Piston-Engine L, 0.5				
⑤13031	13031-7001	1	Crankshaft-Comp				
⑤13251	13251-7003	0	Rod-ASM-Connecting				
⑤13251A	13251-7004	2	Rod-ASM-Connecting				
⑤92033	92033-7005	4	Ring-Snap				
⑤130	130G0630	4	Bolt-Flanged (6X30)				

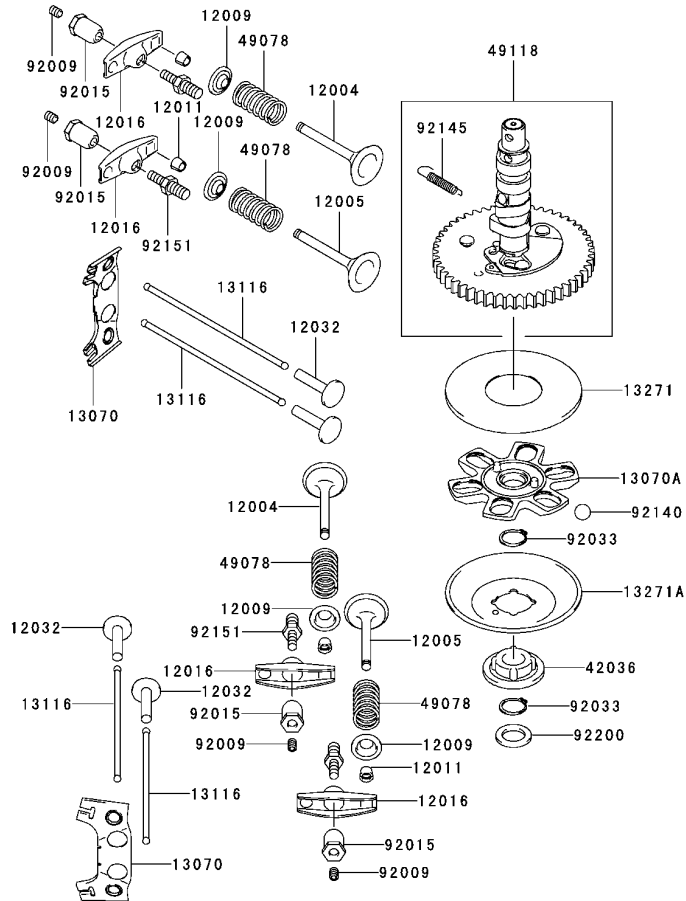

## Valve / Camshaft Assembly Kawasaki FH531V-CS07

Ref	Part No.	Qty.	Description
⑤12004	12004-7003	2	Valve-Intake
⑤12005	12005-7003	2	Valve-Exhaust
⑤12009	12009-7001	4	Retainer-Spring, Valve
⑤12011	12011-2056	8	Collet
⑤12016	12016-7001	4	Arm-Rocker
⑤12032	12032-7001	4	Tappet
⑤13070	13070-7001	2	Guide
⑤13070A	13070-7004	1	Guide
⑤13116	13116-2057	4	Rod-Push
⑤13271	13271-7007	1	Plate
⑤13271A	13271-7021	1	Plate-Governor
⑤42036	42036-7001	1	Sleeve
⑤49078	49078-7001	4	Spring-Valve, Engine
⑤49118	49118-7004	1	Camshaft
⑤92009	92009-2341	4	Screw
⑤92015	92015-2253	4	Nut
⑤92033	92033-7001	2	Ring-Snap
⑤92140	92140-7002	6	Ball
⑤92145	92145-7001	1	Spring
⑤92151	92151-7019	4	Bolt
⑤92200	92200-7001	1	Washer

--	--	--	--



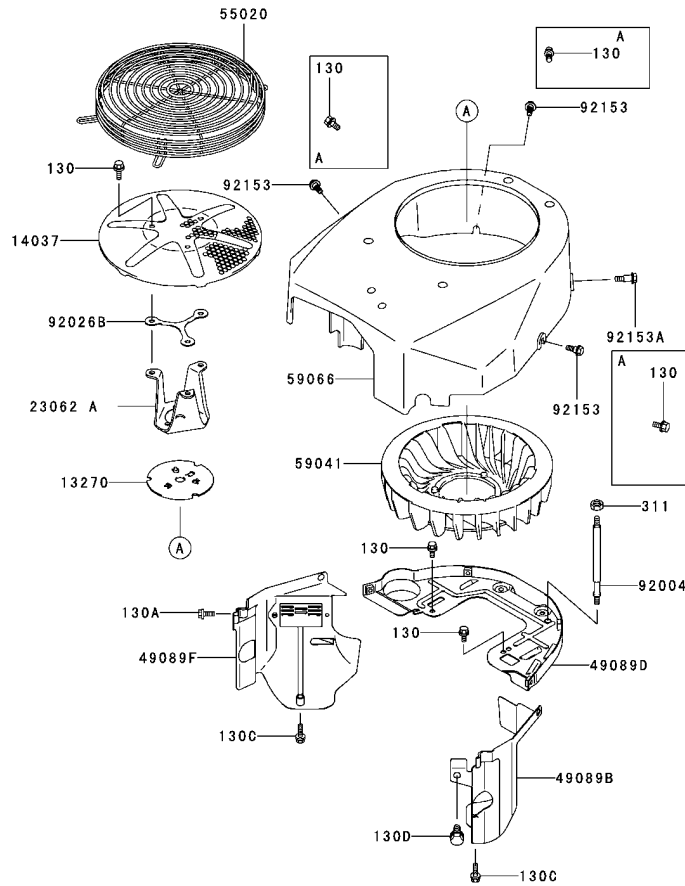

## Cooling Equipment Assembly Kawasaki FH531V-CS07

Ref	Part No.	Qty.	Description
③130	130B0612	5	Bolt-Flanged (6X12)
③130A	130B0616	2	Bolt-Flanged (6X16)
③130C	130B0625	2	Bolt-Flanged (6X25)
③130D	130B0816	1	Bolt-Flanged (8X16)
③13270	13270-7007	1	Plate
③14037	14037-7010-9H	1	Screen
③23062A	23062-7010	1	Bracket
③311	311B0600	2	Nut-Hex (6Mm)
③49089B	49089-7002	1	Shroud-Engine
③49089D	49089-7032	1	Shroud-Engine
③49089F	49089-7034	1	Shroud-Engine
③55020	55020-7004	1	Guard
③59041	59041-7001	1	Fan
③59066	59066-7002	1	Housing-Fan
③92004	92004-7006	2	Stud
③92026B	92026-7007	0	Spacer
③92153	92153-7007	3	Bolt
③92153A	92153-7008	1	Bolt
③92210	92210-0003	4	Nut

--	--	--	--



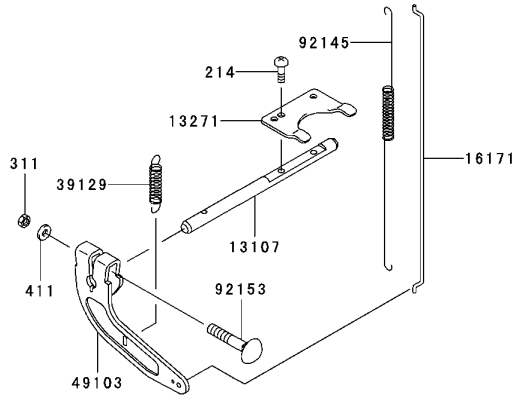
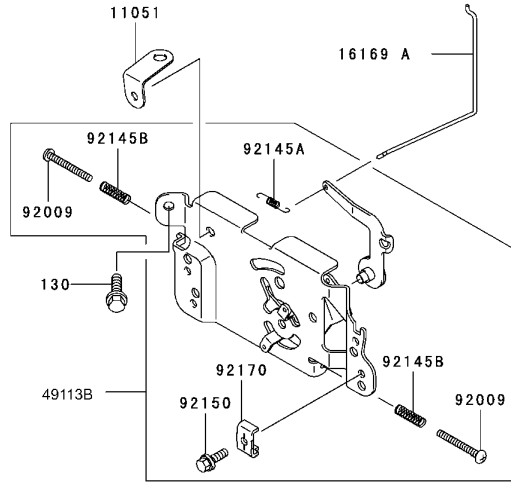

## Control Equipment Assembly Kawasaki FH531V-CS07

Ref	Part No.	Qty.	Description
③11051	11051-7008	1	Bracket
③13107	13107-7010	1	Shaft
③13271	13271-7018	1	Plate
③16169A	16169-7010	1	Link-Choke
③16171	16171-7001	1	Link
③39129	32129-7003	1	Spring-Governor
③49103	49103-7004	1	Arm-Governor
③49113B	49113-7027	1	Panel-Control
③92009	92009-7007	2	Screw (4X35)
③92145	92145-7003	1	Spring
③92145A	92145-7004	1	Spring
③92145B	92145-7005	2	Spring
③92150	92150-2182	1	Bolt (5X18)
③92153	92153-7005	1	Bolt (6X35)
③92170	92170-7001	1	Clamp
③130	130B0612	2	Bolt-Flanged (6X12)
③214	214B0408	2	Screw-Pan (4X8)
③311	311B0600	1	Nut-Hex (6Mm)
③411	411B0600	1	Washer-Plain (6Mm)

--	--	--	--

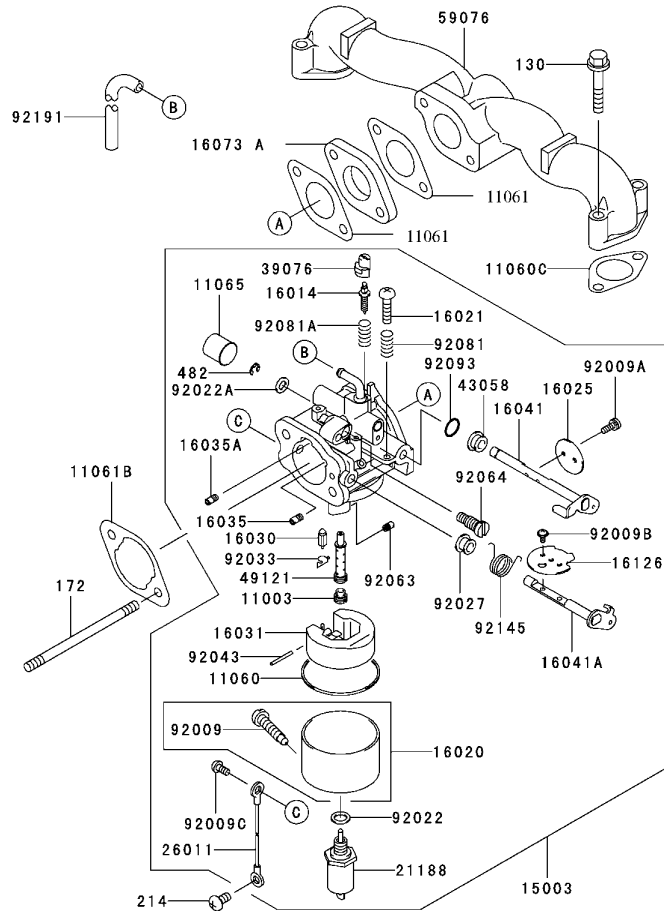

## Carburetor Assembly Kawasaki FH531V-CS07

Ref	Part No.	Qty.	Description
③11003	11003-2105	1	Seat-Valve
③11060	11060-2406	1	Gasket, Chamber
③11060C	11060-7005	2	Gasket, Manifold
③11061	11061-7004	2	Gasket-Insulator
③11061B	11061-7018	1	Gasket-Cleaner, Air
③11065	11065-2061	1	Cap
③15003	15003-7034	1	Carburetor ASM
③16014	16014-2080	1	Screw-Pilot Air
③16020	16020-2141	1	Chamber-Float
③16021	16021-2060	1	Screw-Throttlestop
③16025	16025-2195	1	Valve-Throttle, #130
③16030	16030-2067	1	Valve-Float
③16031	16031-2066	1	Float
③16035	16035-2051	1	Jet-Air #1.4
③16035A	16035-2077	1	Jet-Air, #0.8
③16041	16041-2253	1	Shaft-Carburetor, Throttle
③16041A	16041-7006	1	Shaft-Carburetor
③16073A	16073-7007	1	Insulator
③16126	16126-7008	1	Valve
③21188	21188-2011	1	Solenoid
③26011	26011-2281	1	Wire-Lead
③39076	39076-2053	1	Limiter
③43058	43058-3716	1	Ring
③49121	49121-2227	1	Nozzle-Main #117A

Ref	Part No.	Qty.	Description
③59076	59076-7001	1	Manifold-Intake
③92009	92009-2015	1	Screw
③92009A	92009-2024	2	Screw
③92009B	92009-2081	2	Screw
③92009C	92009-2400	1	Screw
③92022	92022-2231	1	Washer
③92022A	92022-2239	1	Washer
③92027	92027-2025	1	Collar
③92033	92033-2067	1	Ring-Snap
③92043	92043-2226	1	Pin
③92063	92063-2267	1	Jet-Main #116.3
③92064	92064-2103	1	Jet-Pilot #43.8
③92081	92081-2009	1	Spring
③92081A	92081-2256	1	Spring
③92093	92093-2002	1	Seal
③92145	92145-2061	1	Spring
③92191	92191-7016	1	Tube
③130	130B0635	4	Bolt-Flanged (6X35)
③172	172G0685	2	Bolt-Stud
③214	214B0510	1	Screw-Pan (5X10)
③482	482L4000	1	Circlip-Type-E

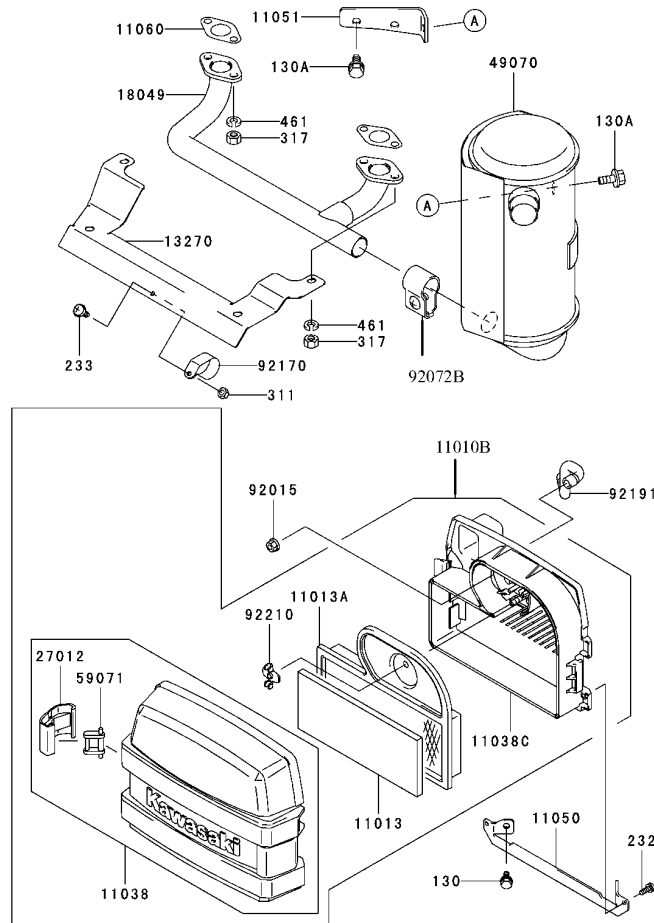

## Air Filter / Muffler Assembly Kawasaki FH531V-CS07

Ref	Part No.	Qty.	Description
③11010B	11011-7007	1	Filter-Assy-Air
③11013	11013-7001	1	Element-Filter, Air
③11013A	11013-7002	1	Element-Filter, Air
③11038	11038-7001	1	Case-ASM-Air Filter
③11038C	11038-7006	1	Air Filter Case ASM
③11050	11050-7006	1	Bracket
③11051	11051-7005-9H	1	Bracket
③11060	11060-7021	2	Gasket-Muffler
③13270	13270-7008	1	Plate
③18049	18049-7001	1	Pipe-Exhaust
③27012	27012-7001	2	Hook-Filter, Air
③49070	49070-7002	1	Muffler-Comp
③59071	59071-7001	2	Joint
③92015	92015-1193	2	Nut
③92072B	92072-7008	1	Band
③92170	92170	1	Clamp
③92191	92191-7001	1	Tube
③92210	92210-7004	1	Nut
③130	130B0612	2	Bolt-Flanged (6X12)
③130A	130B0816	2	Bolt-Flanged (8X16)
③232	232B0514	2	Screw-Pan
③233	233B0416	1	Screw (4X16)
③311	311B0400	1	Nut-Hex (4Mm)

Ref	Part No.	Qty.	Description
③317	317R0800	4	Nut-Hex, Small (8Mm)
③461	461F0800	4	Washer-Spring (8Mm)

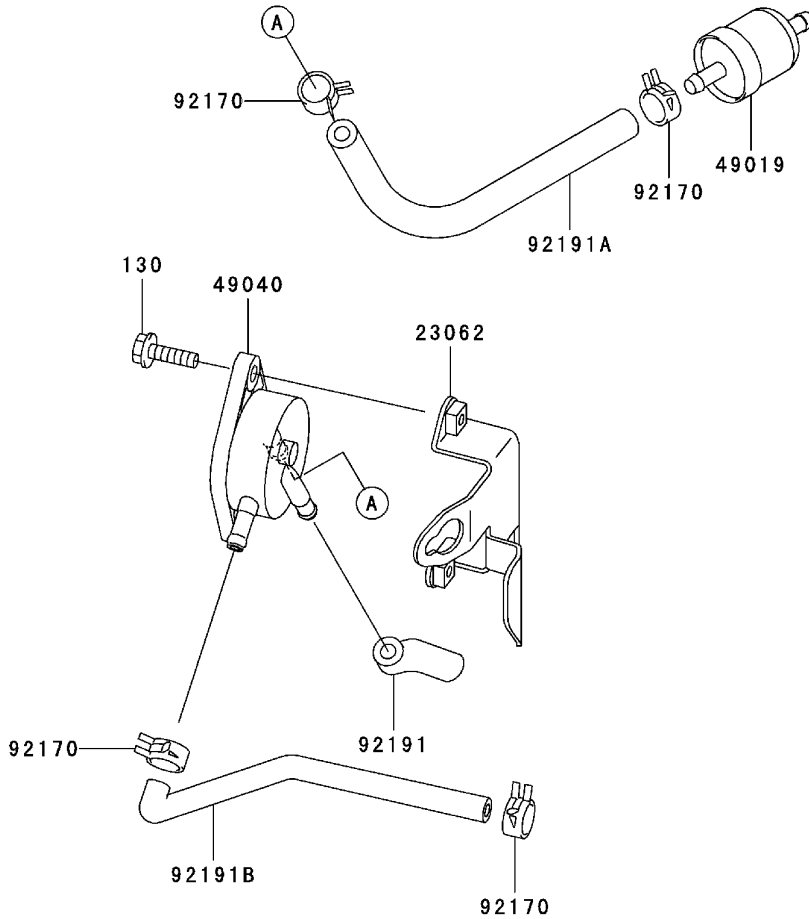

## Fuel Tank / Fuel Valve Assembly Kawasaki FH531V-CS07

Ref	Part No.	Qty.	Description				
③23062	23062-7004-9H	1	Bracket				
③49019	49019-7001	1	Filter-Fuel				
③49040	49040-7001	1	Pump-Fuel				
③92170	92170-2088	4	Clamp				
③92191	92199-7002	1	Tube				
③92191A	92191-7003	1	Tube (6.35X12.7X160)				
③92191B	92191-7004	1	Tube				
③130	130B0620	2	Bolt-Flanged (6X20)				

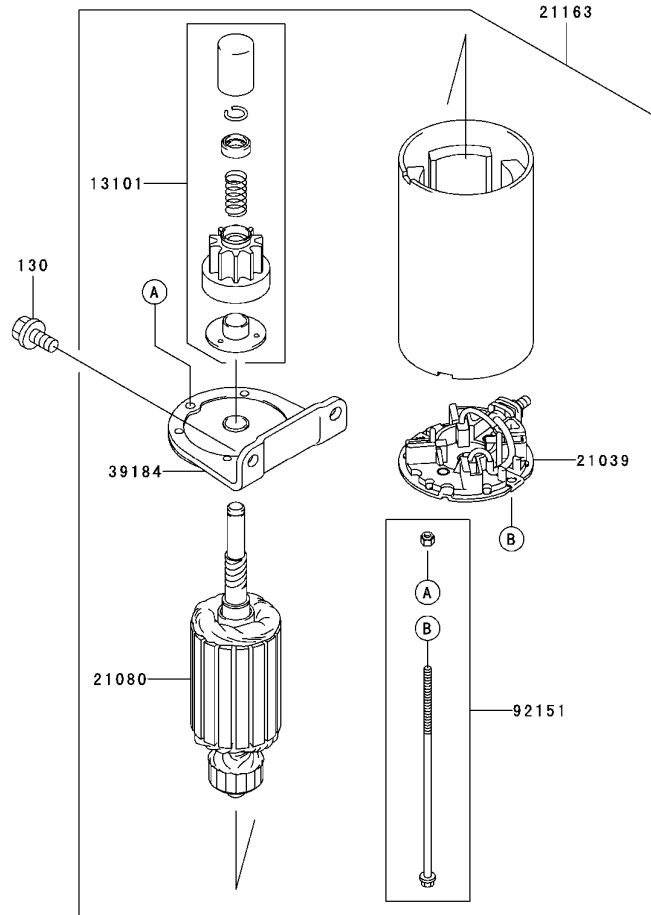

## Starter Assembly Kawasaki FH531V-CS07

Ref	Part No.	Qty.	Description
①13101	13101-7001	1	Gear ASM
②21039	21039-7001	1	Brush
③21080	21080-7001	1	Armature
④21163	21163-7001	1	Starter-Electric
⑤39184	39184-7001	1	Bracket ASM
⑥92151	92151-7013	1	Bolt
⑦130	130B0816	2	Bolt-Flanged (8X16)

--	--	--	--



## NOTES

# NOTES

