



16-42Z TimeCutter™ Z Riding Mower

Model No. 74330 - 240000001 and up.

Parts Catalog

Ordering Replacement Parts

To order replacement parts, please supply the part number, the quantity, and the description of each part desired.

Understanding Reference Numbers

Each identified part in an illustration has a reference number. The reference number for a part also appears in the parts list, along with other information about the part.

This catalog uses two special reference number formats, one to indicate parts in a service assembly and another to indicate the quantity of a given part in an illustration.

Service Assembly Reference Numbers

Parts in service assemblies have reference numbers in the form a:b. The a represents the reference number of the entire service assembly and the b represents a sequential number unique to each part within the service assembly.

For example, a wheel assembly might be identified by reference number 6, the tire by 6:1, the valve by 6:2, and the wheel by 6:3. When you order the assembly identified by reference number 6, you receive all parts identified by reference numbers 6:1, 6:2, and 6:3. However, you may also order any part individually. Reference numbers of this type appear in illustrations and in part lists.

Reference Numbers Indicating Quantity

In an illustration, if a reference number indicates more than one part, the reference number has the form nX y. The n represents the quantity of the part, the X is the multiplication symbol, and the y represents the reference number.

For example, in an illustration, the reference number 2X 37 means that two of the parts identified by reference number 37 are indicated.

Contents

Description	Page	Description	Page
Frame Assembly	3	Crankcase Assembly Briggs and Stratton 286H77-0165-E1	19
Control Assembly	5	Oil Filter, Tube and Pump Assembly Briggs and Stratton 286H77-0165-E1	20
Hydro and Belt Drive Assembly	6	Carburetor Assembly Briggs and Stratton 286H77-0165-E1	21
RH Hydrostat Assembly No. 107-2466	7	Governor Assembly Briggs and Stratton 286H77-0165-E1	22
LH Hydrostat Assembly No. 107-2465	9	Blower Housing Assembly Briggs and Stratton 286H77-0165-E1	23
Engine Assembly	11	Starter Assembly Briggs and Stratton 286H77- 0165-E1	24
Deck, Spindle and Belt Drive Assembly	13	Gasket Assembly Briggs and Stratton 286H77- 0165-E1	25
Deflector and Baffle Assembly	14	Carburetor Overhaul Kit Assembly Briggs and Stratton 286H77-0165-E1	26
Electrical System Assembly	15		
Cylinder Assembly Briggs and Stratton 286H77-0165-E1	16		
Cylinder Head Assembly Briggs and Stratton 286H77-0165-E1	17		
Crankshaft Assembly Briggs and Stratton 286H77-0165-E1	18		

Part Description Abbreviations

Part descriptions in this catalog may include the following abbreviations.

AR. as required	HYD. hydraulic
ASM. assembly	LH. left hand
BBC. blade brake clutch	NI. nylon insert
CARR. carriage	NPTF. national pipe thread fine
DEG. degrees	PFH. phillips flat head
EXT. external	PPH. phillips pan head
FH. flat head	PPHTF. phillips pan head thread forming
GA. gauge	PRH. phillips round head
HD. heavy-duty	PTH. phillips truss head
HF. hex flange	PTO. power-take-off
HH. hex head	RH. right hand
HHF. hex head flange	ROPS. roll-over protection system
HHFTF. hex head flange thread forming	SFH. slotted fillister head
HJ. hex jam	SHH. slotted hex head
HLH. hex lag head	SHWH. slotted hex washer head
HOC. height-of-cut	SPH. slotted pan head
HSBH. hex socket button head	SQH. square head
HSFH. hex socket flat head	SRH. slotted round head
HSH. hex socket head	STD. standard
HWH. hex washer head	TAP. self tapping
HWHTF. hex washer head thread forming	TTH. torx truss head

Footnotes

- | | |
|---|---|
| ❶ Not illustrated | ❷ Not serviced separately |
| ❸ Included in Engine Gasket Set-Ref. 358. | ❹ Included in Valve Gasket Set-Ref. 1095. |
| ❺ Included in Carburetor Overhaul Kit-Ref. 121. | ❻ Included in Carburetor Gasket Set-Ref. 977. |
| ❼ Obtain from your local Briggs & Stratton dealer | |

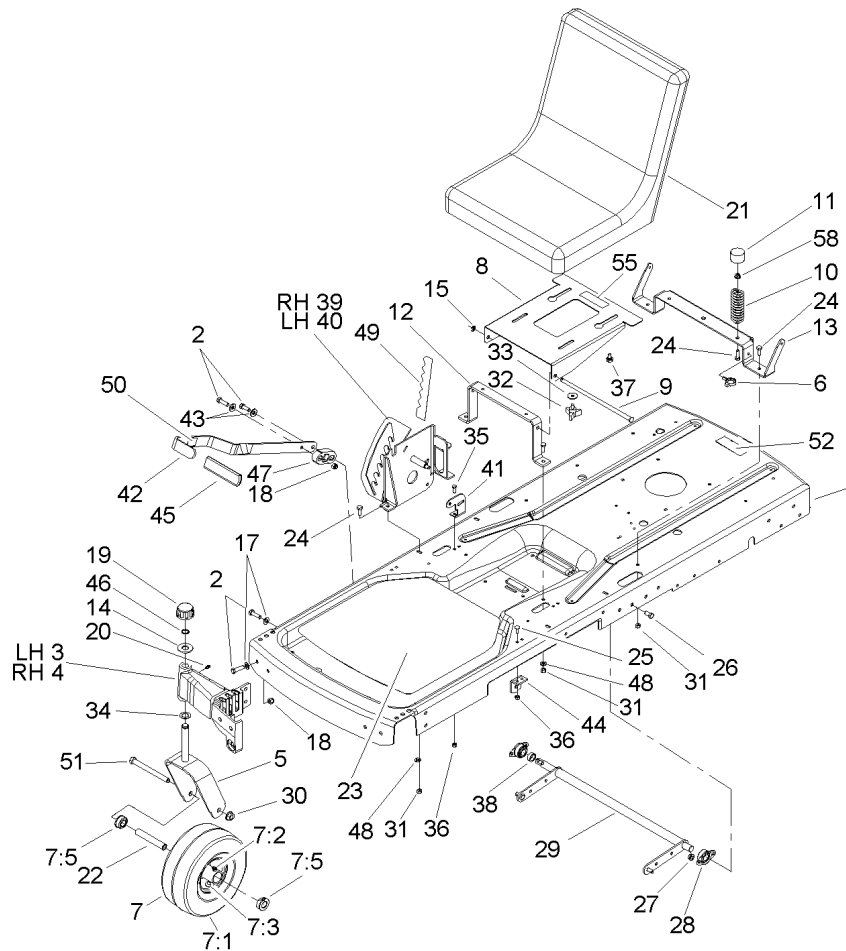

Frame Assembly

Ref	Part No.	Qty.	Description
1	107-1744-01	1	Frame
2	323-18	10	Screw-HH
3	105-6986-01	1	Caster-LH
4	105-6985-01	1	Castor-RH
5	106-2196-01	2	Caster Fork ASM
6	105-1853	1	Clamp-Hose
7	105-3471	2	Front Wheel And Tire ASM
7:1	105-1943	1	Tire
7:2	302-11	1	Fitting-Lube, 45 DEG
7:3	232-27	1	Stem-Valve
7:5	114-1640	2	Bushing-Flange
7:99	93-4244	1	Tube-Inner (W/Valve)
8	105-6953-03	1	Bracket-Seat
9	105-6955	1	Pin-Pivot
10	92-7054	2	Spring-Compression
11	701178	2	Cap-Protector
12	105-6954-03	1	Brace-Seat, Front
13	106-2210-03	1	Brace-Seat, Rear
14	28-2480	2	Washer
15	105-7004	1	E-Ring
17	3256-24	8	Washer-Flat
18	3296-39	9	Nut-Lock, NI
19	61-9780	2	Cap-Hub
20	302-5	2	Fitting-Grease

Ref	Part No.	Qty.	Description
21	105-6962	1	Seat
22	104-3667	2	Spanner-Wheel
23	105-3460	1	Pad-Antiskid
24	322-4	14	Screw-HH
25	3229-1	4	Screw-CARR
26	323-4	4	Screw-HH
27	3290-357	4	Nut-HHF, Whiz
28	1-633102	2	Bearing-Flange, Side
29	105-3499-03	1	Lift Arm ASM
30	32128-23	2	Nut-HF
31	3296-29	12	Nut-Lock, NI
32	92-9674	2	Knob
33	5-4460	2	Washer-Pivot
34	3-6498	2	Washer-Thrust
35	321-4	4	Screw-HH
36	3296-42	8	Nut-Lock, NI
37	37-8770	2	Bolt-Shoulder
38	106-2222	1	Spacer
39	106-2158-03	1	RH Plate ASM
40	106-2159-03	1	LH Plate ASM
41	106-2180	2	Bracket-Bellcrank
42	105-3435-03	1	Lever-Lift
43	98-5975	2	Washer-Belleville
44	105-3439	2	Bracket-Lift

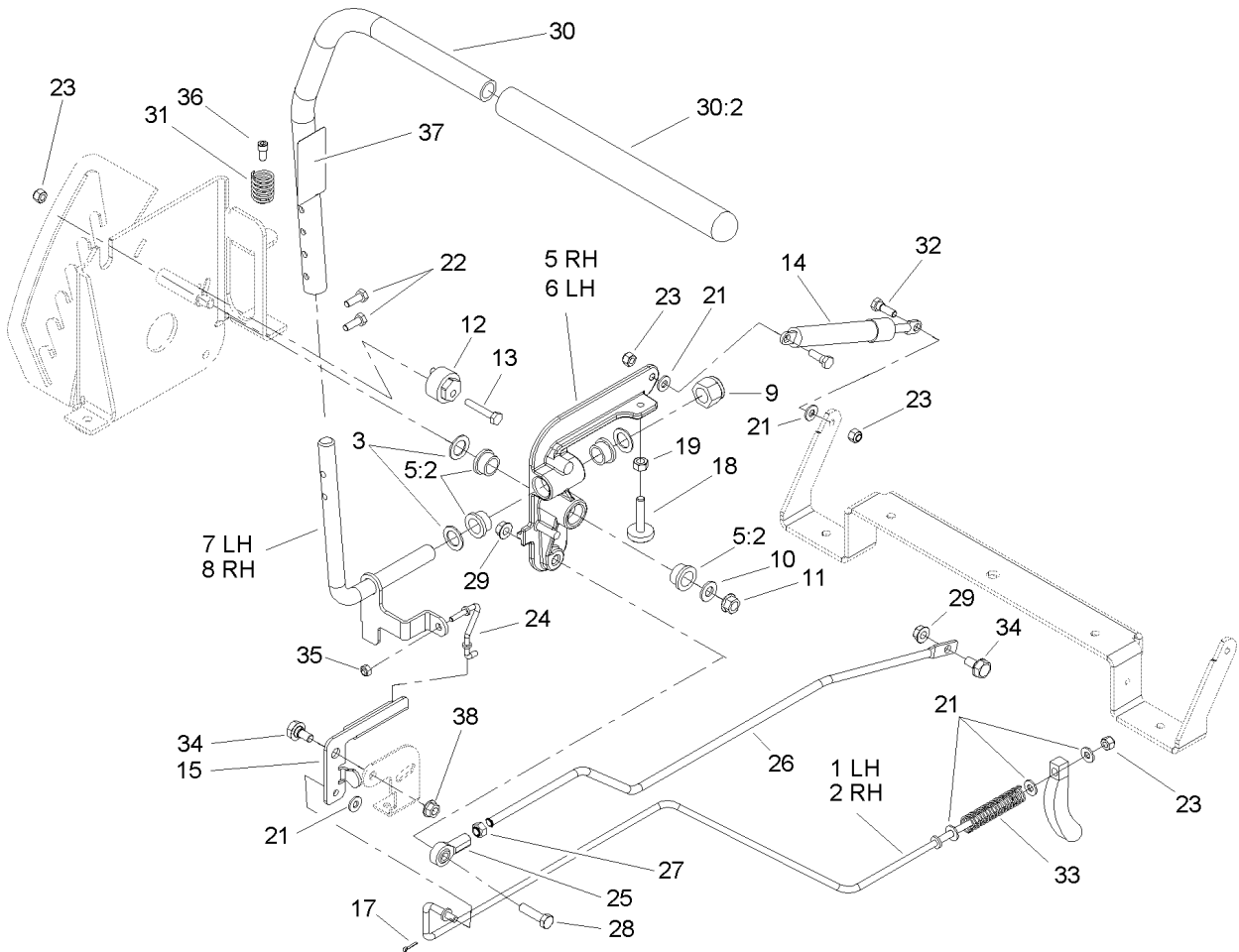

Control Assembly

Ref	Part No.	Qty.	Description
1	105-7045	1	Rod-Brake, LH
❶2	105-7044	1	Rod-Brake, RH
3	105-3481	6	Washer-Thrust
5	106-8671	1	RH Actuator Arm W/Bushing ASM
5:2	105-3455	4	Bushing
❶6	106-8672	1	LH Actuator Arm W/Bushing ASM
❶6:2	105-3455	4	Bushing
7	105-3488	1	LH Pivot Shaft ASM
❶8	105-3487	1	RH Pivot Shaft ASM
9	3296-53	2	Nut-Lock, NI
10	3256-24	2	Washer-Flat
11	3296-59	2	Nut-Lock, NI
12	105-3485	2	Bushing-Eccentric
13	321-9	2	Screw-HH
14	103-2913	2	Damper-Control, Motion
15	106-2181	2	Bellcrank
17	3272-5	2	Pin-Cotter
18	105-3486	2	Stop-Adjustment
19	3217-6	2	Nut-Hex
21	3256-22	12	Washer-Flat
22	321-4	4	Screw-HH
23	3296-42	8	Nut-Lock, NI
24	106-2179	2	Link-Brake
25	1-543017	2	Balljoint-RH

Ref	Part No.	Qty.	Description
26	105-7048	2	Rod-Hydro
27	3219-2	2	Nut-Hex
28	322-6	2	Screw-HH
29	32128-20	4	Nut-HF
30	106-2242	2	Handle ASM
30:2	1-633257	1	Grip-Control, Motion
31	105-3469	2	Spring-Compression
32	106-2214	4	Bolt-Shoulder
33	105-3465	2	Spring-Compression
34	37-8771	4	Bolt-Shoulder
35	3296-2	2	Nut-Lock
36	3274-52	2	Screw-HSH
37	106-8742	2	Decal
38	32128-25	2	Nut-HF

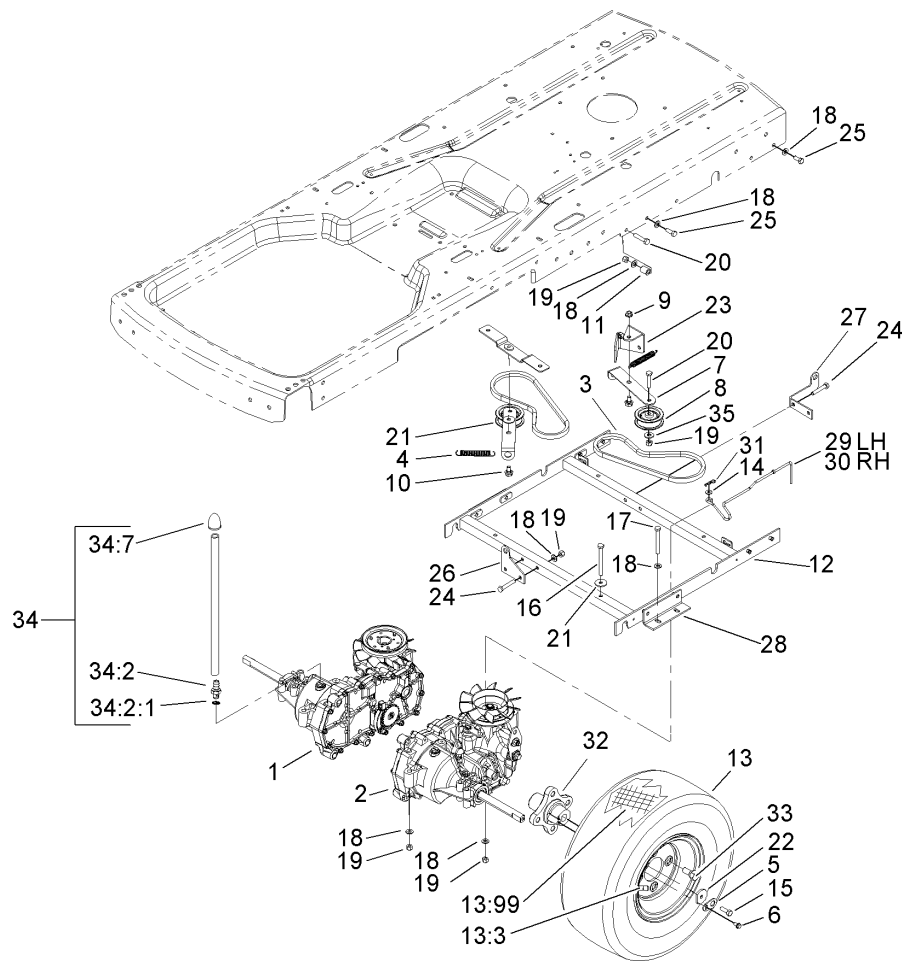

Hydro and Belt Drive Assembly

Ref	Part No.	Qty.	Description
1	107-2466	1	RH Hydrostat ASM
2	107-2465	1	LH Hydrostat ASM
3	106-2174	2	V-Belt
4	95-3805	2	Spring
5	105-3438	2	Tab-Locking
6	3234-13	2	Screw-HHF
7	105-7047	2	Arm-Idler
8	106-2176	2	Pulley-Idler
9	32128-25	1	Nut-HF
10	37-8770	2	Bolt-Shoulder
11	105-1941	2	Spacer
12	107-2462-03	1	Hydro Mount ASM
13	106-7004	2	Wheel And Tire ASM
13:3	232-27	1	Stem-Valve
13:99	107-2491	1	Tube-Tire
14	3256-1	2	Washer-Flat
15	3210-5	2	Screw-HH
16	322-20	4	Screw-HH
17	322-13	4	Screw-HH
18	3256-23	24	Washer-Flat
19	3296-29	16	Nut-Lock, NI
20	322-7	4	Screw-HH
21	5-4460	5	Washer-Pivot
22	106-7001	2	Washer-Wheel

Ref	Part No.	Qty.	Description
23	107-1734	1	Stop-Clutch
24	322-9	4	Screw-HH
25	322-4	8	Screw-HH
26	105-7049	1	Bracket-Spring
27	105-7046	1	Bracket-Spring
28	105-7039-03	2	Support-Hydro
29	107-2463	1	Arm-Bypass, LH
30	107-2464	1	Arm-Bypass, RH
31	1-806003	2	Pin-Hair
32	106-6987-03	2	Hub-Machined
33	71-4450	8	Bolt-Lug
34	106-7002	2	Vent Hose ASM
34:2	93-3818	1	Fitting ASM
34:2:1	93-3816	1	O-Ring
34:7	107-1701	1	Cap Vent ASM
35	3256-3	2	Washer-Flat

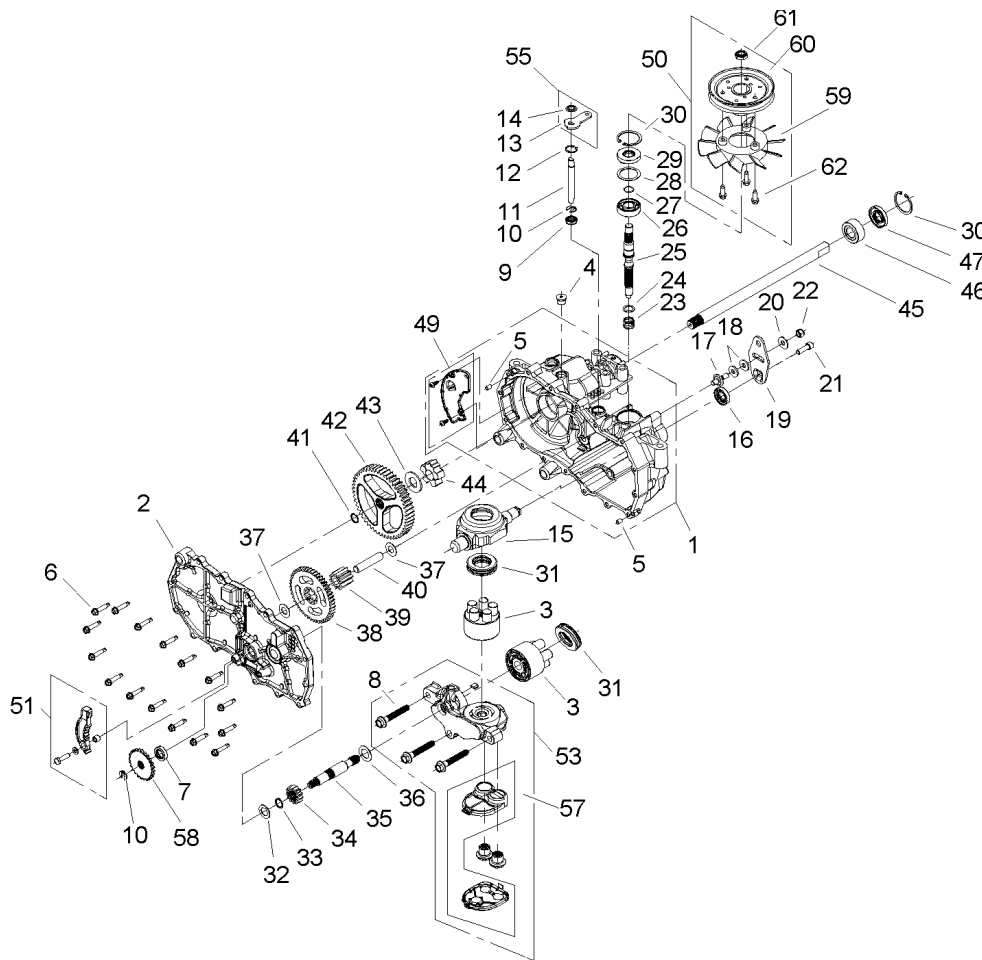

RH Hydrostat Assembly No. 107-2466

Ref	Part No.	Qty.	Description
1	106-8674	1	LH Main Housing ASM
2	106-8675	1	LH Side ASM
3	104-2106	1	Cylinder Block ASM
4	104-2189	1	Plug-Thread, Straight
5	9004800-2506	2	Pin-Hydrogear
6	104-5305	16	Screw-HHF
7	104-5347	1	Seal-Oil
8	94-6926	3	Bolt
9	106-8676	1	Seal-Lip
10	106-8677	2	Ring-Retaining, EXT
11	106-8678	1	Rod-Bypass
12	106-8679	1	Ring-Retaining, Int
13	107-2490	1	Arm-Bypass
14	106-8681	1	Ring-Retaining, EXT
15	104-5304	1	Swashplate-Trunnion
16	104-5313	1	Seal-Lip
17	104-2116	1	Stud
18	105-1873	2	Puck-Friction
19	106-8747	1	Arm-Control
20	5-4460	1	Washer-Pivot
21	107-2488	1	Screw
22	105-1872	1	Nut
23	94-1936	1	Spring-Block

Ref	Part No.	Qty.	Description
24	94-1937	1	Washer-Block, Thrust
25	104-5306	1	Shaft-Input
26	104-5311	1	Bearing-Ball
27	104-5307	1	Ring-Retaining
28	104-5308	1	Spacer
29	104-5310	1	Seal-Lip
30	104-5309	2	Ring-Retaining
31	94-6922	2	Bearing-Thrust
32	104-5339	1	Washer-Flat
33	104-5340	1	Ring-Retaining
34	104-5316	1	Gear-Pinnion, 13T
35	106-8683	1	Shaft-Motor
36	104-5360	1	Washer-Shaft, Motor
37	94-1933	2	Washer
38	104-5317	1	Gear
39	104-5318	1	Gear-Jackshaft, 10T
40	104-5329	1	Pin-Jackshaft
41	104-5328	1	Ring-Retaining, Spiral
42	106-8684	1	Gear-Bull, 52T
43	94-1943	1	Washer
44	104-5320	1	Bearing-Sleeve
45	106-8685	1	Axle
46	104-5321	1	Bearing-Sleeve, Outboard
47	104-5322	1	Seal-Lip

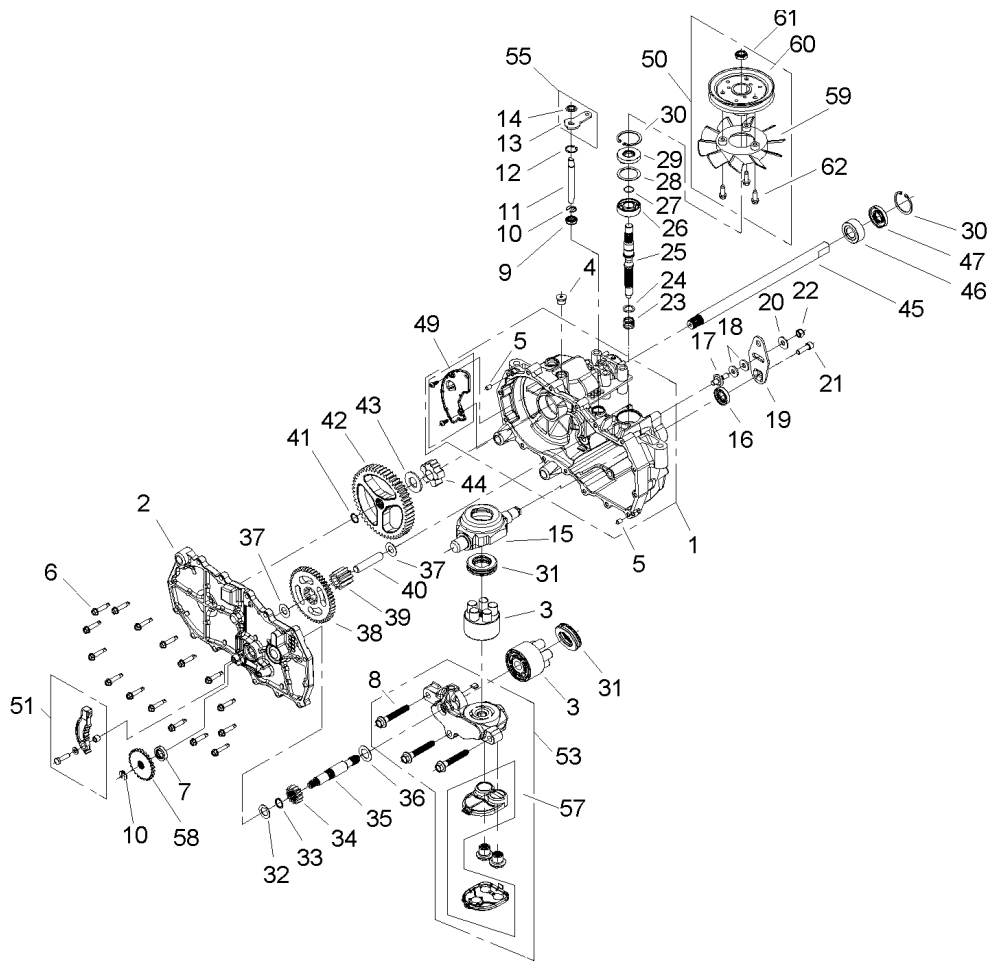

RH Hydrostat Assembly No. 107-2466 (continued)

Ref	Part No.	Qty.	Description
①48	106-8686	1	Seal Kit
49	106-8687	1	LH Expansion Plate Kit
50	105-1928	1	Fan Pulley Kit
51	106-8688	1	Brake Arm Kit
53	106-8690	1	LH Center Section Filter Kit
①54	104-2147	1	Sealant
55	107-2489	1	Bypass Arm Kit
57	106-8693	1	Filter Kit
58	106-8694	1	Disc-Brake, Cog
59	105-1927	1	Fan
60	105-1896	1	Pulley
61	105-1875	1	Nut-Lock
62	104-2120	3	Screw

--	--	--	--

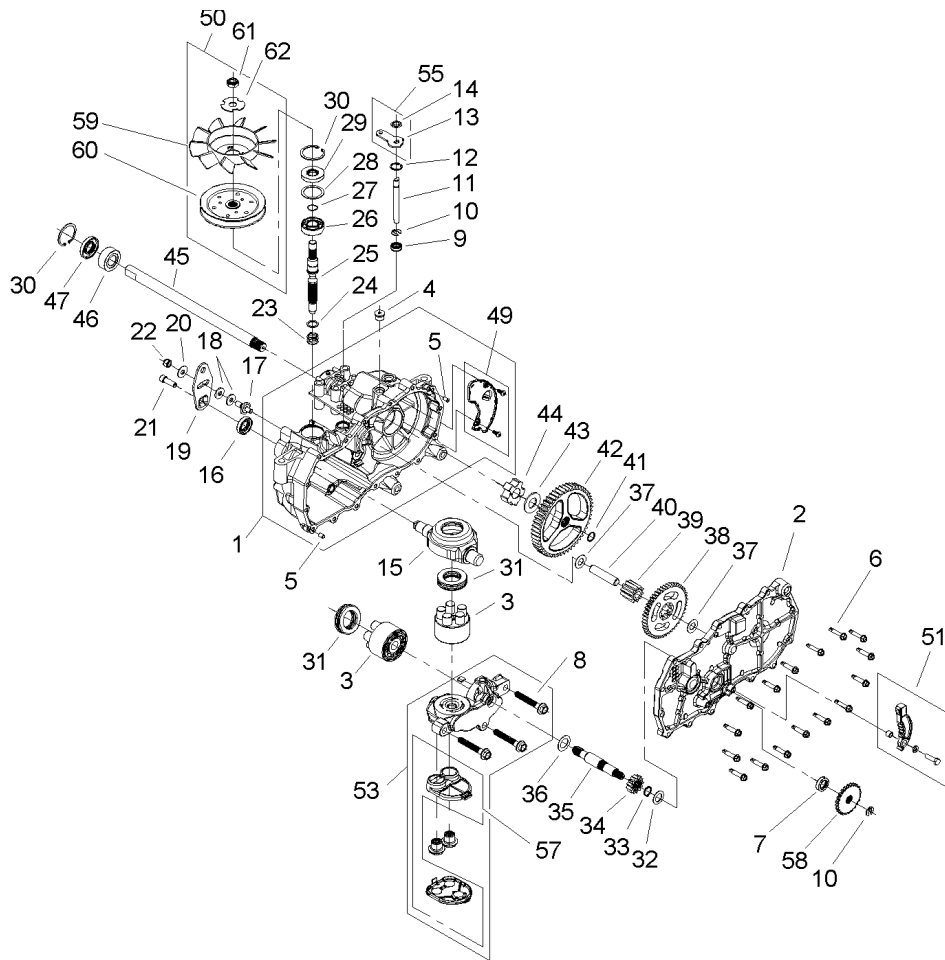

LH Hydrostat Assembly No. 107-2465

Ref	Part No.	Qty.	Description
1	106-8695	1	RH Main Housing ASM
2	106-8696	1	RH Side ASM
3	104-2106	1	Cylinder Block ASM
4	104-2189	1	Plug-Thread, Straight
5	9004800-2506	2	Pin-Hydrogear
6	104-5305	16	Screw-HHF
7	104-5347	1	Seal-Oil
8	94-6926	3	Bolt
9	106-8676	1	Seal-Lip
10	106-8677	2	Ring-Retaining, EXT
11	106-8678	1	Rod-Bypass
12	106-8679	1	Ring-Retaining, Int
13	107-2490	1	Arm-Bypass
14	106-8681	1	Ring-Retaining, EXT
15	104-5304	1	Swashplate-Trunnion
16	104-5313	1	Seal-Lip
17	104-2116	1	Stud
18	105-1873	2	Puck-Friction
19	106-8747	1	Arm-Control
20	5-4460	1	Washer-Pivot
21	107-2488	1	Screw
22	105-1872	1	Nut
23	94-1936	1	Spring-Block

Ref	Part No.	Qty.	Description
24	94-1937	1	Washer-Block, Thrust
25	104-5306	1	Shaft-Input
26	104-5311	1	Bearing-Ball
27	104-5307	1	Ring-Retaining
28	104-5308	1	Spacer
29	104-5310	1	Seal-Lip
30	104-5309	2	Ring-Retaining
31	94-6922	2	Bearing-Thrust
32	104-5339	1	Washer-Flat
33	104-5340	1	Ring-Retaining
34	104-5316	1	Gear-Pinnion, 13T
35	106-8683	1	Shaft-Motor
36	104-5360	1	Washer-Shaft, Motor
37	94-1933	2	Washer
38	104-5317	1	Gear
39	104-5318	1	Gear-Jackshaft, 10T
40	104-5329	1	Pin-Jackshaft
41	104-5328	1	Ring-Retaining, Spiral
42	106-8684	1	Gear-Bull, 52T
43	94-1943	1	Washer
44	104-5320	1	Bearing-Sleeve
45	106-8685	1	Axle
46	104-5321	1	Bearing-Sleeve, Outboard
47	104-5322	1	Seal-Lip

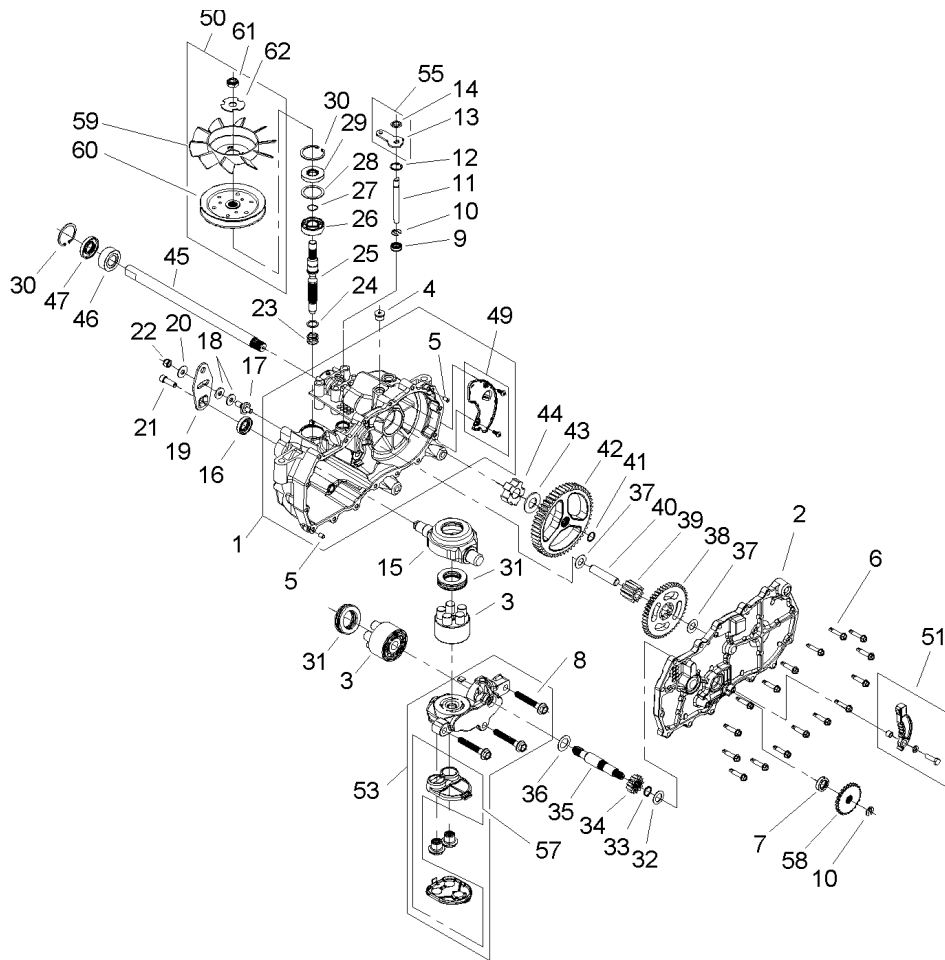

LH Hydrostat Assembly No. 107-2465 (continued)

Ref	Part No.	Qty.	Description
●48	106-8686	1	Seal Kit
49	106-8697	1	RH Expansion Plate Kit
50	106-8698	1	Fan Pulley Kit
51	106-8688	1	Brake Arm Kit
53	106-8699	1	RH Center Section Filter Kit
●54	104-2147	1	Sealant
55	107-2489	1	Bypass Arm Kit
57	106-8693	1	Filter Kit
58	106-8694	1	Disc-Brake, Cog
59	110-8566	1	Fan-6 Inch, 10 Blade
60	104-1754	1	Pulley
61	105-1875	1	Nut-Lock
62	107-9122	3	Washer-Slotted

--	--	--	--

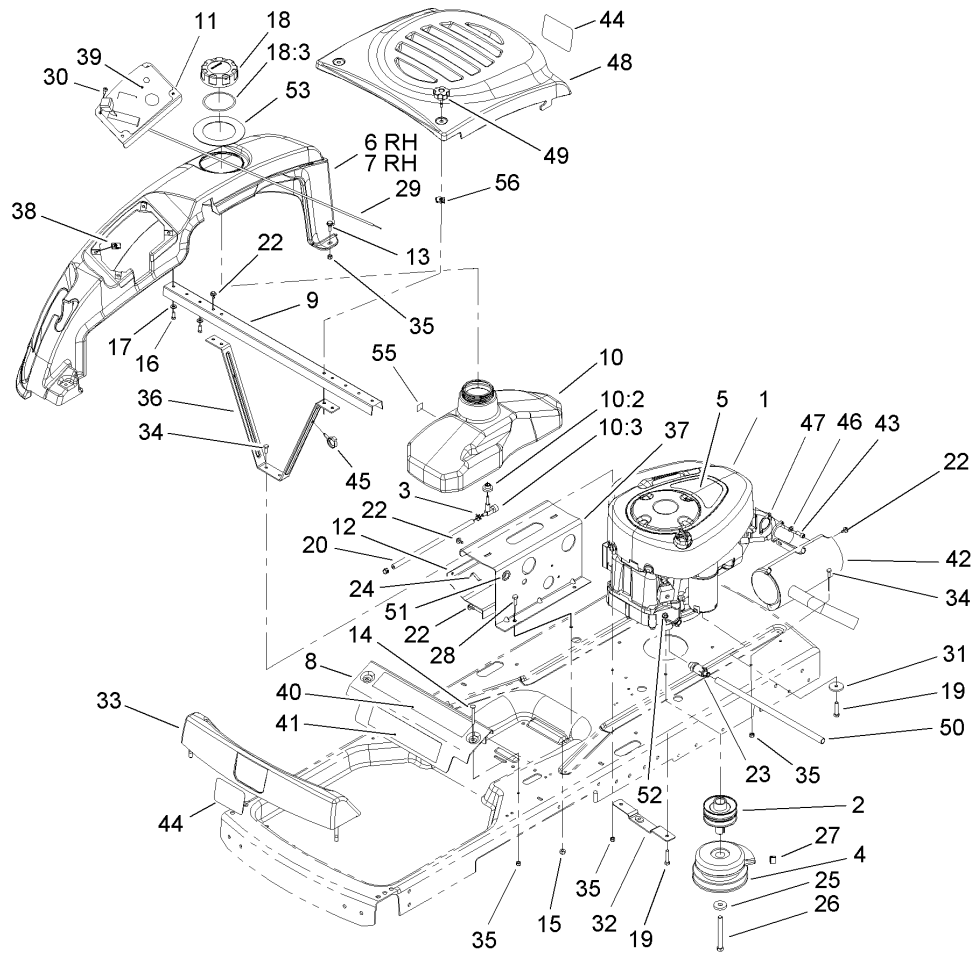

Engine Assembly

Ref	Part No.	Qty.	Description	Ref	Part No.	Qty.	Description
1		1	Engine-Briggs And Stratton, 286H77-0165-E1	22	46-8560	7	Screw-HHF
2	105-3472	1	Pulley-Engine	23	92-6877	1	Valve-Drain, Oil
3	2412-98	2	Clamp	24	609830	2	Spring
4	104-3334	1	Clutch-Electric	25	112843	1	Washer
5	106-6409	1	Decal-Engine	26	3212-16	1	Screw-HH
6	106-2161	1	Cover-Side, RH	27	98-5023	1	Bumper
7	106-2162	1	Cover-Side, LH	28	322-4	2	Screw-HH
8	106-2164-03	1	Bracket-Support, Front	29	104-3626	1	Cable-Throttle
9	106-2165-03	1	Bracket-Support, Rear	30	3258-166	4	Screw-PRH
10	105-3464	1	Gas Tank ASM	31	62-7190	2	Spacer-Steel
10:2	46-6560	1	Bushing	32	106-2156	1	Plate-Mount, Idler
10:3	104048	1	Valve-Fuel	33	105-6965	1	Footrest ASM
11	106-2167-03	1	Panel-Control	34	321-4	2	Screw-HH
12	105-3453-03	1	Plate-Support	35	3296-42	6	Nut-Lock, NI
13	11-9030	2	Screw-Shoulder	36	106-6994-03	1	Brace ASM
14	3229-7	2	Screw-CARR	37	107-2485-03	1	Plate-Tank
15	3296-29	2	Nut-Lock, NI	38	107069	4	Clip
16	46-8090	4	Screw-Plastite	39	106-2224	1	Decal-Control
17	3256-22	4	Washer-Flat	40	107-7398	1	Decal-Danger
18	88-3980	1	Gas Cap ASM	41	106-6992	1	Decal
18:3	88-4010	1	Gasket-Cap, Gas	42	106-7007	1	Muffler
19	322-7	4	Screw-HH	43	3274-10	2	Screw-HSH
20	106-8720	1	Hose-Fuel	44	105-6971	2	Decal
				45	105-1853	2	Clamp-Hose

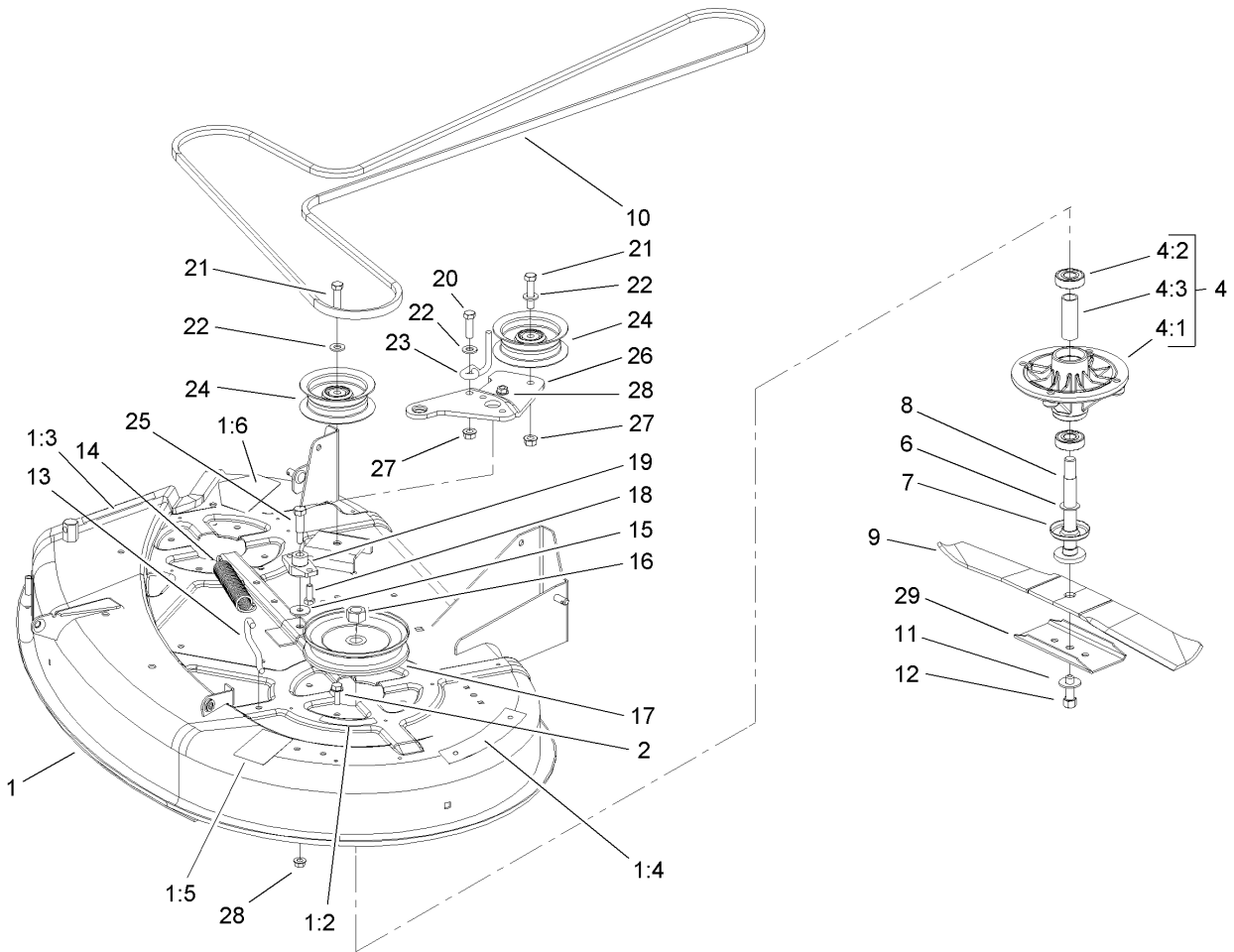

Deck, Spindle and Belt Drive Assembly

Ref	Part No.	Qty.	Description
1	106-8731	1	42In Deck ASM
1:2	68-3660	1	Decal-Danger, Shield
1:3	68-3650	1	Decal-Danger, Deflector
1:4	79-3140	1	Decal-Danger
1:5	105-7015	1	Decal-Routing, Belt
1:6	93-1122	1	Decal-Danger
2	32144-41	8	Screw-Taptite
4		2	Spindle ASM
4:1	88-4510	1	Housing-Spindle
4:2	100-1048	2	Bearing-Ball
4:3	62-3661	1	Spacer-Bearing
6	80-4380	2	Spacer
7	80-4360	2	Shield-Bearing
8	80-4341	2	Shaft
9	106-2247-03	2	Blade
10	106-2173	1	Belt-V
11	3290-465	2	Washer-Belleville
12	26-0671	2	Screw-Blade
13	88-5970	1	Hook-Return, Spring
14	106-2177	1	Spring-Extension
15	5-4460	1	Washer-Pivot
16	3219-6	2	Nut-Hex
17	88-5330	2	Pully-Deck
18	322-4	2	Screw-HH

Ref	Part No.	Qty.	Description
19	88-4980	1	Bushing-Arm, Idler
20	323-7	1	Screw-HH
21	323-9	2	Screw-HH
22	3256-24	3	Washer-Flat
23	107-7307	1	Guide-Idler, Belt
24	106-2175	2	Pulley-Idler, Flat
25	7-0030	1	Bolt-Shoulder
26	107-2467-03	1	Arm-Idler
27	32128-21	2	Nut-HF
28	32128-25	3	Nut-HF
29	106-2248-03	2	Stiffener-Blade

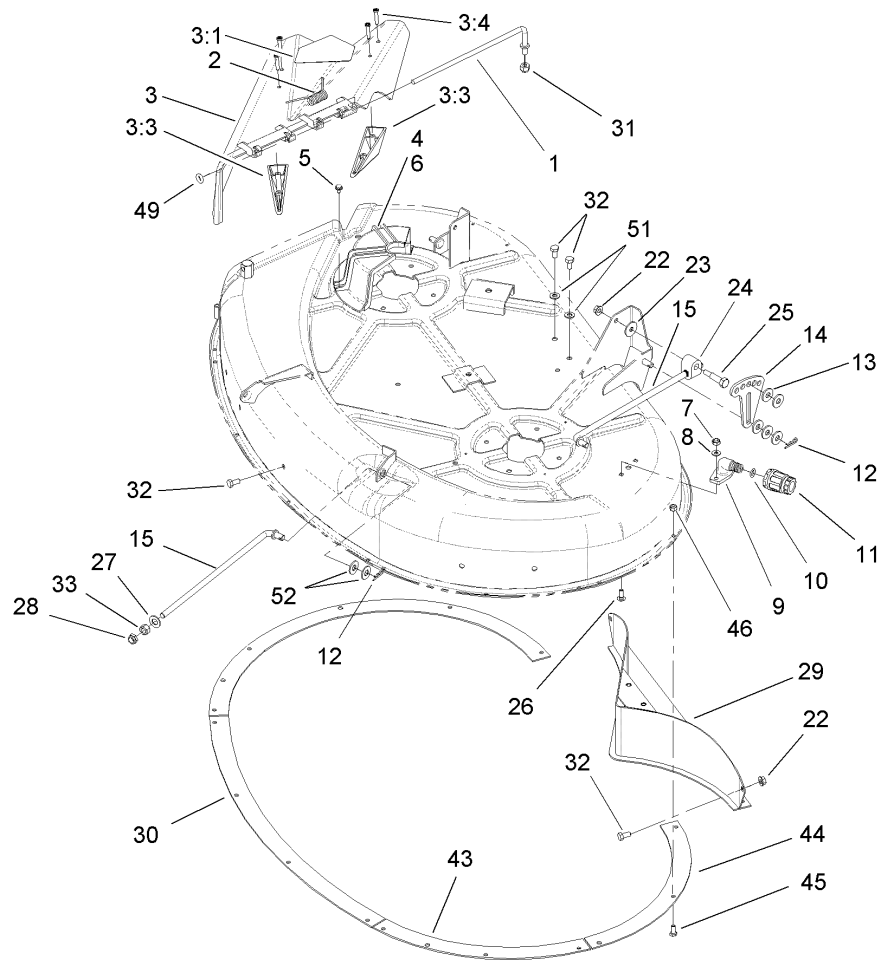

Deflector and Baffle Assembly

Ref	Part No.	Qty.	Description
1	95-1661	1	Rod-Pivot
2	57-6950	1	Spring
3	106-8739	1	42In Deflector ASM
3:1	93-1122	1	Decal-Danger
3:3	93-7696	2	Kicker
3:4	93-0231	4	Screw-PPH
4	88-4030	1	Guide-Belt, Deck (LH)
5	32104-76	5	Screw
6	88-4020	1	Guide-Belt, Deck (RH)
7	3296-16	2	Nut-Lock, NI
8	3256-1	2	Washer-Flat
9	95-2747	1	Fitting-Washout
10	46-6290	1	O-Ring
11	95-3270	1	Connector-Hose
12	9335054	8	Pin-Hair
13	80-6990	10	Washer-Hardened
14	88-5570-03	2	Link-Adjusting, HOC
15	105-3437	4	Rod-Hanger
22	32128-25	4	Nut-HF
23	5-4460	2	Washer-Pivot
24	88-4230	2	Trunnion-HOC
25	7-0030	2	Bolt-Shoulder
26	3229-1	2	Screw-CARR
27	3256-25	2	Washer-Flat

Ref	Part No.	Qty.	Description
28	3296-38	2	Nut-Lock, NI
29	106-6983-03	1	Rear Baffle ASM
30	106-6953-03	1	Ring-Blow Out
31	3296-39	1	Nut-Lock, NI
32	322-2	4	Screw-HH
33	3219-4	2	Nut-Hex
43	106-6952-03	2	Ring-Blow Out, Side
44	106-6954-03	2	Ring-Blow Out, Side
45	321-3	19	Screw-HH
46	3296-42	19	Nut-Lock, NI
49	106-8745	1	O-Ring
51	3256-23	2	Washer-Flat
52	3256-4	8	Washer-Flat

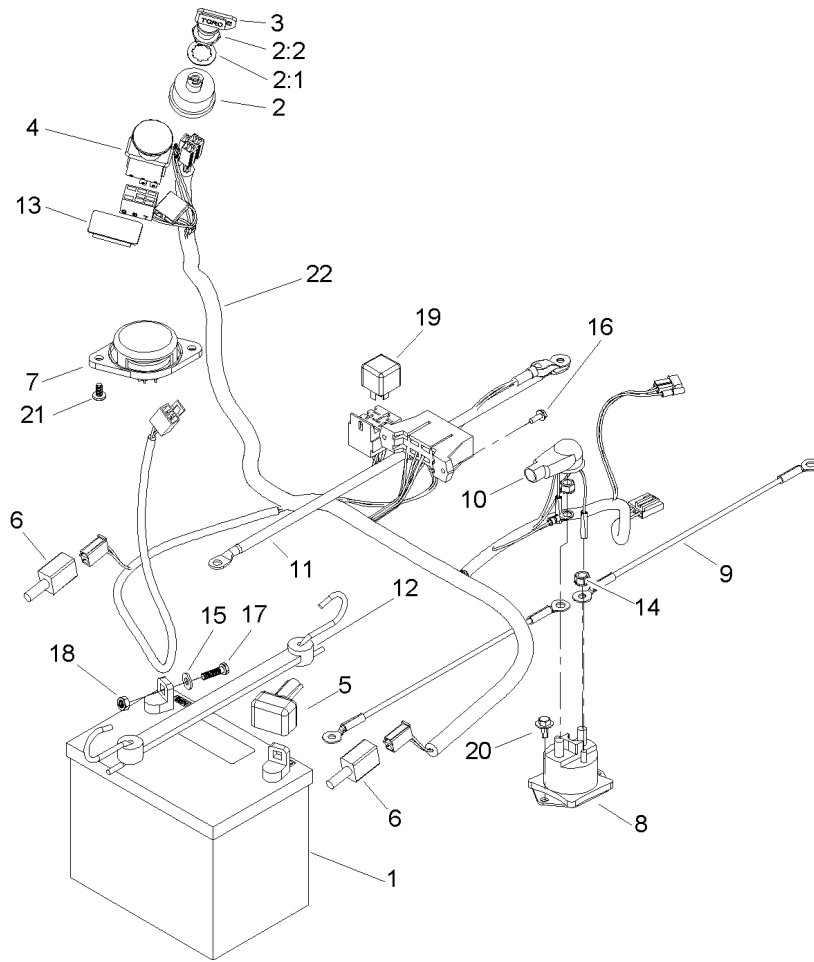

Electrical System Assembly

Ref	Part No.	Qty.	Description
1	104-2491	1	Battery-Dry
2	88-9830	1	Key Switch ASM
2:1	3254-5	1	Washer-Tooth
2:2	218-461	1	Nut-HH
3	63-8360	1	Key-Ignition
4	95-7489	1	Switch-PTO
5	28-8080	1	Boot-Terminal
6	106-2216	2	Switch
7	105-6959	1	Switch-Seat
8	106-8245	1	Solenoid
9	56-7670	2	Wire ASM
10	93-3190	1	Boot-Insulator, Terminal
11	95-7654	1	Cable
12	104-2466	1	Holddown-Battery
13	99-7420	1	Plug-Hole
14	32149-2	2	Nut-Keps
15	3256-22	2	Washer-Flat
16	32144-1	3	Screw-Taptite
17	321-4	2	Screw-HH
18	32128-33	3	Nut-HF
19	98-7249	1	Relay
20	46-8560	2	Screw-HHF
21	105-6968	2	Screw-Seat, Switch
22	107-2500	1	Harness-Wire, 9 Amp

--	--	--	--

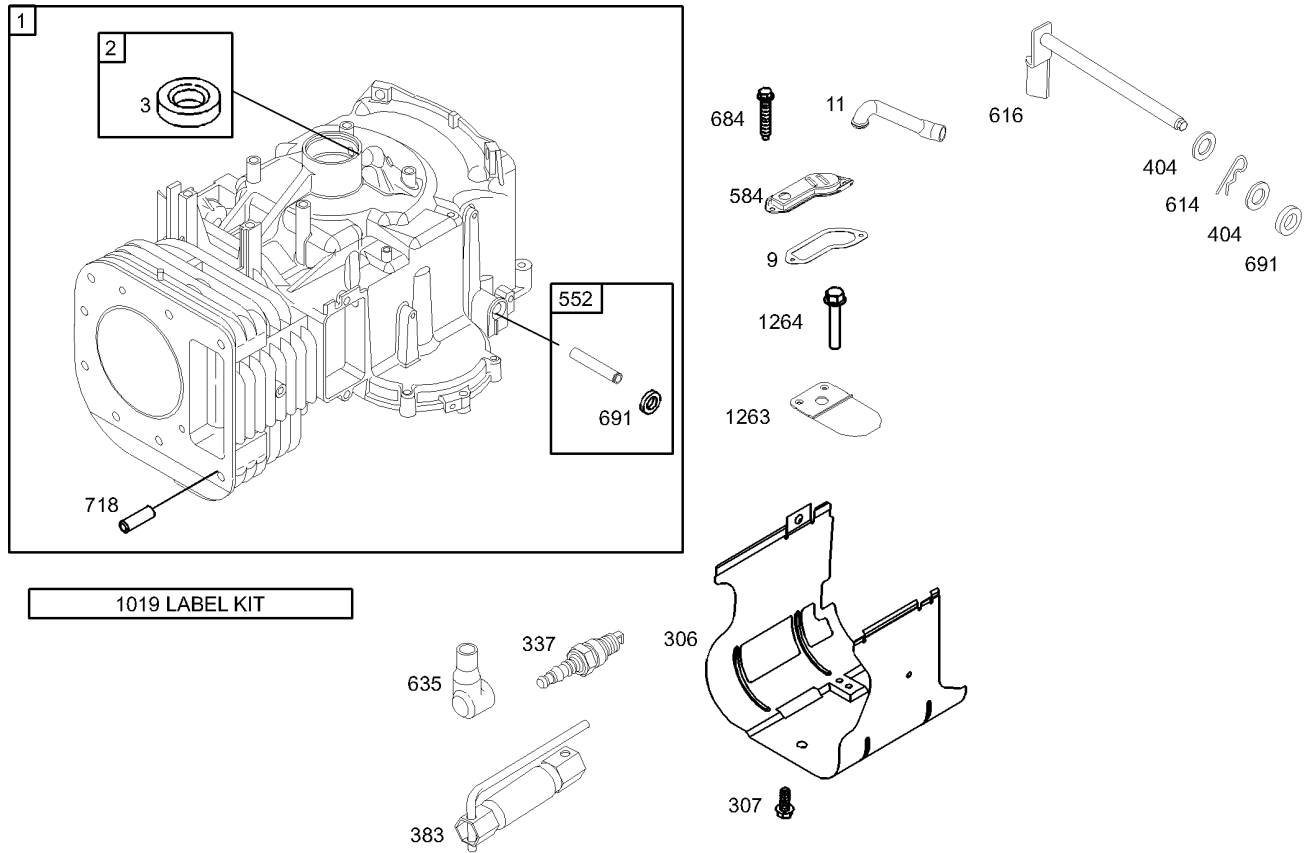

Assemblies include all parts shown in frames.

Cylinder Assembly Briggs and Stratton 286H77-0165-E1

Ref	Part No.	Qty.	Description
1	697132	1	Cylinder ASM
2	399265	1	Bushing And Seal Kit
3	391086	1	Seal-Oil
4	697109	1	Gasket-Breather
5	697113	1	Tube-Breather
6	697762	1	Short Block ASM
7	697107	1	Shield-Cylinder
8	691003	1	Screw
9	691043	1	Spark Plug
10	89838	1	Wrench-Plug, Spark
11	691691	1	Washer
12	697144	1	Bushing-Crank, Governor
13	697112	1	Cover-Passage, Breather
14	691620	1	Pin-Cotter
15	692012	1	Crank-Governor
16	691909	1	Boot-Spark Plug
17	697157	1	Screw
18	692407	1	Seal-Shaft, Governor
19	690959	1	Pin-Locating
20	697143	1	Label Kit
21	697124	1	Reed-Breather
22	697104	1	Screw

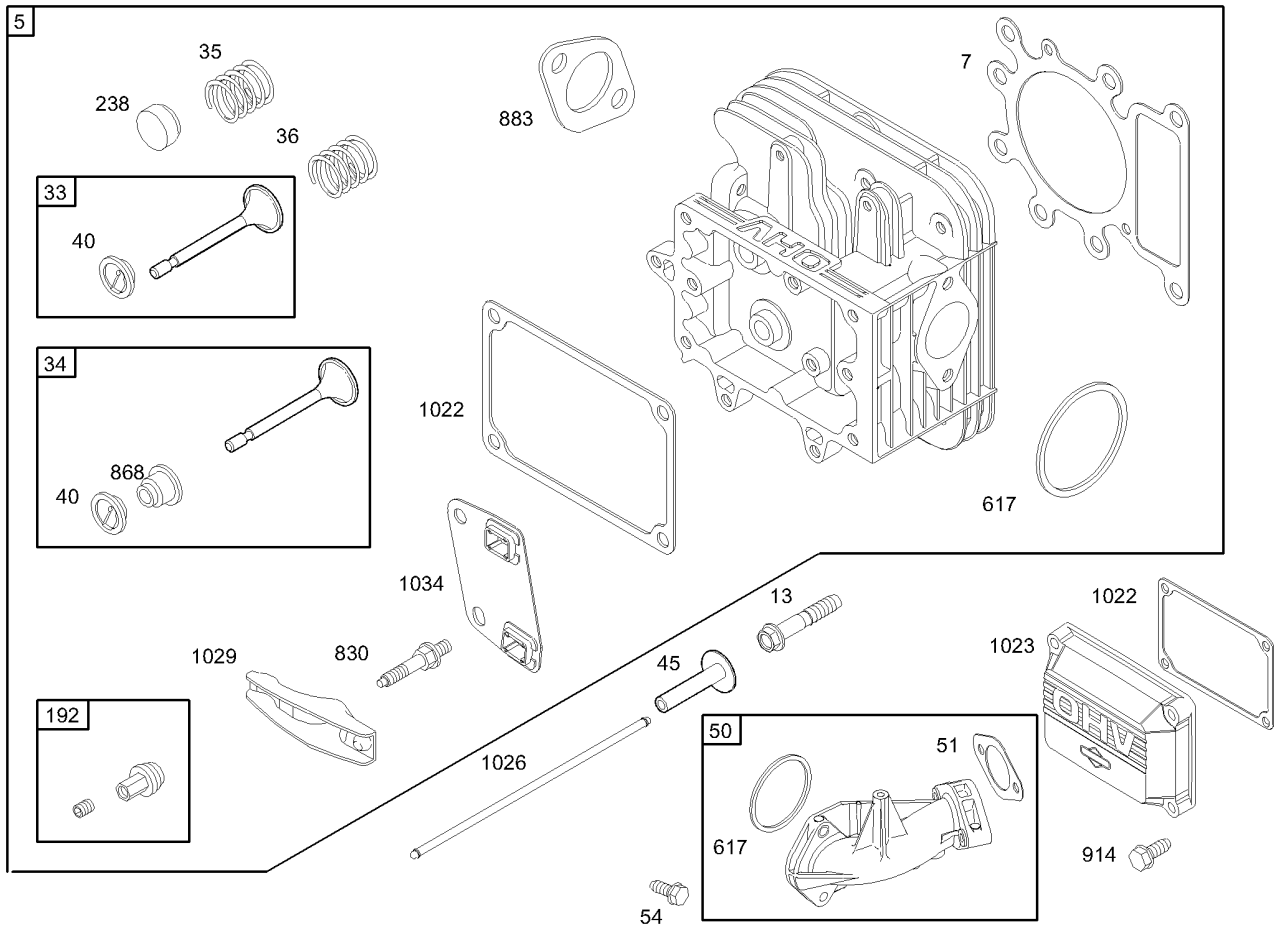

Cylinder Head Assembly Briggs and Stratton 286H77-0165-E1

Ref	Part No.	Qty.	Description
75	698148	1	Head-Cylinder
77	273280	1	Gasket-Head, Cylinder
13	690360	1	Screw
33	695760	1	Valve-Exhaust
34	695761	1	Valve-Intake
35	691279	1	Spring-Valve
36	691279	1	Spring-Valve
40	691752	1	Retainer-Valve
45	690564	1	Tappet-Valve
50	690193	1	Manifold-Intake
51	692137	1	Gasket-Intake
54	691148	1	Screw
192	691986	1	Adjustor-Arm, Rocker
238	691843	1	Cap-Valve
617	692138	1	Seal-O Ring
830	691095	1	Stud-Arm, Rocker
868	690968	1	Seal-Valve
883	692236	1	Gasket-Exhaust
914	690960	1	Screw
1022	272475	1	Gasket-Cover, Rocker
1023	692492	1	Cover-Rocker

Ref	Part No.	Qty.	Description
1026	692003	1	Rod-Push
7	692011	1	Rod-Push
1029	691751	1	Arm-Rocker
1034	690822	1	Guide-Rod, Push

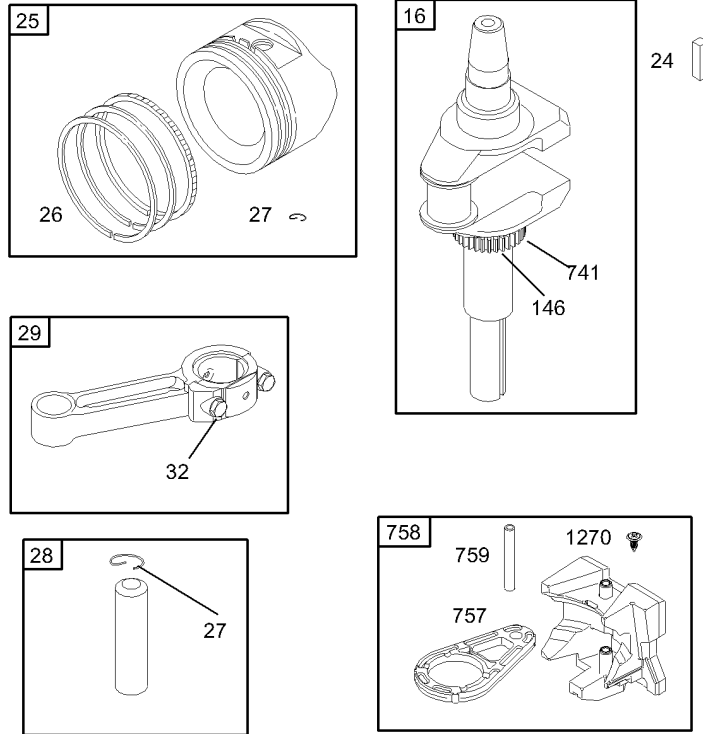

Assemblies include all parts shown in frames.

Crankshaft Assembly Briggs and Stratton 286H77-0165-E1

Ref	Part No.	Qty.	Description
16	697127	1	Crankshaft
24	222698	1	Key
25	697114	1	Piston ASM (Standard)
	697116	1	Piston Assembly (.010In Oversize)
	697117	1	Piston ASM (.020In Oversize)
	697118	1	Piston Assembly (.030In Oversize)
26	697115	1	Ring Set (Standard)
	697119	1	Ring Set (.010" Oversize)
	697120	1	Ring Set (.020In Oversize)
	697121	1	Ring Set (.030" Oversize)
27	698469	1	Lock-Pin, Piston
28	697099	1	Pin-Piston (STD)
29	697126	1	Rod-Connecting (Standard)
	697263	1	Rod-Connecting (.020In Undersize)
32	692852	1	Screw
146	691639	1	Key-Timing
741	697128	1	Gear-Timing
757	697607	1	Link-Counterweight
758	697134	1	Counterweight
759	697392	1	Pin-Counterweight
1270	697156	1	Plug-Counterweight, Avs

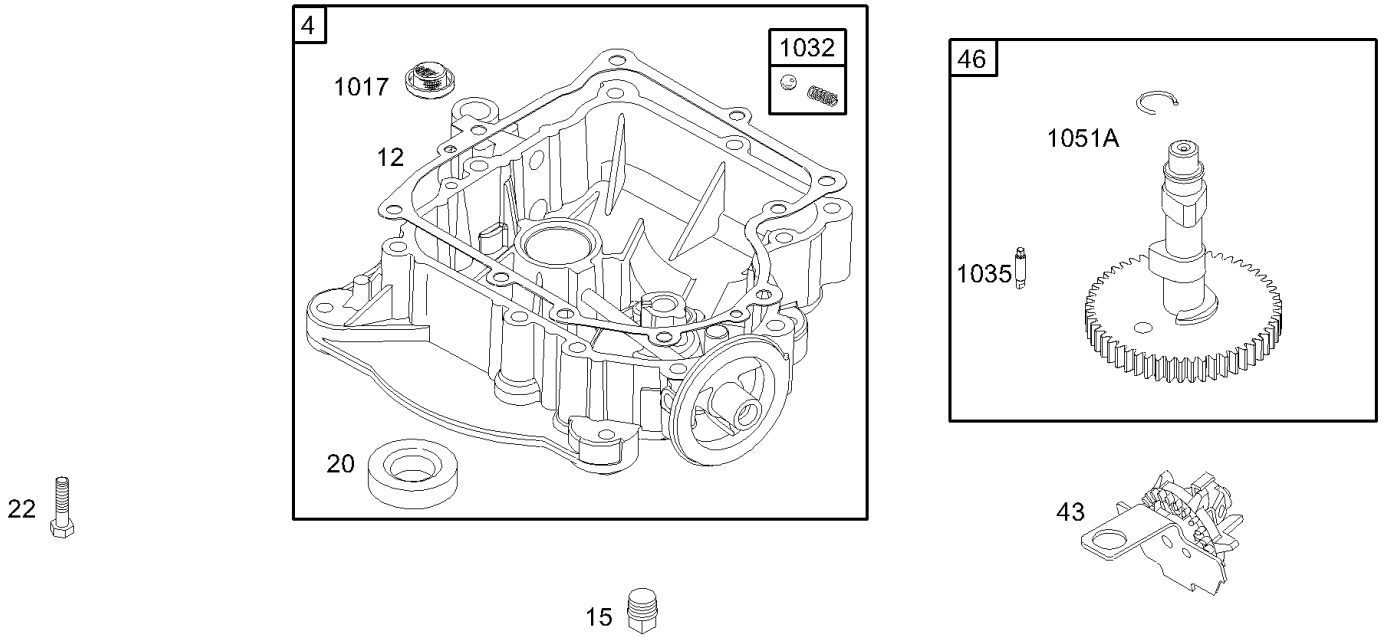

Assemblies include all parts shown in frames.

Crankcase Assembly Briggs and Stratton 286H77-0165-E1

Ref	Part No.	Qty.	Description
④	697188	1	Sump-Engine
③⑦12	697110	1	Gasket-Crankcase
⑦15	690283	1	Plug-Oil
③⑦20	690947	1	Seal-Oil
⑦22	692125	1	Screw
⑦43	691968	1	Slinger-Governor,Oil
⑦46	698577	1	Camshaft
⑦1017	690770	1	Screen-Pump, Oil
⑦1032	491710	1	Ball-Pump, Oil
⑦1035	693784	1	Shaft-Pump, Oil
⑦1051A	698802	1	Ring-Retaining

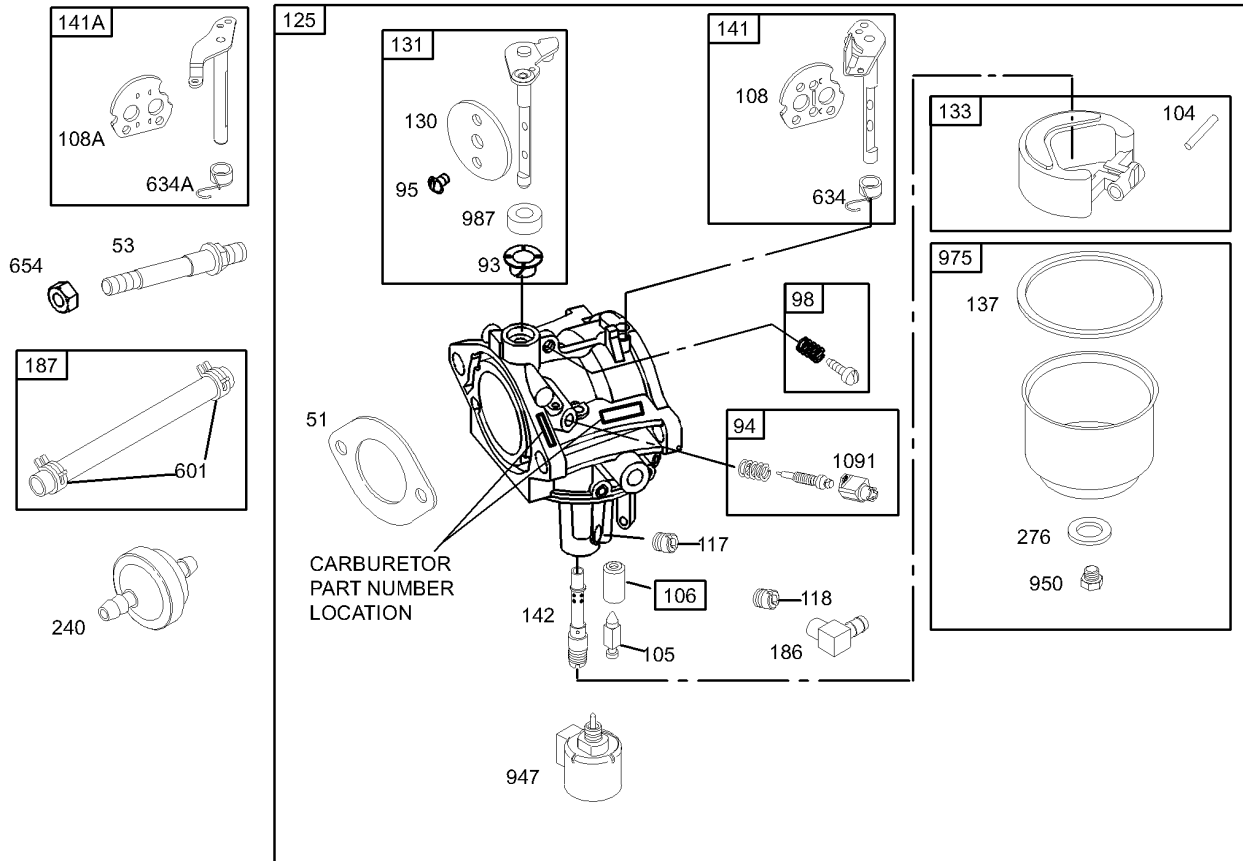

Assemblies include all parts shown in frames.

Carburetor Assembly Briggs and Stratton 286H77-0165-E1

Ref	Part No.	Qty.	Description
5 4 51	692137	1	Gasket-Intake
5 6			
7 53	690227	1	Stud
5 7 93	690602	1	Bushing-Shaft, Throttle
7 94	498030	1	Idle Mixture Kit
5 7 95	691636	1	Screw
7 98	495800	1	Idle Speed Kit
5 7 104	690525	1	Pin-Hinge, Carburetor Float
5 7 105	231855	1	Valve-Needle, Float
5 7 106	690577	1	Seat-Inlet
7 108	690464	1	Valve-Choke
7 108A	692344	1	Valve-Choke
5 7 117	694352	1	Jet-Main (STD)
7 118	697228	1	Jet-Main (High Altitude)
7 125	697190	1	Carburetor
7 130	691750	1	Valve-Throttle
7 131	494379	1	Throttle Shaft Kit
7 133	494381	1	Float-Carburetor
5 6 137	281165	1	Gasket-Bowl, Float
7			
7 141	495097	1	Choke Shaft Kit
7 141A	495931	1	Choke Shaft Kit
5 7 142	697140	1	Nozzle-Carburetor
7 186	692317	1	Connector-Hose

Ref	Part No.	Qty.	Description
7 187	697098	1	Line-Fuel
7 240	394358	1	Filter-Fuel
5 6 276	692255	1	Washer-Sealing
7			
7 601	95162	1	Clamp-Hose
5 7 634	690801	1	Spring / Seal ASM
5 7 634A	690802	1	Spring And Seal ASM
7 654	690958	1	Nut
7 947	694393	1	Solenoid-Fuel
7 950	691657	1	Screw
7 975	495933	1	Bowl-Float
5 7 987	691326	1	Seal-Shaft, Throttle
7 1091	691333	1	Cap-Limiter

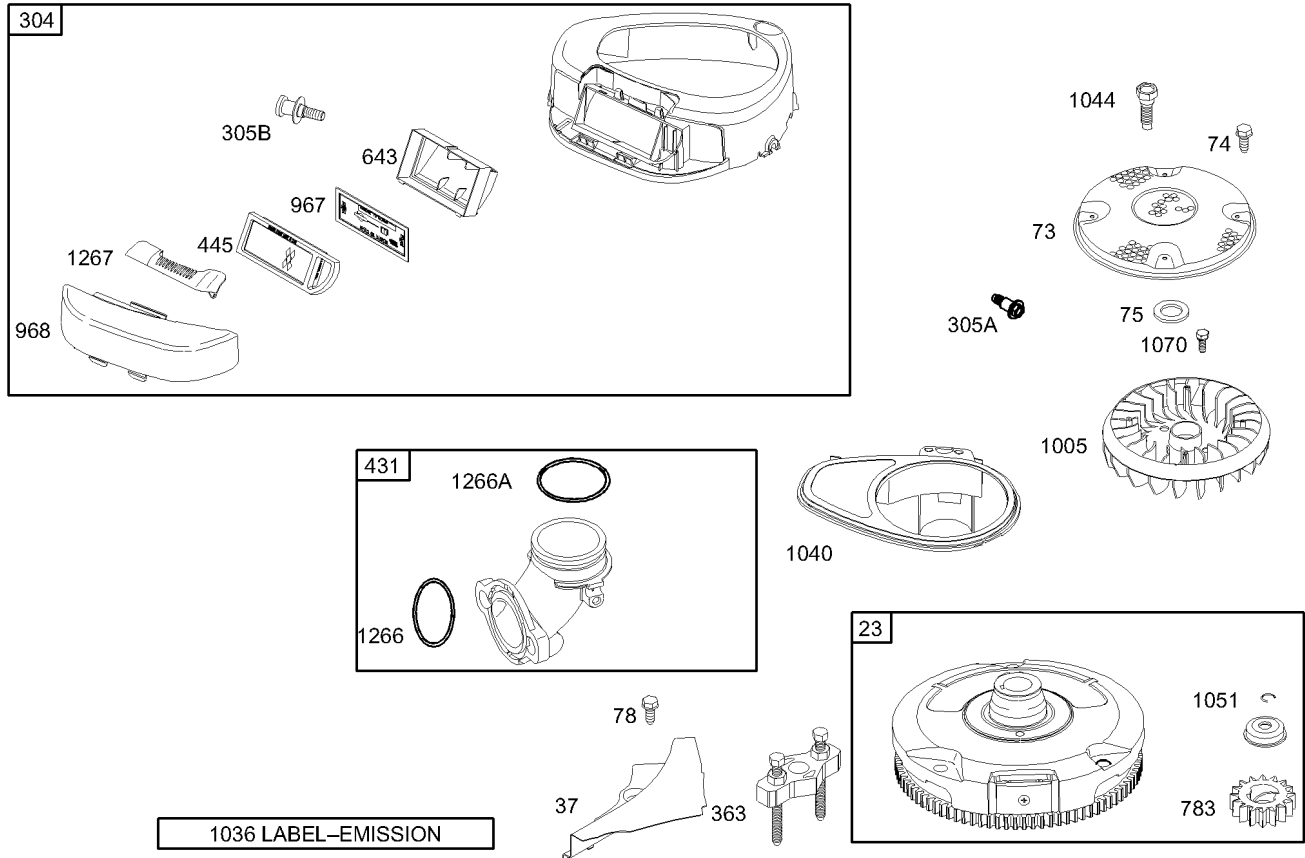

Assemblies include all parts shown in frames.

Blower Housing Assembly Briggs and Stratton 286H77-0165-E1

Ref	Part No.	Qty.	Description
23	693556	1	Flywheel
37	697352	1	Guard-Flywheel
73	697384	1	Screen-Rotating
74	697897	1	Screw
75	690582	1	Washer-Flywheel
78	691003	1	Screw
304	698804	1	Housing-Blower
305A	697103	1	Screw
305B	697102	1	Screw
363	19203	1	Puller-Flywheel
431	697122	1	Elbow-Intake
445	698083	1	Filter-Cartridge, Air Cleaner
643	698401	1	Retainer-Filter, Air
783	693713	1	Gear-Pinion
967	697015	1	Filter-Cleaner, Pre
968	697084	1	Cover-Cleaner, Air
1005	697853	1	Fan-Flywheel
1036	695700	1	Label-Emission
1040	698368	1	Plate-Trim
1044	691658	1	Screw-Crankshaft Extension
1051	691265	1	Ring-Retaining
1070	690372	1	Screw
1266	691917	1	Seal-O Ring
1266A	697123	1	Seal-O Ring

Ref	Part No.	Qty.	Description
1267	697135	1	Latch-Blower Housing

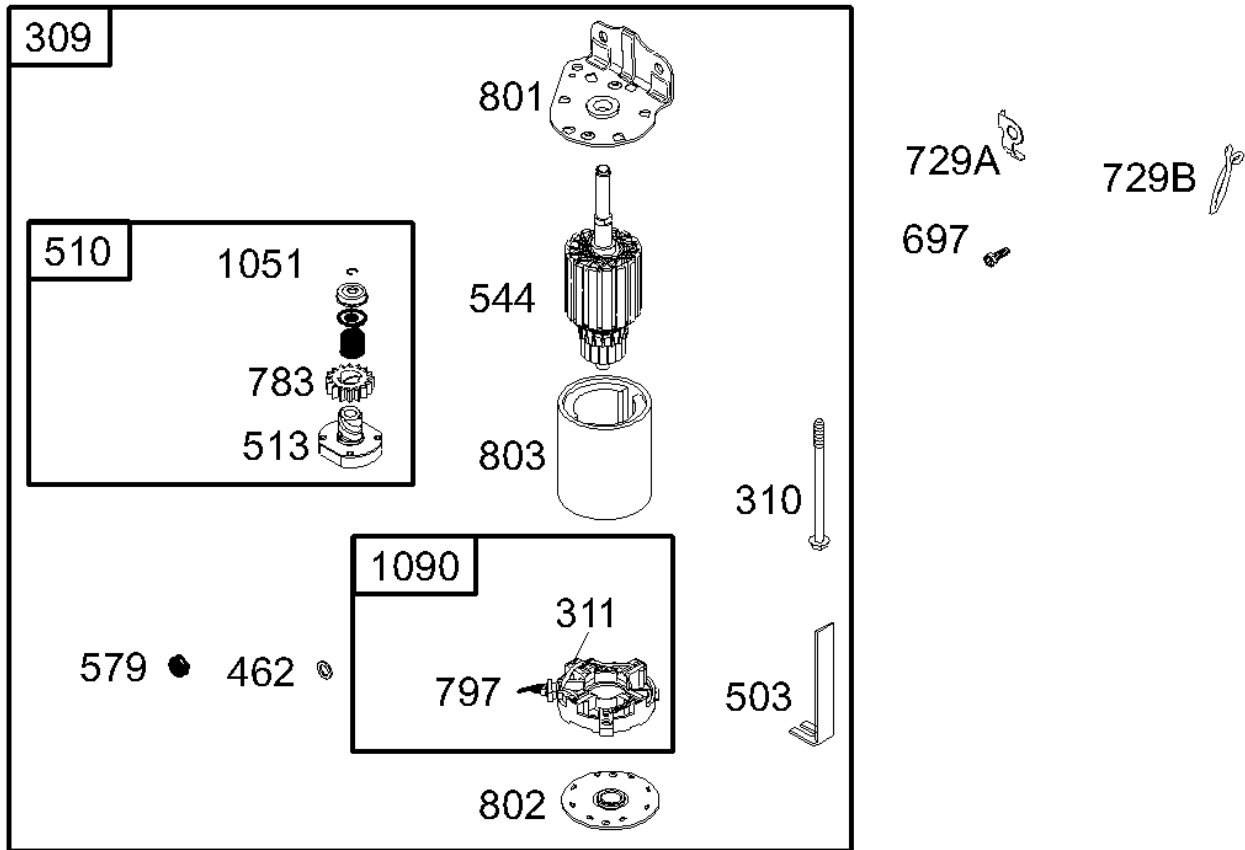

Starter Assembly Briggs and Stratton 286H77-0165-E1

Ref	Part No.	Qty.	Description
309	693551	1	Motor-Starter
310	690323	1	Bolt
311	497608	1	Brush Set
462	691261	1	Washer
503	691532	1	Strap-Starter
510	693699	1	Drive-Starter
513	692024	1	Clutch-Drive
544	692034	1	Armature-Starter
579	691029	1	Nut
697	690372	1	Screw
729A	691224	1	Clip-Wire
729B	694123	1	Clip-Wire
783	693713	1	Gear-Pinion
797	693167	1	Nut
801	691283	1	Cap-Drive
802	691286	1	Cap-End
803	693757	1	Housing-Starter
1051	691265	1	Ring-Retaining
1090	691293	1	Retainer-Brush

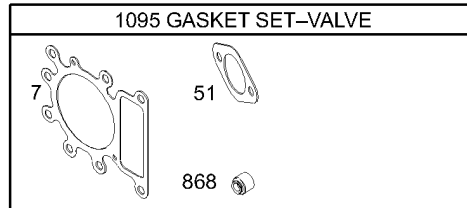
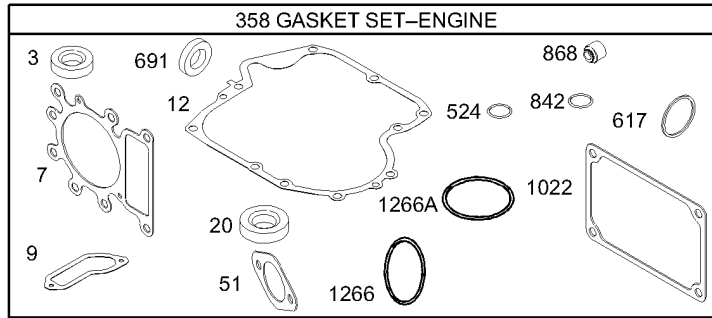

Assemblies include all parts shown in frames.

Gasket Assembly Briggs and Stratton 286H77-0165-E1

Ref	Part No.	Qty.	Description
373	391086	1	Seal-Oil
377	273280	1	Gasket-Head, Cylinder
379	697109	1	Gasket-Breather
3712	697110	0	Gasket-Crankcase
3720	690947	1	Seal-Oil
451	692137	1	Gasket-Intake
358	697151	1	Engine Gasket Set
4617	692138	1	Seal-O Ring
37524	691032	1	Seal, O-Ring
37691	692407	1	Seal-Shaft, Governor
37842	691031	1	Seal-O Ring
3868	690968	1	Seal-Valve
371022	272475	1	Gasket-Cover, Rocker
71095	691581	1	Valve Gasket Set
31266	691917	1	Seal-O Ring
31266A	697123	1	Seal-O Ring

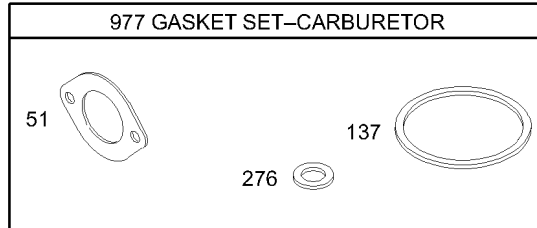
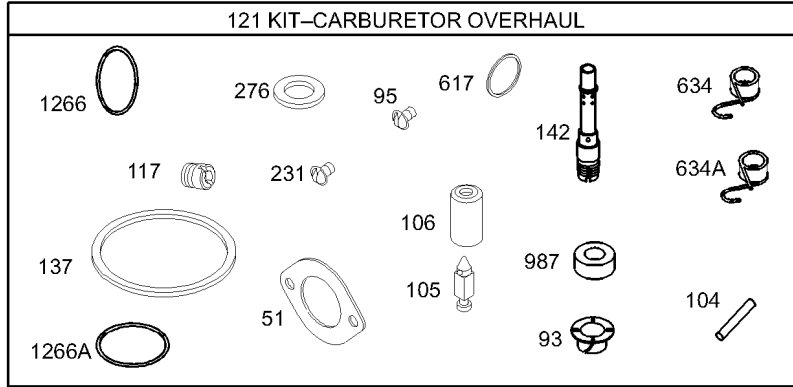

Assemblies include all parts shown in frames.

Carburetor Overhaul Kit Assembly Briggs and Stratton 286H77-0165-E1

Ref	Part No.	Qty.	Description
⑤④51 ⑤⑥	692137	1	Gasket-Intake
⑤⑦93	690602	1	Bushing-Shaft, Throttle
⑤⑦95	691636	1	Screw
⑤⑦104	690525	1	Pin-Hinge, Carburetor Float
⑤⑦105	231855	1	Valve-Needle, Float
⑤⑦106	690577	1	Seat-Inlet
⑤⑦117	694352	1	Jet-Main (STD)
⑦121	697154	1	Carburetor Overhaul Kit
⑤⑥137 ⑦	281165	1	Gasket-Bowl, Float
⑤⑦142	697140	1	Nozzle-Carburetor
⑤⑦231	691636	1	Screw
⑤⑥276 ⑦	692255	1	Washer-Sealing
⑤⑤617 ⑦	692138	1	Seal-O Ring
⑤⑦634	690801	1	Spring / Seal ASM
⑤⑦634A ⑦977	690802	1	Spring And Seal ASM
⑤⑦987	690192	1	Carburetor Gasket Set
⑤⑦987	6916326	1	Seal-Throttle Shaft
⑤⑤1266 ⑦	691917	1	Seal-O Ring
⑤⑤1266A ⑦	697123	1	Seal-O Ring

NOTES

