



## TimeCutter™ ZX440 Riding Mower

Model No. 74603 - 260000001 and up.

### Parts Catalog

---

#### Ordering Replacement Parts

To order replacement parts, please supply the part number, the quantity, and the description of each part desired.

#### Understanding Reference Numbers

Each identified part in an illustration has a reference number. The reference number for a part also appears in the parts list, along with other information about the part.

This catalog uses two special reference number formats, one to indicate parts in a service assembly and another to indicate the quantity of a given part in an illustration.

#### Service Assembly Reference Numbers

Parts in service assemblies have reference numbers in the form a:b. The a represents the reference number of the entire service assembly and the b represents a sequential number unique to each part within the service assembly.

For example, a wheel assembly might be identified by reference number 6, the tire by 6:1, the valve by 6:2, and the wheel by 6:3. When you order the assembly identified by reference number 6, you receive all parts identified by reference numbers 6:1, 6:2, and 6:3. However, you may also order any part individually. Reference numbers of this type appear in illustrations and in part lists.

#### Reference Numbers Indicating Quantity

In an illustration, if a reference number indicates more than one part, the reference number has the form nX y. The n represents the quantity of the part, the X is the multiplication symbol, and the y represents the reference number.

For example, in an illustration, the reference number 2X 37 means that two of the parts identified by reference number 37 are indicated.

# Contents

Description	Page	Description	Page
Front Frame Assembly	3	Air Intake and Filtration Assembly Kohler Cv492s-27525	21
Height-of-Cut Handle and Plate Assembly	4	Exhaust Assembly Kohler Cv492s-27525	22
Main Frame Assembly	5	Crankcase Assembly Kohler Cv492s-27525	23
Fuel Tank and Control Pod Assembly	6	Oil Pan and Lubrication Assembly Kohler Cv492s-27525	24
Parking Brake Assembly	7	Head, Valve and Breather Assembly Kohler Cv492s-27525	25
Motion Control System Assembly	8	Ignition and Electrical Assembly Kohler Cv492s-27525	26
Hydro and Belt Drive Assembly	9	Blower Housing and Baffle Assembly Kohler Cv492s-27525	27
LH Hydro Assembly No. 108-8507	10	Starter Assembly Kohler Cv492s-27525	28
RH Hydro Assembly No. 108-8506	12	Fuel System Assembly Kohler Cv492s-27525	29
Engine and Clutch Assembly	14	Engine Control Assembly Kohler Cv492s-27525	30
Electrical Assembly	15	Attachments and Accessories List	31
44 Inch Deck Assembly	16		
44 Inch Deck Assembly No. 105-1948	17		
Deflector Assembly No. 108-8591	18		
44in Deck Belt Drive Assembly	19		
Crankshaft Assembly Kohler Cv492s-27525	20		

## Part Description Abbreviations

Part descriptions in this catalog may include the following abbreviations.

AR. .... as required	HYD. .... hydraulic
ASM. .... assembly	LH. .... left hand
BBC. .... blade brake clutch	NI. .... nylon insert
CARR. .... carriage	NPTF. .... national pipe thread fine
DEG. .... degrees	PFH. .... phillips flat head
EXT. .... external	PPH. .... phillips pan head
FH. .... flat head	PPHTF. .... phillips pan head thread forming
GA. .... gauge	PRH. .... phillips round head
HD. .... heavy-duty	PTH. .... phillips truss head
HF. .... hex flange	PTO. .... power-take-off
HH. .... hex head	RH. .... right hand
HHF. .... hex head flange	ROPS. .... roll-over protection system
HHFTF. .... hex head flange thread forming	SFH. .... slotted fillister head
HJ. .... hex jam	SHH. .... slotted hex head
HLH. .... hex lag head	SHWH. .... slotted hex washer head
HOC. .... height-of-cut	SPH. .... slotted pan head
HSBH. .... hex socket button head	SQH. .... square head
HSFH. .... hex socket flat head	SRH. .... slotted round head
HSH. .... hex socket head	STD. .... standard
HWH. .... hex washer head	TAP. .... self tapping
HWHTF. .... hex washer head thread forming	TTH. .... torx truss head

## Footnotes

- ❶ Not illustrated
- ❸ Obtain from your local Kohler dealer

- ❷ Not serviced separately

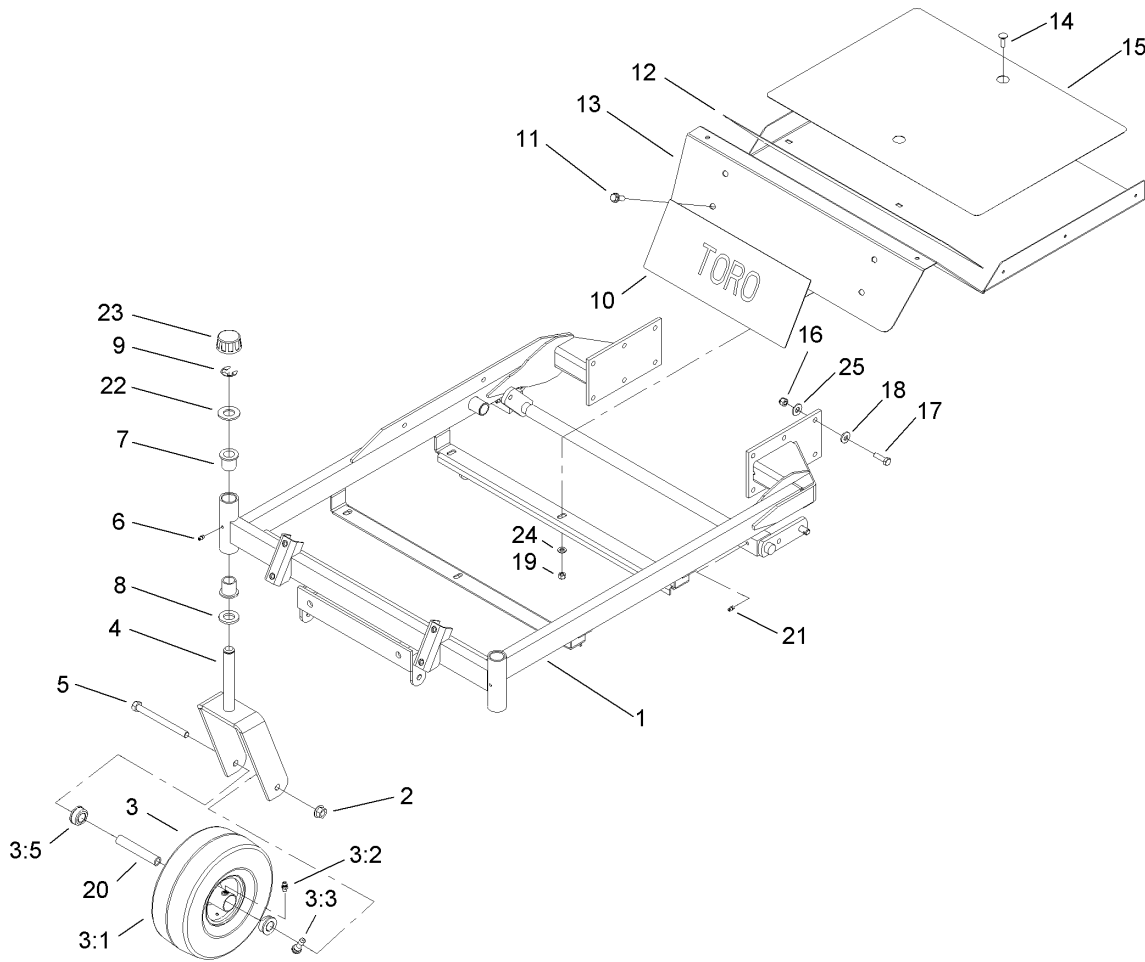

## Front Frame Assembly

Ref	Part No.	Qty.	Description
1	108-2311-01	1	Carrier Frame ASM
2	32128-23	2	Nut-HF
3	105-3471	2	Front Wheel And Tire ASM
3:1	105-1943	1	Tire
3:2	302-5	1	Fitting-Grease
3:3	232-27	1	Stem-Valve
3:5	114-1640	2	Bushing-Flange
①3:99	93-4244	1	Tube-Inner (W/Valve)
4	100-7363-01	2	Caster Fork ASM
5	325-22	2	Screw-HH
6	302-5	2	Fitting-Grease
7	1-303514	4	Bearing-Flanged
8	1-513338	2	Washer-Flat
9	32151-103	2	Ring-Snap
10	67-7320	1	Decal
11	66-9300	4	Screw-HF
12	104-3639	1	Pad-Skid, Anti
13	100-7386-03	1	Floorpan
14	3230-28	6	Screw-CARR
15	104-3640	1	Pad-Skid, Anti
16	3296-39	12	Nut-Lock, NI
17	323-7	12	Screw-HH
18	98-5975	12	Washer-Belleville
19	3296-29	6	Nut-Lock, NI

Ref	Part No.	Qty.	Description
20	104-3667	2	Spanner-Wheel
21	302-19	2	Fitting-Grease
22	104-8076	2	Washer
23	61-9780	2	Cap-Hub
24	3256-23	6	Washer-Flat
25	1-809107	12	Washer-Hardened

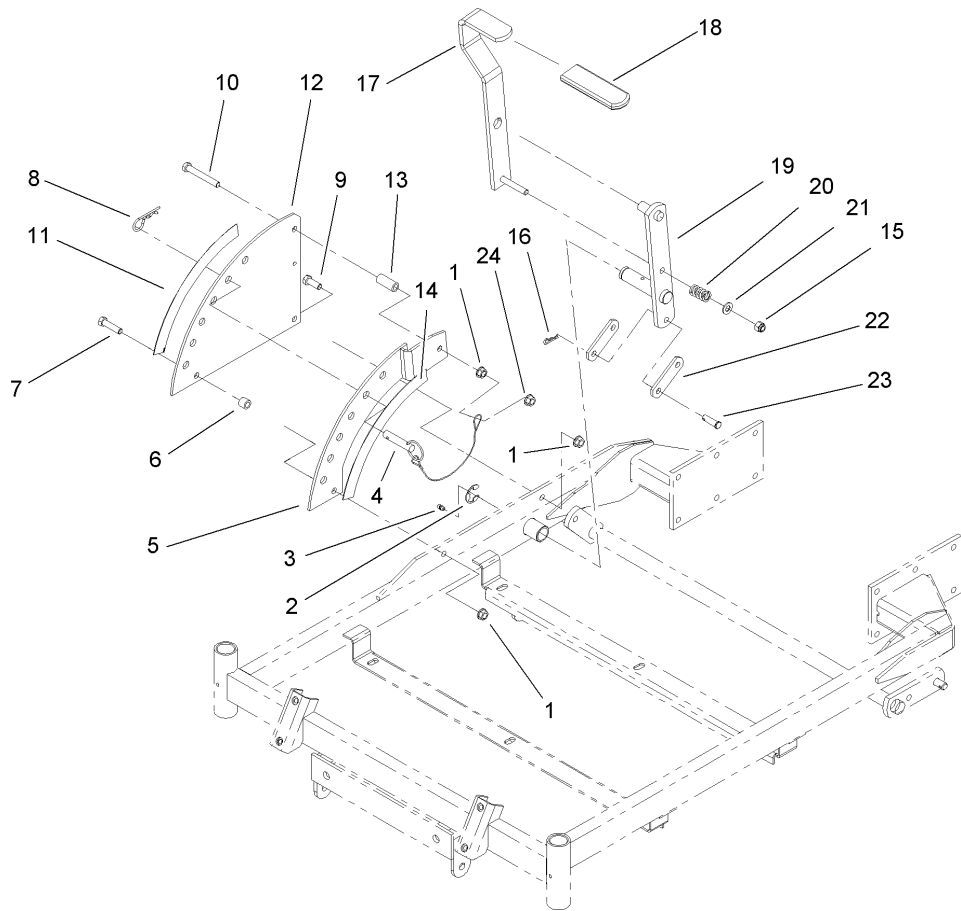

## Height-of-Cut Handle and Plate Assembly

Ref	Part No.	Qty.	Description
1	3290-357	3	Nut-HHF, Whiz
2	32151-103	1	Ring-Snap
3	302-5	1	Fitting-Grease
4	104-3678	1	Pin-Hitch
5	100-7335-01	1	Plate-Lift
6	1-413088	1	Bushing-Lever, Lift
7	323-8	1	Screw-HH
8	1-806005	1	Pin-Hair
9	323-6	1	Screw-HH
10	323-13	1	Screw-HH
11	104-3641	1	Decal-Deck Height, Outer
12	100-7384-01	1	Plate-Deck Lift
13	1-633082	1	Bushing-Lever, Lift
14	104-8032	1	Decal-Deck Height, Inner
15	3296-39	1	Nut-Lock, NI
16	1-806003	2	Pin-Hair
17	1-652023-03	1	Lever-Lift
18	1-633295	1	Grip-Lever, Lift
19	1-652027-03	1	Arm-Deck, Lift
20	1-633325	1	Spring-Compression
21	3256-24	1	Washer-Flat
22	1-633068	2	Arm-Lift, Deck
23	283-2	2	Pin-Clevis
24	32128-21	1	Nut-HF

--	--	--	--

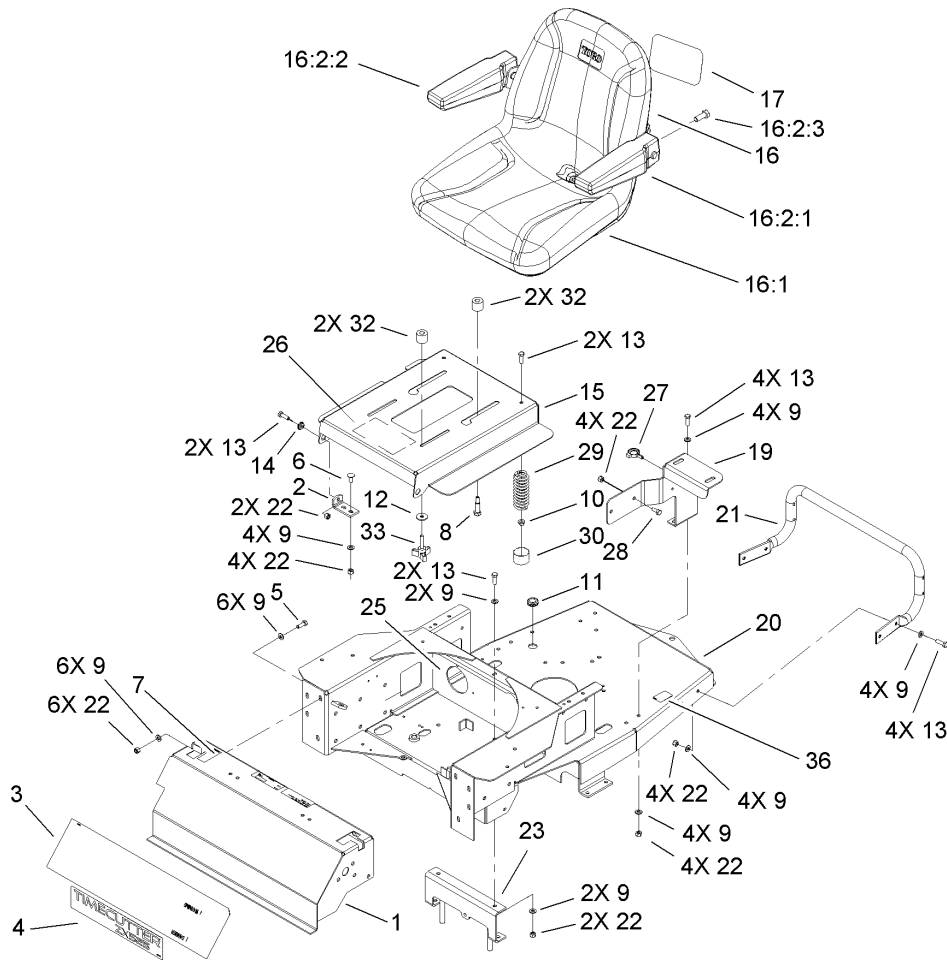

## Main Frame Assembly

Ref	Part No.	Qty.	Description
1	104-8040-03	1	Console
2	104-8057-03	2	Bracket-Pivot
3	107-7399	1	Decal-Danger
4	108-7130	1	Decal
5	322-4	6	Screw-HH
6	3230-23	4	Screw-CARR
7	1-633354	2	Decal-Control, Motion
8	7-0030	2	Bolt-Shoulder
9	3256-23	36	Washer-Flat
10	32128-25	2	Nut-HF
11	237-124	1	Grommet
12	5-4460	2	Washer-Pivot
13	322-5	14	Screw-HH
14	105503	2	Bushing
15	108-9572-03	1	Seat Pan ASM
16	106-6447	1	Seat (With Arm Rests)
16:1	108-2329	1	Seat
16:2	108-6163	1	Armrest Kit
16:2:1	108-6177	1	LH Armrest ASM
16:2:2	108-6178	1	RH Armrest ASM
16:2:3	108-6179	6	Screw-HSBH
17	93-7340	1	Decal
18	100-7376-01	1	Bracket-RH
19	100-7368-01	1	Bracket-LH

Ref	Part No.	Qty.	Description
20	108-2310-01	1	Rear Frame ASM
21	100-7332-03	1	Rod-Support, Rear
22	3296-29	26	Nut-Lock, NI
23	105-6987-03	1	Bracket
25	105-1854	1	Cover-Conduit
26	107-2473	1	Decal-Service
27	105-1853	2	Clamp-Hose
28	322-3	4	Screw-HH
29	92-7054	2	Spring-Compression
30	701178	2	Cap-Protector
32	108-2327	4	Spacer
33	108-2356	2	Knob
36	106-0699	1	Decal-Warning

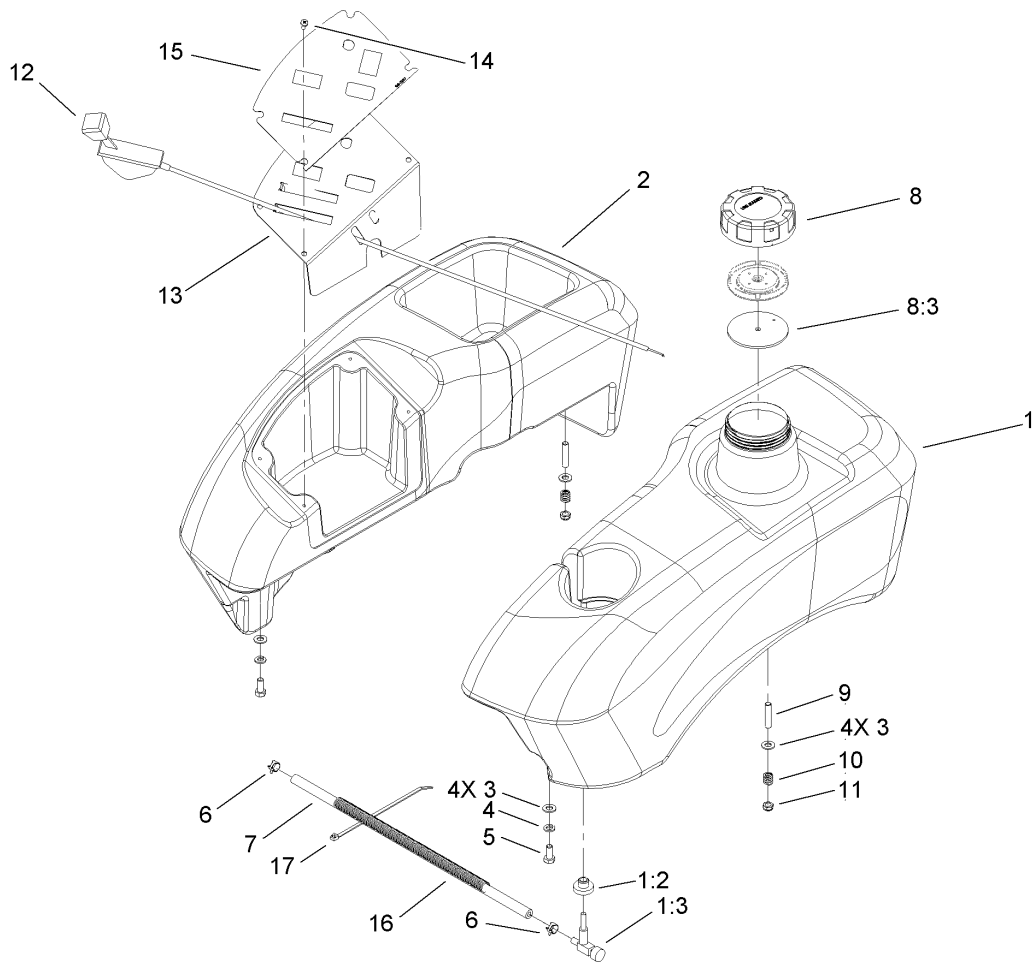

## Fuel Tank and Control Pod Assembly

Ref	Part No.	Qty.	Description
1	105-3494	1	Fuel Tank ASM
1:2	46-6560	1	Bushing
1:3	104048	1	Valve-Fuel
2	105-1918	1	Tank-Console
3	3256-23	8	Washer-Flat
4	3253-4	4	Washer-Lock
5	322-3	4	Screw-HH
6	2412-98	2	Clamp
7	109-0299	1	Hose-Fuel
8	88-3980	1	Gas Cap ASM
8:3	88-4010	1	Gasket-Cap, Gas
9	1-633023	4	Stud
10	1-633349	4	Spring-Tank, Fuel
11	3296-47	4	Nut-Lock, NI
12	104-8007	1	Cable-Throttle
13	104-3664-03	1	Panel-Control
14	3250-14	4	Screw-PPH
15	104-8009	1	Decal-Panel, Control
16	105-1854	1	Cover-Conduit
17	614249	1	Strap-Tie

--	--	--	--

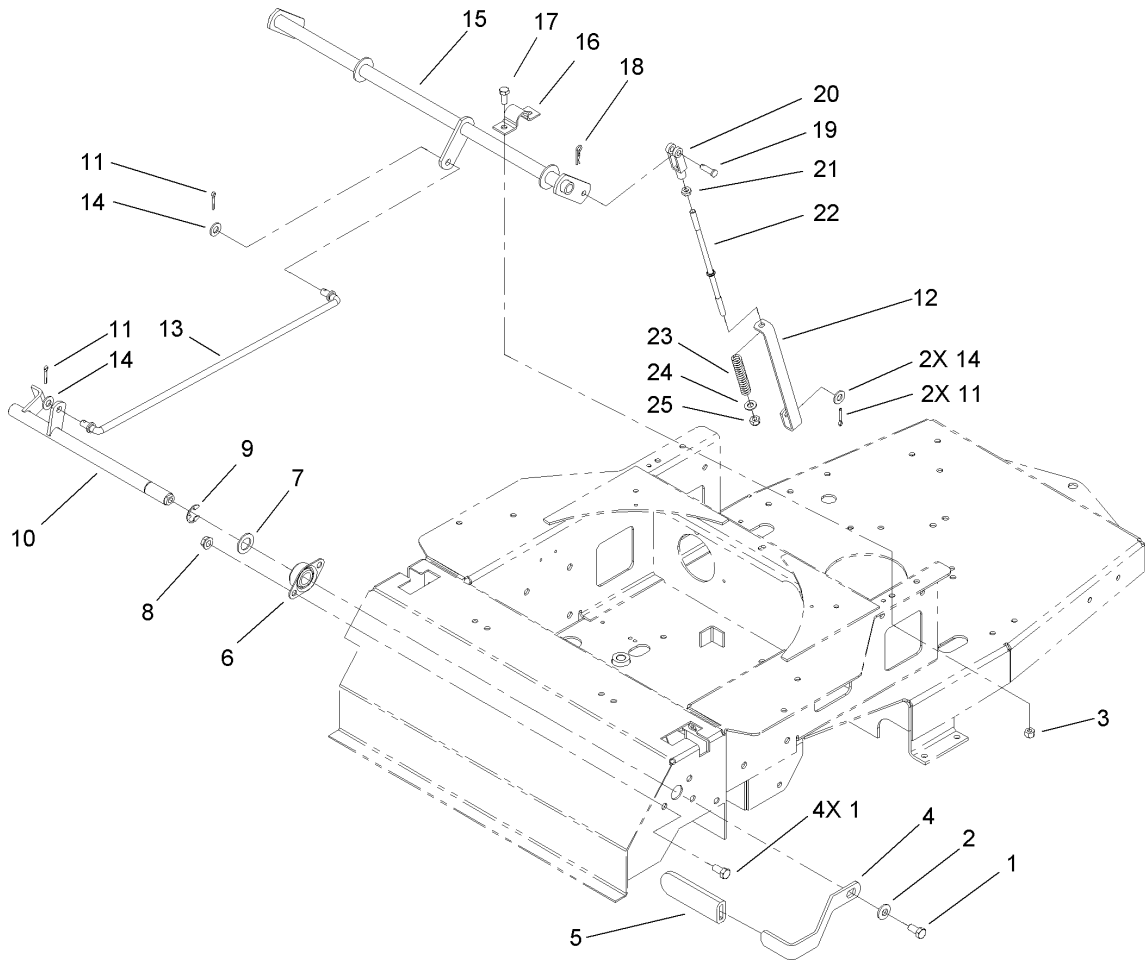

## Parking Brake Assembly

Ref	Part No.	Qty.	Description
1	323-4	5	Screw-HH
2	98-5975	1	Washer-Belleville
3	3296-29	4	Nut-Lock, NI
4	100-7346-03	1	Handle-Brake, Park
5	1-633268	1	Grip-Lever, Brake
6	1-633102	2	Bearing-Flange, Side
7	1-303007	1	Washer
8	3290-357	4	Nut-HHF, Whiz
9	32151-48	1	E-Ring
10	100-7318	1	Brake Shaft ASM
11	3272-10	4	Pin-Cotter
12	104-3675	2	Bracket-Spring, Brake
13	104-8046	1	Rod-Brake, Upper
14	3256-24	4	Washer-Flat
15	104-3670-03	1	Shaft-Brake
16	88-4730	2	Clamp-Pivot, HOC
17	322-3	4	Screw-HH
18	1-806003	2	Pin-Hair
19	1-808280	2	Pin-Clevis
20	1-303105	2	Yoke-Adjustable
21	3219-2	2	Nut-Hex
22	104-3674	2	Rod-Brake, Upper
23	38-4520	2	Spring
24	3256-23	2	Washer-Flat

Ref	Part No.	Qty.	Description
25	3296-4	2	Nut-Lock

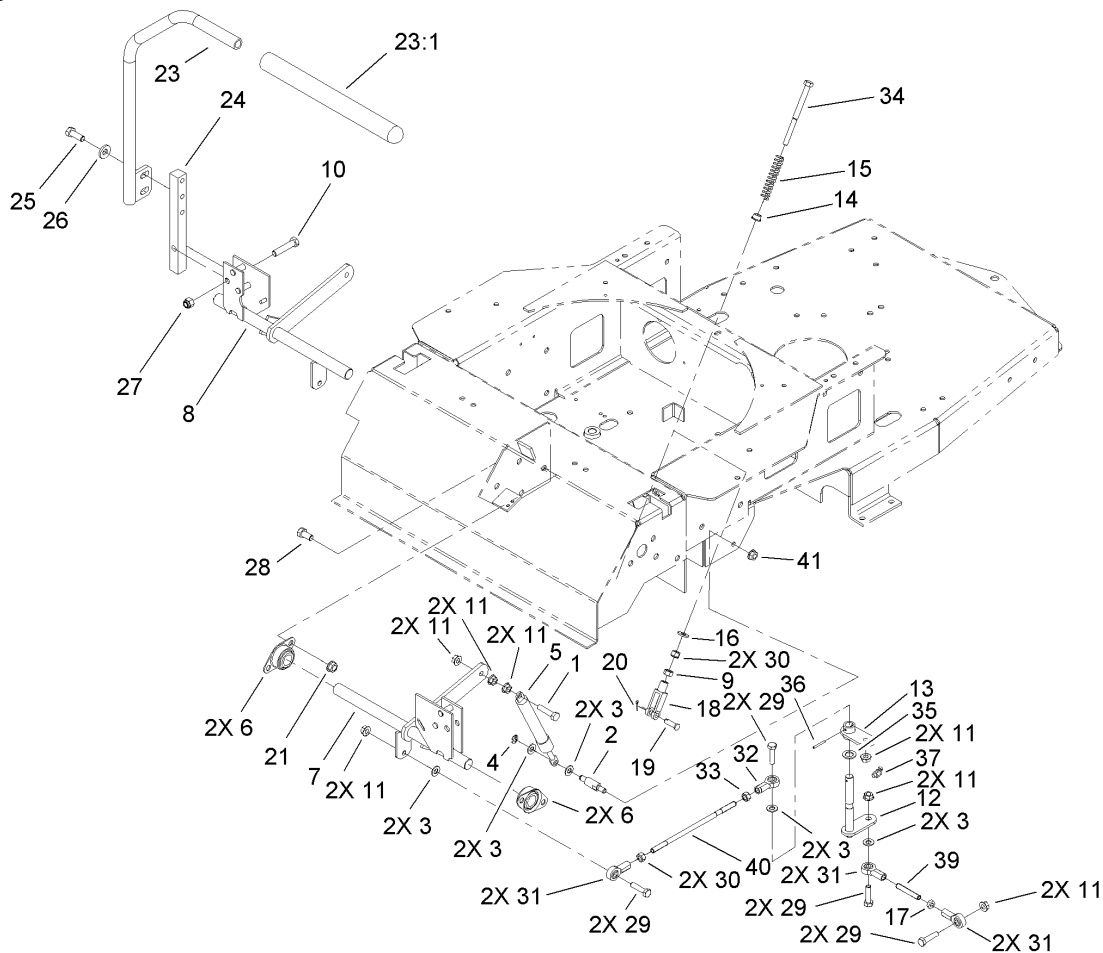

## Motion Control System Assembly

Ref	Part No.	Qty.	Description
1	1-403180	2	Screw-HH
2	1-653316	2	Pin-Damper
3	3256-23	10	Washer-Flat
4	32120-35	2	Ring-Retaining, EXT
5	103-2913	2	Damper-Control, Motion
6	1-633102	4	Bearing-Flange, Side
7	100-7341	1	Bracket-Motion Control, LH
8	100-7340	1	Bracket-Motion Control, RH
9	3296-4	2	Nut-Lock
10	323-9	2	Screw-HH
11	32128-20	14	Nut-HF
12	100-7311	2	Pivot ASM
13	100-7313	2	Pivot Plate ASM
14	1-603735	2	Bushing-Flanged
15	1-603807	2	Spring-Return, Neutral
16	3256-2	2	Washer-Flat
17	3220-2	2	Nut-Jam
18	1-303105	2	Yoke-Adjustable
19	1-808280	2	Pin-Clevis
20	3272-5	2	Pin-Cotter
21	3290-357	6	Nut-HHF, Whiz
22	103-0631	1	LH Lever ASM
22:1	1-633257	1	Grip-Control, Motion
23	103-0632	1	RH Lever ASM

Ref	Part No.	Qty.	Description
23:1	1-633257	1	Grip-Control, Motion
24	103-0407	2	Arm-Shaft, Control
25	323-6	4	Screw-HH
26	98-5975	4	Washer-Belleville
27	3296-39	2	Nut-Lock, NI
28	323-4	6	Screw-HH
29	322-5	8	Screw-HH
30	3219-2	4	Nut-Hex
31	1-543017	6	Balljoint-RH
32	1-633152	2	Balljoint-LH
33	1-804524	2	Nut
34	1-603737	2	Bolt-Return, Neutral
35	100-7336	2	Washer
36	933156	2	Pin-Roll
37	302-11	2	Fitting-Lube, 45 DEG
38	104-3606	1	Linkage-Lower, RH
39	104-3607	1	Linkage-Lower, LH
40	104-3605	2	Linkage-Upper
41	32128-20	2	Nut-HF

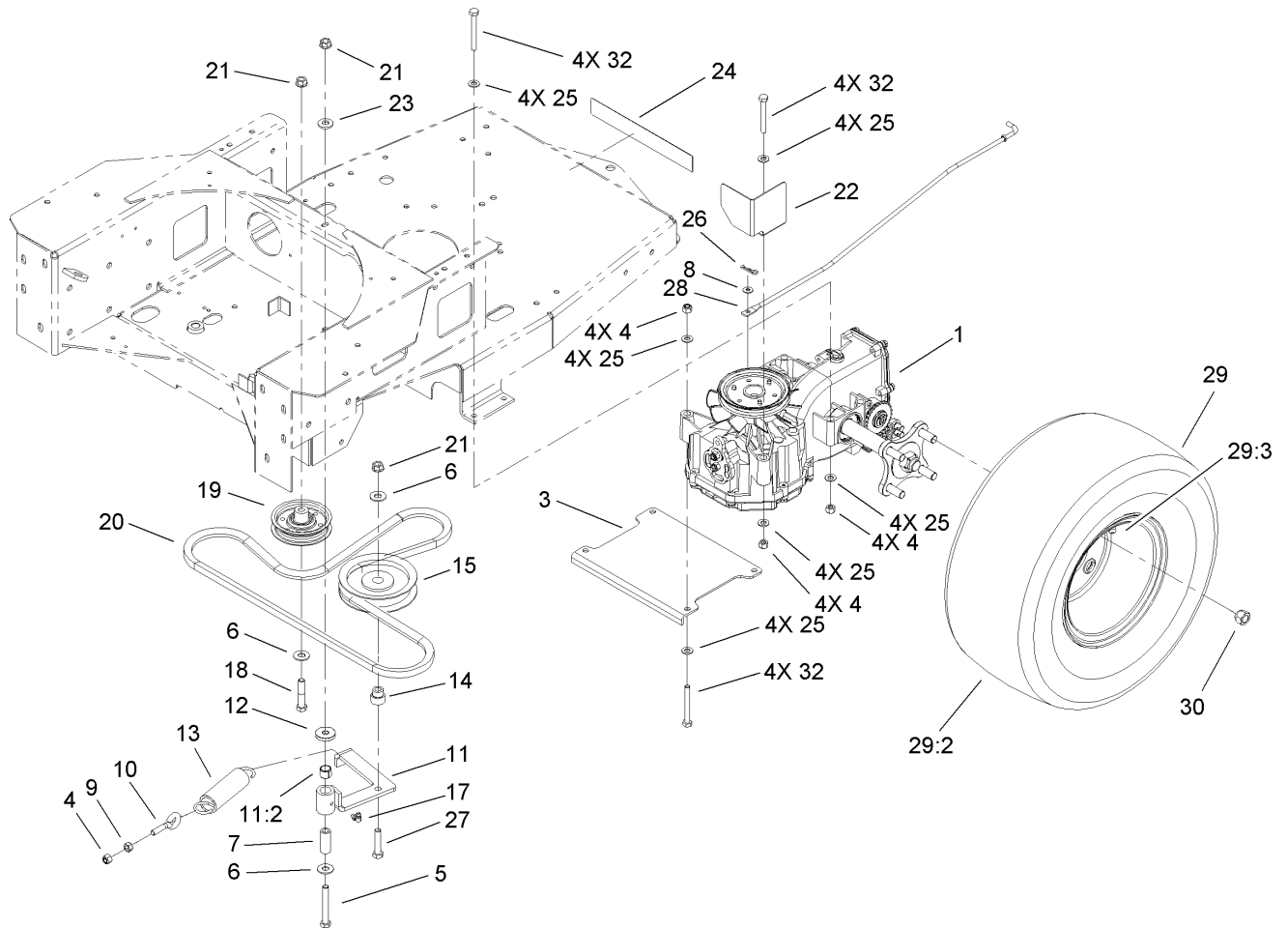

## Hydro and Belt Drive Assembly

Ref	Part No.	Qty.	Description
1	108-8507	1	Hydro-LH
❶2	108-8506	1	Hydro-RH
3	100-7317-03	1	Plate-Hydro, Lower
4	3296-29	13	Nut-Lock, NI
5	323-13	1	Screw-HH
6	3256-4	3	Washer-Flat
7	1-603044	1	Bushing
8	3256-1	2	Washer-Flat
9	32128-20	1	Nut-HF
10	55-9420	1	Bolt-Eye
11	104-3614	1	Idler Arm ASM
11:2	1-513034	2	Sleeve-Bearing
12	104-8005	1	Spacer
13	1-603414	1	Spring-Extension
14	1-603496	1	Bushing-Idler
15	1-603843	1	Pulley-Idler
❶16	104-3668	1	Rod-RH
17	302-40	1	Fitting-Grease
18	323-10	1	Screw-HH
19	104-3630	1	Pulley-Idler
20	104-3622	1	Belt-V
21	32128-21	3	Nut-HF
22	104-8033-03	1	Guard-Fan, LH
23	98-5975	1	Washer-Belleville

Ref	Part No.	Qty.	Description
24	104-8061	1	Decal
25	3256-23	24	Washer-Flat
26	1-806003	2	Pin-Hair
27	323-9	1	Screw-HH
28	104-3669	1	Rod-LH
29	107-2536	2	Wheel And Tire ASM
29:2	106-7006	1	Tire
29:3	232-27	1	Stem-Valve
❶29:99	107-2491	1	Tube-Tire
30	242-50	8	Nut-Lug
❶31	104-8013-03	1	Guard-Fan, RH
32	322-13	12	Screw-HH

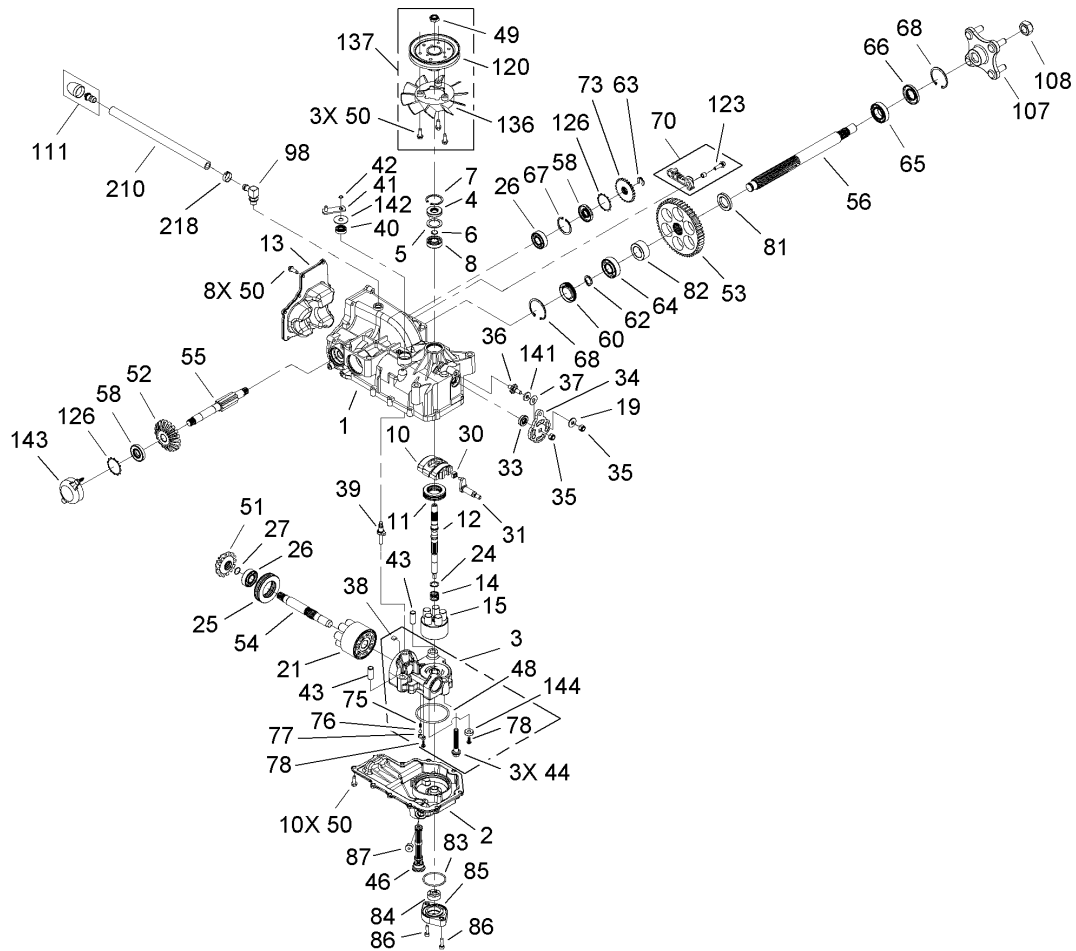

## LH Hydro Assembly No. 108-8507

Ref	Part No.	Qty.	Description
1	107-1700	1	Main Housing Kit
2	108-8541	1	Housing-Lower
3	108-8542	1	Center Section Kit
4	92-6543	1	Seal-Lip
5	104-2104	1	Spacer
6	94-1902	1	Ring-Wire, Retaining
7	94-1903	1	Ring-Retaining
8	94-1904	1	Bearing-Shaft, Ball
10	94-1907	1	Swashplate-Variable
11	94-6922	1	Bearing-Thrust
12	108-8543	1	Shaft-Input
13	105-1870	1	Cover-Back
14	94-1936	1	Spring-Block
15	104-2106	1	Cylinder Block ASM
19	5-4460	1	Washer-Pivot
21	94-1913	1	Cylinder Block ASM
24	94-1937	1	Washer-Block, Thrust
25	94-6923	1	Bearing-Thrust
26	104-5311	2	Bearing-Ball
27	104-5307	1	Ring-Retaining
30	94-1910	1	Guide-Slot
31	104-2112	1	Trunnion ASM
33	92-6544	1	Seal-Lip
34	105-1871	1	Arm-Control

Ref	Part No.	Qty.	Description
35	105-1872	2	Nut
36	104-2116	1	Stud
37	105-1873	1	Puck-Friction
38	94-6925	1	Plate-Bypass
39	94-1914	1	Actuator-Bypass
40	92-6545	1	Seal-Lip
41	104-2117	1	Arm-Bypass
42	936109	1	Ring-Retaining
43	94-1927	2	Pin
44	94-6926	3	Bolt
46	108-8544	1	Filter ASM
48	108-8545	1	O-Ring
49	105-1875	1	Nut-Lock
50	104-2120	21	Screw
51	105-1876	1	Gear-Bevel, 14T
52	105-1877	1	Gear-Bevel, 19T
53	105-1878	1	Gear-Bevel, 53T
54	105-1879	1	Shaft-Motor
55	105-1880	1	Shaft-Brake
56	105-1881	1	Shaft-Axle
58	104-5310	2	Seal-Lip
60	105-1882	1	Plug-Side Seal
62	105-1883	1	Ring-Axle, Retaining
63	105-1884	1	Ring-Retaining

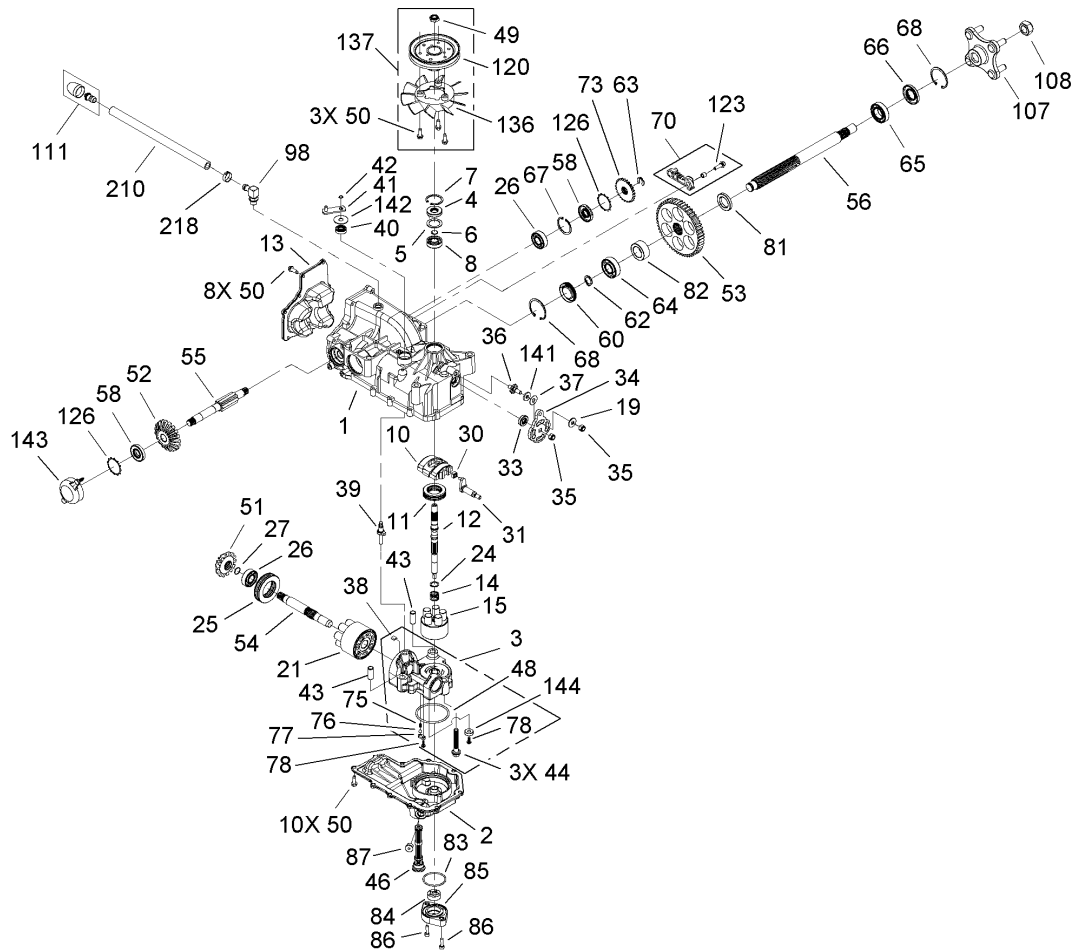

## LH Hydro Assembly No. 108-8507 (continued)

Ref	Part No.	Qty.	Description
64	105-1885	1	Bearing-Ball
65	105-1886	1	Bearing-Ball
66	105-1887	1	Seal
67	104-5309	1	Ring-Retaining
68	105-1888	2	Ring-Retaining, Axle
70	108-8547	1	RH Brake Arm ASM
73	105-1890	1	Disc-Brake
75	108-8548	1	Spring-Helical
76	108-8549	1	Ball-1/4In
77	108-8550	1	Plate-Relief
78	104-5352	2	Bolt-Tapping, Self
81	108-8552	1	Spacer
82	108-8553	1	Spacer
83	106-8757	1	O-Ring
84	104-2122	1	Gerotor ASM
85	104-2124	1	Cover-Gerotor
86	106-8758	2	Screw-HSH
87	104-2184	1	Spring-Arm, Brake
98	108-8559	1	Fitting-90 DEG
●100	104-2147	1	Sealant
107	105-1894	1	Hub ASM
108	105-1895	1	Nut
111	107-1701	1	Cap Vent ASM
120	104-1754	1	Pulley

Ref	Part No.	Qty.	Description
123	107-1703	1	Screw-HHF
126	105-1898	2	Ring-Retaining
●134	105-1899	1	Seal Kit
136	105-1927	1	Fan
137	105-1928	1	Fan Pulley Kit
141	107-1705	1	Washer
142	107-1706	1	Washer
143	107-1707	1	Cover-Brake, Plastic
144	104-5330	1	Magnet-Ring
210	108-8561	1	Hose
218	108-8562	1	Pinch-Clamp, Single Ear

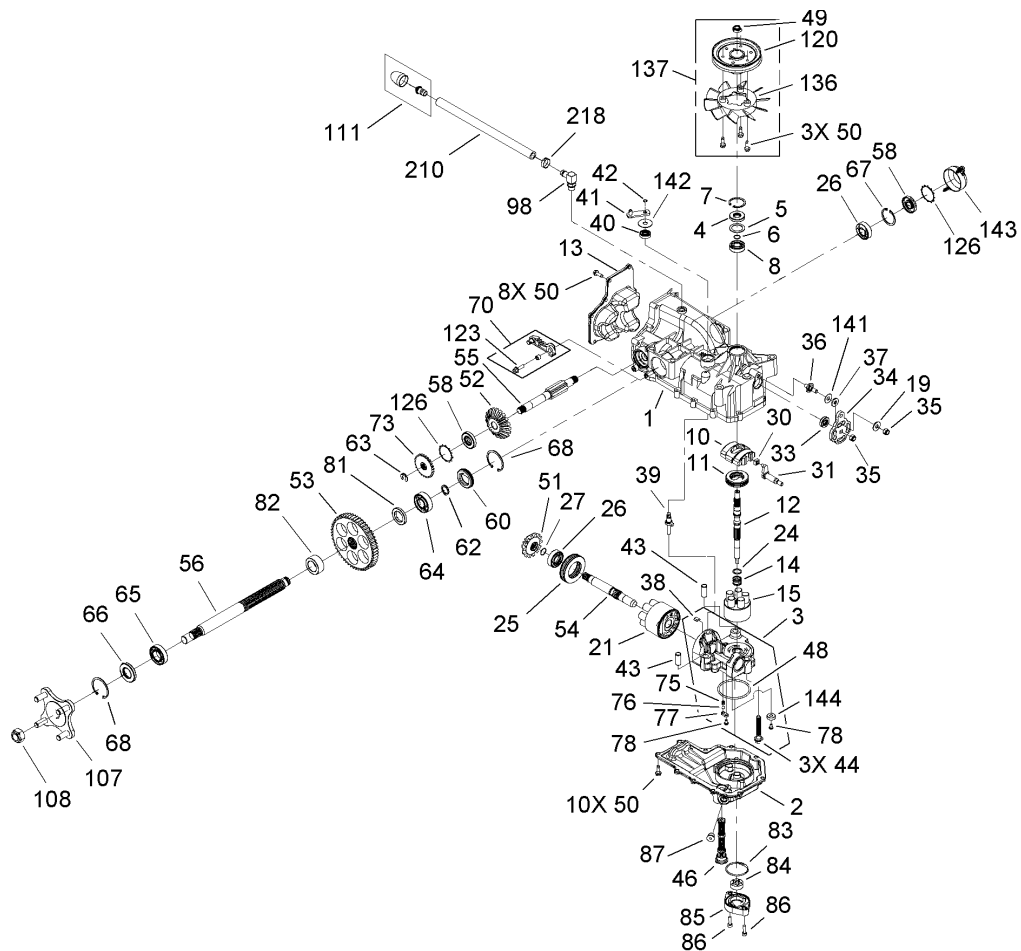

## RH Hydro Assembly No. 108-8506

Ref	Part No.	Qty.	Description
1	107-1700	1	Main Housing Kit
2	108-8541	1	Housing-Lower
3	108-8542	1	Center Section Kit
4	92-6543	1	Seal-Lip
5	104-2104	1	Spacer
6	94-1902	1	Ring-Wire, Retaining
7	94-1903	1	Ring-Retaining
8	94-1904	1	Bearing-Shaft, Ball
10	94-1907	1	Swashplate-Variable
11	94-6922	1	Bearing-Thrust
12	108-8543	1	Shaft-Input
13	105-1870	1	Cover-Back
14	94-1936	1	Spring-Block
15	104-2106	1	Cylinder Block ASM
19	5-4460	1	Washer-Pivot
21	94-1913	1	Cylinder Block ASM
24	94-1937	1	Washer-Block, Thrust
25	94-6923	1	Bearing-Thrust
26	104-5311	2	Bearing-Ball
27	104-5307	1	Ring-Retaining
30	94-1910	1	Guide-Slot
31	104-2112	1	Trunnion ASM
33	92-6544	1	Seal-Lip
34	105-1871	1	Arm-Control

Ref	Part No.	Qty.	Description
35	105-1872	2	Nut
36	104-2116	1	Stud
37	105-1873	1	Puck-Friction
38	94-6925	1	Plate-Bypass
39	94-1914	1	Actuator-Bypass
40	92-6545	1	Seal-Lip
41	104-2117	1	Arm-Bypass
42	936109	1	Ring-Retaining
43	94-1927	2	Pin
44	94-6926	3	Bolt
46	108-8544	1	Filter ASM
48	108-8545	1	O-Ring
49	105-1875	1	Nut-Lock
50	104-2120	21	Screw
51	105-1876	1	Gear-Bevel, 14T
52	105-1877	1	Gear-Bevel, 19T
53	105-1878	1	Gear-Bevel, 53T
54	105-1879	1	Shaft-Motor
55	105-1880	1	Shaft-Brake
56	105-1881	1	Shaft-Axle
58	104-5310	2	Seal-Lip
60	105-1882	1	Plug-Side Seal
62	105-1883	1	Ring-Axle, Retaining
63	105-1884	1	Ring-Retaining

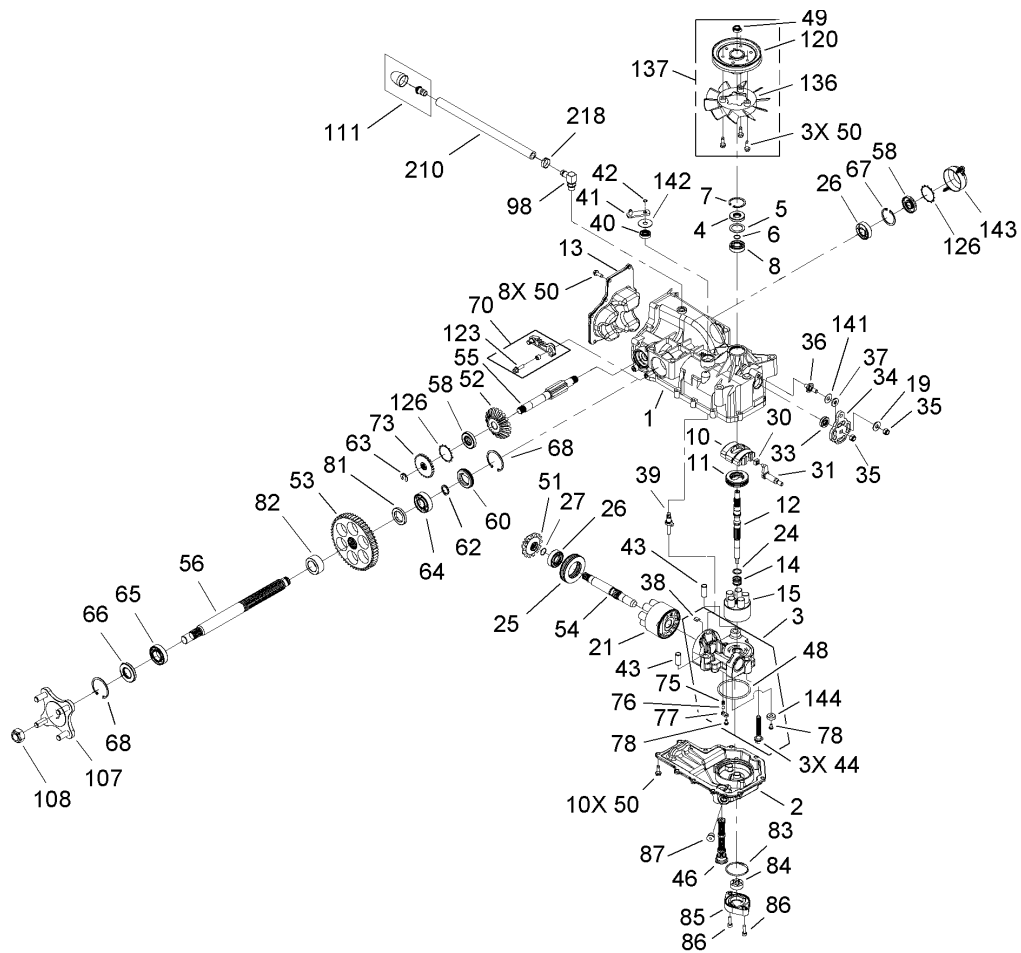

### RH Hydro Assembly No. 108-8506 (continued)

Ref	Part No.	Qty.	Description
64	105-1885	1	Bearing-Ball
65	105-1886	1	Bearing-Ball
66	105-1887	1	Seal
67	104-5309	1	Ring-Retaining
68	105-1888	2	Ring-Retaining, Axle
70	108-8546	1	LH Brake Arm ASM
73	105-1890	1	Disc-Brake
75	108-8548	1	Spring-Helical
76	108-8549	1	Ball-1/4In
77	108-8550	1	Plate-Relief
78	104-5352	2	Bolt-Tapping, Self
81	108-8552	1	Spacer
82	108-8553	1	Spacer
83	106-8757	1	O-Ring
84	104-2122	1	Gerotor ASM
85	104-2124	1	Cover-Gerotor
86	106-8758	2	Screw-HSH
87	104-2184	1	Spring-Arm, Brake
98	108-8559	1	Fitting-90 DEG
●100	104-2147	1	Sealant
107	105-1894	1	Hub ASM
108	105-1895	1	Nut
111	107-1701	1	Cap Vent ASM
120	105-1896	1	Pulley

Ref	Part No.	Qty.	Description
123	107-1703	1	Screw-HHF
126	105-1898	2	Ring-Retaining
●134	105-1899	1	Seal Kit
136	105-1927	1	Fan
137	105-1928	1	Fan Pulley Kit
141	107-1705	1	Washer
142	107-1706	1	Washer
143	107-1707	1	Cover-Brake, Plastic
144	104-5330	1	Magnet-Ring
210	108-8561	1	Hose
218	108-8562	1	Pinch-Clamp, Single Ear

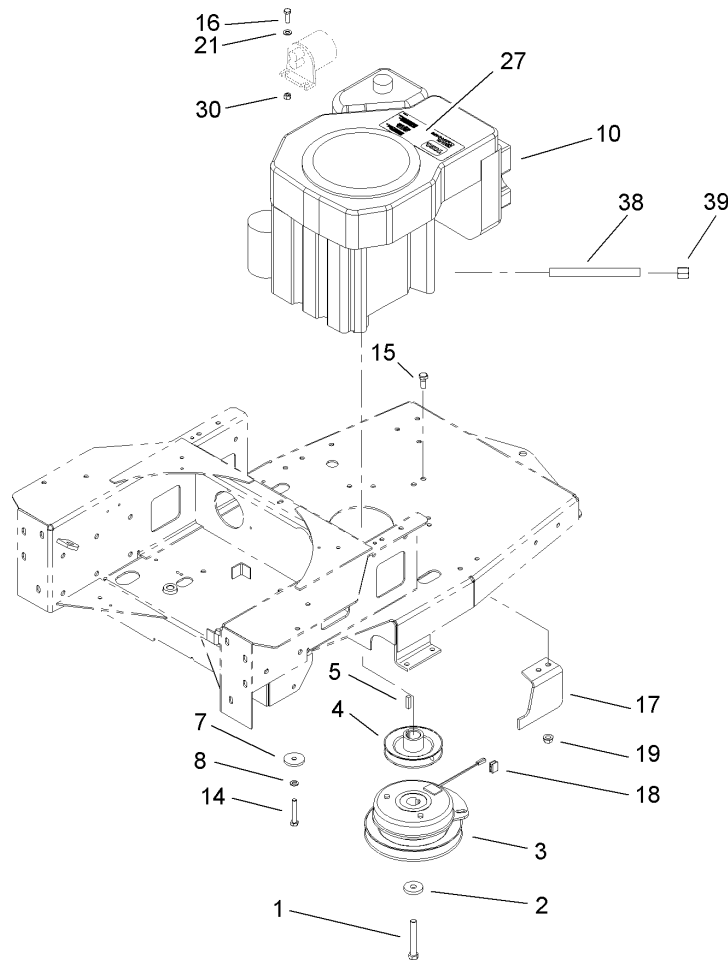

## Engine and Clutch Assembly

Ref	Part No.	Qty.	Description				
1	3212-12	1	Screw-HH				
2	112843	1	Washer				
3	108-9512	1	Clutch-PTO, Electric				
4	100-7314	1	Pump Drive Pulley ASM				
5	5-7280	1	Key				
7	62-7190	4	Spacer-Steel				
8	3253-4	4	Washer-Lock				
10		1	Engine-Kohler, Cv492S-27525				
14	33114-030	4	Screw-HH				
15	323-4	2	Screw-HH				
16	322-5	2	Screw-HH				
17	104-3613-03	1	Stop-Clutch				
18	98-5023	1	Bumper				
19	32128-21	2	Nut-HF				
21	3256-23	2	Washer-Flat				
27	110-6535	1	Decal				
30	3296-29	2	Nut-Lock, NI				
38	104-8018	1	Nipple-Pipe				
39	288-10	1	Cap-Pipe				

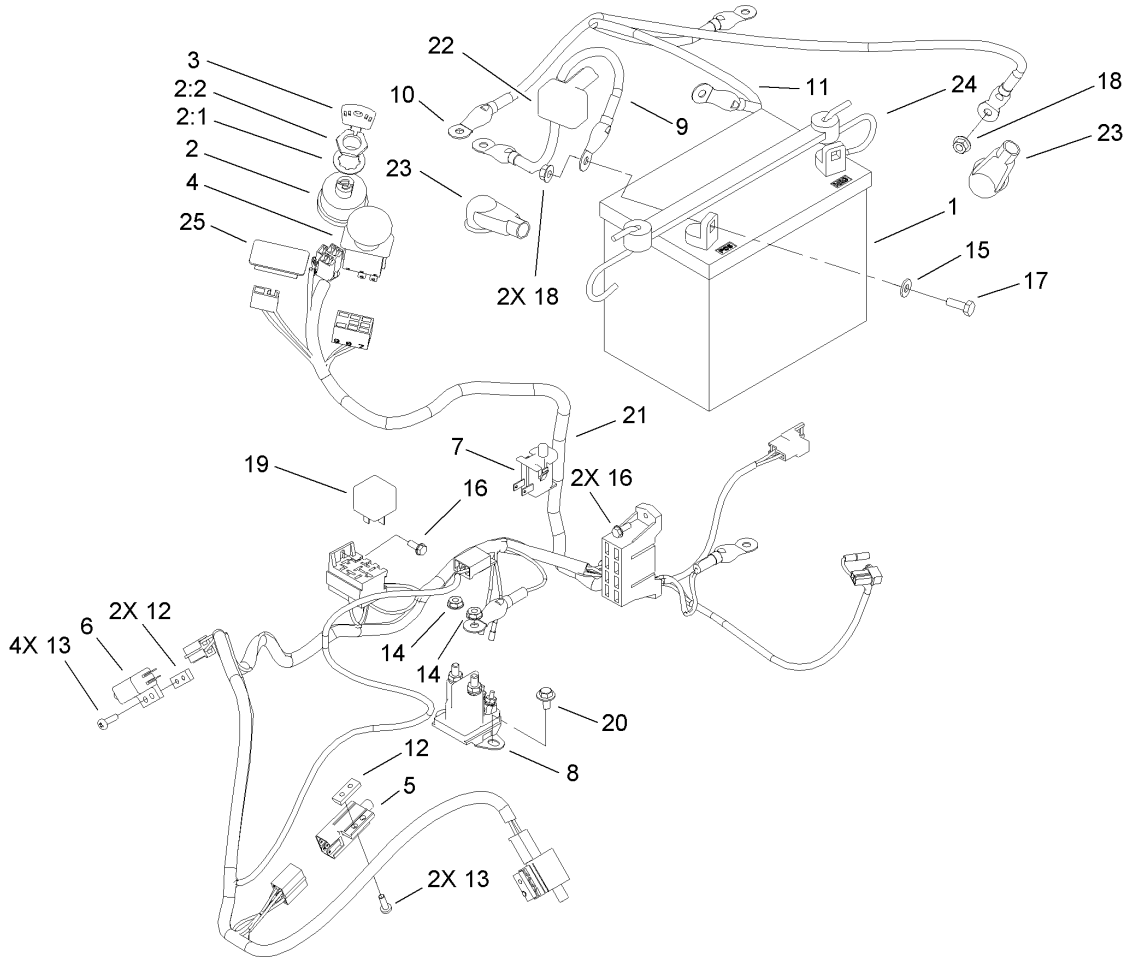

## Electrical Assembly

Ref	Part No.	Qty.	Description
1	104-2491	1	Battery-Dry
2	88-9830	1	Key Switch ASM
2:1	3254-5	1	Washer-Tooth
2:2	218-461	1	Nut-HH
3	63-8360	1	Key-Ignition
4	95-7489	1	Switch-PTO
5	86-4690	1	Switch-Interlock
6	65-7410	2	Switch-Pole, Single
7	82-2190	1	Switch-Bail
8	106-8245	1	Solenoid
9	56-7670	1	Wire ASM
10	54-2030	1	Wire ASM
11	93-0324	1	Cable
12	1-633181	3	Plate-Tapped
13	32144-8	6	Screw-PPHTF
14	32149-2	2	Nut-Keps
15	3256-22	2	Washer-Flat
16	32144-1	3	Screw-Taptite
17	321-4	2	Screw-HH
18	32128-33	3	Nut-HF
19	98-7249	1	Relay
20	46-8560	2	Screw-HHF
21	110-6517	1	Harness-Wire
22	28-8080	1	Boot-Terminal

Ref	Part No.	Qty.	Description
23	93-3190	2	Boot-Insulator, Terminal
24	104-2466	1	Holddown-Battery
25	99-7420	1	Plug-Hole

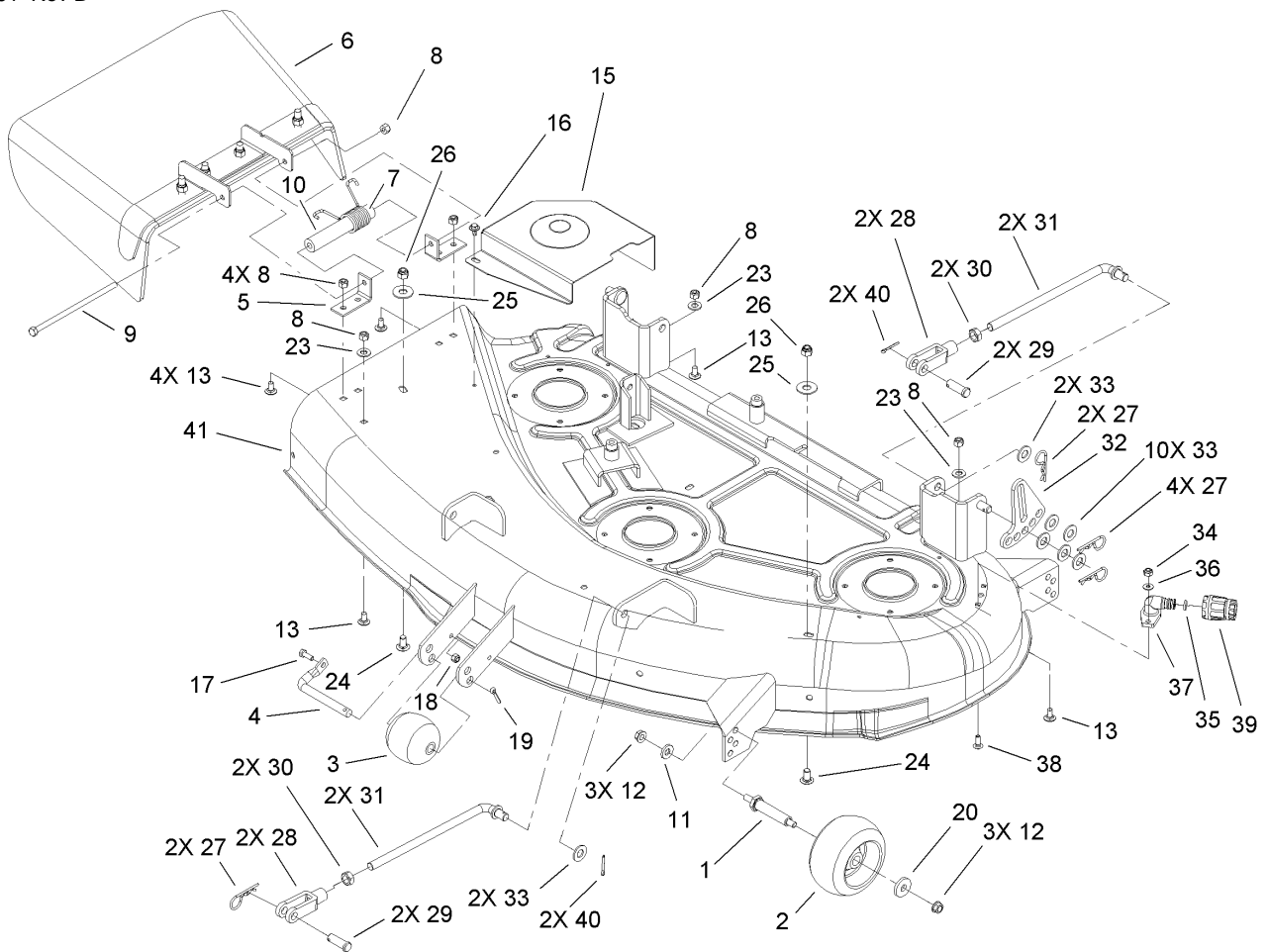

## 44 Inch Deck Assembly

Ref	Part No.	Qty.	Description
1	99-2842	3	Spacer
2	1-603299	3	Roller-Scalp, Anti
3	29-4820	1	Roller
4	118960-03	1	Shaft-Roller
5	108-6196-03	2	Bracket-Pivot, Deflector
6	108-8591	1	Deflector ASM
7	108-4052	1	Spring-Torsion
8	3296-29	8	Nut-Lock, NI
9	108-8539	1	Bolt-HH
10	108-7159	1	Spacer-Deflector
11	98-5975	3	Washer-Belleville
12	3290-357	6	Nut-HHF, Whiz
13	3230-18	7	Screw-CARR
14	110-1877-03	1	Cover-Belt, LH
15	110-1878-03	1	Cover-Belt, RH
16	46-8560	4	Screw-HHF
17	321-4	1	Screw-HH
18	3296-42	1	Nut-Lock, NI
19	3272-21	1	Pin-Cotter
20	1-373034	3	Washer
23	3256-24	3	Washer-Flat
24	3231-21	2	Screw-CARR
25	3256-5	2	Washer-Flat
26	3296-39	2	Nut-Lock, NI

Ref	Part No.	Qty.	Description
27	1-806005	8	Pin-Hair
28	100-7338	4	Clevis
29	104-3634	4	Pin-Clevis
30	3220-5	4	Nut-Jam
31	104-8047	4	Rod-Trunion
32	104-3699-01	2	Link-HOC, Adjusting
33	3256-26	14	Washer-Flat
34	3296-16	2	Nut-Lock, NI
35	46-6290	1	O-Ring
36	3256-1	2	Washer-Flat
37	95-2747	1	Fitting-Washout
38	3229-1	2	Screw-CARR
39	95-3270	1	Connector-Hose
40	3272-10	4	Pin-Cotter
41	105-1948	1	44 Inch Deck ASM



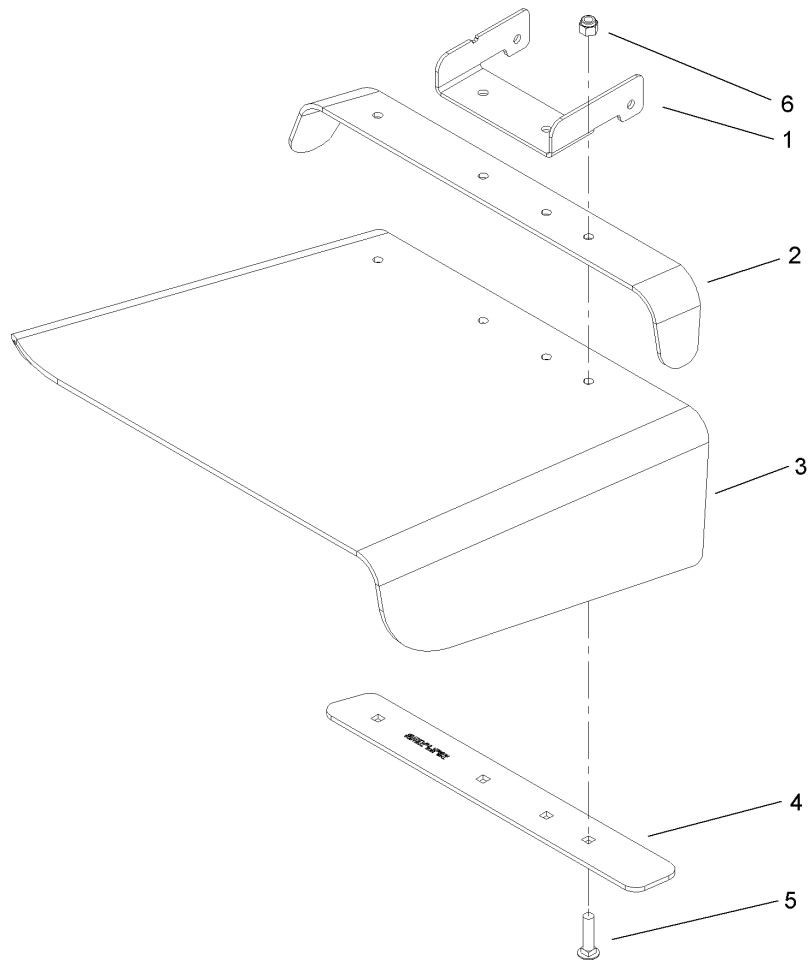

### Deflector Assembly No. 108-8591

Ref	Part No.	Qty.	Description
1	108-6184-03	1	Hinge-Deflector
2	108-6172-03	1	Support-Discharge
3	108-8590	1	Deflector-Rubber
4	108-6174-03	1	Strap-Discharge
5	3230-3	4	Screw-CARR
6	3296-29	4	Nut-Lock, NI

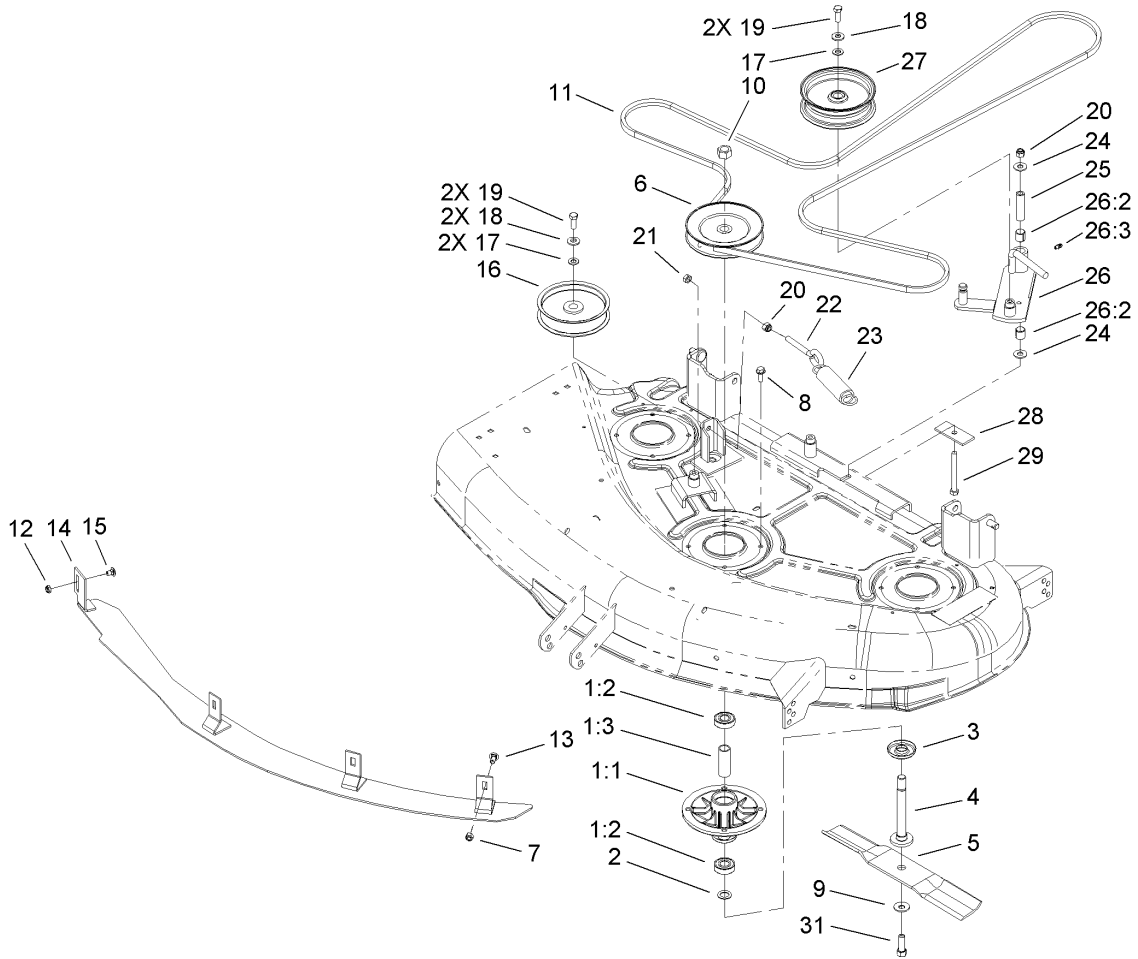

## 44in Deck Belt Drive Assembly

Ref	Part No.	Qty.	Description
<b>1</b>	<b>21</b>	3	Spindle ASM
1:1	88-4510	1	Housing-Spindle
1:2	100-1048	2	Bearing-Ball
1:3	62-3661	1	Spacer-Bearing
2	80-4380	3	Spacer
3	80-4360	3	Shield-Bearing
4	80-4341	3	Shaft
5	54-0010-03	3	Blade
6	100-7321	3	Pulley ASM
7	3296-29	3	Nut-Lock, NI
8	32144-41	12	Screw-Taptite
9	3290-465	3	Washer-Belleville
10	3219-6	3	Nut-Hex
11	105-6963	1	Belt-V
12	3296-47	1	Nut-Lock, NI
13	3230-1	3	Bolt-CARR
14	93-9950-03	1	Baffle
15	3230-19	1	Screw-CARR
16	1-613098	2	Pulley-Idler
17	3256-24	3	Washer-Flat
18	98-5975	3	Washer-Belleville
19	323-6	3	Screw-HH
20	3296-39	2	Nut-Lock, NI
21	3217-7	1	Nut-Hex

Ref	Part No.	Qty.	Description
22	94-2547	1	Bolt-Eye
23	105-6992	1	Spring-Extension
24	1-809107	2	Washer-Hardened
25	1-603384	1	Bushing-Pivot, Idler
26	105-7010	1	Idler Arm ASM
26:2	1-513034	2	Sleeve-Bearing
26:3	302-5	1	Fitting-Grease
27	99-8912	1	Pulley-Idler, Flat
28	1-800805	1	Screw-HH
29	104-8037-03	1	Plate-Bolt, Retainer
31	26-0671	3	Screw-Blade



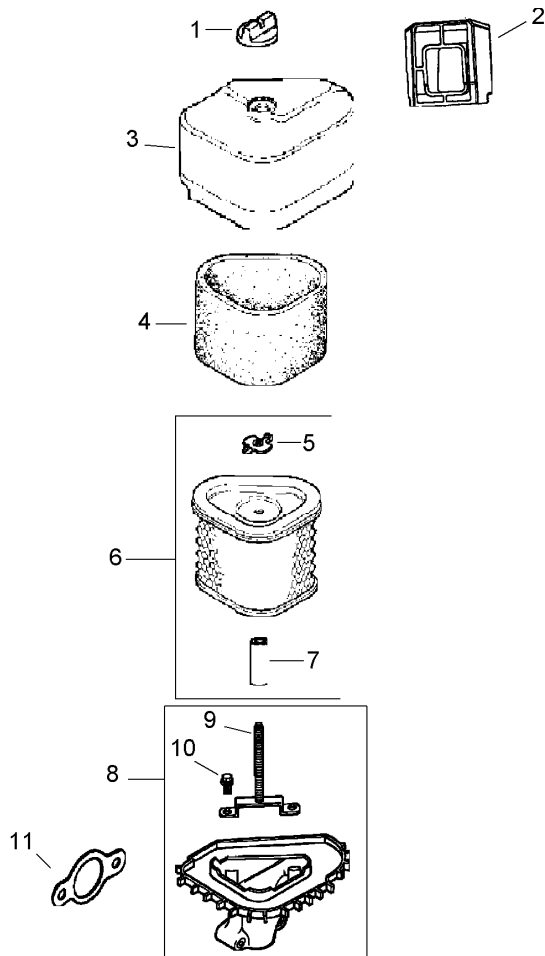

## Air Intake and Filtration Assembly Kohler Cv492s-27525

Ref	Part No.	Qty.	Description				
❶	25 341 03-S	1	Knob-Cover				
❷	12 281 02-S	1	Duct-Air				
❸	12 096 44-S	1	Cover-Cleaner, Air				
❹	12 083 12-S	1	Element-Precleaner				
❺	12 100 01-S	1	Nut-Wing				
❻	12 083 10-S	1	Element, Air Cleaner (Includes 5, 7, 8)				
❼	12 032 11-S	1	Seal				
❽	12 094 14-S	1	Base, Air Cleaner (Includes 10, 11)				
❾	12 072 04-S	1	Stud				
❿	12 086 01-S	2	Screw				
⓫	12 041 02-S	1	Gasket-Base, Air Cleaner				
⓬	12 113 04-S	1	Decal-Cleaner, Air				

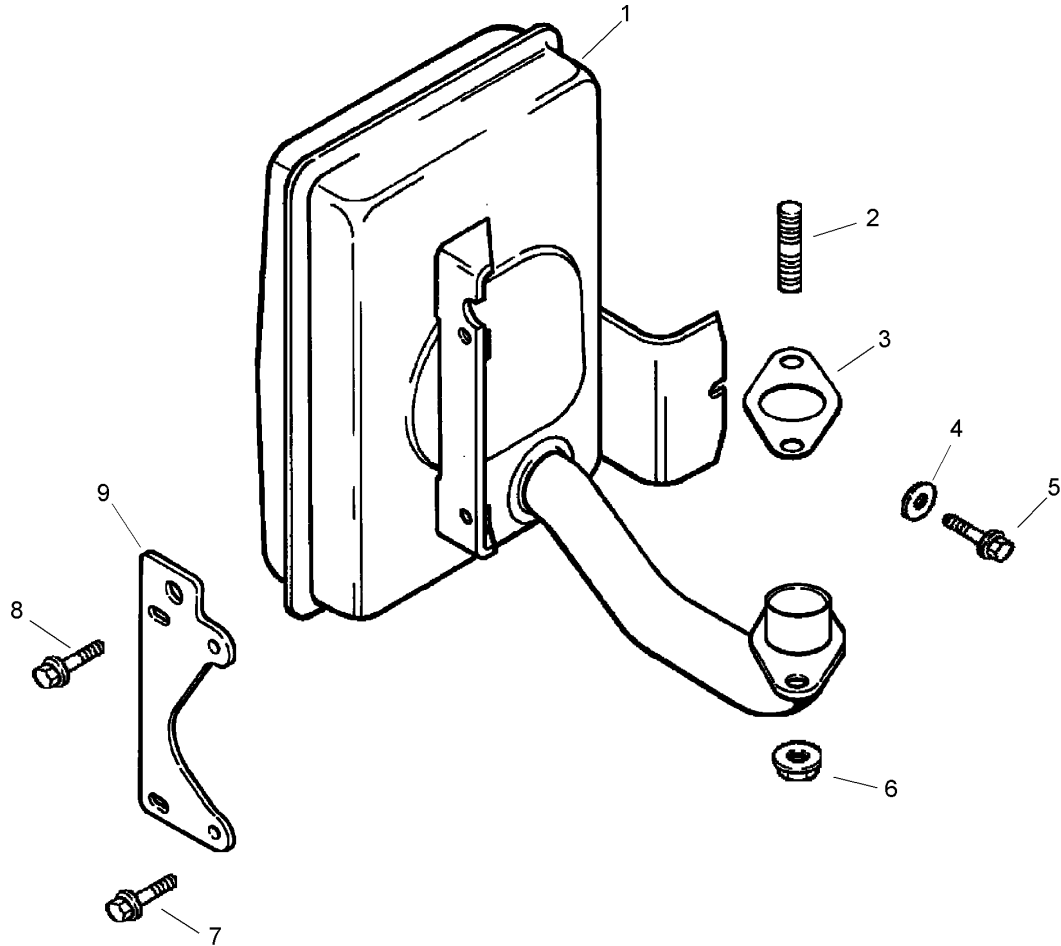

## Exhaust Assembly Kohler Cv492s-27525

Ref	Part No.	Qty.	Description				
❶	12 068 55-S	1	Muffler				
❷	25 072 04-S	2	Stud (M8X1.25X33)				
❸	12 041 03-S	1	Gasket-Manifold, Exhaust				
❹	X-25-78-S	1	Washer-Plain (1/4In)				
❺	M-545016-S	1	Screw-HHFTF (M5X0.8X16)				
❻	M-841080-S	2	Nut-Hex, Flange (M8X1.25)				
❼	M-645016-S	2	Screw-HHFTF (M6X1.0X16)				
❽	M-645025-S	2	Screw-HF (M6X1.0X25)				
❾	12 126 71-S	1	Bracket-Muffler				
❿	12 755 70-S	1	Kit, Muffler Guard (Includes Screw (4) M-545010-S)				
⓫	M-545010-S	4	Screw-HHFTF (M5X0.8X10)				
⓬	12112 20-S	2	Spacer				
⓭	12 522 511	1	Short Block				
⓮	12 755 93-S	1	Gasket Set				

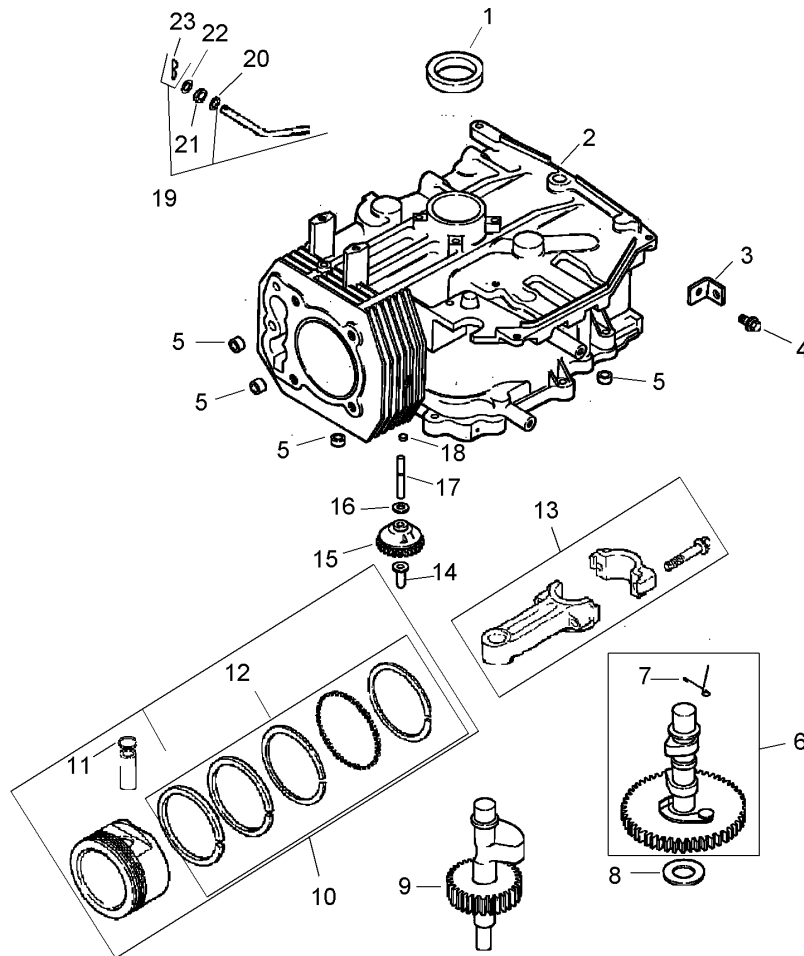

## Crankcase Assembly Kohler Cv492s-27525

Ref	Part No.	Qty.	Description
1	12 032 03-S	1	Seal-Oil
2		1	Crankcase (Use: Short Block 12 522 69)
3	12 445 02-S	1	Strap-Lifting
4	M-839025-S	1	Screw-HF (M8X1.25X25)
5	24 380 13-S	4	Pin-Locating
6	12 010 31-S	1	Camshaft (Includes 7)
7	12 089 31-S	1	Spring-Actuating
8	12 422 08-S	1	Shim-Camshaft (Blue .03)
9	12 422 09-S	1	Shim-Camshaft (Red .032)
10	12 422 10-S	1	Shim-Camshaft (Yellow .034)
11	12 422 11-S	1	Shim-Camshaft (Green .036)
12	12 422 12-S	1	Shim-Camshaft (Gray .038)
13	12 422 13-S	1	Shim-Camshaft (Black .04)
14	12 422 07-S	1	Shim-Camshaft (White .028)
15	12 144 28-S	1	Shaft-Balance
16	12 874 07-S	1	Piston W/Ring Set (STD.) (Includes 11, 12)
17	12 874 11-S	1	Piston W/Ring Set (.08)
18	12 874 08-S	1	Piston W/Ring Set (.25)
19	12 874 09-S	1	Piston W/Ring Set (.50)
20	12 018 02-S	2	Retainer-Pin, Piston
21	12 108 07-S	1	Ring Set (STD. And .08)
22	12 108 08-S	1	Ring Set (.25)

Ref	Part No.	Qty.	Description
23	12 108 09-S	1	Ring Set (.50)
24	12 067 11-S	1	Rod-Connecting (STD)
25	12 067 12-S	1	Rod-Connecting (.25)
26	12 380 01-S	1	Pin-Regulating, Governor
27	12 043 05-S	1	Gear-Governor
28	M-631005-S	1	Washer-Plain (6 Mm)
29	12 144 02-S	1	Shaft-Gear, Governor
30	52 139 09-S	1	Plug-Cup
31	12 755 64-S	1	Kit, Governor Cross Shaft W/Clip (Includes 23)
32	X-25-102-S	1	Washer-Flat (1/4)
33	12 032 01-S	1	Seal-Cross Shaft, Governor
34	M-631015-S	1	Washer-Flat (6Mm)
35	12 154 05-S	1	Clip-Pin, Hitch

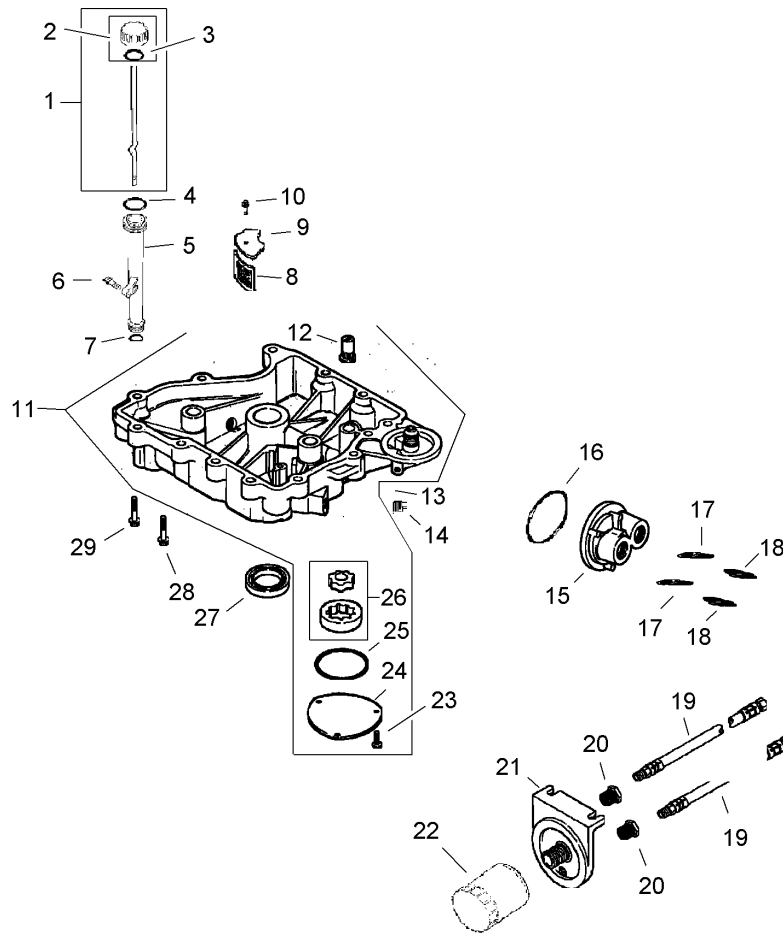

## Oil Pan and Lubrication Assembly Kohler Cv492s-27525

Ref	Part No.	Qty.	Description
❶	12 038 01-S	1	Dipstick (Includes 2, 3)
❷	25 755 13-S	1	Kit, Oil Fill Cap (Includes 3)
❸	25 153 02-S	1	O-Ring
❹	12 153 02-S	1	O-Ring
❺	12 123 04-S	1	Oil Fill Tube ASM
❻	M-545020-S	1	Screw-HHFTF (M5X0.8X20)
❼	12 153 01-S	1	O-Ring
❽	25 162 07-S	1	Screen-Pickup, Oil
❾	12 096 03-S	1	Cover-Screen, Oil Pickup
❿	M-545016-S	1	Screw-HHFTF (M5X0.8X16)
⓫	12 199 50-S	1	Pan Assembly, Oil (Includes 12, 23-26)
⓬	25 462 09-S	1	Valve-Relief, Oil Pressure
⓭	25 139 52-S	1	Plug-Pipe (1/8In)
⓮	25 139 57-S	2	Plug-Solid, Square Head (.38)
⓯	12 029 02-S	1	Adapter, Oil Filter
⓰	24 153 13-S	1	O-Ring
⓱	25 158 10-S	2	Bushing, Reducing 7/8X1/4X1/2 N.P.T.F.
⓲	52 136 02-S	2	Nipple-Metallic
⓳	52 326 11-S	2	Hose, Oil (Red Tracer) (2) 1/8-27 N.P.T.F. Male Coupling, 1/4-18 N.P.S.M. Female Coupling X 23In Long

Ref	Part No.	Qty.	Description
⓴	25 158 15-S	2	Bushing, Reducing 1/8X1/4 N.P.T.F.
⓵	12 029 02-S	1	Adapter, Oil Filter
⓶	12 050 01-S	1	Filter-Oil
⓷	M-545016-S	3	Screw-HHFTF (M5X0.8X16)
⓸	12 096 34-S	1	Cover-Pump, Oil
⓹	12 153 06-S	1	O-Ring (Oil Pump Cover)
⓺	12 393 01-S	1	Oil Pump ASM
⓻	12 032 03-S	1	Seal-Oil
⓼	24 086 16-S	11	Screw-HF (M8X1.25X45)
⓽	24 086 17-S	1	Screw-HF (M8X1.25X45)

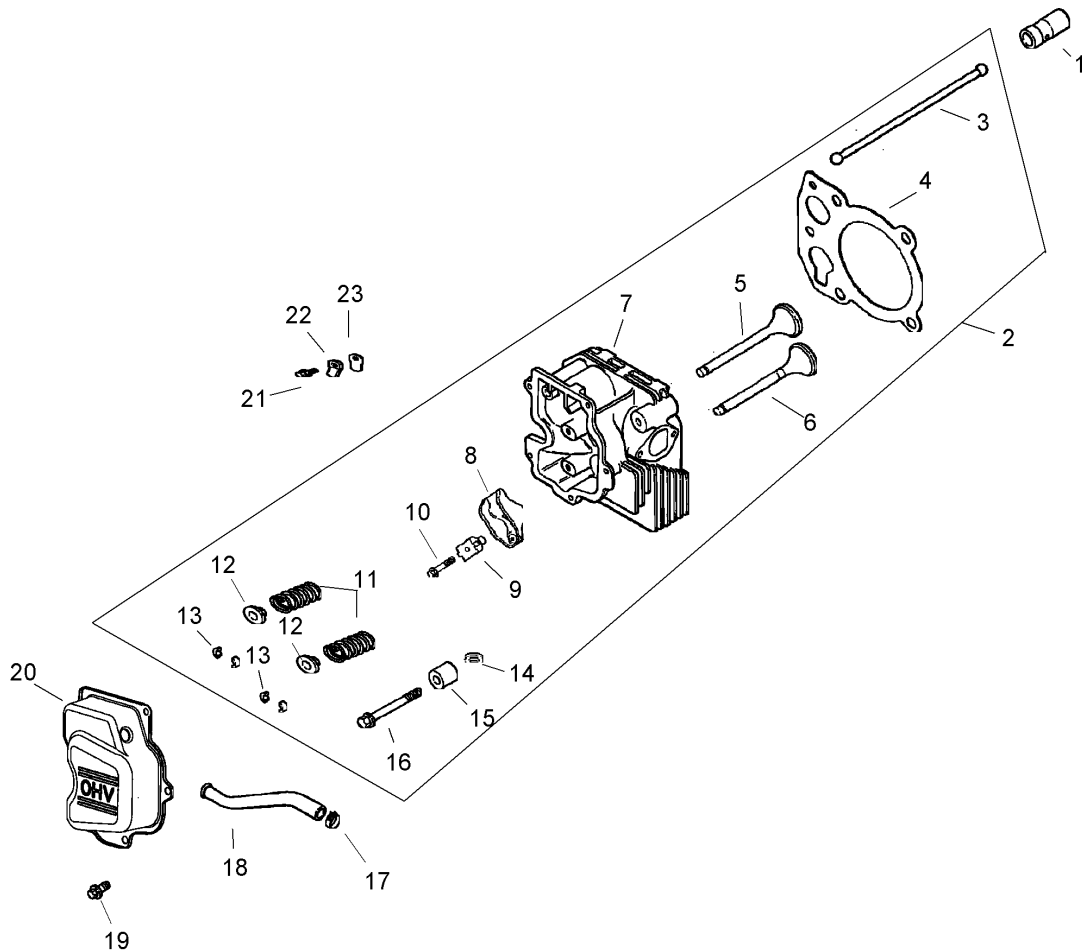

## Head, Valve and Breather Assembly Kohler Cv492s-27525

Ref	Part No.	Qty.	Description
❶	25 351 01-S	2	Lifter-Valve
❷	24 755 101-S	1	Kit, Cylinder Head (Includes 3-16, Carburetor Gasket (2),
❸	12 411 05-S	2	Rod-Push
❹	12 041 10-S	1	Gasket-Head, Cylinder
❺	12 017 01-S	1	Valve-Intake (STD)
❻	12 016 01-S	1	Valve-Exhaust (STD)
❼	12 318 51-S	1	Head-Cylinder
❽	25 186 01-S	2	Arm-Rocker
❾	12 599 03-S	2	Pivot-Arm, Rocker
❿	M-640034-S	2	Screw-HF (M6X1.0X34)
⓫	12 089 34-S	2	Spring-Valve
⓬	12 173 01-S	2	Cap-Spring, Valve
⓭	12 755 03-S	2	Retainer Kit
⓮	12 468 05-S	1	Washer-Flat (1/2)
⓯	12 112 13-S	1	Spacer-Head Bolt (Exhaust Port)
⓰	20 086 02-S	5	Screw-Flange, Hex (M10X1.5X37)
⓱	25 237 14-S	1	Clamp-Hose
⓲	12 326 18-S	1	Hose-Breather
⓳	M-645016-S	5	Screw-HHFTF (M6X1.0X16)
⓴	12 096 47-S	1	Cover-Valve
⓵	M-545010-S	1	Screw-HHFTF (M5X0.8X10)
⓶	66 018 04-S	1	Retainer-Reed, Breather
⓷	12 402 02-S	1	Reed-Breather

Ref	Part No.	Qty.	Description
❶❶	12 017 02-S	1	Valve-Intake (.25)
❶❷	12 016 02-S	1	Valve-Exhaust (.25)
❶❸	12 041 01-S	2	Gasket-Carburetor
❶❹	12 041 02-S	1	Gasket-Base, Air Cleaner
❶❺	12 041 03-S	1	Gasket-Manifold, Exhaust

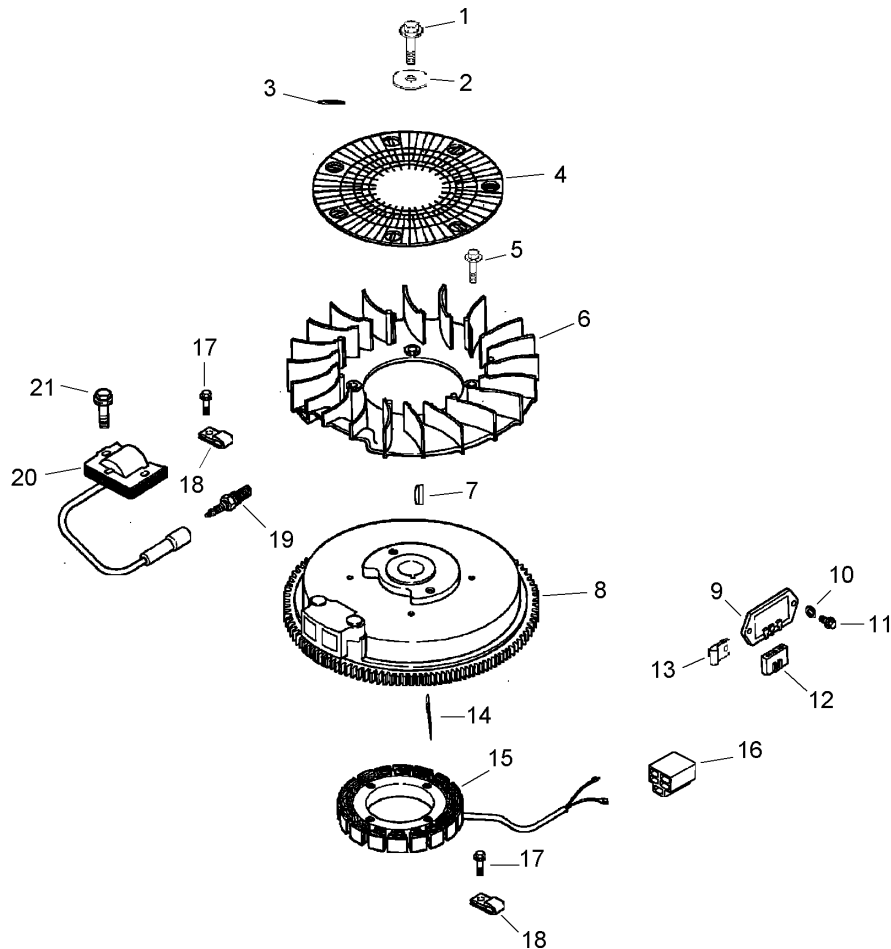

## Ignition and Electrical Assembly Kohler Cv492s-27525

Ref	Part No.	Qty.	Description
❶	12 086 14-S	1	Screw-Hex, Flange (M10X1.5X45)
❷	12 468 03-S	1	Washer-Flat (.38)
❸	24 018 03-S	3	Retainer
❹	24 162 03-S	1	Screen-Grass
❺	25 086 47-S	4	Bolt-Shoulder (M6X1.0X16)
❻	12 157 06-S	1	Fan
❼	X-42-15-S	1	Key (.19 X .62)
❽	12 025 15-S	1	Flywheel
❾	41 403 09-S	1	Rectifier-Regulator
❿	X-22-11-S	1	Washer-Lock, Internal Tooth (1/4)
⓫	12 086 42-S	2	Screw-HF (M6X1.0X16)
⓬	236602-S	1	Connector (3 Contact)
⓭	12 157 07-S	2	Clip, Rectifier-Regulator
⓮	M-548025-S	2	Screw-HHFTF (M5X0.8X25)
⓯	237878-S	1	Kit, Stator (Includes Terminal 25 452 01-S)
⓰	48 155 01-S	1	Connector (5 Contact)
⓱	M-545010-S	2	Screw-HHFTF (M5X0.8X10)
⓲	X-728-1-S	2	Clip
⓳	12 132 02-S	1	Spark Plug
⓴	12 584 04-S	1	Module-Ignition
⓵	M-545020-S	2	Screw-HHFTF (M5X0.8X20)

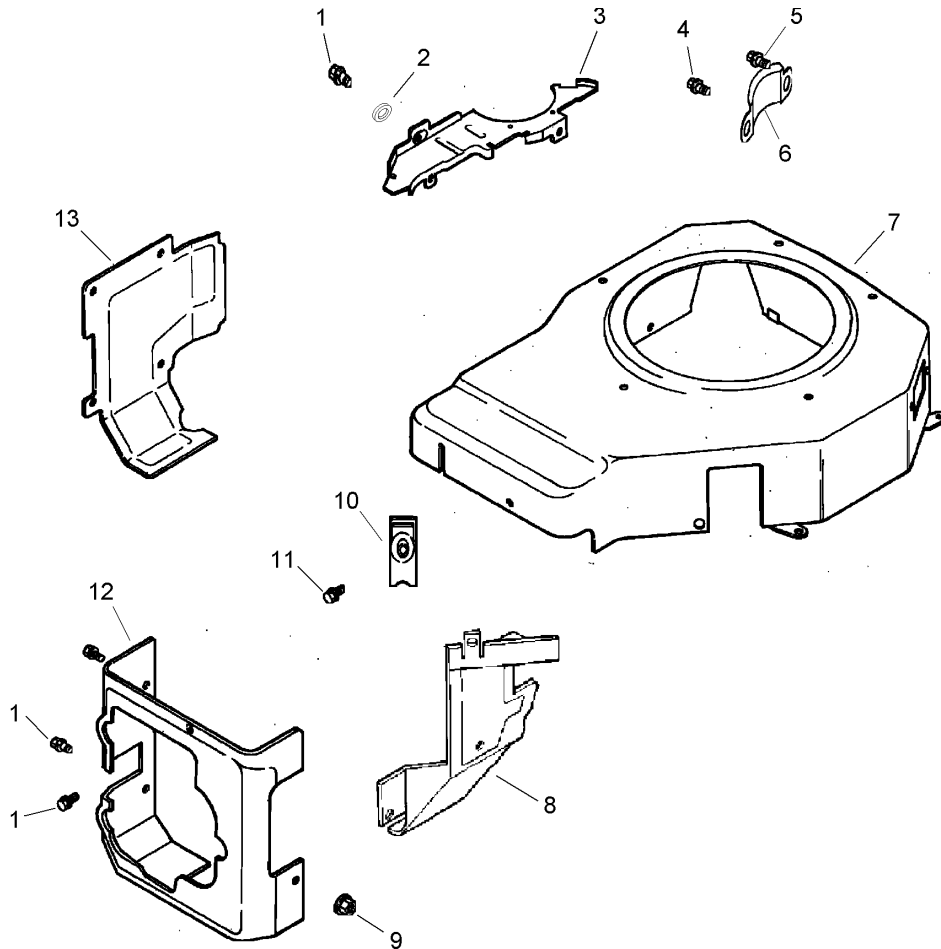
## Blower Housing and Baffle Assembly Kohler Cv492s-27525

Ref	Part No.	Qty.	Description				
1	M-545010-S	5	Screw-HHFTF (M5X0.8X10)				
2	24 468 10-S	1	Washer-Plain (1/4)				
3	12 146 07-S	1	Plate-Housing, Blower				
4	M-645016-S	1	Screw-HHFTF (M6X1.0X16)				
5	M-550010-S	1	Screw-HF (M5X0.8X10)				
6	24 096 05-S	1	Cover-Pinion				
7	12 027 55-S	1	Housing-Blower				
8	12 063 18-S	1	Baffle (Intake Side)				
9	M-541050-S	1	Nut-HF (M5X0.8)				
10	25 154 02-S	3	Clip-Mounting				
11	12 086 37-S	3	Screw-Washer, Captive (M5X0.8X20)				
12	12 063 20-S	1	Baffle (Cylinder Head)				
13	12 063 19-S	1	Baffle-Cylinder				
13	12 113 119-S	1	Decal, 18 Hp				

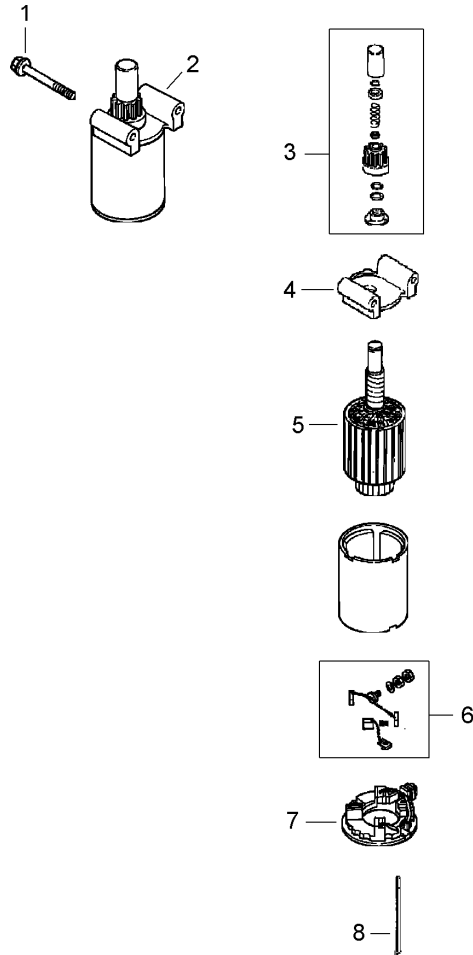

## Starter Assembly Kohler Cv492s-27525

Ref	Part No.	Qty.	Description
1	M-839070-S	2	Screw-HF (M8X1.25X70)
2	12 098 22-S	1	Starter Assembly (Includes 3-8)
3	12 755 53-S	1	Drive Kit
4	12 227 19-S	1	Cap-End, Drive
5	12 170 05-S	1	Armature
6	12 221 01-S	1	Brush ASM
7	12 227 13-S	1	Commutator-Cap, End
8	12 211 01-S	2	Bolt

--	--	--	--

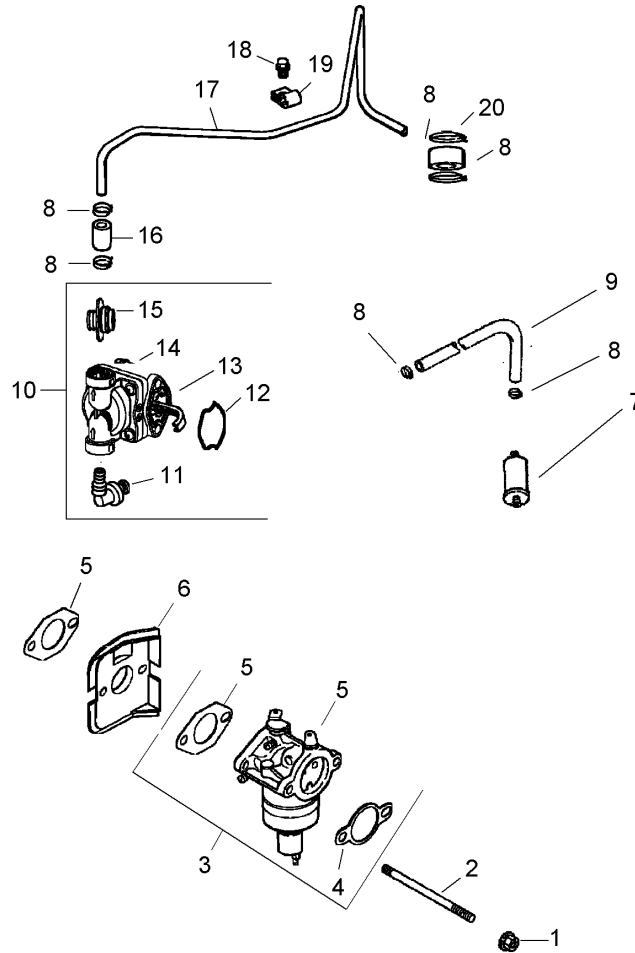

## Fuel System Assembly Kohler Cv492s-27525

Ref	Part No.	Qty.	Description				
❶	M-641060-S	2	Nut-Hex, Flange (M6X1.0)				
❷	M-629116-S	2	Stud (M6X1.0X116)				
❸	12 853 117-S	1	Carburetor Kit (Includes 4, 5 [qty. 1], Tie 12 454 03-S, And Terminal 25 452 20-S)				
❹	12 041 02-S	1	Gasket-Base, Air Cleaner				
❺	12 041 01-S	2	Gasket-Carburetor				
❻	12 265 06-S	1	Deflector-Heat				
❼	12 294 13-S	1	Fitting-90 DEG				
❽	25 237 14-S	6	Clamp-Hose				
❾	25 353 14-S	1	Line-Fuel, 7 Inch				
❿	25 050 07-S	1	Filter-Fuel				
⓫	12 559 02-S	1	Kit, Fuel Pump (Includes 13-15)				
⓬	M-645020-S	2	Screw-Flange, Hex (M6X1.0X20)				
⓭	25 041 10-S	2	Gasket, Fuel Pump				
⓮	25 153 04-S	1	O-Ring (Fuel Pump)				
⓯	25 294 09-S	1	Connector-Hose, Straight				
⓰	12 353 01-S	1	Line-Fuel (1-1/4In)				
⓱	12 123 19-S	1	Line-Fuel. Metal				
⓲	M-545010-S	1	Screw-HHFTF (M5X0.8X10)				
⓳	12 154 01-S	1	Clamp-Line, Fuel				
⓴	41 353 18-S	1	Line-Fuel (2-1/2In)				

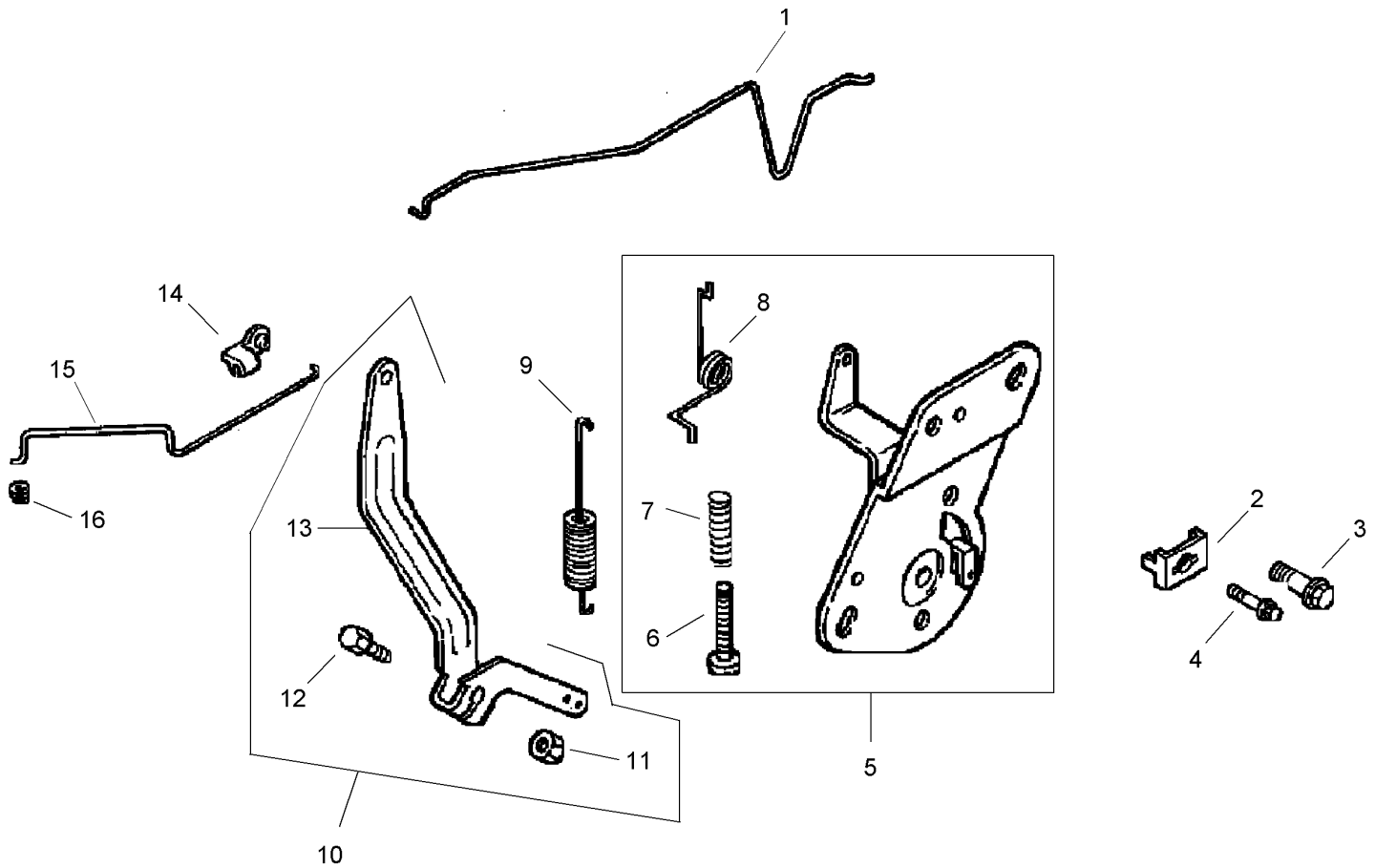

## Engine Control Assembly Kohler Cv492s-27525

Ref	Part No.	Qty.	Description
❶	12 079 11-S	1	Linkage-Choke
❷	12 237 01-S	1	Clamp-Cable
❸	M-545016-S	1	Screw-HHFTF (M5X0.8X16)
❹	M-664020-S	2	Screw-Socket, 6 Lobed (Thread Forming, M6X1.0X20)
❺	12 536 01-S	1	Control, Speed Assembly (Includes 6-8)
❻	12 086 39-S	1	Screw-Pan Head (W/Loctite)
❼	12 089 11-S	1	Spring-Control, Speed
❽	12 089 23-S	1	Spring-Return, Choke
❾	12 089 19-S	1	Spring-Governor
❿	12 755 83-S	1	Kit, Governor Lever (Includes 11-13)
⓫	12 100 07-S	1	Nut-Flange, Hex (1/4-20)
⓬	52 211 04-S	1	Bolt-Square Neck, Round Head (1/4-20X1)
⓭	12 090 28-S	1	Lever-Governor
⓮	25 158 11-S	1	Bushing-Linkage, Throttle
⓯	12 079 10-S	1	Linkage-Throttle
⓰	25 158 08-S	1	Bushing-Retaining, Linkage

# Attachments and Accessories

## For 74603 - TimeCutter ZX440 Riding Mower

Product Name	Model/Part
Light Kit .....	104-8041
Smooth Caster Wheel Kit .....	105-1856
Tire Chains .....	107-1738
French Decal Kit .....	107-2493
Armrest Kit .....	108-6163
44 Inch Vac-Bagger .....	79161
56 Inch Snow Blade .....	79165
44 Inch Recycler Kit .....	86041

