



TimeCutter™ ZX525 Riding Mower

Model No. 74806 - 260000001 and up.

Parts Catalog

Ordering Replacement Parts

To order replacement parts, please supply the part number, the quantity, and the description of each part desired.

Understanding Reference Numbers

Each identified part in an illustration has a reference number. The reference number for a part also appears in the parts list, along with other information about the part.

This catalog uses two special reference number formats, one to indicate parts in a service assembly and another to indicate the quantity of a given part in an illustration.

Service Assembly Reference Numbers

Parts in service assemblies have reference numbers in the form a:b. The a represents the reference number of the entire service assembly and the b represents a sequential number unique to each part within the service assembly.

For example, a wheel assembly might be identified by reference number 6, the tire by 6:1, the valve by 6:2, and the wheel by 6:3. When you order the assembly identified by reference number 6, you receive all parts identified by reference numbers 6:1, 6:2, and 6:3. However, you may also order any part individually. Reference numbers of this type appear in illustrations and in part lists.

Reference Numbers Indicating Quantity

In an illustration, if a reference number indicates more than one part, the reference number has the form nX y. The n represents the quantity of the part, the X is the multiplication symbol, and the y represents the reference number.

For example, in an illustration, the reference number 2X 37 means that two of the parts identified by reference number 37 are indicated.

Contents

Description	Page	Description	Page
Front Frame Assembly	3	Valve and Camshaft Assembly Kawasaki FH580V-CS13-R	22
Height-of-Cut Handle and Plate Assembly	4	Lubrication Equipment Assembly Kawasaki FH580V-CS13-R	24
Main Frame Assembly	5	Electrical Equipment Assembly Kawasaki FH580V-CS13-R	26
Fuel Tank and Control Pod Assembly	6	Cooling Equipment Assembly Kawasaki FH580V-CS13-R	28
Parking Brake Assembly	7	Carburetor Assembly Kawasaki FH580V-CS13-R	29
Motion Control Assembly	8	Control Equipment Assembly Kawasaki FH580V-CS13-R	30
Hydro and Belt Drive Assembly	9	Air Filter and Muffler Assembly Kawasaki FH580V-CS13-R	32
LH Hydro Assembly No. 108-8507	10	Fuel Tank and Fuel Valve Assembly Kawasaki FH580V-CS13-R	33
RH Hydro Assembly No. 108-8506	12	Starter Assembly Kawasaki FH580V-CS13-R	34
Engine and Clutch Assembly	14	Engine Decals Kawasaki FH580V-CS13-R	35
Electrical Assembly	15	Attachments and Accessories List	36
52in Deck Assembly	16		
52in Deck Assembly No. 108-8571	17		
Deflector Assembly No. 108-8591	18		
52in Deck Belt Drive Assembly	19		
Cylinder and Crankcase Assembly Kawasaki FH580V-CS13-R	20		
Piston and Crankshaft Assembly Kawasaki FH580V-CS13-R	21		

Part Description Abbreviations

Part descriptions in this catalog may include the following abbreviations.

AR. as required	HYD. hydraulic
ASM. assembly	LH. left hand
BBC. blade brake clutch	NI. nylon insert
CARR. carriage	NPTF. national pipe thread fine
DEG. degrees	PFH. phillips flat head
EXT. external	PPH. phillips pan head
FH. flat head	PPHTF. phillips pan head thread forming
GA. gauge	PRH. phillips round head
HD. heavy-duty	PTH. phillips truss head
HF. hex flange	PTO. power-take-off
HH. hex head	RH. right hand
HHF. hex head flange	ROPS. roll-over protection system
HHFTF. hex head flange thread forming	SFH. slotted fillister head
HJ. hex jam	SHH. slotted hex head
HLH. hex lag head	SHWH. slotted hex washer head
HOC. height-of-cut	SPH. slotted pan head
HSBH. hex socket button head	SQH. square head
HSFH. hex socket flat head	SRH. slotted round head
HSH. hex socket head	STD. standard
HWH. hex washer head	TAP. self tapping
HWHTF. hex washer head thread forming	TTH. torx truss head

Footnotes

- ❶ Not illustrated
- ❷ Obtain from your local Kawasaki dealer

- ❸ Not serviced separately

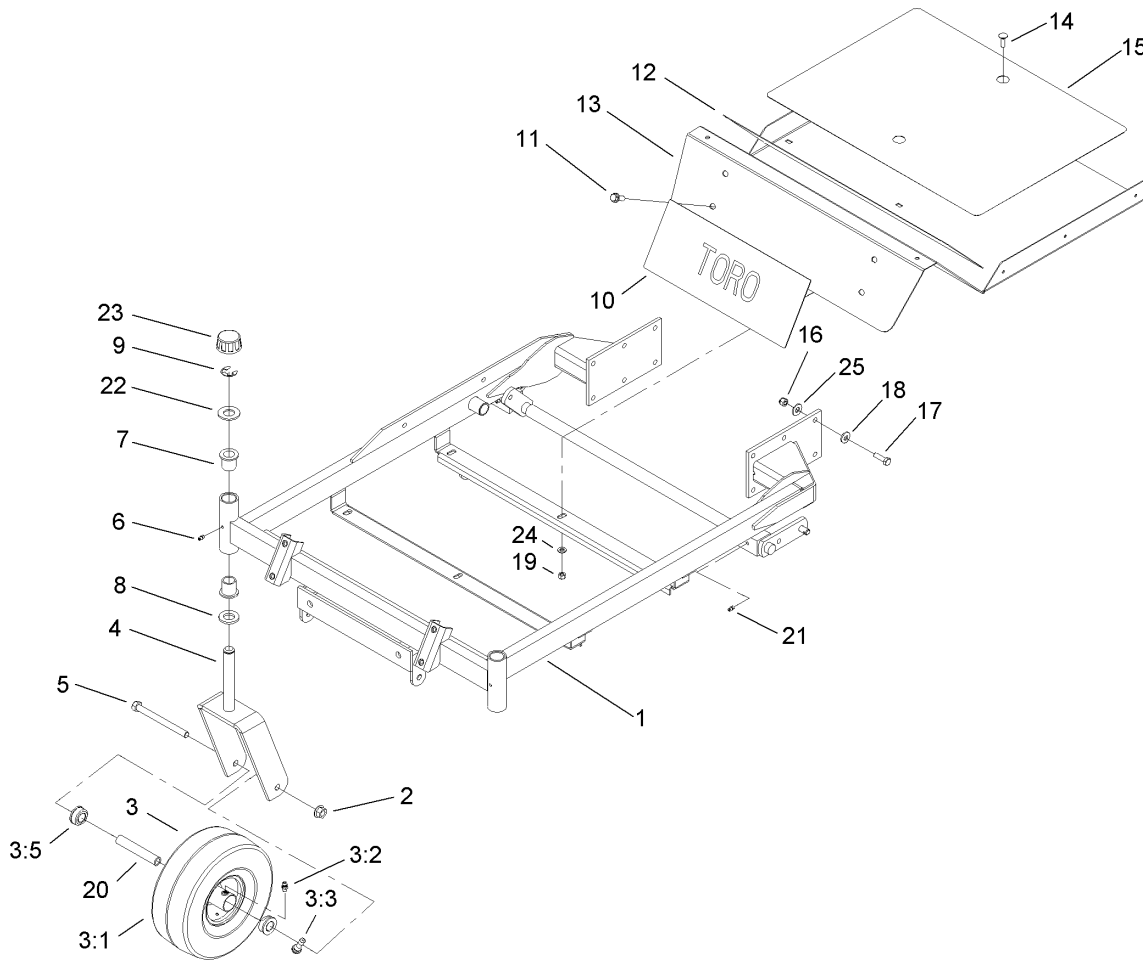

Front Frame Assembly

Ref	Part No.	Qty.	Description
1	108-2311-01	1	Carrier Frame ASM
2	32128-23	2	Nut-HF
3	105-3471	2	Front Wheel And Tire ASM
3:1	105-1943	1	Tire
3:2	302-5	1	Fitting-Grease
3:3	232-27	1	Stem-Valve
3:5	114-1640	2	Bushing-Flange
①3:99	93-4244	1	Tube-Inner (W/Valve)
4	100-7363-01	2	Caster Fork ASM
5	325-22	2	Screw-HH
6	302-5	2	Fitting-Grease
7	1-303514	4	Bearing-Flanged
8	1-513338	2	Washer-Flat
9	32151-103	2	Ring-Snap
10	67-7320	1	Decal
11	66-9300	4	Screw-HF
12	104-3639	1	Pad-Skid, Anti
13	100-7386-03	1	Floorpan
14	3230-28	6	Screw-CARR
15	104-3640	1	Pad-Skid, Anti
16	3296-39	12	Nut-Lock, NI
17	323-7	12	Screw-HH
18	98-5975	12	Washer-Belleville
19	3296-29	6	Nut-Lock, NI

Ref	Part No.	Qty.	Description
20	104-3667	2	Spanner-Wheel
21	302-19	2	Fitting-Grease
22	104-8076	2	Washer
23	61-9780	2	Cap-Hub
24	3256-23	6	Washer-Flat
25	1-809107	12	Washer-Hardened

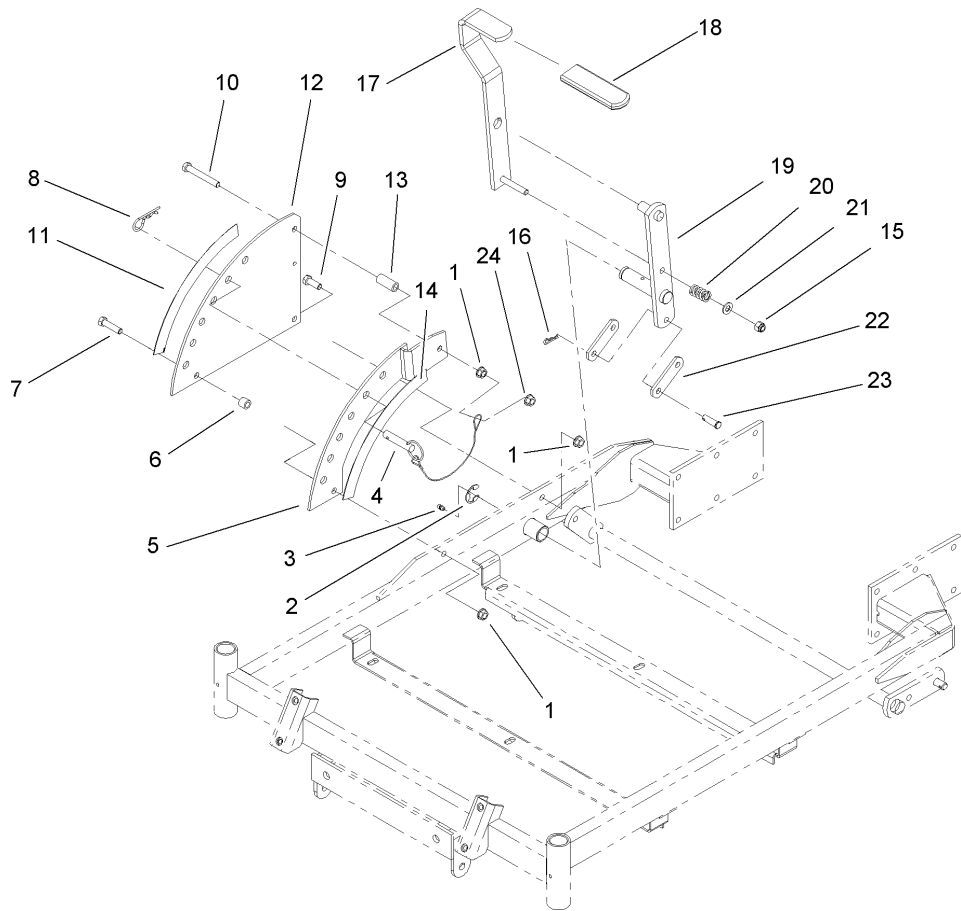

Height-of-Cut Handle and Plate Assembly

Ref	Part No.	Qty.	Description
1	3290-357	3	Nut-HHF, Whiz
2	32151-103	1	Ring-Snap
3	302-5	1	Fitting-Grease
4	104-3678	1	Pin-Hitch
5	100-7335-01	1	Plate-Lift
6	1-413088	1	Bushing-Lever, Lift
7	323-8	1	Screw-HH
8	1-806005	1	Pin-Hair
9	323-6	1	Screw-HH
10	323-13	1	Screw-HH
11	104-3641	1	Decal-Deck Height, Outer
12	100-7384-01	1	Plate-Deck Lift
13	1-633082	1	Bushing-Lever, Lift
14	104-8032	1	Decal-Deck Height, Inner
15	3296-39	1	Nut-Lock, NI
16	1-806003	2	Pin-Hair
17	1-652023-03	1	Lever-Lift
18	1-633295	1	Grip-Lever, Lift
19	1-652027-03	1	Arm-Deck, Lift
20	1-633325	1	Spring-Compression
21	3256-24	1	Washer-Flat
22	1-633068	2	Arm-Lift, Deck
23	283-2	2	Pin-Clevis
24	32128-21	1	Nut-HF

--	--	--	--

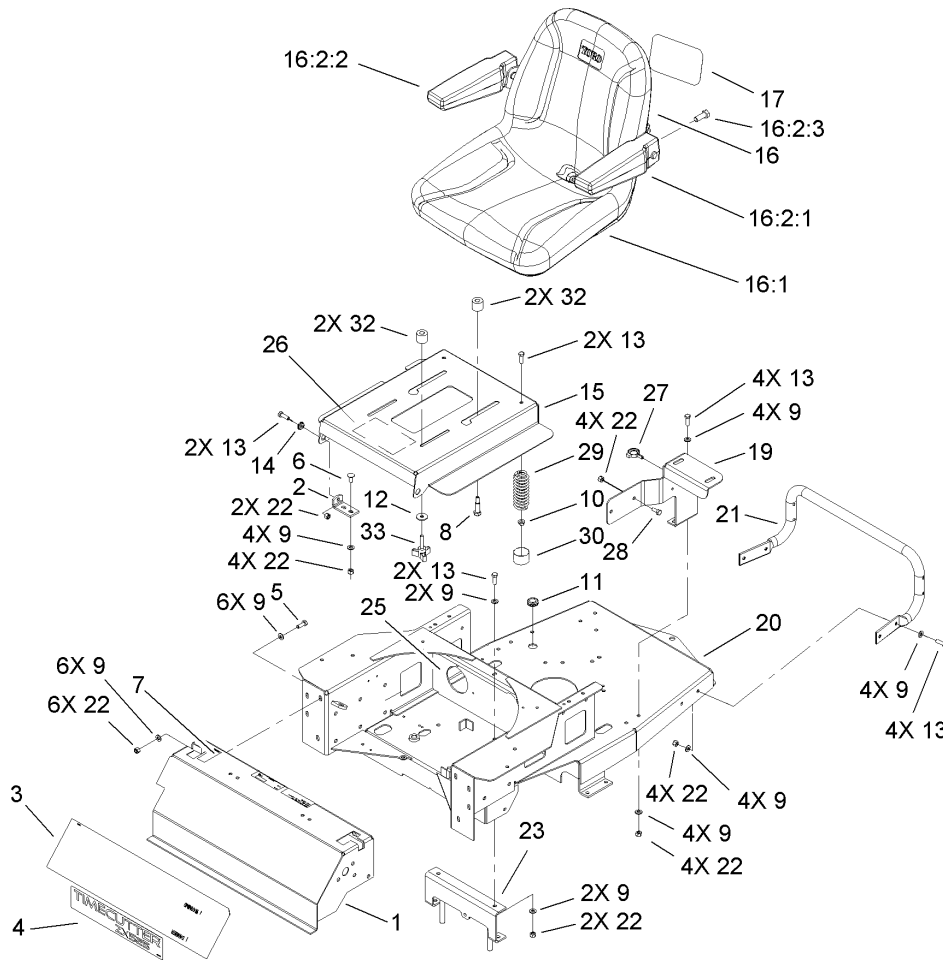

Main Frame Assembly

Ref	Part No.	Qty.	Description
1	104-8040-03	1	Console
2	104-8057-03	2	Bracket-Pivot
3	107-7399	1	Decal-Danger
4	108-7132	1	Decal
5	322-4	6	Screw-HH
6	3230-23	4	Screw-CARR
7	1-633354	2	Decal-Control, Motion
8	7-0030	2	Bolt-Shoulder
9	3256-23	36	Washer-Flat
10	32128-25	2	Nut-HF
11	237-124	1	Grommet
12	5-4460	2	Washer-Pivot
13	322-5	14	Screw-HH
14	105503	2	Bushing
15	108-9572-03	1	Seat Pan ASM
16	106-6447	1	Seat (With Arm Rests)
16:1	108-2329	1	Seat
16:2	108-6163	1	Armrest Kit
16:2:1	110-6569	1	LH Armrest Kit
16:2:2	110-6570	1	RH Armrest Kit
16:2:3	108-6179	6	Screw-HSBH
17	93-7340	1	Decal
18	100-7376-01	1	Bracket-RH
19	100-7368-01	1	Bracket-LH

Ref	Part No.	Qty.	Description
20	108-2310-01	1	Rear Frame ASM
21	100-7332-03	1	Rod-Support, Rear
22	3296-29	26	Nut-Lock, NI
23	105-6987-03	1	Bracket
25	105-1854	1	Cover-Conduit
26	107-2473	1	Decal-Service
27	105-1853	2	Clamp-Hose
28	322-3	4	Screw-HH
29	92-7054	2	Spring-Compression
30	701178	2	Cap-Protector
32	108-2327	4	Spacer
33	108-2356	2	Knob

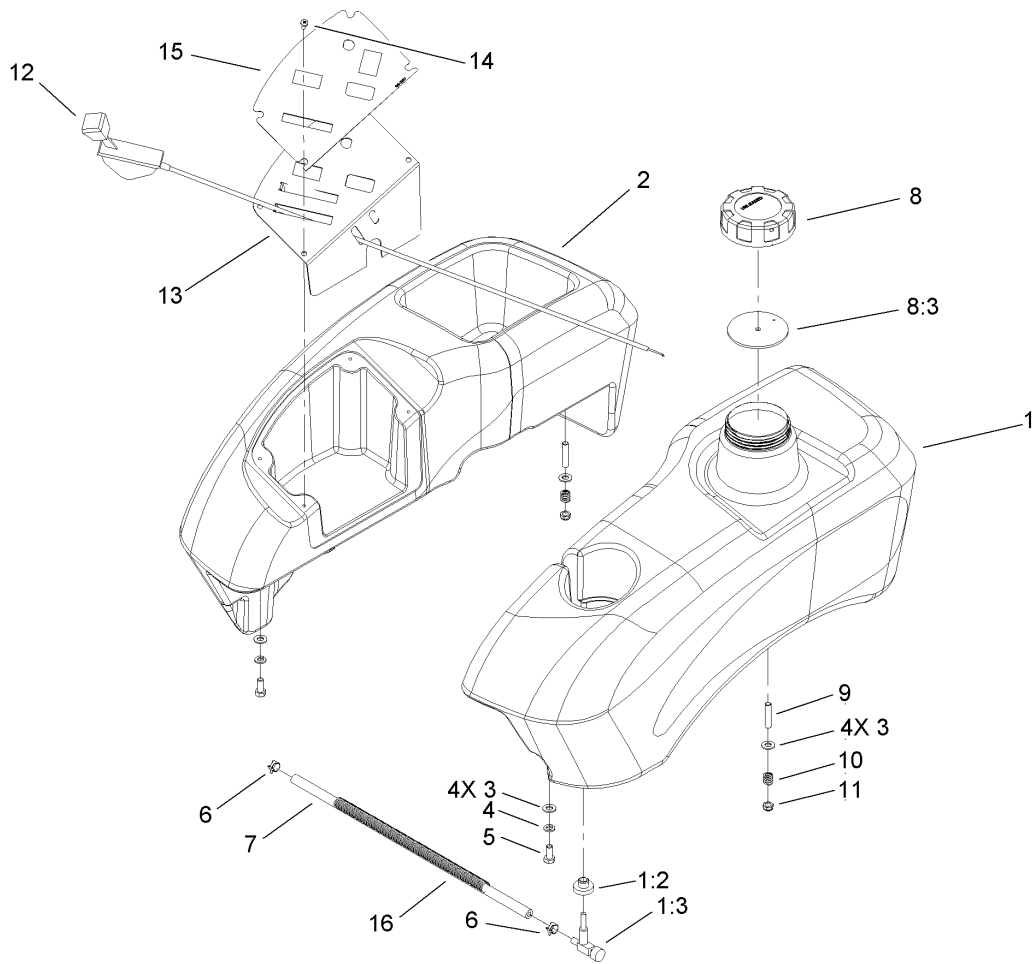

Fuel Tank and Control Pod Assembly

Ref	Part No.	Qty.	Description
1	105-3494	1	Fuel Tank ASM
1:2	46-6560	1	Bushing
1:3	110-6565	1	Valve-Fuel
2	105-1918	1	Tank-Console
3	3256-23	8	Washer-Flat
4	3253-4	4	Washer-Lock
5	322-3	4	Screw-HH
6	2412-98	2	Clamp
7	110-1872	1	Hose-Fuel
8	88-3980	1	Gas Cap ASM
8:3	88-4010	1	Gasket-Cap, Gas
9	1-633023	4	Stud
10	1-633349	4	Spring-Tank, Fuel
11	3296-47	4	Nut-Lock, NI
12	104-8081	1	Cable-Throttle
13	104-3664-03	1	Panel-Control
14	3250-14	4	Screw-PPH
15	104-8009	1	Decal-Panel, Control
16	105-1854	1	Cover-Conduit

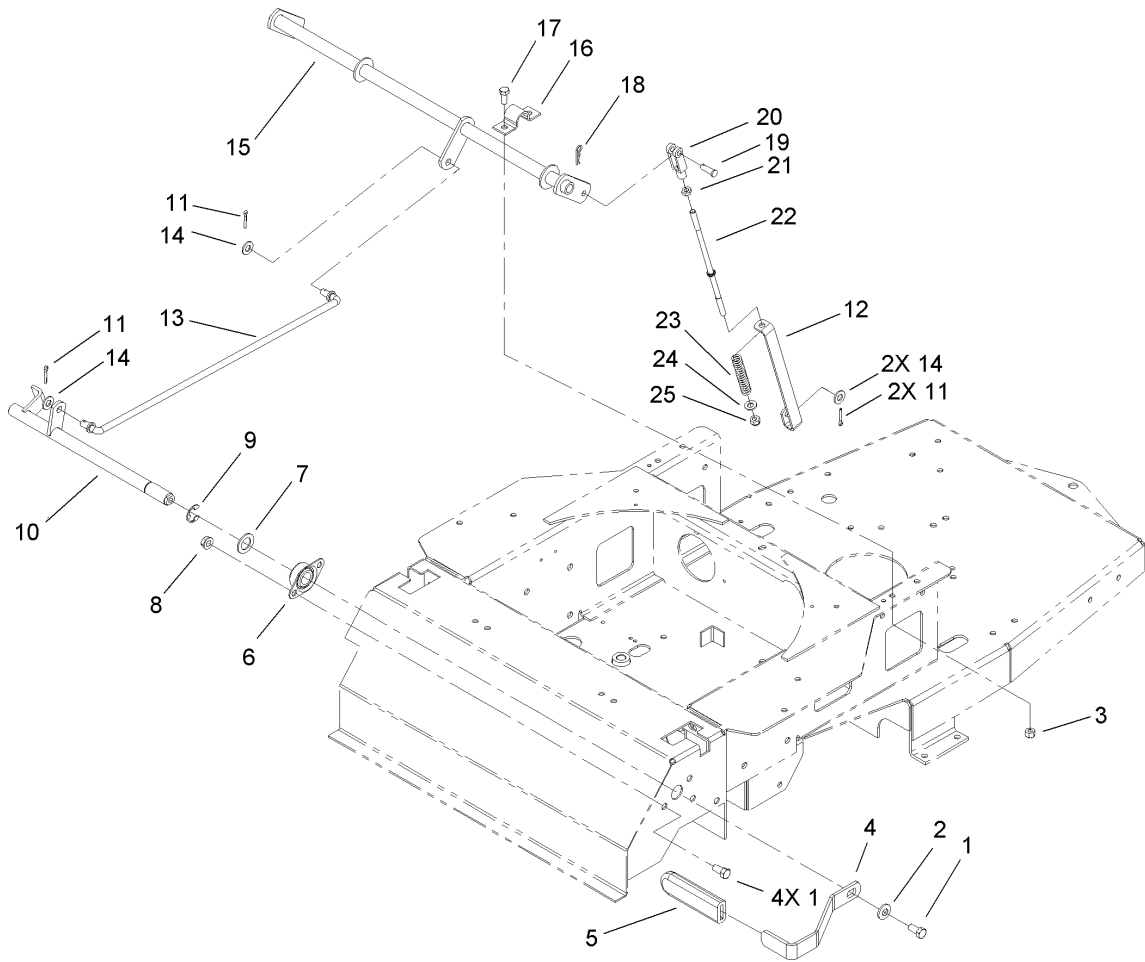

Parking Brake Assembly

Ref	Part No.	Qty.	Description
1	323-4	5	Screw-HH
2	98-5975	1	Washer-Belleville
3	3296-29	4	Nut-Lock, NI
4	100-7346-03	1	Handle-Brake, Park
5	1-633268	1	Grip-Lever, Brake
6	1-633102	2	Bearing-Flange, Side
7	1-303007	1	Washer
8	3290-357	4	Nut-HHF, Whiz
9	32151-48	1	E-Ring
10	100-7318	1	Brake Shaft ASM
11	3272-10	4	Pin-Cotter
12	104-3675	2	Bracket-Spring, Brake
13	104-8046	1	Rod-Brake, Upper
14	3256-24	4	Washer-Flat
15	104-3670-03	1	Shaft-Brake
16	88-4730	2	Clamp-Pivot, HOC
17	322-3	4	Screw-HH
18	1-806003	2	Pin-Hair
19	1-808280	2	Pin-Clevis
20	1-303105	2	Yoke-Adjustable
21	3219-2	2	Nut-Hex
22	104-3674	2	Rod-Brake, Upper
23	38-4520	2	Spring
24	3256-23	2	Washer-Flat

Ref	Part No.	Qty.	Description
25	3296-4	2	Nut-Lock

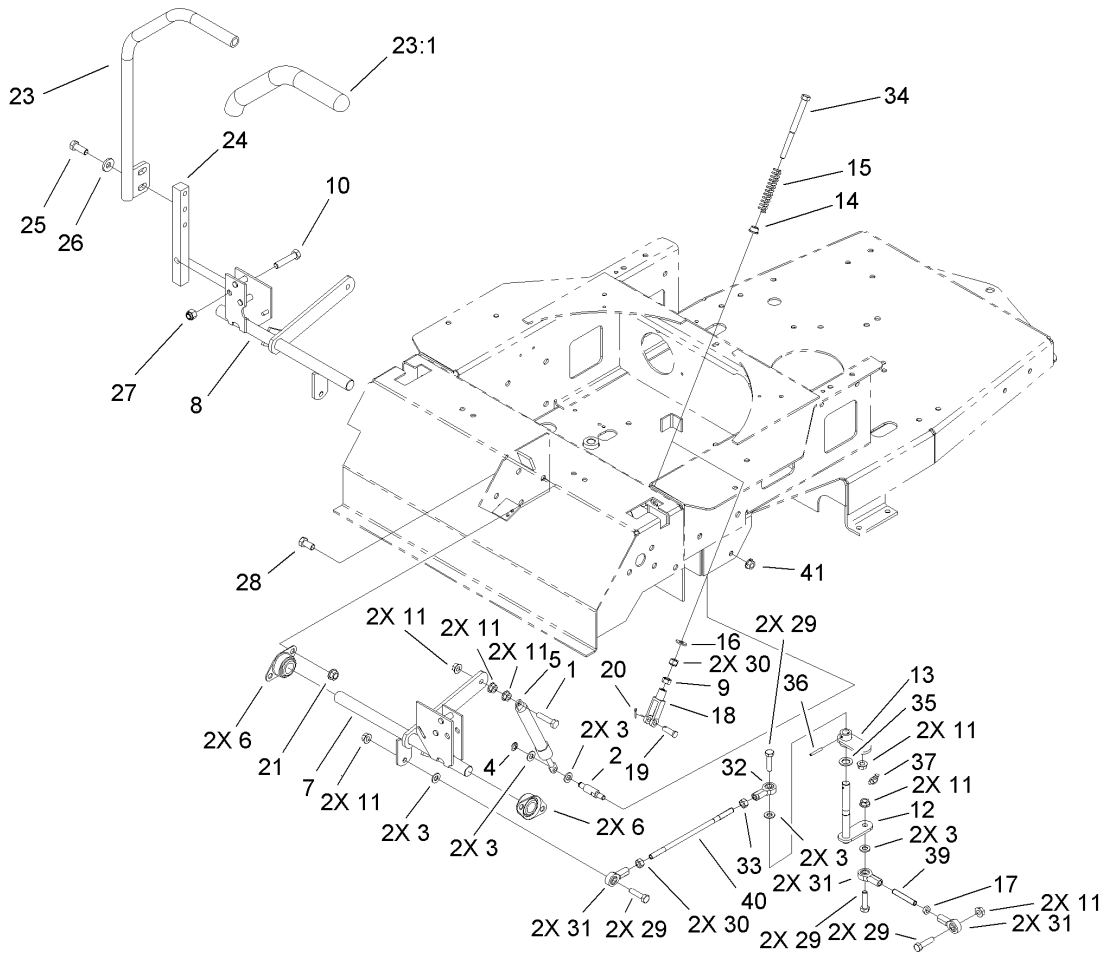

Motion Control Assembly

Ref	Part No.	Qty.	Description
1	1-403180	2	Screw-HH
2	1-653316	2	Pin-Damper
3	3256-23	10	Washer-Flat
4	32120-35	2	Ring-Retaining, EXT
5	103-2913	2	Damper-Control, Motion
6	1-633102	4	Bearing-Flange, Side
7	100-7341	1	Bracket-Motion Control, LH
8	100-7340	1	Bracket-Motion Control, RH
9	3296-4	2	Nut-Lock
10	323-9	2	Screw-HH
11	32128-20	14	Nut-HF
12	100-7311	2	Pivot ASM
13	100-7313	2	Pivot Plate ASM
14	1-603735	2	Bushing-Flanged
15	1-603807	2	Spring-Return, Neutral
16	3256-2	2	Washer-Flat
17	3220-2	2	Nut-Jam
18	1-303105	2	Yoke-Adjustable
19	1-808280	2	Pin-Clevis
20	3272-5	2	Pin-Cotter
21	3290-357	6	Nut-HHF, Whiz
①22	103-0631	1	LH Lever ASM
①22:1	1-633257	1	Grip-Control, Motion
23	103-0632	1	RH Lever ASM

Ref	Part No.	Qty.	Description
23:1	1-633257	1	Grip-Control, Motion
24	103-0407	2	Arm-Shaft, Control
25	323-6	4	Screw-HH
26	98-5975	4	Washer-Belleville
27	3296-39	2	Nut-Lock, NI
28	323-4	6	Screw-HH
29	322-5	8	Screw-HH
30	3219-2	4	Nut-Hex
31	1-543017	6	Balljoint-RH
32	1-633152	2	Balljoint-LH
33	1-804524	2	Nut
34	1-603737	2	Bolt-Return, Neutral
35	100-7336	2	Washer
36	933156	2	Pin-Roll
37	302-11	2	Fitting-Lube, 45 DEG
①38	104-3606	1	Linkage-Lower, RH
39	104-3607	1	Linkage-Lower, LH
40	104-3605	2	Linkage-Upper
41	32128-20	2	Nut-HF

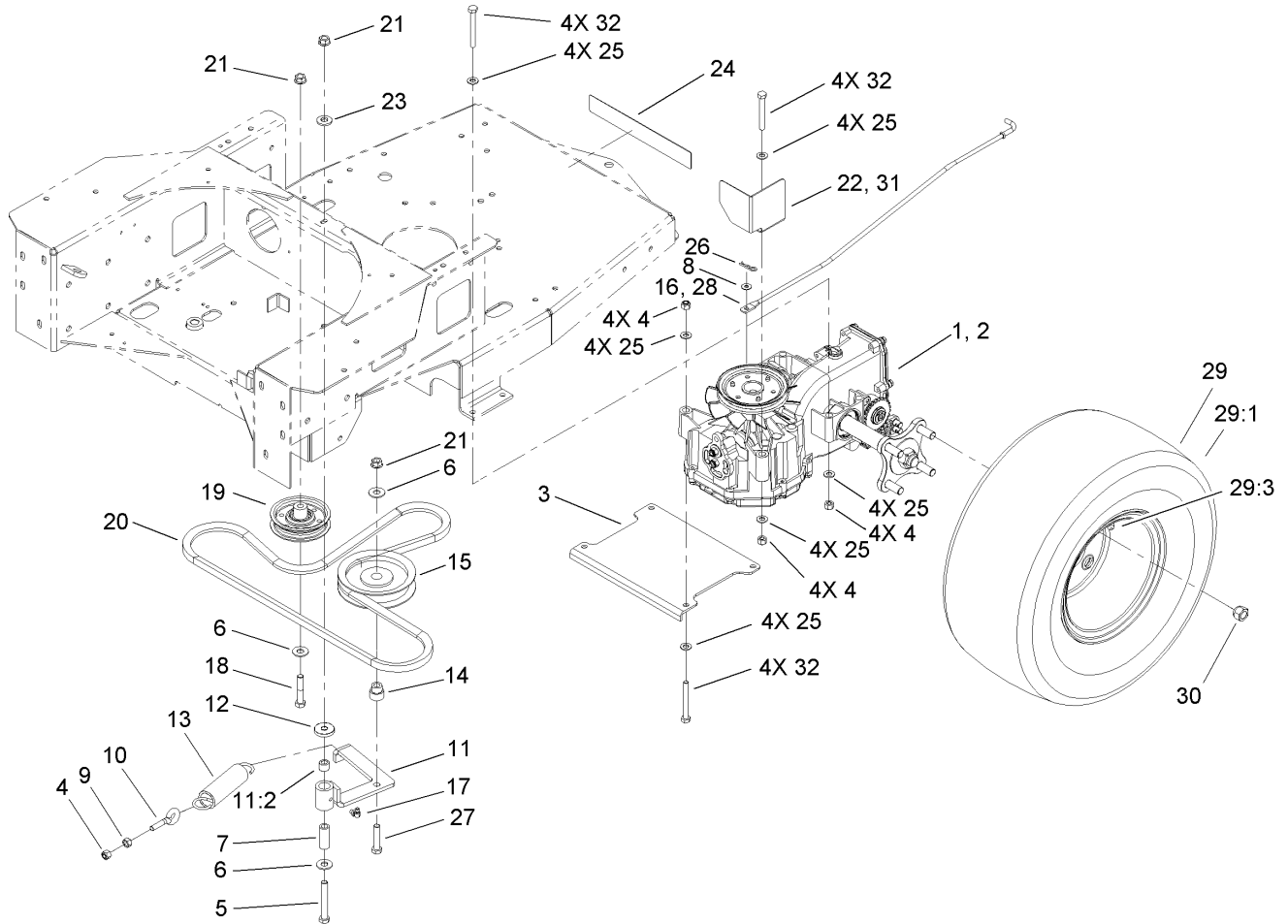

Hydro and Belt Drive Assembly

Ref	Part No.	Qty.	Description
1	108-8507	1	Hydro-LH
❶2	108-8506	1	Hydro-RH
3	100-7317-03	1	Plate-Hydro, Lower
4	3296-29	13	Nut-Lock, NI
5	323-13	1	Screw-HH
6	3256-4	3	Washer-Flat
7	1-603044	1	Bushing
8	3256-1	2	Washer-Flat
9	32128-20	1	Nut-HF
10	55-9420	1	Bolt-Eye
11	104-3614	1	Idler Arm ASM
11:2	1-513034	2	Sleeve-Bearing
12	104-8005	1	Spacer
13	1-603414	1	Spring-Extension
14	1-603496	1	Bushing-Idler
15	1-603843	1	Pulley-Idler
❶16	104-3668	1	Rod-RH
17	302-40	1	Fitting-Grease
18	323-10	1	Screw-HH
19	104-3630	1	Pulley-Idler
20	104-3622	1	Belt-V
21	32128-21	3	Nut-HF
22	104-8033-03	1	Guard-Fan, LH
23	98-5975	1	Washer-Belleville

Ref	Part No.	Qty.	Description
24	104-8061	1	Decal
25	3256-23	24	Washer-Flat
26	1-806003	2	Pin-Hair
27	323-9	1	Screw-HH
28	104-3669	1	Rod-LH
❶29		2	Wheel And Tire ASM
29:1	105-1945	1	Tire
29:3	232-27	1	Stem-Valve
❶29:4	105-4070	1	Tube-Inner
30	242-50	8	Nut-Lug
❶31	104-8013-03	1	Guard-Fan, RH
32	322-13	12	Screw-HH

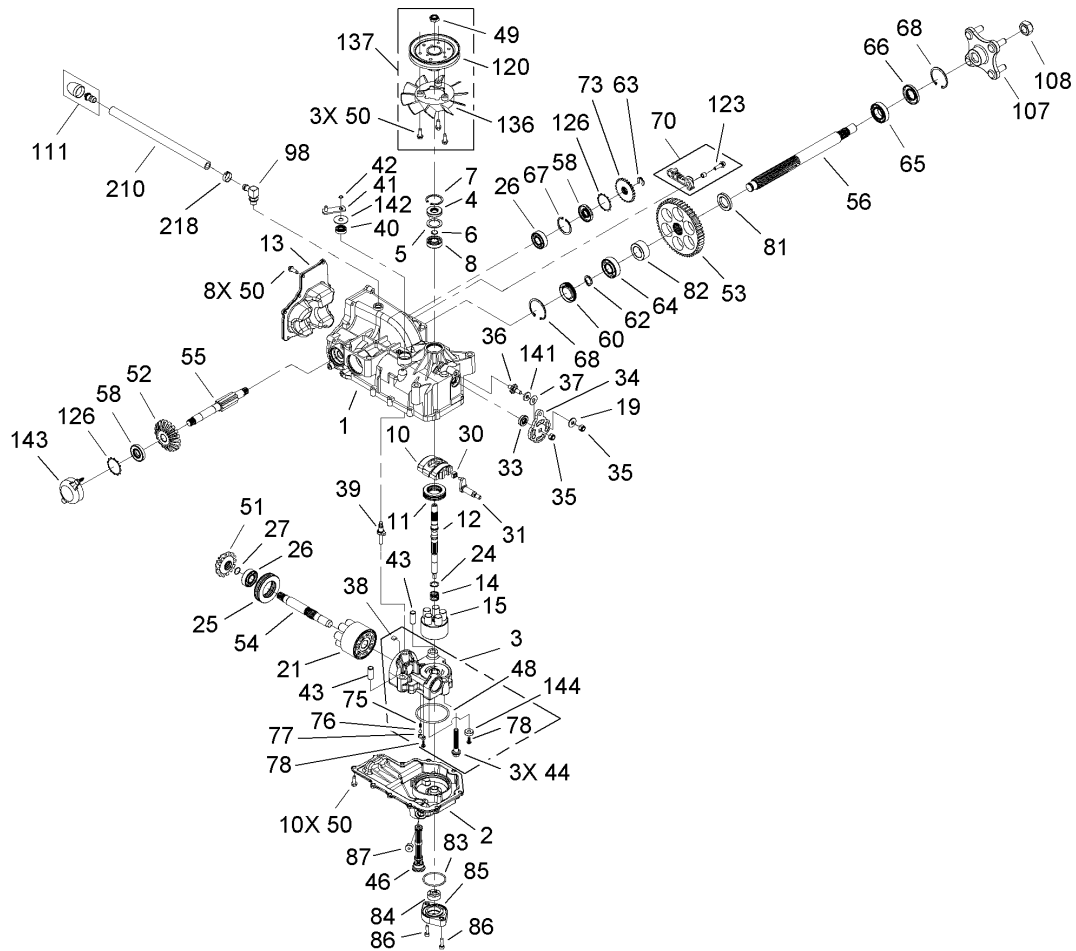

LH Hydro Assembly No. 108-8507

Ref	Part No.	Qty.	Description
1	107-1700	1	Main Housing Kit
2	108-8541	1	Housing-Lower
3	108-8542	1	Center Section Kit
4	92-6543	1	Seal-Lip
5	104-2104	1	Spacer
6	94-1902	1	Ring-Wire, Retaining
7	94-1903	1	Ring-Retaining
8	94-1904	1	Bearing-Shaft, Ball
10	94-1907	1	Swashplate-Variable
11	94-6922	1	Bearing-Thrust
12	108-8543	1	Shaft-Input
13	105-1870	1	Cover-Back
14	94-1936	1	Spring-Block
15	104-2106	1	Cylinder Block ASM
19	5-4460	1	Washer-Pivot
21	94-1913	1	Cylinder Block ASM
24	94-1937	1	Washer-Block, Thrust
25	94-6923	1	Bearing-Thrust
26	104-5311	2	Bearing-Ball
27	104-5307	1	Ring-Retaining
30	94-1910	1	Guide-Slot
31	104-2112	1	Trunnion ASM
33	92-6544	1	Seal-Lip
34	105-1871	1	Arm-Control

Ref	Part No.	Qty.	Description
35	105-1872	2	Nut
36	104-2116	1	Stud
37	105-1873	1	Puck-Friction
38	94-6925	1	Plate-Bypass
39	94-1914	1	Actuator-Bypass
40	92-6545	1	Seal-Lip
41	104-2117	1	Arm-Bypass
42	936109	1	Ring-Retaining
43	94-1927	2	Pin
44	94-6926	3	Bolt
46	108-8544	1	Filter ASM
48	108-8545	1	O-Ring
49	105-1875	1	Nut-Lock
50	104-2120	21	Screw
51	105-1876	1	Gear-Bevel, 14T
52	105-1877	1	Gear-Bevel, 19T
53	105-1878	1	Gear-Bevel, 53T
54	105-1879	1	Shaft-Motor
55	105-1880	1	Shaft-Brake
56	105-1881	1	Shaft-Axle
58	104-5310	2	Seal-Lip
60	105-1882	1	Plug-Side Seal
62	105-1883	1	Ring-Axle, Retaining
63	105-1884	1	Ring-Retaining

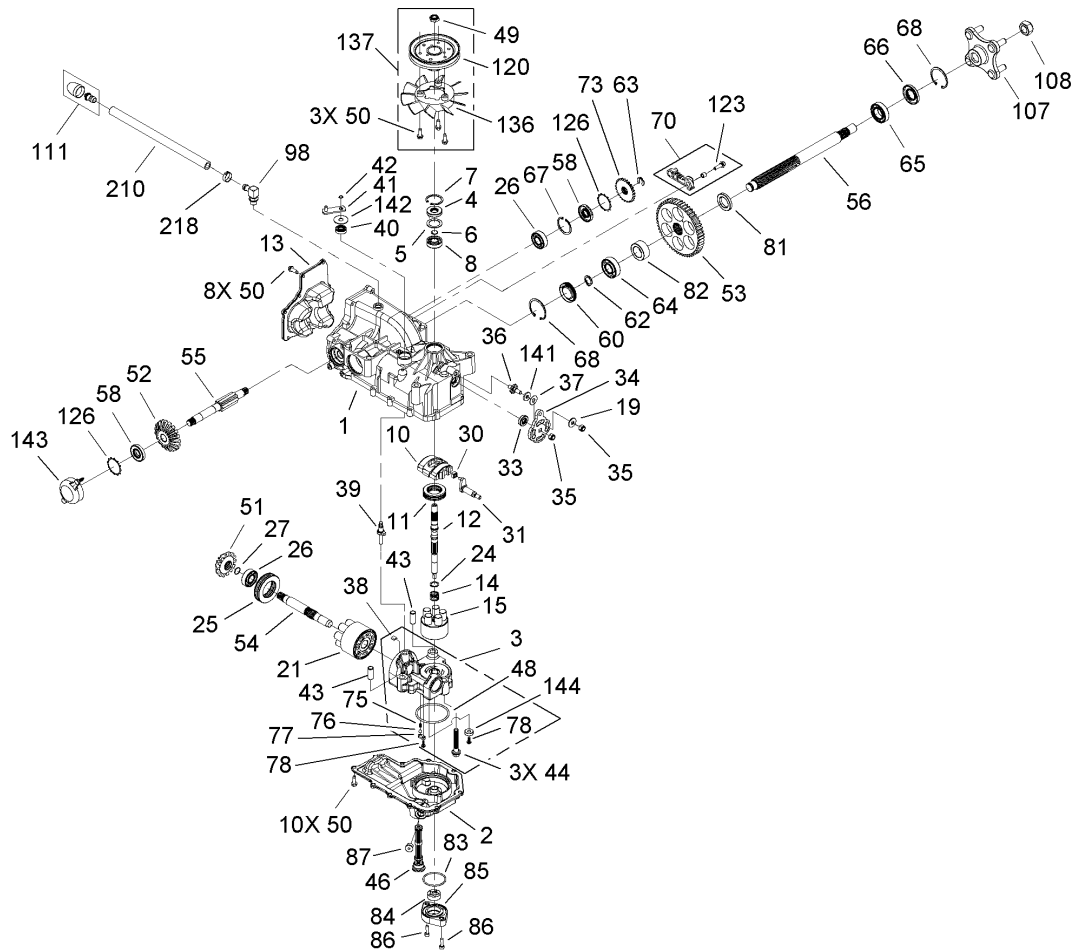

LH Hydro Assembly No. 108-8507 (continued)

Ref	Part No.	Qty.	Description
64	105-1885	1	Bearing-Ball
65	105-1886	1	Bearing-Ball
66	105-1887	1	Seal
67	104-5309	1	Ring-Retaining
68	105-1888	2	Ring-Retaining, Axle
70	108-8547	1	RH Brake Arm ASM
73	105-1890	1	Disc-Brake
75	108-8548	1	Spring-Helical
76	108-8549	1	Ball-1/4In
77	108-8550	1	Plate-Relief
78	104-5352	2	Bolt-Tapping, Self
81	108-8552	1	Spacer
82	108-8553	1	Spacer
83	106-8757	1	O-Ring
84	104-2122	1	Gerotor ASM
85	104-2124	1	Cover-Gerotor
86	106-8758	2	Screw-HSH
87	104-2184	1	Spring-Arm, Brake
98	108-8559	1	Fitting-90 DEG
●100	104-2147	1	Sealant
107	105-1894	1	Hub ASM
108	105-1895	1	Nut
111	107-1701	1	Cap Vent ASM
120	104-1754	1	Pulley

Ref	Part No.	Qty.	Description
123	107-1703	1	Screw-HHF
126	105-1898	2	Ring-Retaining
●134	105-1899	1	Seal Kit
136	105-1927	1	Fan
137	105-1928	1	Fan Pulley Kit
141	107-1705	1	Washer
142	107-1706	1	Washer
143	107-1707	1	Cover-Brake, Plastic
144	104-5330	1	Magnet-Ring
210	108-8561	1	Hose
218	108-8562	1	Pinch-Clamp, Single Ear

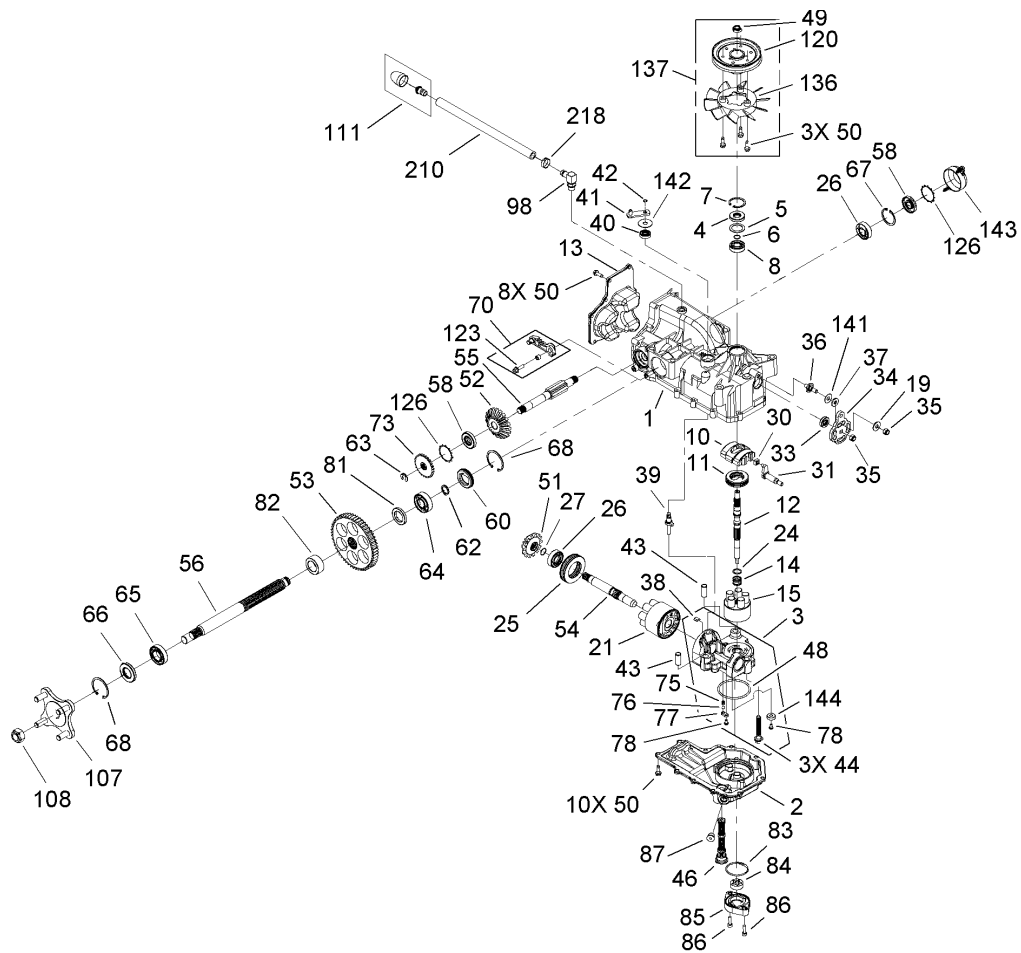

RH Hydro Assembly No. 108-8506

Ref	Part No.	Qty.	Description
1	107-1700	1	Main Housing Kit
2	108-8541	1	Housing-Lower
3	108-8542	1	Center Section Kit
4	92-6543	1	Seal-Lip
5	104-2104	1	Spacer
6	94-1902	1	Ring-Wire, Retaining
7	94-1903	1	Ring-Retaining
8	94-1904	1	Bearing-Shaft, Ball
10	94-1907	1	Swashplate-Variable
11	94-6922	1	Bearing-Thrust
12	108-8543	1	Shaft-Input
13	105-1870	1	Cover-Back
14	94-1936	1	Spring-Block
15	104-2106	1	Cylinder Block ASM
19	5-4460	1	Washer-Pivot
21	94-1913	1	Cylinder Block ASM
24	94-1937	1	Washer-Block, Thrust
25	94-6923	1	Bearing-Thrust
26	104-5311	2	Bearing-Ball
27	104-5307	1	Ring-Retaining
30	94-1910	1	Guide-Slot
31	104-2112	1	Trunnion ASM
33	92-6544	1	Seal-Lip
34	105-1871	1	Arm-Control

Ref	Part No.	Qty.	Description
35	105-1872	2	Nut
36	104-2116	1	Stud
37	105-1873	1	Puck-Friction
38	94-6925	1	Plate-Bypass
39	94-1914	1	Actuator-Bypass
40	92-6545	1	Seal-Lip
41	104-2117	1	Arm-Bypass
42	936109	1	Ring-Retaining
43	94-1927	2	Pin
44	94-6926	3	Bolt
46	108-8544	1	Filter ASM
48	108-8545	1	O-Ring
49	105-1875	1	Nut-Lock
50	104-2120	21	Screw
51	105-1876	1	Gear-Bevel, 14T
52	105-1877	1	Gear-Bevel, 19T
53	105-1878	1	Gear-Bevel, 53T
54	105-1879	1	Shaft-Motor
55	105-1880	1	Shaft-Brake
56	105-1881	1	Shaft-Axle
58	104-5310	2	Seal-Lip
60	105-1882	1	Plug-Side Seal
62	105-1883	1	Ring-Axle, Retaining
63	105-1884	1	Ring-Retaining

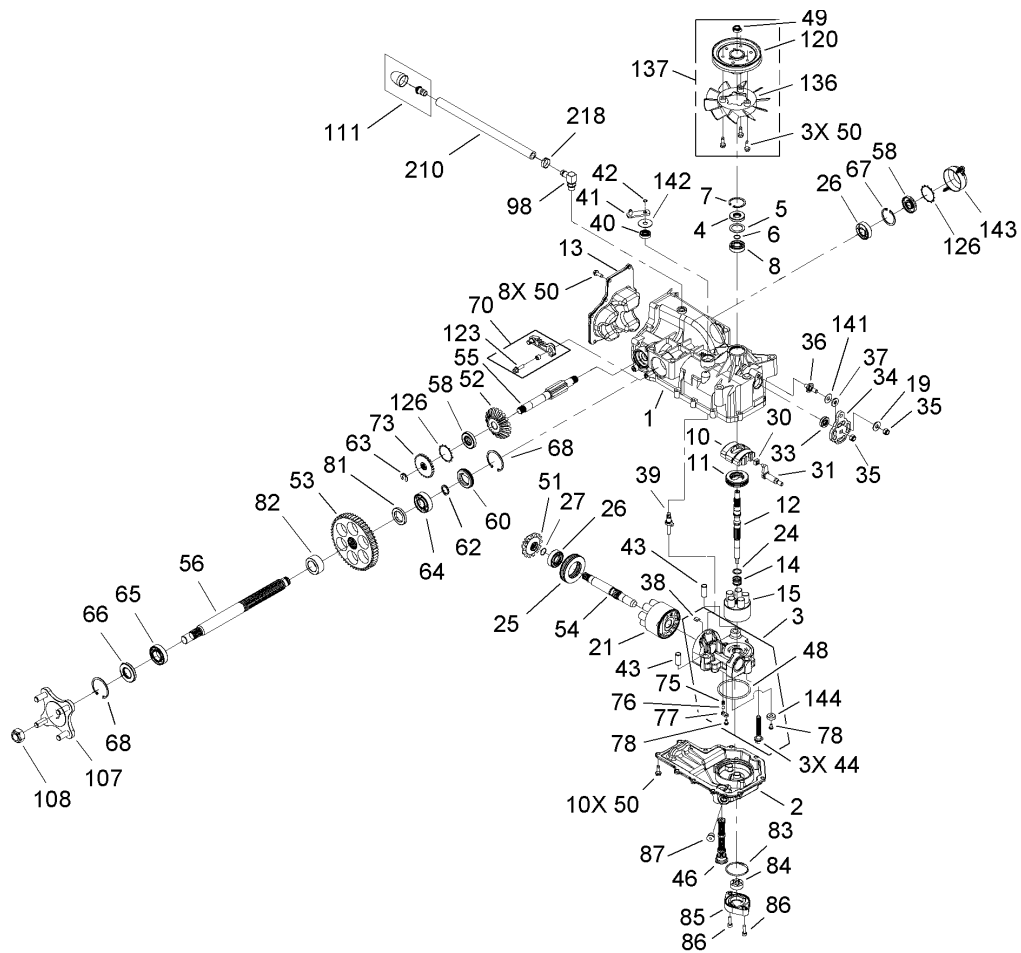

RH Hydro Assembly No. 108-8506 (continued)

Ref	Part No.	Qty.	Description
64	105-1885	1	Bearing-Ball
65	105-1886	1	Bearing-Ball
66	105-1887	1	Seal
67	104-5309	1	Ring-Retaining
68	105-1888	2	Ring-Retaining, Axle
70	108-8546	1	LH Brake Arm ASM
73	105-1890	1	Disc-Brake
75	108-8548	1	Spring-Helical
76	108-8549	1	Ball-1/4In
77	108-8550	1	Plate-Relief
78	104-5352	2	Bolt-Tapping, Self
81	108-8552	1	Spacer
82	108-8553	1	Spacer
83	106-8757	1	O-Ring
84	104-2122	1	Gerotor ASM
85	104-2124	1	Cover-Gerotor
86	106-8758	2	Screw-HSH
87	104-2184	1	Spring-Arm, Brake
98	108-8559	1	Fitting-90 DEG
●100	104-2147	1	Sealant
107	105-1894	1	Hub ASM
108	105-1895	1	Nut
111	107-1701	1	Cap Vent ASM
120	105-1896	1	Pulley

Ref	Part No.	Qty.	Description
123	107-1703	1	Screw-HHF
126	105-1898	2	Ring-Retaining
●134	105-1899	1	Seal Kit
136	105-1927	1	Fan
137	105-1928	1	Fan Pulley Kit
141	107-1705	1	Washer
142	107-1706	1	Washer
143	107-1707	1	Cover-Brake, Plastic
144	104-5330	1	Magnet-Ring
210	108-8561	1	Hose
218	108-8562	1	Pinch-Clamp, Single Ear

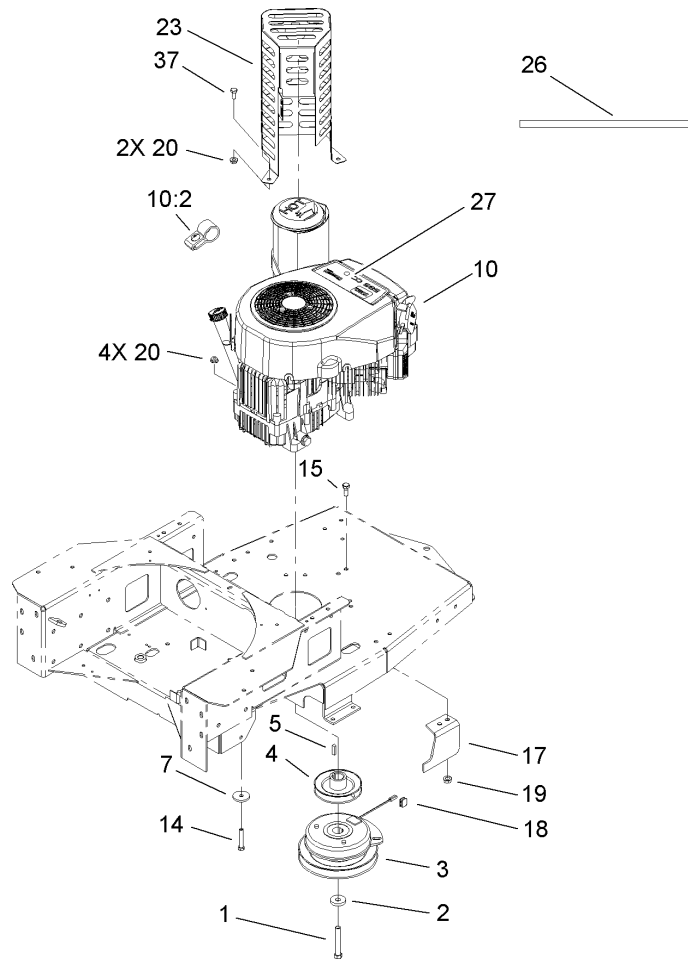

Engine and Clutch Assembly

Ref	Part No.	Qty.	Description
1	3212-12	1	Screw-HH
2	112843	1	Washer
3	108-9512	1	Clutch-PTO, Electric
4	100-7314	1	Pump Drive Pulley ASM
5	5-7280	1	Key
7	62-7190	4	Spacer-Steel
10		1	Engine-Kawasaki, FH580V-Cs13
10:2	100-6468	1	Clamp-Muffler
14	322-9	4	Screw-HH
15	323-4	2	Screw-HH
17	104-3613-03	1	Stop-Clutch
18	98-5023	1	Bumper
19	32128-21	2	Nut-HF
20	32128-25	6	Nut-HF
23	110-1886-03	1	Muffler Guard ASM
26	106-7022	1	Tube-Drain, Oil
27	107-9246	1	Decal
37	322-3	2	Screw-HH

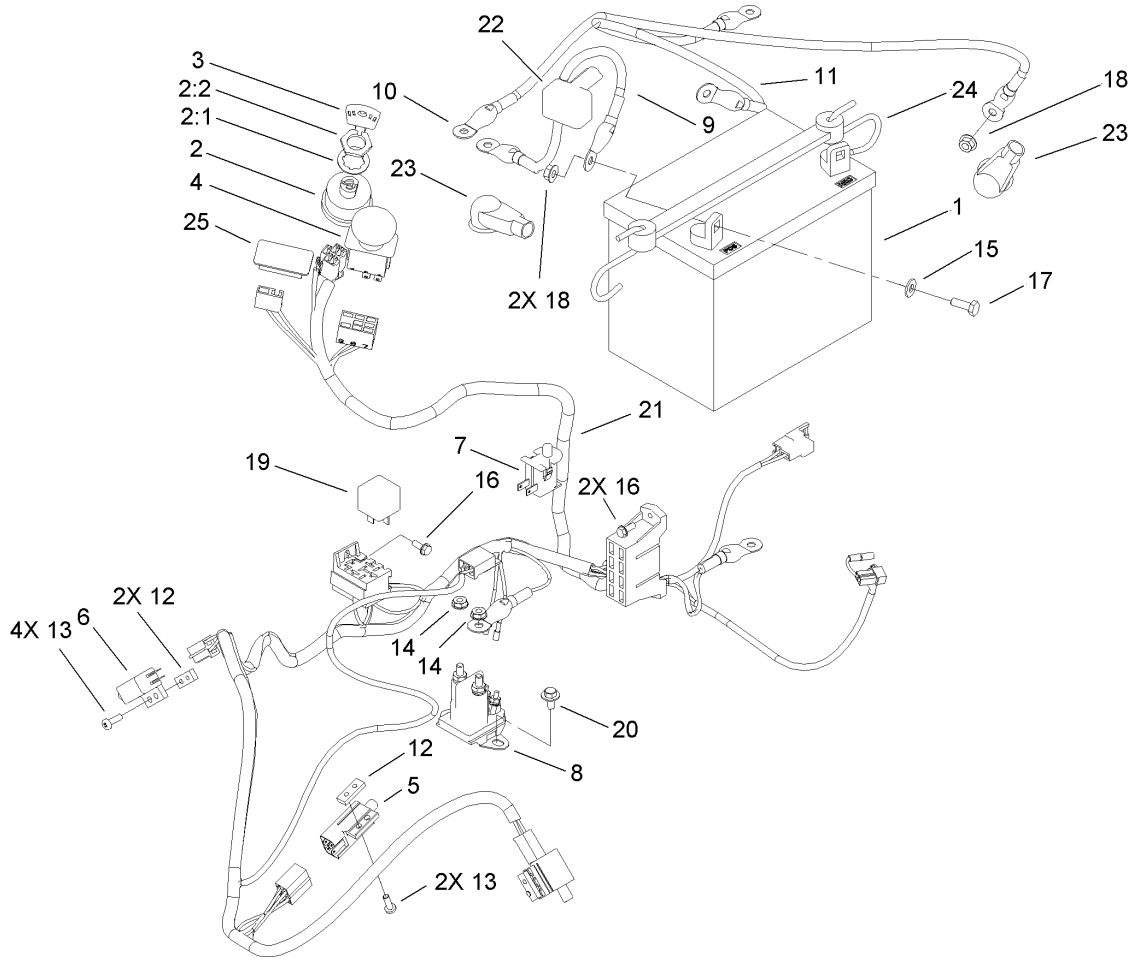

Electrical Assembly

Ref	Part No.	Qty.	Description
1	104-2491	1	Battery-Dry
2	88-9830	1	Key Switch ASM
2:1	3254-5	1	Washer-Tooth
2:2	218-461	1	Nut-HH
3	63-8360	1	Key-Ignition
4	95-7489	1	Switch-PTO
5	86-4690	1	Switch-Interlock
6	65-7410	2	Switch-Pole, Single
7	82-2190	1	Switch-Bail
8	106-8245	1	Solenoid
9	56-7670	1	Wire ASM
10	54-2030	1	Wire ASM
11	93-0324	1	Cable
12	1-633181	3	Plate-Tapped
13	32144-8	6	Screw-PPHTF
14	32149-2	2	Nut-Keps
15	3256-22	2	Washer-Flat
16	32144-1	3	Screw-Taptite
17	321-4	2	Screw-HH
18	32128-33	3	Nut-HF
19	98-7249	1	Relay
20	46-8560	2	Screw-HHF
21	107-2504	1	Harness-Wire
22	28-8080	1	Boot-Terminal

Ref	Part No.	Qty.	Description
23	93-3190	2	Boot-Insulator, Terminal
24	104-2466	1	Holddown-Battery
25	99-7420	1	Plug-Hole

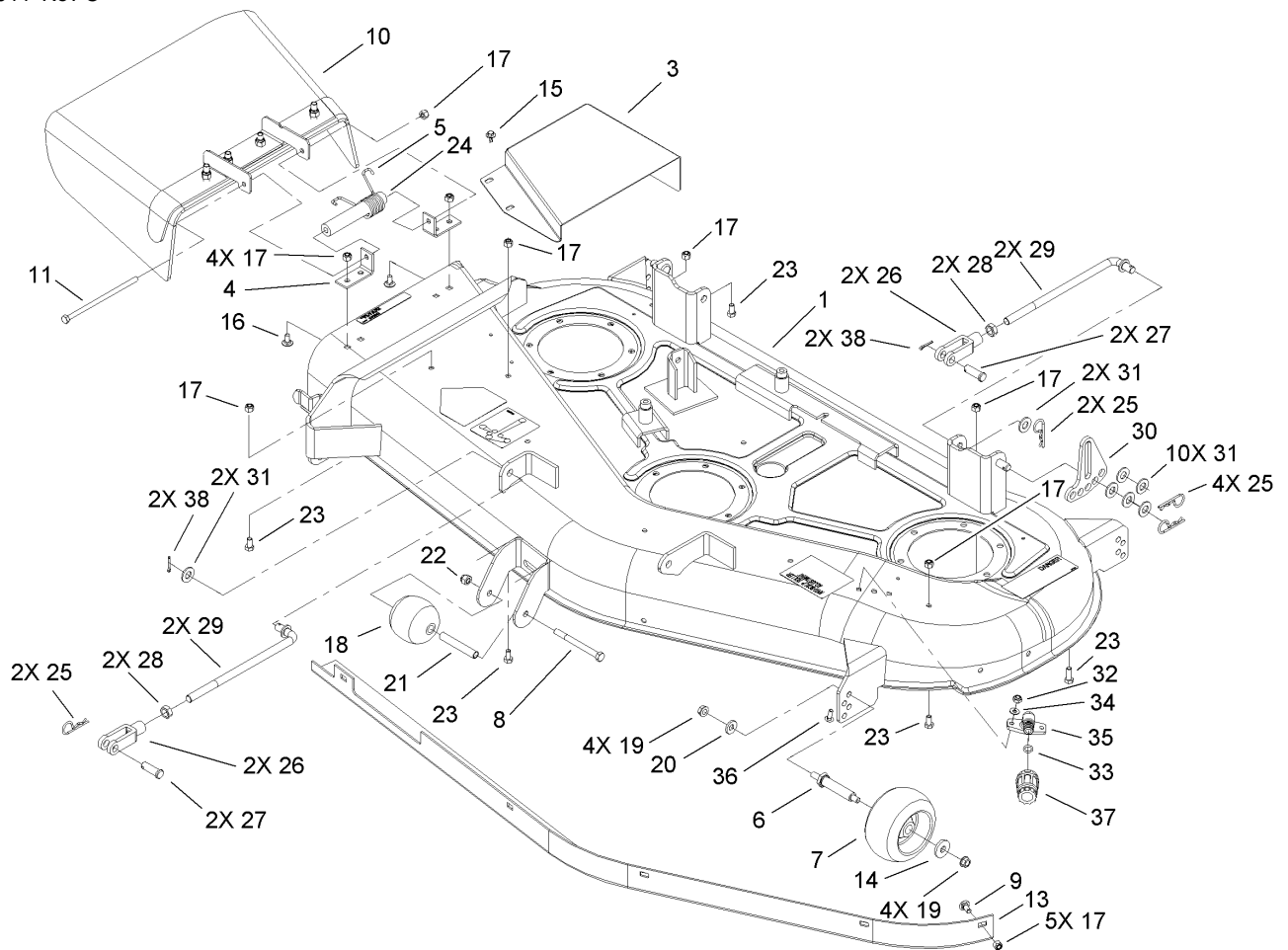

52in Deck Assembly

Ref	Part No.	Qty.	Description
1	108-8571	1	52 Inch Deck ASM
❶ 2	108-8532-03	1	Cover-Belt, LH
3	108-8531-03	1	Cover-Belt, RH
4	108-6196-03	2	Bracket-Pivot, Deflector
5	108-4052	1	Spring-Torsion
6	99-2842	4	Spacer
7	1-603299	4	Roller-Scalp, Anti
8	323-16	1	Screw-HH
9	3230-18	5	Screw-CARR
10	108-8591	1	Deflector ASM
11	108-8539	1	Bolt-HH
13	67-2150-03	1	Baffle
14	1-373034	4	Washer
15	46-8560	5	Screw-HHF
16	3230-18	4	Screw-CARR
17	3296-29	15	Nut-Lock, NI
18	29-4820	1	Roller
19	3290-357	8	Nut-HHF, Whiz
20	98-5975	4	Washer-Belleville
21	94-2500	1	Tube-Spacer, Wheel
22	3296-39	1	Nut-Lock, NI
23	322-2	5	Screw-HH
24	108-7159	1	Spacer-Deflector
25	1-806005	8	Pin-Hair

Ref	Part No.	Qty.	Description
26	100-7338	4	Clevis
27	104-3634	4	Pin-Clevis
28	3220-5	4	Nut-Jam
29	104-8047	4	Rod-Trunion
30	104-3699-01	2	Link-HOC, Adjusting
31	3256-26	14	Washer-Flat
32	3296-16	2	Nut-Lock, NI
33	46-6290	1	O-Ring
34	3256-1	2	Washer-Flat
35	95-2747	1	Fitting-Washout
36	3229-1	2	Screw-CARR
37	95-3270	1	Connector-Hose
38	3272-10	4	Pin-Cotter

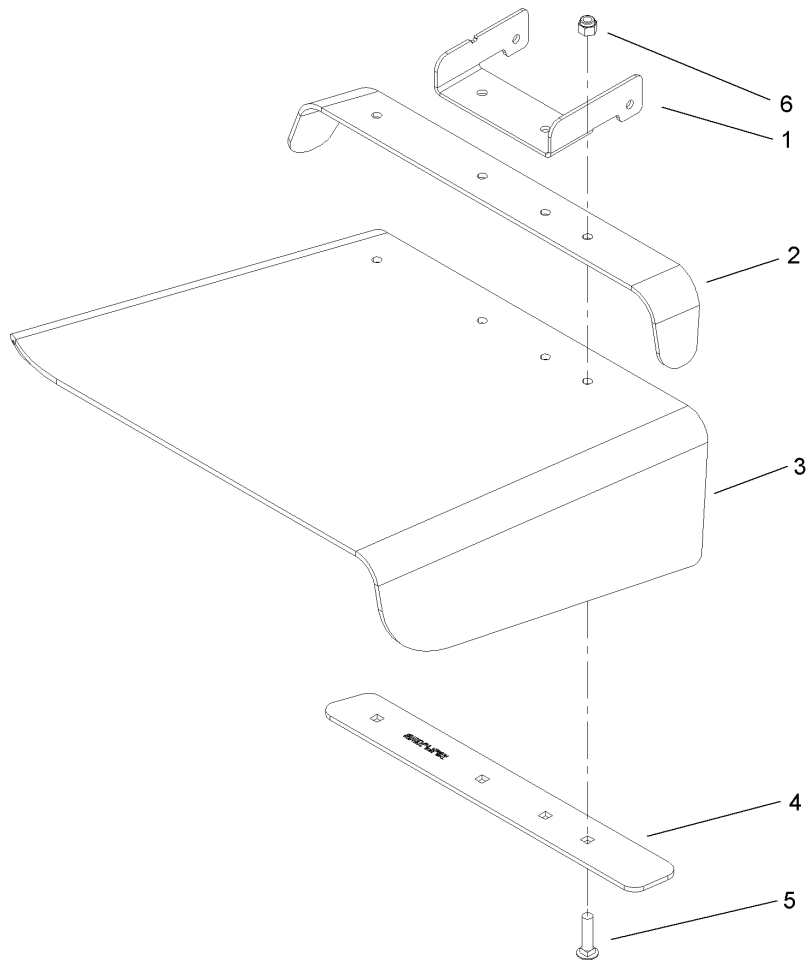

Deflector Assembly No. 108-8591

Ref	Part No.	Qty.	Description
1	108-6184-03	1	Hinge-Deflector
2	108-6172-03	1	Support-Discharge
3	108-8590	1	Deflector-Rubber
4	108-6174-03	1	Strap-Discharge
5	3230-3	4	Screw-CARR
6	3296-29	4	Nut-Lock, NI

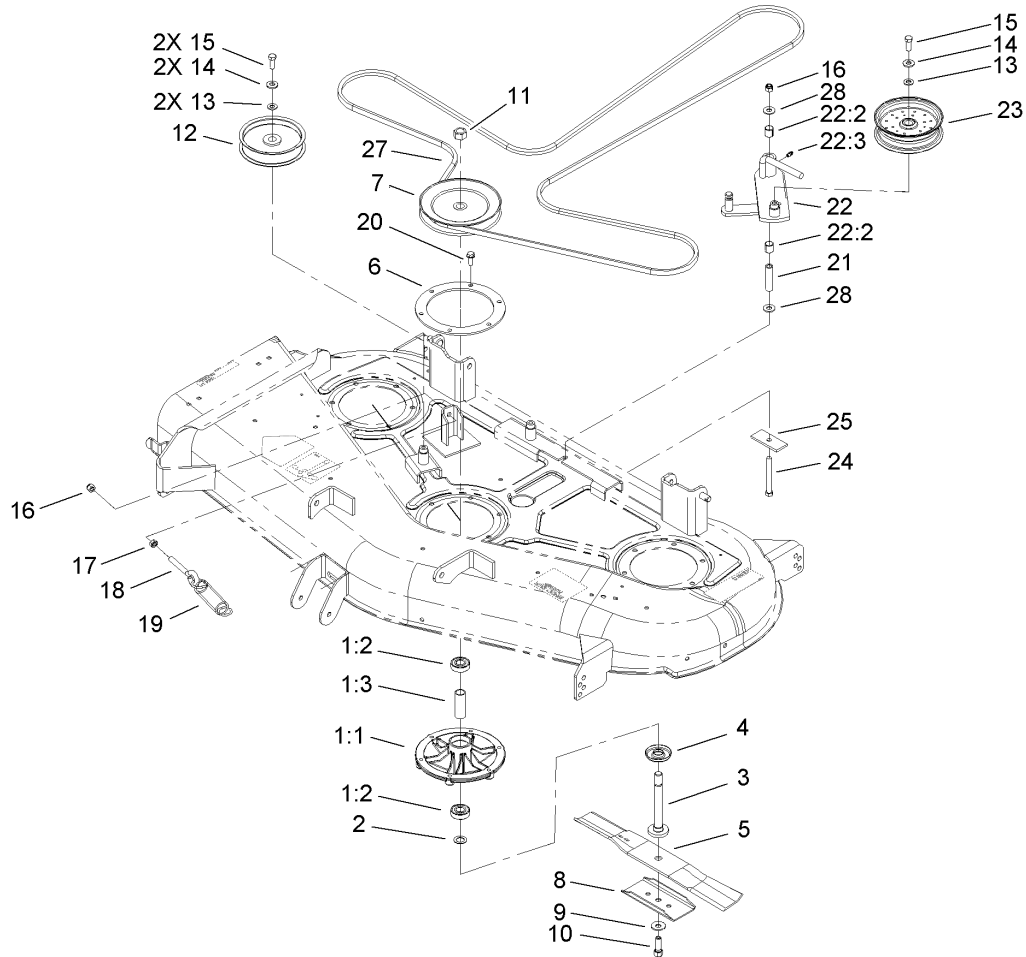

52in Deck Belt Drive Assembly

Ref	Part No.	Qty.	Description
1	2	3	Spindle ASM
1:1	107-1739	1	Housing-Spindle
1:2	100-1048	2	Bearing-Ball
1:3	62-3661	1	Spacer-Bearing
2	80-4380	3	Spacer
3	80-4341	3	Shaft
4	80-4360	3	Shield-Bearing
5	107-1741-03	3	Blade
6	107-1743-03	3	Ring-Support, Deck
7	107-1740	3	Pulley And Hub ASM
8	80-0510-03	3	Stiffener-Blade
9	3290-465	3	Washer-Belleville
10	26-0671	3	Screw-Blade
11	3219-6	3	Nut-Hex
12	1-613098	2	Pulley-Idler
13	3256-24	3	Washer-Flat
14	98-5975	3	Washer-Belleville
15	323-6	3	Screw-HH
16	3296-39	2	Nut-Lock, NI
17	3217-7	1	Nut-Hex
18	94-2547	1	Bolt-Eye
19	105-6992	1	Spring-Extension
20	32144-41	18	Screw-Taptite
21	1-603384	1	Bushing-Pivot, Idler

Ref	Part No.	Qty.	Description
22	105-7010	1	Idler Arm ASM
22:2	1-513034	2	Sleeve-Bearing
22:3	302-5	1	Fitting-Grease
23	99-8912	1	Pulley-Idler, Flat
24	1-800805	1	Screw-HH
25	104-8037-03	1	Plate-Bolt, Retainer
27	106-2217	1	Belt-V
28	1-809107	2	Washer-Hardened

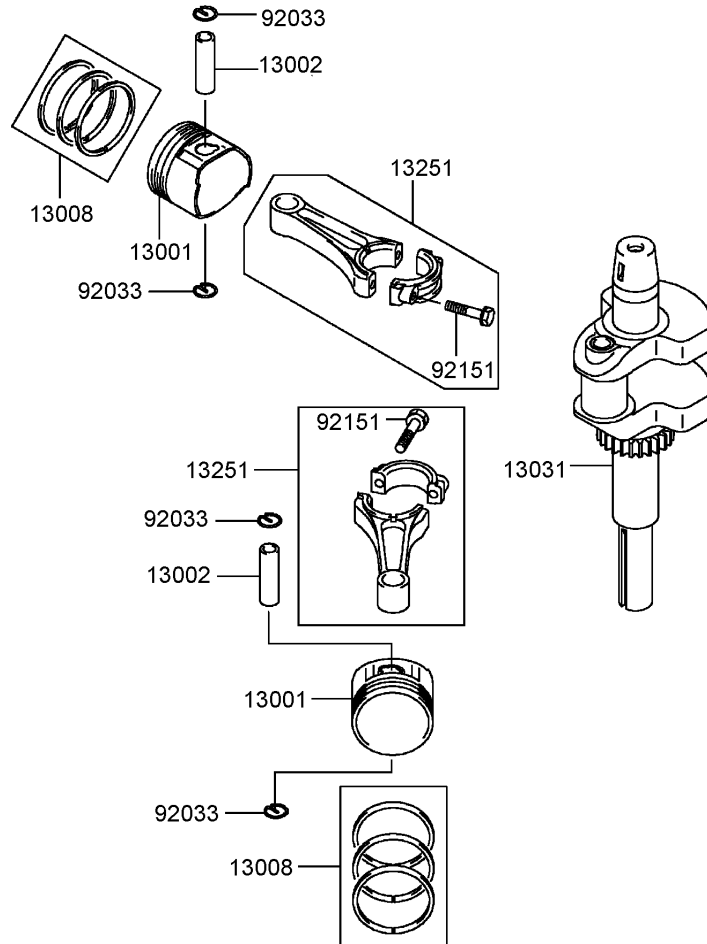

Piston and Crankshaft Assembly Kawasaki FH580V-CS13-R

Ref	Part No.	Qty.	Description				
①13001	13001-7010	2	Piston-Engine				
①13002	13002-7001	2	Pin-Piston				
①13008	13008-6060	2	Ring Set-Piston				
①13031	13031-7036	1	Crankshaft				
①13251	13251-7010	2	Connecting Rod ASM				
①92033	92033-7005	4	Ring-Snap				
①92151	92151-7017	4	Bolt (6X35)				

Valve and Camshaft Assembly Kawasaki FH580V-CS13-R

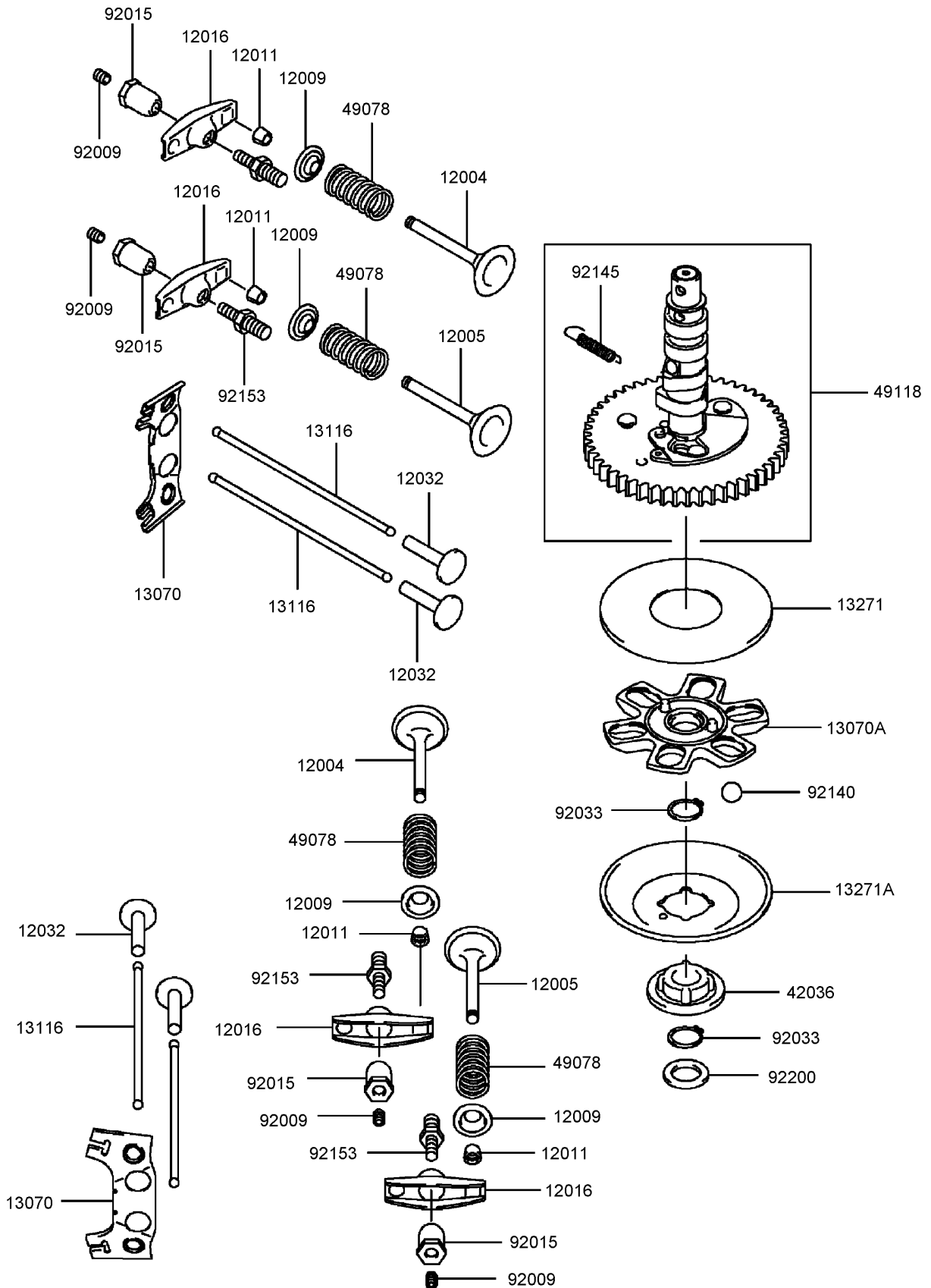

Valve and Camshaft Assembly Kawasaki FH580V-CS13-R

Ref	Part No.	Qty.	Description				
⑤12004	12004-7003	2	Valve-Intake				
⑤12005	12005-7003	2	Valve-Exhaust				
⑤12009	12009-7001	4	Retainer-Spring, Valve				
⑤12011	12011-2056	8	Collet				
⑤12016	12016-7008	4	Arm-Rocker				
⑤12032	12032-7001	4	Tappet				
⑤13070	13070-7001	2	Guide				
⑤13070A	13070-7004	1	Guide				
⑤13116	13116-2057	4	Rod-Push				
⑤13271	13271-7007	1	Plate				
⑤13271A	13271-7021	1	Plate-Governor				
⑤42036	42036-7010	1	Sleeve				
⑤49078	49078-7001	4	Spring-Valve, Engine				
⑤49118	49118-7004	1	Camshaft				
⑤92009	92009-2341	4	Screw				
⑤92015	92015-2253	4	Nut				
⑤92033	92033-7001	2	Ring-Snap				
⑤92140	92140-7002	6	Ball				
⑤92145	92145-7001	1	Spring				
⑤92153	92153-7019	4	Bolt				
⑤92200	92200-7001	1	Washer				

Lubrication Equipment Assembly Kawasaki FH580V-CS13-R

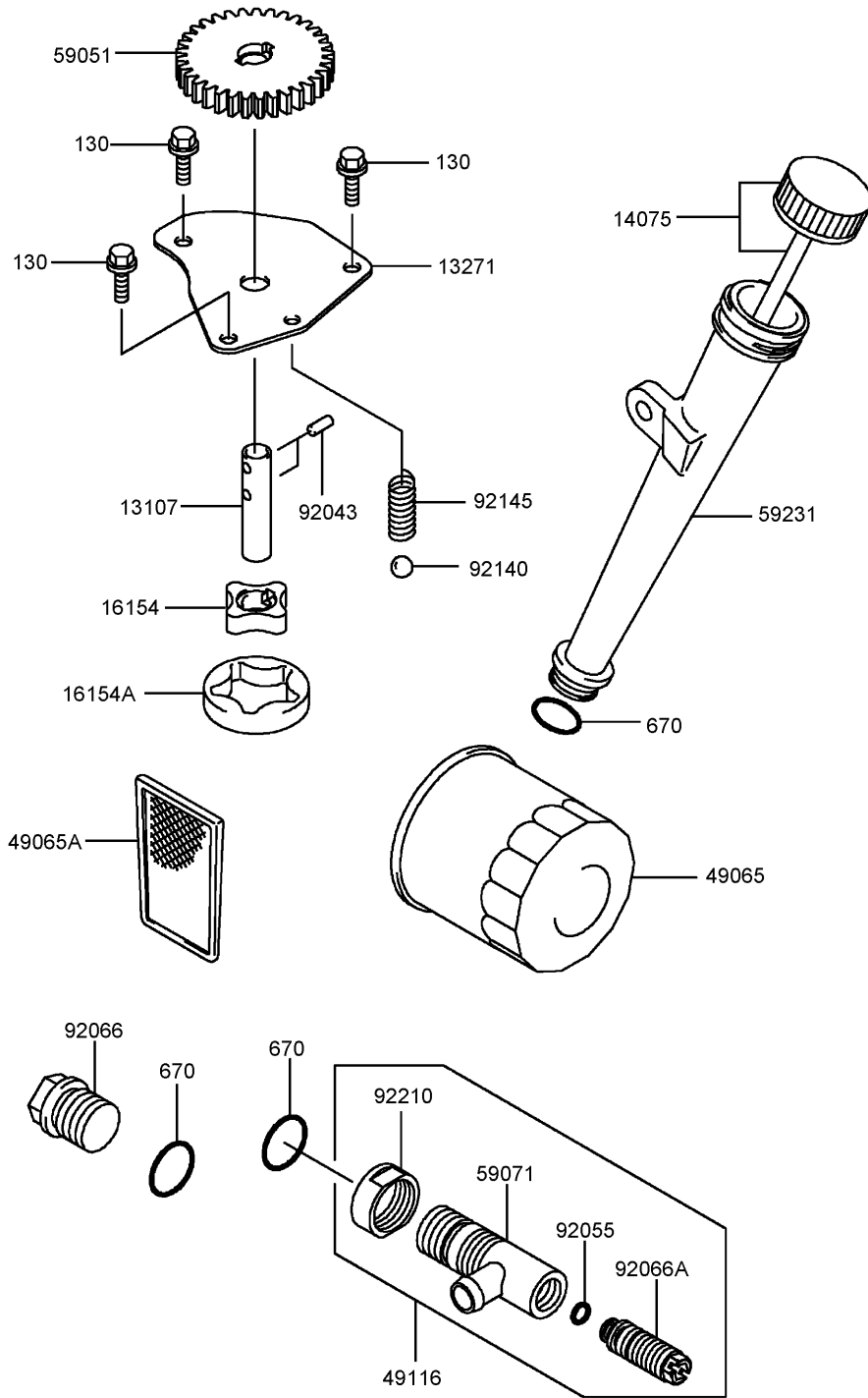

Lubrication Equipment Assembly Kawasaki FH580V-CS13-R

Ref	Part No.	Qty.	Description				
③13107	13107-7009	1	Shaft				
③13271	13271-7017	1	Plate				
③14075	14075-7009	1	Cap ASM				
③16154	16154-2053	1	Rotor-Pump (In)				
③16154A	16154-2054	1	Rotor-Pump (Out)				
③49065	49065-2078	1	Filter-Oil				
③49065A	49065-7004	1	Filter-Oil				
③49116	49116-7001	1	Valve ASM				
③59051	59051-7011	1	Gear-Spur				
③59071	59071-7008	1	Joint				
③59231	59231-7005	1	Filler				
③92043	92043-7003	2	Pin				
③92055	92055-7002	1	O-Ring (6Mm)				
③92066	92066-7003	1	Plug				
③92066A	92066-7007	1	Plug				
③92140	92140-7003	1	Ball				
③92145	92145-7002	1	Spring				
③92210	92210-7012	1	Nut				
③130	130B0612	3	Bolt-Flanged (6X12)				
③670	670D2016	3	O-Ring (16Mm)				

Electrical Equipment Assembly Kawasaki FH580V-CS13-R

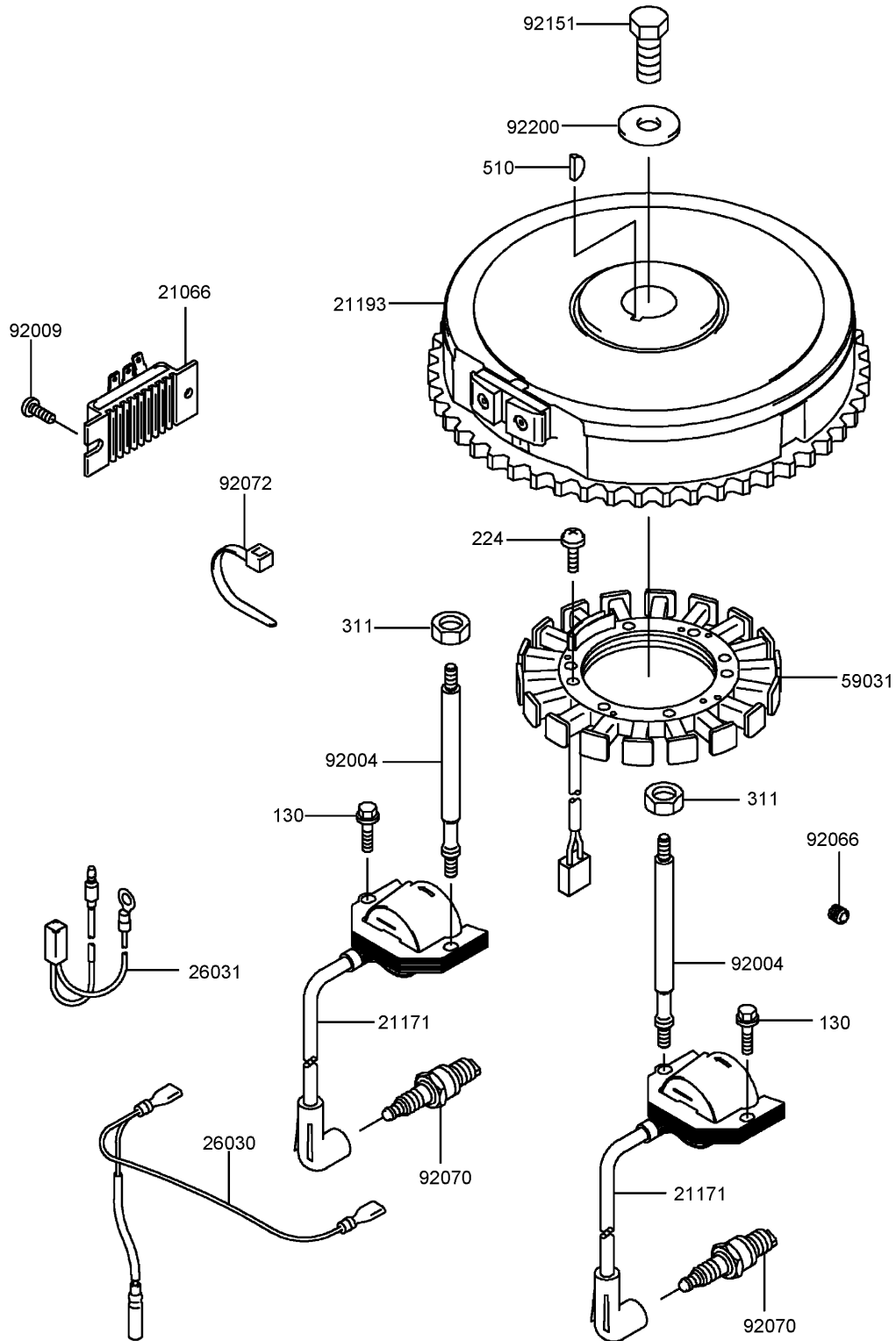

Electrical Equipment Assembly Kawasaki FH580V-CS13-R

Ref	Part No.	Qty.	Description				
③21066	21066-7011	1	Regulator-Voltage				
③21171	21171-7013	2	Ignition Coil ASM				
③21193	21193-7007	1	Flywheel ASM				
③26030	26030-7001	1	Harness				
③26031	26031-7012	1	Harness				
③59031	59031-7009	1	Coil-Charging				
③92004	92004-7009	2	Stud				
③92009	92009-2308	1	Screw				
③92066	92066-7002	1	Plug				
③92070	92070-7003	2	Plug-Spark (R C J 8 Y, Solid)				
③92072	92072-7003	2	Band				
③92151	92151-2097	1	Bolt (12X30)				
③92200	92200-7002	1	Washer				
③130	130B0620	2	Bolt-Flanged (6X20)				
③224	224B0520	4	Screw-Pan (5X20)				
③311	311B0600	2	Nut-Hex (6Mm)				
③510	510A5100	1	Key-Woodruff				

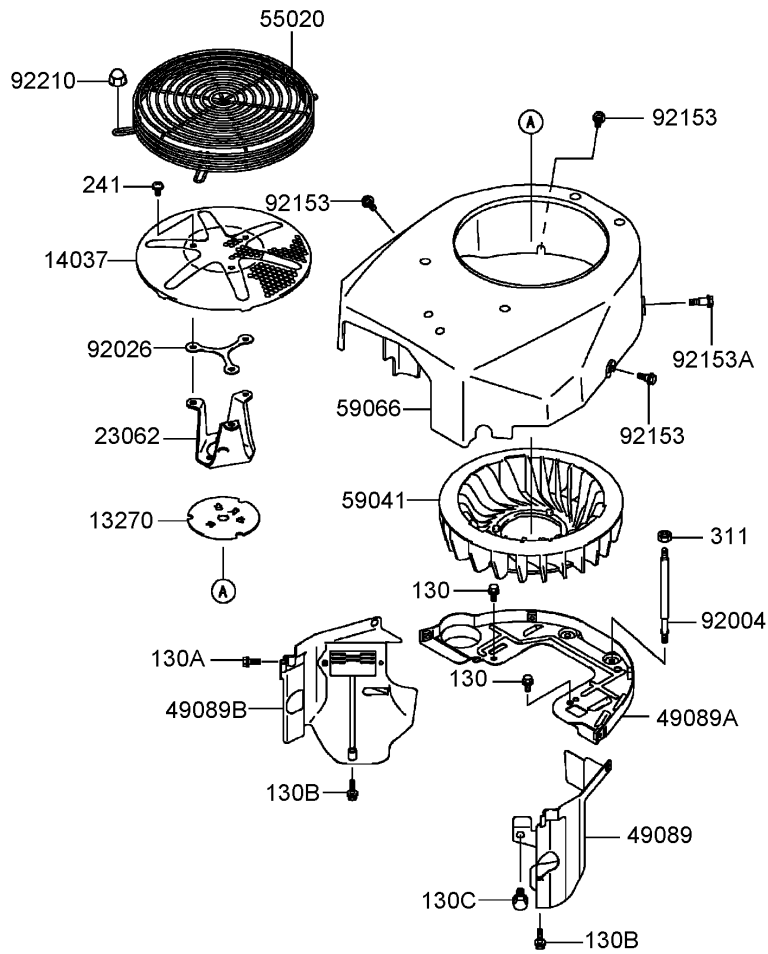

Cooling Equipment Assembly Kawasaki FH580V-CS13-R

Ref	Part No.	Qty.	Description
● 13270	13270-7007	1	Plate
● 14037	14037-7020-9H	1	Screen
● 23062	23062-7010	1	Bracket
● 49089	49089-7002	1	Shroud-Engine
● 49089A	49089-7032	1	Shroud-Engine
● 49089B	49089-7034	1	Shroud-Engine
● 55020	55020-7004	1	Guard
● 59041	59041-7010	1	Fan
● 59066	59066-7002	1	Housing-Fan
● 92004	92004-7006	2	Stud
● 92026	92026-7007	1	Spacer
● 92153	92153-7007	3	Bolt
● 92153A	92153-7008	1	Bolt
● 92210	92210-0003	4	Nut
● 130	130B0612	2	Bolt-Flanged (6X12)
● 130A	130B0616	2	Bolt-Flanged (6X16)
● 130B	130B0625	2	Bolt-Flanged (6X25)
● 130C	130B0816	1	Bolt-Flanged (8X16)
● 241	241B0612	3	Bolt-Flanged
● 311	311B0600	2	Nut-Hex (6Mm)

--	--	--	--

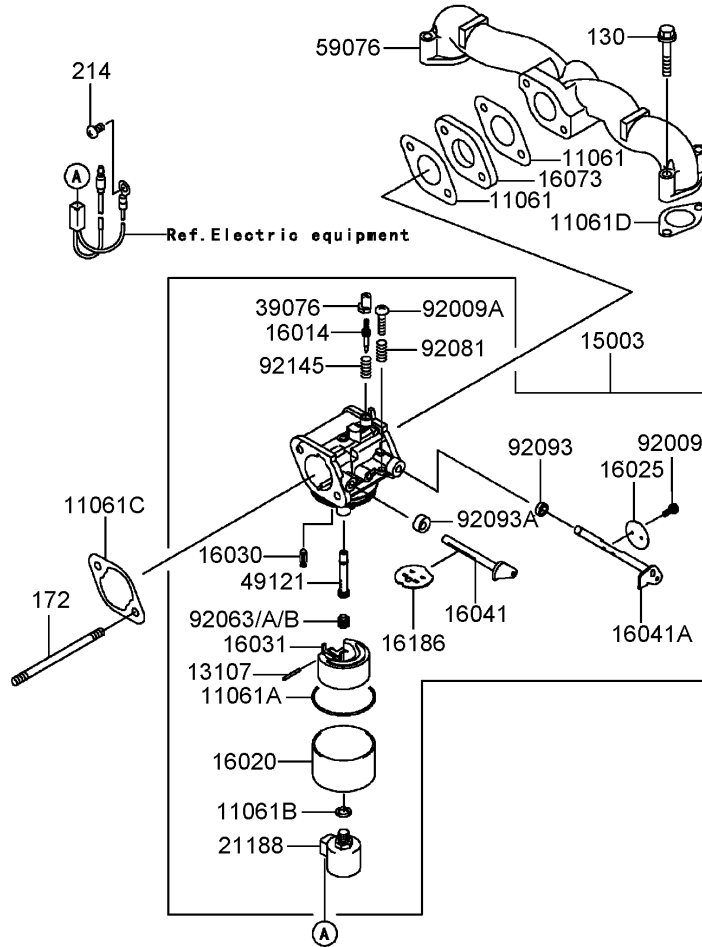

Carburetor Assembly Kawasaki FH580V-CS13-R

Ref	Part No.	Qty.	Description
①11061	11061-7004	2	Gasket-Insulator
①11061A	11061-7009	1	Gasket-Chamber
①11061B	11061-7010	1	Gasket-Screw
①11061C	11061-7018	1	Gasket-Cleaner, Air
①11061D	11061-7019	2	Gasket
①13107	13107-7018	1	Shaft
①15003	15003-7081	1	Carburetor ASM
①16014	16014-7004	1	Screw-Air, Pilot
①16020	16020-7003	1	Chamber-Float
①16025	16025-7006	1	Valve-Throttle
①16030	16030-7003	1	Valve-Float
①16031	16031-7002	1	Float
①16041	16041-7016	1	Shaft-Choke, Carburetor
①16041A	16041-7018	1	Shaft-Throttle, Carburetor
①16073	16073-7007	1	Insulator
①16186	16186-7004	1	Choke Valve ASM
①21188	21188-7002	1	Solenoid
①39076	39076-7001	1	Limiter
①49121	49121-7004	1	Nozzle-Main
①59076	59076-7001	1	Manifold-Intake
①92009	92009-2083	2	Screw
①92009A	92009-2349	1	Screw
①92063	92063-7037	1	Jet-Main (No. 105)
①92063A	92063-7046	1	Jet-Main (No. 100)

Ref	Part No.	Qty.	Description
①92063B	92063-7047	1	Jet-Main (No. 098, 3280 Ft)
①92081	92081-2234	1	Spring
①92093	92093-2100	1	Seal
①92093A	92093-7003	1	Seal
①92145	92145-7015	1	Spring
①130	130B0635	4	Bolt-Flanged (6X35)
①172	172G0685	2	Bolt-Stud
①214	214B0510	1	Screw-Pan (5X10)

Control Equipment Assembly Kawasaki FH580V-CS13-R

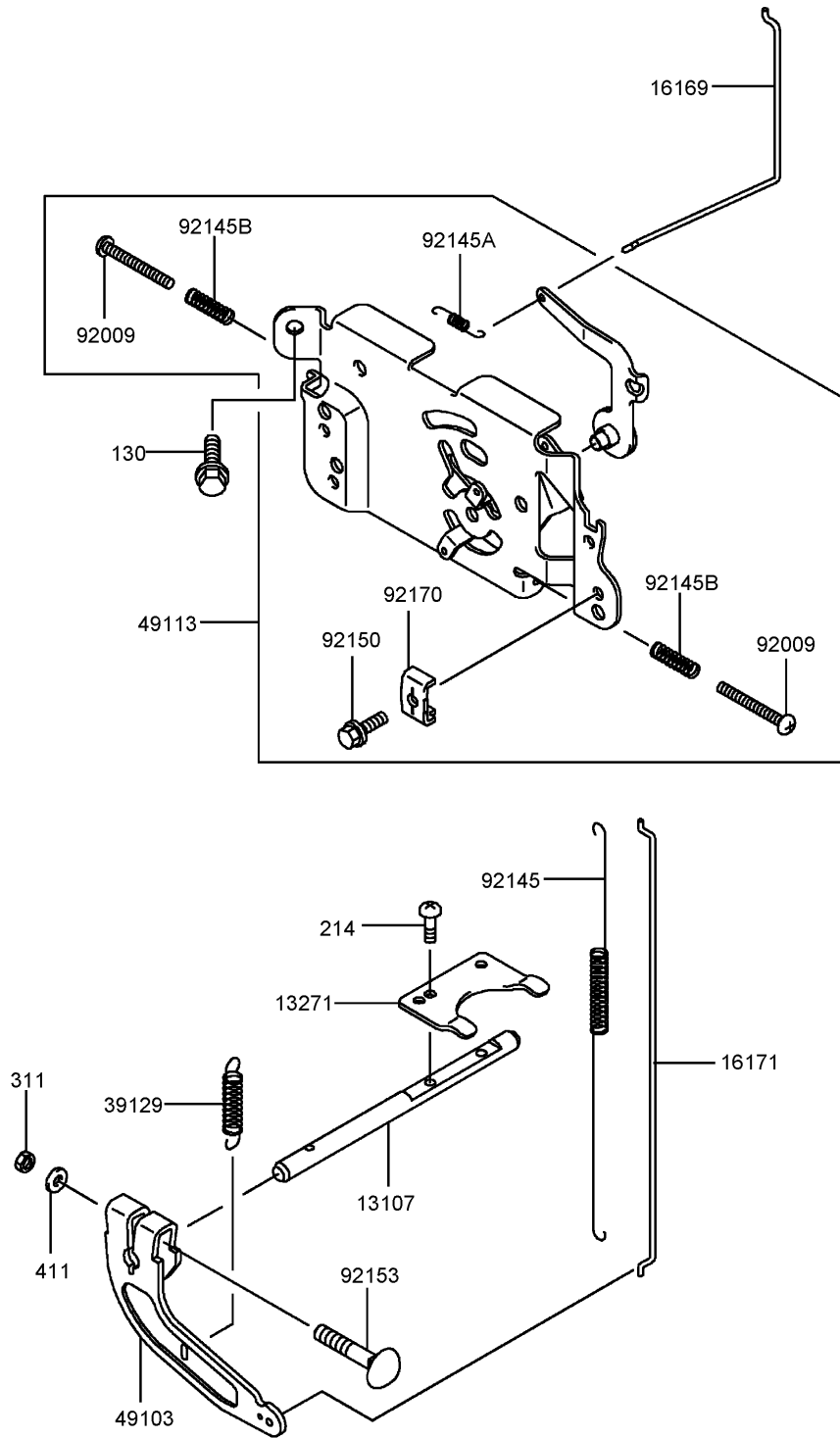

Control Equipment Assembly Kawasaki FH580V-CS13-R

Ref	Part No.	Qty.	Description				
③13107	13107-7010	1	Shaft				
③13271	13271-7032	1	Plate				
③16169	16169-7010	1	Link-Choke				
③16171	16171-7001	1	Link				
③39129	39129-7003	1	Spring-Governor				
③49103	49103-7004	1	Arm-Governor				
③49113	49113-7027	1	Panel-Control				
③92009	92009-7007	2	Screw (4X35)				
③92145	92145-7003	1	Spring				
③92145A	92145-7004	1	Spring				
③92145B	92145-7005	2	Spring				
③92150	92150-2182	1	Bolt (5X18)				
③92153	92153-7033	1	Bolt (6X35)				
③92170	92170-7001	1	Clamp				
③130	130B0612	2	Bolt-Flanged (6X12)				
③214	214B0408	2	Screw-Pan (4X8)				
③311	311B0600	1	Nut-Hex (6Mm)				
③411	411B0600	1	Washer-Plain (6Mm)				

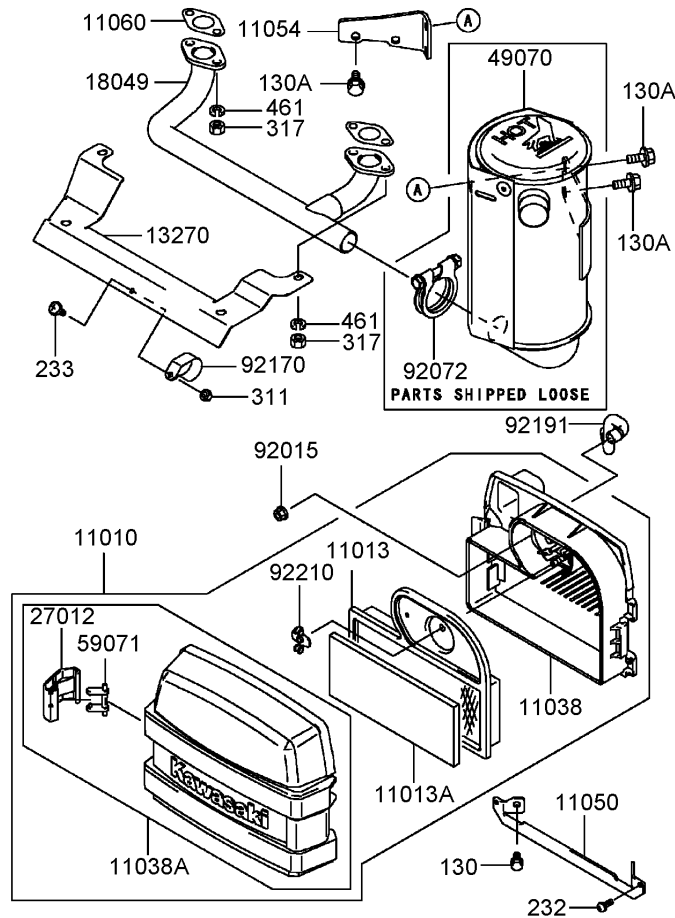

Air Filter and Muffler Assembly Kawasaki FH580V-CS13-R

Ref	Part No.	Qty.	Description
③11010	11010-7013	1	Air Filter ASM
③11013	11013-7002	1	Element-Filter, Air
③11013A	11013-7033	1	Element-Filter, Air
③11038	11038-7006	1	Air Filter Case ASM
③11038A	11038-7013	1	Air Filter Case ASM
③11050	11050-7006	1	Bracket
③11054	11054-7002-9H	1	Bracket
③11060	11060-7021	2	Gasket-Muffler
③13270	13270-7008	1	Plate
③18049	18049-7001	1	Pipe-Exhaust
③27012	27012-7003	2	Hook
③49070	49070-7021	1	Muffler
③59071	59071-7017	2	Joint
③92015	92015-1193	2	Nut
③92072	92072-7012	1	Band
③92170	92170-7002	1	Clamp
③92191	92191-7001	1	Tube
③92210	92210-7004	1	Nut
③130	130B0612	2	Bolt-Flanged (6X12)
③130A	130B0816	3	Bolt-Flanged (8X16)
③232	232B0514	2	Screw-Pan
③233	233B0416	1	Screw (4X16)
③311	311B0400	1	Nut-Hex (4Mm)

Ref	Part No.	Qty.	Description
③317	317R0800	4	Nut-Hex, Small (8Mm)
③461	461F0800	4	Washer-Spring (8Mm)

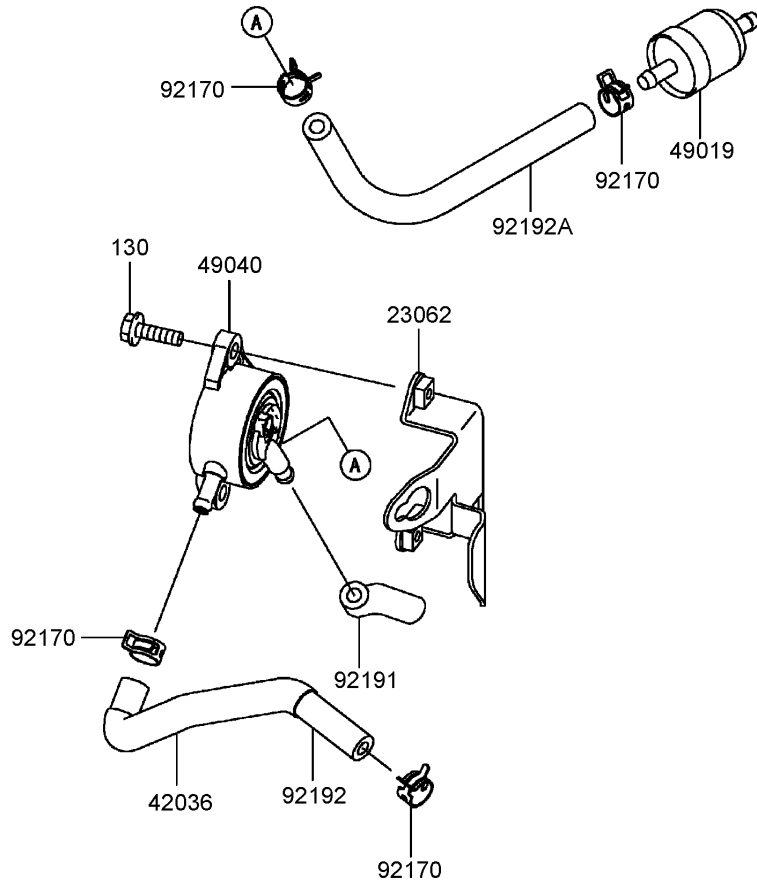

Fuel Tank and Fuel Valve Assembly Kawasaki FH580V-CS13-R

Ref	Part No.	Qty.	Description				
③23062	23062-7004-9H	1	Bracket				
③42036	42036-7012	1	Sleeve				
③49019	49019-7001	1	Filter-Fuel				
③49040	49040-7001	1	Pump-Fuel				
③92170	92170-2009	4	Clamp				
③92191	92191-7002	1	Tube				
③92192	92192-7051	1	Tube				
③92192A	92192-7055	1	Tube				
③130	130B0620	2	Bolt-Flanged (6X20)				

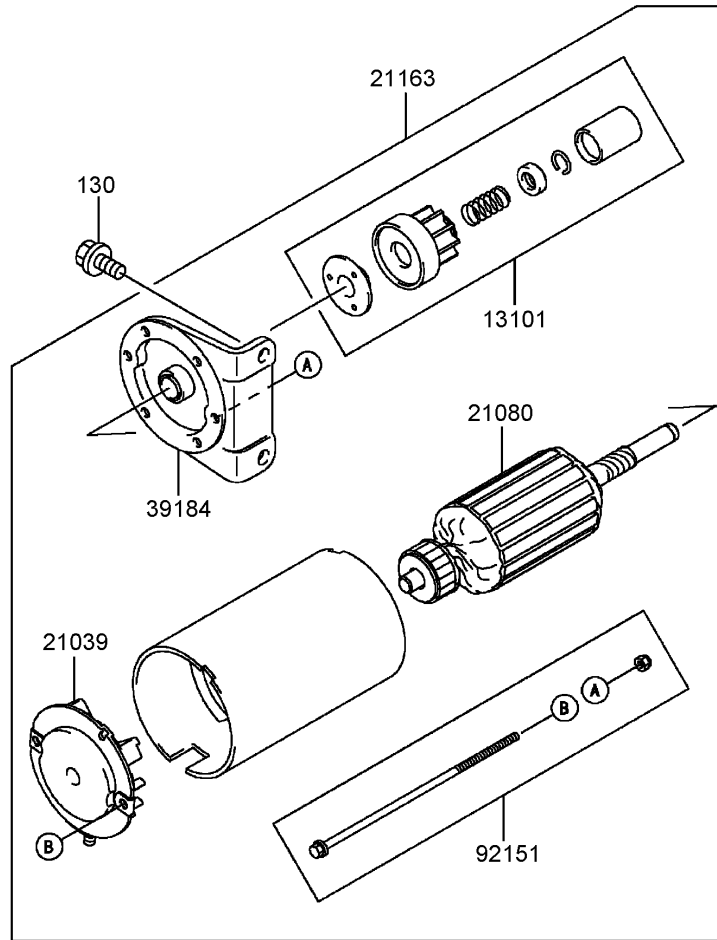

Starter Assembly Kawasaki FH580V-CS13-R

Ref	Part No.	Qty.	Description
● 13101	13101-7003	1	Gear ASM
● 21039	21039-7004	1	Brush
● 21080	21080-7001	1	Armature
● 21163	21163-7010	1	Starter-Electric
● 39184	39184-7004	1	Bracket ASM
● 92151	92151-7013	1	Bolt
● 130	130B0816	2	Bolt-Flanged (8X16)

Attachments and Accessories

For 74806 - TimeCutter ZX525 Riding Mower

Product Name	Model/Part
Light Kit	104-8041
Tire Chain Kit	105-1851
Smooth Caster Wheel Kit	105-1856
French Decal Kit	110-6507
56 Inch Snow Blade	79165
52 Inch Recycler Kit	79186

NOTES

NOTES

NOTES

