



Transport Frame and Ramp Kits Trans Pro 80 Tow-Behind Trailer

Model No. 04238 - 270001501 and up.

Model No. 04244

Model No. 04245

Parts Catalog

Ordering Replacement Parts

To order replacement parts, please supply the part number, the quantity, and the description of each part desired.

Understanding Reference Numbers

Each Identified part in an illustration has a reference number. The reference number for a part also appears in the parts list, along with other information about the part.

This catalog uses two special reference number formats, one to indicate parts in a service assembly and another to indicate the quantity of a given part in an illustration.

Service Assembly Reference Numbers

Parts in service assemblies have reference numbers in the form a:b. The a represents the reference number of the entire service assembly and the b represents a sequential number unique to each part within the service assembly.

For example, a wheel assembly might be identified by reference number 6, the tire by 6:1, the valve by 6:2, and the wheel by 6:3. When you order the assembly identified by reference number 6, you receive all parts identified by reference numbers 6:1, 6:2, and 6:3. However, you may also order any part individually. Reference numbers of this type appear in illustrations and in part lists.

Reference Numbers Indicating Quantity

In an illustration, if a reference number indicates more than one part, the reference number has the form nX y. The n represents the quantity of the part, the X is the multiplication symbol, and the y represents the reference number.

For example, in an illustration, the reference number 2X 37 means that two of the parts identified by reference number 37 are indicated.

Contents

Description	Page	Description	Page
Main Trailer Assembly 3	Rail Ramp Assembly 6
Tongue Assembly 4	Flat Ramp Assembly 7
Hub and Wheel Assembly 5	Attachments and Accessories List 8

Part Description Abbreviations

Part descriptions in this catalog may include the following abbreviations.

AR. as required	HYD. hydraulic
ASM. assembly	LH. left hand
BBC. blade brake clutch	NI. nylon insert
CARR. carriage	NPTF. national pipe thread fine
DEG. degrees	PFH. phillips flat head
EXT. external	PPH. phillips pan head
FH. flat head	PPHTF. phillips pan head thread forming
GA. gauge	PRH. phillips round head
HD. heavy-duty	PTH. phillips truss head
HF. hex flange	PTO. power-take-off
HH. hex head	RH. right hand
HHF. hex head flange	ROPS. roll-over protection system
HHFTF. hex head flange thread forming	SFH. slotted fillister head
HJ. hex jam	SHH. slotted hex head
HLH. hex lag head	SHWH. slotted hex washer head
HOC. height-of-cut	SPH. slotted pan head
HSBH. hex socket button head	SQH. square head
HSFH. hex socket flat head	SRH. slotted round head
HSH. hex socket head	STD. standard
HWH. hex washer head	TAP. self tapping
HWHTF. hex washer head thread forming	TTH. torx truss head

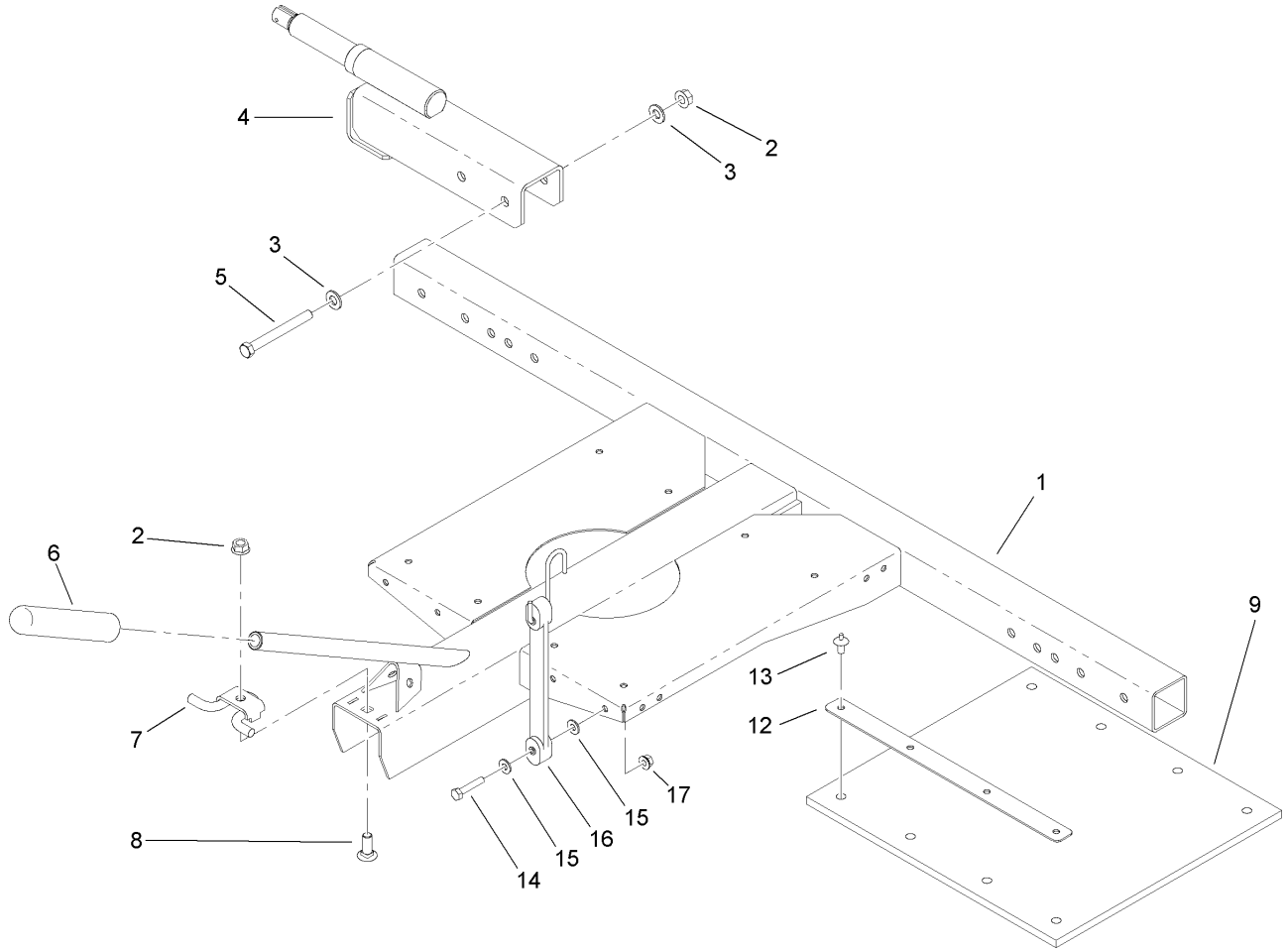

Main Trailer Assembly

Ref	Part No.	Qty.	Description
1	106-5366-01	1	Frame ASM
2	32128-21	5	Nut-HF
3	3256-24	8	Washer-Flat
4	112-9468-01	2	Axle ASM
5	323-15	4	Screw-HH
6	105-1904	1	Grip-Handle
7	108-6094	1	Latch
8	3231-22	1	Screw-CARR
9	106-5360	1	Mat-Roller
12	106-5384	2	Strip-Pad
13	105-9626	8	Rivet-Drive
14	321-13	2	Screw-HH
15	3256-22	4	Washer-Flat
16	106-8459	2	Bungee
17	32128-32	2	Nut-HHF

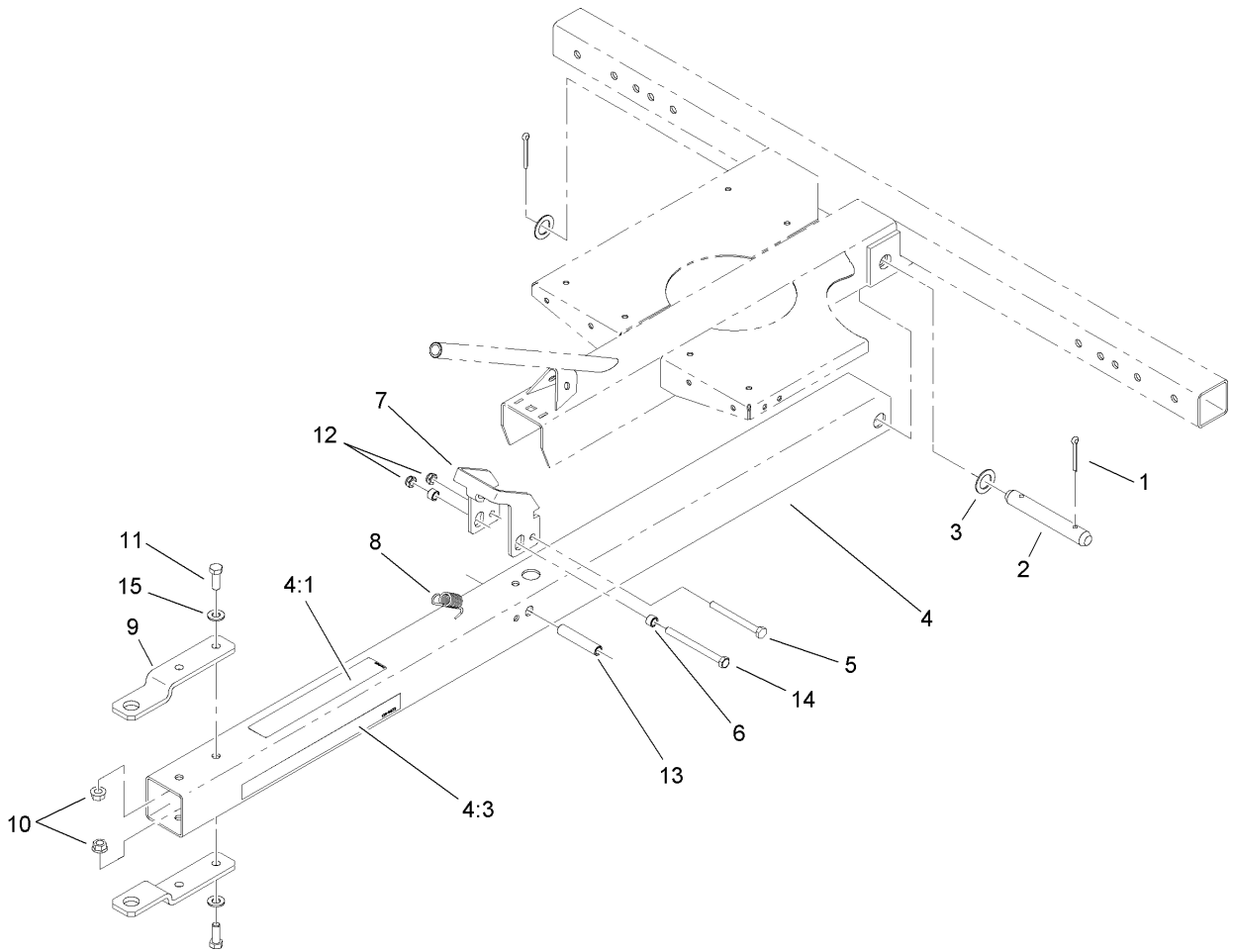

Tongue Assembly

Ref	Part No.	Qty.	Description
1	3272-23	2	Pin-Cotter
2	92-1233	1	Pin-Clevis
3	67-9410	2	Washer
4	106-4675	1	Tongue ASM
4:1	106-4669	1	Decal-Warning, Trailer
4:3	106-4673	2	Decal
5	322-20	1	Screw-HH
6	65-7910	2	Spacer
7	106-8437	1	Strap-Latch
8	105-9926	1	Spring-Extension
9	105-9930-01	2	Hitch
10	32128-21	4	Nut-HF
11	323-6	4	Screw-HH
12	3296-47	2	Nut-Lock, NI
13	105-9912	1	Spacer-Latch
14	322-23	1	Screw-HH
15	3256-24	4	Washer-Flat

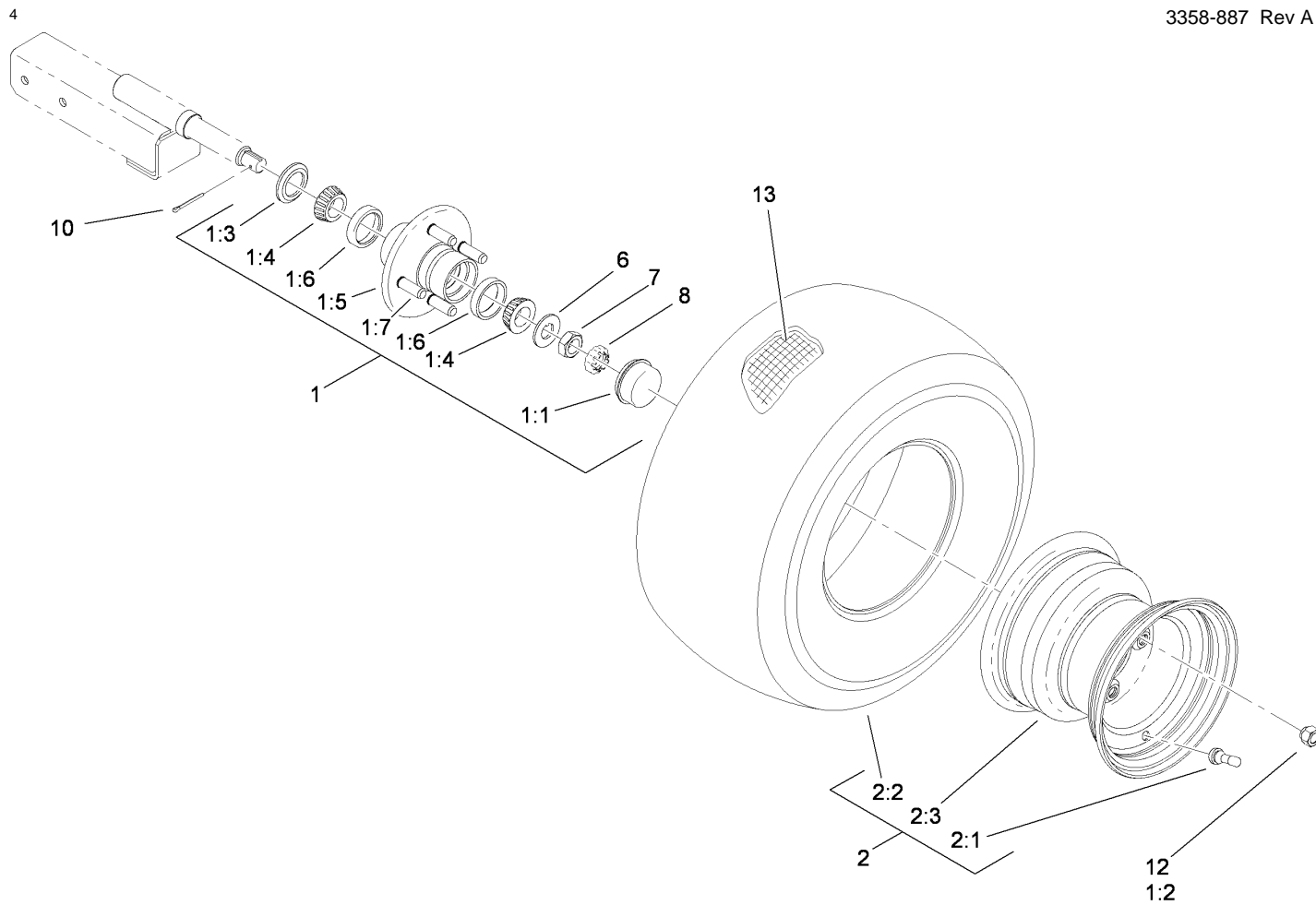

Hub and Wheel Assembly

Ref	Part No.	Qty.	Description
1	80-6570	2	Hub ASM
1:1	241-119	1	Cap-Dust
1:2	242-50	4	Nut-Lug
1:3	253-129	1	Seal
1:4	254-94	2	Bearing-Cone, Tapered
1:5	80-6580	1	Hub
1:6	254-72	2	Bearing-Cup, Tapered
1:7	10-6830	4	Stud-Type, Drive
2	98-8691	2	Wheel ASM
2:1	232-27	1	Stem-Valve
2:2	99-4506	1	Tire
2:3	99-4507	1	Rim
6	93-0309	2	Washer-Tab
7	3220-7	2	Nut-Jam
8	93-0307	2	Nut-Lock, Retainer
10	3272-13	2	Pin-Cotter
12	242-50	8	Nut-Lug
13	232-37	2	Tube

Ref	Part No.	Qty.	Description

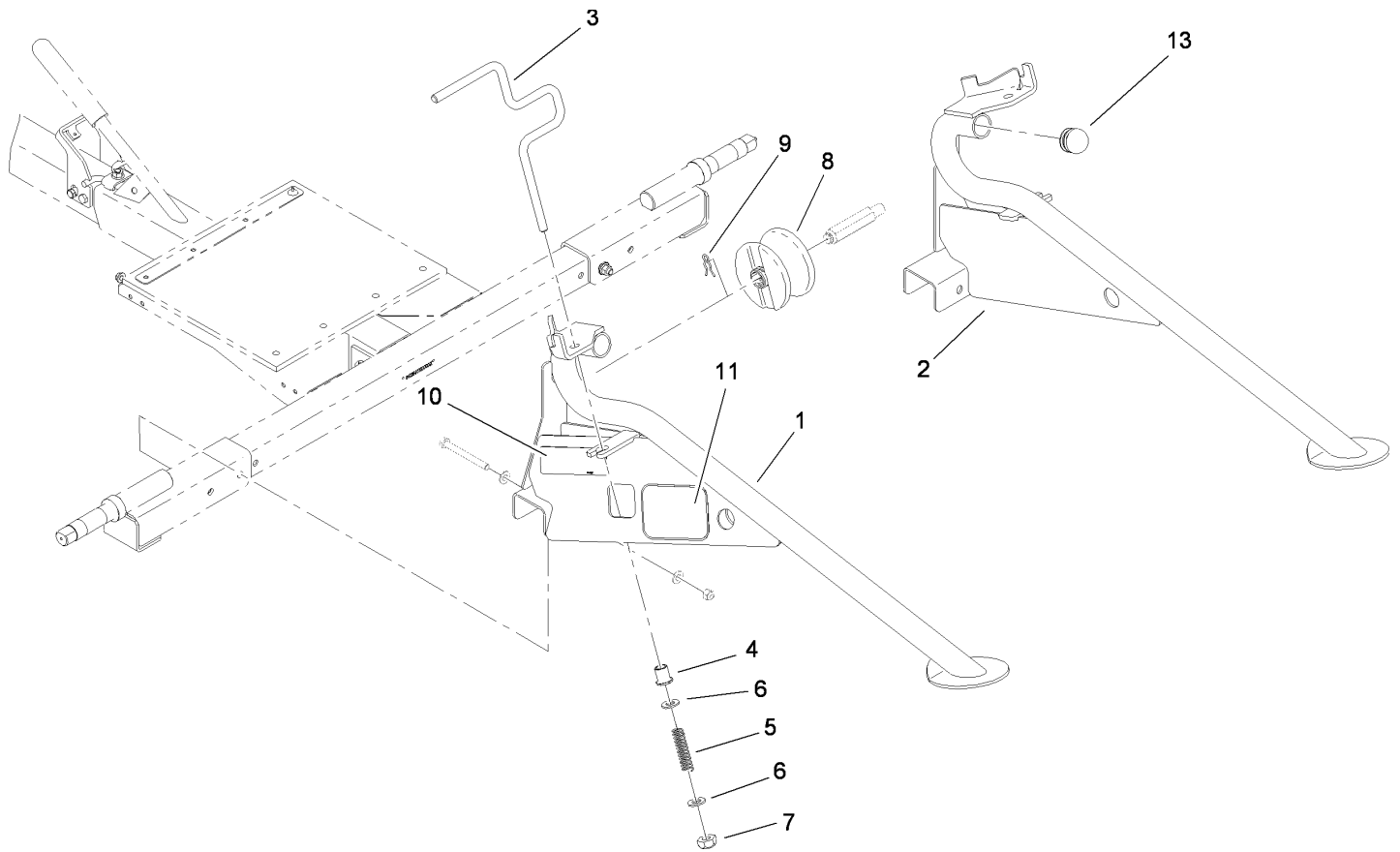

Rail Ramp Assembly

Ref	Part No.	Qty.	Description
1	110-3467-01	1	LH Rail ASM
2	110-3468-01	1	RH Rail ASM
3	106-5388	2	Rod-Lock
4	115-1061	2	Bushing-Flange
5	95-4256	2	Spring-Compression
6	3256-26	4	Washer-Flat
7	32146-13	2	Nut-Lock
8	106-5353	2	Wheel ASM
9	99-6204	2	Clip-Retaining
10	98-8687	2	Decal-Pressure, Air
11	67-1300	2	Decal
13	110-3469	2	Plug-Head, Ball

--	--	--	--

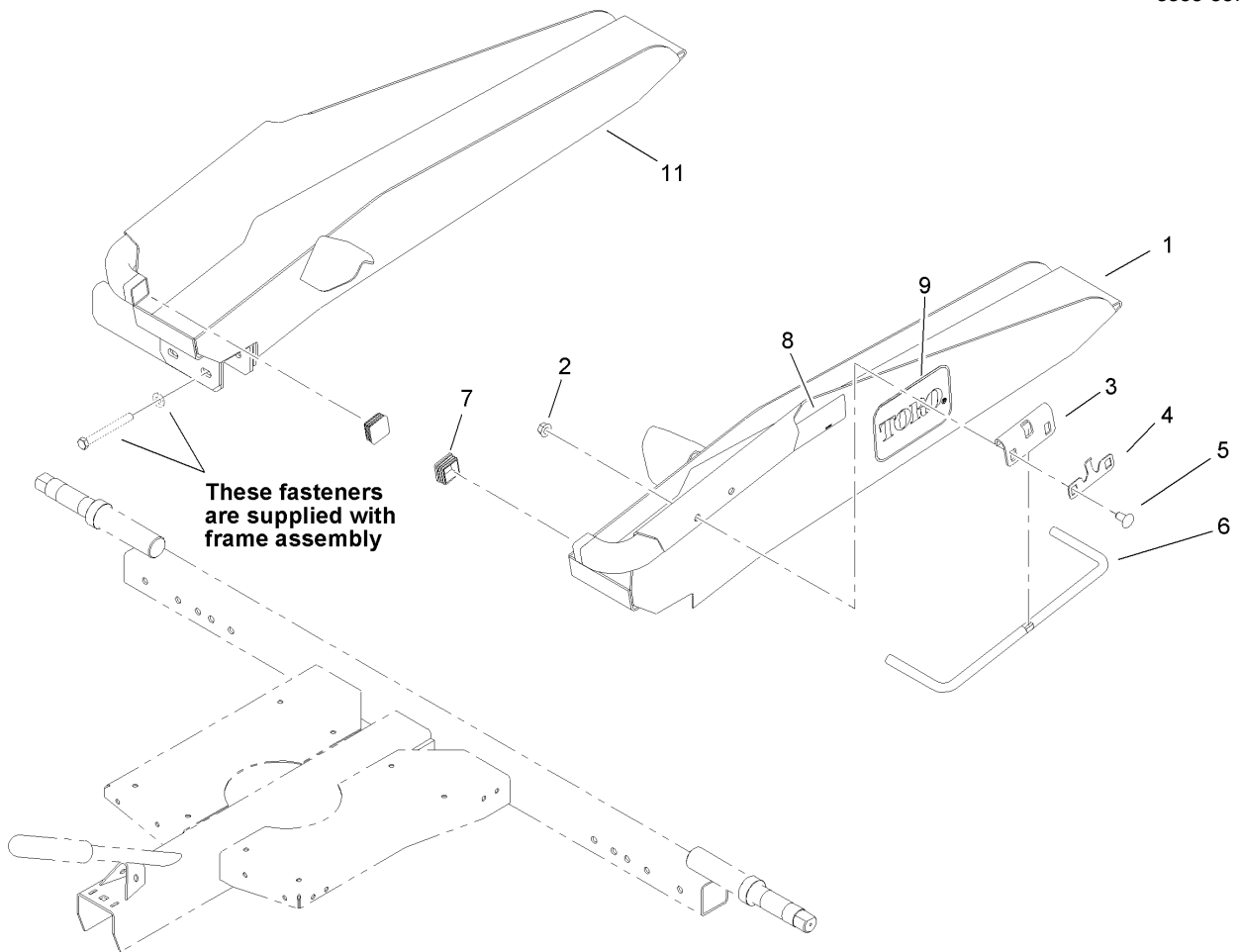

Flat Ramp Assembly

Ref	Part No.	Qty.	Description
1	107-8183-01	1	LH Ramp ASM
2	32128-21	4	Nut-HF
3	108-3156	2	Bracket-Rod
4	106-5354	2	Spring-Latch
5	3231-21	4	Screw-CARR
6	105-5394	2	Rod-Trailer, Large
7	105-9935	2	Plug-Tube, Square
8	98-8687	2	Decal-Pressure, Air
9	68-3640	2	Decal
11	107-8184-01	1	RH Ramp ASM

--	--	--	--

Attachments and Accessories

For 04238 - Transport Frame, Trans Pro 80 Tow-Behind Trailer

Product Name	Model/Part
Rail Ramp	04244
Flat Ramp	04245
Adjustable Hitch Kit	107-8188

NOTES

NOTES

NOTES

