



Multi-Pro[®] 1200 Turf Sprayer

Model No. 41178 - 280000001 and up.

Parts Catalog

Ordering Replacement Parts

To order replacement parts, please supply the part number, the quantity, and the description of each part desired.

Understanding Reference Numbers

Each identified part in an illustration has a reference number. The reference number for a part also appears in the parts list, along with other information about the part.

This catalog uses two special reference number formats, one to indicate parts in a service assembly and another to indicate the quantity of a given part in an illustration.

Service Assembly Reference Numbers

Parts in service assemblies have reference numbers in the form a:b. The a represents the reference number of the entire service assembly and the b represents a sequential number unique to each part within the service assembly.

For example, a wheel assembly might be identified by reference number 6, the tire by 6:1, the valve by 6:2, and the wheel by 6:3. When you order the assembly identified by reference number 6, you receive all parts identified by reference numbers 6:1, 6:2, and 6:3. However, you may also order any part individually. Reference numbers of this type appear in illustrations and in part lists.

Reference Numbers Indicating Quantity

In an illustration, if a reference number indicates more than one part, the reference number has the form nX y. The n represents the quantity of the part, the X is the multiplication symbol, and the y represents the reference number.

For example, in an illustration, the reference number 2X 37 means that two of the parts identified by reference number 37 are indicated.

Contents

Description	Page	Description	Page
Front Suspension Assembly 4	Tank and Saddle Assembly 38
Hydraulic Cylinder Assembly No. 100-8278 5	Throttle Linkage Assembly 39
Engine Cover Assembly 6	Exhaust Assembly 40
Seat Support Assembly 8	Electrical Panel Assembly 41
Brake and Accelerator Pedal Assembly 9	Manual Control Assembly 42
Master Cylinder Assembly No. 94-3800 10	Main On/Off Valve Assembly No. 106-4881 43
Rear Fender and Battery Mount Assembly 11	Pressure Control Valve Assembly 44
Fresh Water Tank Assembly 12	Boom Valve Assembly No. 106-4882 45
Main Tank Assembly 13	Flow Meter Assembly No. 106-4884 46
Lid Assembly 14	Hydraulic Hose Routing Assembly 47
Shifter Assembly 15	Steering Control Assembly No. 114-5076 48
Parking Brake and Console Assembly 16	Sprayer Component Assembly No. 1 49
Front Wheel Assembly 17	Pressure Damper Assembly No. 100-6662 50
Front Brake Assembly No. 100-8285 18	Sprayer Component Assembly No. 2 51
Transaxle Installation Assembly 19	Top Mounted Suction Assembly 52
Case Assembly Transaxle Assembly No. 104-9078 20	Sprayer Component Assembly No. 3 53
Gear Shaft Assembly Transaxle Assembly No. 104-9078 21	Safety Valve Assembly No. 100-6820 54
Countershaft Assembly Transaxle Assembly No. 104-9078 22	Hose Assemblies No. 1 55
Shift Fork Assembly Transaxle Assembly No. 104-9078 23	Hose Assemblies No. 2 56
Differential Gear Assembly Transaxle Assembly No. 104-9078 24	Boom Mount Assembly 58
Drive Shaft Assembly No. 100-8293 25	Center Boom Assembly 59
Rear Wheel and Brake Assembly 26	Left and Right Hand Boom Assembly 60
LH Rear Brake Assembly No. 112-7961 27	Right Hand Boom Mount Assembly 61
RH Rear Brake Assembly No. 112-7962 28	Left Hand Boom Mount Assembly 62
Driveshaft Assembly No. 98-2918 29	Crankshaft Assembly Kohler CH20S-64647 63
Engine and Gearbox Assembly 30	Crankcase Assembly Kohler CH20S-64647 64
Pump Drive Gearbox Assembly No. 108-3352 31	Oil Pan / Lubrication Assembly Kohler CH20S-64647 65
Drive Pulley Assembly No. 100-8289 32	Head / Valve / Breather Assembly Kohler CH20S-64647 66
Steering Pump Assembly No. 100-8302 33	Ignition / Electrical Assembly Kohler CH20S-64647 67
Driver Clutch Assembly No. 100-8288 34	Blower Housing and Baffle Assembly Kohler CH20S-64647 68
Pump Assembly 35	Starting System Kohler CH20S-64647 69
Pump Assembly No. 106-5121 36	Fuel System Assembly Kohler CH20S-64647 70
Hydraulic Brake Line Assembly 37	Engine Control Kohler CH20S-64647 71
		Air Intake / Filtration Assembly Kohler CH20S-64647 72
		Exhaust Assembly Kohler CH20S-64647 73

Part Description Abbreviations

Part descriptions in this catalog may include the following abbreviations.

AR.	as required	HYD.	hydraulic
ASM.	assembly	LH.	left hand
BBC.	blade brake clutch	NI.	nylon insert
CARR.	carriage	NPTF.	national pipe thread fine
DEG.	degrees	PFH.	phillips flat head
EXT.	external	PPH.	phillips pan head
FH.	flat head	PPHTF.	phillips pan head thread forming
GA.	gauge	PRH.	phillips round head
HD.	heavy-duty	PTH.	phillips truss head
HF.	hex flange	PTO.	power-take-off
HH.	hex head	RH.	right hand
HHF.	hex head flange	ROPS.	roll-over protection system
HHFTF.	hex head flange thread forming	SFH.	slotted fillister head
HJ.	hex jam	SHH.	slotted hex head
HLH.	hex lag head	SHWH.	slotted hex washer head
HOC.	height-of-cut	SPH.	slotted pan head
HSBH.	hex socket button head	SQH.	square head
HSFH.	hex socket flat head	SRH.	slotted round head
HSH.	hex socket head	STD.	standard
HWH.	hex washer head	TAP.	self tapping
HWHTF.	hex washer head thread forming	TTH.	torx truss head

Footnotes

- ❶ Not illustrated
- ❷ Not serviced separately
- ❸ Obtain Parts From Kohler

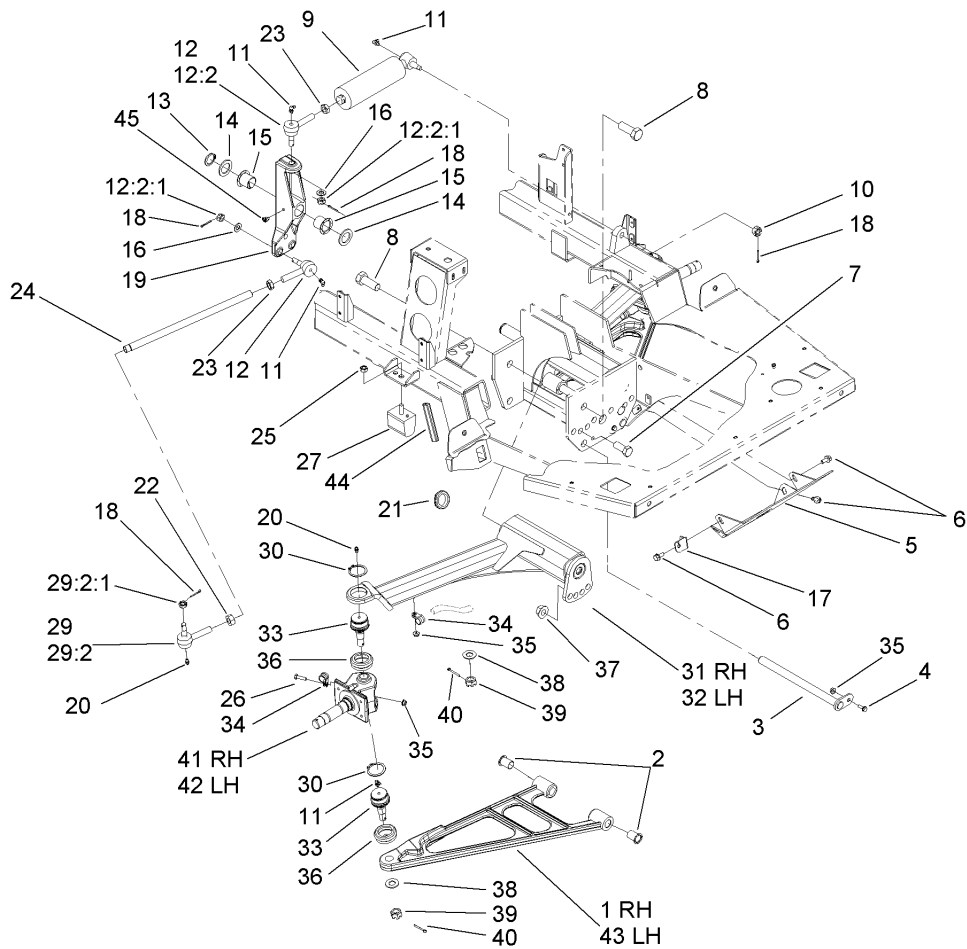

Front Suspension Assembly

Ref	Part No.	Qty.	Description
1	108-3317-03	1	A-Arm, RH
2	100-8541	4	Bushing-A Arm
3	100-8544	2	Pivot Pin ASM
4	3234-4	2	Screw-HHF
5	108-3671-03	1	Plate-Skid
6	3234-5	4	Screw-HHF
7	327-4	2	Screw-HH
8	328-24	4	Screw-HH
9	100-8278	1	Cylinder-Steering
10	32136-13	1	Nut-SHH
11	302-60	6	Fitting-Grease, 90 DEG
12	112772-03	3	RH Ball Joint ASM
12:2		1	Joint-Ball, RH
12:2:1	915031	1	Nut
13	100-6785	1	Ring-Retaining
14	3-6781	2	Washer-Thrust
15	256-318	2	Bearing-Nyliner
16	3256-25	3	Washer-Flat
17	108-3556	1	Bracket-Cable
18	3272-11	6	Pin-Cotter
19	108-3670	1	Pivot-Steering
20	302-5	4	Fitting-Grease
21	240-3	1	Grommet-Rubber
22	3218-21	2	Nut-Jam

Ref	Part No.	Qty.	Description
23	3220-11	3	Nut-Jam
24	100-8534	2	Tie Rod-Steering
25	48-9520	2	Nut
26	321-6	2	Screw-HH
27	87-3470	2	Bumper-Axle, Rear
29	112771-03	2	LH Ball Joint ASM
29:2		1	Joint-Ball, LH
29:2:1	915031	1	Nut
30	32151-104	4	Ring-Retaining, External
31	100-8414	1	RH Axle ASM
32	100-8413	1	LH Axle ASM
33	87-1430	4	Joint-Ball
34	2412-134	4	R-Clamp
35	32128-33	6	Nut-HF
36	87-2420	4	Seal-Joint, Ball
37	32128-50	2	Nut-Flange
38	3256-27	4	Washer-Flat
39	32136-2	4	Nut-SHH
40	3272-17	4	Pin-Cotter
41	108-3353	1	Spindle-RH
42	108-3354	1	Spindle-LH
43	108-3318-03	1	A-Arm, LH
44	108-3653	1	Trim-Edge
45	302-11	1	Fitting-Lube, 45 DEG

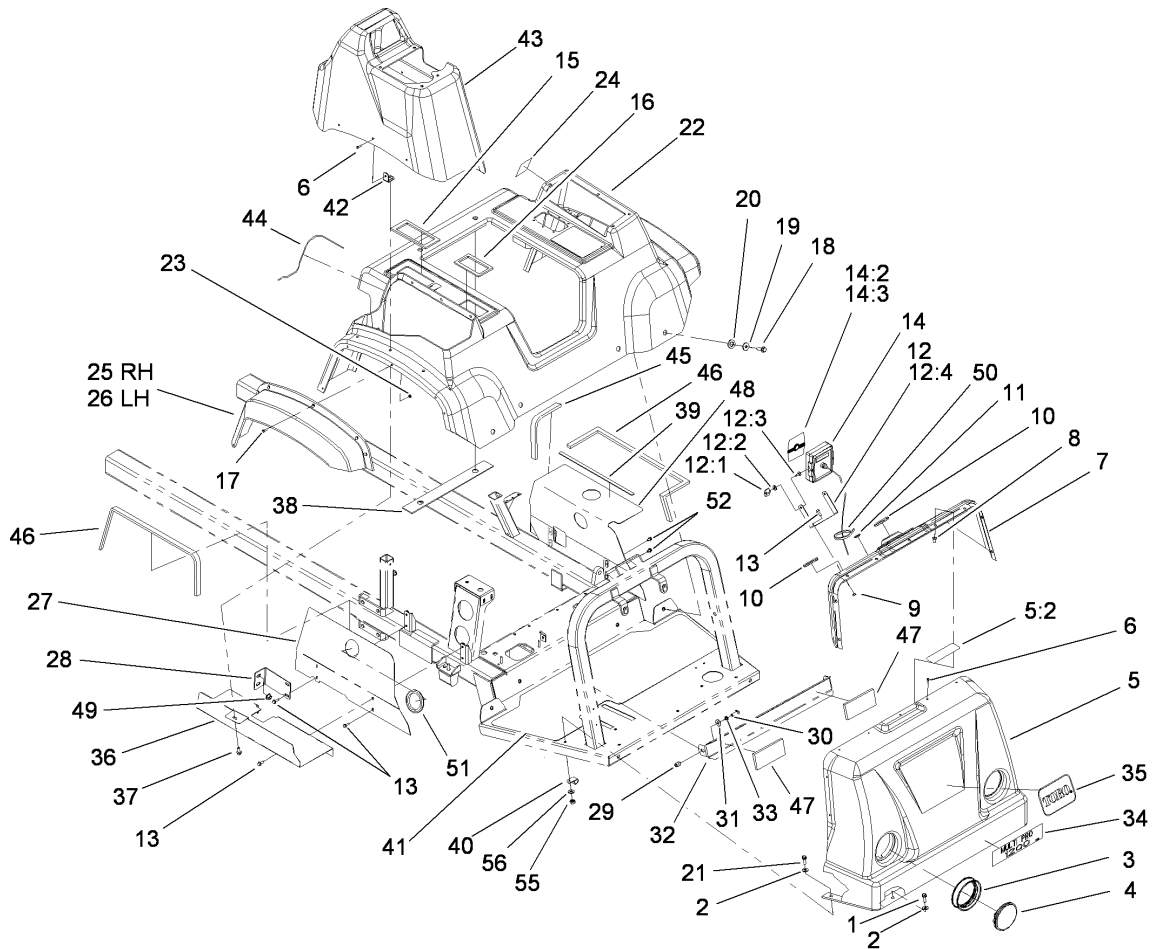

Engine Cover Assembly

Ref	Part No.	Qty.	Description
1	3234-17	4	Screw-HHF
2	3256-3	5	Washer-Flat
3	99-7311	2	Mount-Headlight
4	99-7310	2	Headlight
5	110-5225	1	Hood ASM
5:2	110-5240	1	Decal-Caution, Rider
6	3250-25	19	Screw-PPH
7	100-6777	1	Dash Panel ASM
8	100-8450	21	Nut-Well
9	32128-33	2	Nut-HF
10	40764	2	Grommet
11	94-7290	1	Plug-Hole
12		1	Monitor Mounting Bracket Kit
12:1	99-0667	2	Knob
12:2	99-0730	2	Washer-Rubber
12:3	106-4868	2	Screw-CARR
12:4	99-0576	1	Bracket
13	3234-4	6	Screw-HHF
14	108-3311	1	Spray Monitor ASM
14:2	108-3306	1	Decal-Monitor
14:3	108-3308	1	Decal-Monitor, Ce
15	100-8436	1	Seal-Foam
16	100-8437	1	Seal-Foam
17	32105-13	12	Screw-HWH

Ref	Part No.	Qty.	Description
18	3234-24	6	Screw-HHF
19	107-8634	6	Seatbase-Spacer
20	100-8468	6	Washer-Rubber
21	3234-36	1	Screw-HHF
22	104-8875	1	Seat Base ASM
23	3290-148	12	Nut-HF
24	112-7989	1	Lable-Engine, Exhaust
25	94-7074	1	Flare-Fender, RH
26	94-7075	1	Flare-Fender, LH
27	104-8848-03	1	Panel-Shield, RH
28	100-8623	2	Bracket-Engine Cover Support, Rear
29	32148-9	2	Insert-Nut
30	323-6	2	Screw-HH
31	3256-4	2	Washer-Flat
32	100-6731-03	1	Shield-Headlight
33	3253-21	2	Washer-Lock
34	106-5129	1	Decal
35	62-5550	1	Decal
36	104-8852-03	1	Panel-Fender, Inner
37	3234-5	3	Screw-HHF
38	100-8463	1	Seal-Foam
39	100-8499	2	Seal-Foam
40	98-2390	1	Clamp-R

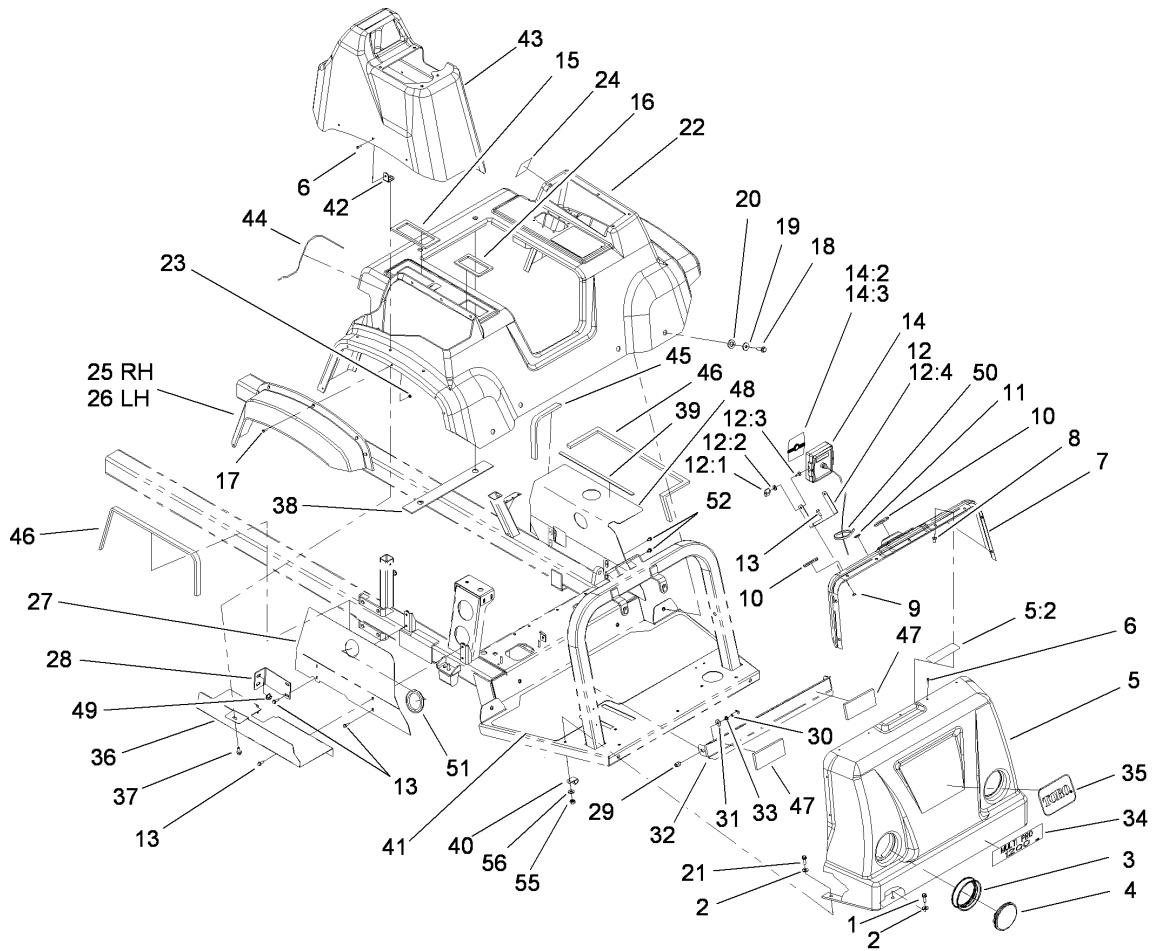

Engine Cover Assembly (continued)

Ref	Part No.	Qty.	Description
41	100-8622	1	Tread-Floor
42	104-8854-03	3	Console Bracket ASM
43	104-8867	1	Valve Console ASM
44	104-8870	1	Trim-Edge
45	100-8444	1	Trim-Shield, Front And Rear
46	100-8423	2	Trim-Shield, Top
47	106-4872	2	Pad-Foam, Headlight
48	100-8448-03	1	Panel-Shield, LH
49	32128-43	2	Nut-Flange
50	3290-379	4	Tie-Cable
51	237-164	3	Grommet
52	3234-26	4	Screw
55	3296-29	1	Nut-Lock, NI
56	3256-74	1	Washer-Flat

--	--	--	--

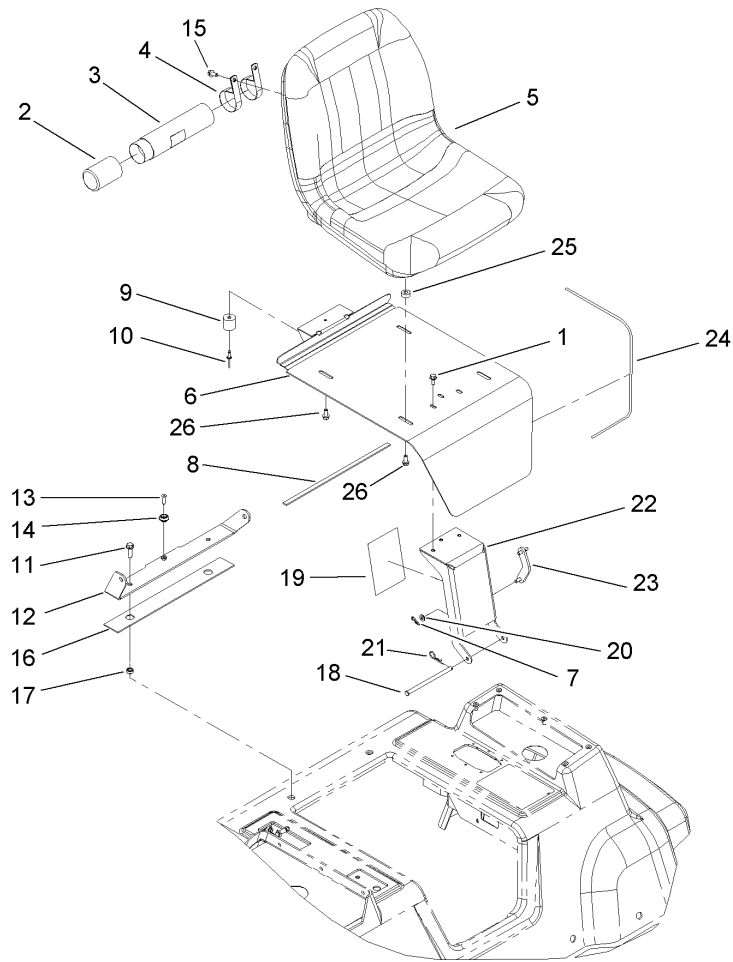

Seat Support Assembly

Ref	Part No.	Qty.	Description
1	3234-5	3	Screw-HHF
2	104-7048	1	Cap-Housing
3	104-7050	1	Housing-Manual
4	2412-133	2	R-Clamp
5	112-2923	1	Seat ASM
6	108-3687-03	1	Bracket-Seat
7	3290-307	1	Pin-Hair
8	100-8499	1	Seal-Foam
9	99-7830	1	Rubber Receptical ASM
10	3290-412	1	Rivet
11	3234-24	2	Screw-HHF
12	107-8614-03	1	Bracket-Seatbelt
13	32108-5	1	Screw-FH
14	99-7833	1	Post-Holding
15	33104-016	2	Screw-HHF
16	100-8463	1	Seal-Foam
17	100-8464	2	Spacer
18	100-8501	1	Pin-Clevis
19	108-3699	1	Decal-Fuse, Block
20	3256-23	1	Washer-Flat
21	9335054	1	Pin-Hair
22	106-4958-03	1	Bracket-Hinge
23	106-5171	1	Prop-Seat
24	100-8500	1	Trim-Seat

Ref	Part No.	Qty.	Description
25	104-8426	4	Spacer
26	33104-025	4	Screw-HHF

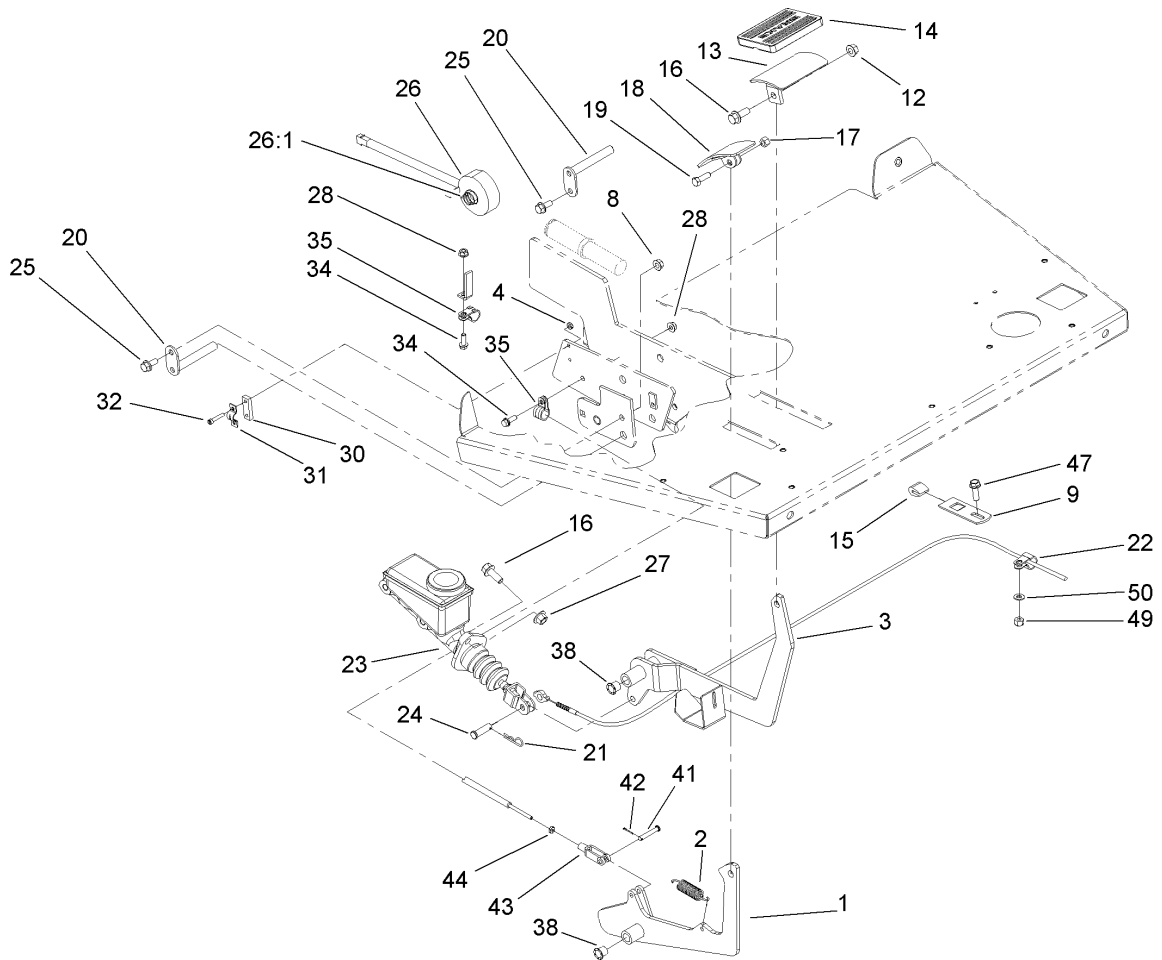

Brake and Accelerator Pedal Assembly

Ref	Part No.	Qty.	Description
1	100-8367-03	1	Accelerator-Lever
2	67-1450	1	Spring-Idler
3	100-8553-03	1	Brake-Lever
4	3296-2	2	Nut-Lock
8	32128-20	2	Nut-HF
9	104-8791-03	1	Plate-Pedal, Stop
12	32128-21	1	Nut-HF
13	100-8422-03	1	Pedal Bracket ASM
14	7-3900	1	Pad-Brake
15	100-6702	3	Stop-Lever, Pedal
16	3234-11	3	Screw-HHF
17	32153-3	1	Nut-Hex, Side Deform
18	93-8969-03	1	Pedal
19	322-5	1	Screw-HH
20	100-8554	2	Pin-Pivot
21	3290-250	1	Pin-Hair
22	98-2390	1	Clamp-R
23	94-3800	1	Master Cylinder ASM
24	283-42	1	Pin-Clevis
25	3234-5	2	Screw-HHF
26	99-8090	1	Magnet ASM
26:1	93-6601	1	Spring-Compression
27	32128-43	2	Nut-Flange
28	32128-33	2	Nut-HF

Ref	Part No.	Qty.	Description
30	100-8561	1	Plate-Spacer
31	100-8560	1	Bracket-Throttle
32	3274-81	2	Screw-HSH
34	3234-4	2	Screw-HHF
35	2412-134	2	R-Clamp
38	256-257	4	Bushing-Nyliner
41	283-66	1	Pin-Clevis
42	3272-1	1	Pin-Cotter
43	282-28	1	Clevis-Adjustable
44	3219-14	1	Nut-Hex
47	3234-17	1	Screw-HHF
49	3296-29	1	Nut-Lock, NI
50	3256-74	1	Washer-Flat

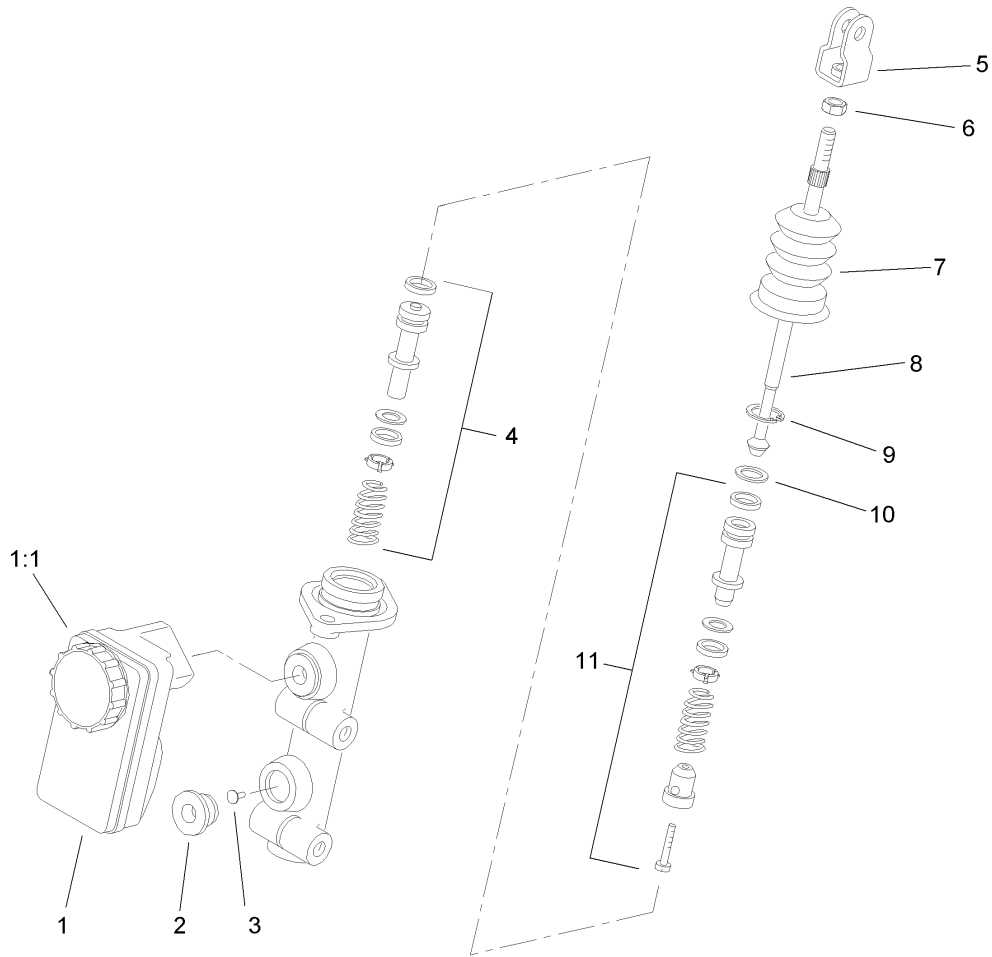

Master Cylinder Assembly No. 94-3800

Ref	Part No.	Qty.	Description
1	87-3040	1	Reservoir-Cylinder, Master
1:1	92-4112	1	Cap ASM
2	93-8971	2	Seal-Port, Flange
3	92-4103	1	Pin-Stop
4	92-4102	1	Secondary Piston ASM
5	92-4110	1	Clevis
6	21-0360	1	Nut-Hex
7	94-5209	1	Cover-Dust
8	94-5210	1	Rod-Push
9	92-4109	1	Ring-Snap
10	92-4108	1	Retainer-Washer
11	92-4101	1	Primary Piston ASM

--	--	--	--

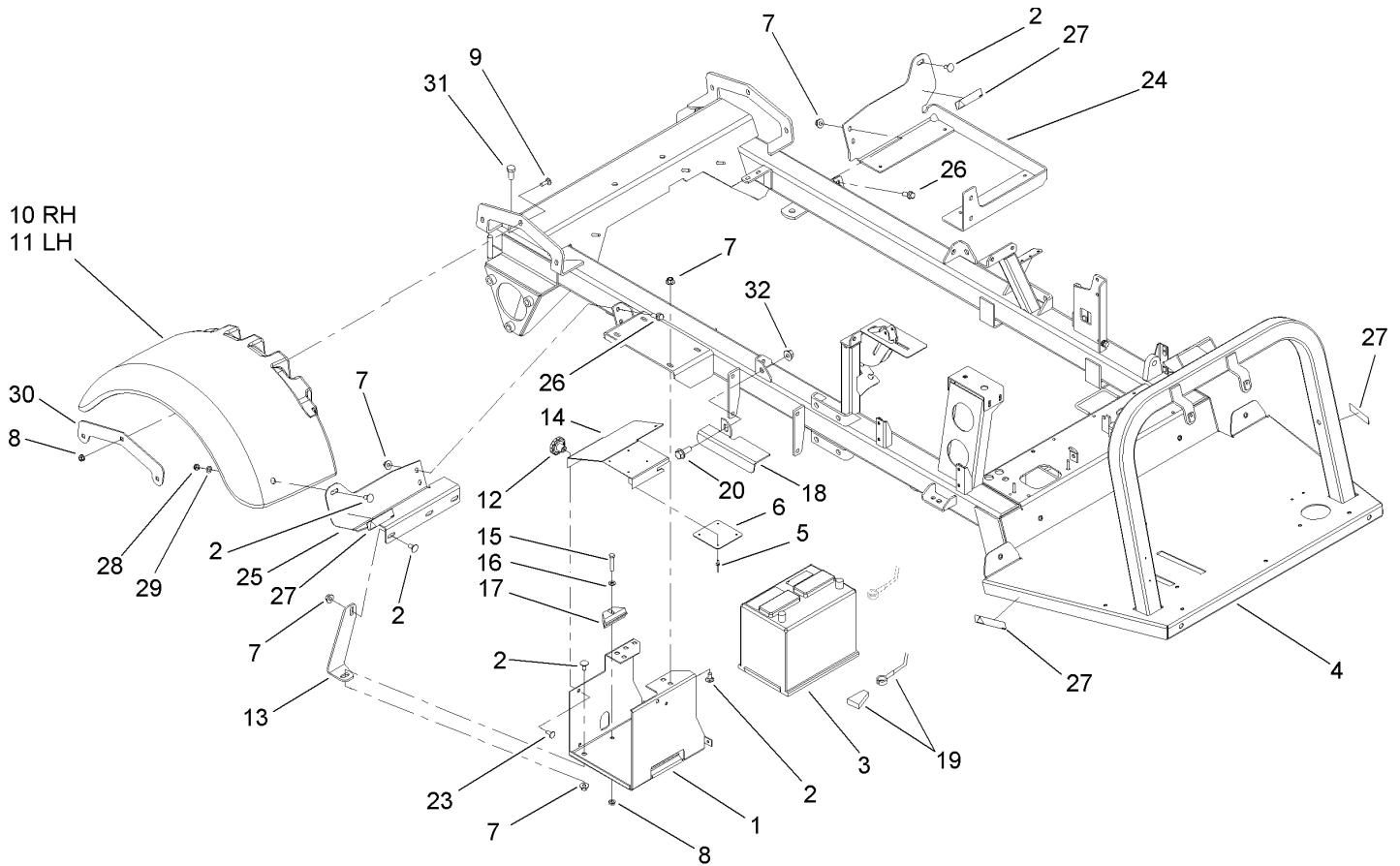

Rear Fender and Battery Mount Assembly

Ref	Part No.	Qty.	Description
1	87-5120-03	1	Bracket-Holder, Battery
2	3231-1	6	Screw-CARR
3	106-5187	1	Battery
4	108-3665-03	1	Frame-Main
5	3269-27	4	Rivet-Snap
6	87-7620	1	Shield-Terminal, Battery
7	32128-43	10	Nut-Flange
8	32128-20	7	Nut-HF
9	3230-2	6	Bolt-CARR
10	112-6806	1	Fender-RH
11	112-6805	1	Fender-LH
12	19-4050	2	Knob
13	100-8201-03	1	Support-Battery
14	87-5130-03	1	Cover-Battery
15	322-9	1	Screw-HH
16	3256-23	1	Washer-Flat
17	66-2490	1	Retainer-Battery
18	110-5243-03	1	Guard-Pump
19	108-9472	1	Cable-Battery, Positive
20	3234-32	1	Screw-HHF
23	3230-23	2	Screw-CARR
24	108-3664-03	1	Bracket-Mount
25	108-3659-03	1	Support-Fender
26	3234-11	6	Screw-HHF

Ref	Part No.	Qty.	Description
27	108-3252	4	Decal-Torque, Ce
28	3296-59	6	Nut-Lock, NI
29	3256-4	2	Washer-Flat
30	108-3656-03	2	Bracket-Fender
31	325-4	2	Screw-HH
32	32128-49	1	Nut-HHF

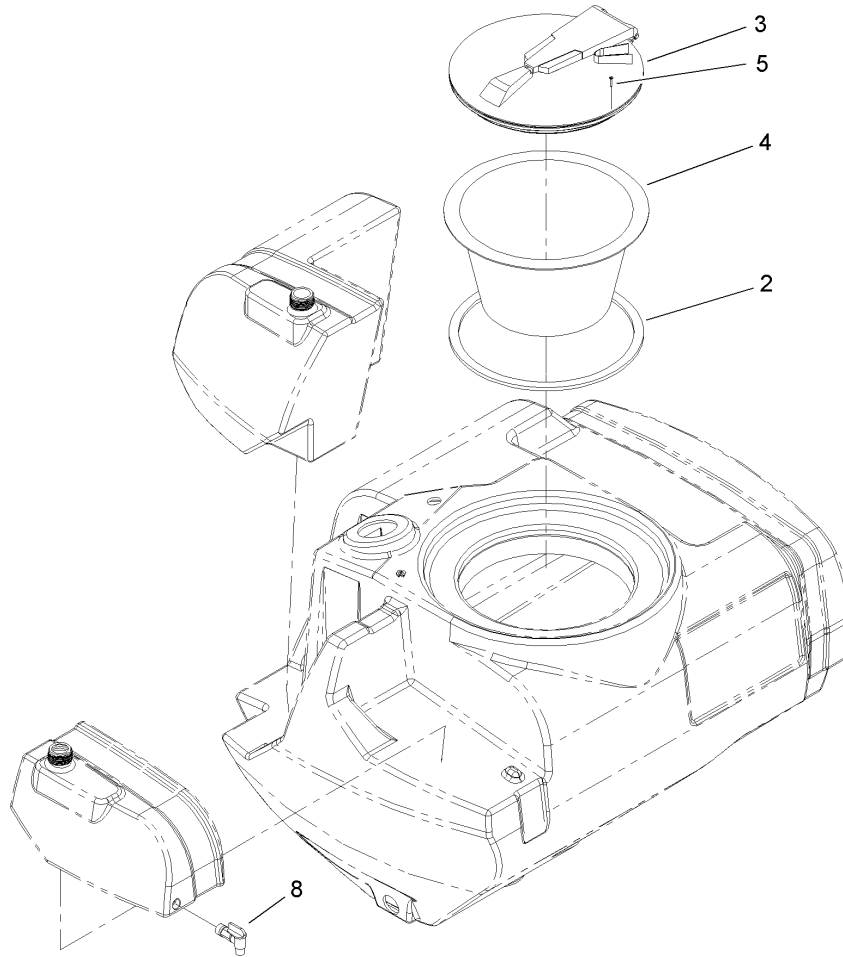

Main Tank Assembly

Ref	Part No.	Qty.	Description				
2	106-4991	1	Seal-Lid				
②3		1	Screw Type Tank Lid ASM				
4	104-9051	1	Basket-Strainer				
5	107-8635	8	Screw-PFH				
8	106-4925	1	Spigot-90 DEG				

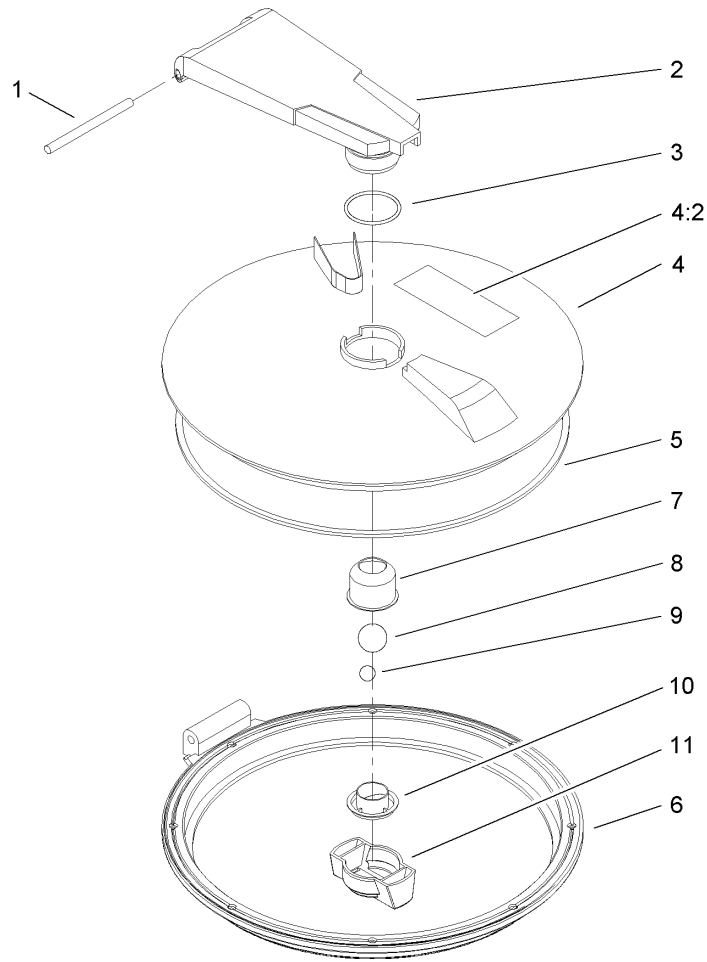

Lid Assembly

Ref	Part No.	Qty.	Description				
1	106-5000	1	Pin-Pivot				
2	106-5001	1	Arm				
3	106-5002	1	O-Ring				
4	106-1369	1	Lid				
4:2	93-0688	1	Decal-Warning, Chemical				
5	106-5004	1	Seal-Lid				
6	106-5005	1	Ring				
7	106-5006	1	Cup-Vent				
8	106-5007	1	Ball-Floating				
9	106-5008	1	Ball-Weight				
10	106-5009	1	Holder-Ball				
11	106-5010	1	Nut-Wing				

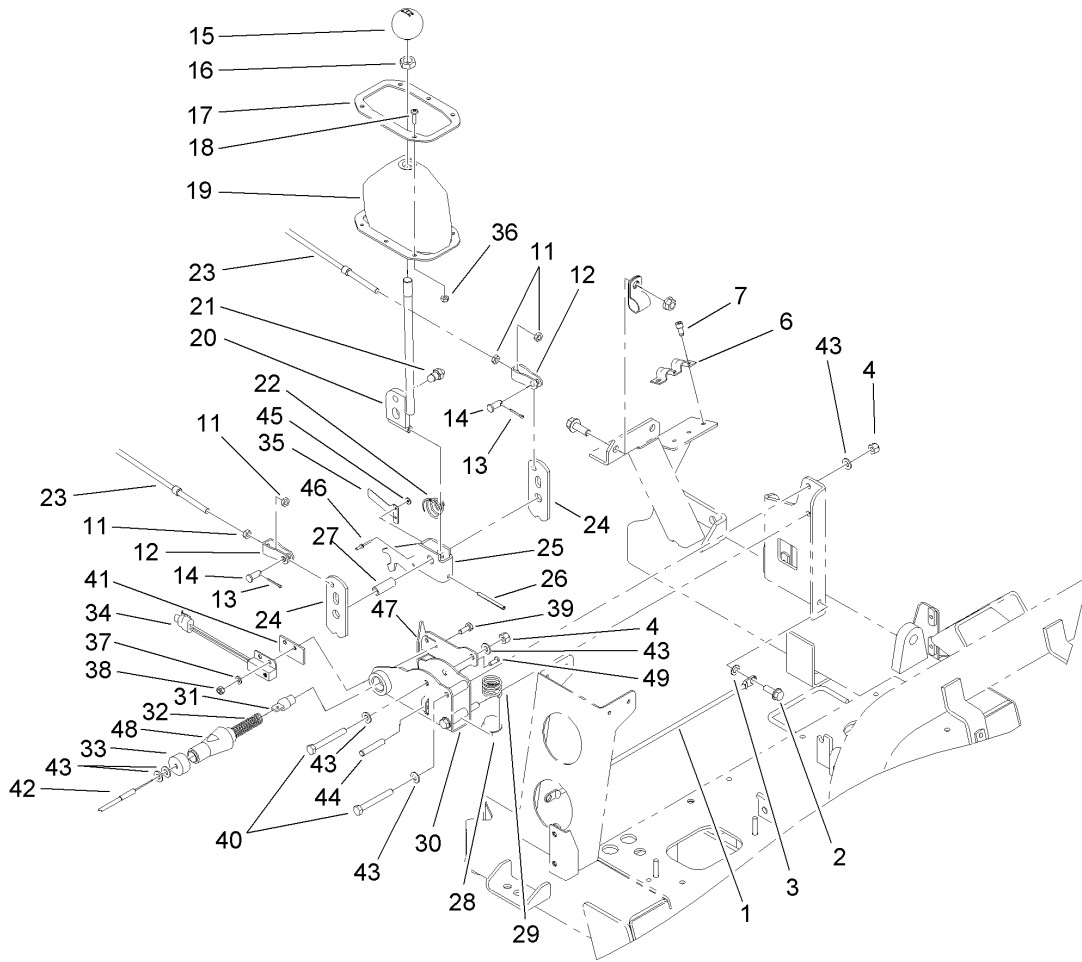

Shifter Assembly

Ref	Part No.	Qty.	Description
1	108-3698	1	Cable-Battery, Negative
2	32144-14	1	Screw-HWHTF
3	3255-8	1	Washer-Lock
4	3296-29	3	Nut-Lock, NI
6	87-4960	1	Clamp-Cable
7	65-5220	3	Screw-HSH, Thread Forming
11	3220-1	4	Nut-Jam
12	87-2310	2	Clevis-Cable
13	3272-6	2	Pin-Cotter
14	283-62	2	Pin-Clevis
15	87-6720	1	Knob-Shift
16	3218-18	1	Nut-Jam
17	87-3760-03	1	Plate-Boot, Shift
18	3250-13	6	Screw-PPH
19	87-8620	1	Shift Boot ASM
20	87-2040	1	Shift Lever ASM
21	87-3650	1	Pin-Shift
22	87-2900	1	Spring-Compression
23	100-8359	2	Cable-Shift
24	87-3540	2	Link-Shift
25	108-3565	1	Bracket-Shifter
26	32121-48	1	Pin-Spring
27	108-3570	3	Tube-Shifter
28	87-3530	1	Button-Shifter

Ref	Part No.	Qty.	Description
29	87-3660	1	Spring-Compression
30	110-5106	1	Clevis
31	108-3558	1	Pin-Retracting
32	108-3557	1	Spring
33	108-3564	1	Cap-Spring
34	105-0023	1	Switch-Proximity
35	110-5125	1	Flag-Sensor, Proximity
36	3296-2	6	Nut-Lock
37	33093-00	2	Washer-Flat
38	33023-00	2	Nut-Lock
39	33113-016	2	Screw-HH
40	322-12	3	Screw-HH
41	110-5102	1	Spacer-Insulator
42	108-3553	1	Shift Lock Cable ASM
43	3256-74	8	Washer-Flat
44	3290-507	1	Pin-Dowel
45	5-1254	2	Washer
46	3290-55	2	Rivet-Pop
47	110-5101	1	Bracket-Mount, Switch
48	110-5103	1	Tube-Shifter
49	3250-12	1	Screw-PPH

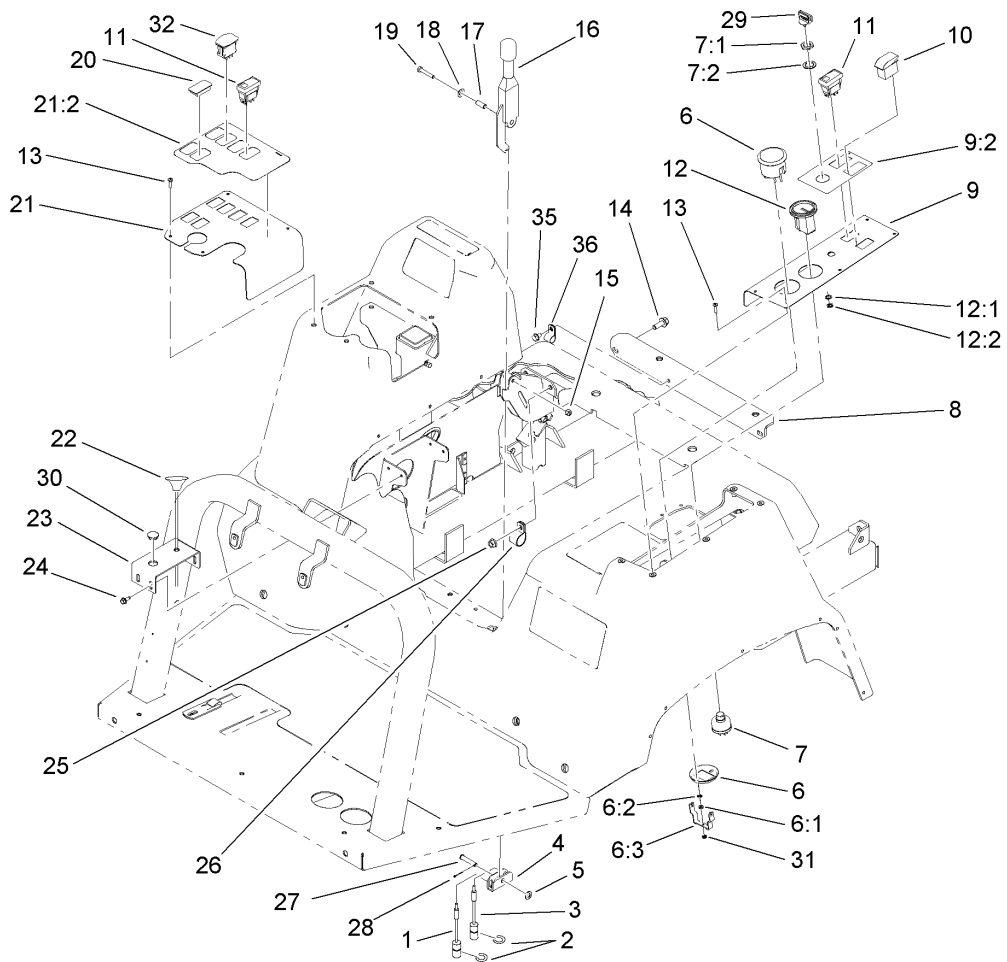

Parking Brake and Console Assembly

Ref	Part No.	Qty.	Description
1	87-8240	1	Cable-Brake
2	32120-47	2	Ring-Retaining, External
3	100-8261	1	Cable-Park Brake, RH
4	87-3480	1	Bracket-Equalizer, Cable
5	3256-23	1	Washer-Flat
6	98-2160	1	Voltmeter
6:1	3217-27	1	Nut-Hex
6:2	3255-25	1	Washer-Lock
6:3	78-0080	1	Clamp-Mounting
7	83-0020	1	Switch-Ignition
7:1	218-461	1	Nut-HH
7:2	3254-5	1	Washer-Tooth
8	106-4859-03	1	Bracket-Seatbox
9	100-8452	1	Vehicle Control Panel ASM
9:2	100-8470	1	Decal-Controls
10	100-8469	1	Switch-Rocker
11	104-9007	2	Switch-Rocker
12	66-2950	1	Gauge-Hourmeter
12:1	3255-20	2	Washer-Lock
12:2	3217-25	2	Nut-Hex
13	3250-25	9	Screw-PPH
14	3234-11	2	Screw-HHF
15	3296-42	1	Nut-Lock, NI
16	87-2710	1	Lever-Brake

Ref	Part No.	Qty.	Description
17	87-4710	1	Spacer-Brake, Parking
18	3290-477	1	Washer-Curved
19	321-9	1	Screw-HH
20	99-7420	3	Plug-Hole
21	104-8866	1	Spray Control Panel ASM
21:2	104-8749	1	Decal-Control, Spray
22	41697	1	Choke-Control
23	100-8385-03	1	Bracket-Speed, Throttle
24	32144-10	4	Screw-HWH
25	32128-21	2	Nut-HF
26	2412-39	2	R-Clamp
27	94-3829	1	Pin-Clevis
28	3272-6	1	Pin-Cotter
29	63-8360	2	Key-Ignition
30	93-0830	1	Plug-Hole
31	32149-9	2	Nut-Keps
32	100-1535	2	Switch
35	32144-70	1	Screw-HWHTF
36	2412-39	1	R-Clamp

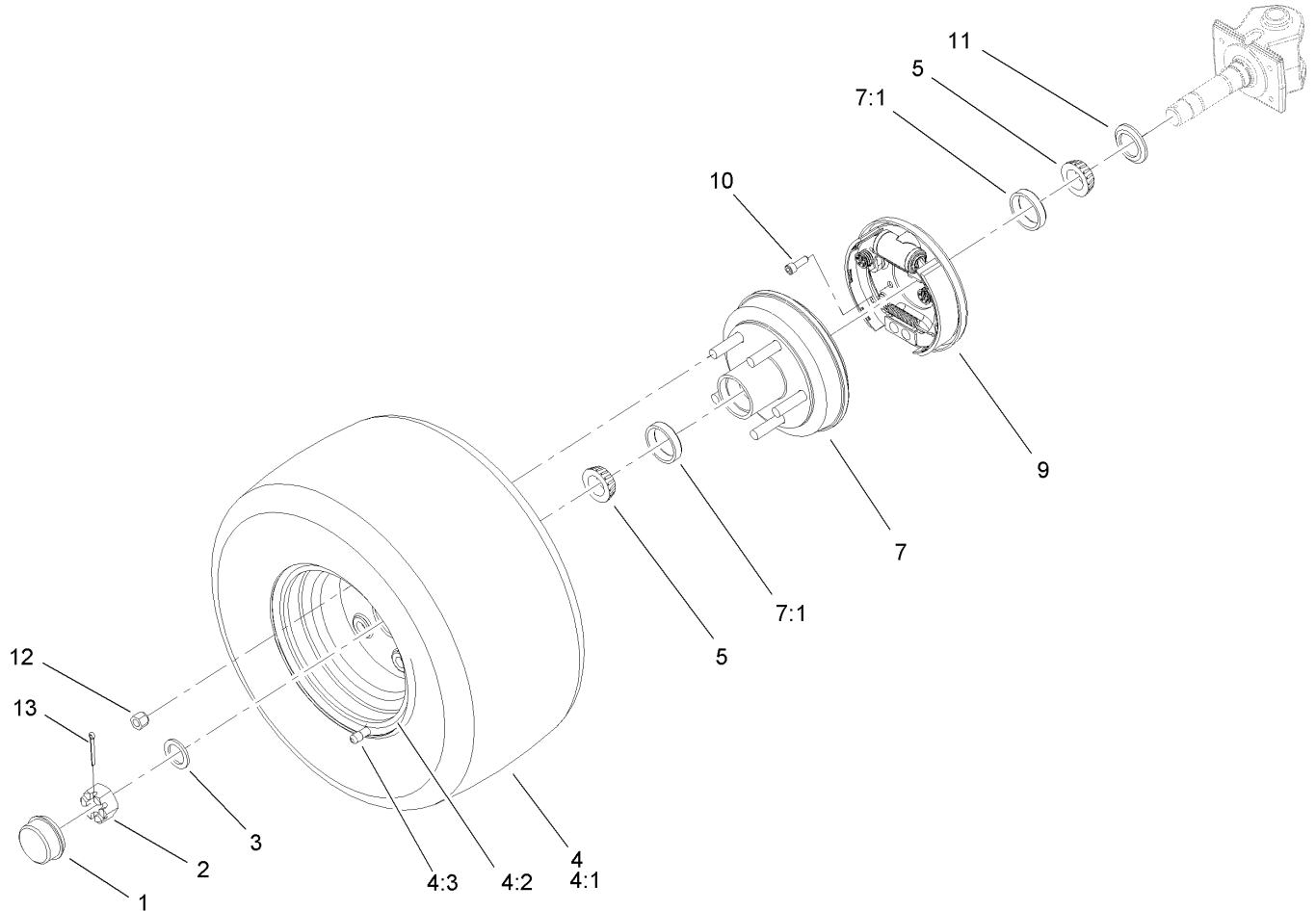

Front Wheel Assembly

Ref	Part No.	Qty.	Description
1	241-119	2	Cap-Dust
2	1-809082	2	Nut-SHH
3	27-1850	2	Washer-Pivot
4	110-5135	2	Front Tire And Wheel ASM
4:1	110-5133	1	Tire
4:2	241-121	1	Wheel ASM
4:3	232-27	1	Stem-Valve
5	254-92	4	Cone-Bearing, Outer
7	100-8287	2	Hub/Drum-Front
7:1	254-72	2	Bearing-Cup, Tapered
9	100-8285	2	Front Brake ASM
10	3273-14	8	Screw-HSH
11	253-129	2	Seal
12	321077	10	Nut-Wheel
13	3272-13	2	Pin-Cotter

--	--	--	--

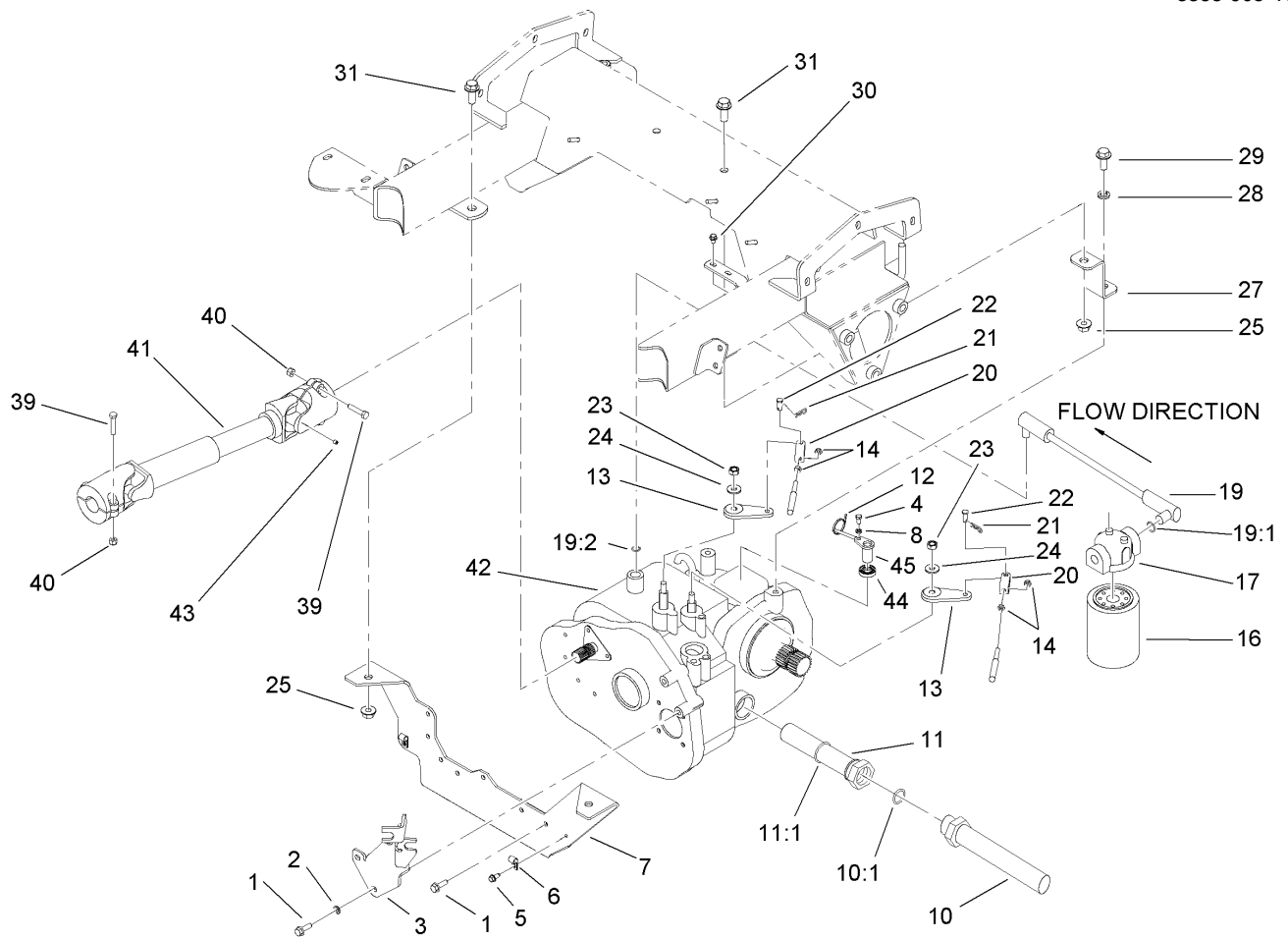

Transaxle Installation Assembly

Ref	Part No.	Qty.	Description
1	33104-025	10	Screw-HHF
2	3253-4	10	Washer-Lock
3	107-8749-03	1	Bracket-Cable
4	33113-012	1	Screw-HH
5	32144-10	2	Screw-HWH
6	2412-89	2	Clamp
7	100-8531-03	1	Transaxle-Mount
8	48-8020	1	Washer-Spring
10	100-8250	1	Hose-Suction
10:1	237-81	1	O-Ring
11	87-3990	1	Strainer-Transaxle
11:1	237-123	1	O-Ring
12	3290-379	4	Tie-Cable
13	87-7960	2	Lever-Shift
14	3220-1	4	Nut-Jam
16	54-0110	1	Filter-Oil, Transmission
17	87-8780	1	Head-Filter
19	100-8254	1	Hose-Return, Axle
19:1	237-79	1	O-Ring
19:2	237-42	1	O-Ring
20	87-2310	2	Clevis-Cable
21	3290-307	2	Pin-Hair
22	283-62	2	Pin-Clevis
23	48-9520	2	Nut

Ref	Part No.	Qty.	Description
24	80-6990	2	Washer-Hardened
25	32128-49	2	Nut-HHF
27	100-8220-03	2	Strap-Mount, Transaxle
28	3253-7	2	Washer-Lock
29	33106-030	2	Screw-HHF
30	3234-33	2	Screw-HHF
31	3234-32	4	Screw-HHF
39	322-7	4	Screw-HH
40	3296-29	4	Nut-Lock, NI
41	100-8293	1	Shaft-Drive, Input
42	104-9078	1	Transaxle
43	3245-32	1	Screw-HSH
44	92-3735	1	Seal-Oil, Sensor
45	85-4350	1	Sensor-Gear tooth

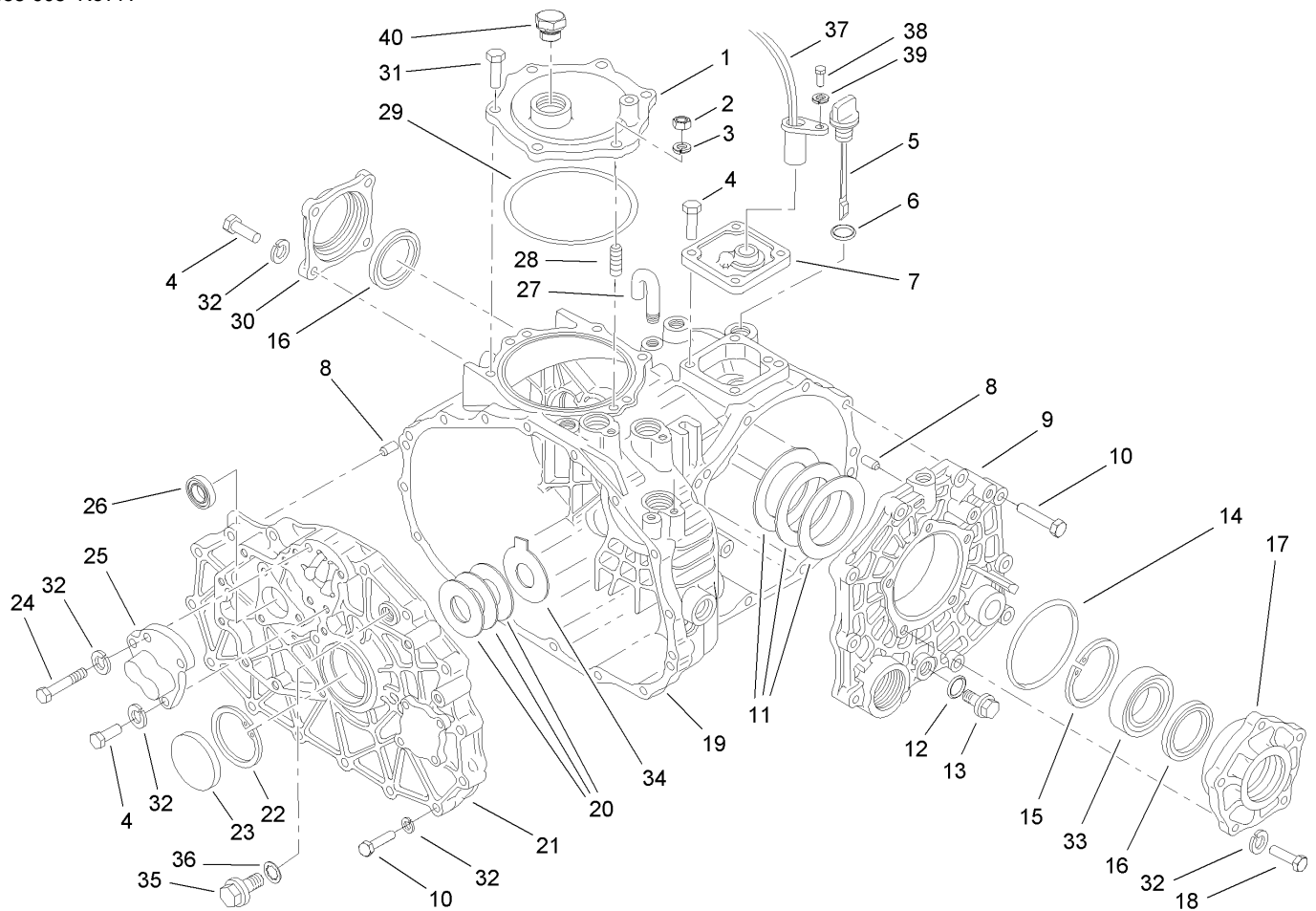

Case Assembly Transaxle Assembly No. 104-9078

Ref	Part No.	Qty.	Description
1	100-8595	1	Cover-PTO
2	48-7930	1	Nut
3	92-0762	1	Washer-Spring
4	33114-025	11	Screw-HH
5	92-0662	1	Cap-Oil
6	92-0788	1	O-Ring
7	92-3736	1	Cover ASM
8	92-0765	4	Pin-Parallel
9	92-0653	1	Cover-Side
10	33114-040	25	Screw-HH
11	92-0809	1	Set-Shim
12	92-0787	1	O-Ring
13	92-0773	1	Plug-Drain
14	92-0789	1	O-Ring
15	92-0760	1	Ring-Snap
16	92-0793	2	Seal-Oil
17	92-0654	1	Carrier-Differential
18	48-7730	5	Screw-HH
19	92-0651	1	Case-Transmission
20	100-4460	1	Shim Set
21	100-4461	1	Plate-Center
22	92-0759	1	Ring-Snap
23	92-0807	1	Cap-Sealing
24	48-7560	1	Bolt-HH

Ref	Part No.	Qty.	Description
25	92-0706	1	Shaft-Fork
26	92-0791	1	Seal-Oil
27	92-0743	1	Breather-Air
28	92-0804	1	Stud
29	92-0790	1	O-Ring
30	92-0655	1	Cover-Seal, Axle
31	92-0796	5	Bolt
32	3253-4	42	Washer-Lock
33	92-0775	2	Bearing
34	100-4465	1	Shim (W/Tab)
35	100-6924	1	Plug
36	100-6925	1	Packing
37	85-4350	1	Sensor-Gear tooth
38	48-7610	1	Screw
39	48-8020	1	Washer-Spring
40	110-5196	1	Plug-Transaxle
●99	100-6928	1	Bolt
●99	100-8594	1	Cover-Shaft, Input

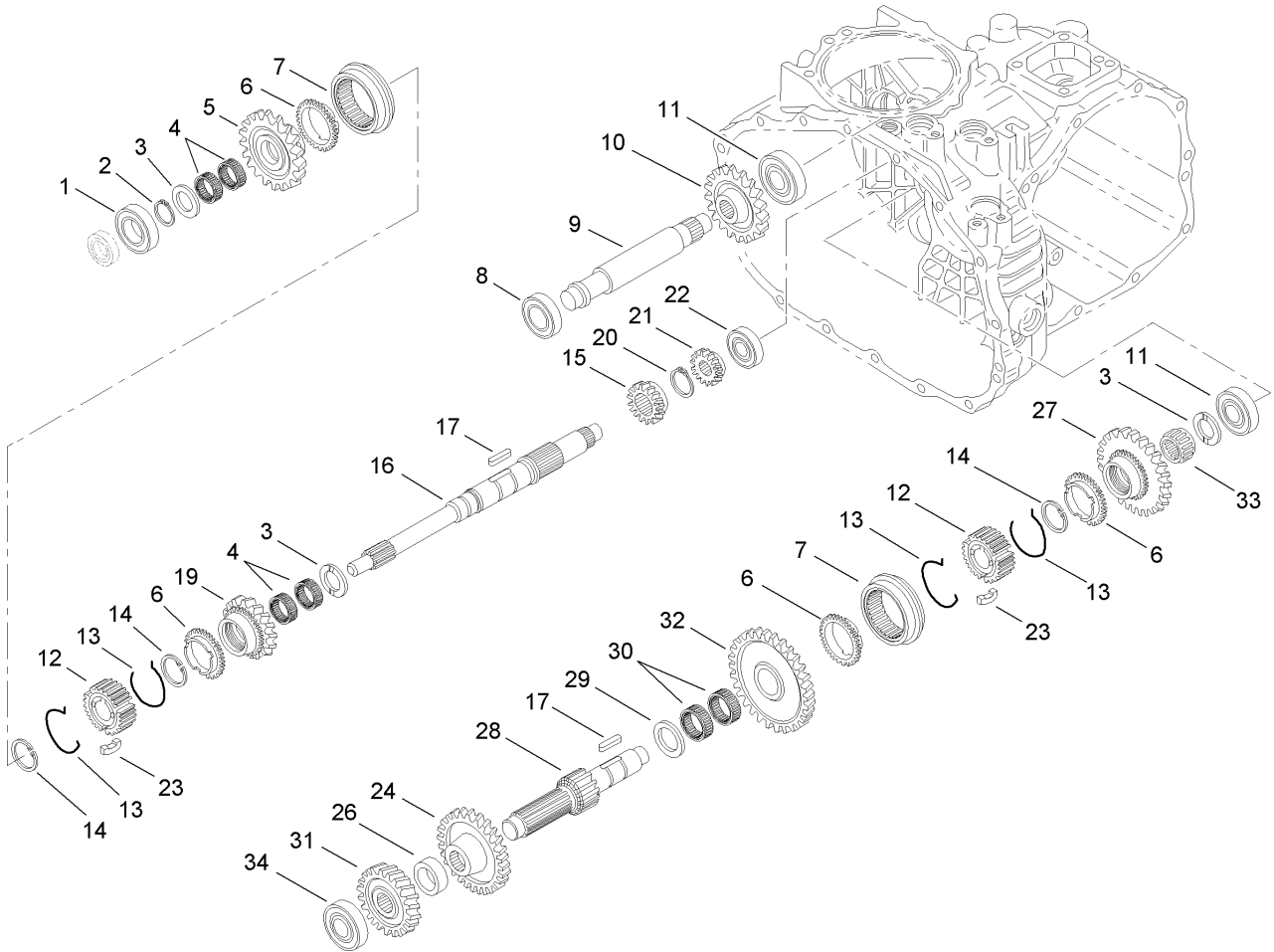

Gear Shaft Assembly Transaxle Assembly No. 104-9078

Ref	Part No.	Qty.	Description
1	251-8	1	Bearing-Ball
2	92-0753	1	Ring-Snap
3	92-0740	3	Washer-Thrust
4	92-0781	4	Bearing-Needle
5	108-3694	1	Gear-Main, 36T
6	92-0667	3	Ring-Synchro
7	92-0668	2	Shifter-Synchro
8	251-346	2	Bearing-Ball
9	100-8602	1	Shaft-Idler, Reverse
10	92-0684	1	Gear-Reverse, 33 Tooth
11	92-0778	2	Bearing
12	92-0664	2	Hub-Synchro
13	92-0666	4	Spring-Synchro
14	92-0763	3	Ring-Snap
15	100-8598	1	Gear-Main, 20 Tooth
16	100-8596	1	Shaft-Main
17	92-0772	2	Key
19	108-3695	1	Gear-Main, 22T
20	92-0754	1	Ring-Snap
21	92-0673	1	Gear-Main, 14 Tooth
22	92-0650	1	Bearing
23	92-0665	6	Key-Synchro
24	92-0676	1	Gear-Reduction, 32 Tooth
26	100-8601	1	Collar

Ref	Part No.	Qty.	Description
27	92-0819	1	Gear-Reduction, 40 Tooth
28	92-0674	1	Shaft-Reduction
29	92-0682	1	Washer-Thrust
30	92-0681	2	Bearing-Needle
31	100-8599	1	Gear-Red, 25 Tooth
32	108-3697	1	Gear-Reduction, 47T
33	92-0782	1	Bearing-Needle
34	105-7985	1	Bearing

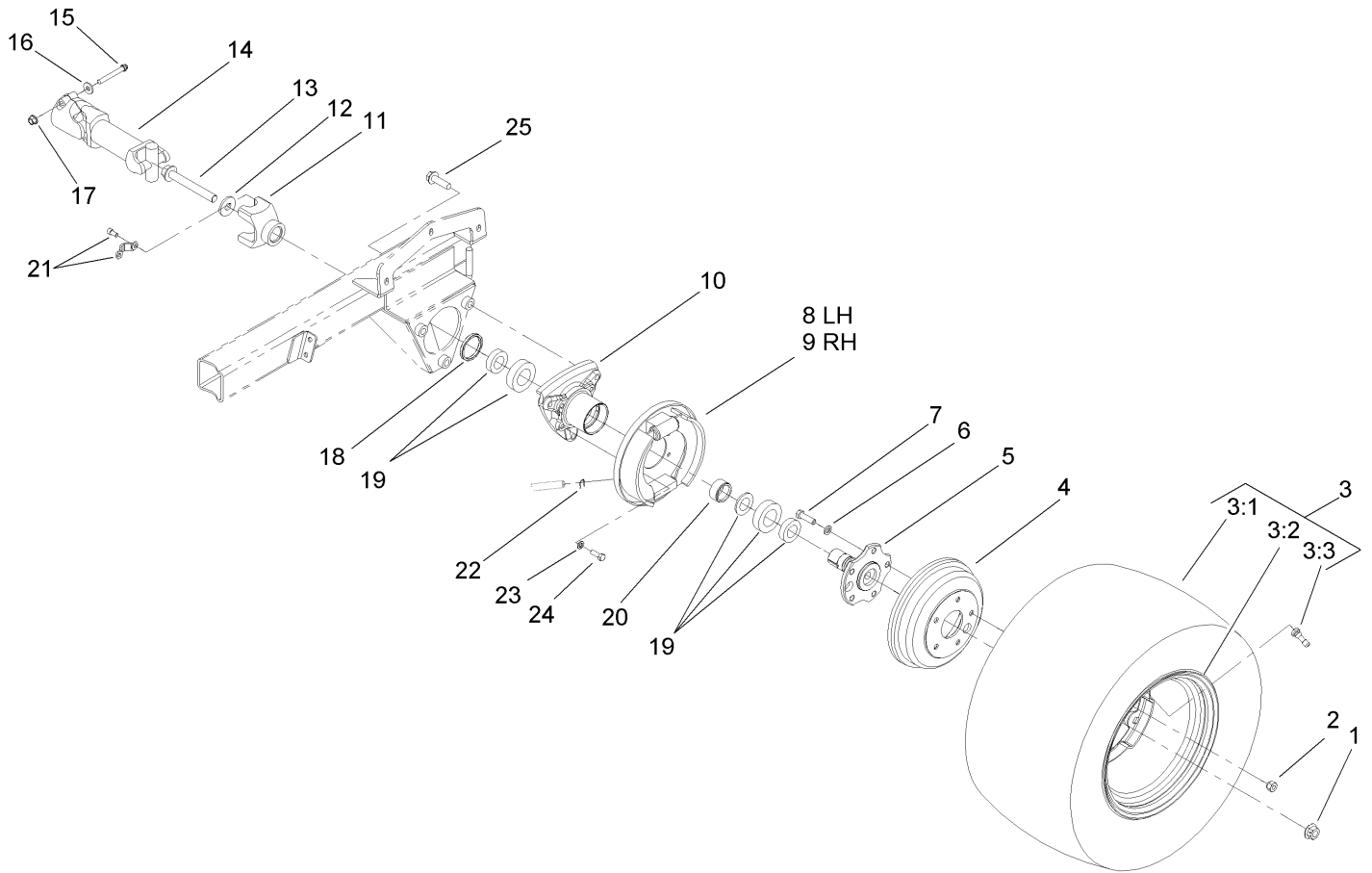

Rear Wheel and Brake Assembly

Ref	Part No.	Qty.	Description
1	105-1764	2	Nut-Flange, Side Lock
2	321077	10	Nut-Wheel
3	110-5134	2	Rear Tire And Wheel ASM
3:1	110-5132	1	Tire-Rear
3:2	87-6750	1	Wheel
3:3	232-27	1	Stem-Valve
4	93-7128	2	Drum-Brake
5	105-1717-03	2	Axle-Stub
6	3253-6	10	Washer-Lock
7	87-2080	10	Bolt-Hex, TAP
8	112-7961	1	LH Rear Brake ASM
9	112-7962	1	RH Rear Brake ASM
10	87-2240	2	Housing-Axle
11	92-4190	2	Yoke
12	104-9216	2	Washer-Hardened
13	105-1763	2	Screw-HHF
14	98-2918	2	Driveshaft ASM
15	98-2939	4	Screw-Cap
16	80-6990	4	Washer-Hardened
17	32128-36	4	Nut-HF
18	87-3590	2	Seal-Bearing
19	87-1970	2	Bearing
20	87-4060	2	Spacer-Bearing, Wheel
21	92-4189	2	Strap Kit

Ref	Part No.	Qty.	Description
22	87-3310	2	Clip-Cable, Brake
23	3253-21	8	Washer-Lock
24	323-6	8	Screw-HH
25	3234-22	6	Screw-HHF

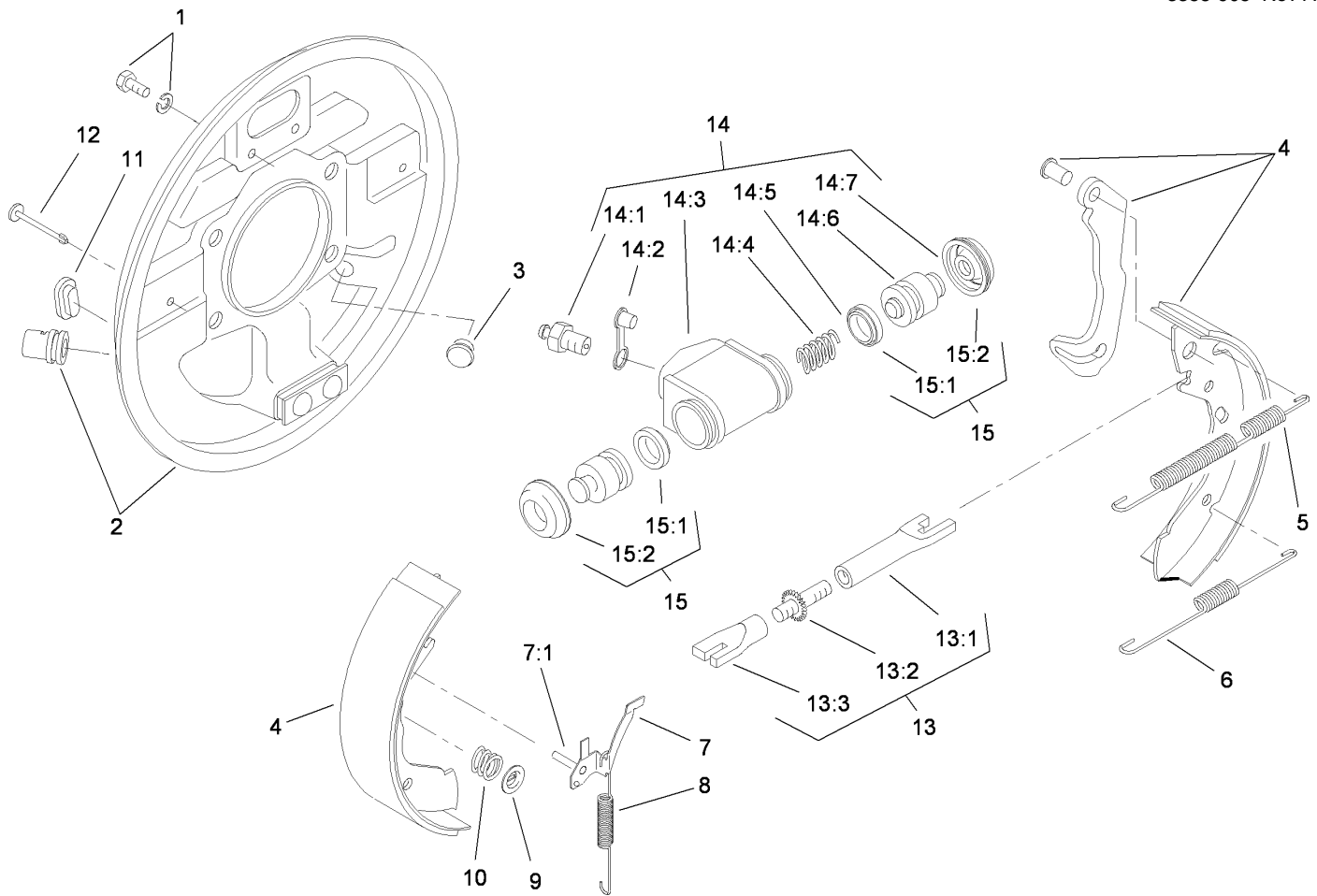

LH Rear Brake Assembly No. 112-7961

Ref	Part No.	Qty.	Description
1	92-4135	2	Bolt-Set
2	112-7968	1	Backing-Plate, LH
3	92-4146	1	Plunger ASM
4	112-7978	1	Lined Shoe Kit
5	92-4147	1	Spring-Return, Shoe (Upper, LH)
6	92-4149	1	Spring-Return, Shoe (Lower)
7	92-4123	1	LH Pawl Lever ASM
7:1		1	Pin-Pawl
8	92-4150	1	Spring-Adjuster, LH
9	92-4131	2	Washer-Hold Down, Shoe
10	92-4152	2	Spring-Hold Down, Shoe
11	92-4134	1	Plug-Inspection
12	92-4133	2	Pin-Hold Down, Shoe
13	92-4144	1	LH Adjuster ASM
13:1		1	Pushrod-Female
13:2		1	Bolt-Adjuster
13:3		1	Sleeve-Adjuster
14	92-4140	1	LH Wheel Cylinder ASM
14:1	92-4137	1	Screw-Bleed
14:2	92-4114	1	Cap-Screw, Bleed
14:3		1	Body
14:4		1	Spring
14:5		2	Seal-L Type
14:6		2	Piston

Ref	Part No.	Qty.	Description
14:7		2	Cover-Dust
15	92-4142	1	Seal Kit
15:1		2	Seal-L Type
15:2		2	Cover-Dust

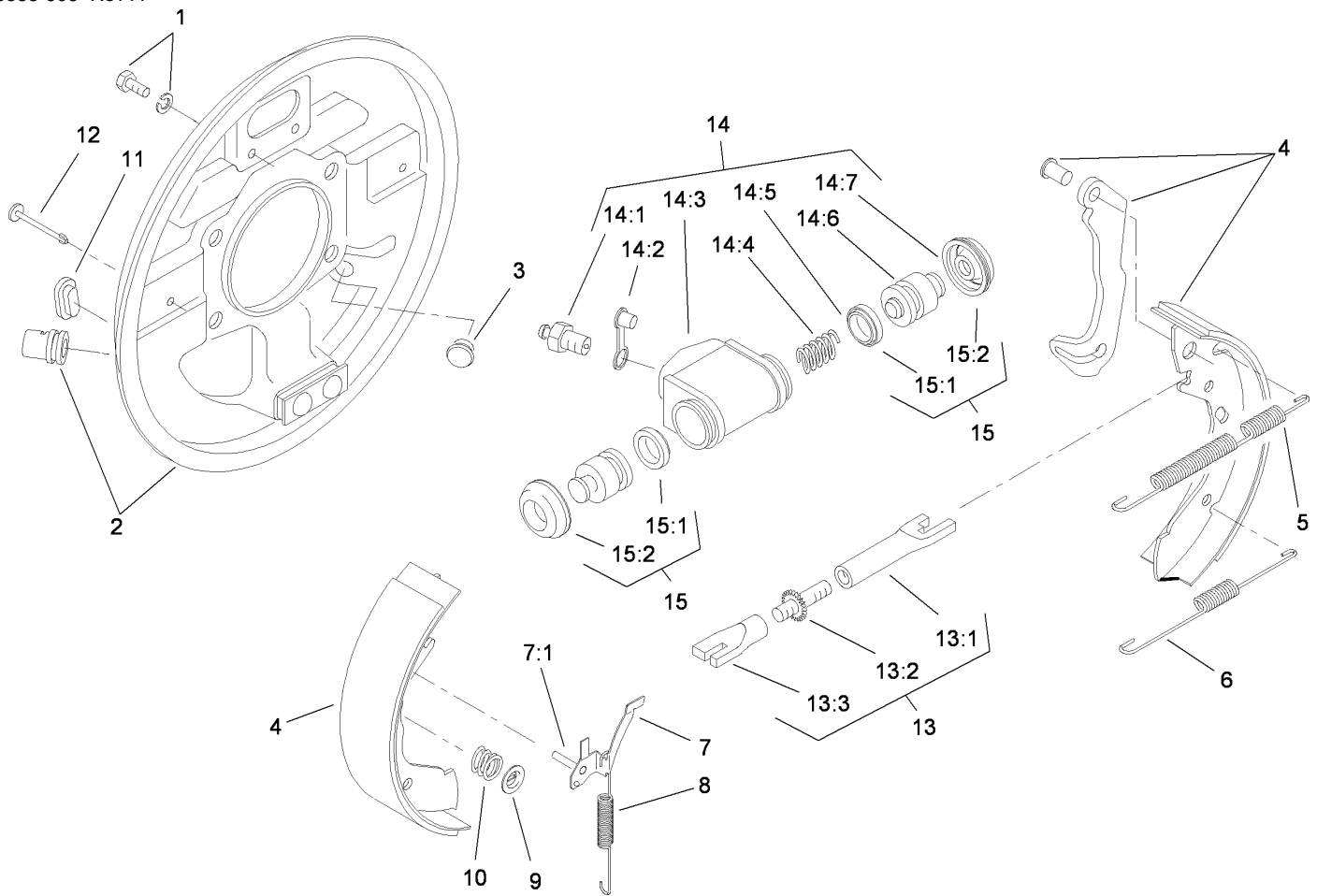

RH Rear Brake Assembly No. 112-7962

Ref	Part No.	Qty.	Description
1	92-4135	2	Bolt-Set
2	112-7967	1	Backing-Plate, RH
3	92-4146	1	Plunger ASM
4	112-7978	1	Lined Shoe Kit
5	92-4148	1	Spring-Return, Shoe (Upper, RH)
6	92-4149	1	Spring-Return, Shoe (Lower)
7	92-4124	1	RH Pawl Lever ASM
7:1		1	Pin-Pawl
8	92-4151	1	Spring-Adjuster, RH
9	92-4131	2	Washer-Hold Down, Shoe
10	92-4152	2	Spring-Hold Down, Shoe
11	92-4134	1	Plug-Inspection
12	92-4133	2	Pin-Hold Down, Shoe
13	92-4145	1	RH Adjustor ASM
13:1		1	Pushrod-Female
13:2		1	Bolt-Adjuster
13:3		1	Sleeve-Adjuster
14	92-4141	1	RH Wheel Cylinder ASM
14:1	92-4137	1	Screw-Bleed
14:2	92-4114	1	Cap-Screw, Bleed
14:3		1	Body
14:4		1	Spring
14:5		2	Seal-L Type
14:6		2	Piston

Ref	Part No.	Qty.	Description
14:7		2	Cover-Dust
15	92-4142	1	Seal Kit
15:1		2	Seal-L Type
15:2		2	Cover-Dust

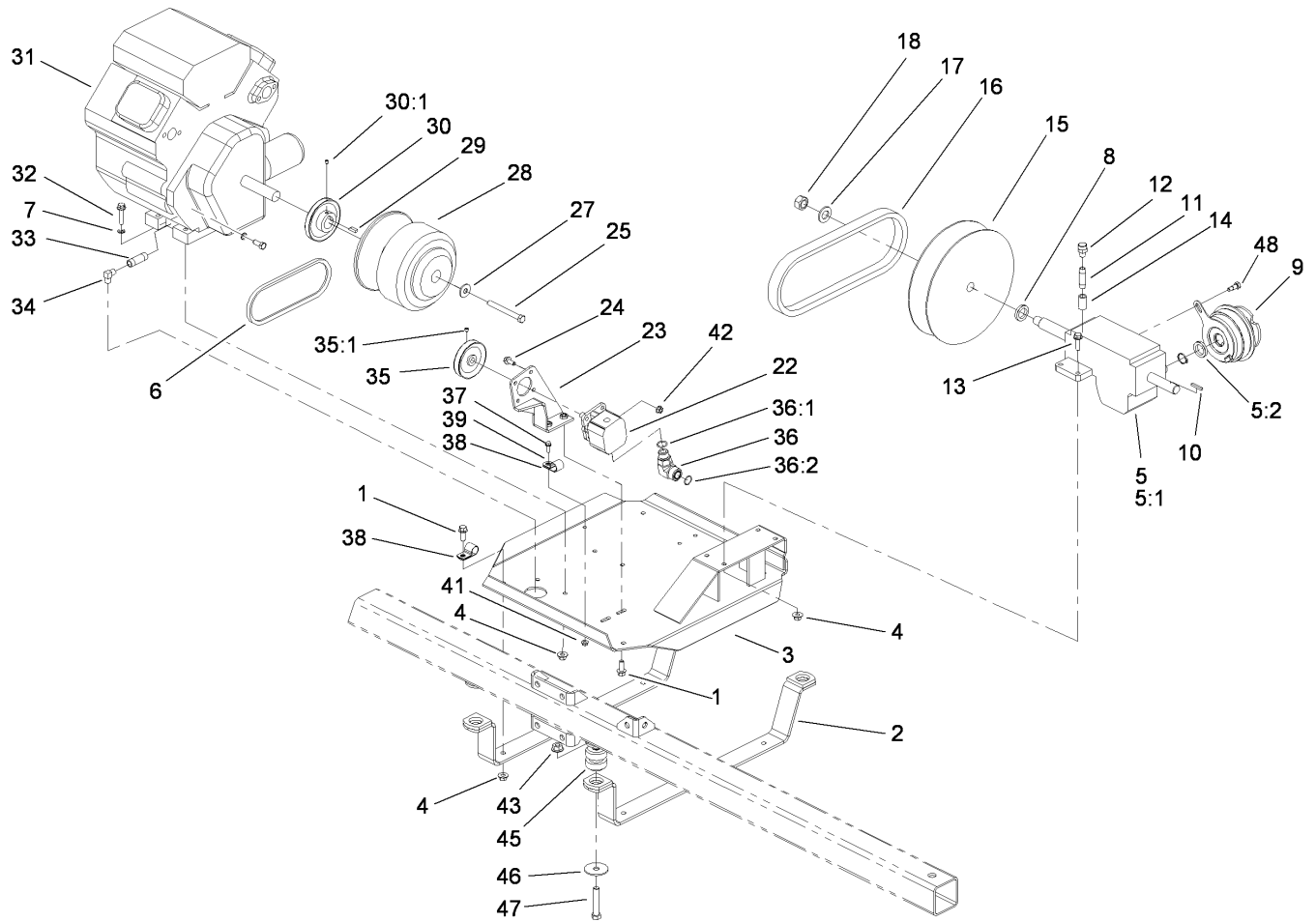

Engine and Gearbox Assembly

Ref	Part No.	Qty.	Description
1	3234-11	6	Screw-HHF
2	100-8377-03	2	Strap-Support, Engine
3	100-8357-03	1	Plate-Mounting, Engine
4	32128-43	12	Nut-Flange
5	108-3352	1	Pump Drive Gearbox ASM
5:1		1	Gearbox-Drive, Pump
5:2	108-3301	1	Retainer-Spacer
6	100-8372	1	Belt-Steering
7	3255-9	1	Washer-Lock
8	100-8390	1	Spacer
9	100-8290	1	Clutch-Electric, Pump (Drive)
10	92-0049	1	Key-Square
11	106-4869	1	Pipe-Coupling
12	100-6931	1	Breather
13	3234-24	4	Screw-HHF
14	104-8766	1	Nipple
15	100-8289	1	Drive Pulley ASM
16	108-3566	1	Belt
17	3256-28	1	Washer-Flat
18	100-8486	1	Nut-Locking, LH
22	100-8302	1	Pump-Steering
23	100-8368-03	1	Bracket-Pump, Steering
24	322-4	4	Screw-HH
25	3212-16	1	Screw-HH

Ref	Part No.	Qty.	Description
27	710128	1	Washer
28	100-8288	1	Clutch-Driver
29	100-8260	1	Key-Shaft
30	92-0488	1	Pulley-Pump
30:1	3246-2	2	Screw-Set, HSH
31		1	Engine-Kohler, Ch20S-64647
32	3234-19	4	Screw-HHF
33	92-3647	1	Nipple
34	95023	1	Elbow-90 DEG
35	100-8371	1	Pulley-Pump
35:1	3246-2	2	Screw-Set, HSH
36	340-16	1	Fitting-HYD, 90 DEG
36:1	237-80	1	O-Ring
36:2	237-58	1	O-Ring
37	3234-4	1	Screw-HHF
38	2412-81	3	Clamp-R
39	3256-22	1	Washer-Flat
41	32128-33	1	Nut-HF
42	32128-20	4	Nut-HF
43	32128-49	4	Nut-HHF
45	106-7865	4	Engine Mount ASM
46	41985	4	Washer-Special
47	325-11	4	Screw-HH
48	59-5400	1	Bolt-Shoulder

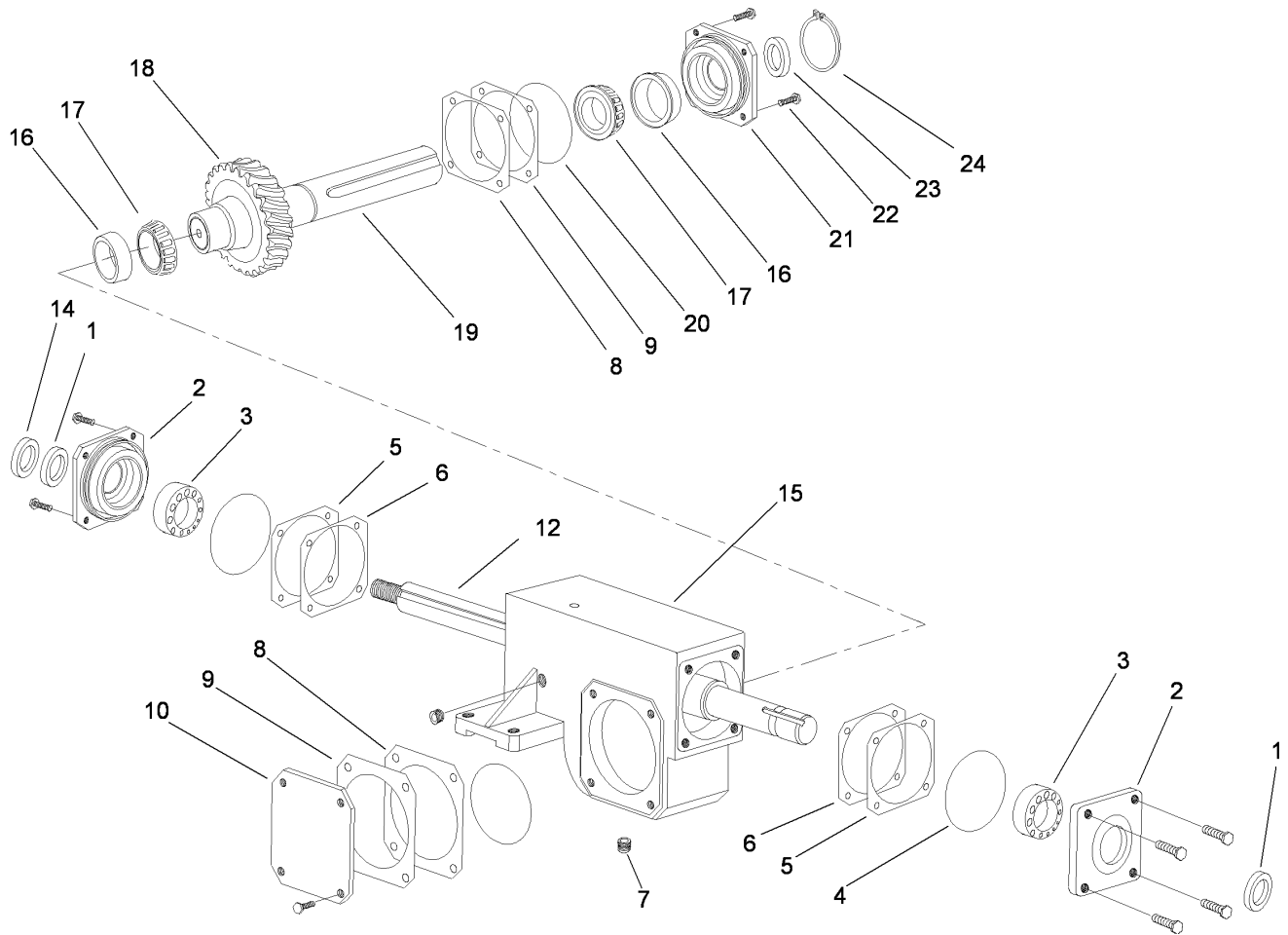

Pump Drive Gearbox Assembly No. 108-3352

Ref	Part No.	Qty.	Description
1	100-6929	2	Seal
2	100-6930	2	Cap-Open
3	251-348	2	Bearing-Ball
4	100-6932	2	O-Ring
5	100-6933	2	Shim-Red, .002
6	100-6934	2	Shim-Blue, .005
7	281-10	3	Plug
8	100-6936	2	Shim-Blue, .005
9	100-6937	2	Shim-Red, .002
10	100-6938	1	Cap-Closed
12	100-6940	1	Shaft-Worm
14	100-8390	1	Spacer
15		1	Housing-Gearbox
16	254-72	2	Bearing-Cup, Tapered
17	254-94	2	Bearing-Cone, Tapered
18	100-6944	1	Gear-Worm, S/1
19	100-6946	1	Shaft-Output
20	237-161	2	O-Ring
21	100-6948	1	Cap-Open
22	321-3	16	Screw-HH
23	104-8764	1	Seal-Viton
24	108-3302	1	Ring-Snap

--	--	--	--

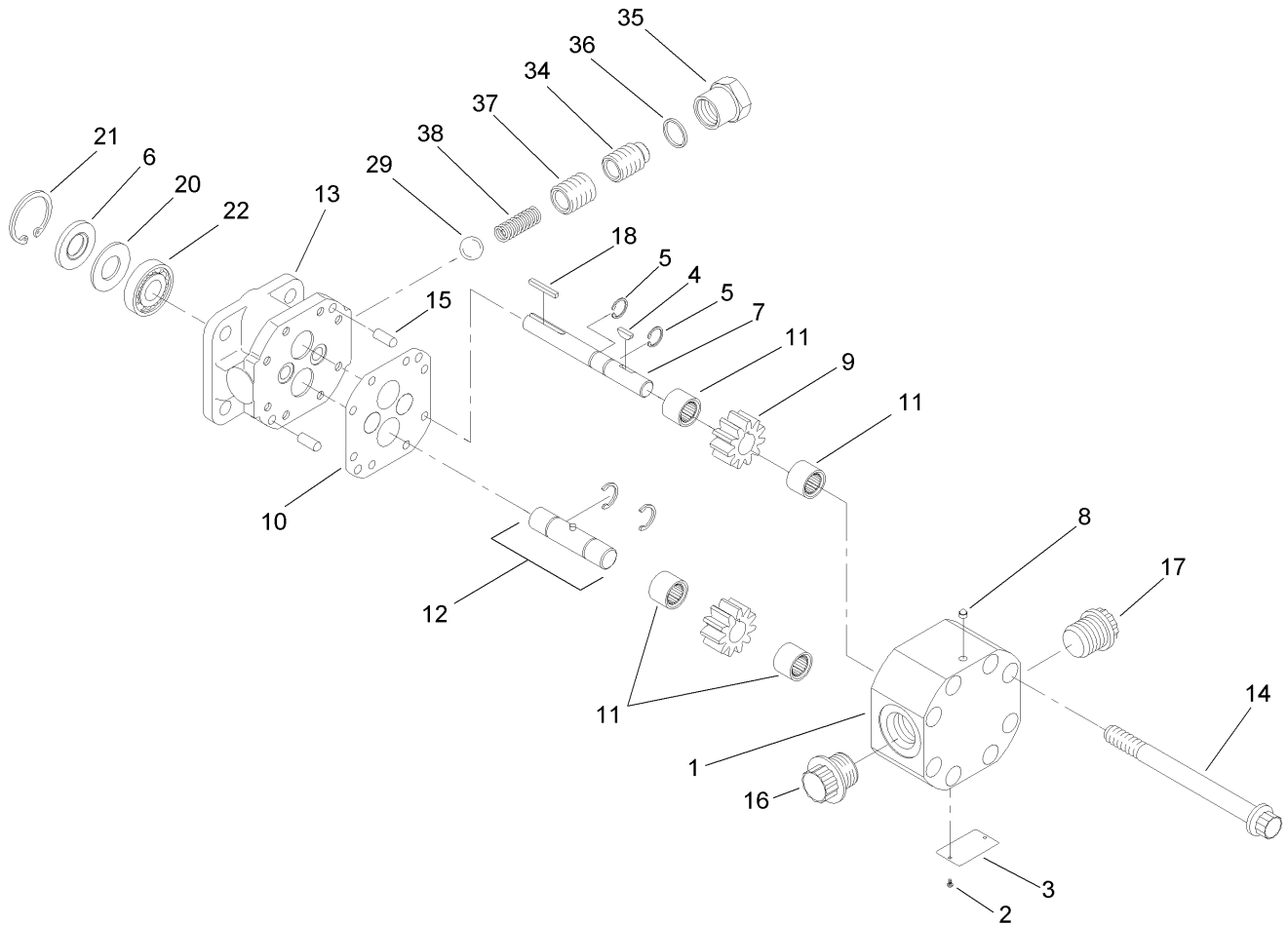

Steering Pump Assembly No. 100-8302

Ref	Part No.	Qty.	Description
1		1	Housing
2		2	Screw
3		1	Plate-Name
4	100-8270	1	Key
5	92-3961	2	Ring-Retaining
6	100-8275	1	Seal
7	106-6852	1	Shaft-Drive
8	100-8269	1	Plug-Beta
9	106-6853	1	Gear
10	106-6854	1	Gasket Kit
11	106-6855	4	Bearing-Needle
12		1	Shaft-Idler
13		1	Stator
14	100-8268	8	Screw
15	92-2176	2	Pin-Shear
16		1	Plug
17		1	Plug
18	92-3876	1	Key-Shaft
20	92-2186	1	Spacer
21	92-3873	1	Ring-Retaining
22	92-2191	1	Bearing-Ball
29	100-8273	1	Ball-Steel
34	100-8272	1	Screw
35	92-2184	1	Cap-Hex, Relief Valve

Ref	Part No.	Qty.	Description
36	92-2180	1	Gasket-Copper
37	92-3870	1	Spring
38	92-3871	1	Spring

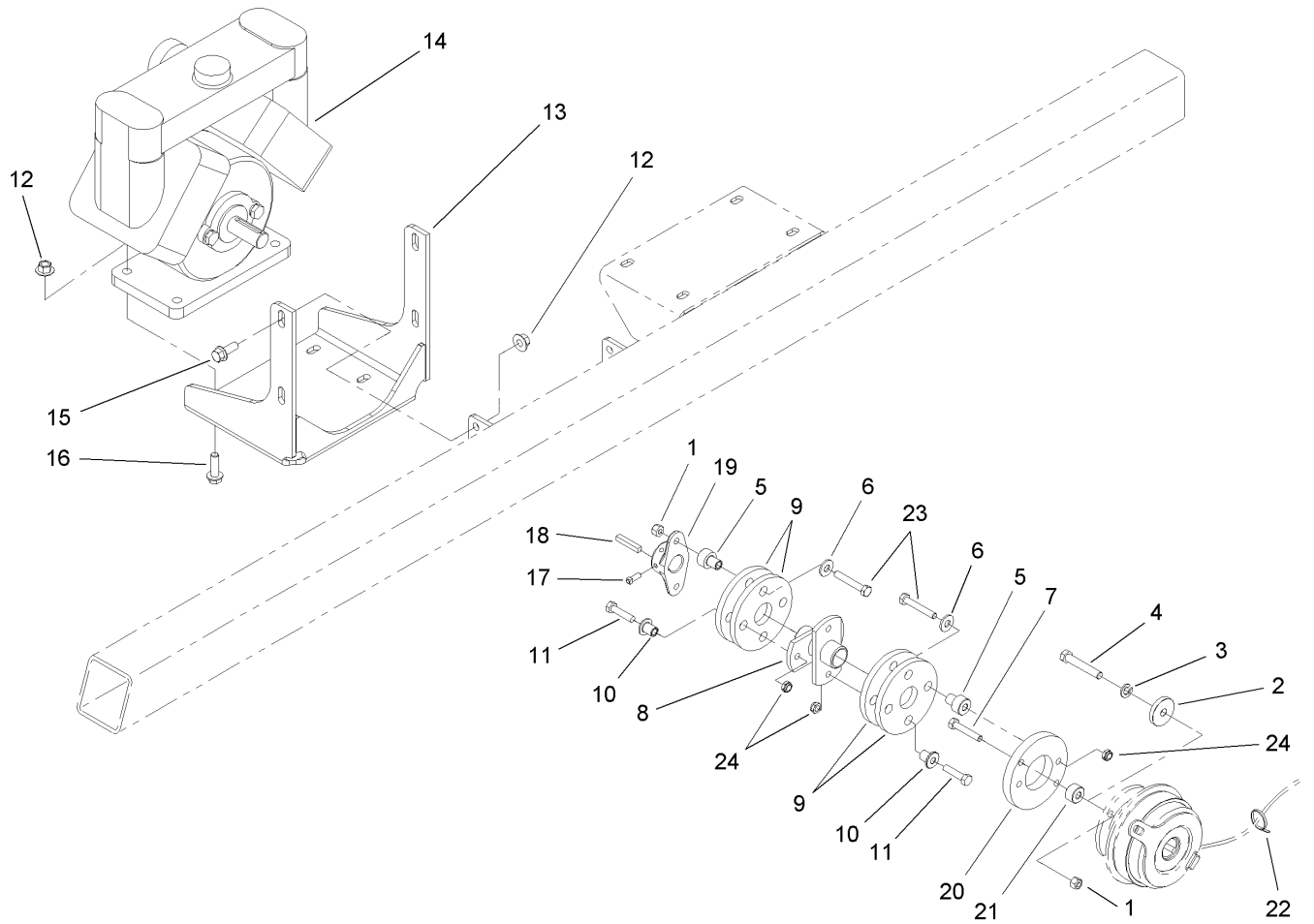

Pump Assembly

Ref	Part No.	Qty.	Description
1	3296-29	4	Nut-Lock, NI
2	100-8391	1	Retainer-Clutch, Electric
3	3253-5	1	Washer-Lock
4	3211-10	1	Screw-HH
5	71-4410	4	Spacer
6	3256-3	4	Washer-Flat
7	322-9	2	Screw-HH
8	107-8750-03	1	Drive-Coupler
9	44-2230	4	Coupling-Rubber
10	71-4411	4	Spacer
11	322-17	4	Screw-HH
12	32128-43	8	Nut-Flange
13	107-8622-03	1	Mount-Pump
14	106-5121	1	Pump
15	3234-11	4	Screw-HHF
16	3234-24	4	Screw-HHF
17	3241-5	2	Screw-Set
18	5-7280	1	Key
19	110-5227	1	Hub-Pump
20	100-8435	1	Adapter-Clutch
21	104-8763	2	Spacer
22	3290-379	4	Tie-Cable
23	322-10	4	Screw-HH
24	99-6007	6	Nut-Lock, NI

--	--	--	--

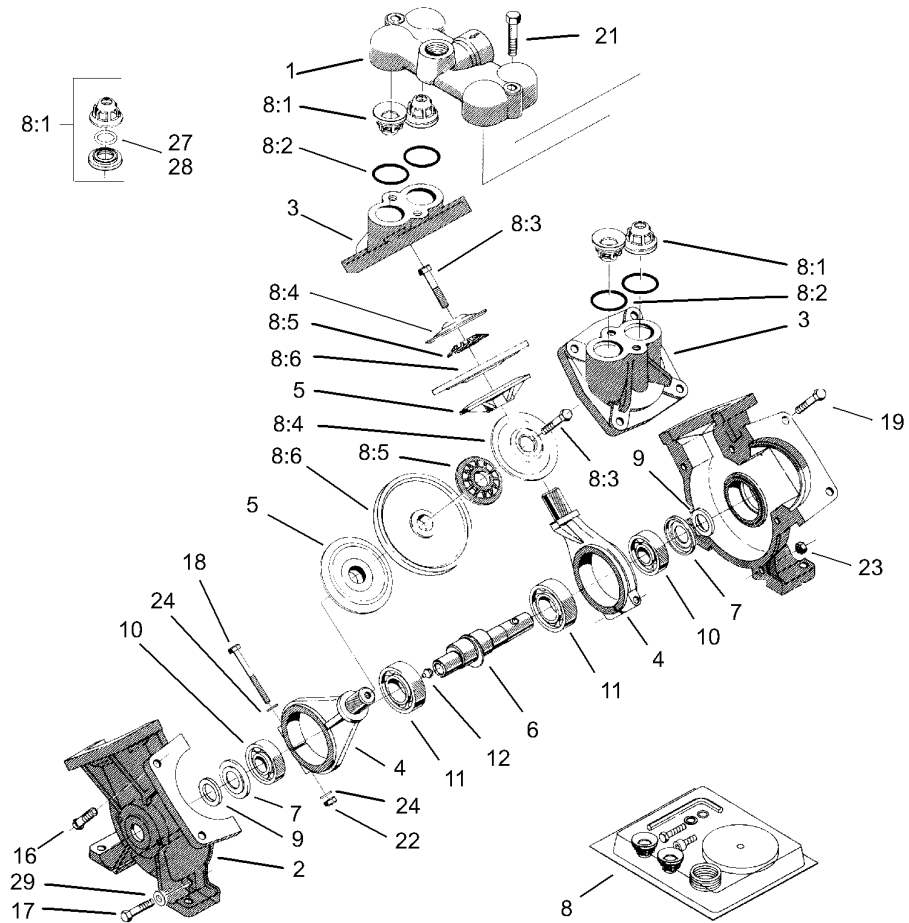

Pump Assembly No. 106-5121

Ref	Part No.	Qty.	Description
1	106-5139	1	Cover-Valve
2	106-5140	2	Housing-Pump
3	106-5141	2	Cover-Diaphragm
4	106-5142	2	Rod-Connecting
5	100-8314	2	Disc-Back, Diaphragm
6	104-9052	1	Crankshaft-Keyed
7	100-8325	2	Plate-Dust
8	106-5150	1	Repair Kit
8:1	100-8307	4	Valve
8:2	100-6652	4	Gasket
8:3	106-5147	2	Bolt
8:4	100-8311	2	Washer
8:5	100-8312	2	Washer-Nylon
8:6	100-8313	2	Diaphragm
9	99-0868	2	Felt-Seal
10	100-8327	2	Bearing-Ball
11	100-8329	2	Bearing-Ball
12	99-0873	1	Fitting-Grease
16	106-5143	3	Bolt
17	106-5144	2	Bolt
18	106-5145	2	Bolt
19	106-5146	8	Bolt
21	106-5148	2	Bolt
22	100-8326	2	Nut-Hex

Ref	Part No.	Qty.	Description
23	106-5149	5	Nut
24	100-8316	4	Washer-Lock
27	100-8336	4	O-Ring
28	106-5138	4	O-Ring
29	106-5137	2	Washer

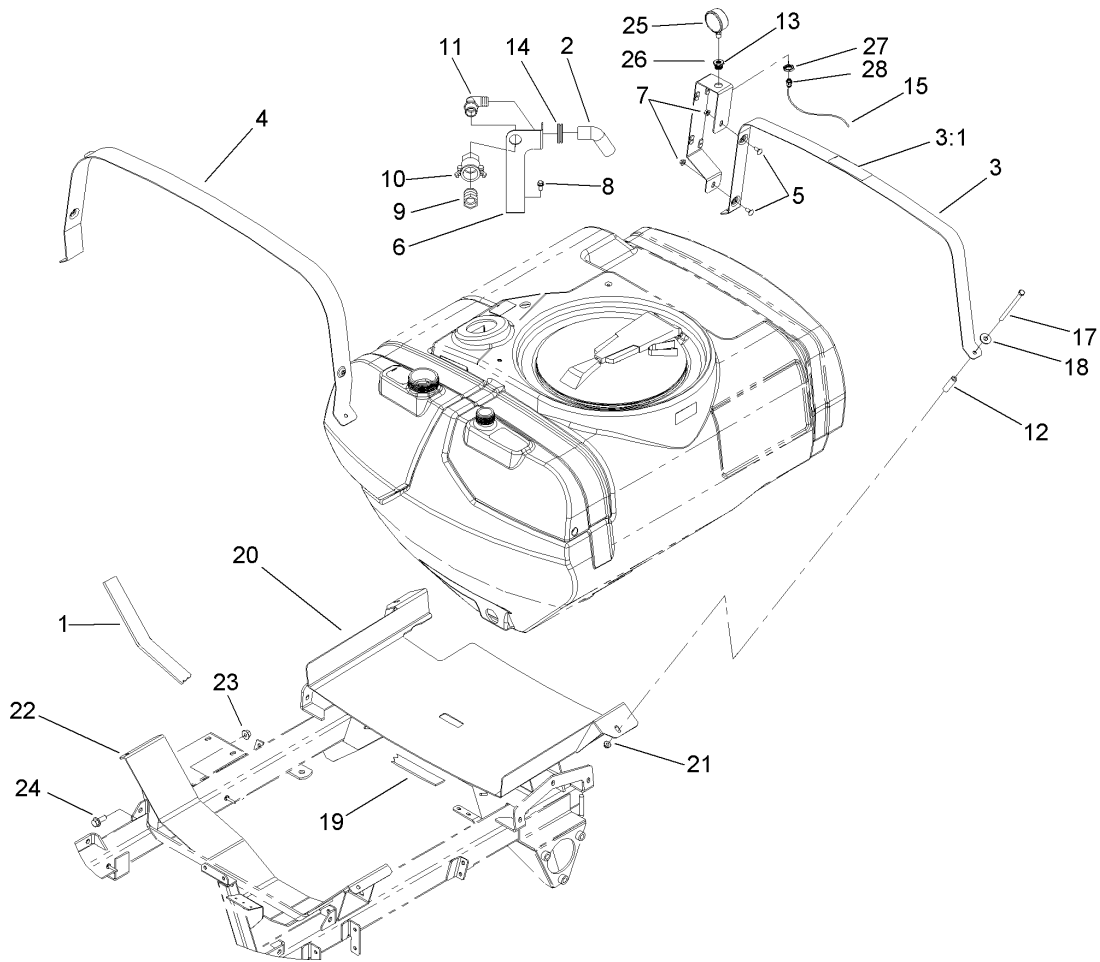

Tank and Saddle Assembly

Ref	Part No.	Qty.	Description
1	100-8573	2	Foam-Saddle, Front
2	110-5088	1	Hose-Fill
3	106-5048	1	Tank Band ASM
3:1	106-5016	1	Decal-Caution, Electric Shock
4	106-5063-03	1	Band-Tank, Front
5	3230-1	2	Bolt-CARR
6	110-5082-03	1	Bracket-Anti-Siphon
7	32128-20	2	Nut-HF
8	3234-5	1	Screw-HHF
9	41316	1	Adapter-Quick
10	100-6779	1	Coupling-Female
11	41140	1	Elbow
12	99-7375	1	Hose-Breather
13	112-7946-03	1	Tee-Bracket, Mounting
14	110-5090	1	Grommet
15	104-8782	1	Tube-Gauge, Pressure
17	323-58	4	Bolt-TAP, HH
18	94-2701	4	Washer-Hardened
19	100-8574	3	Foam-Saddle, Right Rear
20	108-3356-03	1	Rear Saddle ASM
21	104-8301	4	Nut-Flange, NI
22	100-8565-03	1	Front Saddle ASM
23	32128-49	4	Nut-HHF
24	3234-32	4	Screw-HHF

Ref	Part No.	Qty.	Description
25	110-5080	1	Gauge-Pressure
26	100-8665	1	Reducer-Gauge, Pressure
27	100-8666	1	Nut-Reducer
28	100-8667	1	Coupler-Reducer

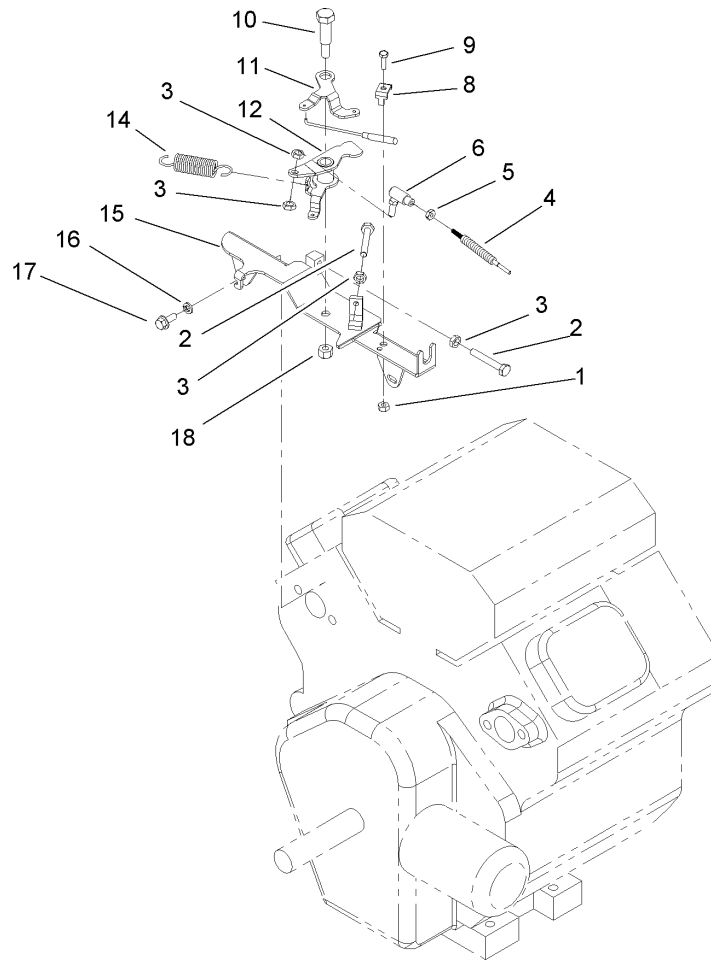

Throttle Linkage Assembly

Ref	Part No.	Qty.	Description
1	3296-2	1	Nut-Lock
2	108-3660	2	Screw-TAP
3	3220-1	4	Nut-Jam
4	100-8383	1	Cable-Accelerator
5	3219-14	1	Nut-Hex
6	100-8559	1	Ball Joint ASM
8	92-0477	1	Clamp-Cable
9	3290-134	1	Screw
10	7-0030	1	Bolt-Shoulder
11	87-7790	1	Lever-Choke
12	100-8558	1	Lever-Throttle
14	67-1450	1	Spring-Idler
15	100-8557	1	Lever-Throttle
16	48-8020	4	Washer-Spring
17	33103-016	4	Screw-HHF
18	3296-29	1	Nut-Lock, NI

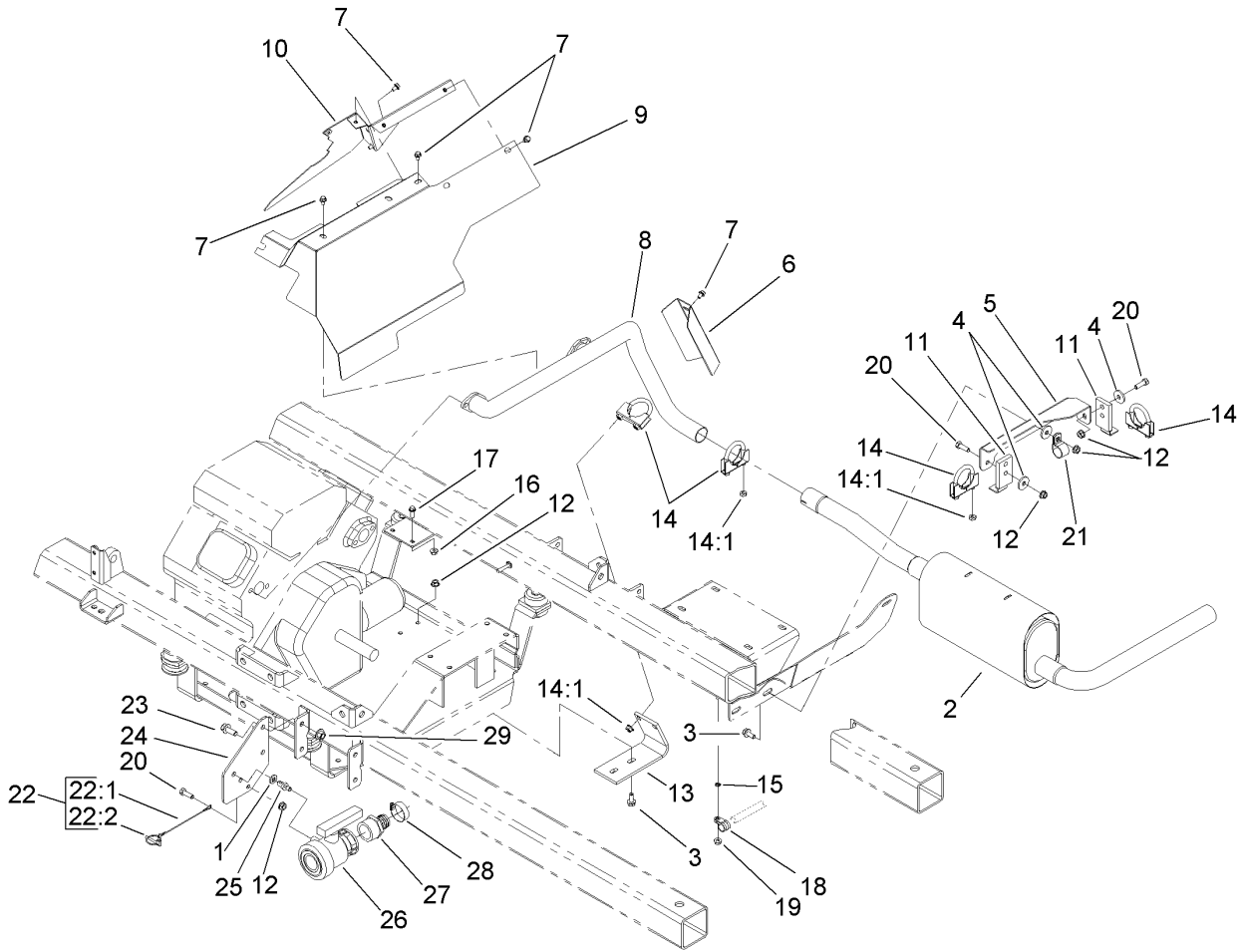

Exhaust Assembly

Ref	Part No.	Qty.	Description
1	62-1230	2	Washer-Rubber
2	110-5119	1	Muffler Tailpipe ASM
3	3234-5	4	Screw-HHF
4	356303	4	Washer
5	108-3678-03	1	Bracket-Muffler
6	100-8409-03	1	Shield-Exhaust, Lower
7	3234-26	10	Screw
8	100-8291	1	Header Pipe ASM
9	100-7028-03	1	Shield-Heat, Upper
10	100-7029-03	1	Shield-Heat, Mid
11	108-3690	2	Hanger-Muffler
12	32128-20	7	Nut-HF
13	112-7944	1	Support-Header
14	2112-9	4	Clamp
14:1	32128-20	2	Nut-HF
15	3255-7	1	Washer-Lock / EXT
16	32128-33	2	Nut-HF
17	3234-4	2	Screw-HHF
18	2412-134	1	R-Clamp
19	32128-33	1	Nut-HF
20	322-5	3	Screw-HH
21	2412-39	1	R-Clamp
22	98-0979	1	Lynch Pin ASM
22:1	28-8070	1	Lanyard

Ref	Part No.	Qty.	Description
22:2	3290-495	1	Pin-Klik
23	3234-11	2	Screw-HHF
24	110-5222-03	1	Mount-Valve
25	112-7900	2	Mount-Peg
26	108-0069	1	Valve-Ball
27	110-5224	1	Fitting-Barbed, Straight
28	2412-34	1	Clamp-Hose
29	32128-43	2	Nut-Flange

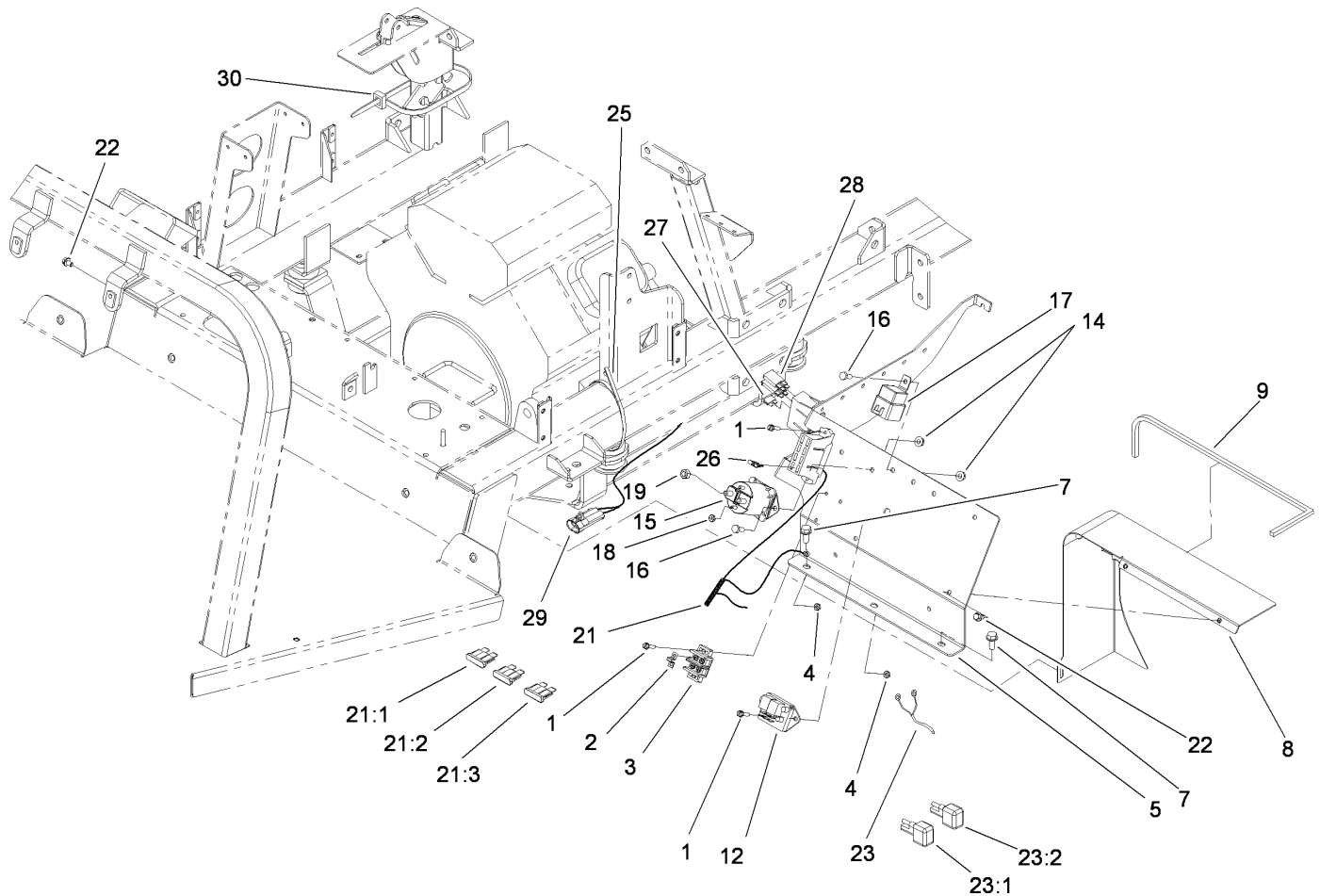

Electrical Panel Assembly

Ref	Part No.	Qty.	Description
1	32105-13	6	Screw-HWH
2	42863	1	Strip-Jumper
3	42862	1	Block-Terminal, Ground
4	3296-2	6	Nut-Lock
5	108-3676-03	1	Panel-Electrical
7	32144-70	3	Screw-HWHTF
8	100-7025-03	1	Shield-Heat, Front
9	100-7027	1	Trim
12	99-3703	1	Module-Cruise
14	32128-33	8	Nut-HF
15	99-7406	1	Solenoid
16	321-3	8	Screw-HH
17	99-7430	7	Relay
18	3219-14	2	Nut-Hex
19	3217-6	2	Nut-Hex
21	108-9461	1	Harness-Wire, Main
21:1	110928	1	Fuse-5 Amp
21:2	218-578	1	Fuse-10 Amp
21:3	109103	1	Fuse-30 Amp
22	3234-26	3	Screw
23	108-3662	1	Harness-Wire, Sprayer
23:1	100-4918	2	Diode
23:2	108-9493	2	Diode-Tvs
25	3290-379	4	Tie-Cable

Ref	Part No.	Qty.	Description
26	109101	1	Fuse-20 Amp
27	109355	1	Fuse-15 Amp
28	108-3736	2	Breaker-Circuit, 30A
29	108-9470	1	Harness-Wire, Fusible Link
30	3290-379	1	Tie-Cable

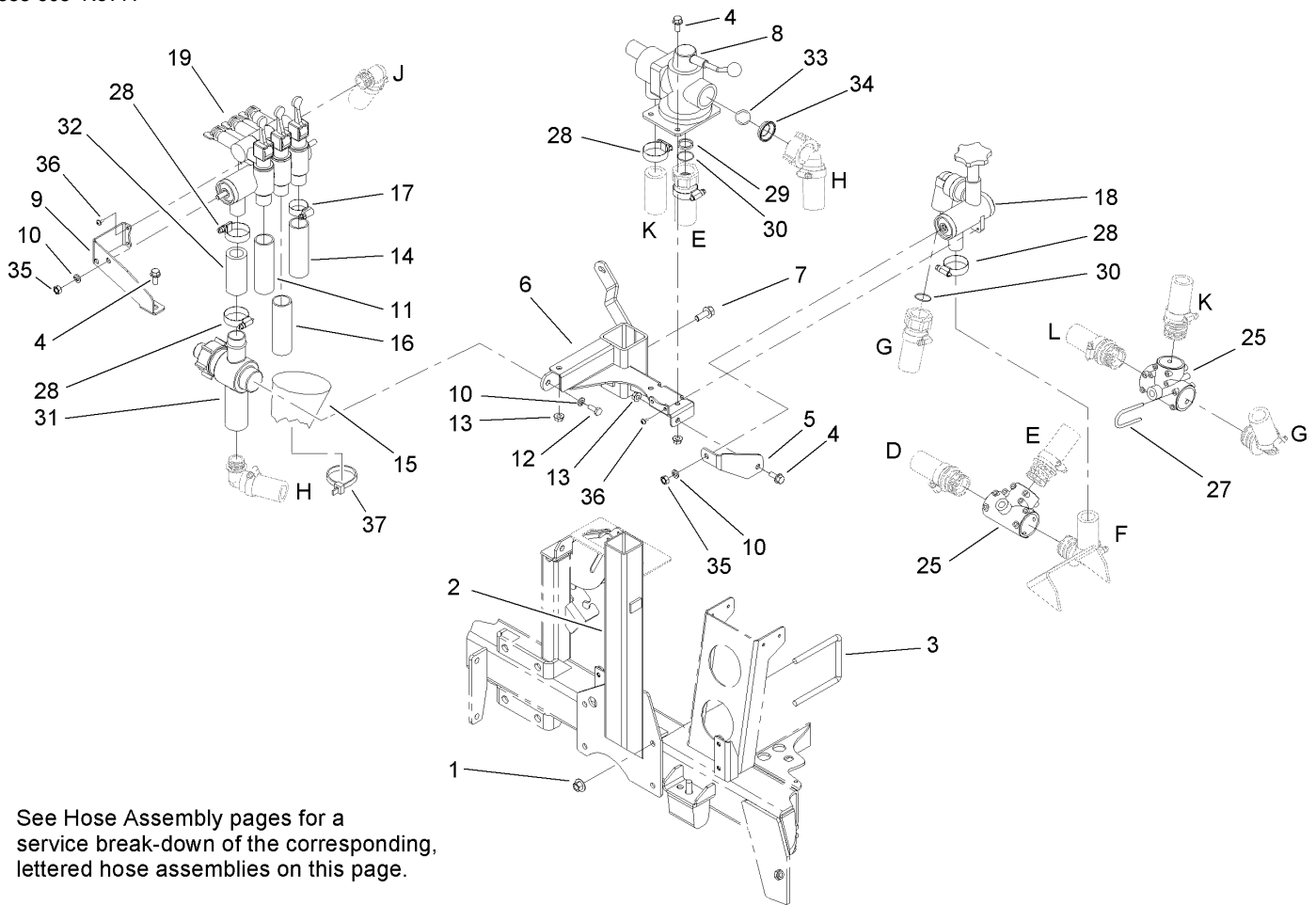

See Hose Assembly pages for a service break-down of the corresponding, lettered hose assemblies on this page.

Manual Control Assembly

Ref	Part No.	Qty.	Description
1	32128-43	4	Nut-Flange
2	104-8828-03	1	Valve-Post
3	100-7067	2	U-Bolt
4	3234-5	4	Screw-HHF
5	104-8838-03	1	Bracket-Valve, Rate
6	104-8833-03	1	Mount-Valve
7	3234-11	1	Screw-HHF
8	106-4881	1	Main On/Off Valve ASM
9	104-8839-03	1	Bracket-Valve, Section
10	3253-4	4	Washer-Lock
11	108-3740	1	Hose-Boom, RH
12	33114-020	1	Screw-HH
13	32128-20	4	Nut-HF
14	108-3741	1	Hose-Boom, LH
15	106-6713	2	Cover-Lines, Steering
16	108-3739	1	Center Boom Hose
17	2412-129	3	Clamp-Hose
18	106-4883	1	Pressure Control Valve ASM
19	106-4882	1	Boom Valve ASM
25	104-9041	2	Tee
27	100-6708	6	Fork
28	2412-34	4	Clamp-Hose
29	106-4897	1	Support-O Ring
30	100-6655	2	Gasket

Ref	Part No.	Qty.	Description
31	106-4884	1	Flow Meter ASM
32	104-8905	1	Hose-Pressure
33	100-7000	1	Ball-Plastic
34	100-6999	1	Bushing
35	100-6894	4	Nut
36	100-6916	4	Screw-Plastic
37	3290-379	4	Tie-Cable

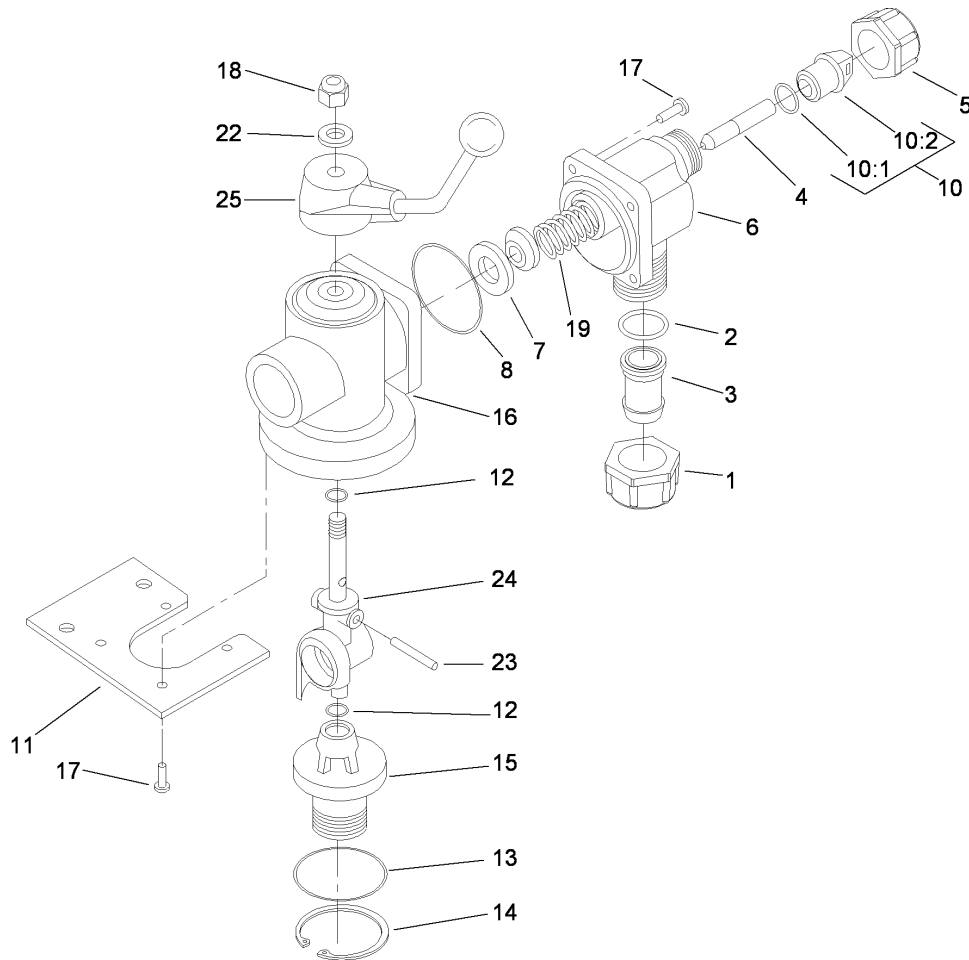

Main On/Off Valve Assembly No. 106-4881

Ref	Part No.	Qty.	Description
1	99-0769	1	Nut
2	100-6655	1	Gasket
3	99-0781	1	Hosebarb
4	100-6942	1	Pin
5	99-0850	1	Nut
6	100-6943	1	Housing-Valve, Pressure
7	100-6945	1	Seat
8	100-6947	1	O-Ring
10	99-0844	1	Plug-Tube, Nozzle
10:1	100-6645	1	O-Ring
10:2	100-6941	1	Fitting
11	100-6997	1	Fitting
12	100-6641	2	O-Ring
13	100-6993	1	O-Ring
14	100-6994	1	Ring-Snap, Inner
15	100-6951	1	Adapter-Valve, On/Off
16	100-6949	1	Housing-Valve, On/Off (Manual)
17	100-6916	8	Screw-Plastic
18	48-9520	1	Nut
19	100-7003	1	Relief Valve ASM
22	99-0863	1	Washer
23	100-8656	1	Pin-Expansion
24	100-6950	1	Stem-Valve, On/Off (Manual)
25	100-7001	1	Handle

--	--	--	--

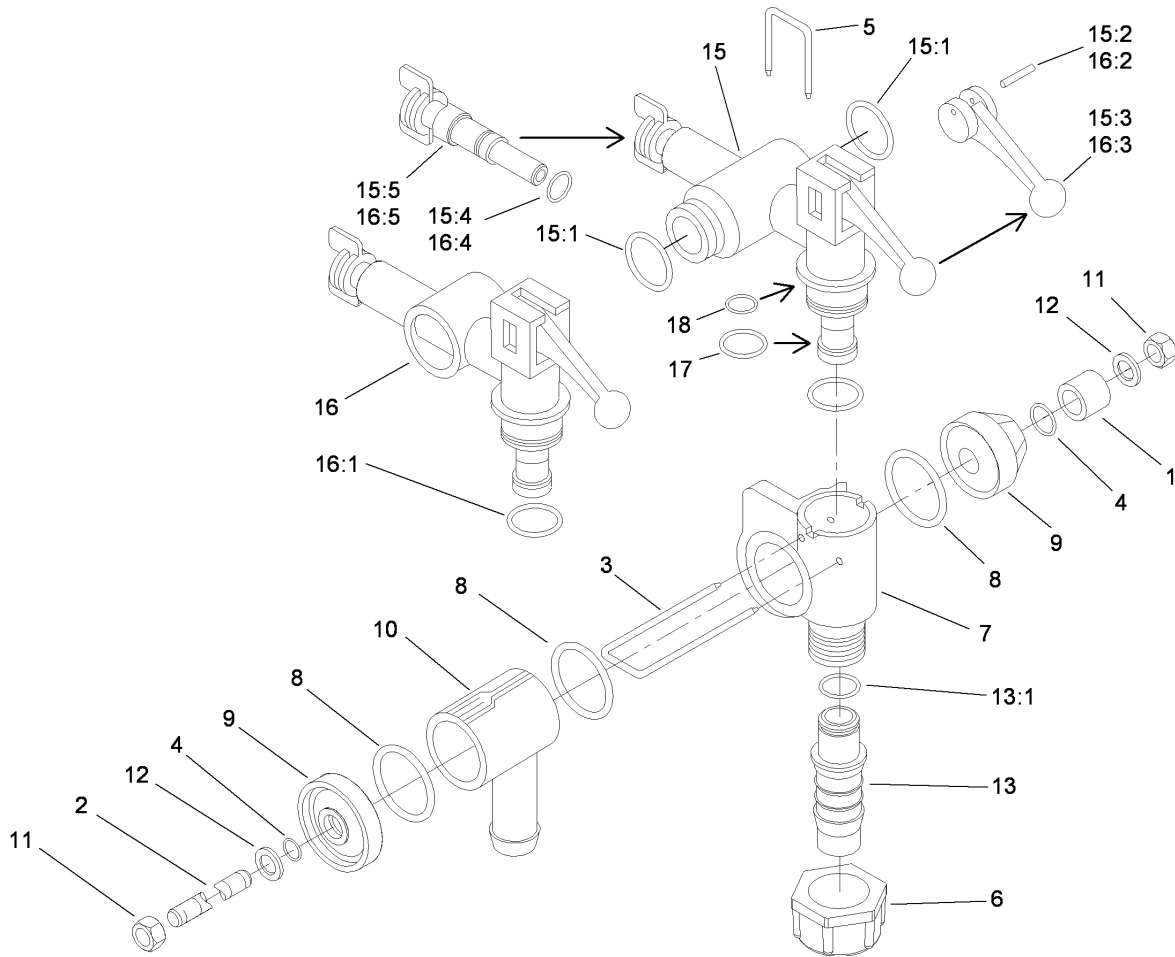

Boom Valve Assembly No. 106-4882

Ref	Part No.	Qty.	Description
1	100-6897	1	Bushing
2	104-8916	1	Rod-Valve, Individual Boom
3	100-6758	1	Fork
4	100-6887	2	O-Ring
5	100-6885	3	Fork-Valve, Boom
6	99-0850	3	Nut
7	100-6759	3	Housing-Section Valve
8	100-6892	5	O-Ring
9	100-6913	2	Cover
10	100-6908	1	T-Piece
11	100-6894	2	Nut
12	100-6634	2	Washer
13	106-5112	3	Hosebarb ASM
13:1	100-6645	1	O-Ring
15	100-6767	2	Valve-Boom Section, Manual
15:1	100-6882	1	O-Ring
15:2	100-6766	1	Pin
15:3	100-6835	1	Handle
15:4	100-6641	1	O-Ring
15:5	100-6769	1	Screw-Adjust
16	100-6765	1	Valve-Boom Section, Manual
16:1	100-6882	1	O-Ring
16:2	100-6766	1	Pin
16:3	100-6835	1	Handle

Ref	Part No.	Qty.	Description
16:4	100-6641	1	O-Ring
16:5	100-6769	1	Screw-Adjust
17	100-6770	2	O-Ring
18	100-6878	3	O-Ring

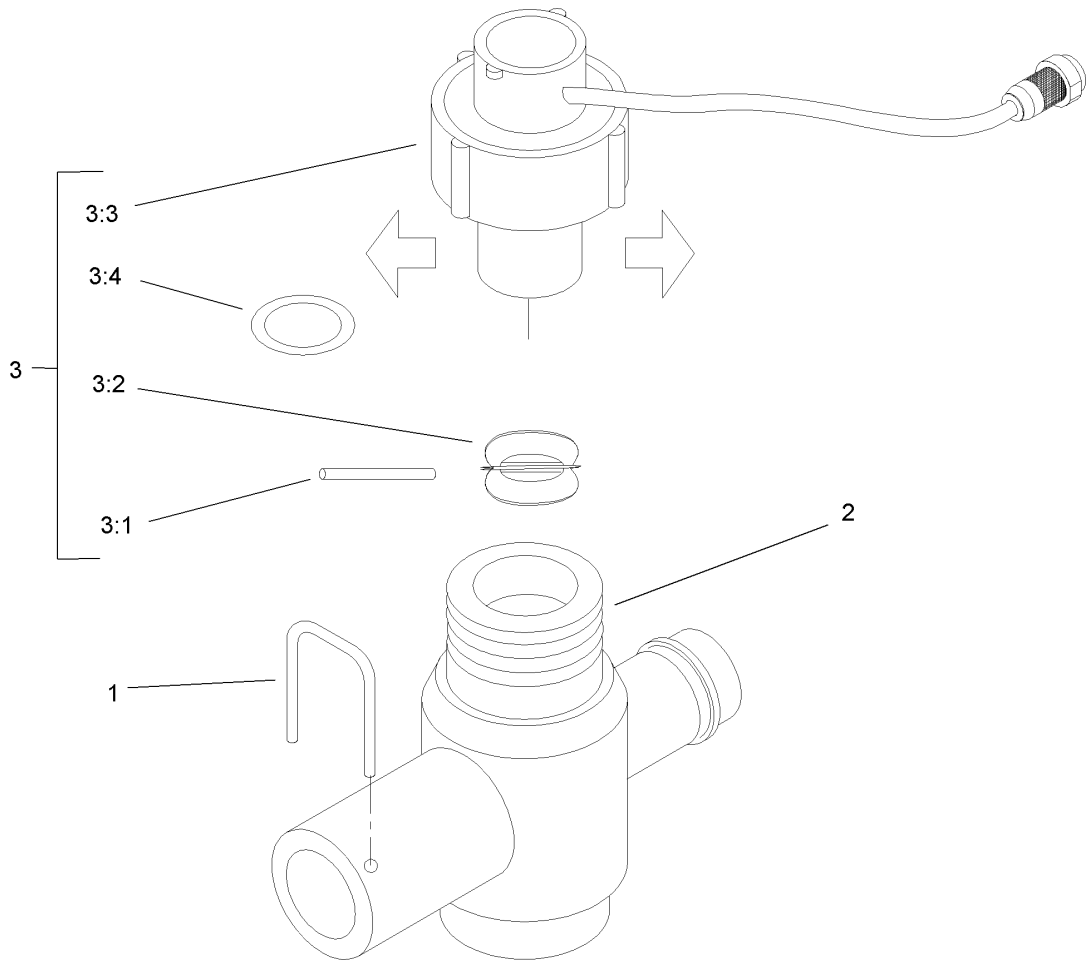

Flow Meter Assembly No. 106-4884

Ref	Part No.	Qty.	Description
1	100-6885	1	Fork-Valve, Boom
2	104-8901	1	Housing-Meter, Flow
3	100-6900	1	Flow Sensor ASM
3:1	100-6906	1	Shaft-Rotor
3:2	100-6919	1	Meter-Flow, Rotor
3:3	100-8678	1	Nut
3:4	100-8653	1	O-Ring

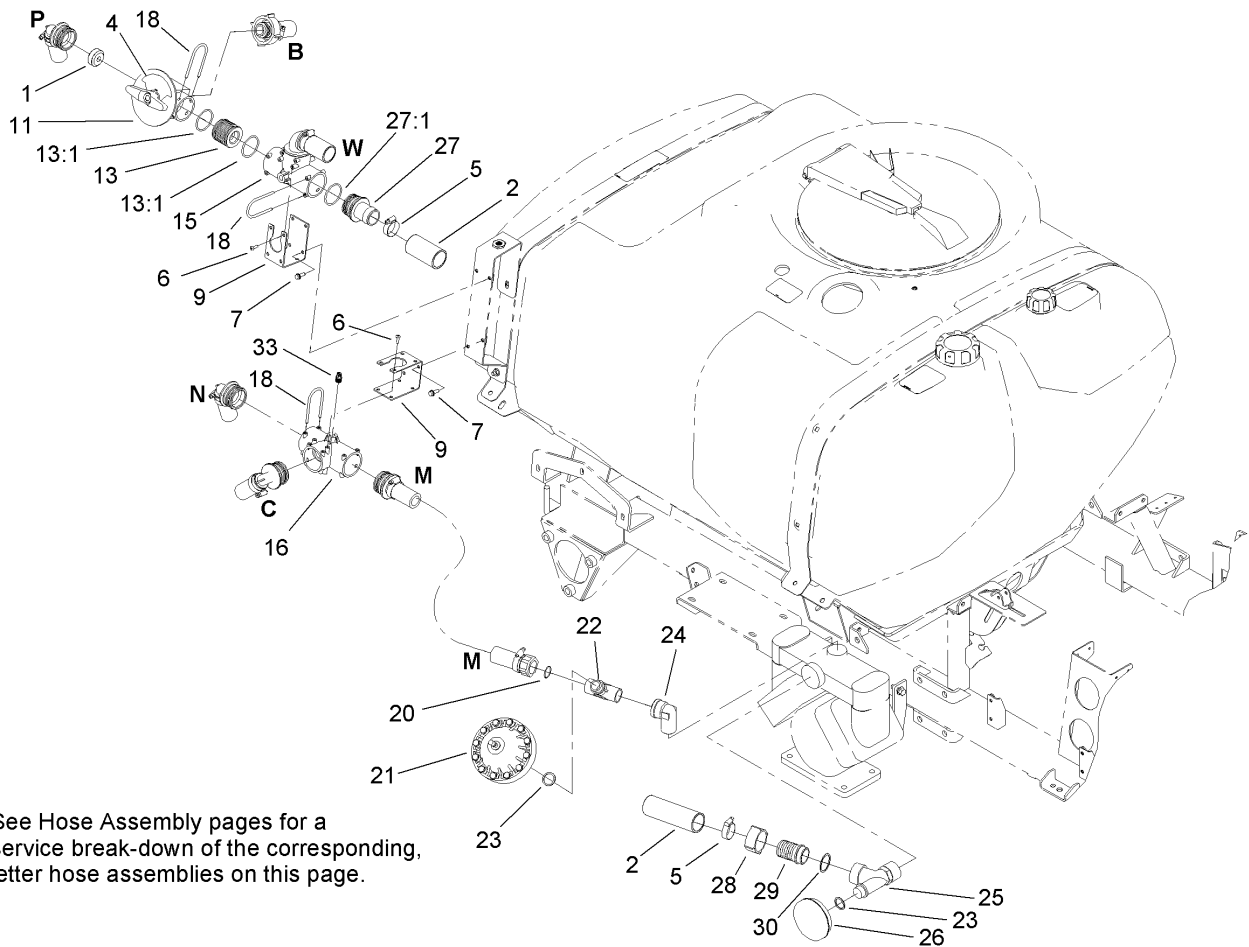

See Hose Assembly pages for a service break-down of the corresponding, letter hose assemblies on this page.

Sprayer Component Assembly No. 1

Ref	Part No.	Qty.	Description
1	110-5186	1	Reducer-Agitation
2	108-3686	1	Hose-Suction
4	107-8621	1	Decal-Agitation
5	41327	2	Clamp-Hose
6	32144-32	8	Screw
7	3234-4	4	Screw-HHF
9	100-8478	2	Bracket-Tee
11	100-8673	1	Agitation Valve ASM
13	106-4947	1	Connector
13:1	100-8637	2	O-Ring
15	100-6704	1	Tee
16	100-8675	1	Tee-Pressure
18	100-8635	8	Fork
20	100-6655	1	Gasket
21	100-6662	1	Damper-Pressure
22	100-8699	1	Tee
23	100-6656	2	O-Ring
24	100-8698	1	Elbow
25	100-8681	1	Tee
26	100-6660	1	Suction Damper ASM
27	106-4936	1	Hosebarb
27:1	100-8637	1	O-Ring
28	100-8678	1	Nut
29	100-8679	1	Hosebarb

Ref	Part No.	Qty.	Description
30	100-8680	1	Seal
33	100-8674	1	Coupler-Tube

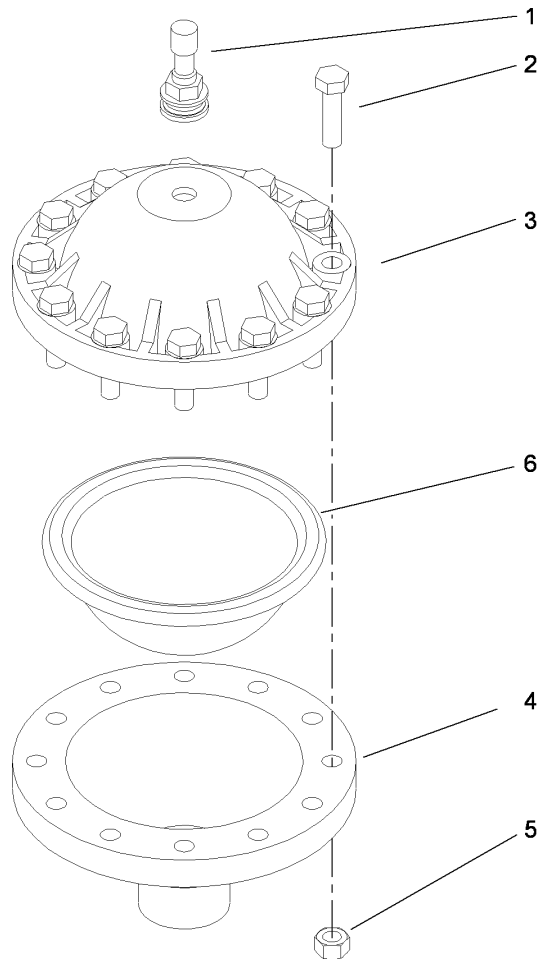

Pressure Damper Assembly No. 100-6662

Ref	Part No.	Qty.	Description
1	99-0895	1	Valve For Air-Pressure Damper
2	33114-030	12	Screw-HH
3	99-0896	1	Upper Half-Damper, Pressure
4	99-0898	1	Lower Half-Damper, Pressure
5	33014-00	12	Nut-Hex
6	99-0897	1	Diaphragm F. Pressure Damper

--	--	--	--

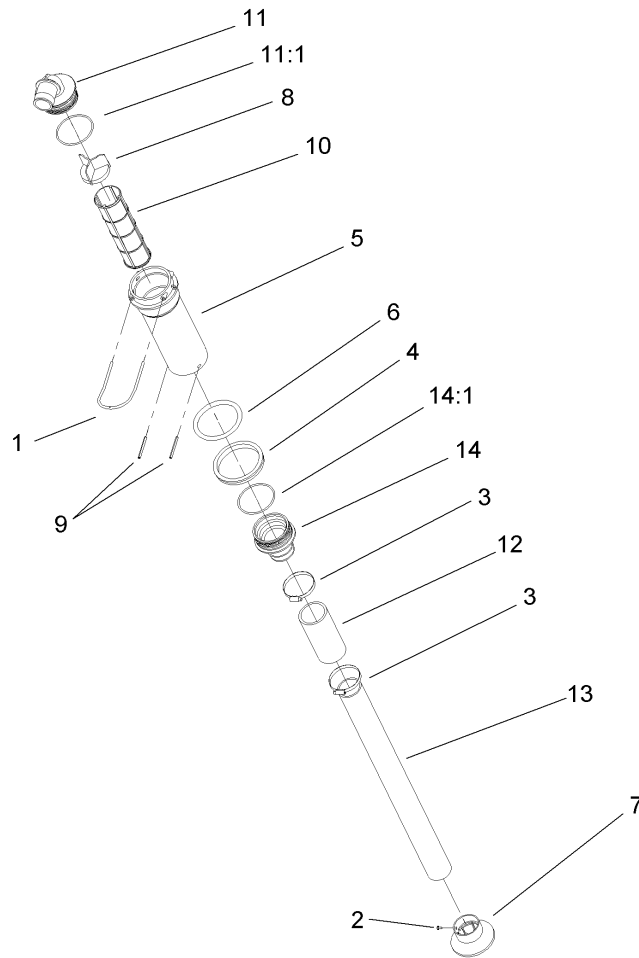

Top Mounted Suction Assembly

Ref	Part No.	Qty.	Description
1	100-8636	1	Fork-Special
2	108-3270	1	Screw-TAP
3	26392	2	Clamp-Hose
4	100-8647	1	Nut-Bulkhead
5	100-8643	1	Housing-Filter
6	100-8646	1	Gasket-Bulkhead
7	100-6714	1	Foot-Tube, Suction
8	100-8641	1	Vane-Screen
9	100-8644	2	Pin-Expansion
10	100-8642	1	Screen-Suction, Mesh 50
10	100-6991	1	Element-Filter, Green
10	100-6992	1	Element-Filter, Red
11	106-4952	1	Hosebarb-90 DEG
11:1	100-6989	1	O-Ring
12	100-8649	1	Hose-Suction
13	107-8625	1	Tube-Suction
14	106-4942	1	Hosebarb-Straight
14:1	100-8640	1	O-Ring

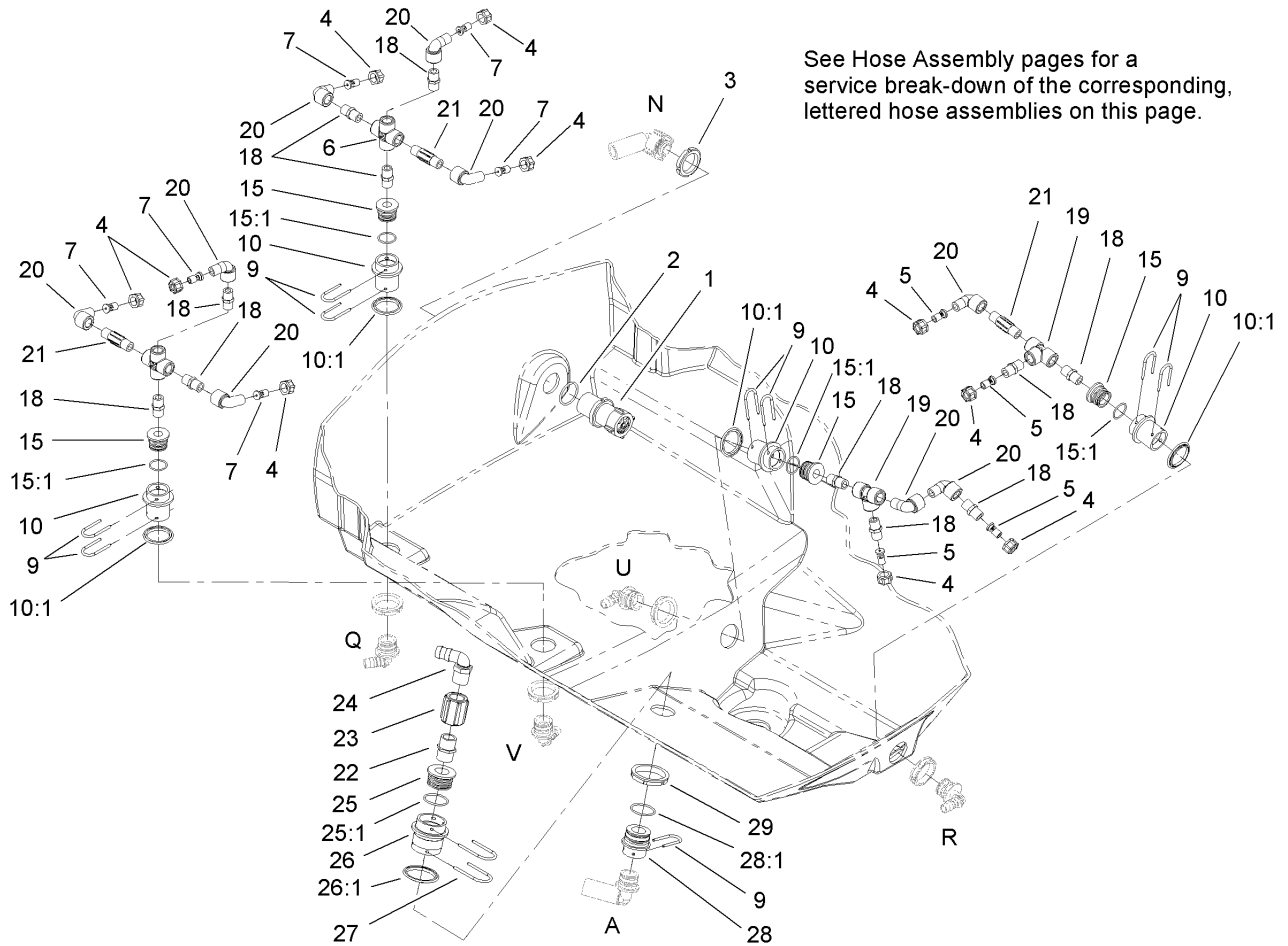

Sprayer Component Assembly No. 3

Ref	Part No.	Qty.	Description
1	100-6820	1	Valve-Safety, 225 Psi
2	100-6652	1	Gasket
3	99-0761	1	Ringnut
4	99-0766	10	Nut
5	100-6705	4	Nozzle-Agitation
6	110-5248	2	Cross
7	100-6706	6	Nozzle-Agitation
9	100-6708	9	Fork
10	106-4896	4	Fitting-Bulkhead
10:1	100-6710	1	Gasket-Bulkhead
15	106-4943	4	Adapter ASM
15:1	100-6712	1	O-Ring
18	108-3574	11	Nipple-Short
19	94-7100	2	Tee
20	108-3573	9	Elbow-90 DEG
21	94-7103	3	Nipple
22	108-3578	1	Nipple-Short
23	108-3577	1	Union-Short
24	108-3576	1	Elbow-90 DEG, Barbed
25	108-3357	1	Adapter ASM
25:1	100-8637	1	O-Ring
26	108-3358	1	Fitting-Bulkhead
26:1	107-2864	1	Gasket-Bulkhead
27	100-8635	2	Fork

Ref	Part No.	Qty.	Description
28	106-4938	1	Reducer ASM
28:1	100-8637	1	O-Ring
29	100-7051	1	Nut-Bulkhead

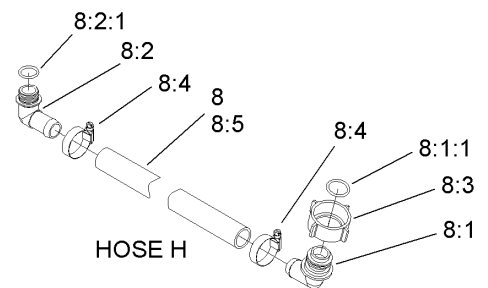
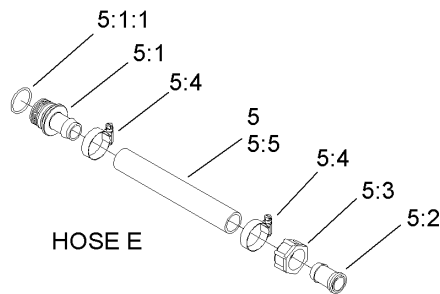
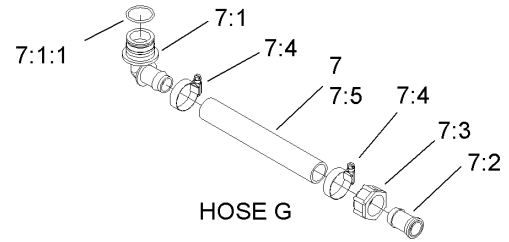
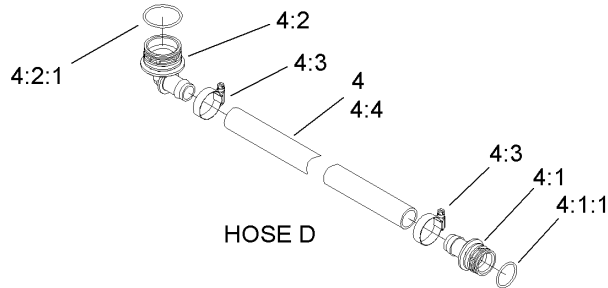
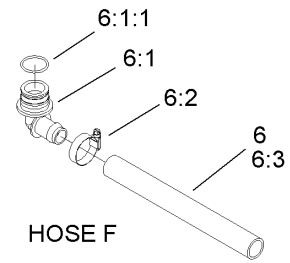
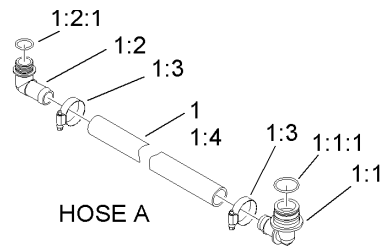

Hose Assemblies No. 1

Ref	Part No.	Qty.	Description
②1		1	Boom Bypass Hose ASM
1:1	106-4945	1	Elbow
1:1:1	100-6712	1	O-Ring
1:2	106-4948	1	Hose Barb ASM
1:2:1	100-6882	1	O-Ring
1:3	2412-3	2	Clamp-Hose
1:4	104-9044	1	Hose-Bypass, Boom
②4		1	Pressure Manifold Hose ASM
4:1	106-4935	1	Hosebarb ASM
4:1:1	100-6712	1	O-Ring
4:2	106-4933	1	Hosebarb ASM
4:2:1	100-8637	1	O-Ring
4:3	2412-3	2	Clamp-Hose
4:4	104-8915	1	Hose-Pressure
②5		1	Main Supply Hose ASM
5:1	106-4935	1	Hosebarb ASM
5:1:1	100-6712	1	O-Ring
5:2	99-0781	1	Hosebarb
5:3	99-0769	1	Nut
5:4	2412-3	2	Clamp-Hose
5:5	104-8909	1	Hose-Bypass
②6		1	Control Supply Hose ASM
6:1	106-4945	1	Elbow
6:1:1	100-6712	1	O-Ring

Ref	Part No.	Qty.	Description
6:2	2412-3	1	Clamp-Hose
6:3	104-8908	1	Hose-Bypass
②7		1	Pressure Control Hose ASM
7:1	106-4945	1	Elbow
7:1:1	100-6712	1	O-Ring
7:2	99-0781	1	Hosebarb
7:3	99-0769	1	Nut
7:4	2412-3	2	Clamp-Hose
7:5	104-8909	1	Hose-Bypass
②8		1	Flowmeter Hose ASM
8:1	106-4949	1	Hosebarb
8:1:1	100-6646	1	O-Ring
8:2	106-4948	1	Hose Barb ASM
8:2:1	100-6882	1	O-Ring
8:3	100-8678	1	Nut
8:4	2412-3	2	Clamp-Hose
8:5	104-8906	1	Hose-Pressure

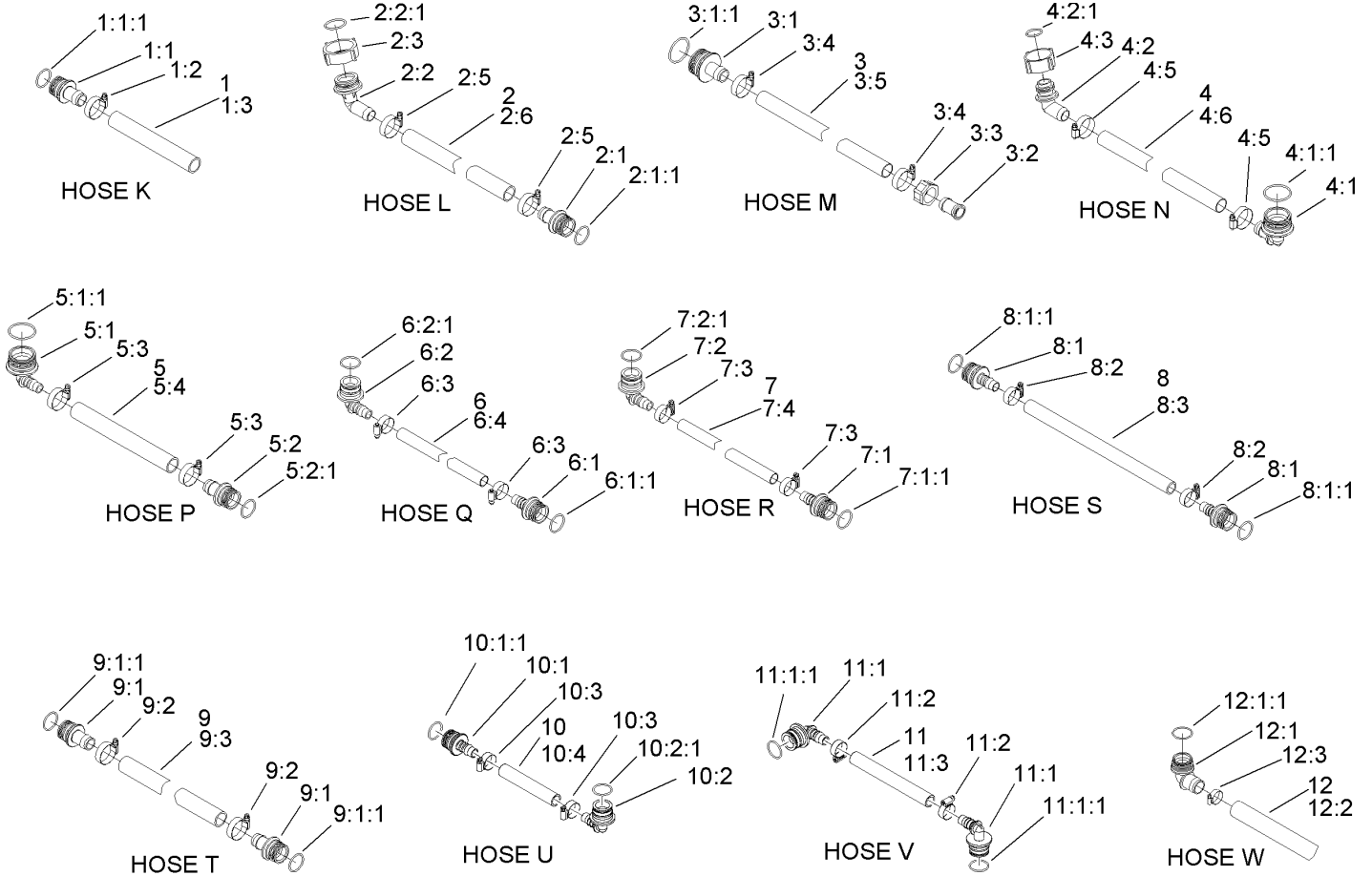

Hose Assemblies No. 2

Ref	Part No.	Qty.	Description
21		1	Main On/Off Bypass Hose ASM
1:1	106-4935	1	Hosebarb ASM
1:1:1	100-6712	1	O-Ring
1:2	2412-3	1	Clamp-Hose
1:3	104-8909	1	Hose-Bypass
22		1	Agitation Valve Hose ASM
2:1	106-4935	1	Hosebarb ASM
2:1:1	100-6712	1	O-Ring
2:2	106-4950	1	Hose Barb ASM
2:2:1	100-8671	1	O-Ring
2:3	100-8669	1	Nut
2:5	2412-3	2	Clamp-Hose
2:6	104-8915	1	Hose-Pressure
23		1	Manifold Tee Hose ASM
3:1	106-4932	1	Hosebarb-Straight
3:1:1	100-8637	1	O-Ring
3:2	99-0781	1	Hosebarb
3:3	99-0769	1	Nut
3:4	2412-3	2	Clamp-Hose
3:5	104-8712	1	Hose
24		1	Relief Valve Hose ASM
4:1	106-4933	1	Hosebarb ASM
4:1:1	100-8637	1	O-Ring
4:2	106-4949	1	Hosebarb

Ref	Part No.	Qty.	Description
4:2:1	100-6646	1	O-Ring
4:3	100-8678	1	Nut
4:5	2412-3	2	Clamp-Hose
4:6	104-8710	1	Hose
25		1	Agitation Valve Hose ASM
5:1	106-4933	1	Hosebarb ASM
5:1:1	100-8637	1	O-Ring
5:2	106-4935	1	Hosebarb ASM
5:2:1	100-6712	1	O-Ring
5:3	2412-3	2	Clamp-Hose
5:4	107-8642	1	Hose
26		1	Rear Hose Agitation ASM
6:1	106-4939	1	Hosebarb-Straight
6:1:1	100-6712	1	O-Ring
6:2	106-4940	1	Hosebarb-90 DEG
6:2:1	100-6712	1	O-Ring
6:3	2412-129	2	Clamp-Hose
6:4	106-1360	1	Hose
27		1	Front Agitation Hose ASM
7:1	106-4939	1	Hosebarb-Straight
7:1:1	100-6712	1	O-Ring
7:2	106-4940	1	Hosebarb-90 DEG
7:2:1	100-6712	1	O-Ring
7:3	2412-129	2	Clamp-Hose

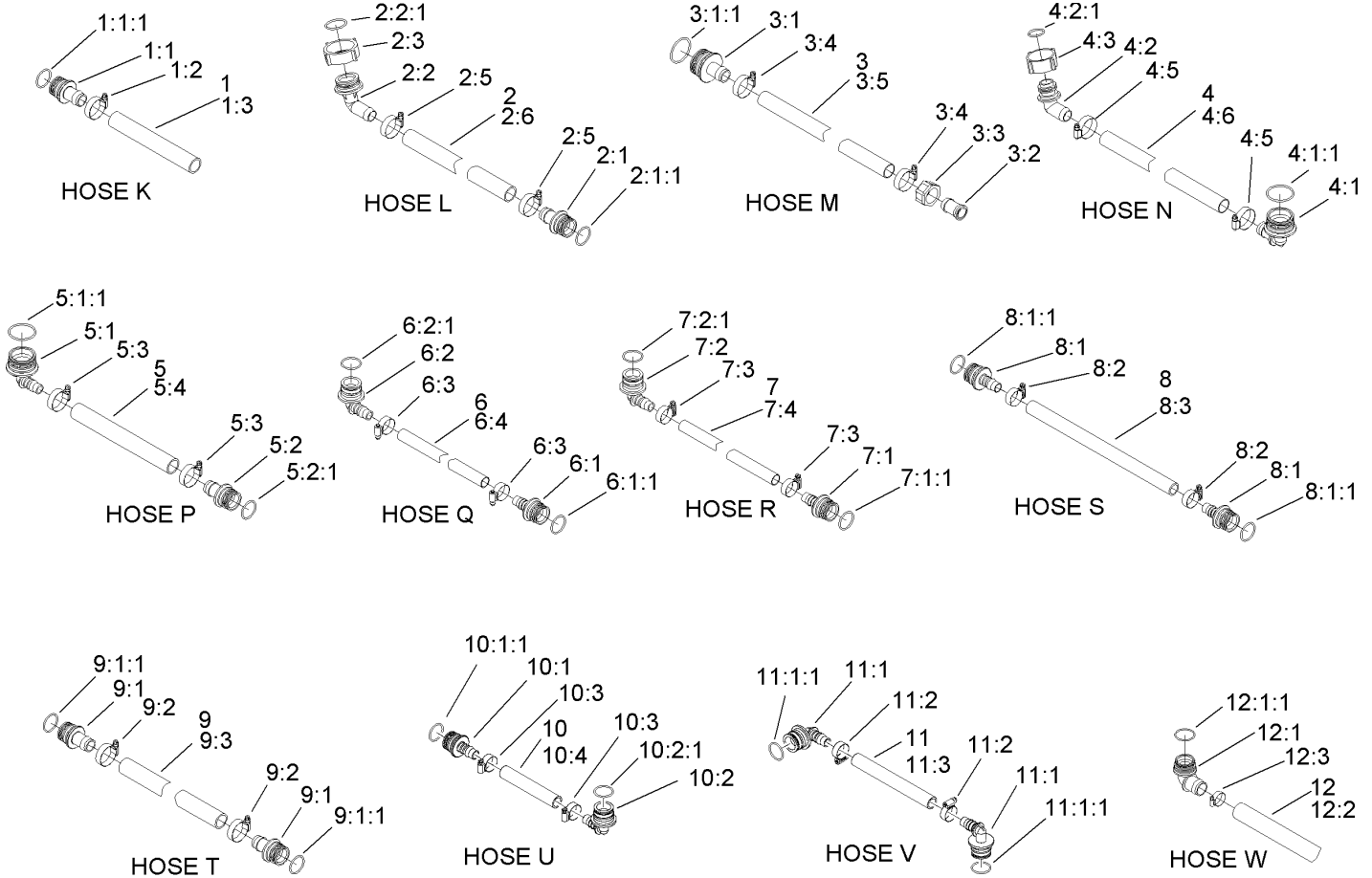

Hose Assemblies No. 2 (continued)

Ref	Part No.	Qty.	Description
7:4	104-8706	1	Hose
28		1	Agitation Hose ASM
8:1	106-4939	2	Hosebarb-Straight
8:1:1	100-6712	1	O-Ring
8:2	2412-129	2	Clamp-Hose
8:3	108-3689	1	Hose
29		1	Agitation Tee Hose ASM
9:1	106-4935	2	Hosebarb ASM
9:1:1	100-6712	1	O-Ring
9:2	2412-3	2	Clamp-Hose
9:3	104-9039	1	Hose-Tee, Agitation
210		1	Agitation Hose ASM
10:1	106-4939	1	Hosebarb-Straight
10:1:1	100-6712	1	O-Ring
10:2	106-4940	1	Hosebarb-90 DEG
10:2:1	100-6712	1	O-Ring
10:3	2412-129	2	Clamp-Hose
10:4	108-3366	1	Hose
211		1	Agitation Hose ASM
11:1	106-4940	2	Hosebarb-90 DEG
11:1:1	100-6712	1	O-Ring
11:2	2412-129	2	Clamp-Hose
11:3	108-3365	1	Hose
212		1	Suction Hose ASM

Ref	Part No.	Qty.	Description
12:1	110-5156	1	Suction Elbow ASM
12:1:1	100-8637	1	O-Ring
12:2	108-3685	1	Hose-Suction
12:3	41327	1	Clamp-Hose

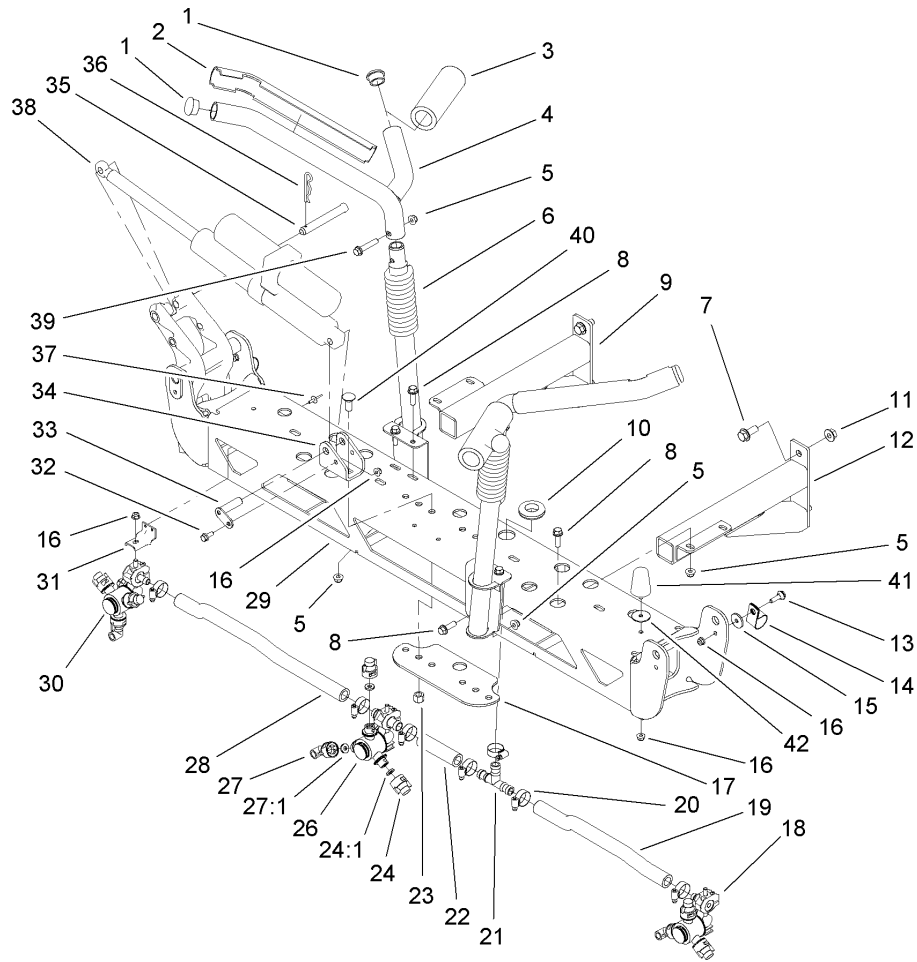

Center Boom Assembly

Ref	Part No.	Qty.	Description
1	108-3489	4	Cap-Tube
2	108-3495	2	Cover-Slide
3	108-3457	2	Spacer
4	108-3476-03	2	Upper Cradle ASM
5	104-8301	12	Nut-Flange, NI
6	108-3472-03	2	Lower Cradle ASM
7	110-5057	4	Capscrew-HHF
8	110-5050	10	Screw-HHF
9	108-3408-03	1	Frame-Mount, Boom (LH)
10	108-3723	1	Grommet
11	108-3745	4	Nut-HF, Whiz
12	108-3409-03	1	Frame-Mount, Boom (RH)
13	108-3744	2	Screw-Shoulder
14	100-1424	2	Clamp-R
15	108-3743	2	Washer
16	104-8300	9	Nut-Flange, NI
17	108-3469-03	1	Plate-Washer
18	108-3726	1	Body-Turret, Single (RH)
19	108-3718	1	Hose-Boom, Center (RH)
20	2412-129	7	Clamp-Hose
21	108-3439	1	Tee
22	108-3717	1	Hose-Boom
23	3296-23	4	Nut-Lock, NI
24	95-9187	6	Cap-Blank

Ref	Part No.	Qty.	Description
24:1	40998	1	Seat-Gasket
26	108-3727	1	Body-Turret, Double
27	95-9186	3	Cap
27:1	40998	1	Seat-Gasket
28	108-3735	1	Hose-Boom, Center (LH)
29	108-3410-03	1	Frame ASM
30	108-3725	1	Body-Turret, Single (LH)
31	107-8775	3	Bracket-Mount, Nozzle
32	110-5053	2	Screw-Flange
33	108-3420	2	Pivot Pin ASM
34	108-3401-03	2	Strap-Clevis
35	108-3436	2	Pin-Clevis
36	3290-468	2	Pin-Cotter
37	3269-18	6	Rivet-Pop
38	108-3438	2	Actuator
39	108-3742	2	Screw-HHF
40	110-5067	4	Screw-CARR
41	110-5070	2	Bumper-Neoprene
42	3256-68	2	Washer-Flat

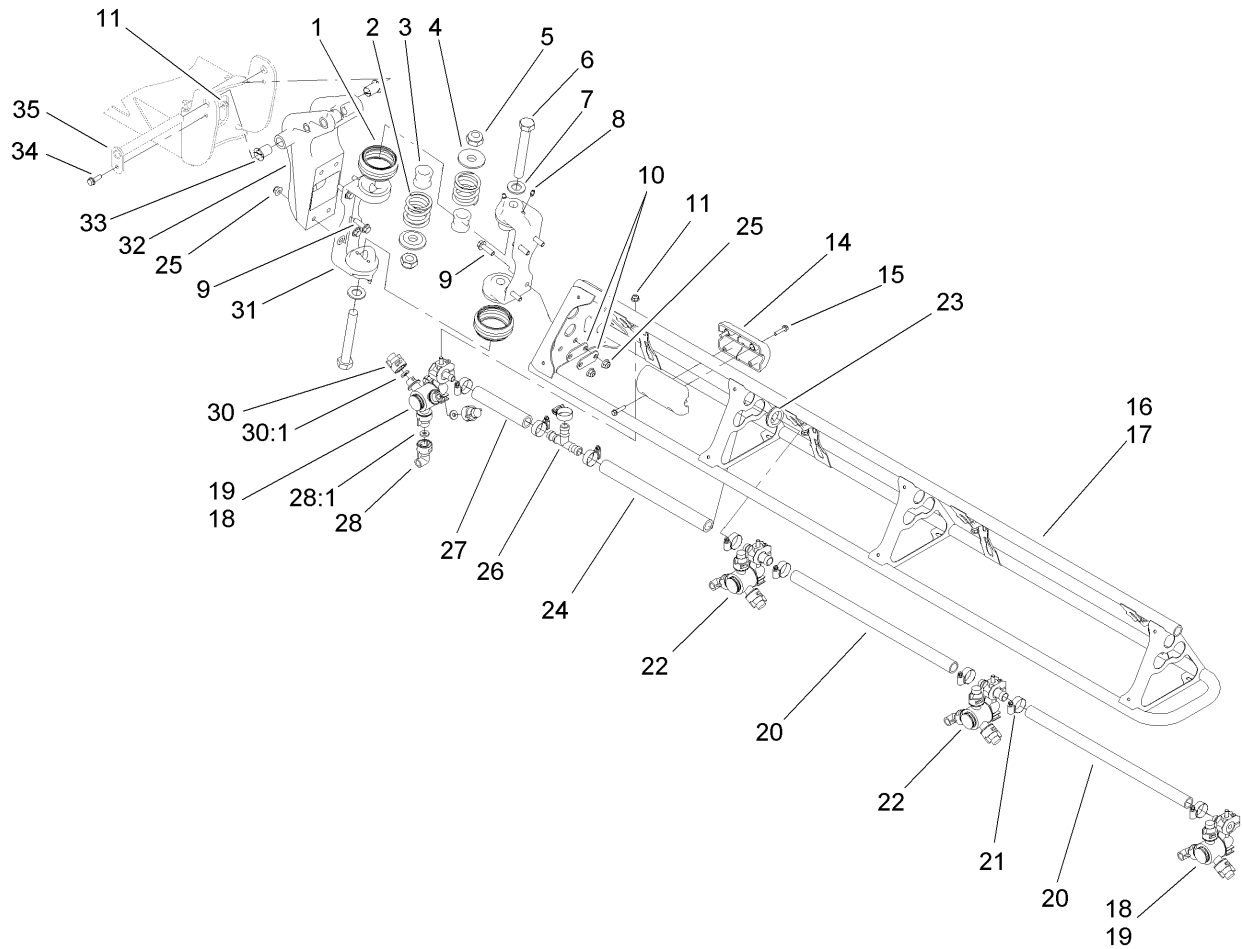

Left and Right Hand Boom Assembly

Ref	Part No.	Qty.	Description
1	108-3459	4	Boot-Hinge
2	108-3440	4	Spring-Breakaway, Boom
3	108-3730	4	Tube-Hinge
4	108-3444	4	Retainer-Spring
5	3296-15	4	Nut-Lock, NI
6	108-3738	4	Screw-HH
7	110-5054	4	Washer-Flat
8	302-5	8	Fitting-Grease
9	110-5050	16	Screw-HHF
10	108-3605	8	Plate-Backing
11	104-8300	10	Nut-Flange, NI
14	108-3429	4	Block-Slide
15	108-3746	8	Screw-Plastite
16	108-3524-03	1	RH Boom ASM
17	108-3525-03	1	LH Boom ASM
18	108-3726	2	Body-Turret, Single (RH)
19	108-3725	2	Body-Turret, Single (LH)
20	40506	4	Hose-Jumper
21	2412-129	18	Clamp-Hose
22	108-3727	4	Body-Turret, Double
23	240-3	4	Grommet-Rubber
24	108-3721	2	Hose-Boom
25	104-8301	16	Nut-Flange, NI
26	108-3439	2	Tee

Ref	Part No.	Qty.	Description
27	108-3728	2	Hose-Boom
28	95-9186	8	Cap
28:1	40998	1	Seat-Gasket
30	95-9187	16	Cap-Blank
30:1	40998	1	Seat-Gasket
31	108-3471-03	4	Hinge
32	108-3600-03	2	Bracket-Pivot
33	100-8541	4	Bushing-A Arm
34	108-3748	2	Screw-HHF
35	108-3419	2	Pivot Pin ASM
36	107-8650	2	Conduit-Convoluted
37	3290-378	4	Tie-Cable

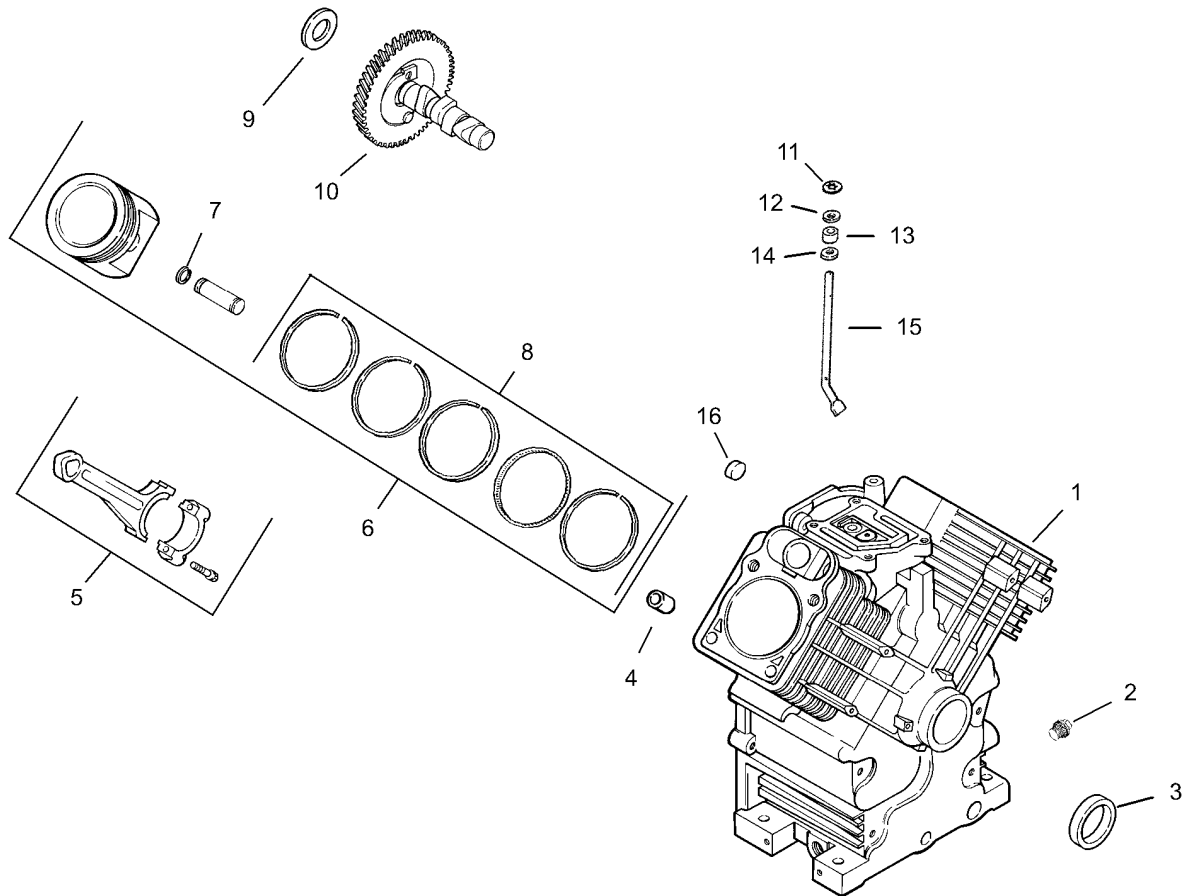

Crankcase Assembly Kohler CH20S-64647

Ref	Part No.	Qty.	Description
1		1	Cylinder Block (Use Miniblock 24 782 15)
2	25 139 57-S	2	Plug-Solid, Square Head (.38)
3	24 032 01-S	1	Seal-Oil
4	24 380 13-S	6	Pin-Locating
5	24 067 13-S	2	Rod-Connecting (Standard)
6	24 067 14-S	2	Rod-Connecting (.25)
6	24 874 17-S	2	Piston W/Ring Set (STD.)(Incl. Ref. #7 And 8)
6	24 874 14-S	2	Piston ASM (.08)
6	24 874 18-S	2	Piston ASM (.25)
6	24 874 19-S	2	Piston ASM (.50)
7	24 018 01-S	4	Retainer-Pin, Piston
8	24 108 11-S	2	Ring Set (STD And .08)
8	24 108 12-S	2	Ring Set (.25)
8	24 108 13-S	2	Set-Ring (.50)
9	12 422 09-S	0	Shim-Camshaft (Red .032)
9	12 422 13-S	0	Shim-Camshaft (Black .04)
9	12 422 07-S	0	Shim-Camshaft (White .028)
9	12 422 08-S	0	Shim-Camshaft (Blue .03)
9	12 422 10-S	0	Shim-Camshaft (Yellow .034)
9	12 422 11-S	0	Shim-Camshaft (Green .036)
9	12 422 12-S	0	Shim-Camshaft (Gray .038)
10	24 012 10-S	1	Camshaft

Ref	Part No.	Qty.	Description
11	24 018 09-S	1	Ring-Retainer
12	M-931010-S	1	Washer-Flat (8 Mm)
13	28 032 09-S	1	Seal-Shaft, Cross Governor
14	24 468 15-S	1	Washer-Flat (.34)
15	24 144 33-S	1	Shaft-Governor Cross
16	52 139 09-S	1	Plug-Cup

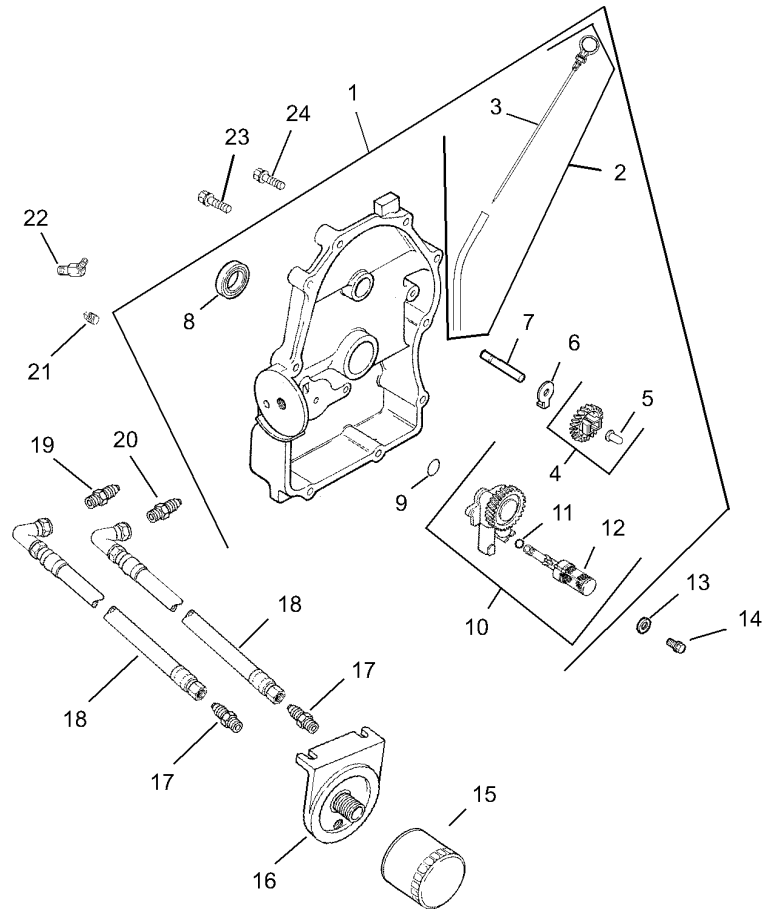

Oil Pan / Lubrication Assembly Kohler CH20S-6467

Ref	Part No.	Qty.	Description
❶1	24 009 96-S	1	Plate, Closure ASM (Incl. Ref. #2-12,19, 20, 22)
❶2	24 755 121-S	3	Kit, Dipstick W/Tube (Incl. Ref. #3)
❶3	24 038 10-S	1	Dipstick
❶4	24 043 12-S	5	Kit, Governor Gear (Incl. Ref. #5)
❶5	12 380 01-S	1	Pin-Regulating, Governor
❶6	52 448 02-S	1	Tab-Locking
❶7	12 144 02-S	1	Shaft-Gear, Governor
❶8	52 032 08-S	1	Seal-Oil
❶9	24 153 08-S	1	O-Ring
❶10	24 393 37-S	1	Oil Pump Assembly (Incl. Ref. #11, 12)
❶11	24 153 01-S	1	O-Ring
❶12	24 381 04-S	1	Pick Up-Oil
❶13	M-631005-S	2	Washer-Plain (6 Mm)
❶14	M-645025-S	2	Screw-HF (M6X1.0X25)
❶15	52 050 02-S	1	Filter-Oil
❶16	25 029 01-S	1	Adapter-Oil Filter, Remote
❶17	52 155 03-S	2	Connector-Hose
❶18	24 326 46-S	2	Hose, Oil
❶19	24 294 08-S	1	Fitting
❶20	24 294 09-S	1	Fitting-Straight
❶21	25 155 11-S	1	Connector 1/4-18 Npt,1/2-20 Sae 45Ø Maleflare
❶22	24 086 16-S	9	Screw-HF (M8X1.25X45)

Ref	Part No.	Qty.	Description
❶23	24 086 17-S	1	Screw-HF (M8X1.25X45)
❶❶	25 454 03-S	2	Tie-Wire

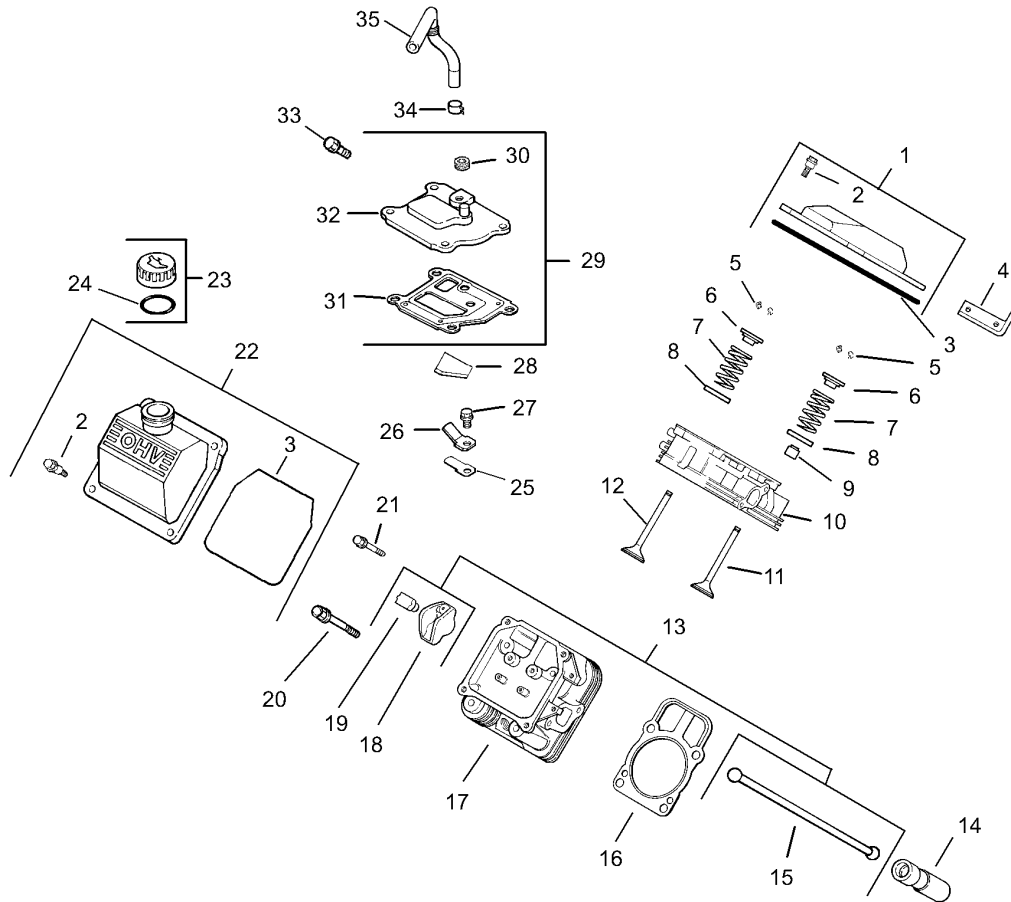

Head / Valve / Breather Assembly Kohler CH20S-64647

Ref	Part No.	Qty.	Description
❶	24 755 74-S	1	Kit, Valve Cover-Plain (Incl. Ref. #2 And 3)
❷	24 086 32-S	4	Screw-Shoulder, M6X1.0X30
❸	24 153 23-S	1	O-Ring
❹	24 445 01-S	1	Strap-Lifting
❺	12 755 03-S	4	Retainer Kit
❻	12 173 01-S	4	Cap-Spring, Valve
❼	24 089 02-S	4	Spring-Valve
❽	235011-S	4	Retainer-Spring
❾	66 032 05-S	2	Seal-Stem, Valve
❿	24 318 68-S	1	No. 1 Cylinder Head ASM
⓫	24 017 01-S	2	Valve-Intake (Standard)
⓬	24 017 02-S	2	Valve-Intake (.25)
⓭	24 016 01-S	2	Valve-Exhaust (Standard)
⓮	24 016 02-S	2	Valve-Exhaust (.25)
⓯	24 755 66-S	1	Kit, Valve Train (Incl. Ref. #15,18,19)
⓰	25 351 01-S	4	Lifter-Valve
⓱	24 411 05-S	4	Rod-Push
⓲	24 041 08-S	2	Gasket-Cylinder Head
⓳	24 318 71-S	1	No. 2 Cylinder Head ASM
⓴	25 186 01-S	4	Arm-Rocker
⓵	24 599 01-S	4	Pivot-Arm, Rocker
⓶	12 086 16-S	8	Screw-Hex Flange (M10X1.5X90)

Ref	Part No.	Qty.	Description
⓷	M-640034-S	4	Screw-HF (M6X1.0X34)
⓸	24 559 03-S	1	Kit, Fuel Pump/Valve Cover (Incl. Ref. # 2 And 3)
⓹	24 755 46-S	1	Kit, Oil Fill Cap (Incl. Ref. #24)
⓺	25 153 02-S	1	O-Ring
⓻	24 402 03-S	1	Reed-Breather
⓼	12 018 01-S	1	Retainer-Reed, Breather
⓽	M-545010-S	1	Screw-HHFTF (M5X0.8X10)
⓾	24 050 01-S	1	Filter-Breather
⓿	24 033 01-S	1	Kit, Breather(Incl. Ref. #30-32)
Ⓚ	25 139 60-S	1	Plug-Hex, Countersunk (.125)
Ⓛ	24 041 23-S	1	Gasket-Breather
Ⓜ	24 096 86-S	1	Cover-Breather
Ⓨ	M-645020-S	4	Screw-Flange, Hex (M6X1.0X20)
Ⓩ	25 237 14-S	1	Clamp-Hose
Ⓚ	24 326 26-S	0	Hose-Breather

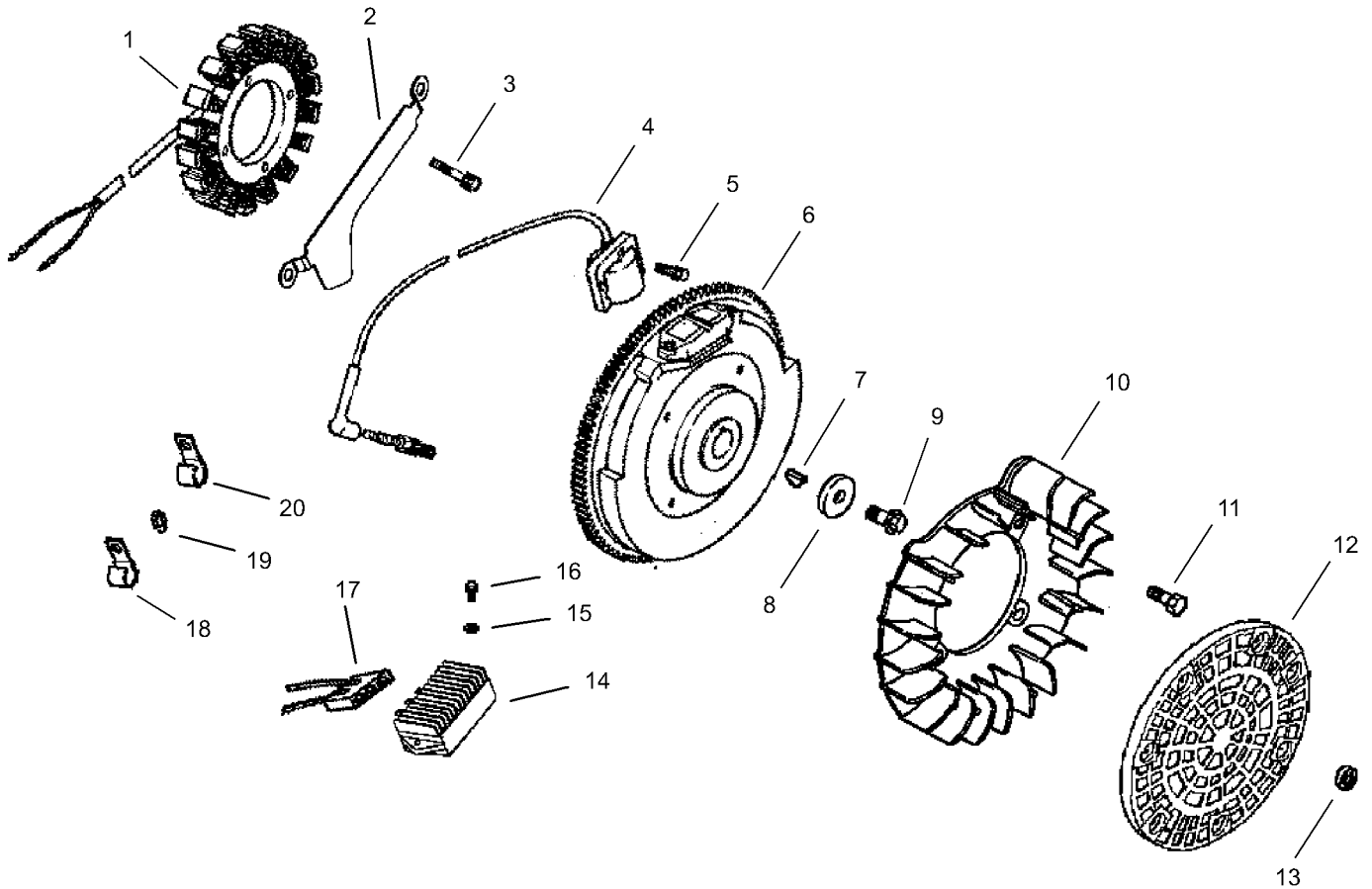

Ignition / Electrical Assembly Kohler CH20S-64647

Ref	Part No.	Qty.	Description
❶	28 085 02-S	1	Kit, Stator W/Connectors (Incl. Ref. #17)
❷	24 126 71-S	1	Bracket-Wire, Stator
❸	M-545030-S	2	Screw-Cap, Hex
❹	24 584 01-S	2	Module-Ignition
❺	M-545020-S	4	Screw-HHFTF (M5X0.8X20)
❻	24 025 01-S	1	Flywheel
❼	X-42-15-S	1	Key (.19 X .62)
❽	12 468 03-S	1	Washer-Flat (.38)
❾	12 086 14-S	1	Screw-Hex, Flange (M10X1.5X45)
❿	24 157 01-S	1	Fan
⓫	25 086 47-S	4	Bolt-Shoulder (M6X1.0X16)
⓬	24 162 03-S	1	Screen-Grass
⓭	24 018 03-S	1	Retainer
⓮	25 403 05-S	1	Rectifier-Regulator (15 Amp)
⓯	X-25-92-S	2	Washer-Flat (.188)
⓰	24 086 18-S	2	Screw-Phi HD (11-16X.88)
⓱	236602-S	1	Connector (3 Contact)
⓲	235173-S	1	Clip-Cable
⓳	X-25-63-S	1	Washer-Flat (.25)
⓴	48 154 02-S	1	Clip-Cable
⓵	12 132 06-S	2	Spark Plug
⓶	24 518 12-S	1	Lead-Black
⓷	24 176 72-S	1	Harness-Wiring

Ref	Part No.	Qty.	Description
⓸	X-22-11-S	1	Washer-Lock, Internal Tooth (1/4)
⓹	25 454 03-S	2	Tie-Wire

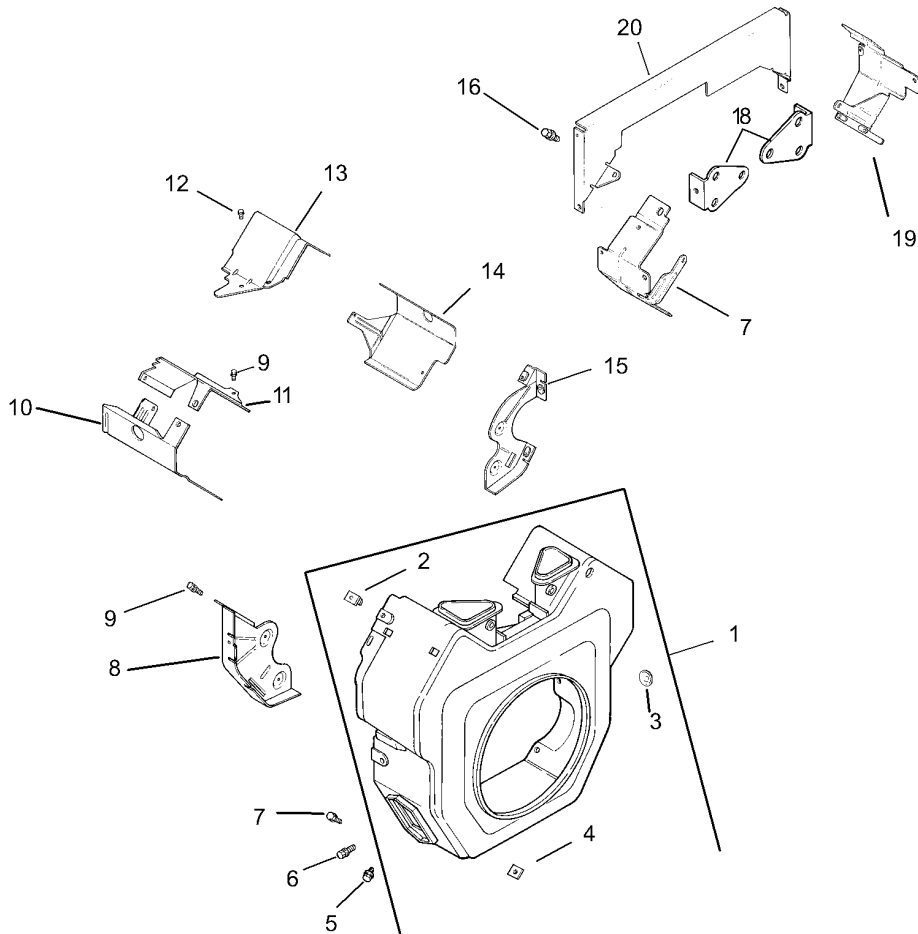

Blower Housing and Baffle Assembly Kohler CH20S-64647

Ref	Part No.	Qty.	Description				
❶	24 027 175-S	1	Housing, Blower (Incl. Ref. #2-4)				
❷	24 100 02-S	2	Nut-Plastic				
❸	25 139 16-S	1	Plug-Button (.56)				
❹	24 100 01-S	3	Nut-Plastic				
❺	M-551016-S	1	Screw-Hex Flange, Heavy (M5X0.8X16)				
❻	M-545016-S	3	Screw-HHFTF (M5X0.8X16)				
❼	M-545020-S	4	Screw-HHFTF (M5X0.8X20)				
❽	24 146 16-S	1	Plate-Backing, No. 2 Side				
❾	M-645016-S	6	Screw-HHFTF (M6X1.0X16)				
❿	24 063 20-S	1	Baffle-Cylinder Barrel, No. 2 Side				
⓫	24 063 17-S	1	Baffle-Valley (No. 2 Side)				
⓬	M-545010-S	2	Screw-HHFTF (M5X0.8X10)				
⓭	24 063 59-S	1	Baffle-Valley (No. 1 Side)				
⓮	24 063 58-S	1	Baffle-Barrel, Cylinder (No. 1 Side)				
⓯	24 146 20-S	1	Plate-Backing (No. 1 Side)				
⓰	M-639010-S	4	Screw-HF				
⓱	24 063 13-S	1	Baffle-Ducted Air, #1 Side				
⓲	24 126 04-S	2	Bracket-Support				
⓳	24 063 12-S	1	Baffle-Ducted Air, #1 Side				
⓴	24 113 12-S	1	Decal				

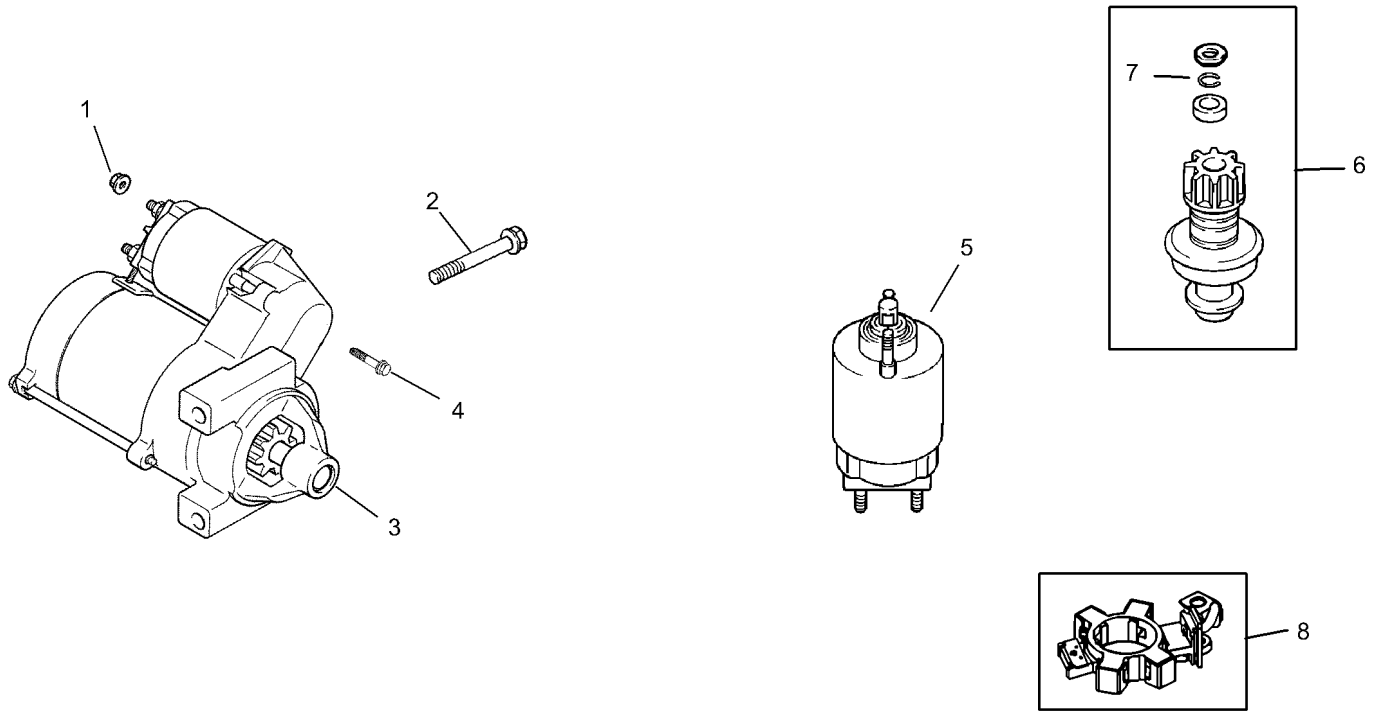

Starting System Kohler CH20S-64647

Ref	Part No.	Qty.	Description
❶	M-841080-S	1	Nut-Hex, Flange (M8X1.25)
❷	M-839080-S	2	Screw-Hex, Flange (M8X1.25X70)
❸	24 098 09-S	1	Starter, Solenoid Shift ASM (Incl. Ref. #4-18)
❹	25 086 113-S	3	Screw-Torx Head, External
❺	25 435 05-S	4	Kit, Solenoid (Incl. Ref. #4)
❻	25 755 33-S	7	Kit, Pinion Drive (Incl. Ref. #7)
❼	25 141 05-S	1	Ring-Retaining
❽	25 221 01-S	1	Brush Kit

--	--	--	--

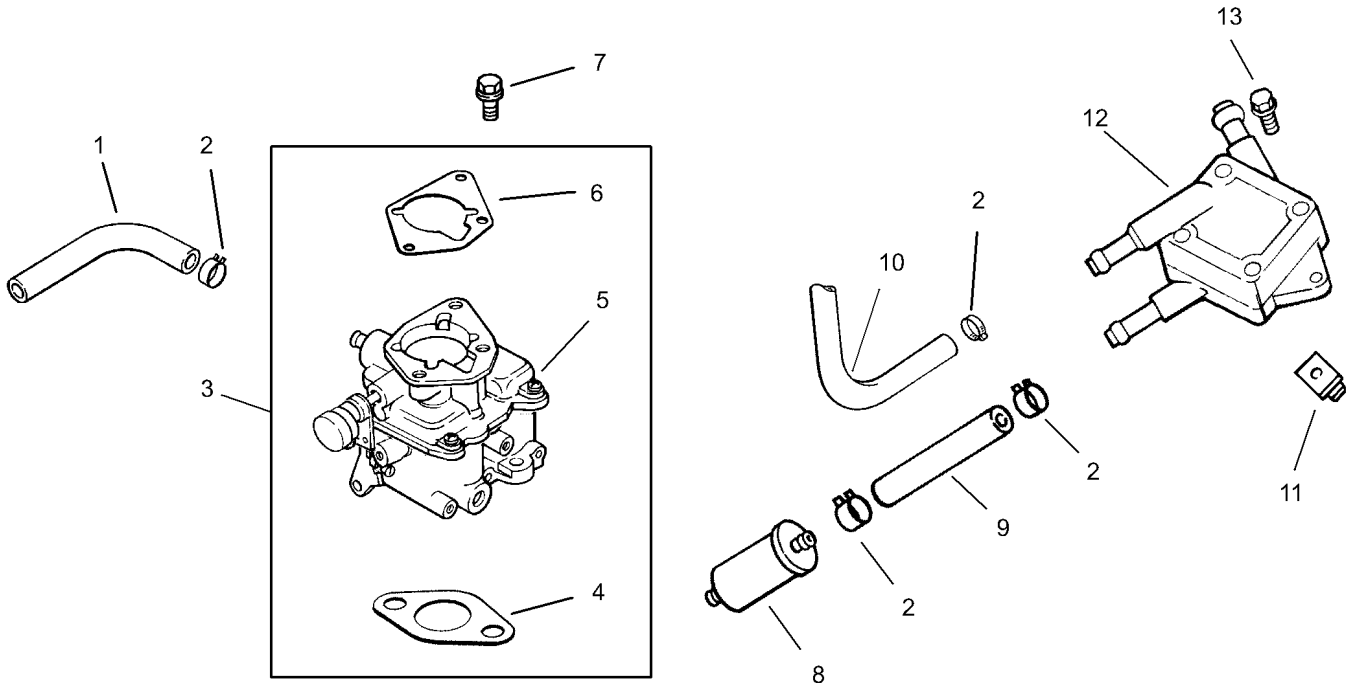

Fuel System Assembly Kohler CH20S-64647

Ref	Part No.	Qty.	Description
❶	25 353 32-S	1	Line-Fuel
❷	25 237 14-S	6	Clamp-Hose
❸	24 853 33-S	1	Kit, Carburetor W/Gasket (Incl. Ref. #4-6)
❹	24 041 06-S	1	Gasket-Base, Air Cleaner
❺		1	Carburetor Assembly (Incl. Ref. #24 75701-S, 24 757 02-S, 24 757 03-S, 24 757 07-S, 24 757 08-S & 24 757 09-S)2405333 (For Information Only Not Available Separately)
❻	24 041 17-S	1	Gasket-Carburetor
❼	M-651030-S	2	Screw-Hex Flange (M6X1.0X30)
❽	24 050 02-S	1	Filter-Fuel
❾	25 353 15-S	1	Line-Fuel, 3-1/2"
❿	24 353 02-S	1	Line-Fuel (15.5)
⓫	24 100 01-S	2	Nut-Plastic
⓬	24 393 16-S	1	Pump-Pulse, Fuel
⓭	24 086 12-S	2	Screw-Hex Cap (M6X1.7X18)
Ⓧ	24 755 125-S	1	High Altitude Kit
Ⓨ	24 757 01-S	1	Solenoid Repair Kit
Ⓩ	24 757 02-S	1	Float Repair Kit
Ⓩ	24 757 03-S	1	Carburetor Repair Kit
Ⓩ	24 757 07-S	1	Choke Repair Kit
Ⓩ	24 757 08-S	1	Acc Pump Repair Kit

Ref	Part No.	Qty.	Description
Ⓩ	24 757 09-S	1	Acc Pump Seal Repair Kit

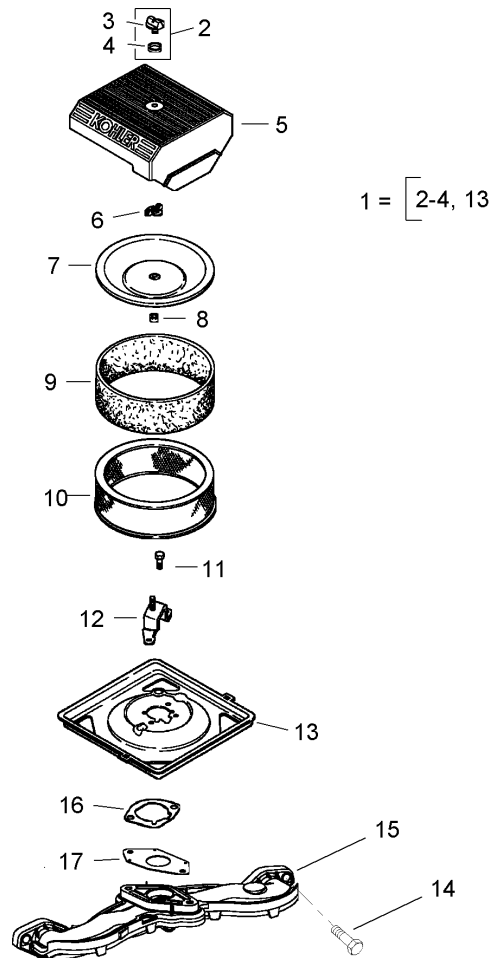

Air Intake / Filtration Assembly Kohler CH20S-64647

Ref	Part No.	Qty.	Description
1	24 743 05-S	1	Kit, Air Cleaner Cover (Incl. Ref. #2-5, 12)
2	54 755 01-S	1	Kit, Knob With Seal (Incl. Ref. #3, 4)
3	25 341 03-S	1	Knob-Cover
4	24 153 20-S	1	Seal
5	24 096 67-S	1	Cover-Cleaner, Air
6	12 100 01-S	1	Nut-Wing
7	24 096 01-S	1	Cover-Air Cleaner, Inner
8	24 032 03-S	1	Seal-Inner Air Cleaner
9	24 083 02-S	1	Element, Precleaner
10	47 083 03-S	1	Element, Air Cleaner
11	M-639016-S	3	Screw-HF (M6X1.0X16)
12	24 126 21-S	1	Bracket-Base, Air Cleaner
13	24 094 24-S	1	Base, Air Cleaner
14	25 086 84-S	4	Screw-HF (M6X1.0X55)
15	24 164 14-S	1	Manifold-Intake
16	24 041 01-S	2	Gasket-Manifold, Intake
17	24 041 06-S	1	Gasket-Base, Air Cleaner

--	--	--	--

NOTES

NOTES

