



Commercial Walk-Behind Mower 15HP T-Bar Hydro Drive with 91cm TURBO FORCE® Cutting Unit

Model No. 30032 - 280000001 and up.

Parts Catalog

Ordering Replacement Parts

To order replacement parts, please supply the part number, the quantity, and the description of each part desired.

Understanding Reference Numbers

Each Identified part in an illustration has a reference number. The reference number for a part also appears in the parts list, along with other information about the part.

This catalog uses two special reference number formats, one to indicate parts in a service assembly and another to indicate the quantity of a given part in an illustration.

Service Assembly Reference Numbers

Parts in service assemblies have reference numbers in the form a:b. The a represents the reference number of the entire service assembly and the b represents a sequential number unique to each part within the service assembly.

For example, a wheel assembly might be identified by reference number 6, the tire by 6:1, the valve by 6:2, and the wheel by 6:3. When you order the assembly identified by reference number 6, you receive all parts identified by reference numbers 6:1, 6:2, and 6:3. However, you may also order any part individually. Reference numbers of this type appear in illustrations and in part lists.

Reference Numbers Indicating Quantity

In an illustration, if a reference number indicates more than one part, the reference number has the form nX y. The n represents the quantity of the part, the X is the multiplication symbol, and the y represents the reference number.

For example, in an illustration, the reference number 2X 37 means that two of the parts identified by reference number 37 are indicated.

Contents

Description	Page	Description	Page
Engine and Clutch Assembly	3	Cylinder and Crankcase Assembly Kawasaki FH430V-AS53	22
Fuel System, Hydraulic Pump and Filter Assembly	4	Piston and Crankshaft Assembly Kawasaki FH430V-AS53	23
Hydraulic Pump Assembly No. 114-3400 and 114-3401	5	Valve and Camshaft Assembly Kawasaki FH430V-AS53	24
Pump Drive and Wheel Assembly	6	Lubrication Equipment Assembly Kawasaki FH430V-AS53	25
Hydraulic Wheel Motor Assembly No. 104-1171	7	Cooling Equipment Assembly Kawasaki FH430V-AS53	26
Lower Control Assembly	8	Electric Equipment Assembly Kawasaki FH430V-AS53	27
Hydraulic Hose Assembly	9	Control Equipment Assembly Kawasaki FH430V-AS53	28
Upper Control Assembly	10	Carburetor Assembly Kawasaki FH430V-AS53	29
Control Panel Assembly	11	Air Filter and Muffler Assembly Kawasaki FH430V-AS53	30
Parking Brake Assembly	12	Fuel Tank and Valve Assembly Kawasaki FH430V-AS53	31
Power-Take-Off Idler and Weight Assembly	13	Starter Assembly Kawasaki FH430V-AS53	32
Carrier Frame Assembly	14	Label Assembly Kawasaki FH430V-AS53	33
Deck Drive and Baffle Assembly	15	Attachments and Accessories List	34
Deck Assembly No. 112-7085	16		
Lever Assembly No. 107-1664	17		
Spindle Assembly No. 110-6950	18		
Spindle Assembly No. 110-0728	19		
Deck Deflector, Roller and Cover Assembly	20		
Deflector Assembly No. 110-0790	21		

Part Description Abbreviations

Part descriptions in this catalog may include the following abbreviations.

AR. as required	HYD. hydraulic
ASM. assembly	LH. left hand
BBC. blade brake clutch	NI. nylon insert
CARR. carriage	NPTF. national pipe thread fine
DEG. degrees	PFH. phillips flat head
EXT. external	PPH. phillips pan head
FH. flat head	PPHTF. phillips pan head thread forming
GA. gauge	PRH. phillips round head
HD. heavy-duty	PTH. phillips truss head
HF. hex flange	PTO. power-take-off
HH. hex head	RH. right hand
HHF. hex head flange	ROPS. roll-over protection system
HHFTF. hex head flange thread forming	SFH. slotted fillister head
HJ. hex jam	SHH. slotted hex head
HLH. hex lag head	SHWH. slotted hex washer head
HOC. height-of-cut	SPH. slotted pan head
HSBH. hex socket button head	SQH. square head
HSFH. hex socket flat head	SRH. slotted round head
HSH. hex socket head	STD. standard
HWH. hex washer head	TAP. self tapping
HWHTF. hex washer head thread forming	TTH. torx truss head

Footnotes

- ❶ Not illustrated
- ❷ Obtain from your local Kawasaki dealer

- ❸ Not serviced separately

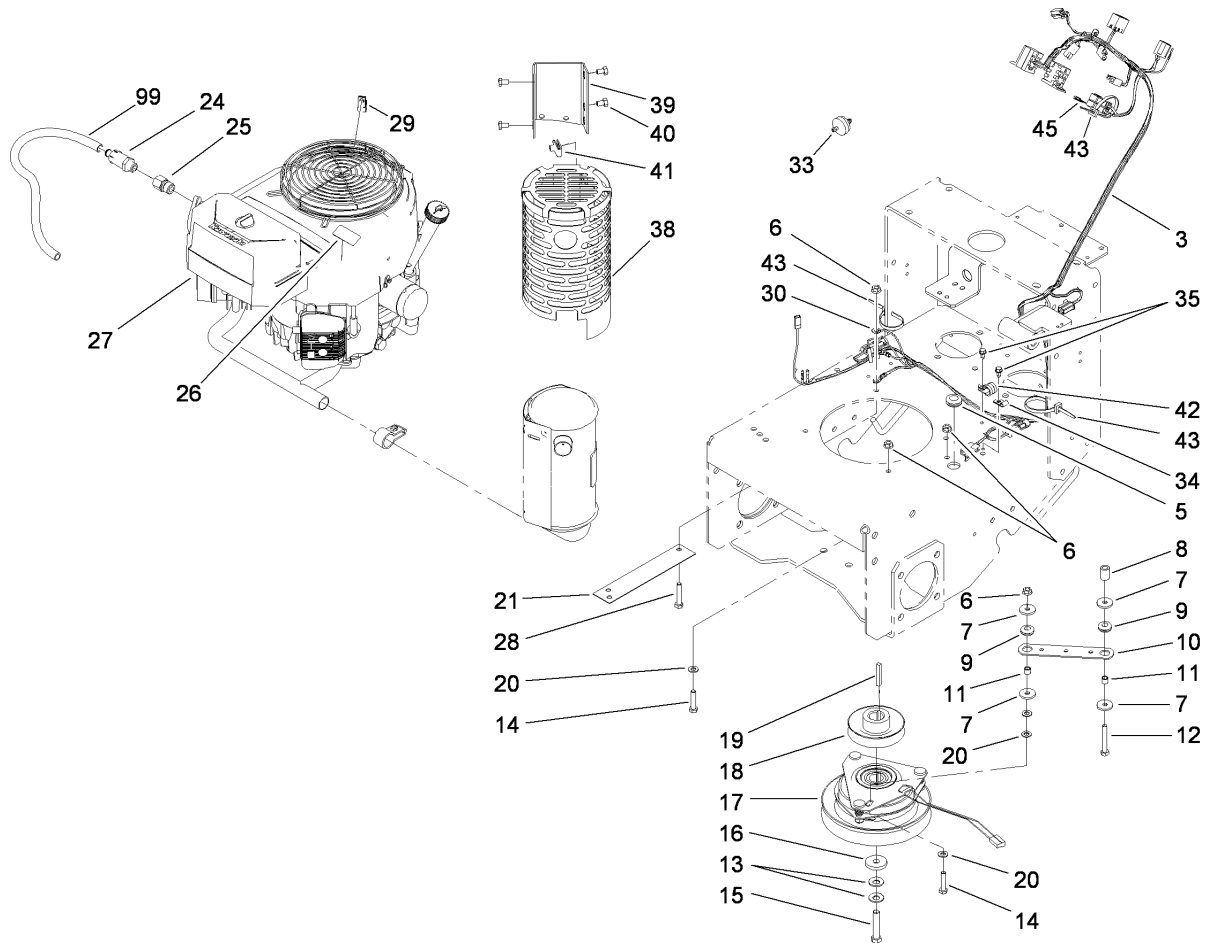

Engine and Clutch Assembly

Ref	Part No.	Qty.	Description
3	114-3420	1	Harness-Wire
5	112-7069	1	Grommet
6	32128-20	6	Nut-HF
7	1-613235	4	Washer
8	104-6373	1	Tube-Retainer
9	1-633630	2	Grommet-Brake
10	1-633543-03	1	Strap-Clutch, Brake
11	1-633545	2	Spacer
12	322-11	1	Screw-HH
13	1-603610	2	Washer-Spring
14	322-7	4	Screw-HH
15	3212-9	1	Screw-HH
16	107-4136	1	Washer
17	105-2635	1	Clutch / Brake
18	44-5940	1	Pulley
19	608006	1	Key-Square
20	3256-23	5	Washer-Flat
21	94-5847-01	1	Cover-Pulley
24	92-6877	1	Valve-Drain, Oil
25	103-1966	1	Adapter
26	106-5517	1	Decal-Surface, Hot
 27		1	Engine-Kawasaki, FH430V-As53
28	322-9	1	Screw-HH
29	2412-87	1	Clamp-Cable

Ref	Part No.	Qty.	Description
30	3255-8	1	Washer-Lock
33	56-6360	1	Filter-Fuel
34	2412-72	1	Clip-Closed, Insulated
35	12-3270	2	Screw
38	106-8785-03	1	Muffler Guard ASM
39	114-3451-03	1	Bracket-Guard, Muffler
40	322-3	5	Screw-HH
41	94-2413	5	U-Nut
42	2412-134	1	R-Clamp
43	3290-378	5	Tie-Cable
45	218-578	1	Fuse-10 Amp
99	103-1964	1	Hose-Drain, Oil

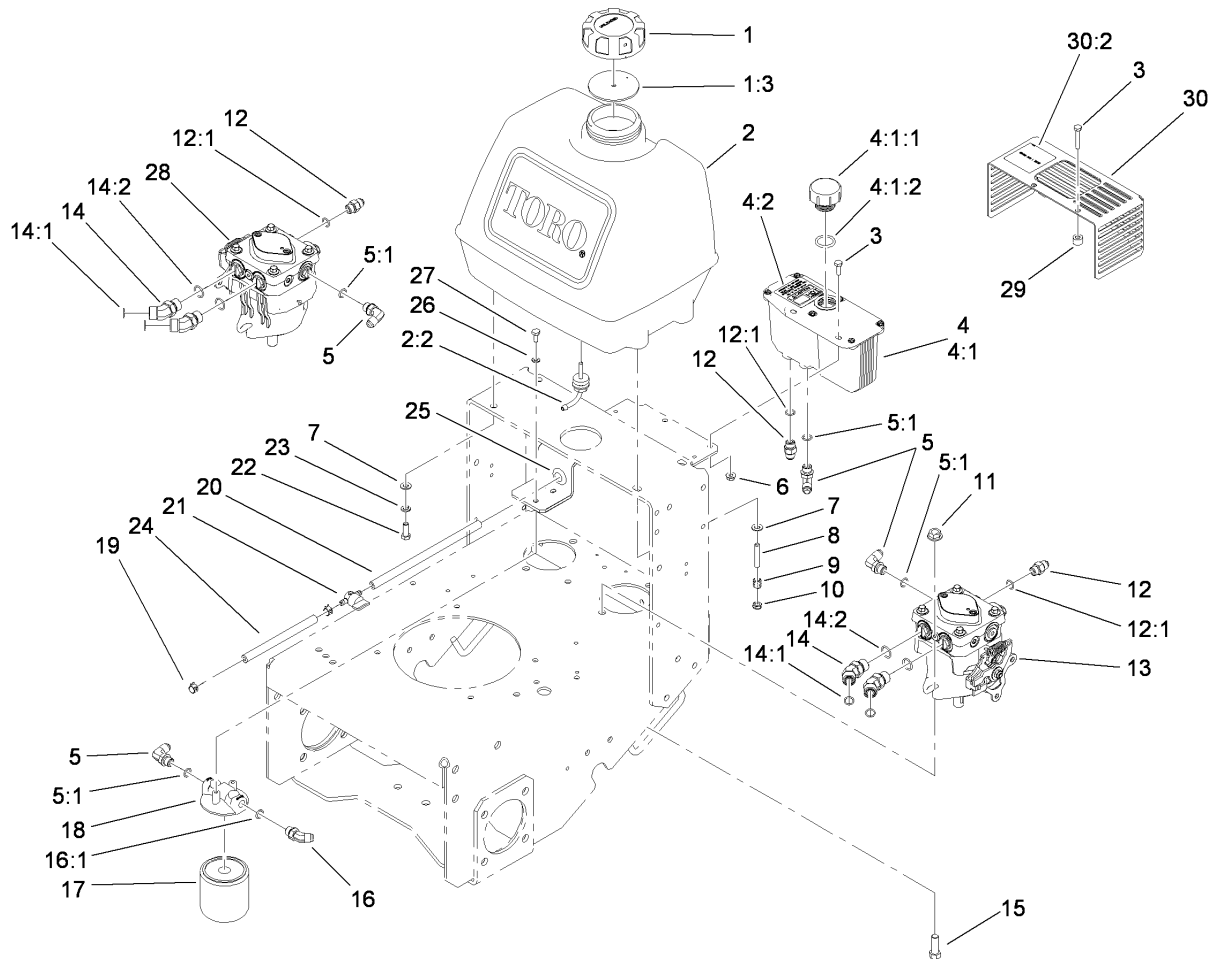

Fuel System, Hydraulic Pump and Filter Assembly

Ref	Part No.	Qty.	Description
1	88-3980	1	Gas Cap ASM
1:3	88-4010	1	Gasket-Cap, Gas
2	106-0730	1	Fuel Tank ASM
2:2	103-2605	1	Fitting-Fuel, Bulkhead
3	321-9	2	Screw-HH
4	103-1947	1	HYD Reservoir ASM
4:1		1	Reservoir-HYD
4:1:1	103-1948	1	Cap-Reservoir, HYD
4:1:2	103-1949	1	Gasket-Cap
4:2	1-523552	1	Decal-Tank, HYD
5	353-374	4	Elbow-90 DEG
5:1	237-42	1	O-Ring
6	32128-33	2	Nut-HF
7	3256-23	4	Washer-Flat
8	104-8121	2	Stud-Threaded
9	1-633349	2	Spring-Tank, Fuel
10	3296-47	2	Nut-Lock, NI
11	32128-42	4	Nut-HF
12	353-384	3	Fitting-Straight
12:1	237-42	1	O-Ring
13	114-3400	1	Pump-HYD, Left
14	340-101	4	Fitting-HYD, 45 DEG
14:1	237-30	1	O-Ring
14:2	237-79	1	O-Ring

Ref	Part No.	Qty.	Description
15	324-5	4	Screw-HH
16	353-212	1	Fitting-HYD, 45 DEG
16:1	237-42	1	O-Ring
17	1-633752	1	Filter-HYD, Winter
17	1-633750	1	Filter-Oil, HYD
18	104-7836	1	Head-Filter
19	2412-98	4	Clamp
20	110-4894	1	Hose-Fuel
21	1-603770	1	Valve-Fuel
22	322-4	2	Screw-HH
23	3253-4	2	Washer-Lock
24	107-0588	1	Hose-Fuel
25	112-7069	1	Grommet
26	3253-3	2	Washer-Lock
27	321-3	2	Screw-HH
28	114-3401	1	Pump-HYD, Right
29	105-3619	2	Spacer
30	112-7060	1	Shield ASM
30:2	107-2131	1	Decal-Surface, Hot

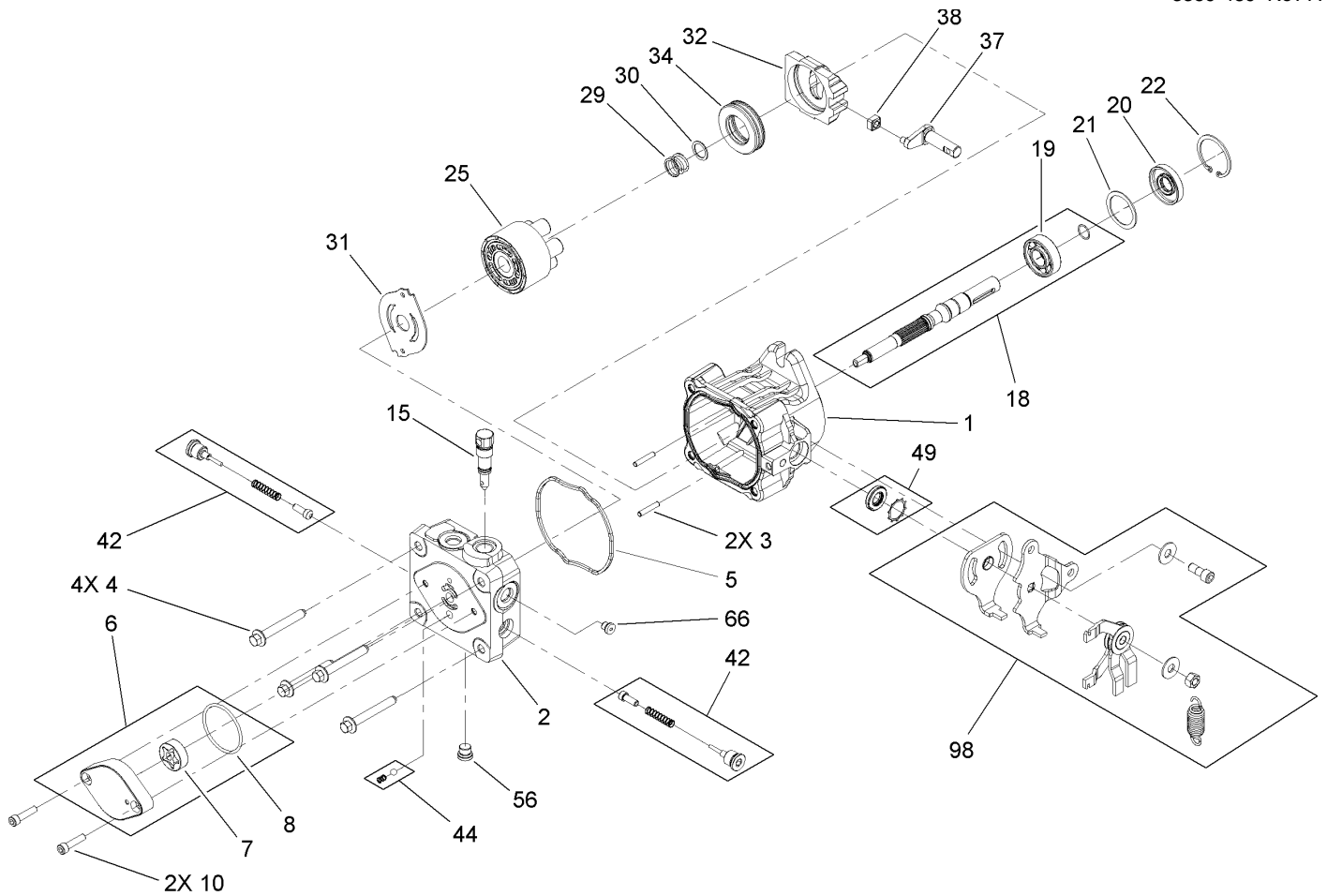

Hydraulic Pump Assembly No. 114-3400 and 114-3401

Ref	Part No.	Qty.	Description
1	114-0278	1	Housing Kit
2	106-8752	1	End Cap Kit (W/Poppets)
3	106-8753	2	Pin-Headless, Straight
4	106-8754	4	Bolt-HF
5	106-8755	1	O-Ring
6	106-8756	1	Charge Pump Kit
7	104-2122	1	Gerotor ASM
8	106-8757	1	O-Ring
10	104-2111	2	Capscrew
15	106-8759	1	Bypass Valve Kit
18	103-2664	1	Input Shaft Kit
19	104-5311	1	Bearing-Ball
20	104-5310	1	Seal-Lip
21	104-5308	1	Spacer
22	104-5309	1	Ring-Retaining
25	103-2666	1	Cylinder Block Kit
29	94-1936	1	Spring-Block
30	94-1937	1	Washer-Block, Thrust
31	105-6185	1	Plate-Valve
32	94-1907	1	Swashplate-Variable
34	94-6922	1	Bearing-Thrust
37	104-2112	1	Trunnion ASM
38	94-1910	1	Guide-Slot
42	98-3252	2	Valve-Check (W/Poppet)

Ref	Part No.	Qty.	Description
44	106-8760	1	Charge Relief Valve Kit
49	106-8761	1	Trunnion Seal / Retainer Kit
56	106-8762	1	Plug-HSH
66	106-8763	1	Plug-HSH
98	114-0277	1	Return Kit
99	105-6184	1	Seal Kit

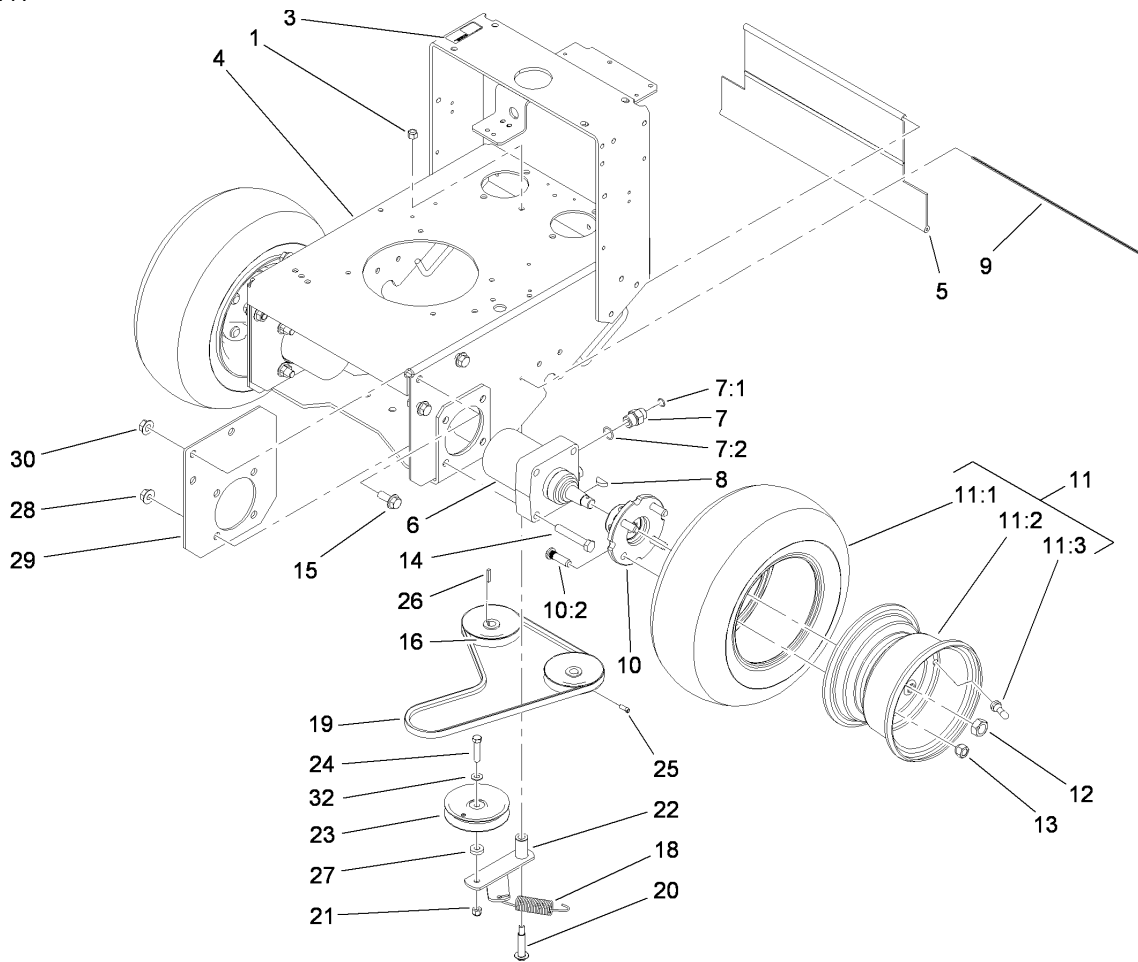

Pump Drive and Wheel Assembly

Ref	Part No.	Qty.	Description
1	3296-6	1	Nut-Lock
3	93-9353	1	Decal-Shut Off, Fuel
4	114-0243-01	1	Frame ASM
5	95-1526	1	Shield-Trailing
6	104-1171	2	Motor-Wheel
7	340-6	4	Fitting-HYD, Straight
7:1	237-30	1	O-Ring
7:2	237-80	1	O-Ring
8	3257-8	2	Key-Woodruff
9	95-1529	1	Rod-Shield
10	105-0800	2	Wheel Hub / Stud ASM
10:2	10-6830	4	Stud-Type, Drive
11	106-0892	2	Wheel And Tire ASM
11:1	104-6322	1	Tire
11:2	106-0893	1	Wheel
11:3	232-27	1	Stem-Valve
12	85-7310	2	Nut-Motor, Wheel
13	242-50	8	Nut-Lug
14	325-12	8	Screw-HH
15	3234-32	6	Screw-HHF
16	105-5648	2	Pulley-Pump
18	68-9950	1	Spring-Traction
19	110-5049	1	Belt-V
20	27-6230	1	Bolt-Wheel

Ref	Part No.	Qty.	Description
21	3296-39	1	Nut-Lock, NI
22	86-4770	1	Idler Lever ASM
23	93-1622	1	Pulley-Idler
24	323-9	1	Screw-HH
25	3241-5	4	Screw-Set
26	1-807272	2	Key
27	9202204	1	Washer
28	32128-49	8	Nut-HHF
29	108-6657-01	2	Plate-Frame
30	32128-23	6	Nut-HF
32	3256-24	1	Washer-Flat

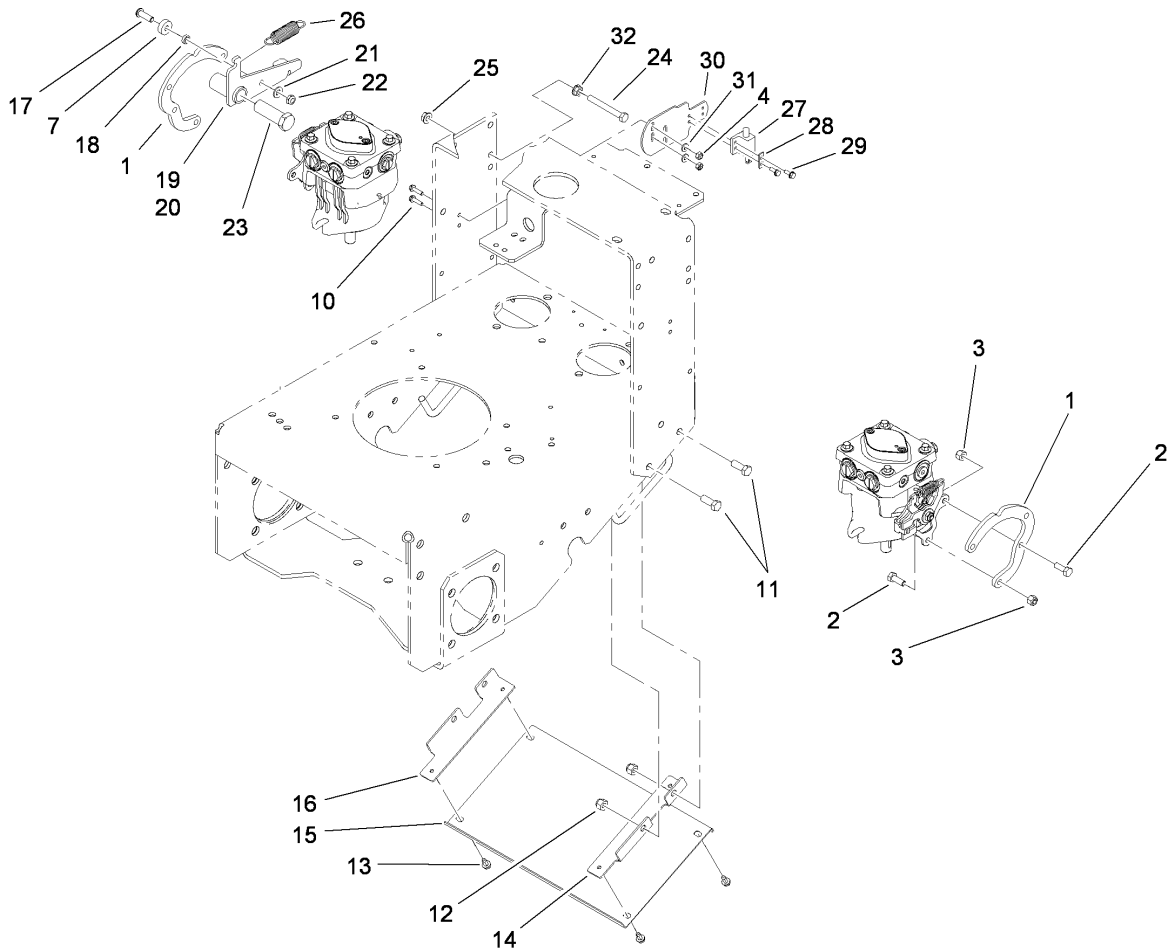

Lower Control Assembly

Ref	Part No.	Qty.	Description
1	112-9722	2	Bracket-Adapter, Pump
2	322-4	4	Screw-HH
3	3296-29	4	Nut-Lock, NI
4	3296-2	4	Nut-Lock
7	251-259	2	Bearing-Ball
10	32105-13	4	Screw-HWH
11	323-6	4	Screw-HH
12	3296-39	4	Nut-Lock, NI
13	12-3270	4	Screw
14	110-5012-01	1	Angle-Mounting, Left
15	110-5014-01	1	Panel-Bottom
16	110-5013-01	1	Angle-Mounting, Right
17	3274-104	2	Screw-HSBH
18	82-4240	2	Spacer-Bearing
19	112-9726	1	RH Detent Arm ASM
20	112-9725	1	LH Detent Arm ASM
21	3256-23	2	Washer-Flat
22	3296-47	2	Nut-Lock, NI
23	112-9724	2	Pin-Adjustment, Neutral
24	322-13	2	Screw-HH
25	32128-25	2	Nut-HF
26	105-1210	2	Spring-Extension
27	1-513152	2	Switch-Closed, Normally
28	82-4570	2	Plate-Switch

Ref	Part No.	Qty.	Description
29	32144-1	4	Screw-Taptite
30	112-9723-01	2	Bracket-Neutral
31	3256-14	4	Washer-Flat
32	109-5715	2	Nut-HHF, Smooth

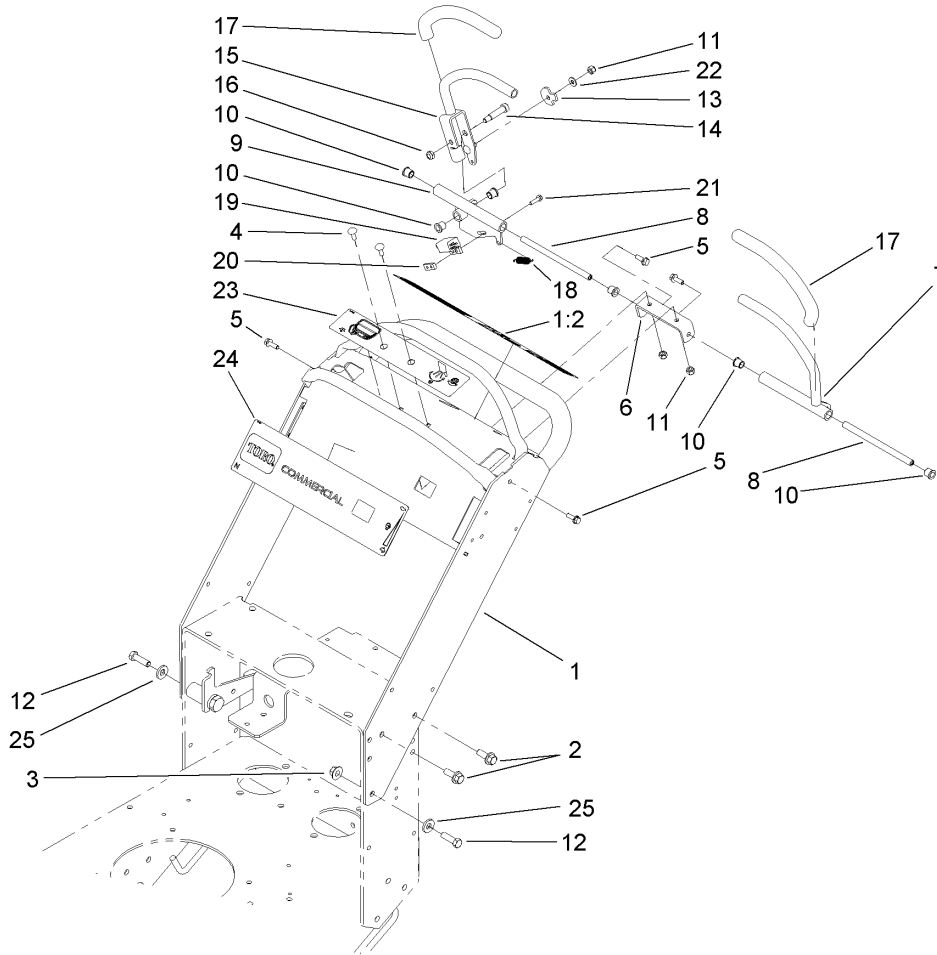

Upper Control Assembly

Ref	Part No.	Qty.	Description
1	114-3437	1	Handle ASM
1:2	114-3422	1	Decal-Warning, Control
2	3234-42	4	Screw-HHF
3	32128-43	4	Nut-Flange
4	3229-1	2	Screw-CARR
5	3234-4	4	Screw-HHF
6	114-0235	1	Bracket-Support
7	114-0272	1	Control Lever ASM
8	114-0260	2	Shaft-Pivot
9	114-0234	1	Motion Control ASM
10	103-9928	6	Bearing
11	3296-42	3	Nut-Lock, NI
12	323-7	2	Screw-HH
13	114-0268	1	Cam-Lever, Handle Stop
14	114-0239	1	Screw-HSH
15	114-0238	1	Lever ASM
16	3296-47	1	Nut-Lock, NI
17	114-0241	2	Grip-Lever
18	114-0249	1	Spring-Extension
19	1-513152	1	Switch-Closed, Normally
20	1-633181	1	Plate-Tapped
21	32105-13	2	Screw-HWH
22	3256-22	1	Washer-Flat
23	114-3424	1	Decal-Control

Ref	Part No.	Qty.	Description
24	114-3442	1	Decal-Panel, Control
25	98-5975	2	Washer-Belleville

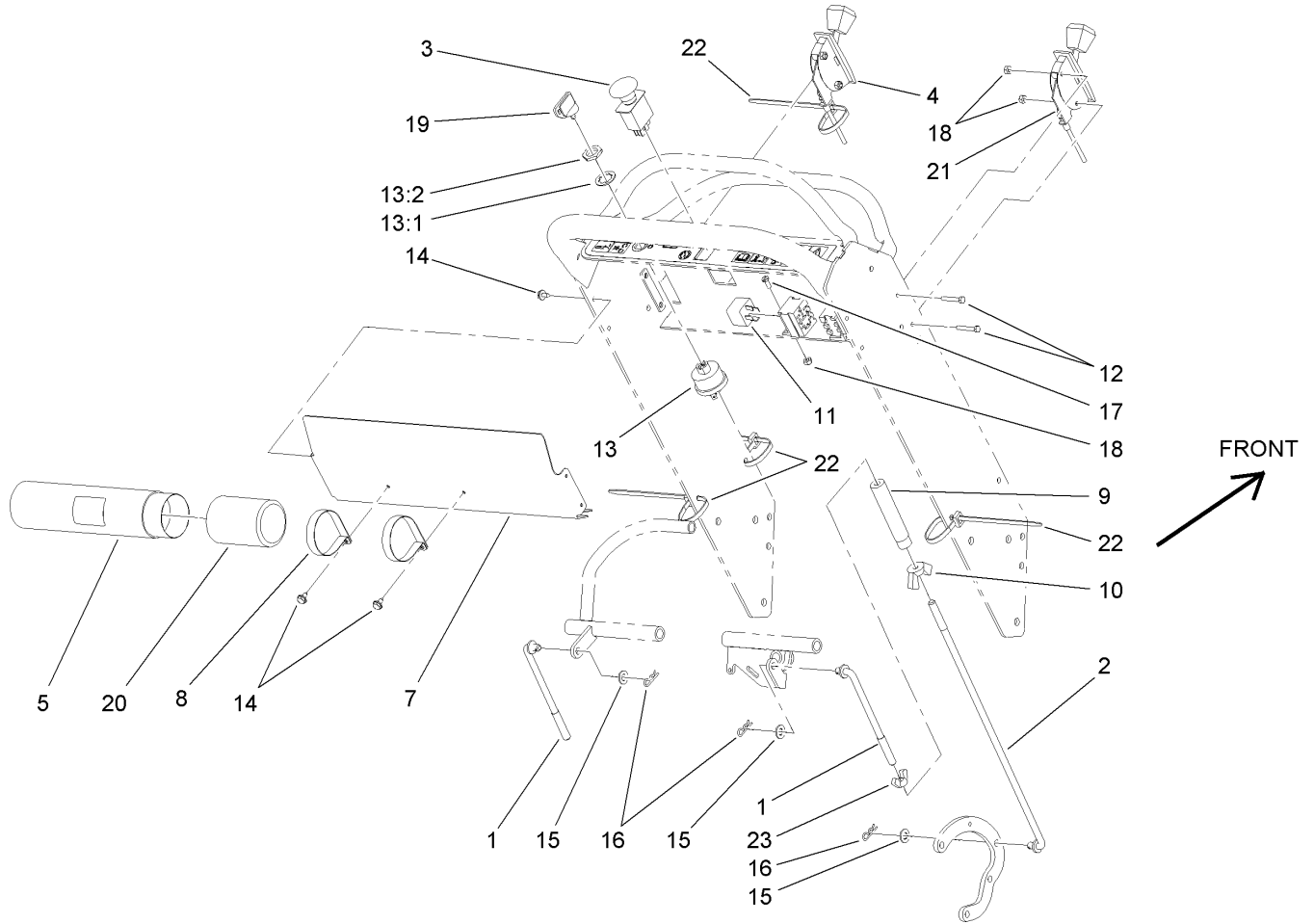

Control Panel Assembly

Ref	Part No.	Qty.	Description
1	114-0275	2	Rod-Control, Upper
2	114-0276	2	Rod-Control, Lower
3	114-0279	1	Switch-PTO
4	110-4994	1	Cable-Throttle
5	104-7050	1	Housing-Manual
7	114-0270-03	1	Cover-Panel, Control
8	2412-120	2	R-Clamp
9	95-1504	2	Turnbuckle
10	32103-3	2	Nut-Wing
11	105-4145	2	Relay
12	3290-360	4	Screw-HH
13	29-5560	1	Switch-On / Off
13:1	218-461	1	Nut-HH
13:2	3254-5	1	Washer-Tooth
14	32104-76	6	Screw
15	3256-23	4	Washer-Flat
16	3290-307	4	Pin-Hair
17	32105-8	1	Screw-SHH
18	3296-2	5	Nut-Lock
19	63-8360	1	Key-Ignition
20	104-7048	1	Cap-Housing
21	110-4995	1	Cable-Choke
22	3290-378	4	Tie-Cable
23	114-0281	2	Nut-Wing, LH

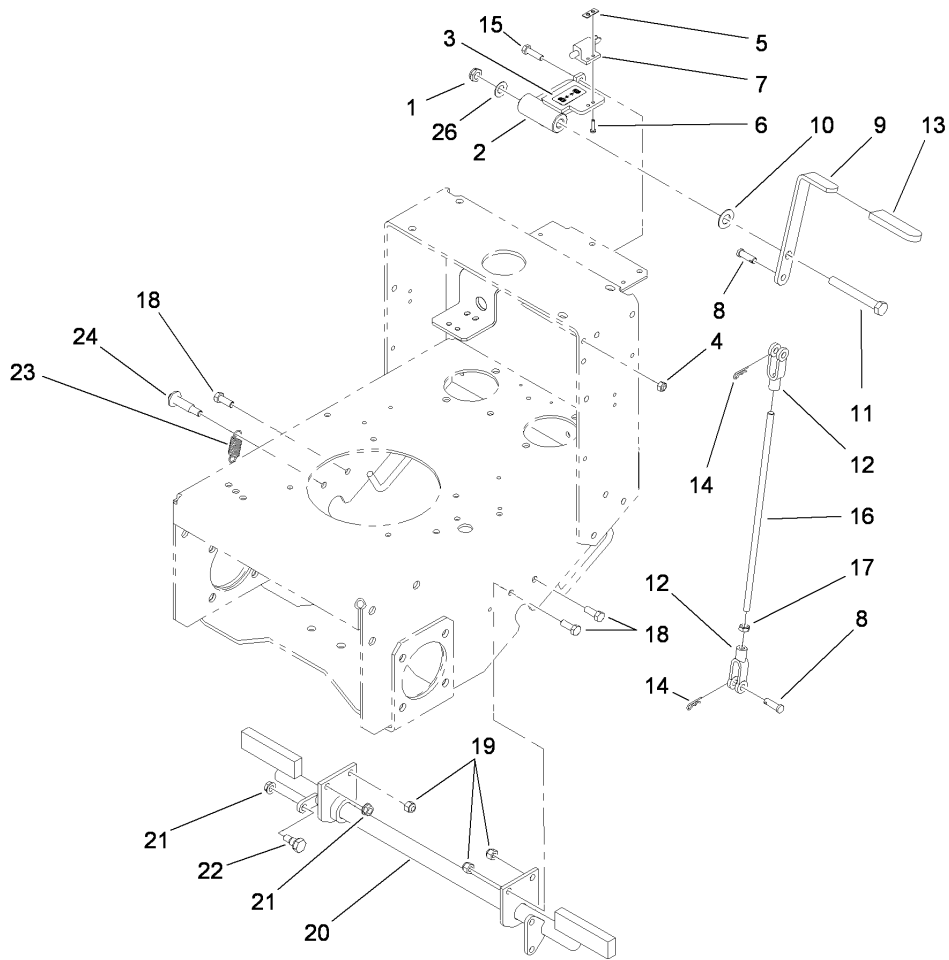

Parking Brake Assembly

Ref	Part No.	Qty.	Description
1	3296-45	1	Nut-Lock, NI
2	112-8716-01	1	Support-Handle
3	112-8721	1	Decal-Brake
4	3296-29	2	Nut-Lock, NI
5	1-633181	1	Plate-Tapped
6	32105-13	2	Screw-HWH
7	1-513152	1	Switch-Closed, Normally
8	1-808285	2	Pin-Clevis
9	106-0671-01	1	Handle-Brake
10	257-7	1	Bearing-Thrust
11	325-17	1	Screw-HH
12	1-633131	2	Yoke-Linkage, Brake
13	1-303020	1	Grip-Lever
14	3290-307	2	Pin-Hair
15	322-6	2	Screw-HH
16	108-2747	1	Rod-Brake
17	3220-3	1	Nut-HJ
18	323-6	3	Screw-HH
19	3296-39	3	Nut-Lock, NI
20	110-4976-01	1	Parking Brake ASM
21	3290-357	2	Nut-HHF, Whiz
22	27-5240	1	Bolt-Shoulder
23	613386	1	Spring-Brake
24	56-6590	1	Bolt-Wheel

Ref	Part No.	Qty.	Description
26	112-9972	1	Washer-Conical, Spring

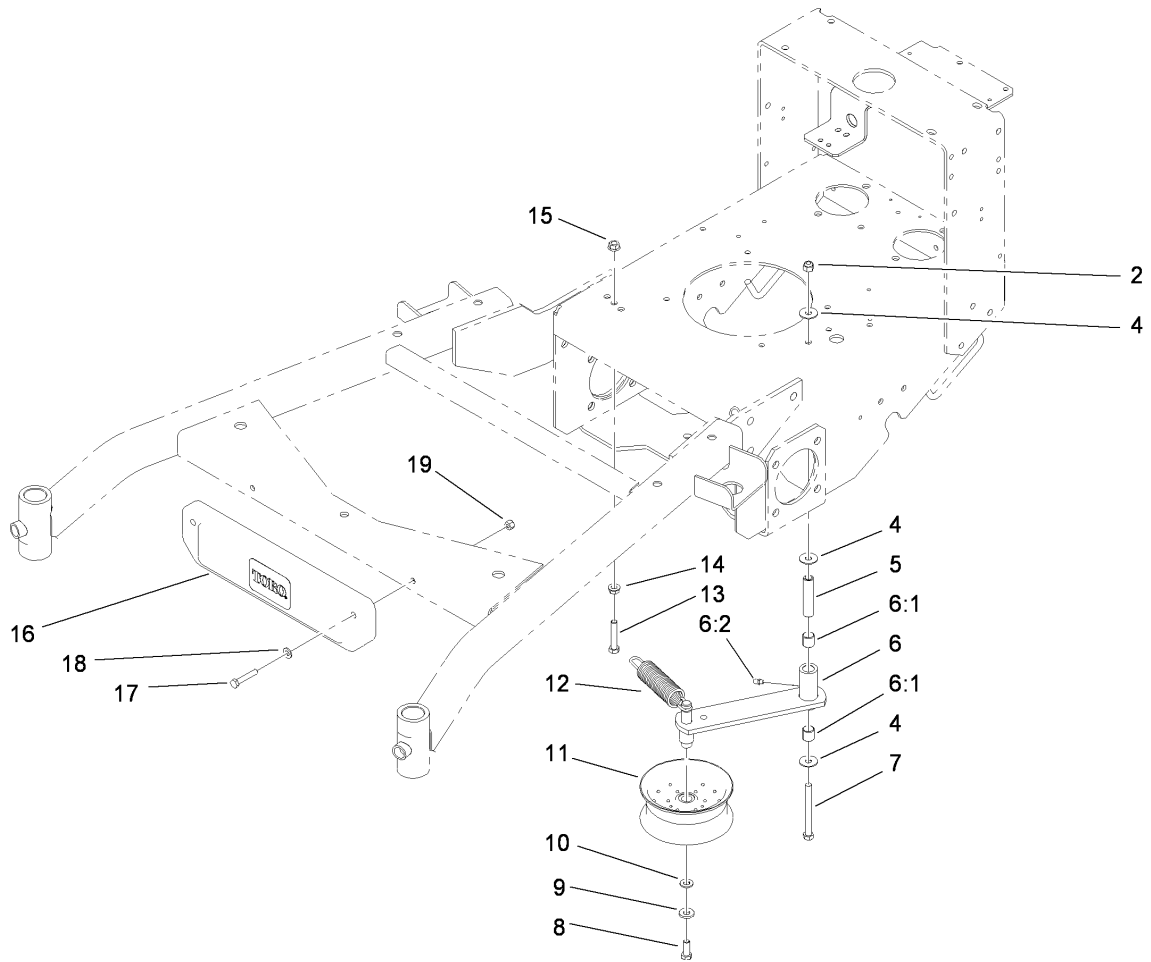

Power-Take-Off Idler and Weight Assembly

Ref	Part No.	Qty.	Description
2	3296-39	1	Nut-Lock, NI
4	52-2860	3	Washer
5	104-6377	1	Tube-Idler
6	112-7055	1	Idler Arm ASM
6:1	1-513034	2	Sleeve-Bearing
6:2	302-5	1	Fitting-Grease
7	323-42	1	Screw-HH
8	323-6	1	Screw-HH
9	98-5975	1	Washer-Belleville
10	3256-24	1	Washer-Flat
11	1-413099	1	Pulley-Idler
12	105-8443	1	Spring-Extension
13	323-10	1	Screw-HH
14	3290-357	1	Nut-HHF, Whiz
15	32128-21	1	Nut-HF
16	112-7059-01	1	Weight-Cast
17	322-9	2	Screw-HH
18	3256-23	2	Washer-Flat
19	3296-29	2	Nut-Lock, NI

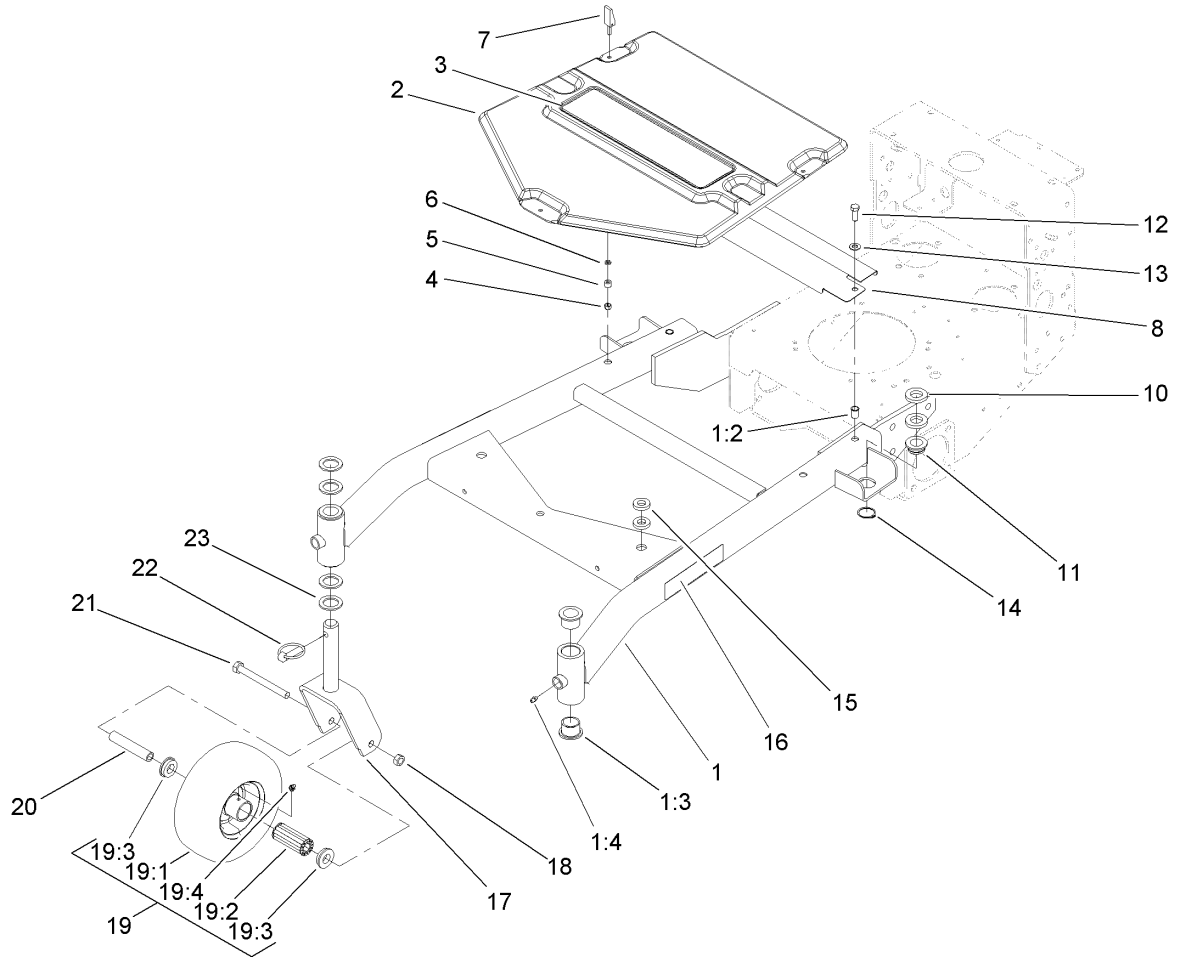

Carrier Frame Assembly

Ref	Part No.	Qty.	Description
1	110-6960	1	Carrier Frame ASM
1:2	32148-9	2	Insert-Nut
1:3	94-1291	4	Bushing
1:4	302-5	2	Fitting-Grease
2	110-6970	1	Cover-Frame, Carrier
3	112-9710	1	Decal
4	1-804254	3	Nut
5	106-6778	3	Bushing-Latch, Swell
6	99-3058	3	Washer
7	106-6777	3	Handle-Latch, Swell
8	110-6971-01	1	Shield-Belt
10	104-1105	4	Spacer-Support, Deck
11	1-513336	2	Bushing-Deck
12	323-6	2	Screw-HH
13	3256-24	2	Washer-Flat
14	32120-33	2	Ring-Retaining
15	1-323539	4	Spacer
16	106-0636	2	Decal
17	105-3159-01	2	Castor Fork ASM
18	32153-5	2	Nut-Lock, Side
19	110-5024	2	Wheel And Tire ASM
19:1	112-7065	1	Tire
19:2	112-7066	1	Bearing-Roller
19:3	1-513810	2	Bushing

Ref	Part No.	Qty.	Description
19:4	302-61	1	Zerk
20	100-6453	2	Bushing-Spanner
21	325-19	2	Screw-HH
22	283-71	2	Pin-Lynch
23	3-6781	8	Washer-Thrust

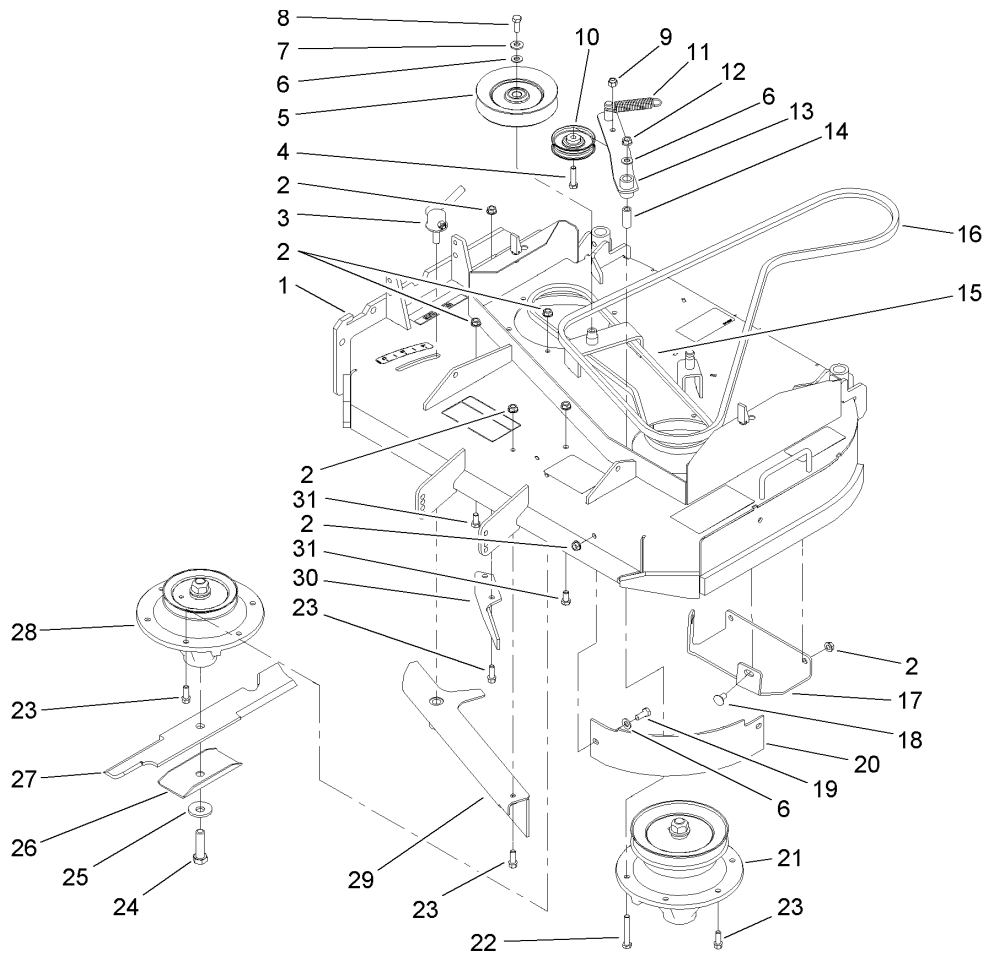

Deck Drive and Baffle Assembly

Ref	Part No.	Qty.	Description
1	112-7085	1	Deck ASM
2	3290-357	22	Nut-HHF, Whiz
3	107-1664	1	Lever ASM
4	323-8	1	Screw-HH
5	1-633166	1	Pulley-Idler
6	3256-24	4	Washer-Flat
7	98-5975	1	Washer-Belleville
8	323-6	1	Screw-HH
9	3296-39	1	Nut-Lock, NI
10	51-3660	1	Pulley-Idler
11	105-2673	1	Spring-Extension
12	32128-21	1	Nut-HF
13	105-0889	1	Idler Arm ASM
14	51-3641	1	Sleeve-Pivot, Idler
15	110-6953	1	Belt-V
16	105-0886	1	Belt-Drive, PTO
17	110-2037-01	1	Plate-Skid
18	3231-1	4	Screw-CARR
19	323-5	2	Screw-HH
20	110-6903-03	1	Baffle-Front, LH
21	110-6950	1	Spindle ASM
22	323-12	1	Screw-HH
23	92-1624	14	Screw
24	51-4060	2	Screw-Blade

Ref	Part No.	Qty.	Description
25	103-0865	2	Washer-Blade Bolt, Heavy
26	108-2727	2	Stiffener-Blade
27	105-7781-03	2	Blade-18 Inch (Hi Flow)
28	110-0728	1	Spindle ASM
29	110-6955-03	1	Adjust Baffle ASM
30	110-0754-01	1	Baffle-Discharge
31	323-4	2	Screw-HH

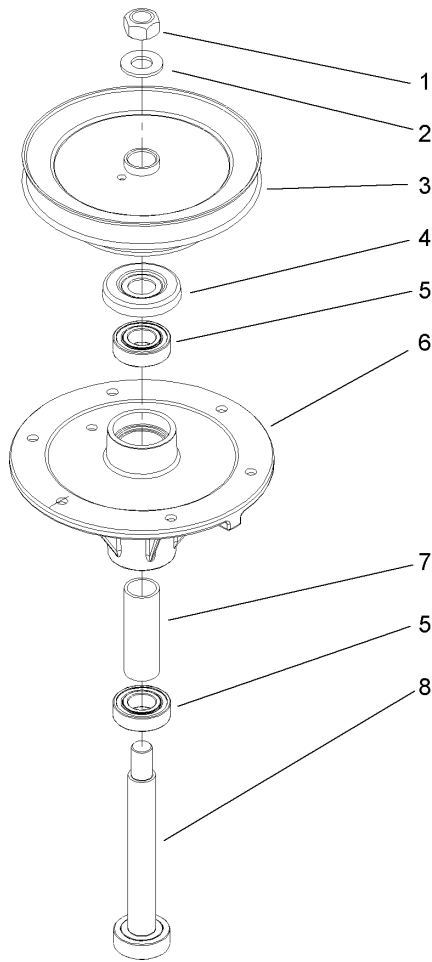

Spindle Assembly No. 110-6950

Ref	Part No.	Qty.	Description
1	3219-7	1	Nut-Hex
2	7-4150	1	Washer
3	110-6951	1	Pulley And Hub ASM
4	106-0873	1	Shield-Bearing
5	104-6325	2	Bearing
6	108-6696	1	Housing-Spindle
7	110-0727	1	Spacer-Bearing
8	110-0725	1	Shaft-Spindle

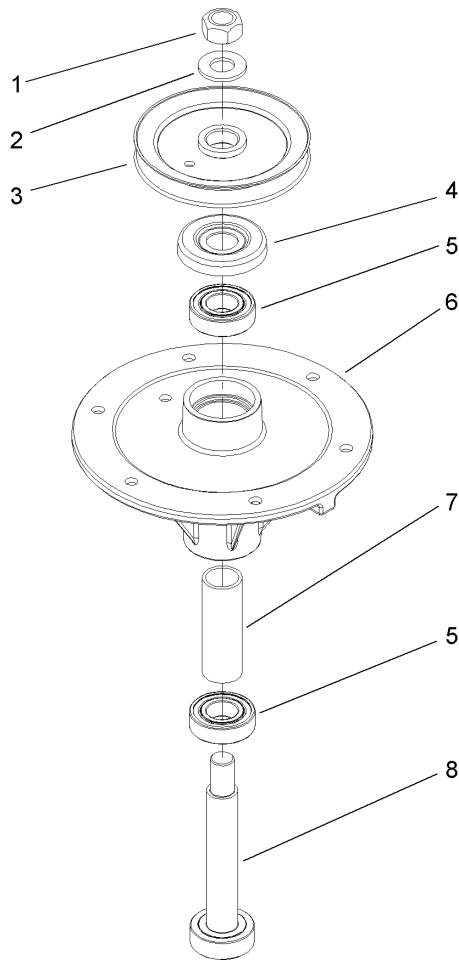

Spindle Assembly No. 110-0728

Ref	Part No.	Qty.	Description				
1	3219-7	1	Nut-Hex				
2	7-4150	1	Washer				
3	104-1181	1	Pulley ASM				
4	106-0873	1	Shield-Bearing				
5	104-6325	2	Bearing				
6	108-6696	1	Housing-Spindle				
7	110-0727	1	Spacer-Bearing				
8	110-0726	1	Shaft-Spindle				

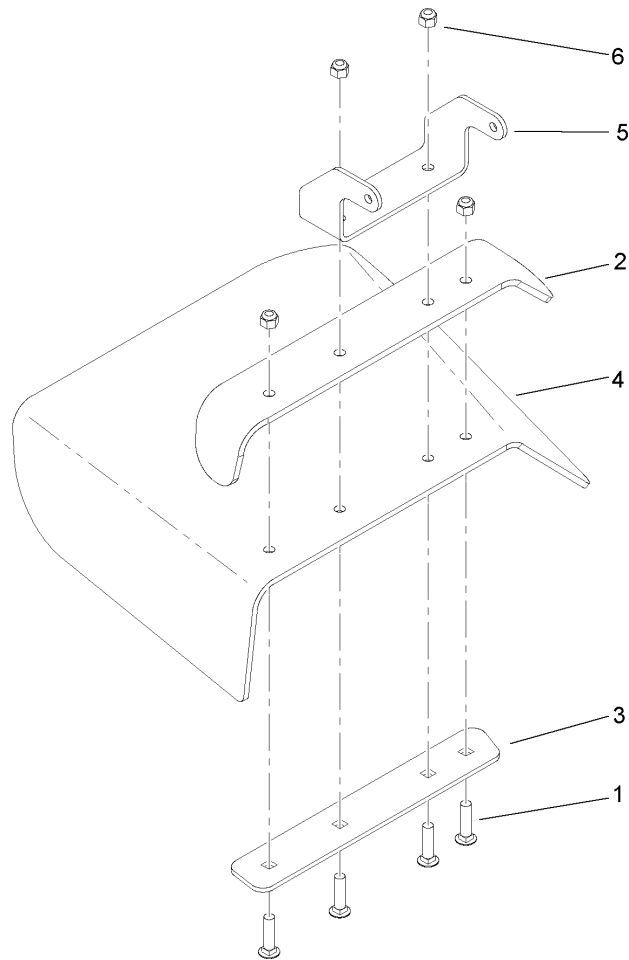

Deflector Assembly No. 110-0790

Ref	Part No.	Qty.	Description
1	3231-4	4	Screw-CARR
2	110-0792-01	1	Deflector
3	110-0793-03	1	Strap-Discharge
4	110-0791	1	Deflector-Rubber
5	107-4164-01	1	Bracket-Mounting, Deflector
6	3296-39	4	Nut-Lock, NI

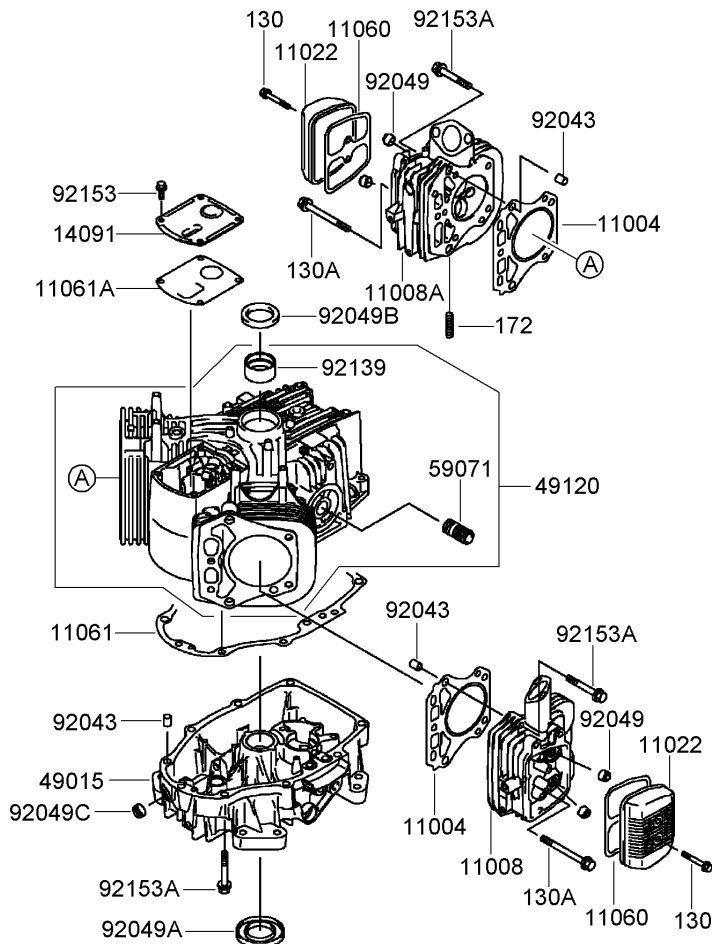

Cylinder and Crankcase Assembly Kawasaki FH430V-AS53

Ref	Part No.	Qty.	Description
③11004	11004-7018	2	Gasket-Head
③11008	11008-7021	1	Head-Cylinder, No. 2
③11008A	11008-7022	1	Head-Cylinder, No. 1
③11022	11022-7003	2	Case-Rocker
③11060	11060-7001	2	Gasket-Case, Rocker
③11061	11061-7007	1	Gasket-Cover, Crankcase
③11061A	11061-7008	1	Gasket-Breather
③14091	14091-7007	1	Cover
③49015	49015-7032	1	Cover-Crankcase
③49120	49120-7015	1	Crankcase
③59071	59071-2079	1	Joint
③92043	92043-7001	6	Pin
③92049	92049-7001	4	Seal-Oil, R V C2 (6X11X10.2)
③92049A	92049-7015	1	Seal-Oil, S D (35X62X8 L HSH)
③92049B	92049-7016	1	Seal-Oil, S D (35X48X8 R HSH)
③92049C	92049-7019	1	Seal-Oil, S O (8X14X5 HSH)
③92139	92139-7008	1	Bushing
③92153	92153-7043	4	Bolt (6X12)
③92153A	92153-7054	17	Bolt (8X50)
③130	130B0640	4	Bolt-Flanged (6X40)
③130A	130CA0875	2	Bolt-Flanged (8X75)
③172	172G0818	4	Bolt-Stud (8X18)

--	--	--	--

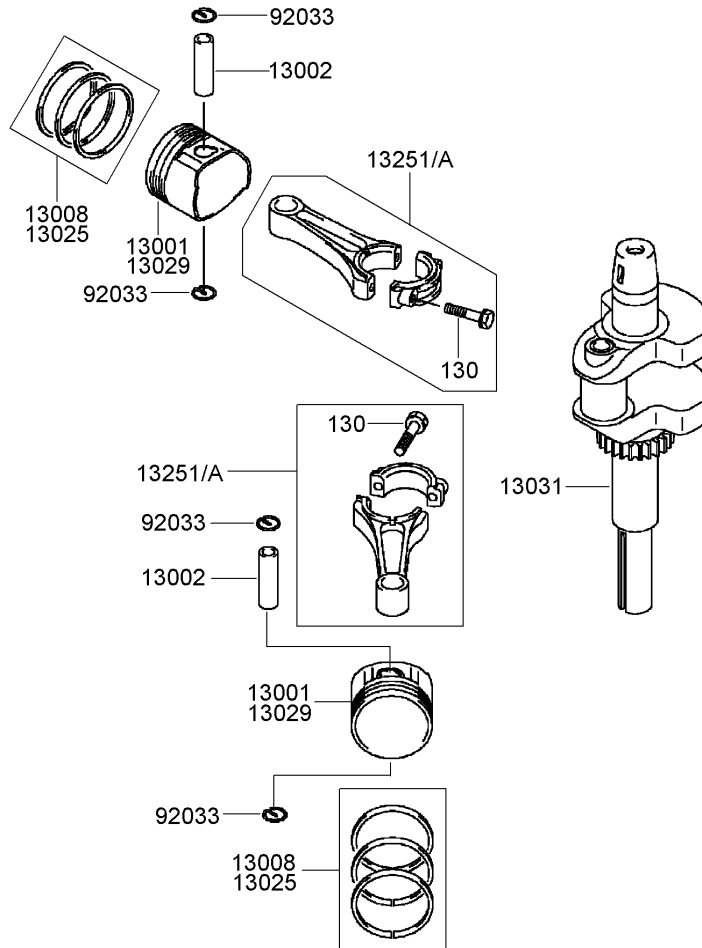

Piston and Crankshaft Assembly Kawasaki FH430V-AS53

Ref	Part No.	Qty.	Description				
● 13001	13001-7022	2	Piston-Engine				
● 13002	13002-7001	2	Pin-Piston				
● 13008	13008-7001	2	Ring Set-Piston				
● 13025	13025-7003	1	Ring Set-Piston (L 0.50)				
● 13029	13029-7005	1	Piston-Engine (L 0.50)				
● 13031	13031-7033	1	Crankshaft				
● 13251	13251-7007	2	Connecting Rod ASM				
● 13251A	13251-7008	2	Connecting Rod ASM (0.50)				
● 92033	92033-7002	4	Ring-Snap				
● 130	130G0630	4	Bolt-Flanged (6X30)				

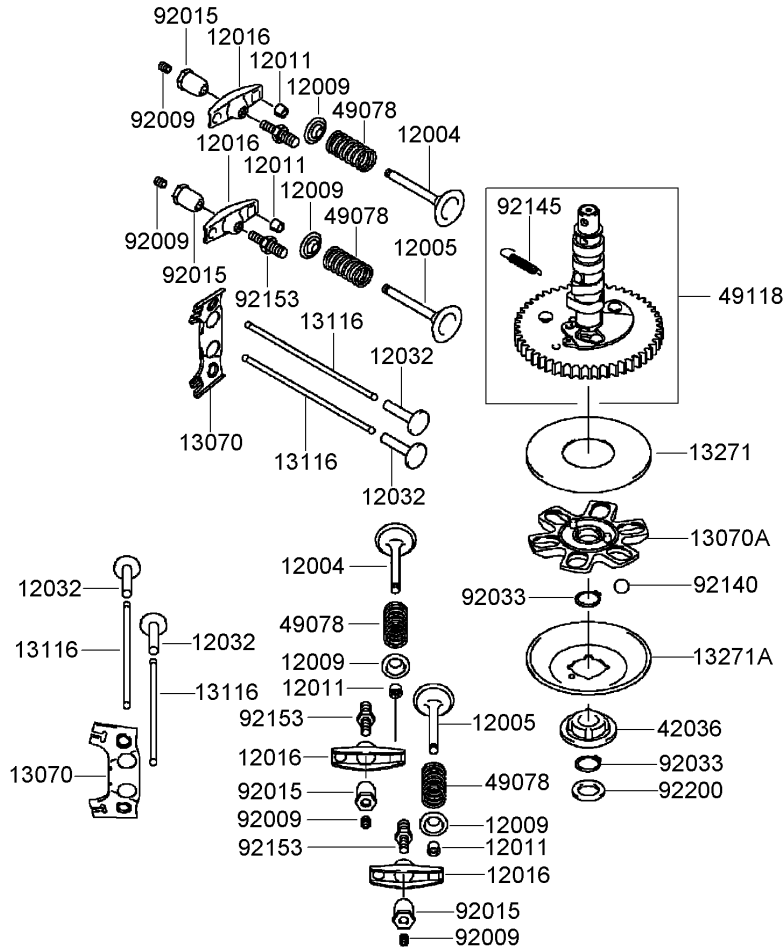

Valve and Camshaft Assembly Kawasaki FH430V-AS53

Ref	Part No.	Qty.	Description
③	12004	2	Valve-Intake
③	12005	2	Valve-Exhaust
③	12009	4	Retainer-Spring, Valve
③	12011	8	Collet
③	12016	4	Arm-Rocker
③	12032	4	Tappet
③	13070	2	Guide
③	13070A	1	Guide
③	13116	4	Rod-Push
③	13271	1	Plate
③	13271A	1	Plate-Governor
③	42036	1	Sleeve
③	49078	4	Spring-Valve, Engine
③	49118	1	Camshaft
③	92009	4	Screw
③	92015	4	Nut
③	92033	2	Ring-Snap
③	92140	6	Ball
③	92145	1	Spring
③	92153	4	Bolt
③	92200	1	Washer

--	--	--	--

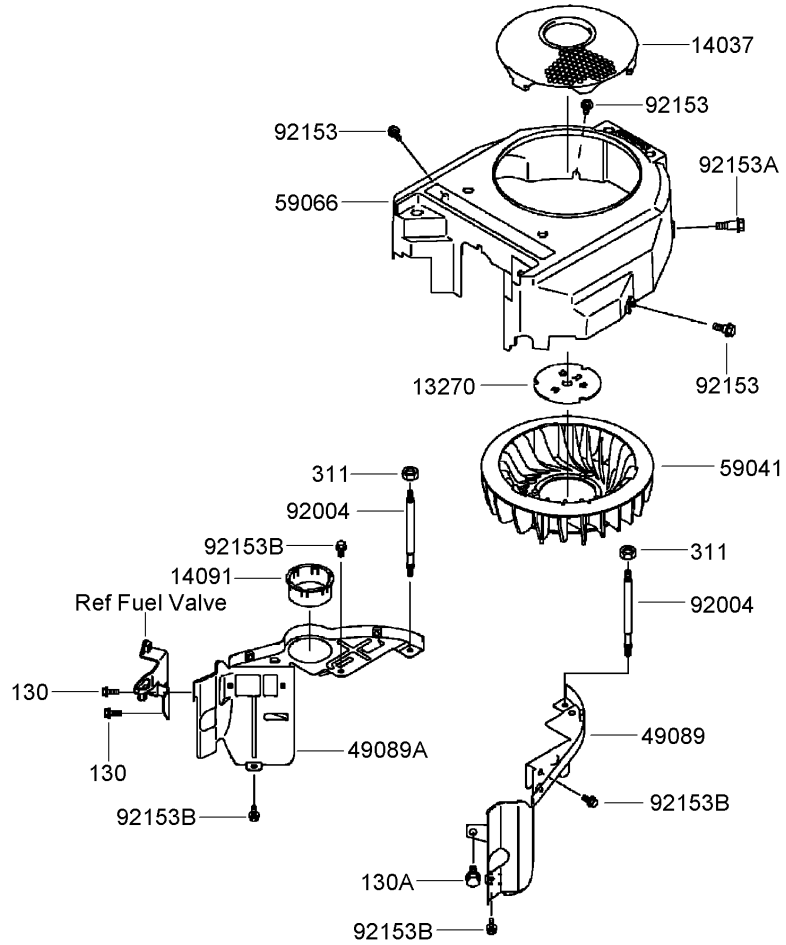

Cooling Equipment Assembly Kawasaki FH430V-AS53

Ref	Part No.	Qty.	Description
● 13270	13270-7007	1	Plate
● 14037	14037-7025-9H	1	Screen
● 14091	14091-7009	1	Cover
● 49089	49089-7044	1	Shroud-Engine
● 49089A	49089-7061	1	Shroud-Engine
● 59041	59041-7012	1	Fan
● 59066	59066-7036	1	Housing-Fan
● 92004	92004-7007	2	Stud
● 92153	92153-7007	3	Bolt
● 92153A	92153-7008	1	Bolt
● 92153B	92153-7043	4	Bolt (6X12)
● 130	130B0616	2	Bolt-Flanged (6X16)
● 130A	130B0816	1	Bolt-Flanged (8X16)
● 311	311F0600	2	Nut-Hex (6Mm)

--	--	--	--

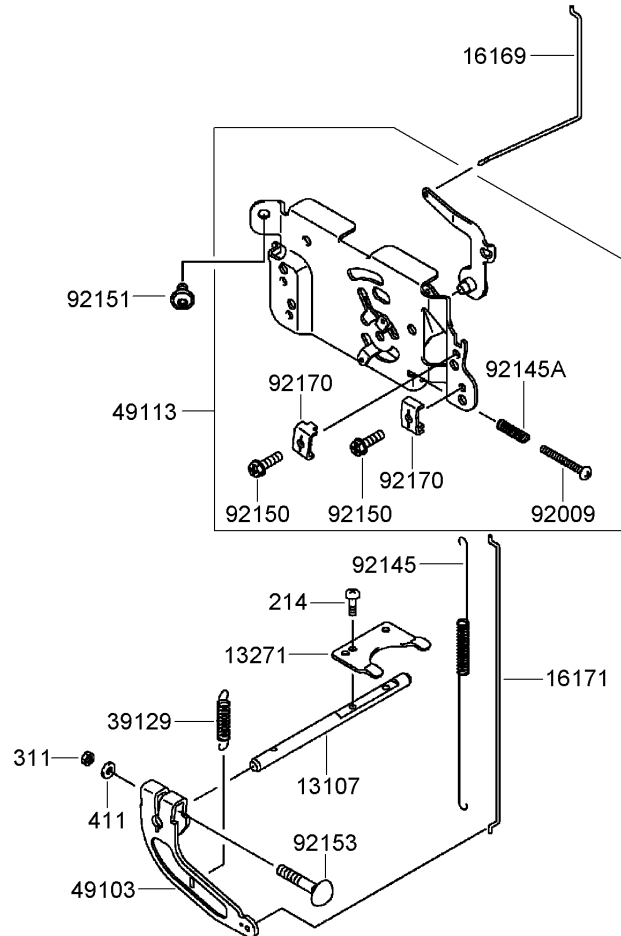

Control Equipment Assembly Kawasaki FH430V-AS53

Ref	Part No.	Qty.	Description				
③13107	13107-7010	1	Shaft				
③13271	13271-7032	1	Plate				
③16169	16169-7012	1	Link-Choke				
③16171	16171-7007	1	Link				
③39129	39129-7003	1	Spring-Governor				
③49103	49103-7004	1	Arm-Governor				
③49113	49113-7024	1	Panel-Control				
③92009	92009-7007	1	Screw (4X35)				
③92145	92145-7003	1	Spring				
③92145A	92145-7005	1	Spring				
③92150	92150-2182	2	Bolt (5X18)				
③92151	92151-7012	2	Bolt (6X12)				
③92153	92153-7033	1	Bolt (6X35)				
③92170	92170-7001	2	Clamp				
③214	214B0408	2	Screw-Pan (4X8)				
③311	311B0600	1	Nut-Hex (6Mm)				
③411	411B0600	1	Washer-Plain (6Mm)				

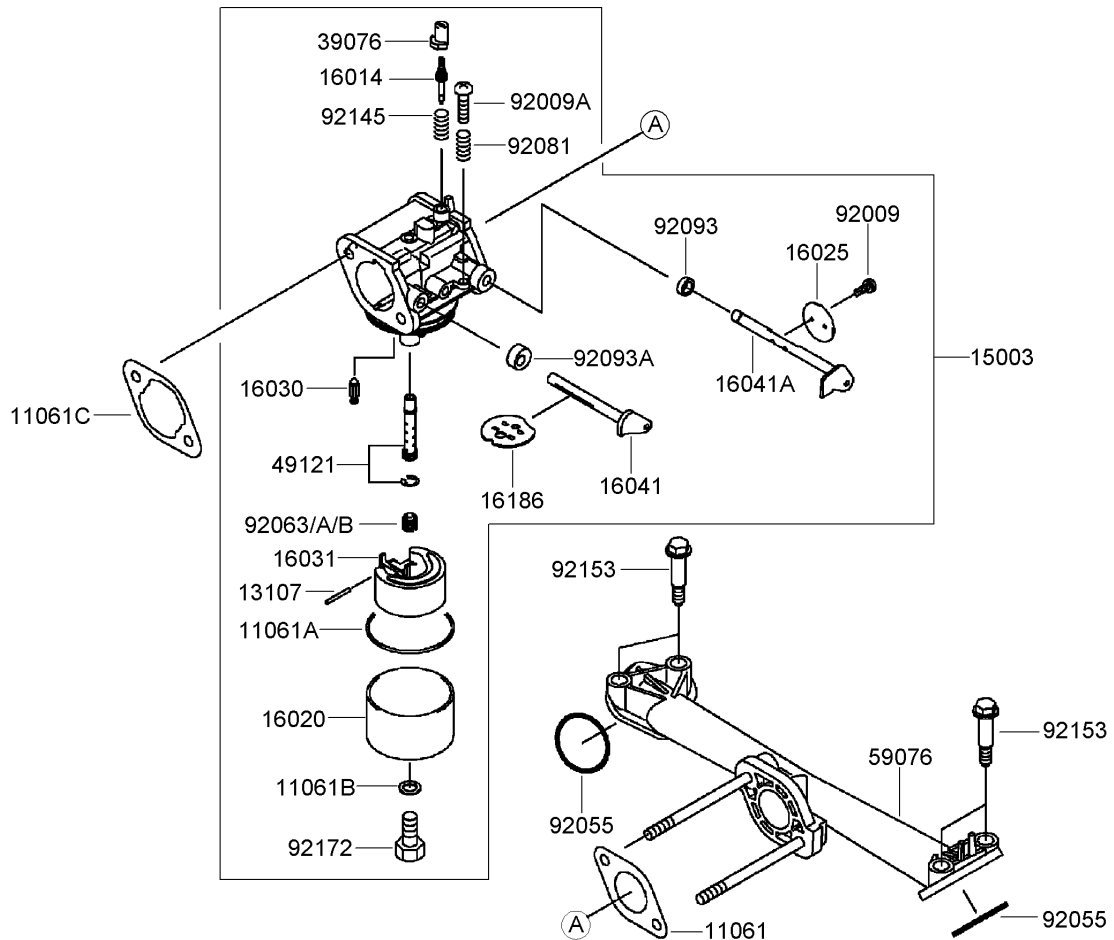

Carburetor Assembly Kawasaki FH430V-AS53

Ref	Part No.	Qty.	Description
● 11061	11061-7004	1	Gasket-Insulator
● 11061A	11061-7009	1	Gasket-Chamber
● 11061B	11061-7010	1	Gasket-Screw
● 11061C	11061-7018	1	Gasket-Cleaner, Air
● 13107	13107-7018	1	Shaft
● 15003	15003-7061	1	Carburetor ASM
● 16014	16014-7002	1	Screw-Pilot, Air
● 16020	16020-7003	1	Chamber-Float
● 16025	16025-7006	1	Valve-Throttle
● 16030	16030-7003	1	Valve-Float
● 16031	16031-7002	1	Float
● 16041	16041-7016	1	Shaft-Choke, Carburetor
● 16041A	16041-7018	1	Shaft-Throttle, Carburetor
● 16186	16186-7002	1	Choke Valve ASM
● 39076	39076-7001	1	Limiter
● 49121	49121-7001	1	Nozzle-Main
● 59076	59076-7005	1	Manifold-Intake
● 92009	92009-2083	2	Screw
● 92009A	92009-2349	1	Screw
● 92055	92055-7007	2	O-Ring (I D 31)
● 92063	92063-7026	1	Jet-Main, No. 88
● 92063A	92063-7028	1	Jet-Main, No. 85
● 92063B	92063-7029	1	Jet-Main, No. 82
● 92081	92081-2234	1	Spring

Ref	Part No.	Qty.	Description
● 92093	92093-2100	1	Seal
● 92093A	92093-7003	1	Seal
● 92145	92145-7015	1	Spring
● 92153	92153-7009	4	Bolt
● 92172	92172-7002	1	Screw

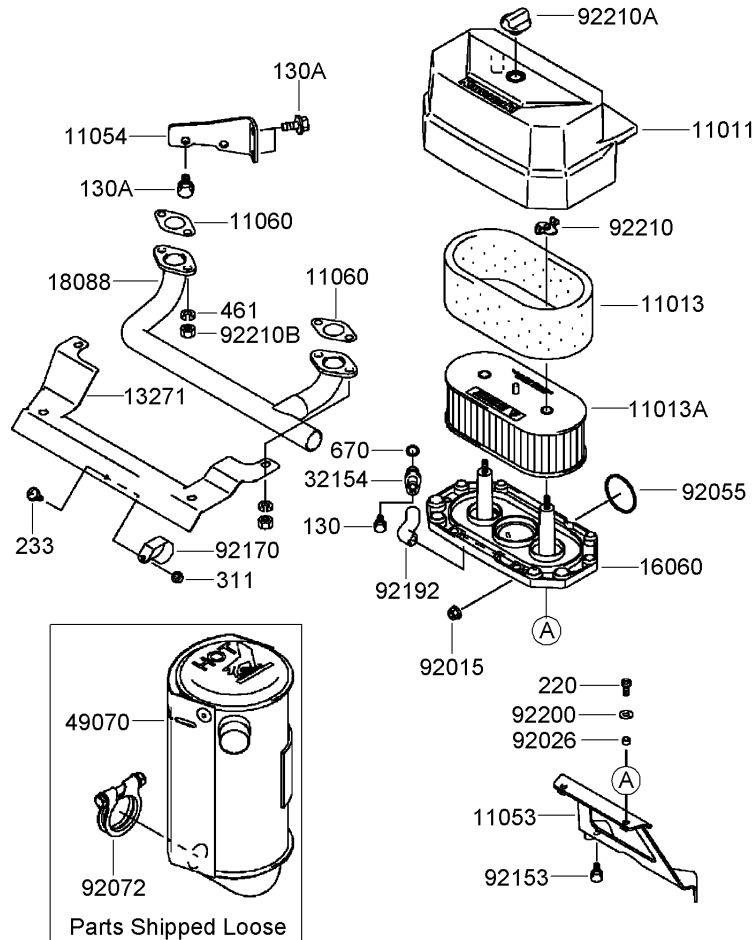

Air Filter and Muffler Assembly Kawasaki FH430V-AS53

Ref	Part No.	Qty.	Description
11011	11011-7045	1	Case-Filter, Air
11013	11013-7025	1	Element-Filter, Air
11013A	11013-7031	1	Element-Filter, Air
11053	11053-7022	1	Bracket
11054	11054-7002-9H	1	Bracket
11060	11060-7021	2	Gasket-Muffler
13271	13271-7022	1	Plate
16060	16060-7016	1	Pipe-Intake
18088	18088-7001	1	Pipe-Exhaust
32154	32154-7006	1	Pipe
49070	49070-7021	1	Muffler
92015	92015-1193	2	Nut
92026	92026-7001	2	Spacer (6.2X7.9X5)
92055	92055-7015	1	O-Ring
92072	92072-7012	1	Band
92153	92153-7043	2	Bolt (6X12)
92170	92170-7002	1	Clamp
92192	92192-7010	1	Tube
92200	92200-2070	2	Washer
92210	92210-7004	2	Nut
92210A	92210-7019	1	Nut
92210B	92210-7027	4	Nut (M8)
130	130B0610	1	Bolt-Flanged (6X10)

Ref	Part No.	Qty.	Description
130A	130B0816	3	Bolt-Flanged (8X16)
220	220B0614	2	Screw-Pan, Cross (6X14)
233	233B0416	1	Screw (4X16)
311	311B0400	1	Nut-Hex (4Mm)
461	461F0800	4	Washer-Spring (8Mm)
670	670B2010	1	O-Ring (10Mm)

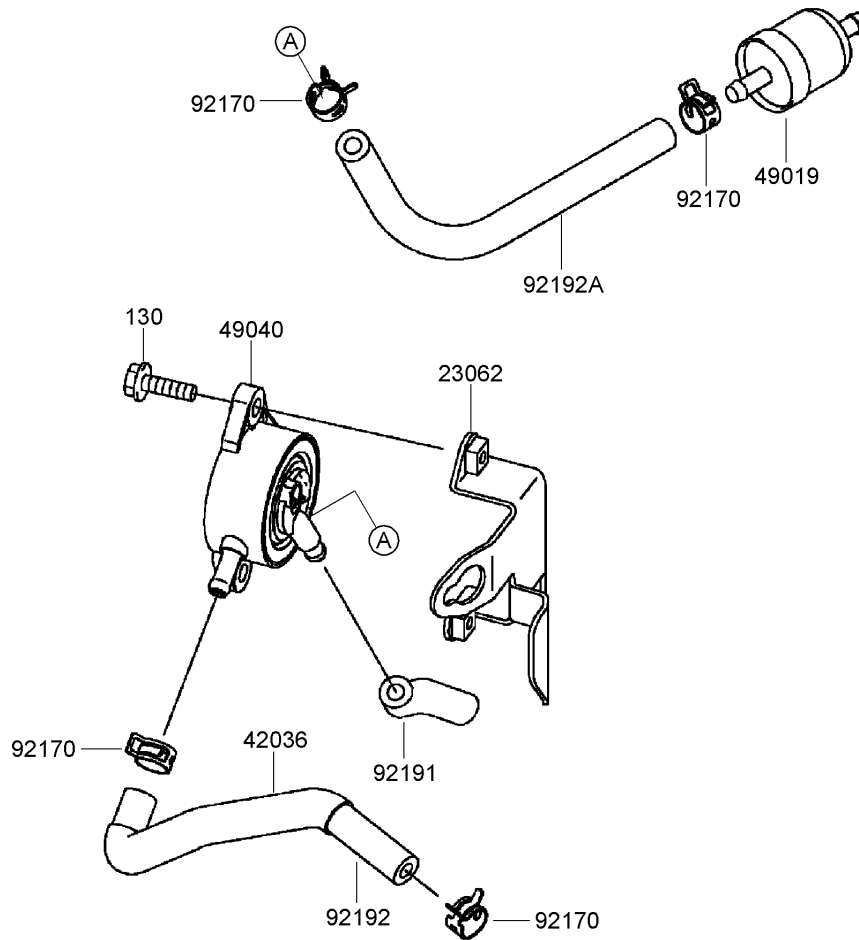

Fuel Tank and Valve Assembly Kawasaki FH430V-AS53

Ref	Part No.	Qty.	Description
①23062	23062-7004-9H	1	Bracket
①42036	42036-7012	1	Sleeve
①49019	49019-7001	1	Filter-Fuel
①49040	49040-7001	1	Pump-Fuel
④92170	92170-2088	4	Clamp
①92191	92191-7002	1	Tube
①92192	92192-7035	1	Tube (6.35X12.7X170)
①92192A	92192-7037	1	Tube (6.35X12.7X160)
②130	130B0620	2	Bolt-Flanged (6X20)

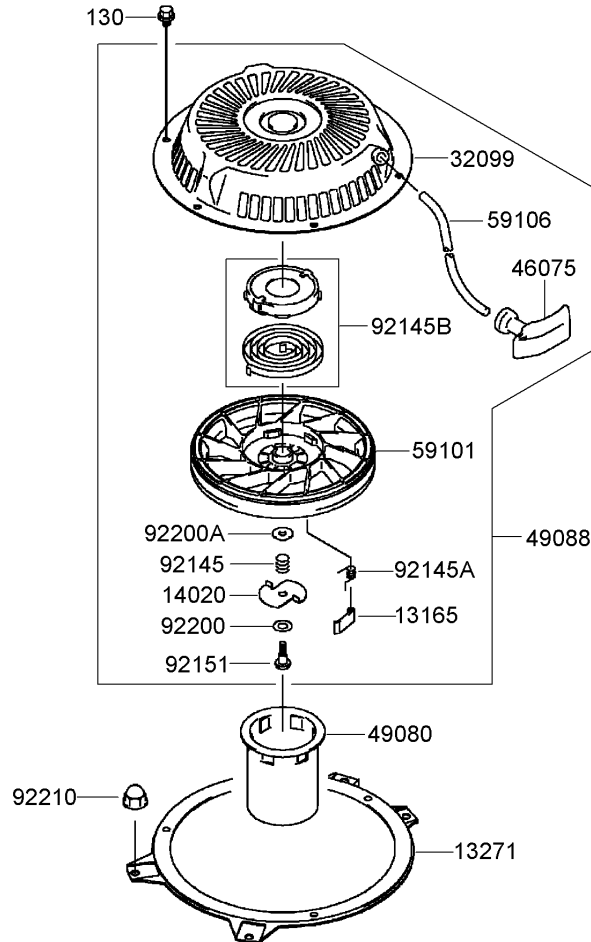

Starter Assembly Kawasaki FH430V-AS53

Ref	Part No.	Qty.	Description				
③13165	13165-7001	2	Pawl-Starter, Recoil				
③13271	13271-7003-9H	1	Plate				
③14020	14020-7001	1	Retainer				
③32099	32099-7002	1	Case-Starter, Recoil				
③46075	46075-7001	1	Grip-Starter, Recoil				
③49080	49080-7001	1	Pulley-Starting				
③49088	49088-7013	1	Starter-Recoil				
③59101	59101-7001	1	Reel-Starter, Recoil				
③59106	59106-7005	1	Rope				
③92145	92145-7006	1	Spring				
③92145A	92145-7007	2	Spring				
③92145B	92145-7008	1	Spring				
③92151	92151-7008	1	Bolt				
③92200	92200-7004	1	Washer				
③92200A	92200-7005	1	Washer				
③92210	92210-0003	4	Nut				
③130	130B0608	3	Bolt-Flanged (6X8)				

Attachments and Accessories

For 30032 - Commercial Walk-Behind Mower, 15HP T-Bar Hydro Drive with 91cm TURBO FORCE Cutting Unit

Product Name	Model/Part
Blade-Recycler, 18 Inch	105-7779-03
Blade-Med Flow, 18 Inch	105-7794-03
Blade-Low Flow, 18 Inch	105-7795-03
Blade-Atomic, 18 Inch	105-7796-03
Blade-Hi-Flow, 18 Inch (6 Pack)	108-1117
Blade-Atomic, 18 Inch (6 Pack)	108-1118
Blade-Lo-Flow, 18 Inch (6 Pack)	110-0406
Blade-Recycler, 18 Inch (6 Pack)	110-0408
Blade-Med-Flow, 18 Inch (6 Pack)	110-0409
36 Inch Bagger Enhancement Kit	110-2026
36 Inch Recycler Kit	110-2080
Weight-Cast	112-7059-01
Soft Bag (3 Bushel)	30104
Tru Trak Sulky	30110

NOTES

