



## Workman<sup>®</sup> 2110 Utility Vehicle

Model No. 07277TC - 280000001 and up.

### Parts Catalog

---

#### Ordering Replacement Parts

To order replacement parts, please supply the part number, the quantity, and the description of each part desired.

#### Understanding Reference Numbers

Each identified part in an illustration has a reference number. The reference number for a part also appears in the parts list, along with other information about the part.

This catalog uses two special reference number formats, one to indicate parts in a service assembly and another to indicate the quantity of a given part in an illustration.

#### Service Assembly Reference Numbers

Parts in service assemblies have reference numbers in the form a:b. The a represents the reference number of the entire service assembly and the b represents a sequential number unique to each part within the service assembly.

For example, a wheel assembly might be identified by reference number 6, the tire by 6:1, the valve by 6:2, and the wheel by 6:3. When you order the assembly identified by reference number 6, you receive all parts identified by reference numbers 6:1, 6:2, and 6:3. However, you may also order any part individually. Reference numbers of this type appear in illustrations and in part lists.

#### Reference Numbers Indicating Quantity

In an illustration, if a reference number indicates more than one part, the reference number has the form nX y. The n represents the quantity of the part, the X is the multiplication symbol, and the y represents the reference number.

For example, in an illustration, the reference number 2X 37 means that two of the parts identified by reference number 37 are indicated.

# Contents

Description	Page	Description	Page
Hood and Fender Assembly	..... 3	Cylinder Assembly Briggs and Stratton 303440-1326-E1	..... 27
Pedal Assembly	..... 4	Crankcase Assembly Briggs and Stratton 303440-1326-E1	..... 28
Shifter Assembly	..... 5	Crankshaft Assembly Briggs and Stratton 303440-1326-E1	..... 29
Frame Assembly	..... 6	Cylinder Head Assembly Briggs and Stratton 303440-1326-E1	..... 30
Seat Base Assembly	..... 7	Oil Filter, Tube and Pump Assembly Briggs and Stratton 303440-1326-E1	..... 31
Front Tire and Steering Assembly	..... 8	Carburetor Assembly Briggs and Stratton 303440-1326-E1	..... 32
Engine and Clutch Assembly	..... 9	Intake Manifold Assembly Briggs and Stratton 303440-1326-E1	..... 33
Drive Clutch Assembly No. 108-7013	..... 11	Governor Assembly Briggs and Stratton 303440-1326-E1	..... 34
Starter Generator Assembly No. 99-7108	..... 12	Flywheel Assembly Briggs and Stratton 303440-1326-E1	..... 35
Rear Tire and Transaxle Assembly	..... 13	Blower Housing Assembly Briggs and Stratton 303440-1326-E1	..... 36
Transaxle Assembly No. 107-0360	..... 14	Engine Gasket Set Briggs and Stratton 303440-1326-E1	..... 37
Driven Clutch Assembly No. 99-7104	..... 16	Carburetor Overhaul Kit Briggs and Stratton 303440-1326-E1	..... 38
Left Hand Brake Assembly No. 104-6807	..... 17	Attachments and Accessories List	..... 39
Right Hand Brake Assembly No. 104-6806	..... 18		
Drivetrain Mounting, Battery and Air Cleaner Assembly	..... 19		
Air Cleaner Assembly No. 99-7120	..... 20		
Upper Steering Assembly	..... 21		
Steering Gearbox Assembly No. 99-7660	..... 22		
Box and Tailgate Installation Assembly	..... 23		
Box and Tailgate Assembly	..... 24		
Hydraulic Brake Assembly	..... 25		
Master Cylinder Assembly No. 104-6782	..... 26		

## Part Description Abbreviations

Part descriptions in this catalog may include the following abbreviations.

AR. .... as required	HYD. .... hydraulic
ASM. .... assembly	LH. .... left hand
BBC. .... blade brake clutch	NI. .... nylon insert
CARR. .... carriage	NPTF. .... national pipe thread fine
DEG. .... degrees	PFH. .... phillips flat head
EXT. .... external	PPH. .... phillips pan head
FH. .... flat head	PPHTF. .... phillips pan head thread forming
GA. .... gauge	PRH. .... phillips round head
HD. .... heavy-duty	PTH. .... phillips truss head
HF. .... hex flange	PTO. .... power-take-off
HH. .... hex head	RH. .... right hand
HHF. .... hex head flange	ROPS. .... roll-over protection system
HHFTF. .... hex head flange thread forming	SFH. .... slotted fillister head
HJ. .... hex jam	SHH. .... slotted hex head
HLH. .... hex lag head	SHWH. .... slotted hex washer head
HOC. .... height-of-cut	SPH. .... slotted pan head
HSBH. .... hex socket button head	SQH. .... square head
HSFH. .... hex socket flat head	SRH. .... slotted round head
HSH. .... hex socket head	STD. .... standard
HWH. .... hex washer head	TAP. .... self tapping
HWHTF. .... hex washer head thread forming	TTH. .... torx truss head

## Footnotes

- |   |  |
|---|--|
| ❶ Not illustrated                                 | ❷ Not serviced separately                            |
| ❸ Obtain from your local Briggs & Stratton dealer | ❹ Included in Carburetor Overhaul Kit (Ref. No. 121) |
| ❺ Included in Engine Gasket Set (Ref. No. 358)    | ❻ Included in Valve Gasket Set (Ref. No. 1095)       |

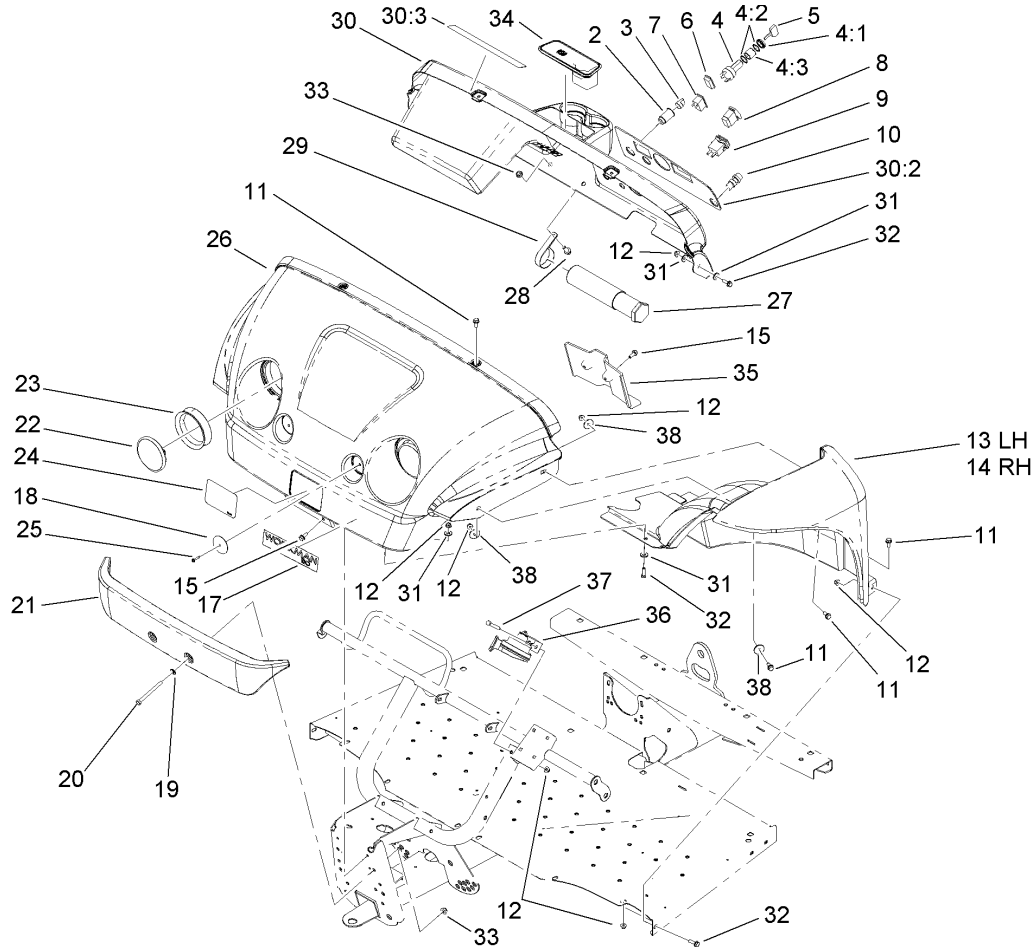

## Hood and Fender Assembly

Ref	Part No.	Qty.	Description
2	99-7411	1	Point-Power
3	99-7416	1	Cap
4	104-6929	1	Switch-Ignition
4:1	104-7042	1	Nut-Switch, Plastic
4:2	104-7019	2	Washer-Lock, Internal
4:3	104-7021	1	Spacer-Switch
5	99-7418	2	Key-Ignition
6	99-7420	1	Plug-Hole
7	99-7410	1	Indicator-Light, Low-Oil Pressure
8	95-8999	1	Switch
9	94-4208	1	Hourmeter
10	18-2830	1	Button-Horn
11	3234-5	14	Screw-HHF
12	104-8300	15	Nut-Flange, NI
13	104-7076	1	LH Fender ASM
14	104-7077	1	RH Fender ASM
15	104-7206	4	Screw-HHF
17	104-7267	1	Decal
18	99-7312	2	Reflector
19	3256-24	2	Washer-Flat
20	323-42	2	Screw-HH
21	99-7733	1	Bumper-Plastic
22	99-7310	2	Headlight
23	99-7311	2	Mount-Headlight

Ref	Part No.	Qty.	Description
24	99-7339	1	Decal
25	32144-89	2	Screw-Forming, Thread
26	104-7003	1	Hood
27	74-0720	1	Tube-Manual
28	3234-11	2	Screw-HHF
29	2412-133	2	R-Clamp
30	107-0700	1	Dash ASM
30:2	107-0699	1	Decal-Panel, Control
30:3	104-6581	1	Decal-Danger
31	3256-3	8	Washer-Flat
32	3234-17	4	Screw-HHF
33	104-8301	4	Nut-Flange, NI
34	104-6930	1	Plug-Rubber
35	104-7075	1	Cover-Channel
36	116749	1	Horn
37	322-11	1	Screw-HH
38	3256-57	6	Washer-Flat





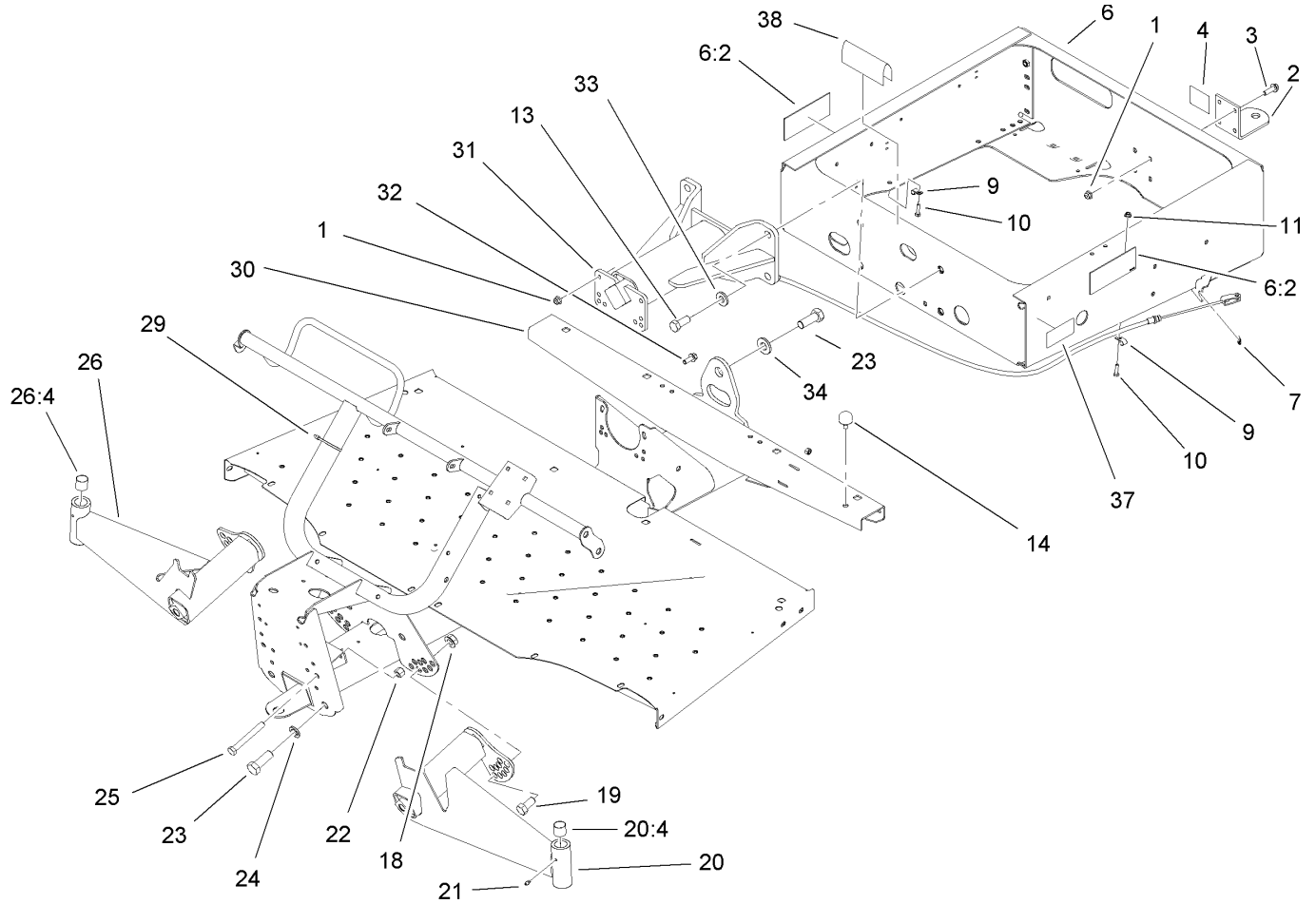

## Frame Assembly

Ref	Part No.	Qty.	Description
1	104-8301	8	Nut-Flange, NI
2	99-7654-03	1	Hitch-Duty, Light
3	3234-24	4	Screw-HHF
4	99-7350	1	Decal-Rating, Hitch (Light Duty)
6	108-3137	1	Rear Frame ASM
6:2	99-7345	2	Decal-Warning
7	32120-47	2	Ring-Retaining, External
9	2412-89	2	Clamp
10	321-6	2	Screw-HH
11	32128-33	2	Nut-HF
13	327-4	4	Screw-HH
14	87-2440	1	Bumper-Rubber
18	32128-54	2	Nut-HF
19	3214-2	2	Screw-HH
20	99-7685	1	LH A-Arm ASM
20:4	3-0348	2	Bushing
21	302-5	2	Fitting-Grease
22	3296-23	2	Nut-Lock, NI
23	328-24	5	Screw-HH
24	3254-7	4	Washer-Lock, Int
25	325-17	2	Screw-HH
26	99-7684	1	RH A-Arm ASM
26:4	3-0348	2	Bushing
29	3290-379	12	Tie-Cable

Ref	Part No.	Qty.	Description
30	104-7197-03	1	Front Frame ASM
31	99-7700	1	Pivot Yoke ASM
32	3234-11	4	Screw-HHF
33	99-7667	4	Washer-Flat
34	87-3060	1	Washer-Hardened
37	104-6591	1	Decal-Capacity
38	95-5686	1	Trim

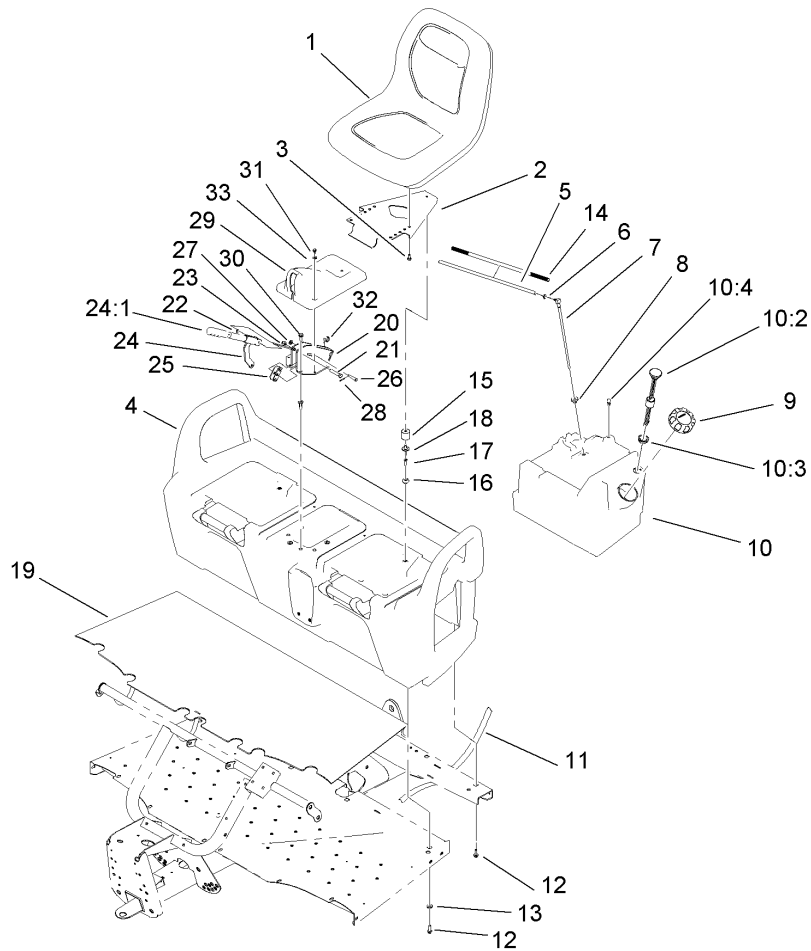

## Seat Base Assembly

Ref	Part No.	Qty.	Description	Ref	Part No.	Qty.	Description
1	112-2923	2	Seat ASM	22	3290-477	1	Washer-Curved
2	99-7829	2	Bracket-Seat	23	3296-39	1	Nut-Lock, NI
3	33114-016	8	Screw-HH	24	104-6842	1	Lever-Brake, Park
4	104-6847	1	Seat Base ASM	24:1	106-7972	1	Grip-Handle
5	108-4582	1	Hose-Fuel	25	87-3480	1	Bracket-Equalizer, Cable
6	2412-98	1	Clamp	26	94-3829	1	Pin-Clevis
7	99-7264	1	Pipe-Stand	27	3256-23	1	Washer-Flat
8	46-6560	1	Bushing	28	3272-6	1	Pin-Cotter
9	95-4192	1	Unleaded Gas Cap ASM	29	104-7014	1	Cover-Brake, Parking
10	99-7323	1	Fuel Tank ASM	30	3234-17	4	Screw-HHF
10:2	99-7262	1	Gauge-Fuel	31	12-3270	2	Screw
10:3	95-8972	1	Grommet	32	32120-47	2	Ring-Retaining, External
10:4	99-7267	1	Vent-Air	33	3256-1	2	Washer-Flat
11	3339-175	1	Strapping-Web, 48 Inch				
12	3234-17	8	Screw-HHF				
13	88-7200	8	Washer-Flat				
14	99-7129	1	Conduit-Line, Fuel				
15	99-7830	2	Rubber Receptical ASM				
16	99-7833	2	Post-Holding				
17	32108-5	2	Screw-FH				
18	3290-412	2	Rivet				
19	104-6590	1	Mat-Floor				
20	104-6844-03	1	Support-Brake, Park				
21	323-10	1	Screw-HH				

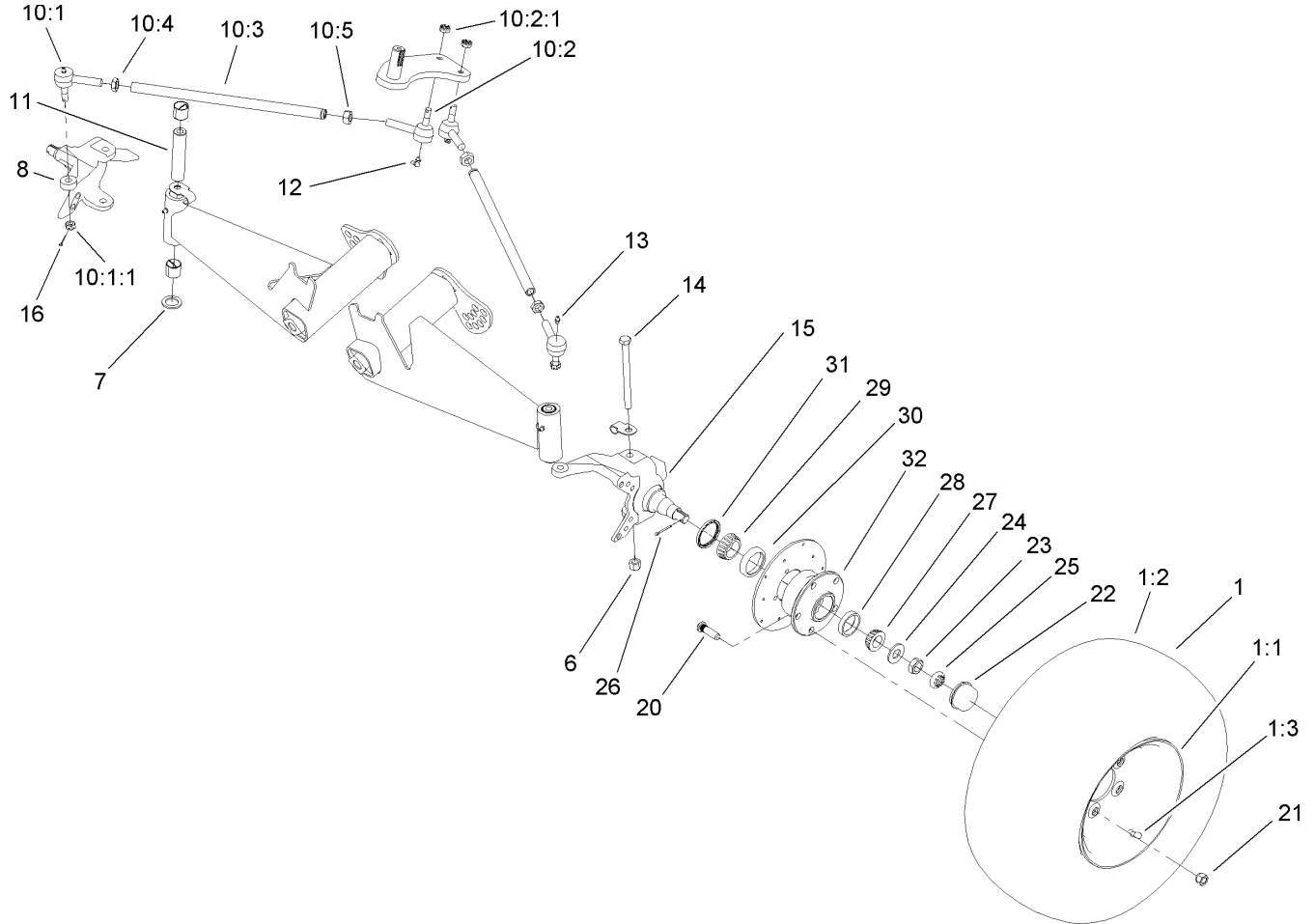

## Front Tire and Steering Assembly

Ref	Part No.	Qty.	Description
1	104-7290	2	Tire And Wheel ASM
1:1	104-7288	1	Wheel
1:2	104-7289	1	Tire
1:3	232-27	1	Stem-Valve
6	3296-23	2	Nut-Lock, NI
7	256-115	2	Washer-Thrust
8	104-6877	1	Spindle-Disc, RH
10		2	Rod-Tie
10:1	112772	1	Joint-Ball, RH
10:1:1	915031	1	Nut
10:2	112771	1	Joint-Ball, LH
10:2:1	915031	1	Nut
10:3	99-7600-03	1	Rod-Tie
10:4	3220-11	1	Nut-Jam
10:5	3218-21	1	Nut-Jam
11	99-7499	2	Sleeve-Kingpin
12	302-60	2	Fitting-Grease, 90 DEG
13	302-5	2	Fitting-Grease
14	325-20	2	Screw-HH
15	104-6876	1	Spindle-Disc, LH
16	3272-7	4	Pin-Cotter
20	10-6830	10	Stud-Type, Drive
21	242-50	10	Nut-Lug
22	241-119	2	Cap-Dust

Ref	Part No.	Qty.	Description
23	3220-7	2	Nut-Jam
24	93-0309	2	Washer-Tab
25	93-0307	2	Nut-Lock, Retainer
26	3272-12	2	Pin-Cotter
27	254-94	2	Bearing-Cone, Tapered
28	254-72	2	Bearing-Cup, Tapered
29	254-106	2	Cone-Bearing, Tapered
30	254-107	2	Cup-Bearing, Tapered
31	108-7019	2	Seal-Shaft
32	104-6809	2	Hub

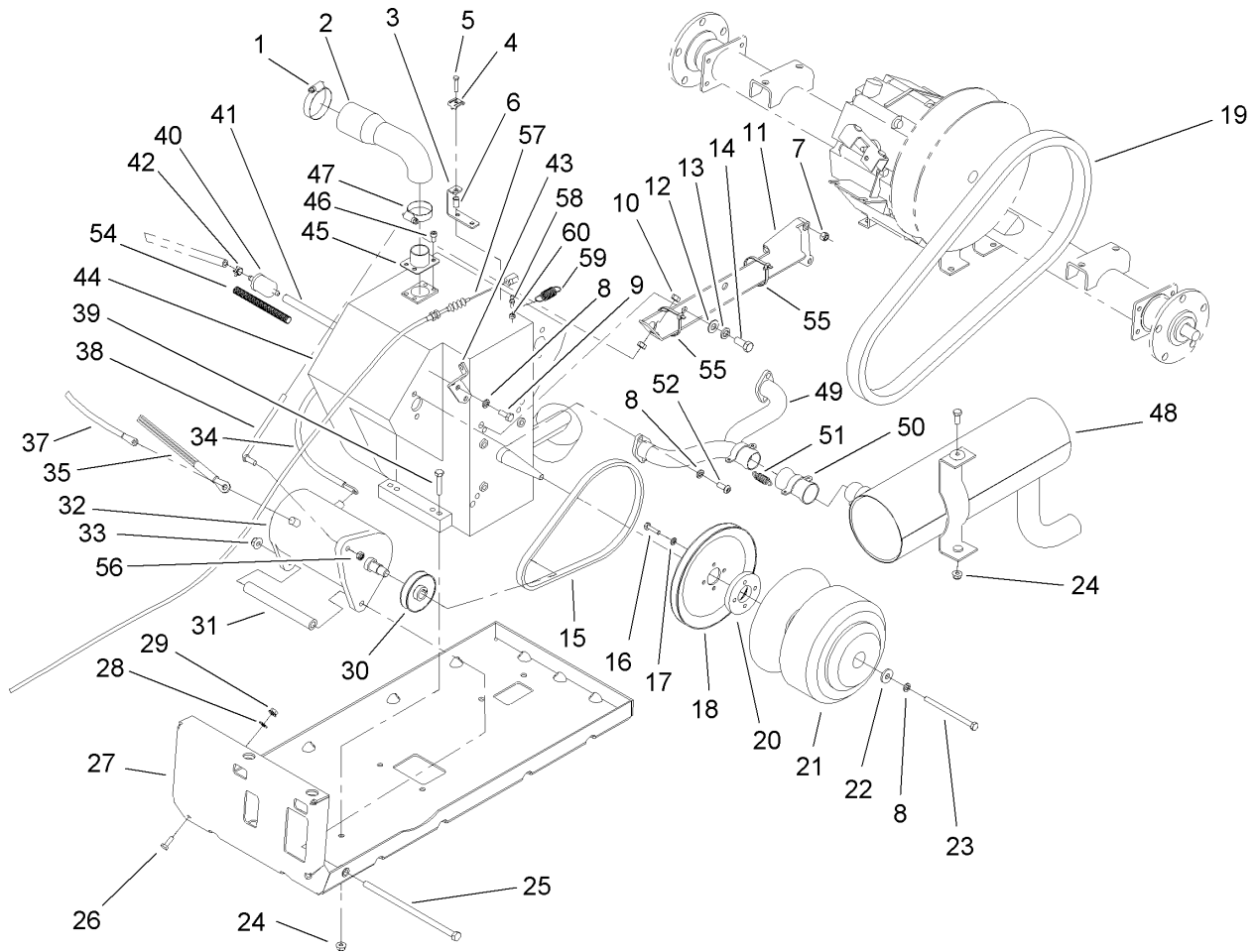

## Engine and Clutch Assembly

Ref	Part No.	Qty.	Description
1	2412-130	1	Clamp-Hose
2	99-7106	1	Hose-Intake
3	107-0319	1	Bracket-Cable
4	81-1690	1	Clamp-Cable
5	3290-432	1	Screw-HH
6	32148-14	1	Insert-Threaded
7	33024-00	2	Nut-Lock
8	3253-4	6	Washer-Lock
9	66-3160	2	Screw-Cap
10	3217-6	2	Nut-Hex
11	104-6631-03	1	Torque Arm ASM
12	3256-25	2	Washer-Flat
13	3253-6	2	Washer-Lock
14	324-4	2	Screw-HH
15	99-7133	1	V-Belt-Starter
16	321-6	4	Screw-HH
17	3253-3	4	Washer-Lock
18	99-7131	1	Pulley-Engine
19	99-7144	1	Belt-Drive
20	99-7064	1	Spacer-Starter
21	108-7013	1	Clutch-Drive
22	5-0838	1	Washer
23	99-7201	1	Screw-HH
24	104-8300	5	Nut-Flange, NI

Ref	Part No.	Qty.	Description
25	99-7203	1	Screw
26	321-4	1	Screw-HH
27	104-6433-03	1	Mount-Engine
28	3255-8	1	Washer-Lock
29	32128-32	1	Nut-HHF
30	99-7130	1	Pulley-Starter
31	99-7053	1	Pivot-Starter
32	99-7108	1	Generator-Starter
33	104-8301	2	Nut-Flange, NI
34	99-7403	1	Cable-Negative
35	99-7437	1	Harness-Wire, Engine
37	104-6926	1	Cable-Positive
38	104-6629	1	Rod-Starter
39	322-8	4	Screw-HH
40	94-2690	1	Filter-Fuel
41	109-0678	1	Hose-Fuel
42	2412-98	3	Clamp
43	104-7152	1	Bracket-Cable, Throttle
44	112-3133	1	Engine-Briggs & Stratton, 303440-1326-E1
45	99-7083	1	Bracket-Intake
46	99-7202	4	Screw-HSH
47	2412-3	1	Clamp-Hose
48	104-6475	1	Muffler-Engine





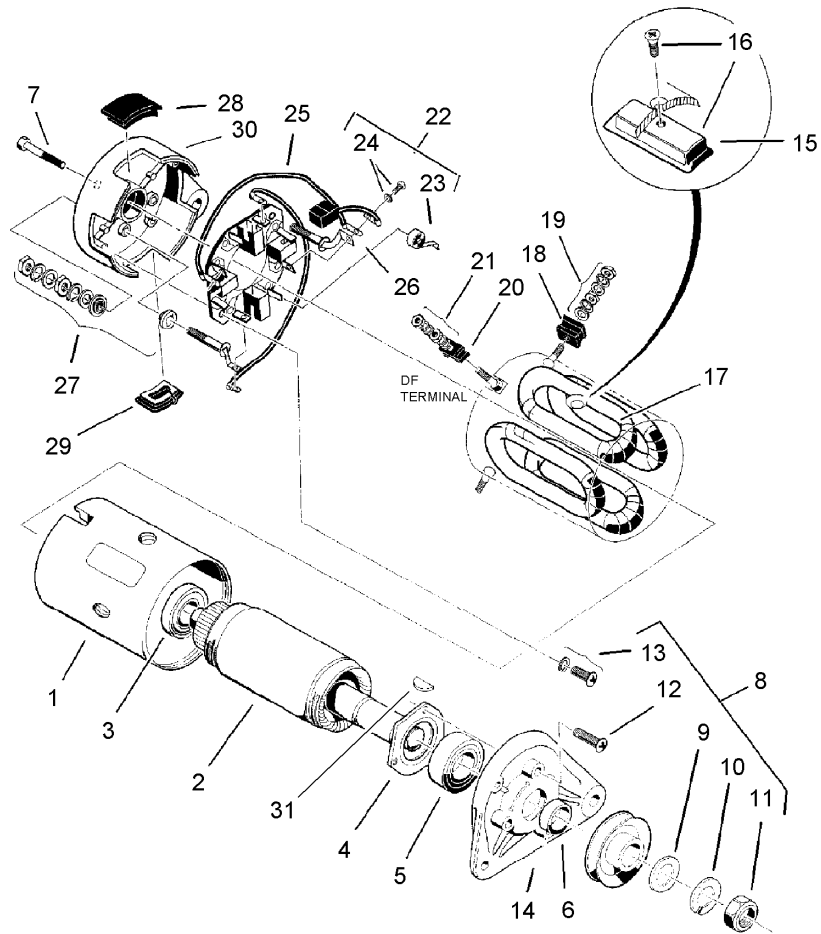

## Starter Generator Assembly No. 99-7108

Ref	Part No.	Qty.	Description
①		1	Yoke
2	104-1210	1	Armature Kit
3	104-1211	1	Bearing-Ball, Rear
4	104-1212	1	Retainer
5	104-1213	1	Bearing-Ball, Front
6	104-1214	1	Spacer
7	104-1215	2	Bolt
⑧		1	Nut & Screw Set
9	104-1216	1	Washer-Plain
10	104-1217	1	Washer-Spring
11	104-1218	1	Nut-Hex
⑫		3	Screw-Flange
13	104-1219	2	Set-Screw
14	104-1220	1	Bracket-Front
⑮		4	Pole
16	104-1221	1	Set-Pole And Screw
17	104-1222	1	Field Stator Coil ASM
⑮		2	F Mold
19	104-1223	2	*obs* Nut & Washer Set
⑳		1	D F Mold
21	104-1224	1	Nut & Washer Set
22	104-1225	1	Brush Holder Kit
23	104-1226	4	Spring-Brush
24	104-1227	1	Brush And Screw Set

Ref	Part No.	Qty.	Description
⑳		2	Brush Connector ASM
㉑		2	A Terminal ASM
27	104-1228	2	Screw And Mold ASM
㉓		1	Cover Set
㉔		1	Cover B
㉕		1	Bracket-Rear
31	3257-3	1	Key-Woodruff

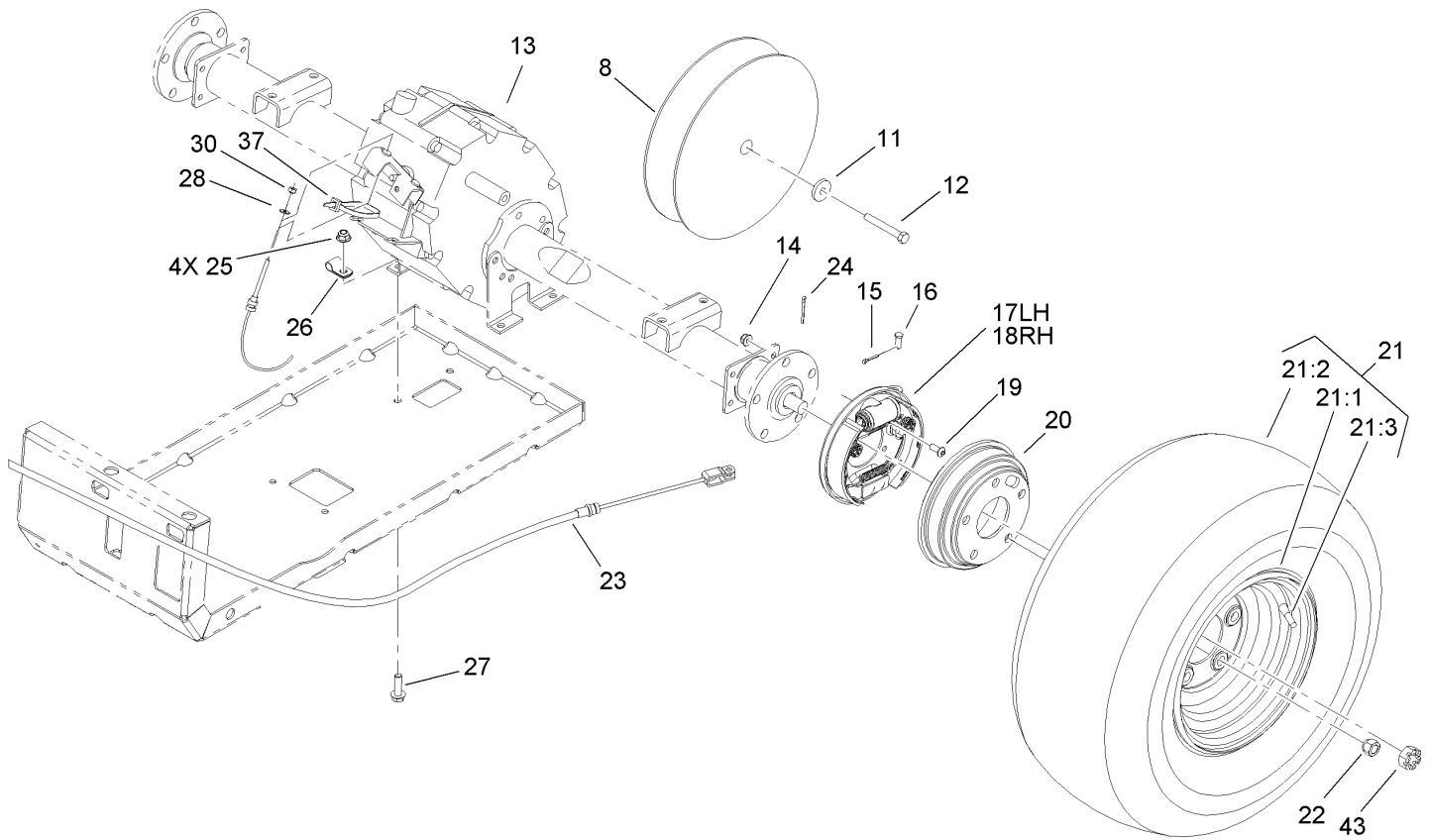

## Rear Tire and Transaxle Assembly

Ref	Part No.	Qty.	Description
8	99-7104	1	Clutch-Driven
11	104-6563	1	Washer-Stepped
12	104-6564	1	Screw-HH
13	107-0360	1	Transaxle
14	104-8300	8	Nut-Flange, NI
15	3272-10	2	Pin-Cotter
16	283-62	2	Pin-Clevis
17	104-6807	1	LH Brake ASM
18	104-6806	1	RH Brake ASM
19	3274-55	8	Screw-HSBH
20	104-6500	2	Drum-Brake
21	104-7282	2	Tire And Wheel ASM
21:1	104-7279	1	Wheel
21:2	104-7281	1	Tire (24 X 12.00-10)2-Ply Turf-Trac R/S
21:3	232-27	1	Stem-Valve
22	242-50	10	Nut-Lug
23	104-6846	2	Cable-Brake, Park
24	3272-42	2	Pin-Cotter
25	104-8301	4	Nut-Flange, NI
26	2412-10	1	R-Clamp
27	3234-24	4	Screw-HHF
28	3256-49	2	Washer-Flat
30	3296-2	2	Nut-Lock

Ref	Part No.	Qty.	Description
37	3290-378	1	Tie-Cable
43	104-1656	2	Nut-Castle

# Transaxle Assembly No. 107-0360

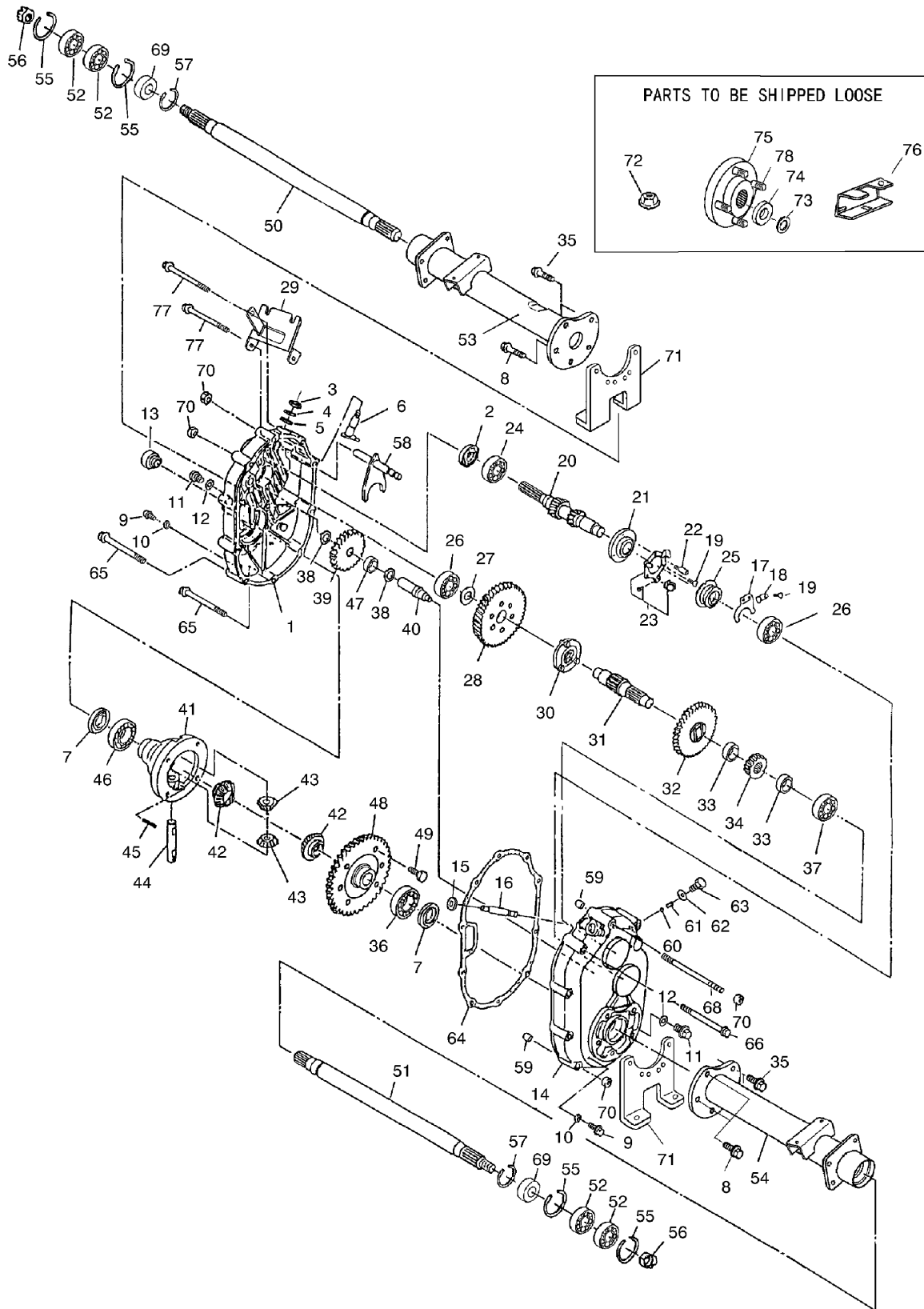

## Transaxle Assembly No. 107-0360

Ref	Part No.	Qty.	Description
1	104-1601	1	Case-LH, Complete
2	104-1602	1	Seal-Oil
3	104-1603	1	Seal-Oil
4	104-1604	1	Ring-Snap
5	104-1605	1	Spacer
6	104-1606	1	Shaft-Selector
7	104-1607	2	Seal-Oil
8	104-1608	4	Bolt-Flange
9	104-1609	2	Plug-Check, Oil
10	104-1610	2	Gasket
11	104-1611	2	Plug-Drain, Oil
12	104-1612	2	Gasket
13	104-1613	1	Plug-Filler, Oil
14	104-1614	1	Case-Complete, RH
15	104-1615	1	Seal-Oil
16	104-1616	1	Shaft-Governor
17	104-1617	1	Fork-Governor
18	104-1618	1	Stopper
19	104-1619	4	Screw And Washer ASM
20	104-7002	1	Shaft-Input, Complete
21	104-1621	1	Base-Governor
22	104-1622	1	Pin-Lock
23	104-1623	1	Unit-Plate, Governor
24	104-1624	1	Bearing-Ball
25	104-1625	1	Sleeve-Governor
26	104-1626	2	Bearing-Ball
27	104-1627	1	Spacer
28	104-1628	1	Gear
29	104-1629	1	Bracket-Wire, Change
30	104-1630	1	Clutch-Pin
31	104-1631	1	Shaft-Center
32	104-1632	1	Gear
33	104-1633	2	Collar
34	104-1634	1	Gear
35	104-1635	6	Bolt-Flange
36	104-1636	1	Bearing-Ball
37	104-1637	1	Bearing-Ball
38	104-1638	2	Spacer
39	104-1639	1	Gear
40	104-1640	1	Shaft-Counter
41	104-1641	1	Case-Differential
42	104-1642	2	Gear-Side, Differential
43	104-1643	2	Pinion-Differential
44	104-1644	1	Shaft-Differential
45	104-1645	1	Pin
46	104-1646	1	Bearing-Ball
47	104-1647	1	Bearing-Needle
48	104-1648	1	Gear
49	104-1649	6	Bolt
50	104-1650	1	Shaft-Axle, LH
51	104-1651	1	Shaft-Axle, RH
52	104-1652	4	Bearing-Ball

Ref	Part No.	Qty.	Description
53	104-1653	1	Case-Axle, LH
54	104-1654	1	Case-Axle, RH
55	104-1655	4	Ring-Snap
56	104-1656	2	Nut-Castle
60	104-1660	1	Ball-Steel
57	104-1657	2	Ring-Snap
58	104-6870	1	Shaft-Shift, Complete
59	104-1659	2	Knock-Pipe
60	104-1660	1	Ball-Steel
61	104-1661	1	Spring
62	104-1662	1	Gasket
63	104-1663	1	Bolt
64	104-1664	1	Gasket
65	104-1665	6	Bolt-Flange
66	104-1666	1	Bolt-Flange
68	104-6866	1	Bolt
69	104-6867	2	Collar
70	33004-00	11	Nut-HF
71	104-1671	2	Bracket-Axle
72	104-1672	1	Nut-Lock
73	104-1673	2	Washer-Spring
74	104-1674	2	Washer
75	104-1675	2	Hub
76	104-6860	1	Lever-Select
77	104-6869	2	Bolt-Flange
78	104-8649	10	Stud





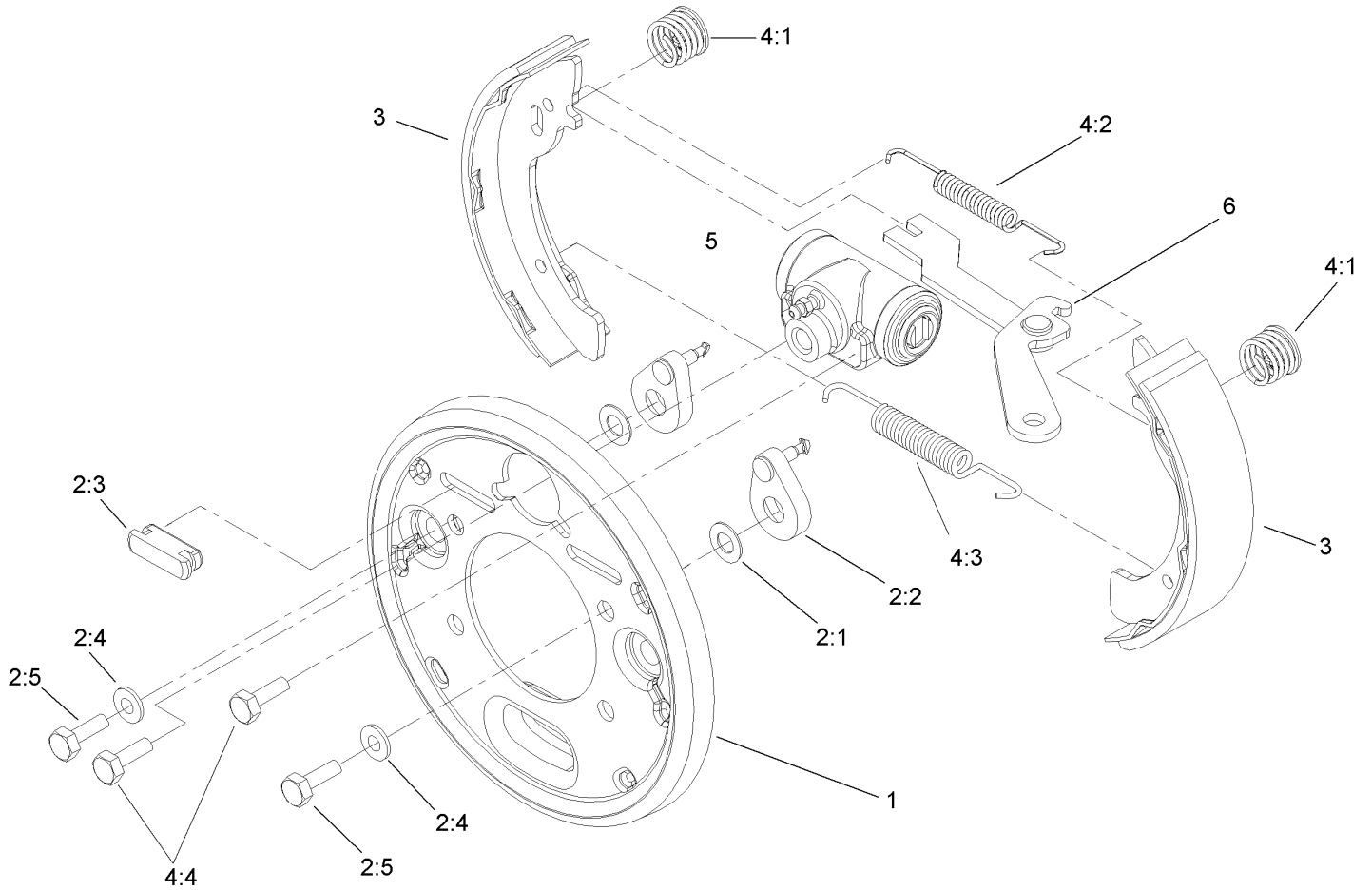

## Right Hand Brake Assembly No. 104-6806

Ref	Part No.	Qty.	Description
1	100-8586	1	Backing Plate ASM
2	104-6820	1	Adjuster Kit
2:1	100-8585	2	Washer-Bellville
2:2	100-8588	2	Adjuster Lever ASM
2:3	100-8584	2	Cover-Dust
2:4		2	Screw
2:5		2	Bolt
3	104-6818	4	Shoe And Lining Kit
4	104-6819	1	Hardware Kit
4:1	100-8583	2	Shoe Hold Down Spring ASM
4:2	100-8581	2	Spring-Upper
4:3	100-8582	2	Spring-Lower
4:4		2	Bolt & Washer
5	104-6824	1	Wheel Cylinder ASM
6	104-6826	1	RH Park Brake Lever ASM

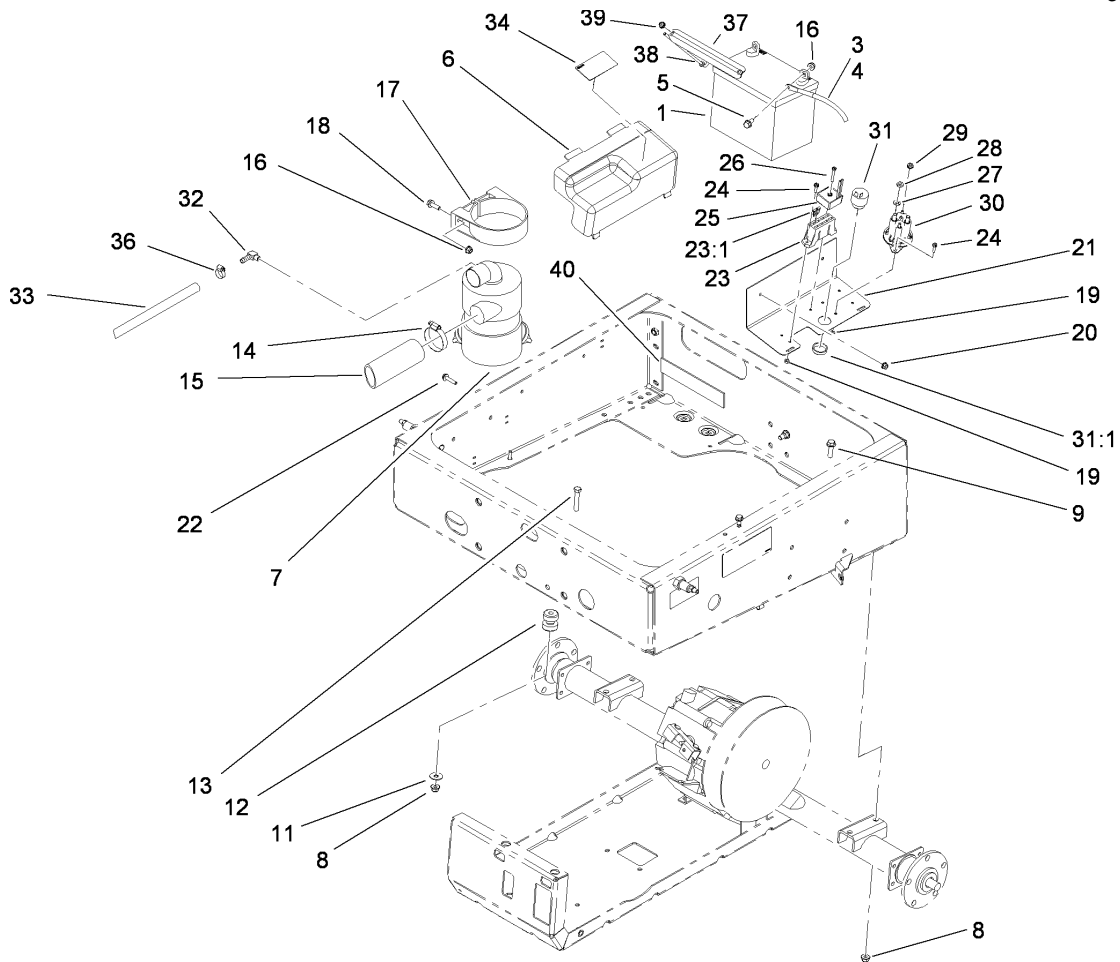

## Drivetrain Mounting, Battery and Air Cleaner Assembly

Ref	Part No.	Qty.	Description
1	104-8162	1	Battery
3	99-7415	1	Cable-Negative
4	99-7404	1	Cable-Positive
5	3234-5	2	Screw-HHF
6	99-7325	1	Cover-Electrical
7	99-7120	1	Air Cleaner ASM
8	104-8301	6	Nut-Flange, NI
9	3234-24	4	Screw-HHF
11	3256-35	2	Washer-Flat
12	95-2596	2	Mount-Iso
13	323-10	2	Screw-HH
14	2412-130	1	Clamp-Hose
15	104-6528	1	Hose-Intake
16	104-8300	4	Nut-Flange, NI
17	95-5806	1	Bracket-Mounting
18	3234-17	2	Screw-HHF
19	3296-2	5	Nut-Lock
20	32128-32	2	Nut-HHF
21	99-7051-03	1	Mount-Component
22	3234-21	2	Screw-Cap
23	107-0669	1	Harness-Wire, Main
23:1	218-578	3	Fuse-10 Amp
23:2	100-4918	2	Diode
24	32105-13	4	Screw-HWH

Ref	Part No.	Qty.	Description
25	104-6927	1	Regulator
26	32105-1	1	Screw-SHH
27	3255-8	2	Washer-Lock
28	3220-2	2	Nut-Jam
29	32149-8	2	Nut-Keps
30	114-3315	1	Solenoid
31	80-9330	1	Alarm-Audio
31:1	104-5107	1	Nut-Plastic, Knurled
32	99-7230	1	Fitting-90 DEG
33	99-7842	1	Hose-Breather
34	99-7352	1	Decal-Information
36	2412-36	2	Clamp-Hose
37	92-5018-03	1	Clamp-Battery
38	95-4042	2	Hook-Retain, Battery
39	104-7201	2	Nut-HF
40	104-7102	1	Pad-Battery



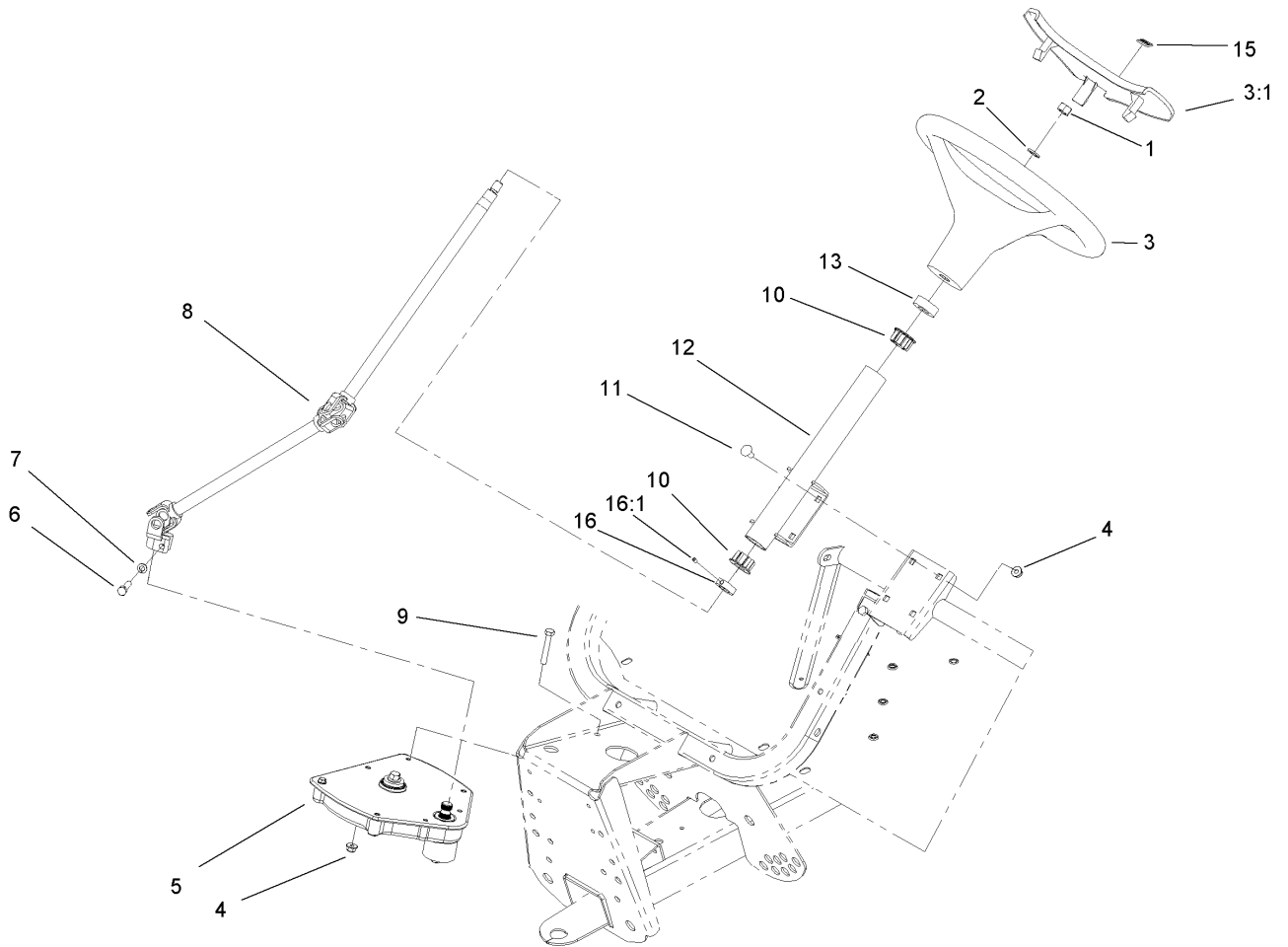

## Upper Steering Assembly

Ref	Part No.	Qty.	Description
1	110-8815	1	Nut-Hex
2	3256-26	1	Washer-Flat
3	98-1471	1	Wheel-Steering
3:1	98-1468	1	Cover-Wheel, Steering
4	104-8300	7	Nut-Flange, NI
5	99-7660	1	Steering Gearbox ASM
6	48-7730	1	Screw-HH
7	3253-4	1	Washer-Lock
8	99-7653	1	Shaft-Steering
9	322-10	3	Screw-HH
10	93-1146	2	Bushing-Steering, Upper
11	3230-1	4	Bolt-CARR
12	99-7651-03	1	Column-Steering
13	21-9260	1	Cover-Dust
15	98-1459	1	Decal
16	111383	1	Collar
16:1	3245-32	1	Screw-HSH

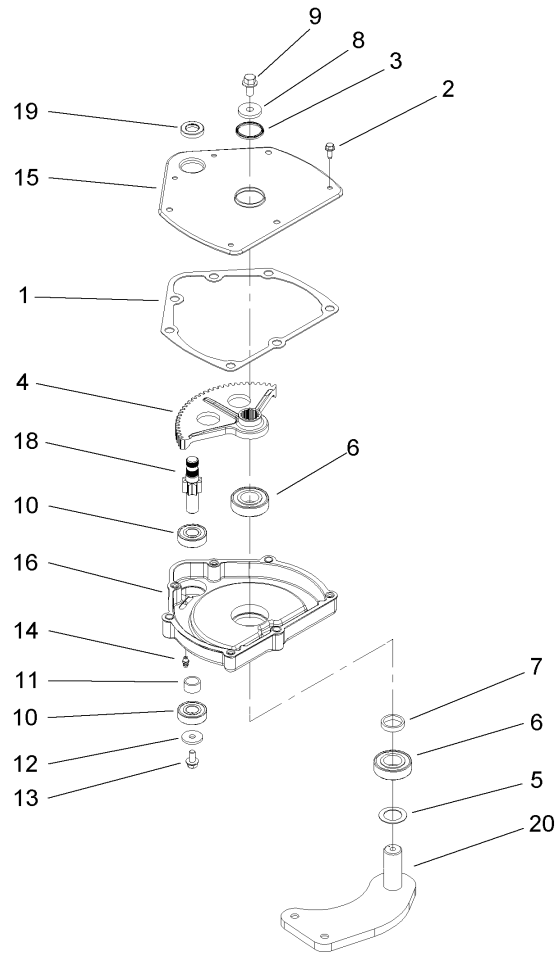

## Steering Gearbox Assembly No. 99-7660

Ref	Part No.	Qty.	Description
1	94-2135	1	Gasket
2	32144-10	4	Screw-HWH
3	103118	1	Seal
4	99-7843	1	Sector-Gear
5	3256-42	1	Washer-Flat
6	251-82	2	Bearing-Ball
7	94-2218	1	Spacer-Shaft, Output
8	104-6563	1	Washer-Stepped
9	104-7156	1	Screw-HHF
10	38-7820	2	Bearing-Ball
11	94-2217	1	Spacer-Shaft, Input
12	1-613235	1	Washer
13	98-3498	1	Screw-HH
14	302-5	1	Fitting-Grease
15	99-7656-03	1	Cover-Housing, Steering
16	99-7658	1	Housing-Steering
18	99-7650	1	Gear-Pinion
19	99-7657	1	Seal-Oil
20	99-7601-03	1	Arm-Pitman



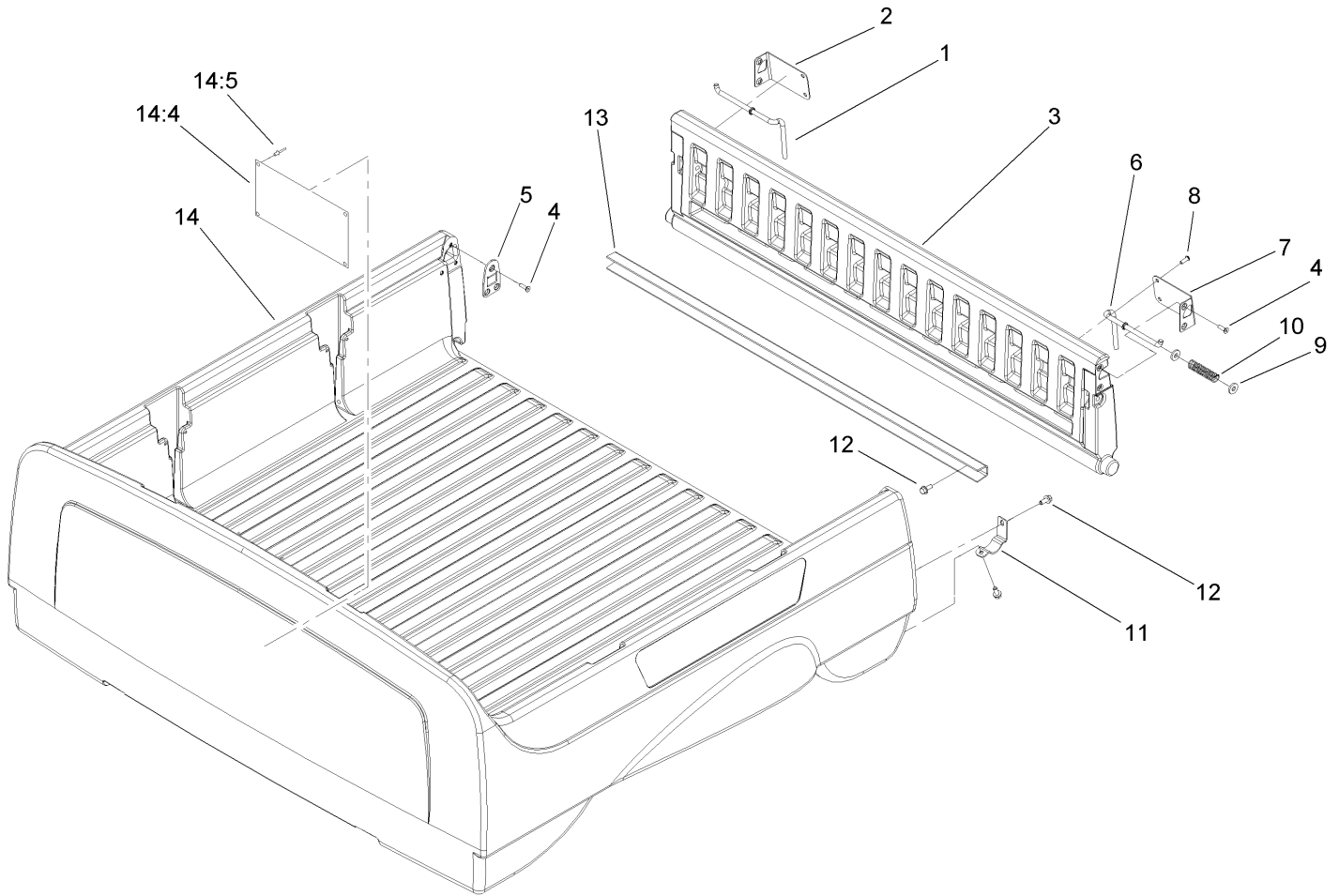

## Box and Tailgate Assembly

Ref	Part No.	Qty.	Description
1	99-7860	1	Rod-Latch, Right
2	99-7858	1	Bracket-Tailgate Latch, Right
3	99-7893	1	Tailgate ASM
4	99-7334	10	Screw
5	99-7852	2	Plate-Striker
6	99-7859	1	Rod-Latch, Left
7	99-7857	1	Bracket-Tailgate Latch, Left
8	99-7335	4	Screw
9	99-7861	4	Washer-Latch
10	61-8880	2	Spring
11	99-7286	2	Bracket-Pivot, Tailgate
12	3234-5	10	Screw-HHF
13	99-7867	1	Channel-Tailgate
14	104-7203	1	Box ASM
14:4	99-7954	1	Decal-No Riders
14:5	3290-415	4	Rivet

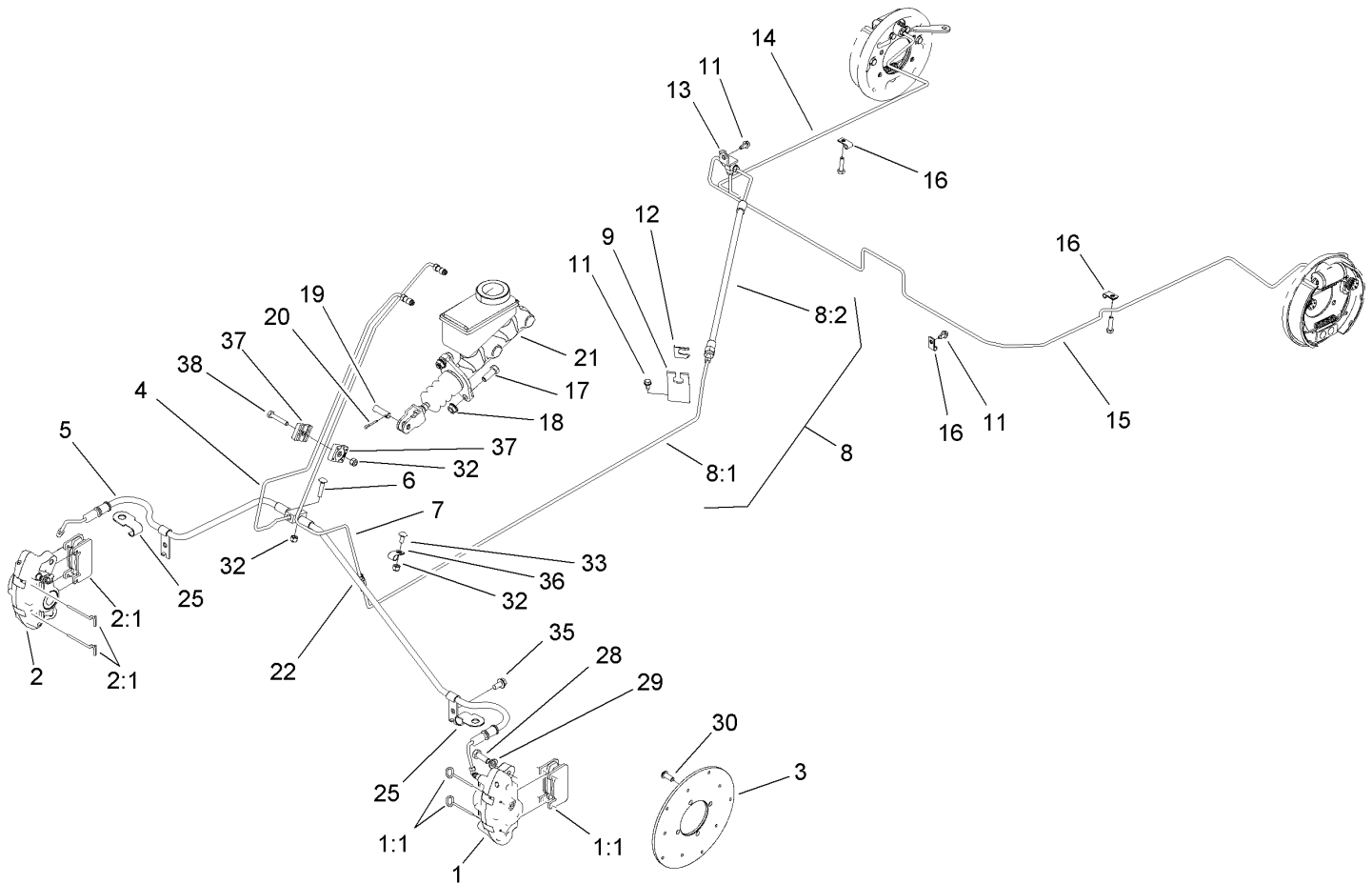

## Hydraulic Brake Assembly

Ref	Part No.	Qty.	Description
1	107-0361	1	Caliper-LH
1:1	107-0708	1	Friction Pad And Pin Kit
2	107-0362	1	Caliper-RH
2:1	107-0708	1	Friction Pad And Pin Kit
3	104-6891	2	Rotor
4	104-6798	1	Tube-Brake, Front
5	104-7256	1	Front Hose ASM
6	3229-3	1	Screw-CARR
7	104-6793	1	Tube-Brake, Rear
8		1	Rear Brake Hose ASM
8:1	104-6794	1	Tube-Brake, Rear
8:2	104-6795	1	Hose-Brake, Rear
9	104-6799	1	Bracket-Hose, Brake
11	12-3270	3	Screw
12	104-7092	1	Clip
13	87-3560	1	Tee
14	104-6796	1	Tube-Brake, Rear (RH)
15	110-2604	1	Tube-Brake, Rear (LH)
16	2412-72	3	Clip-Closed, Insulated
17	323-6	2	Screw-HH
18	3290-357	2	Nut-HHF, Whiz
19	283-2	1	Pin-Clevis
20	3272-10	1	Pin-Cotter
21	104-6782	1	Cylinder-Master

Ref	Part No.	Qty.	Description
22	87-3570	1	Union
25	104-7073	2	Bracket-Hose
28	323-6	4	Screw-HH
29	3253-21	4	Washer-Lock
30	3274-55	8	Screw-HSBH
32	3296-42	3	Nut-Lock, NI
33	3229-11	1	Screw-CARR
35	32144-14	2	Screw-HWHTF
36	2412-89	1	Clamp
37	87-7660	2	Clamp-Tube
38	321-9	1	Screw-HH

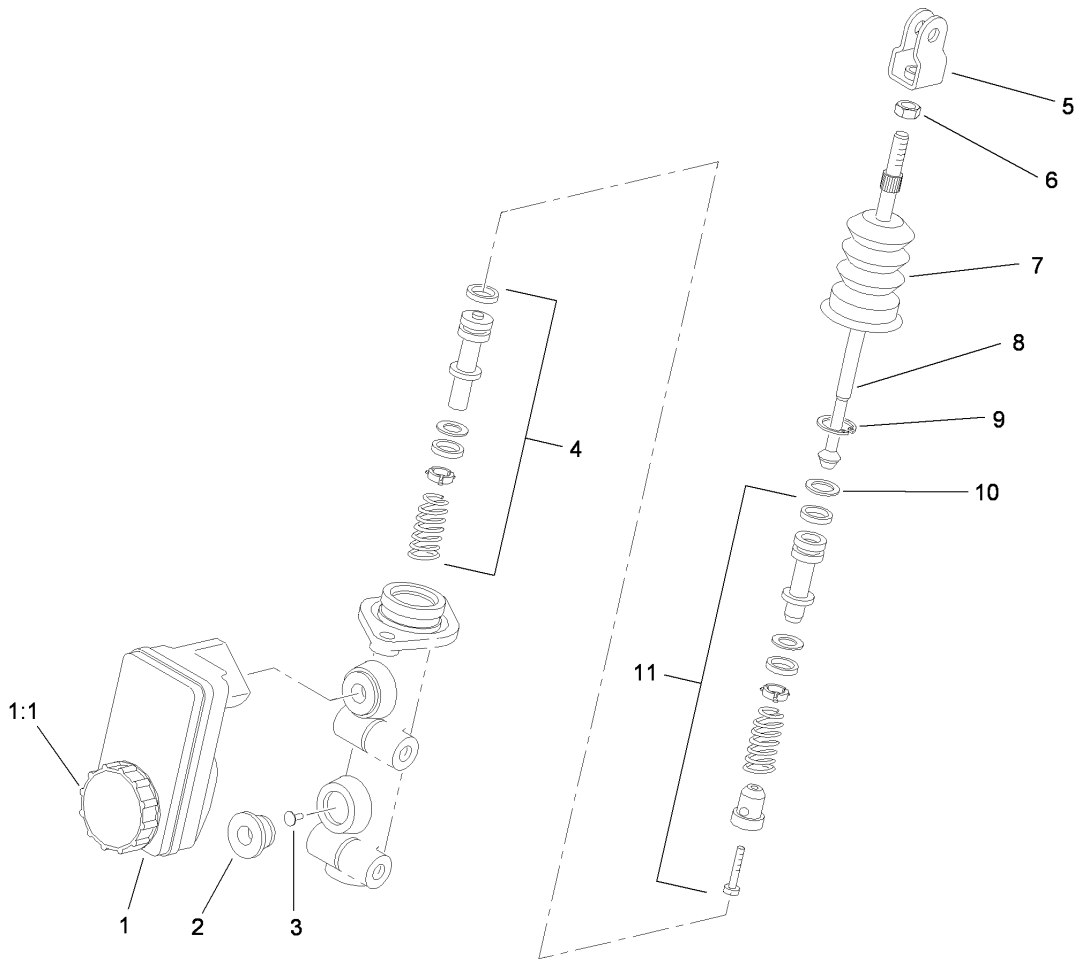

## Master Cylinder Assembly No. 104-6782

Ref	Part No.	Qty.	Description
1	104-6845	1	Reservoir ASM
1:1	92-4112	1	Cap ASM
2	93-8971	2	Seal-Port, Flange
3	92-4103	1	Pin-Stop
4	92-4102	1	Secondary Piston ASM
5	92-4110	1	Clevis
6	21-0360	1	Nut-Hex
7	94-5209	1	Cover-Dust
8	94-5210	1	Rod-Push
9	92-4109	1	Ring-Snap
10	92-4108	1	Retainer-Washer
11	92-4101	1	Primary Piston ASM



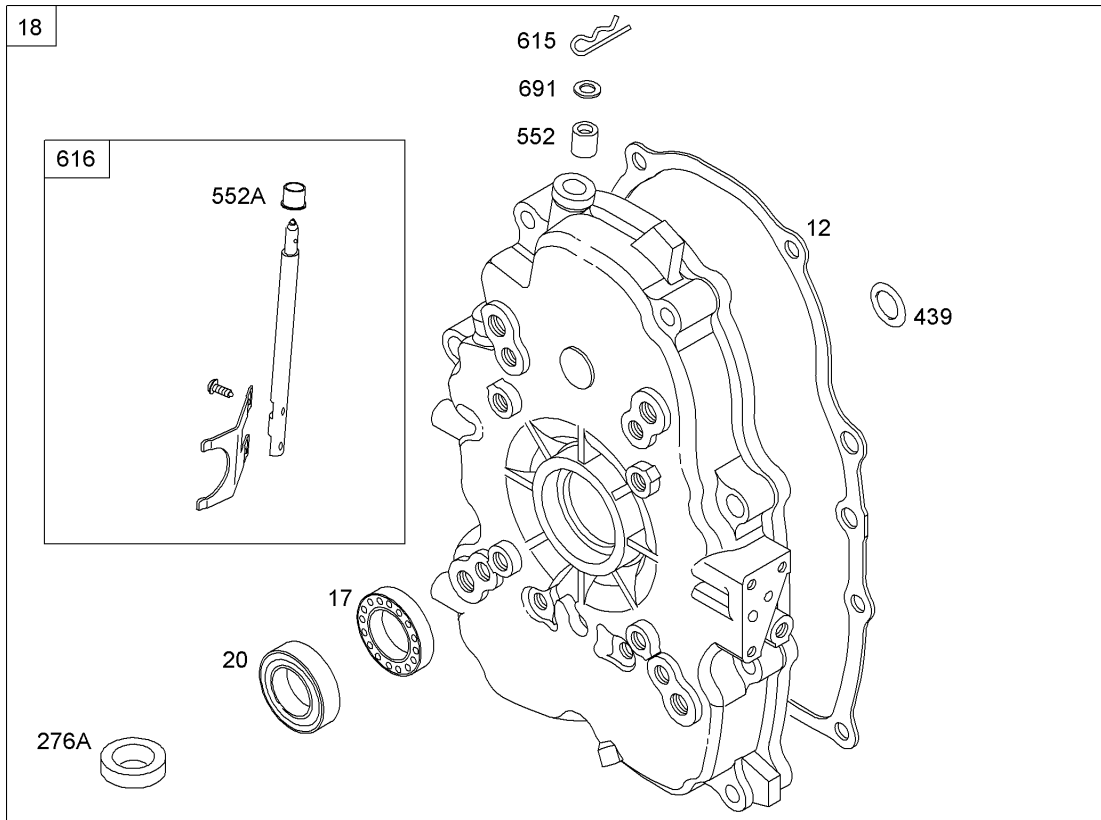



Assemblies include all parts shown in frames

## Crankcase Assembly Briggs and Stratton 303440-1326-E1

Ref	Part No.	Qty.	Description
18	691684	1	Gasket-Crankcase
17	690752	1	Bearing-Ball
18	808847	1	Cover-Crankcase
20	805049S	1	Seal-Oil (P-T-O Side)
22	807362	1	Screw (Crankcase Cover)
276A	690704	1	Washer-Sealing
439	692154	1	Seal-O Ring (Crankcase Cover)
552	690701	1	Bushing-Crank, Governor
552A	806686	1	Bushing-Crank, Governor
615	691550	1	Retainer-Shaft, Governor
616	806685	1	Crank-Governor
691	690680	1	Seal-Shaft, Governor

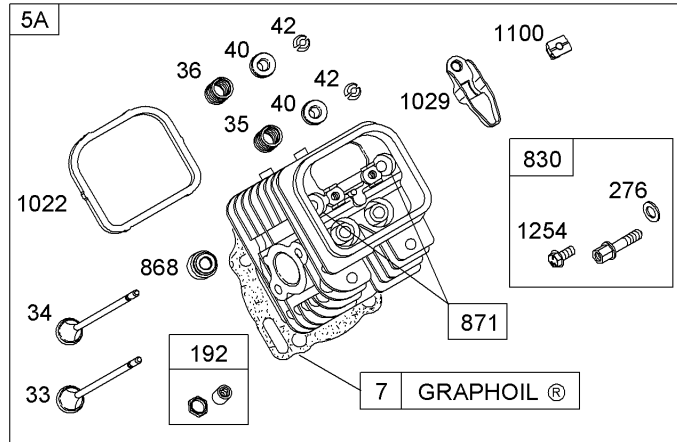
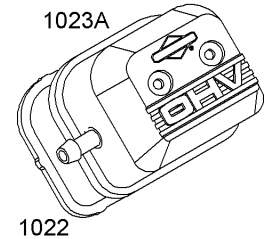
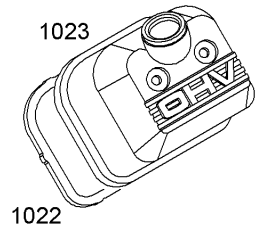
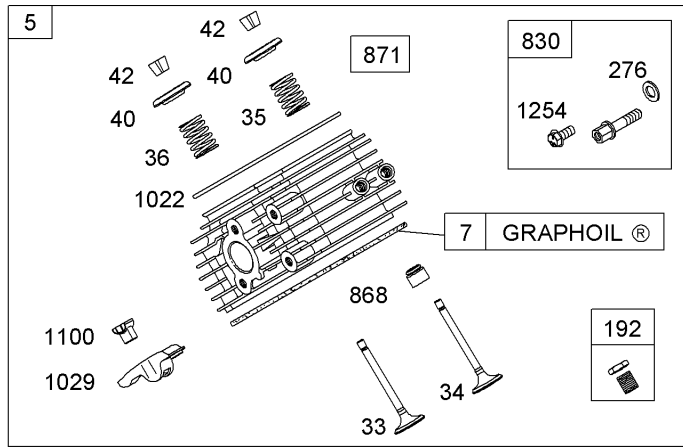
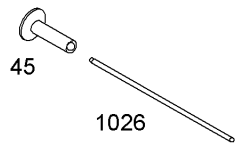

Assemblies include all parts shown in frames

## Cylinder Head Assembly Briggs and Stratton 303440-1326-E1

Ref	Part No.	Qty.	Description
5	809200	1	Head-Cylinder (Cylinder 1)
5A	809201	1	Head-Cylinder (Cylinder 2)
57	806085S	1	Gasket-Head, Cylinder
6			
13	692059	1	Screw (Cylinder Head)
21	809500	1	Cap-Fill, Oil
33	807681	1	Valve-Exhaust
34	807680	1	Valve-Intake
35	692084	1	Spring-Valve (Intake)
36	692084	1	Spring-Valve (Exhaust)
40	692058	1	Retainer-Valve
42	807683	1	Keeper-Valve
45	843379	1	Tappet-Valve
192	807623	1	Adjuster-Arm, Rocker
276	807085	1	Washer-Sealing
338	691312	1	Gasket-Dipstick
5830	809157	1	Stud-Arm, Rocker
6			
5868	691963	1	Seal-Valve
6			
5871	692057	1	Bushing-Guide, Valve
51022	806039S	1	Gasket-Cover, Rocker
6			
1023	690758	1	Cover-Valve
1023A	691558	1	Cover-Valve

Ref	Part No.	Qty.	Description
1026	691836	1	Rod-Push (Intake)
1026	691758	1	Rod-Push (Exhaust)
1029	807323	1	Arm-Rocker
1100	791959	1	Pivot-Arm, Rocker
1254	807084	1	Screw (Rocker Arm Stud)



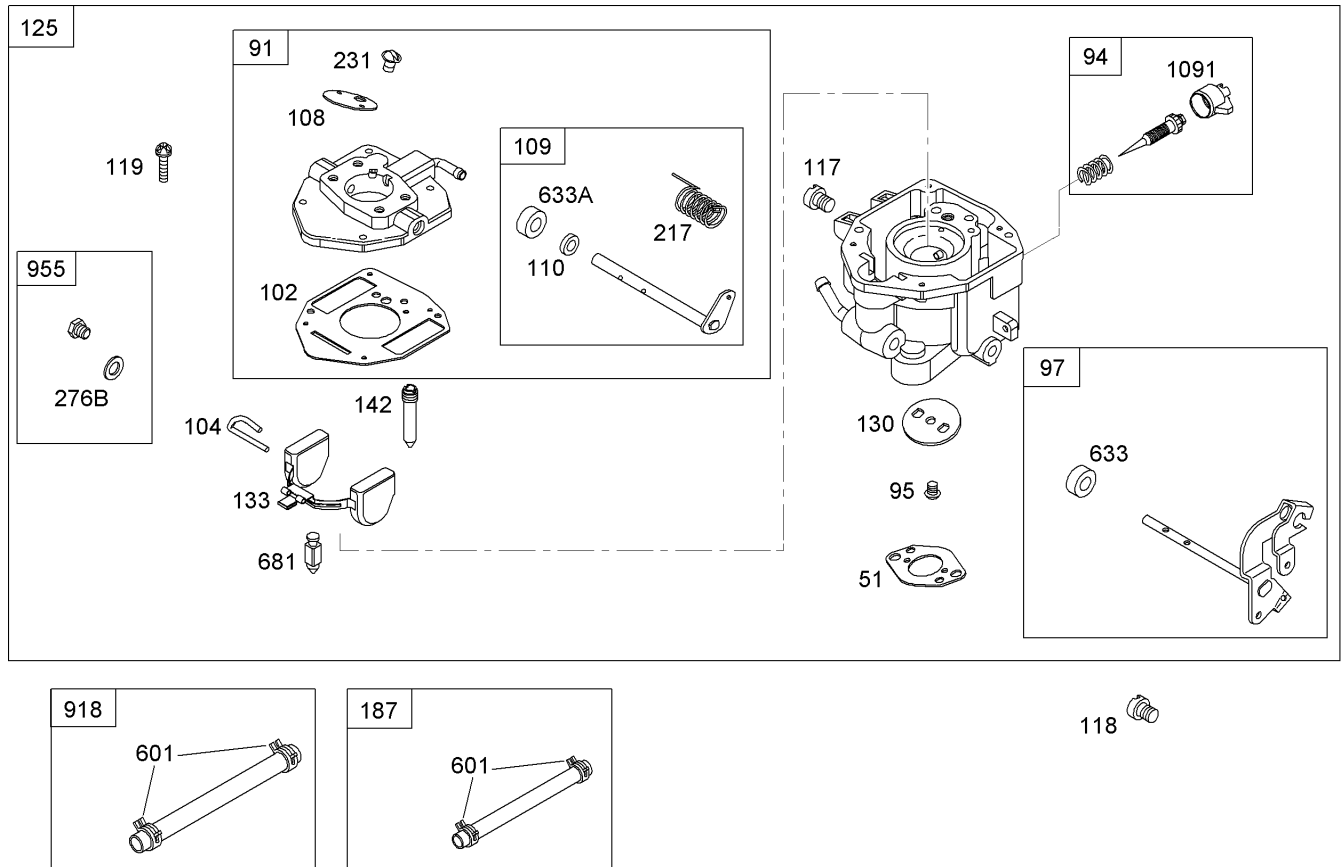

Assemblies include all parts shown in frames

## Carburetor Assembly Briggs and Stratton 303440-1326-E1

Ref	Part No.	Qty.	Description
④51	691694	1	Gasket-Intake
⑤			
⑨91	843532	1	Body-Carburetor, Upper
④94	842870	1	Idle Mixture Kit
⑨95	690718	1	Screw (Throttle Valve)
⑨97	841498	1	Shaft-Throttle
④102	692077	1	Gasket-Body, Carburetor
④104	690723	1	Pin-Hinge, Float
⑩108	690719	1	Valve-Choke
⑩109	808962	1	Shaft-Choke
⑩110	806861	1	Washer (Choke Shaft)
⑩117	842318	1	Jet-Main (STD)
⑩118	842836	1	Jet-Main (High Altitude)
⑩118	842837	1	Jet-Main (High Altitude)
⑩118	842839	1	Jet-Main (High Altitude)
⑩119	842761	1	Screw (Upper To Lower Body)
⑩125	843130	1	Carburetor
⑩130	690726	1	Valve-Throttle
⑩133	806961	1	Float-Carburetor
⑩142	842319	1	Nozzle-Carburetor
⑩187	791766	1	Line-Fuel (Cut To Required Length)
⑩217	806862	1	Spring-Return, Choke
⑩231	690718	1	Screw (Choke Valve)

Ref	Part No.	Qty.	Description
④276B	690724	1	Seal-O Ring (Carburetor Plug)
⑩601	691038	1	Clamp-Hose
④633	806131	1	Seal-Shaft, Choke Throttle
④633A	690722	1	Seal-Shaft, Choke Throttle
④681	808798	1	Valve-Needle, Float
⑨918	393815	1	Line-Vacuum
⑨955	808176	1	Plug-Carburetor
④1091	691516	1	Cap-Limiter

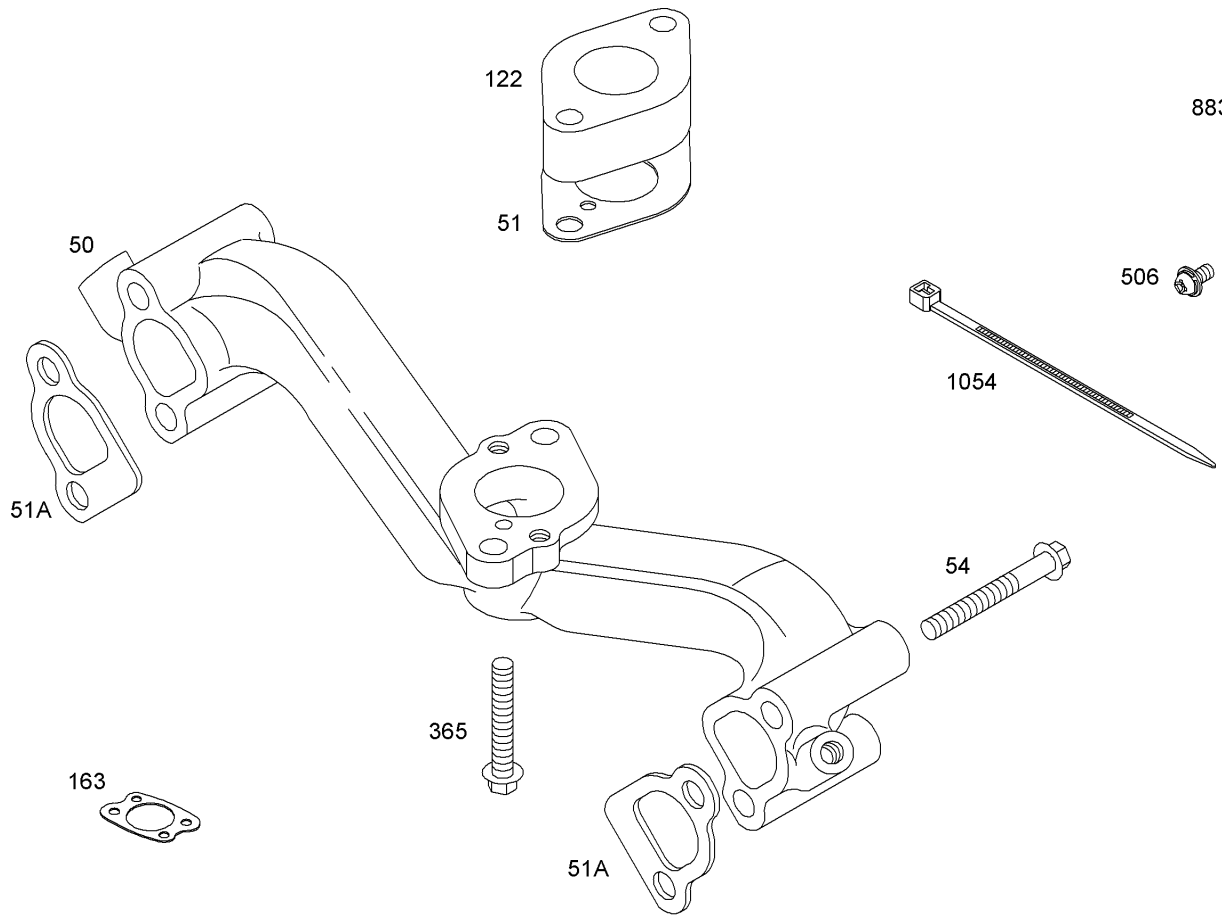

Assemblies include all parts shown in frames

## Intake Manifold Assembly Briggs and Stratton 303440-1326-E1

Ref	Part No.	Qty.	Description
50	690754	1	Manifold-Intake
51	691694	1	Gasket-Intake
51A	692035	1	Gasket-Intake
54	690676	1	Screw (Intake Manifold)
122	690691	1	Spacer-Carburetor
163	692081	1	Gasket-Cleaner, Air
365	690711	1	Screw (Carburetor)
506	690677	1	Screw (Carburetor Cover)
883	691613	1	Gasket-Exhaust
1054	280275	1	Tie-Cable

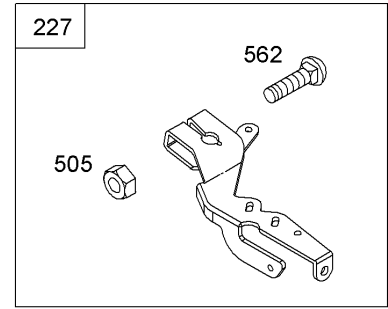
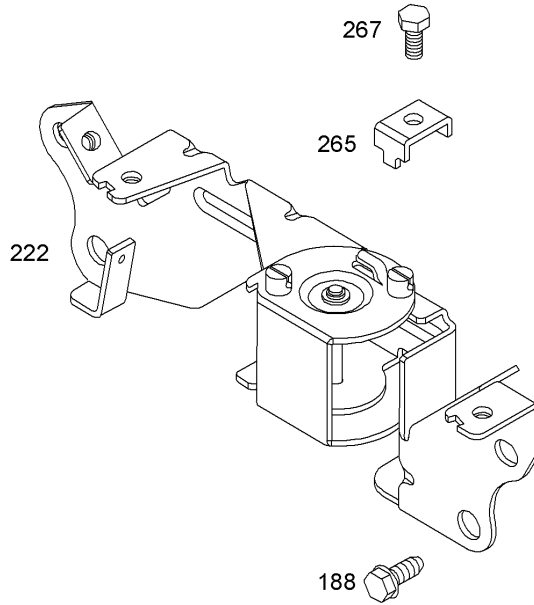
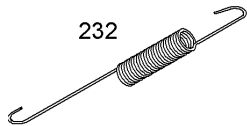
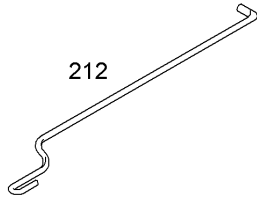
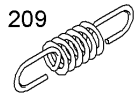

Assemblies include all parts shown in frames

## Governor Assembly Briggs and Stratton 303440-1326-E1

Ref	Part No.	Qty.	Description
●188	692056	1	Screw (Control Bracket)
●209	691507	1	Spring-Governor
●212	690712	1	Link-Throttle
●222	691570	1	Bracket-Control
●227	690236	1	Lever-Control, Governor
●232	692073	1	Spring-Link, Governor
●265	691024	1	Clamp-Casing
●267	841552	1	Screw (Casing Clamp)
●505	690238	1	Nut (Governor Control Lever)
●562	690239	1	Bolt (Governor Control Lever)

--	--	--	--





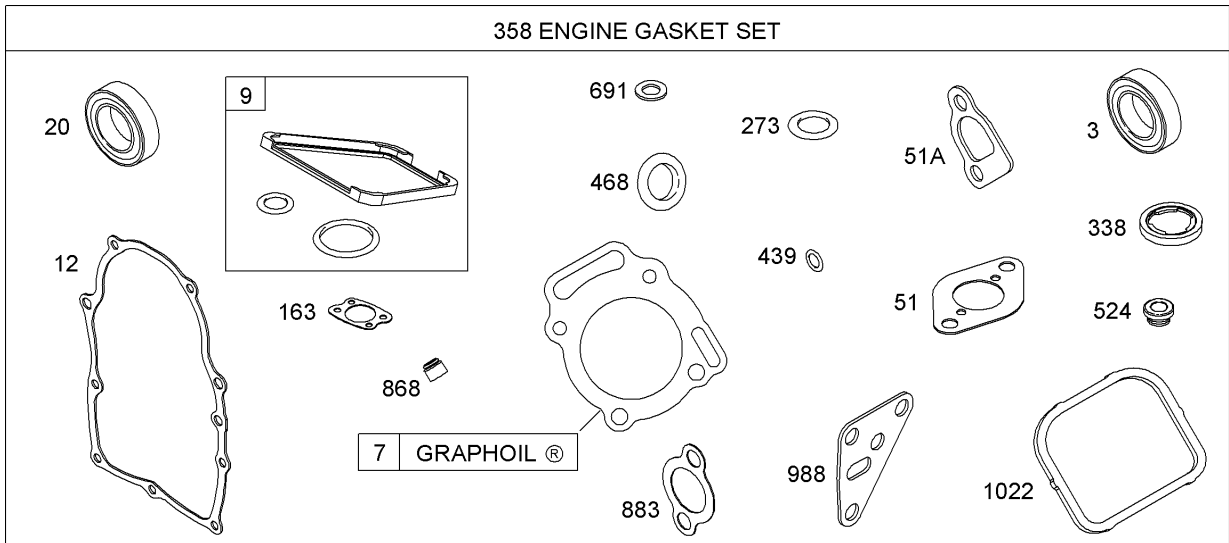

Assemblies include all parts shown in frames

## Engine Gasket Set Briggs and Stratton 303440-1326-E1

Ref	Part No.	Qty.	Description
353	805101S	1	Seal-Oil (Magneto Side)
347	806085S	1	Gasket-Head, Cylinder
359	809094	1	Gasket-Breather
3512	691684	1	Gasket-Crankcase
3520	805049S	1	Seal-Oil (P-T-O Side)
3451	691694	1	Gasket-Intake
3451A	692035	1	Gasket-Intake
35163	692081	1	Gasket-Cleaner, Air
35273	690681	1	Seal-O Ring (Oil Pump)
34338	691312	1	Gasket-Dipstick
358	808390	1	Engine Gasket Set
35439	692154	1	Seal-O Ring (Crankcase Cover)
35468	690690	1	Seal-O Ring (Oil Pump Screen)
35524	693172	1	Seal-Tube, Dipstick
35691	690680	1	Seal-Shaft, Governor
34868	691963	1	Seal-Valve
34883	691613	1	Gasket-Exhaust
35988	692063	1	Gasket-Adapter, Oil Filter
341022	806039S	1	Gasket-Cover, Rocker

--	--	--	--

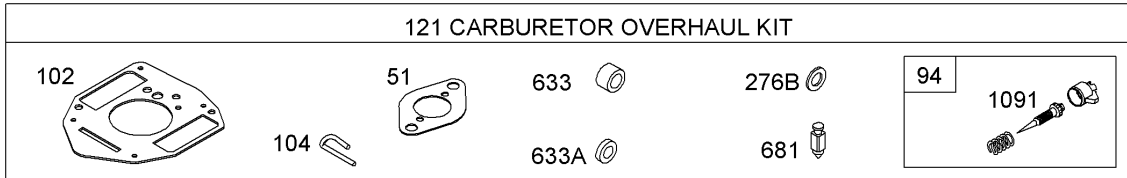
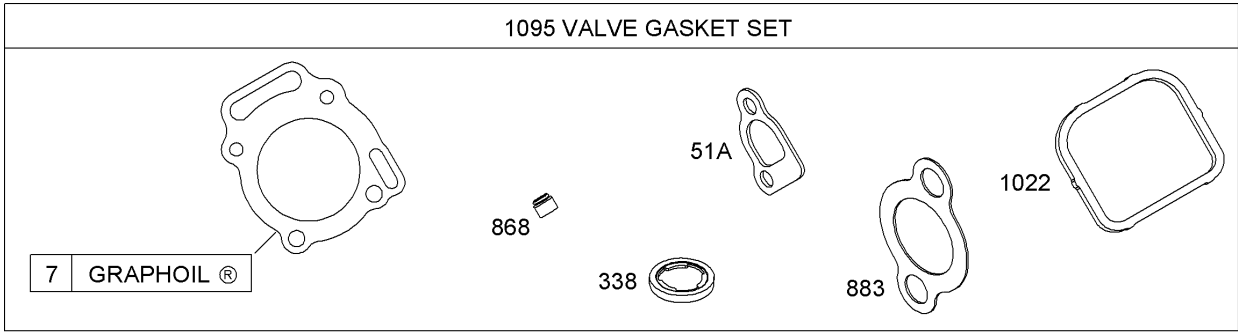

Assemblies include all parts shown in frames

## Carburetor Overhaul Kit Briggs and Stratton 303440-1326-E1

Ref	Part No.	Qty.	Description
3 4 7 6	806085S	1	Gasket-Head, Cylinder
3 4 51 5	691694	1	Gasket-Intake
3 4 51A 6	692035	1	Gasket-Intake
3 4 94	842870	1	Idle Mixture Kit
3 4 102	692077	1	Gasket-Body, Carburetor
3 4 104	690723	1	Pin-Hinge, Float
3 121	842877	1	Carburetor Overhaul Kit
3 4 276B	690724	1	Washer-Sealing
3 4 338 6	691312	1	Gasket-Dipstick
3 4 633	806131	1	Seal-Shaft, Choke Throttle
3 4 633A	690722	1	Seal-Shaft, Choke Throttle
3 4 681	808798	1	Valve-Needle, Float
3 4 868 6	691963	1	Seal-Valve
3 4 883 6	691613	1	Gasket-Exhaust
3 4 1022 6	806039S	1	Gasket-Cover, Rocker
3 4 1091	691516	1	Cap-Limiter
3 1095	808392	1	Valve Gasket Set

--	--	--	--

# Attachments and Accessories

## For 07277TC - Workman 2110 Utility Vehicle

Product Name	Model/Part
Stand Alone Windshield Kit	07221
Electric Bed Lift Kit	07262
Rear Lift Kit	07274
Roll-Over Protection System	07276
Receiver Hitch Kit	07278
Heavy-Duty Bumper Kit	07282
Stake Side Kit	07290
Cab	07291
Snow Plow-Mid Duty	07292
Folding Windshield Kit	07293
Windshield Kit	07294
Heavy-Duty Brushguard and Bumper Kit	07296
Canopy Kit	07297
Portable Refreshment Center	07298
Clutch Guard ASM	104-6408-03
Horn Kit	104-6663
Brake and Taillights (Rear lights, side reflectors)	104-6697
Signal Lights (Front marker lights / turn signal control)	104-6953
Key Start Kit	107-0330
Vinyl Enclosure	79979
Electric Harness Kit	99-7924

