

TORO[®]MODEL NO. 30753-390001-
590001 & UP**PARTS
CATALOG****52" PROLINE
Side Discharge Cutting Unit**

T-0066

DECK & SPINDLE ASSEMBLY

Ref. No.	Part No.	Description	No. Used	Ref. No.	Part No.	Description	No. Used
1	3217-6	Nut - Lock	4	17	40-0340	Shaft - Rear Roller	2
2	3253-4	Washer - Lock	4	18	56-5560	Belt - Deck	1
3	3296-5	Nut - Lock	2	19	27-7680	Ring - Deck Support	3
4	13-3949	Deflector - Grass (Incl. Ref.# 39)	1	20	27-0871	Spindle Assembly	3
5	29-5590	Bracket - Deflector Pivot	2	21	3253-27	Washer - Lock	3
6	3296-5	Nut - Lock	1	22	44-2200	Screw - Blade	3
7	65-5950	Bushing	1	23	72-9361	Cup - Anti-Scalp	3
8	65-5940	Pulley - Idler	1	24	27-0990	Blade	3
9	7-0081	Washer - Special	1	25	32128-21	Nut - Flange Lock	18
10	3211-8	Screw - Hex. Hd.	1	27	14-2359	Housing (Incl. Ref. #1-2, 29-31, & 40 pg. 2)	1
11	19-1470	Bolt - Shoulder	1	28	3230-22	Bolt - Carriage	1
12	56-5520	Lever - Deck	1	29	57-0690	Pin - Special	1
13	3296-29	Nut - Lock	3	30	40-6400	Shaft - Roller	1
14	3272-11	Pin - Cotter	3	31	29-4820	Roller	2
15	3231-22	Screw - Carriage	18	32	56-5540	Anchor - Deck Spring	1
16	36-1740	Roller - Deck	2				

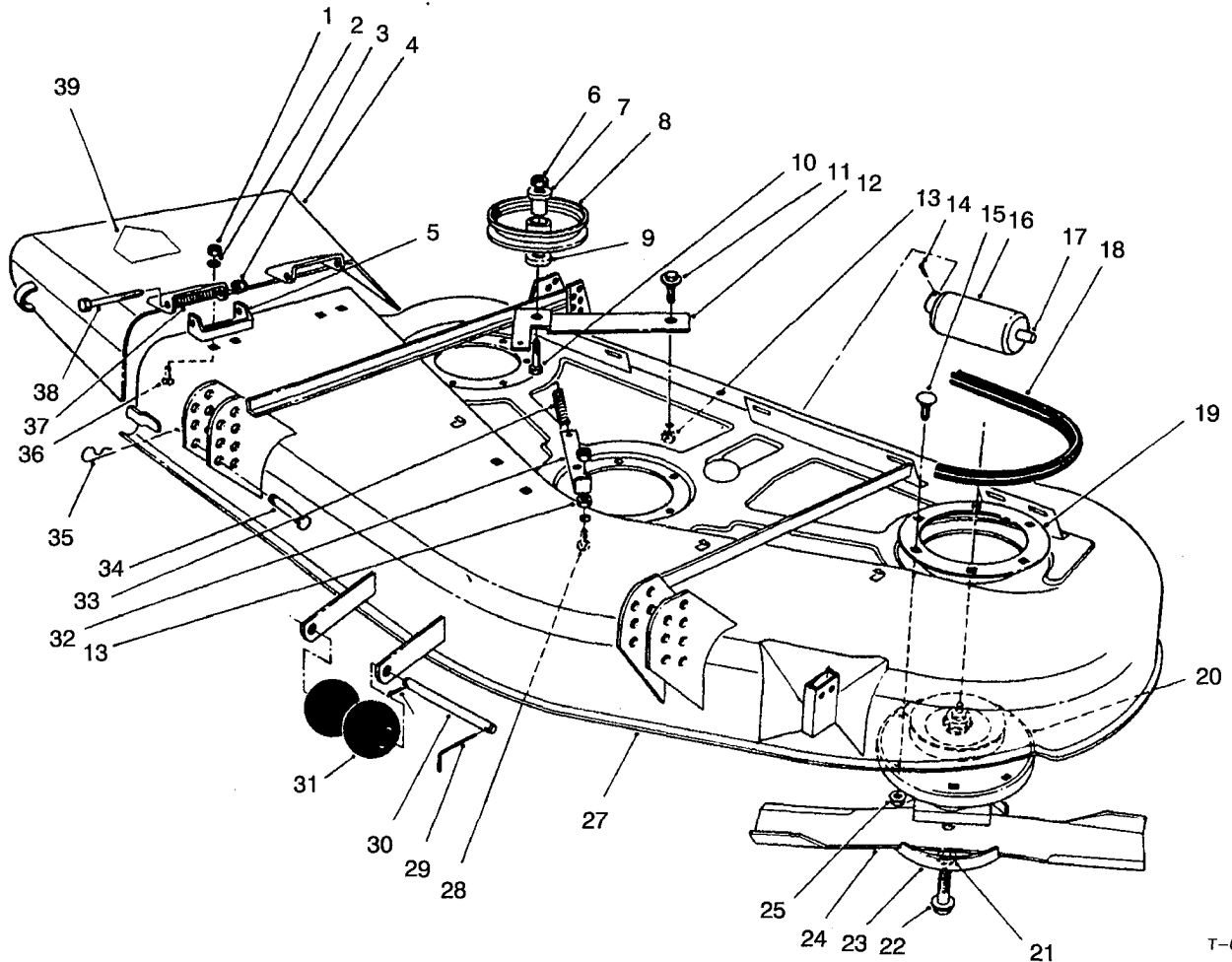
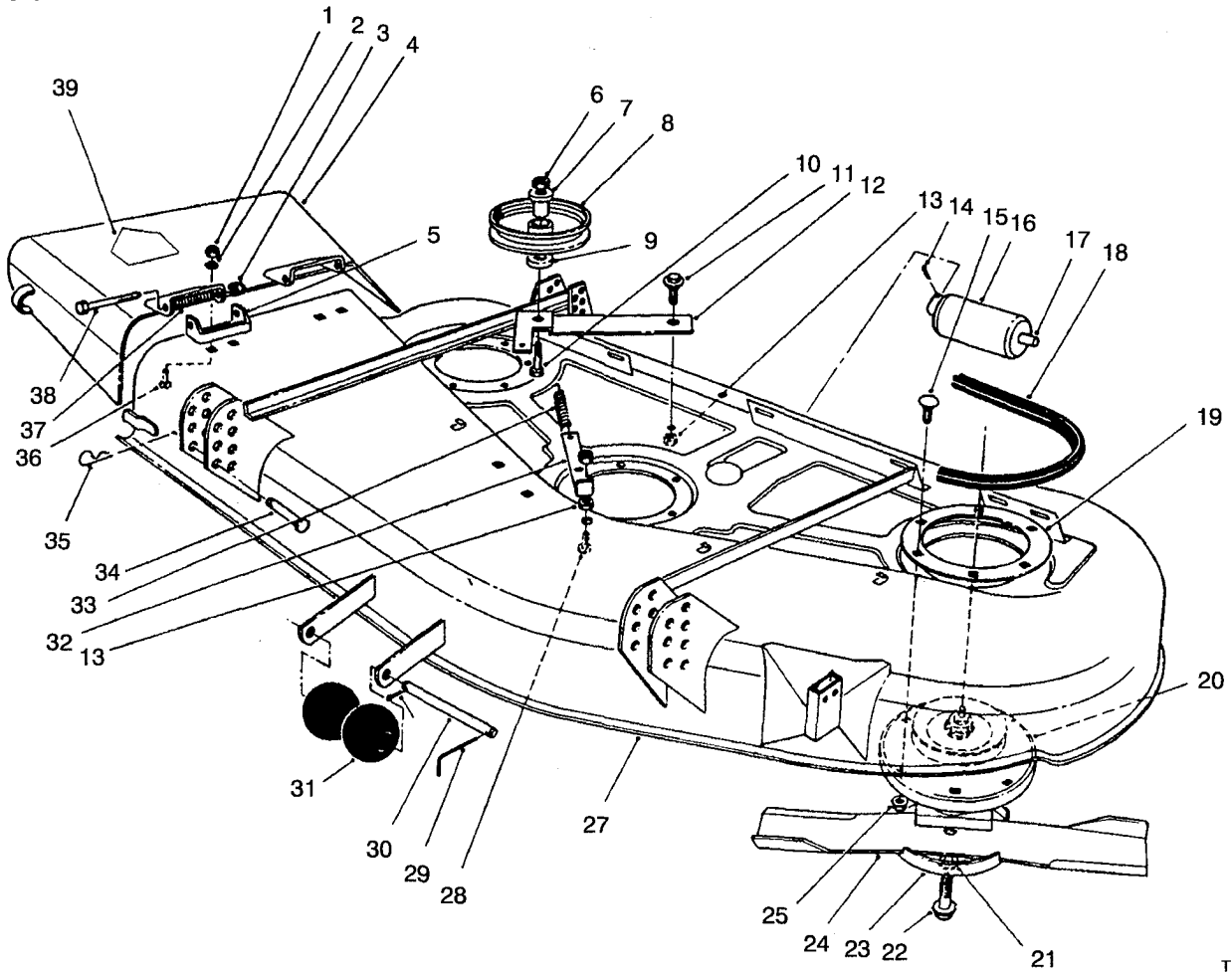

T-0066

DECK & SPINDLE ASSEMBLY (Continued)

Ref. No.	Part No.	Description	No. Used
33	54-1160	Spring - Extension	1
34	283-55	Pin - Clevis	4
35	3290-355	Pin - Cotter	4
36	3230-18	Bolt - Carriage	4

Ref. No.	Part No.	Description	No. Used
37	40-6230	Spring	2
38	3211-15	Screw - Hex. Hd.	2
39	54-9220	Decal - Danger	1

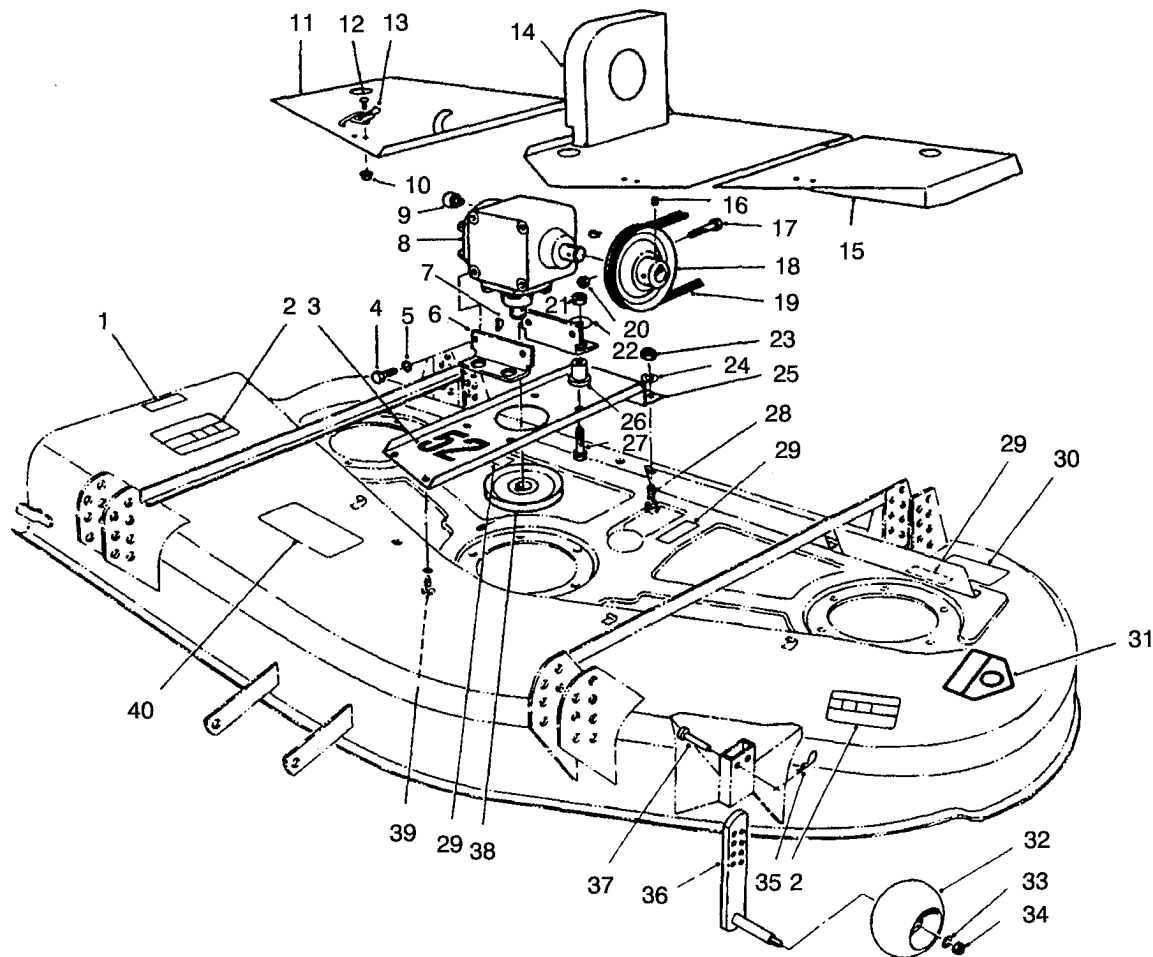

T-0088

DECK, COVERS, GEAR BOX, GAGE & WHEEL

Ref. No.	Part No.	Description	No. Used
1	66-6380	Decal - Deflector Missing	1
2	66-1340	Decal - Danger	2
3	51-3960	Decal - 52"	1
4	323-4	Screw	4
5	3253-21	Washer - Lock	4
6	63-9810	Bracket - Mounting	2
7	3257-14	Key - Woodruff	2
8	53-4600	Gear Box	1
9	302-34	Vent	1
10	32128-17	Nut - Flange Lock	6
11	56-5610	Cover - Deck L.H.	1
12	3290-321	Screw	6
13	249-21	Latch	3
14	56-5590	Cover - Center	1
15	56-5580	Cover - Deck L.H.	1
16	3241-1	Screw - Set	2
17	321-18	Screw	2
18	62-5940	Pulley - Gear box	1
19	56-5570	Belt - Deck Drive	1
20	3296-16	Nut - Lock	2

Ref. No.	Part No.	Description	No. Used
21	32153-2	Nut - Lock	4
22	63-8410	Washer	4
23	3296-29	Nut - Lock	4
24	3256-3	Washer	4
25	63-9820	Base - Gear Box Mount	1
26	63-9750	I.S.O. Mount - Gear box	4
27	323-8	Screw	4
28	322-4	Screw	2
29	67-5360	Decal - Shield Missing	3
30	68-8340	Decal - Blade Torque	1
31	43-8480	Decal - Danger	1
32	68-2730	Gage - Wheel	1
33	3256-24	Washer - Flat	1
34	3296-39	Nut - Lock	1
35	3290-467	Pin - Cotter	1
36	68-2350	Plate - Gage Wheel	1
37	283-2	Pin Cotter	1
38	65-5410	Pulley	1
39	3230-10	Bolt - Carriage	2
40	68-7260	Decal - Rear Weight	1

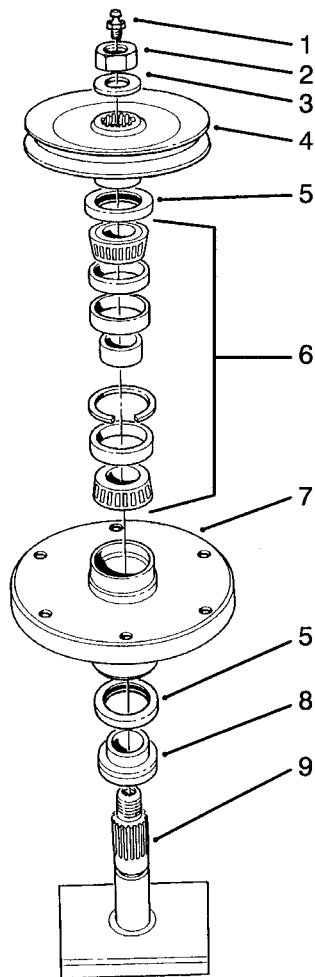

T-0111

DRIVE SPINDLE ASSEMBLY NO. 27-0871

Ref. No.	Part No.	Description	No. Used	Ref. No.	Part No.	Description	No. Used
1	302-2	Fitting - Grease	1	6	46-8530	Bearing Assembly	1
2	32146-20	Nut	1	7	61-4160	Housing - Spindle	1
3	7-4150	Washer	1	8	27-0950	Spacer	1
4	56-2510	Pulley & Hub Assembly	1	9	27-0920	Shaft - Spindle	1
5	253-139	Seal - Wave	2				

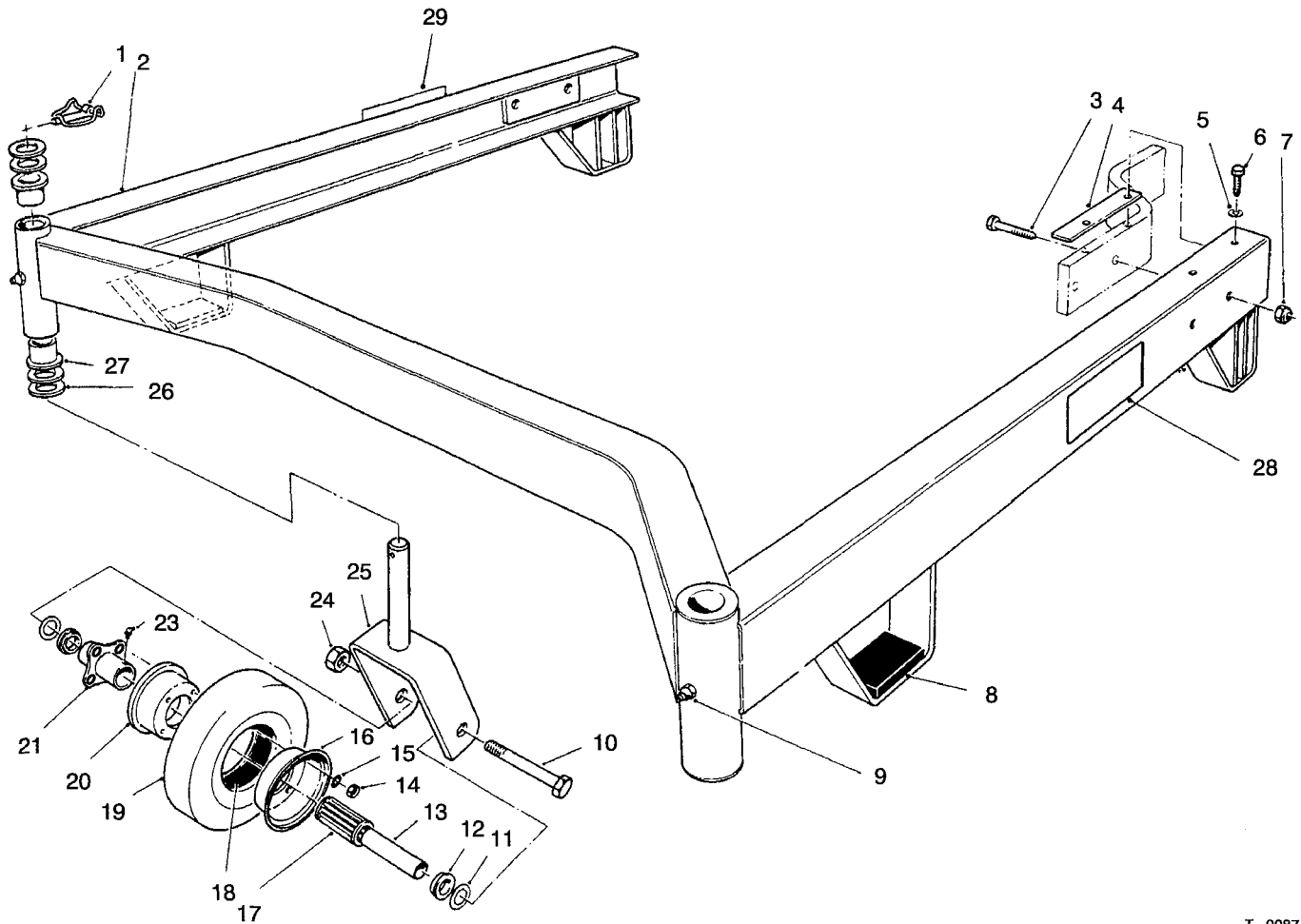

T-0087

CARRIER FRAME

Ref. No.	Part No.	Description	No. Used
1	3290-384	Pin - Lynch	2
2	55-4630	Suspension Assembly - 52" (Incl. Ref. #9, & 27)	1
3	323-9	Screw	4
4	62-6980	Shim - Carrier	2
5	3256-24	Washer - flat	4
6	3234-25	Screw	4
7	32153-2	Nut	4
8	74-0340	Cushion - Rubber	2
9	302-5	Fitting - Grease	2
10	325-19	Screw	2
11	3256-6	Spacer - Wheel	4
12	62-5580	Bushing	4
13	68-8980	Bushing - Spanner	2
14	3219-2	Nut	8
15	3253-4	Washer	8

Ref. No.	Part No.	Description	No. Used
16	68-8930	Wheel Half - Male	2
17	62-5570	Bearing - Roller	2
18	68-8950	Tube w/Valve	2
19	68-8960	Tire	2
20	68-8920	Wheel Half - Female	2
21	68-8940	Hub - Centered	2
23	302-11	Fitting - Grease	2
24	32153-5	Nut	2
25	68-8900	Fork - Caster	2
26	3-6781	Washer - Thrust	8
27	28-9290	Bushing	4
28	74-0940	Decal - Height of Cut L.H.	1
29	68-8360	Decal - Height of Cut R.H.	1
*	13-3869	Caster Wheel Assembly (Incl. Ref. #11-21)	2

GEARBOX ASSEMBLY NO. 1100-010

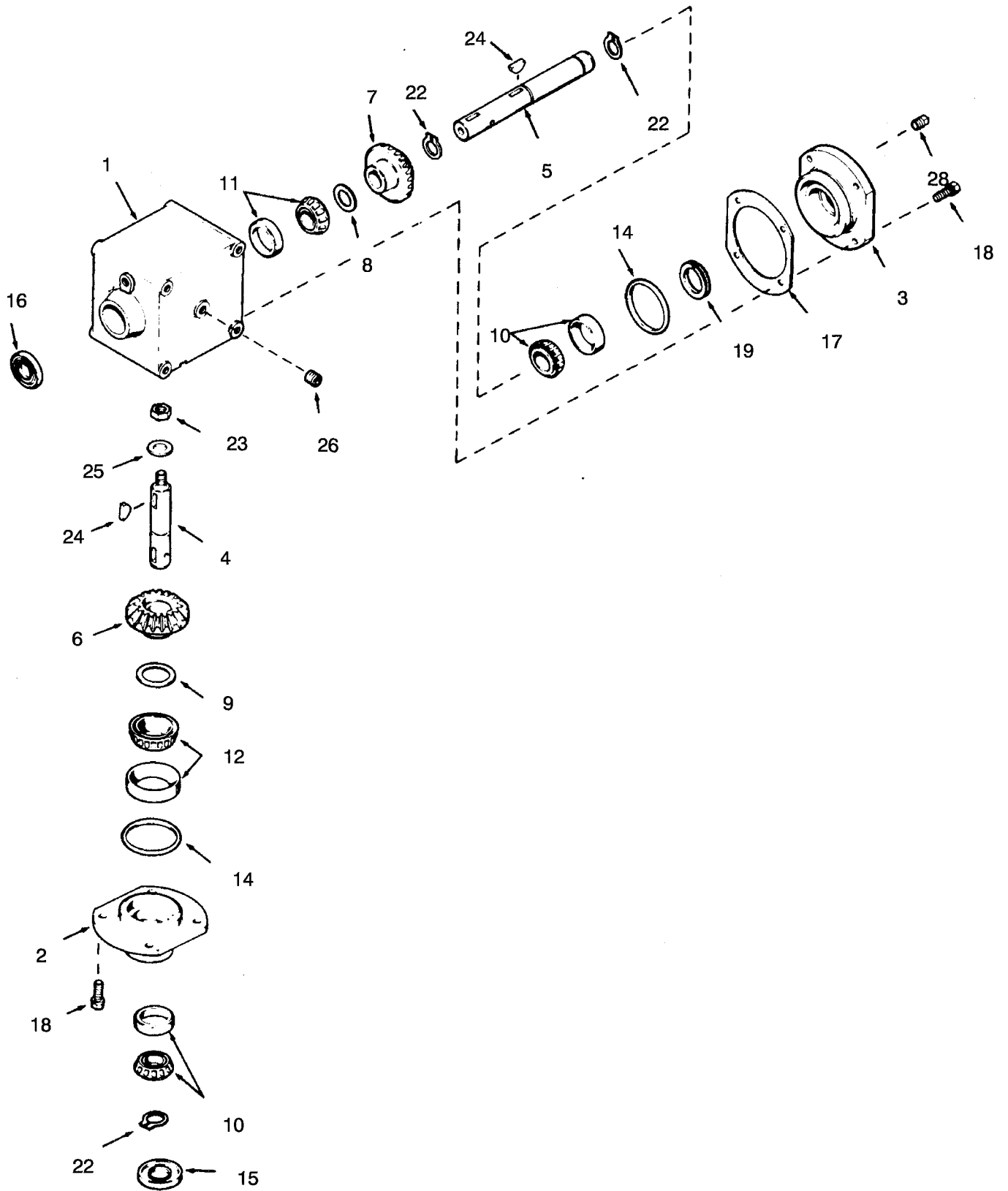

GEARBOX ASSEMBLY NO. 1100-010

Ref. No.	Part No.	Description	No. Used	Ref. No.	Part No.	Description	No. Used
1	770076	Housing	1	12	780134	Bearing & Cup Assembly	
2	786104A	Cap - Retainer	1			This is a factory sized assembly and may or may not include shim Ref. #9.	
3	786106	Cap - Retainer	1			If shim Ref. #9 is supplied, it must be used in this location. All old shims must be discarded.)	1
4	776224	Shaft - Input	1	14	788063	"O"Ring	1
5	776223	Shaft - Output	1	15	788064	Seal - Oil	1
6	778167	Gear - Bevel 25T	1	16	788065	Seal - Oil	1
7	778171	Gear - Bevel 26T	1	17	780136	Shim - Cap Retainer	1
8	780131	Shim (1.5" OD x 1.016" ID x .002")	A/R	18	792037	Screw-Hex. Hd.	1
9	780138	Shim (2" OD x 1.531" ID x .002")	A/R	19	780137	Ring - Load	1
10	780132	Bearing & Cup Assembly (This assembly may have a shim included. The shim is not required at this location)	1	22	792113	Ring - Retaining	1
11	780132	Bearing & Cup Assembly This is a factory sized assembly and may or may not include shim Ref. #8. If shim Ref. #8 is supplied, it must be used in this location. All old shims must be discarded.)	1	23	792110	Nut - Jam	1
				24	792114	Key - Woodruff	1
				25	792115	Washer - Flat	1
				26	792116	Plug - Pipe	1
				28	28534	Plug - Square Hd.	1

