



## PT21 Lawn Mower

Model No. 22164 - 280000001 and up.

### Parts Catalog

---

#### **Ordering Replacement Parts**

To order replacement parts, please supply the part number, the quantity, and the description of each part desired.

#### **Understanding Reference Numbers**

Each identified part in an illustration has a reference number. The reference number for a part also appears in the parts list, along with other information about the part.

This catalog uses two special reference number formats, one to indicate parts in a service assembly and another to indicate the quantity of a given part in an illustration.

#### **Service Assembly Reference Numbers**

Parts in service assemblies have reference numbers in the form a:b. The a represents the reference number of the entire service assembly and the b represents a sequential number unique to each part within the service assembly.

For example, a wheel assembly might be identified by reference number 6, the tire by 6:1, the valve by 6:2, and the wheel by 6:3. When you order the assembly identified by reference number 6, you receive all parts identified by reference numbers 6:1, 6:2, and 6:3. However, you may also order any part individually. Reference numbers of this type appear in illustrations and in part lists.

#### **Reference Numbers Indicating Quantity**

In an illustration, if a reference number indicates more than one part, the reference number has the form nX y. The n represents the quantity of the part, the X is the multiplication symbol, and the y represents the reference number.

For example, in an illustration, the reference number 2X 37 means that two of the parts identified by reference number 37 are indicated.

# Contents

Description	Page	Description	Page
Housing Assembly	..... 3	Cooling Equipment Assembly Kawasaki FJ180V-AS28	..... 16
Housing Assembly No. 108-4750	..... 4	Electric Equipment Assembly Kawasaki FJ180V-AS28	..... 17
Height-of-Cut Assembly	..... 5	Control Equipment Assembly Kawasaki FJ180V-AS28	..... 18
Wheel and Tire Assembly No. 100-2870	..... 6	Carburetor Assembly Kawasaki FJ180V-AS28	..... 19
Transmission Assembly	..... 7	Air Filter and Muffler Assembly Kawasaki FJ180V-AS28	..... 20
Rear Wheel Assembly No. 100-2860	..... 8	Fuel Tank and Fuel Valve Assembly Kawasaki FJ180V-AS28	..... 21
Gear Case Assembly No. 108-8140	..... 9	Starter Assembly Kawasaki FJ180V-AS28	..... 22
Engine Assembly	..... 10	Brake and Cover Assembly Kawasaki FJ180V-AS28	..... 23
Handle Assembly	..... 11	Decal Assembly Kawasaki FJ180V-AS28	..... 24
Cylinder and Crankcase Assembly Kawasaki FJ180V-AS28	..... 12	Attachments and Accessories List	..... 25
Piston and Crankshaft Assembly Kawasaki FJ180V-AS28	..... 13		
Valve and Camshaft Assembly Kawasaki FJ180V-AS28	..... 14		
Lubrication Equipment Assembly Kawasaki FJ180V-AS28	..... 15		

## Part Description Abbreviations

Part descriptions in this catalog may include the following abbreviations.

AR. .... as required	HYD. .... hydraulic
ASM. .... assembly	LH. .... left hand
BBC. .... blade brake clutch	NI. .... nylon insert
CARR. .... carriage	NPTF. .... national pipe thread fine
DEG. .... degrees	PFH. .... phillips flat head
EXT. .... external	PPH. .... phillips pan head
FH. .... flat head	PPHTF. .... phillips pan head thread forming
GA. .... gauge	PRH. .... phillips round head
HD. .... heavy-duty	PTH. .... phillips truss head
HF. .... hex flange	PTO. .... power-take-off
HH. .... hex head	RH. .... right hand
HHF. .... hex head flange	ROPS. .... roll-over protection system
HHFTF. .... hex head flange thread forming	SFH. .... slotted fillister head
HJ. .... hex jam	SHH. .... slotted hex head
HLH. .... hex lag head	SHWH. .... slotted hex washer head
HOC. .... height-of-cut	SPH. .... slotted pan head
HSBH. .... hex socket button head	SQH. .... square head
HSFH. .... hex socket flat head	SRH. .... slotted round head
HSH. .... hex socket head	STD. .... standard
HWH. .... hex washer head	TAP. .... self tapping
HWHTF. .... hex washer head thread forming	TTH. .... torx truss head

## Footnotes

❶ Not serviced separately

❷ Obtain from your local Kawasaki dealer

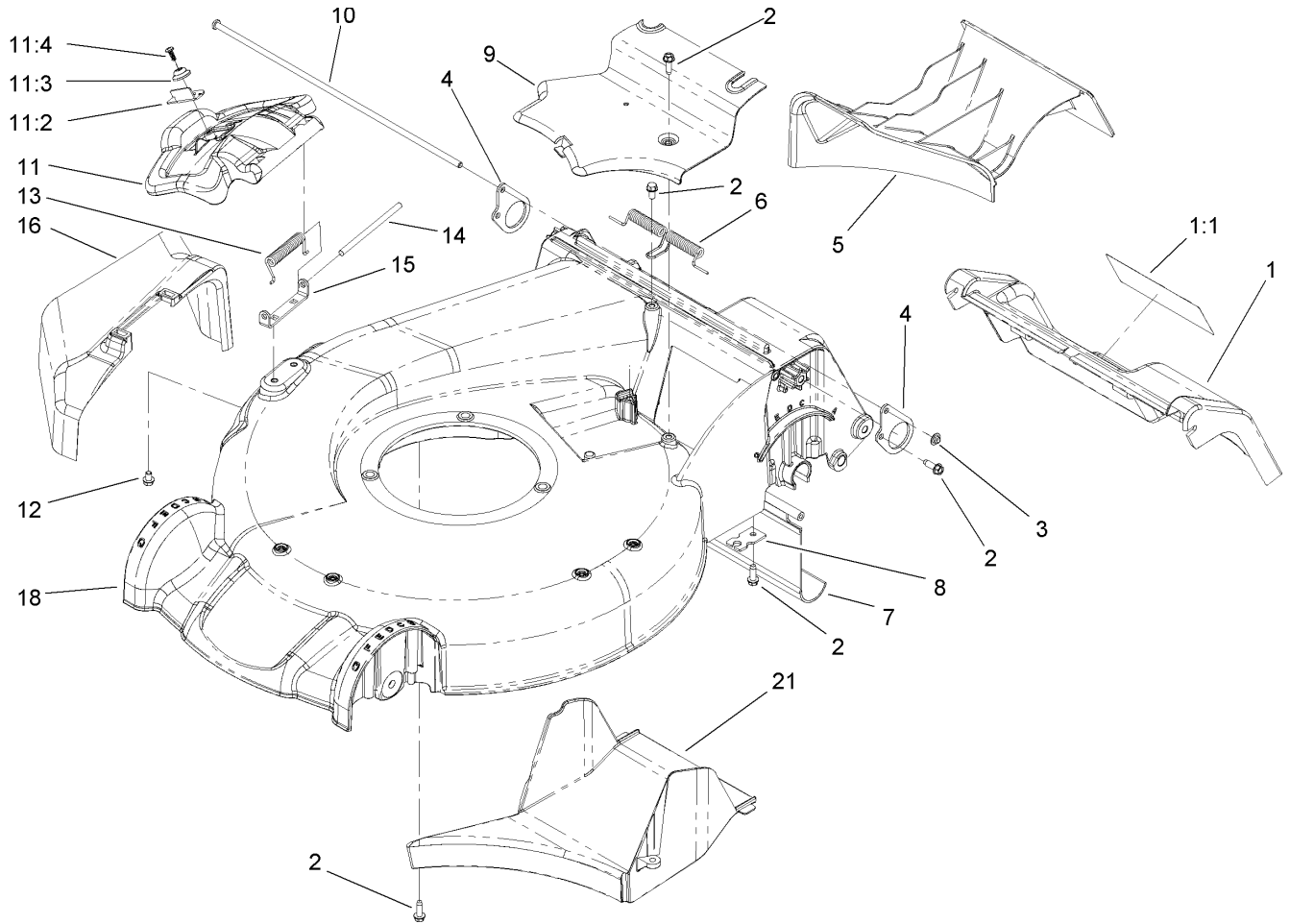

## Housing Assembly

Ref	Part No.	Qty.	Description
1	108-8169	1	Door-Service
1:1	105-1295	1	Decal-Warning
2	49-2040	7	Screw-HWHTF
3	3290-337	1	Nut-Speed
4	107-7493	2	Plate-Support, Door
5	107-7490	1	Mulch Plug ASM
6	105-3032	1	Spring-Door, Rear
7	114-1586	1	Shield-Trailing
8	107-7497	1	Bracket-Cable, Traction
9	107-7494	1	Cover-Belt
10	107-7499	1	Rod-Support, Door
11	107-3717	1	Discharge Door ASM
11:2	107-0795	1	Latch-Door
11:3	107-7456	1	Cap-Door
11:4	107-7461	1	Screw-Plastite
12	99-8445	2	Screw-HWH
13	99-5293	1	Spring-Torsion
14	99-5291	1	Rod-Cover
15	112-6416	1	Bracket-Cover
16	108-3753	1	Chute-Discharge, Side
18	108-4750	1	Housing ASM
21	107-7495	1	Tunnel-Discharge

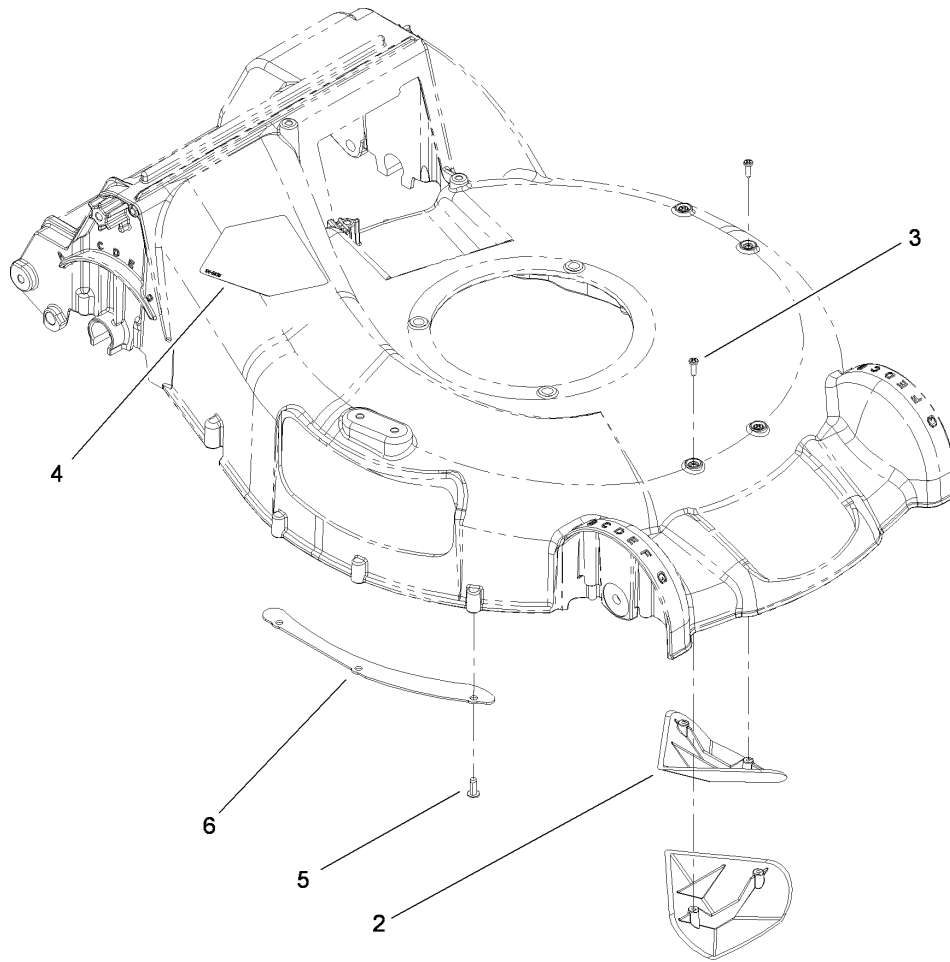
### Housing Assembly No. 108-4750

Ref	Part No.	Qty.	Description
2	108-3798	2	Kicker-Housing
3	32144-111	4	Screw-PPH
4	112-8760	1	Decal-Danger
5	63-8590	3	Screw
6	105-1316-03	1	Sheet-Lip

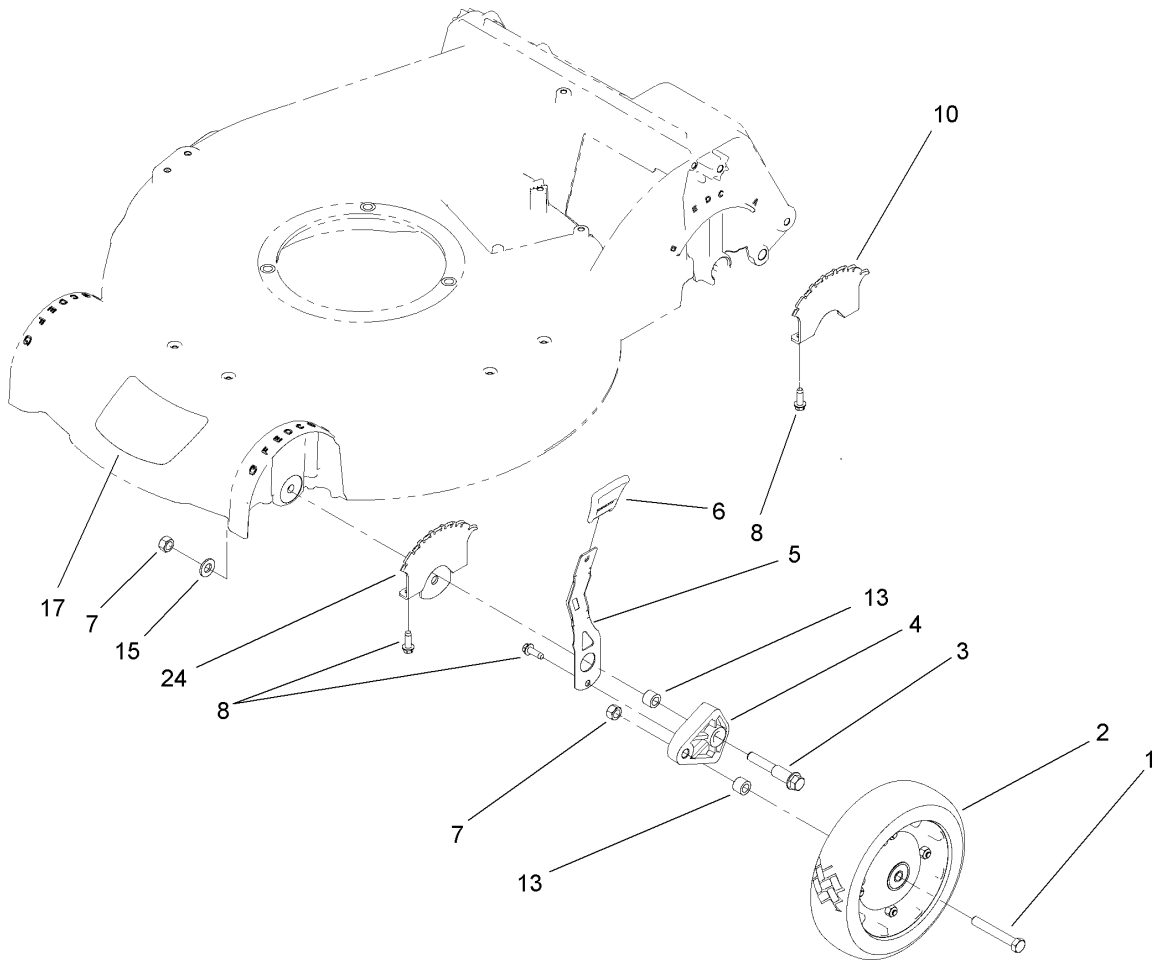

## Height-of-Cut Assembly

Ref	Part No.	Qty.	Description
1	323-12	2	Screw-HH
2	100-2870	2	Wheel And Tire ASM
3	114-3467	2	Screw-Shoulder
4	107-7492	2	Arm-Pivot
5	107-7491	2	Arm-Spring
6	110-0549	2	Knob-HOC
7	603773	4	Nut
8	49-2040	10	Screw-HWHTF
10	107-7478	2	Plate-HOC
13	52-2480	4	Spacer-Wheel
15	3256-24	2	Washer-Flat
17	110-4929	1	Decal-Housing, Front
24	110-4920-03	2	Bracket-Support

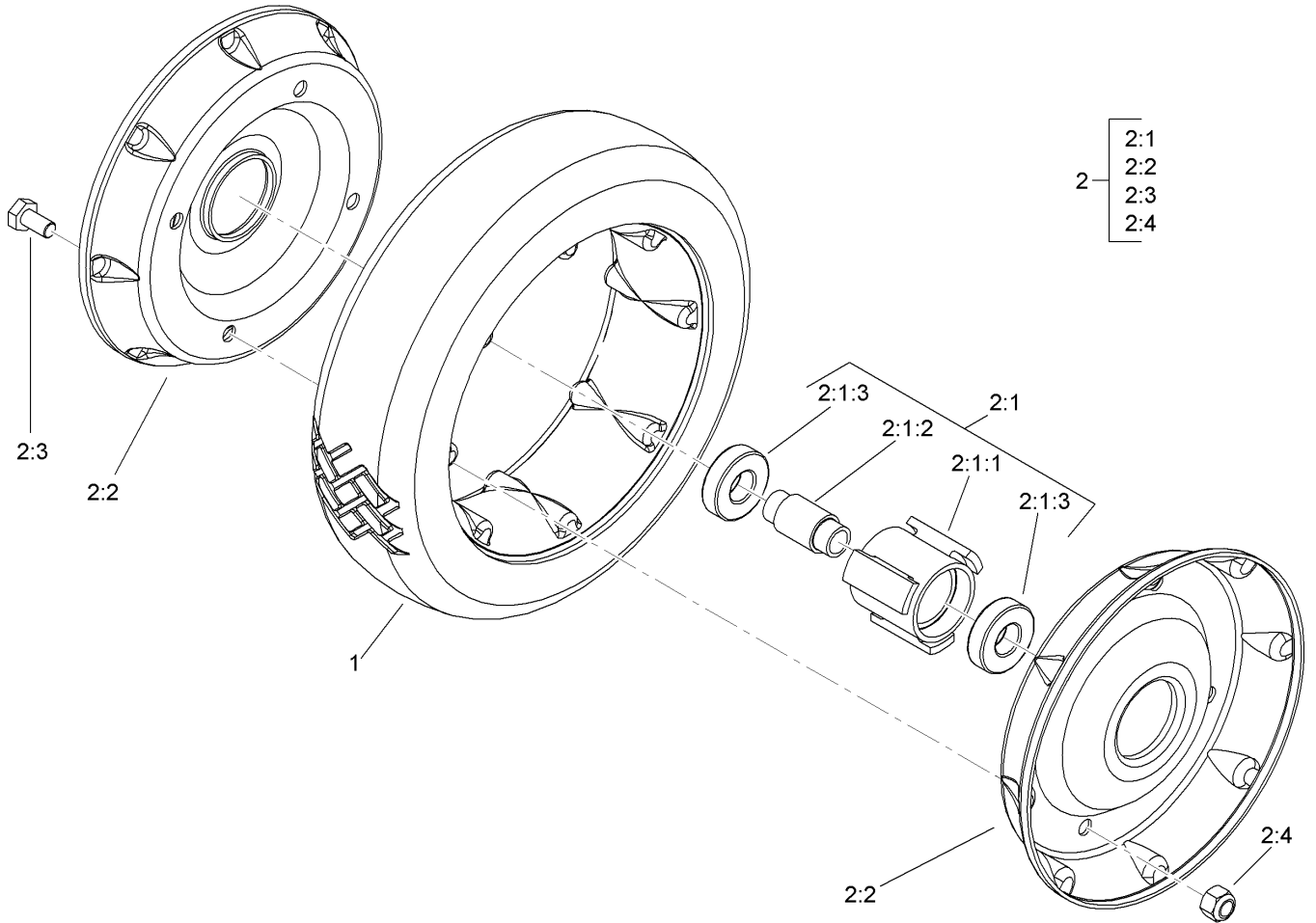
## Wheel and Tire Assembly No. 100-2870

Ref	Part No.	Qty.	Description
1	53-7740	1	Tire
2		1	Wheel ASM
2:1		1	Hub And Bearing ASM
2:1:1	52-2410	1	Hub-Bearing
2:1:2	52-2440	1	Spacer-Bearing
2:1:3	52-2450	2	Bearing-Wheel
2:2	53-7780-06	2	Plate-Wheel, Half
2:3	321-2	4	Screw-HH
2:4	3296-42	4	Nut-Lock, NI

## Transmission Assembly

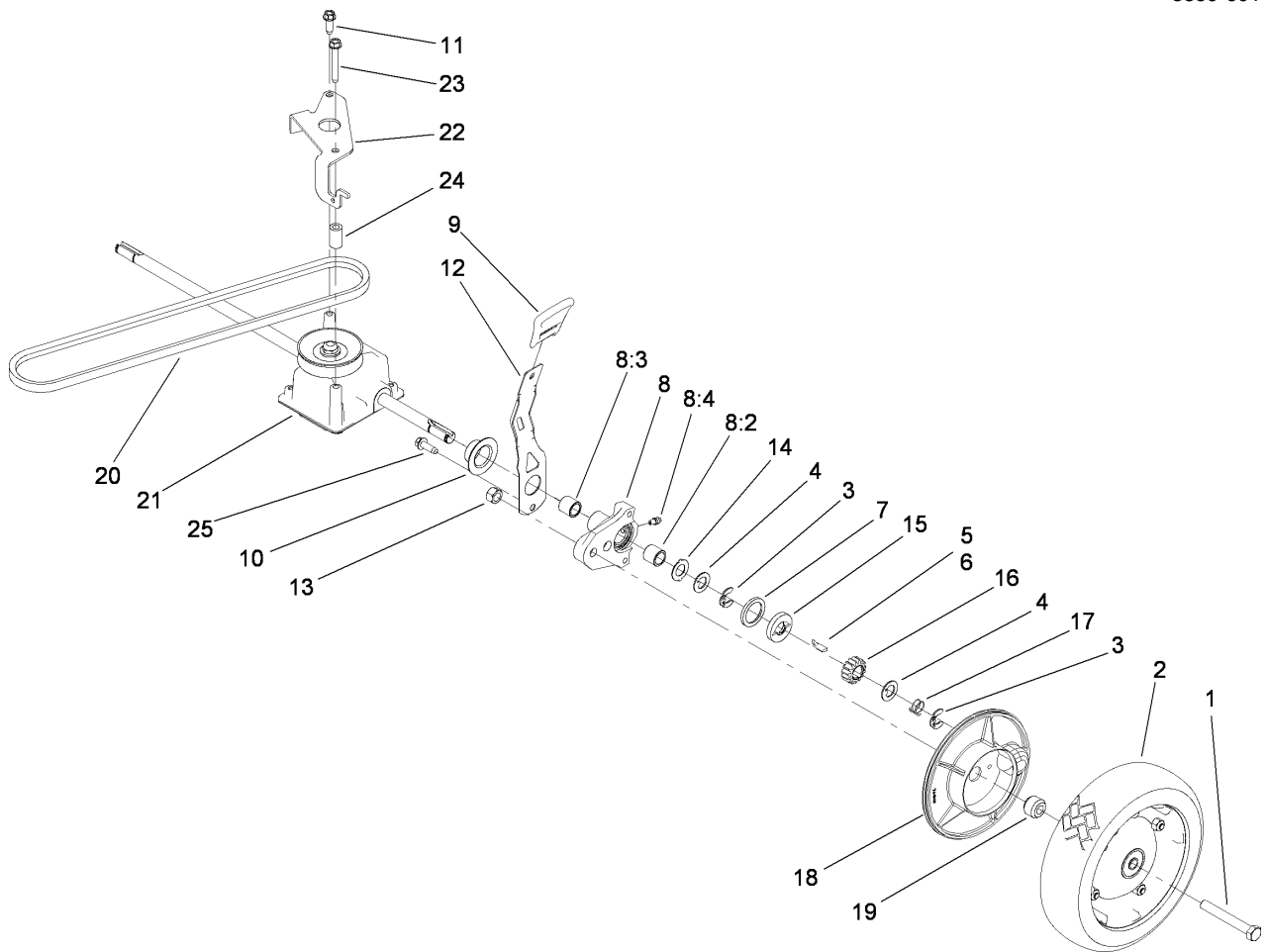
Ref	Part No.	Qty.	Description
1	323-13	2	Screw-HH
2	100-2860	2	Wheel And Tire ASM
3	65-2720	4	Ring-Clip, Locking
4	65-4740	4	Washer-Thrust, Keyed
5	66-6040	1	Key-Rocking, RH
6	66-6050	1	Key-Rocking, LH
7	65-4710	2	Ring-Friction
8	100-8774	2	Pivot Arm ASM
8:2	47-2900	1	Bushing
8:3	70-9760	1	Bushing
8:4	302-56	1	Fitting-Grease
9	110-0549	2	Knob-HOC
10	42-3520	2	Cap-End
11	49-2040	1	Screw-HWHTF
12	107-7491	2	Arm-Spring
13	603773	2	Nut
14	65-4730	2	Washer-Arm, Pivot
15	65-4760	2	Washer-Clutch
16	65-4750	2	Gear-Pinion
17	65-4720	2	Spring-Compression
18	74-1640	2	Cover-Wheel
19	74-1650	2	Spacer-Cover, Wheel
20	99-1597	1	V-Belt
21	108-8140	1	Gear Case ASM

Ref	Part No.	Qty.	Description
22	107-7483-03	1	Bracket-Gearbox
23	92-1616	1	Screw-HWHTF
24	614673	1	Bushing-Plate, Actuator
25	32144-85	2	Screw-HWH

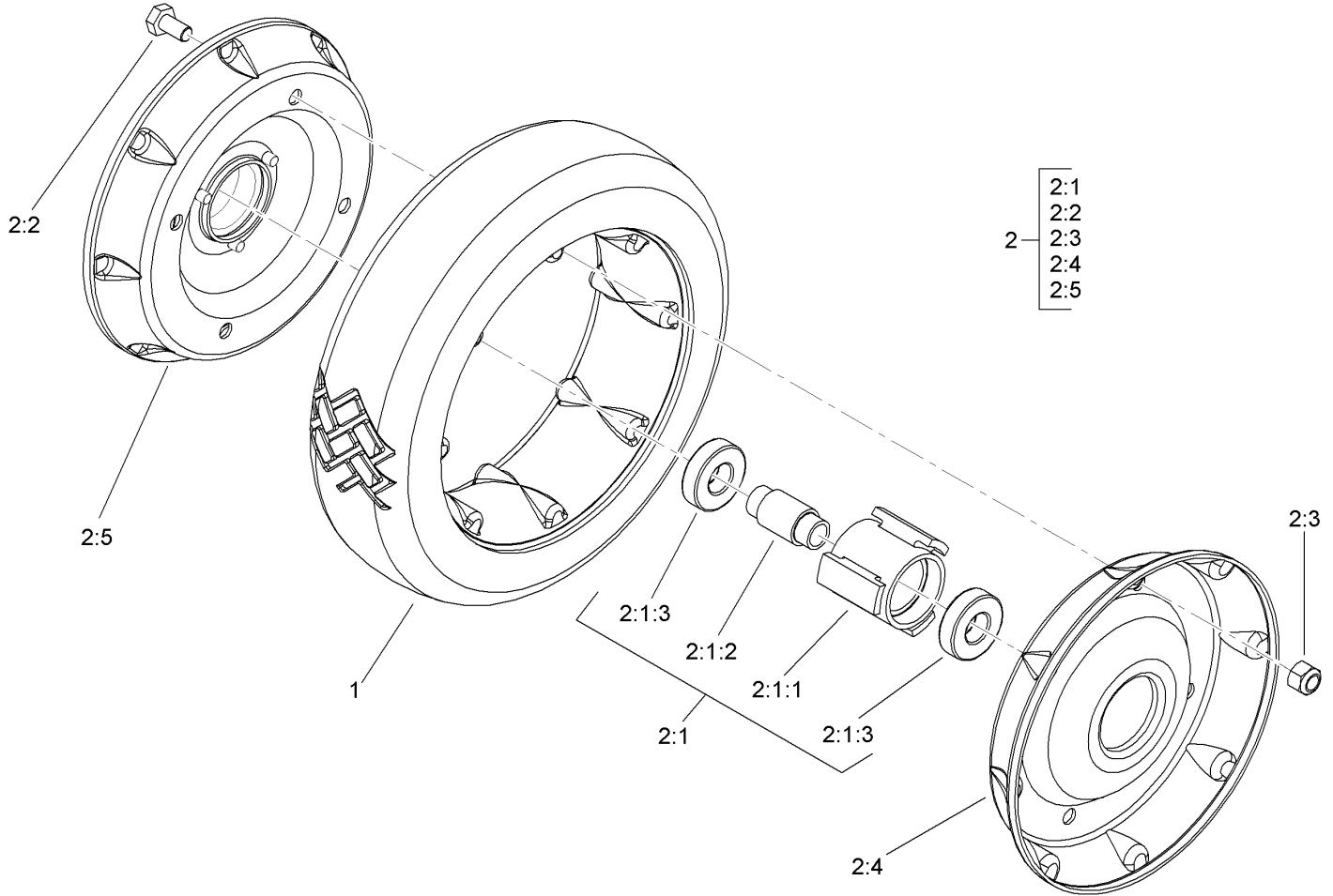

### Rear Wheel Assembly No. 100-2860

Ref	Part No.	Qty.	Description
1	53-7740	1	Tire
①2		1	Wheel ASM
①2:1		1	Hub And Bearing ASM
2:1:1	52-2410	1	Hub-Bearing
2:1:2	52-2440	1	Spacer-Bearing
2:1:3	52-2450	2	Bearing-Wheel
2:2	321-2	4	Screw-HH
2:3	3296-42	4	Nut-Lock, NI
2:4	53-7780-06	1	Plate-Wheel, Half
2:5	92-4957-06	1	Wheel Half And Gear ASM

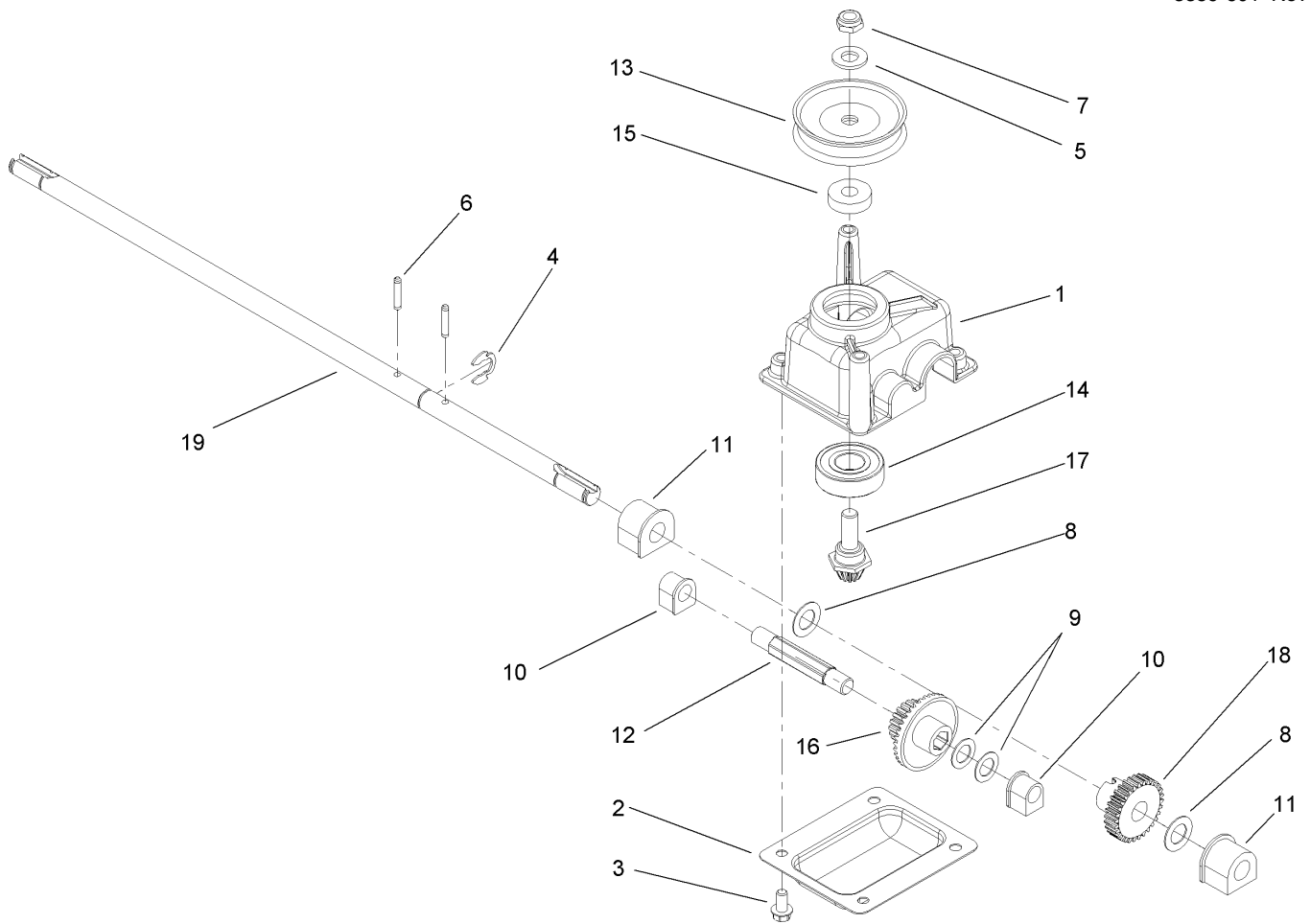
## Gear Case Assembly No. 108-8140

Ref	Part No.	Qty.	Description
1	104-7619	1	Case-Gear
2	614668-03	1	Cover-Case, Gear
3	32144-4	4	Screw-HWH
4	32151-68	1	Ring-Retaining
5	3256-24	1	Washer-Flat
6	3285-19	2	Pin-Groove
7	3296-5	1	Nut-Lock
8	36-4780	2	Washer-Plain
9	36-4791	2	Washer-Thrust
10	60-8750	2	Bushing
11	60-8850	2	Bushing
12	614696	1	Shaft-Intermediate
13	100-1176	2	Pulley-Half
14	100-1048	1	Bearing-Ball
15	62-6660	1	Spacer
16	104-1005	1	Gear-19T Spur, 37T Bevel
17	104-7667	1	Gear-Pinion, Bevel
18	104-1004	1	Gear-30T
19	108-8141	1	Shaft-Output

## Engine Assembly

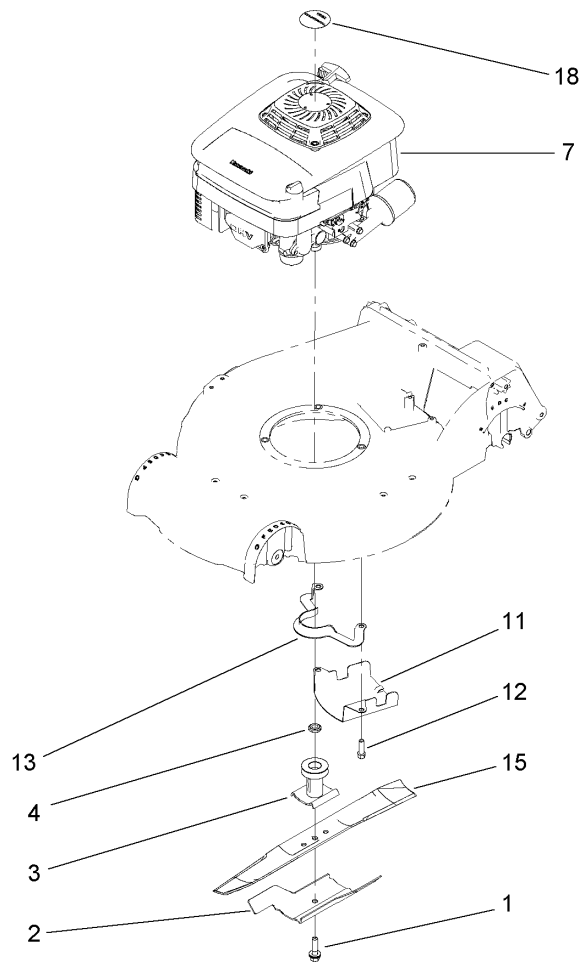
Ref	Part No.	Qty.	Description				
1	105-8579	1	Bolt-Blade				
2	105-6848-03	1	Accelerator-Blade				
3	106-3987	1	Blade Driver ASM				
4	106-3999	1	Spacer-Driver				
7	112-9990	1	Engine-Kawasaki, Fj180V-As28				
11	107-7489-03	1	Shield-Grass				
12	95-1727	3	Screw-Taptite				
13	108-8110-03	1	Guide-Belt				
15	108-3762-03	1	Blade-Recycling				
18	112-9966	1	Decal				

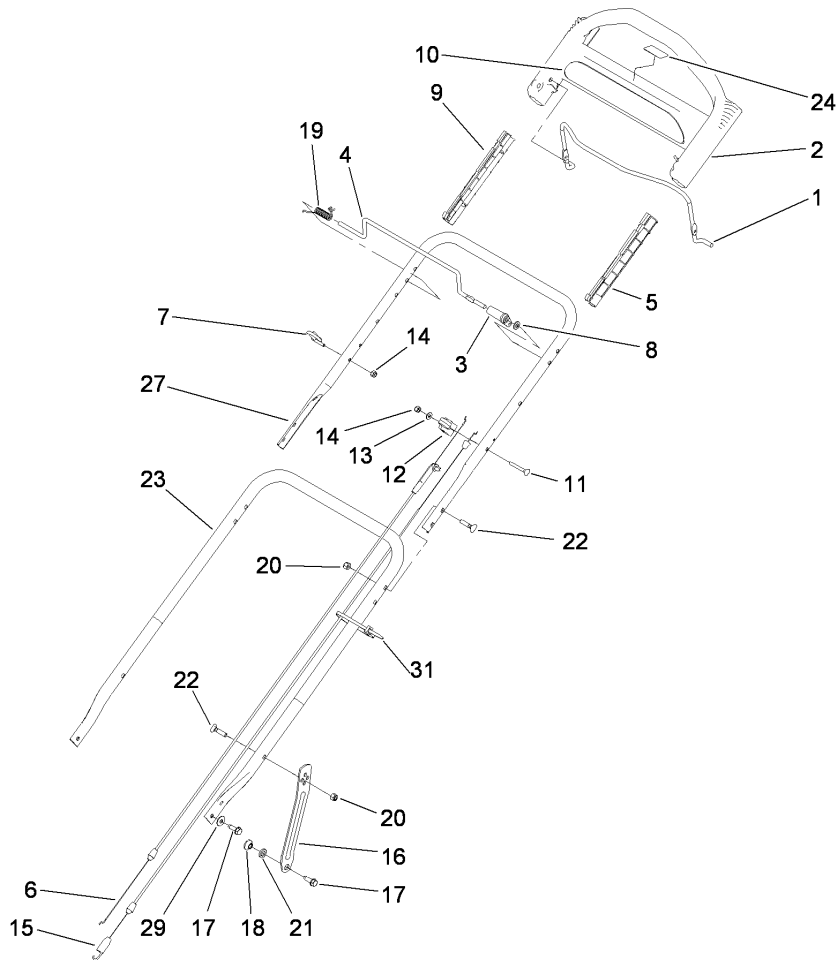

## Handle Assembly

Ref	Part No.	Qty.	Description
1	104-8679-03	1	Bail-Brake
2	104-8678	1	Handle-Control
3	99-1589	1	Lever-Traction
4	99-1588	1	Bar-Control, Traction
5	105-6842	1	Guide-LH
6	106-5750	1	Cable-Brake
7	86-9671	1	Guide-Rope
8	3256-23	1	Washer-Flat
9	105-6841	1	Guide-RH
10	108-8134	1	Decal-Handle
11	95-4453	1	Screw
12	99-5239	1	Anchor-Cable
13	3256-1	1	Washer-Flat
14	3296-42	2	Nut-Lock, NI
15	108-8158	1	Cable-Traction
16	108-8145-03	2	Support-Handle
17	701243	4	Screw-HWHTF
18	27-6600	2	Spacer-Coupling
19	104-8690	1	Spring-Torsion
20	3296-29	6	Nut-Lock, NI
21	55-9670	2	Washer
22	92-4095	6	Screw-Handle
23	114-3492-03	1	Handle-Lower
24	98-4387	1	Decal-Protection, Ear

Ref	Part No.	Qty.	Description
27	110-4874-03	1	Handle-Upper
29	3290-456	2	Washer-Belleville
31	614249	2	Strap-Tie

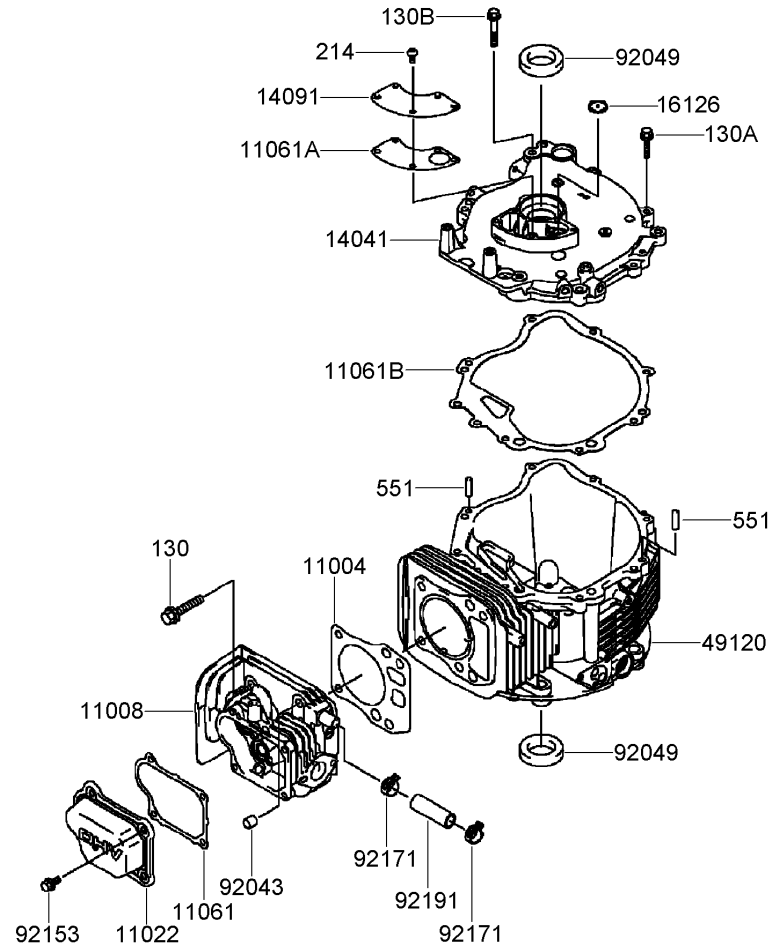

## Cylinder and Crankcase Assembly Kawasaki FJ180V-AS28

Ref	Part No.	Qty.	Description
● 11004	11004-7020	1	Gasket-Head
● 11008	11008-7025	1	Head-Cylinder
● 11022	11022-7005	1	Case-Rocker
● 11061	11061-7023	1	Gasket-Case, Rocker
● 11061A	11061-7031	1	Gasket-Breather
● 11061B	11061-7060	1	Gasket-Cover, Crankcase
● 14041	14041-7009	1	Cover
● 14091	14091-7010	1	Cover-Breather
● 16126	16126-7014	1	Valve-Breather
● 49120	49120-7082	1	Crankcase
● 92043	92043-7001	2	Pin
● 92049	92049-7008	2	Seal-Oil (28-44-9 Tc)
● 92153	92153-7043	4	Bolt (6X12)
● 92171	92171-7024	2	Clamp
● 92191	92191-7025	1	Tube (12X16X49)
● 130	130CA0840	4	Bolt-Flanged (8X40)
● 130A	130G0625	7	Bolt-Flanged (6X25)
● 130B	130G0635	1	Bolt-Flanged (6X35)
● 214	214B0510	5	Screw-Pan (5X10)
● 551	551A0612	2	Pin-Dowel (6X12)

--	--	--	--

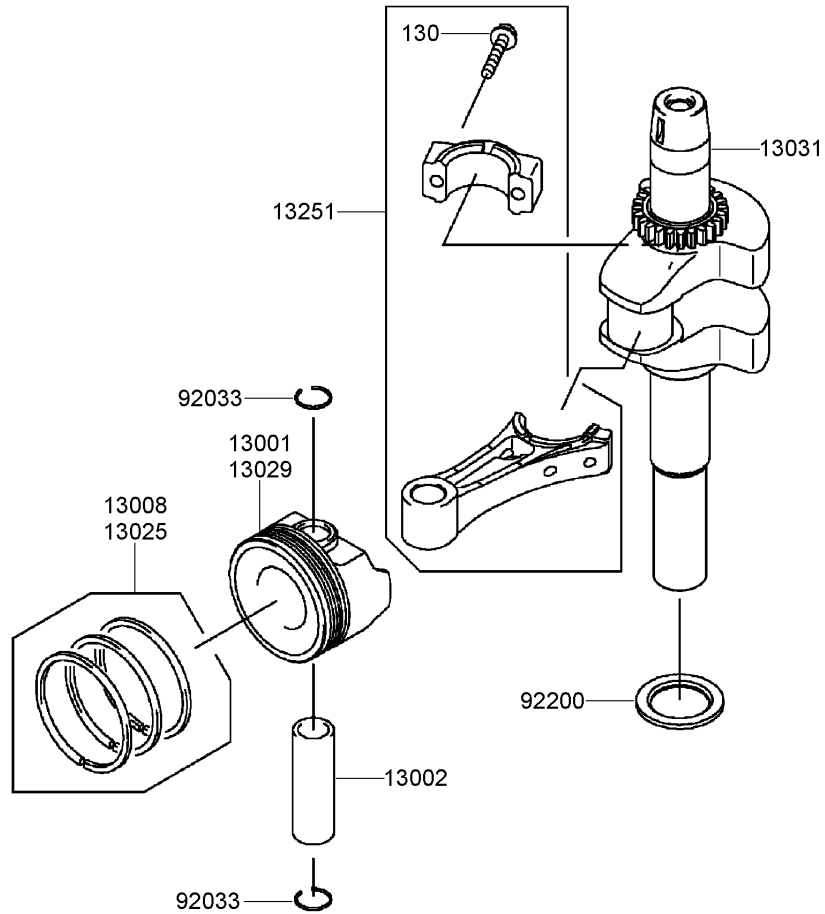

## Piston and Crankshaft Assembly Kawasaki FJ180V-AS28

Ref	Part No.	Qty.	Description
② 13001	13001-7022	1	Piston-Engine
② 13002	13002-7001	1	Pin-Piston
② 13008	13008-7002	1	Piston Ring Set
② 13025	13025-7006	1	Piston Ring Set (L 0.50)
② 13029	13029-7005	1	Piston-Engine (L 0.50)
② 13031	13031-7078	1	Crankshaft
② 13251	13251-7011	1	Connecting Rod ASM
② 92033	92033-7002	2	Ring-Snap
② 92200	92200-7042	1	Washer (28X41.5X2.5)
② 130	130G0630	2	Bolt-Flanged (6X30)

--	--	--	--

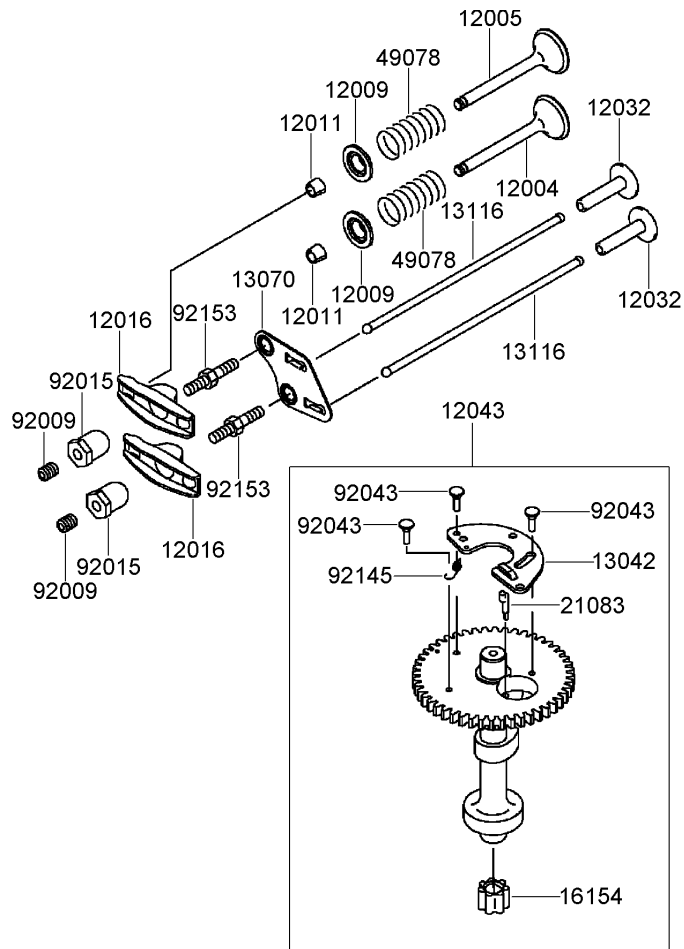

## Valve and Camshaft Assembly Kawasaki FJ180V-AS28

Ref	Part No.	Qty.	Description
②	12004	1	Valve-Intake
②	12005	1	Valve-Exhaust
②	12009	2	Retainer-Spring, Valve
②	12011	4	Collet
②	12016	2	Arm-Rocker
②	12032	2	Tappet
②	12043	1	Camshaft Valve ASM
②	13042	1	Weight
②	13070	1	Guide
②	13116	2	Rod-Push
②	16154	1	Rotor-Pump
②	21083	1	Arm
②	49078	2	Spring-Valve, Engine
②	92009	2	Screw
②	92015	2	Nut
②	92043	3	Pin
②	92145	1	Spring
②	92153	2	Bolt

--	--	--	--

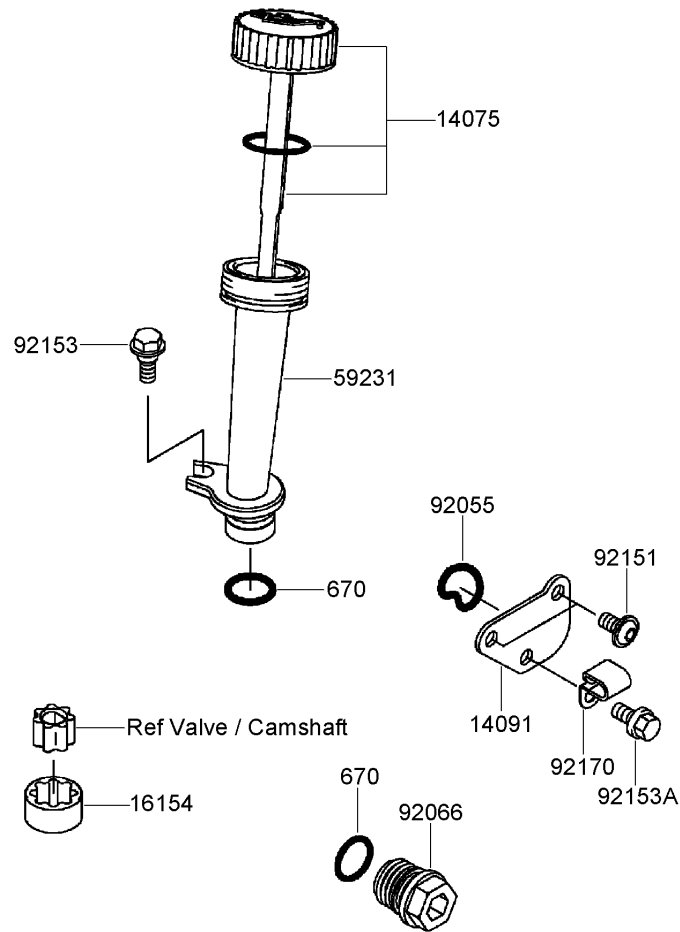

## Lubrication Equipment Assembly Kawasaki FJ180V-AS28

Ref	Part No.	Qty.	Description
② 14075	14075-7007	1	Cap ASM
② 14091	14091-7011	1	Cover, Oil Filter
② 16154	16154-7002	1	Rotor-Pump
② 59231	59231-7004	1	Filler
② 92055	92055-2151	1	O-Ring
② 92066	92066-7003	1	Plug
② 92151	92151-7012	2	Bolt (6X12)
② 92153	92153-7007	1	Bolt
② 92153A	92153-7043	1	Bolt (6X12)
② 92170	92170-1577	1	Clamp
② 670	670D2016	2	O-Ring (16Mm)

--	--	--	--

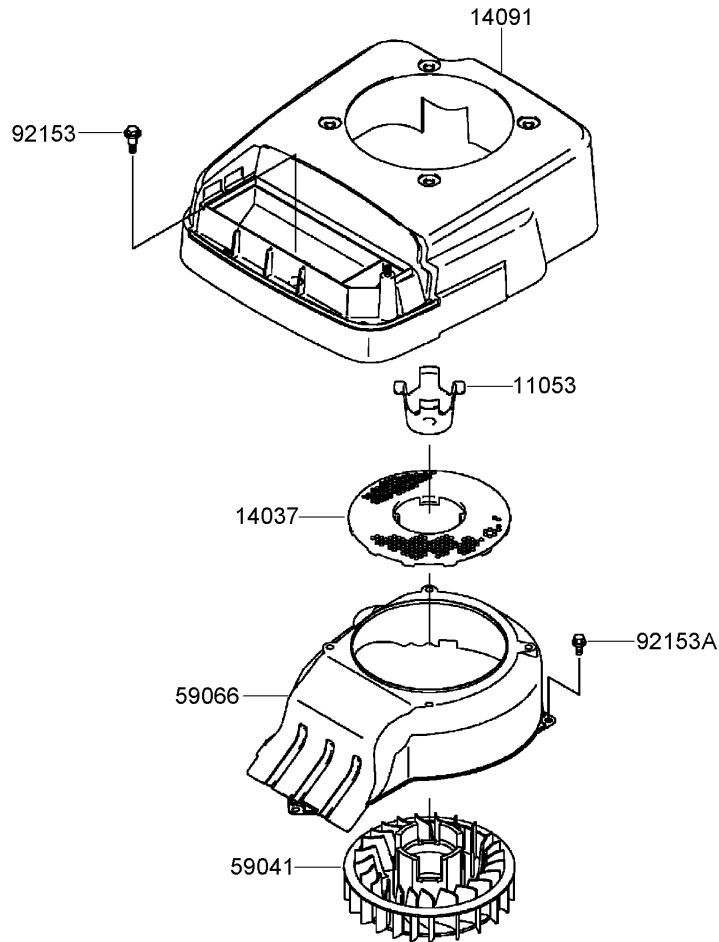

## Cooling Equipment Assembly Kawasaki FJ180V-AS28

Ref	Part No.	Qty.	Description				
② 11053	11053-7009	1	Bracket-Fan				
② 14037	14037-7017	1	Screen				
② 14091	14091-7046	1	Cover				
② 59041	59041-7009	1	Fan				
② 59066	59066-7016	1	Housing-Fan				
② 92153	92153-7008	1	Bolt				
② 92153A	92153-7043	1	Bolt (6X12)				

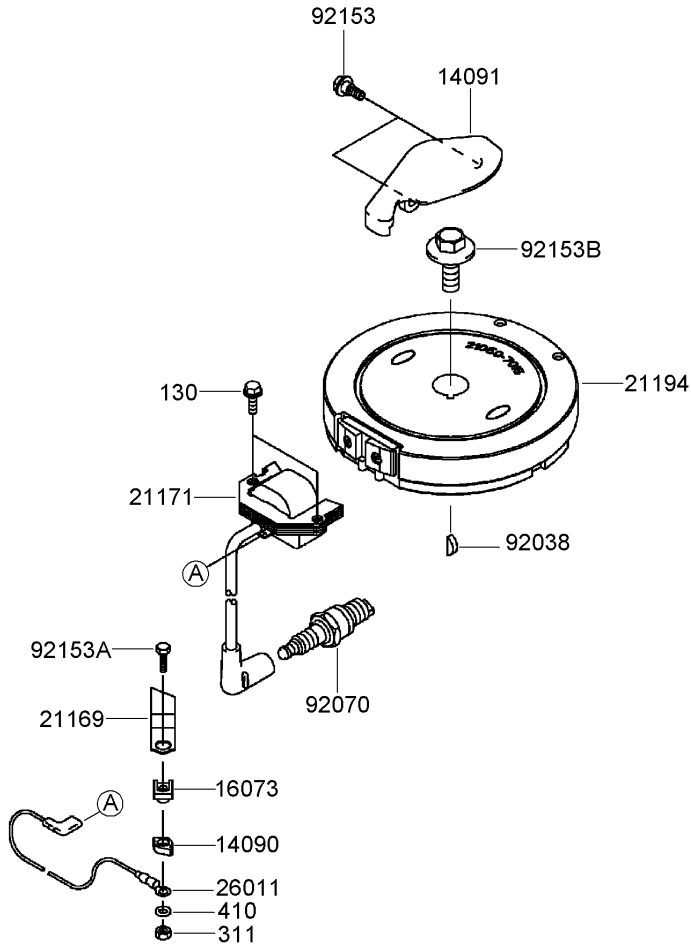

## Electric Equipment Assembly Kawasaki FJ180V-AS28

Ref	Part No.	Qty.	Description
②14090	14090-2108	1	Cover
②14091	14091-7036	1	Cover
②16073	16073-2192	1	Insulator
②21169	21169-2071	1	Terminal
②21171	21171-7030	1	Ignition Coil ASM
②21194	21194-7024	1	Flywheel
②26011	26011-7013	1	Wire-Lead
②92038	92038-2077	1	Key
②92070	92070-2088	1	Spark Plug, B P R 5E S (N G K) Solid
②92153	92153-7007	2	Bolt
②92153A	92153-7012	1	Bolt (4X16)
②92153B	92153-7030	1	Bolt (12X30)
②130	130B0620	2	Bolt-Flanged (6X20)
②311	311B0400	1	Nut-Hex (4Mm)
②410	410B0400	1	Washer-Plain, S (4Mm)

--	--	--	--

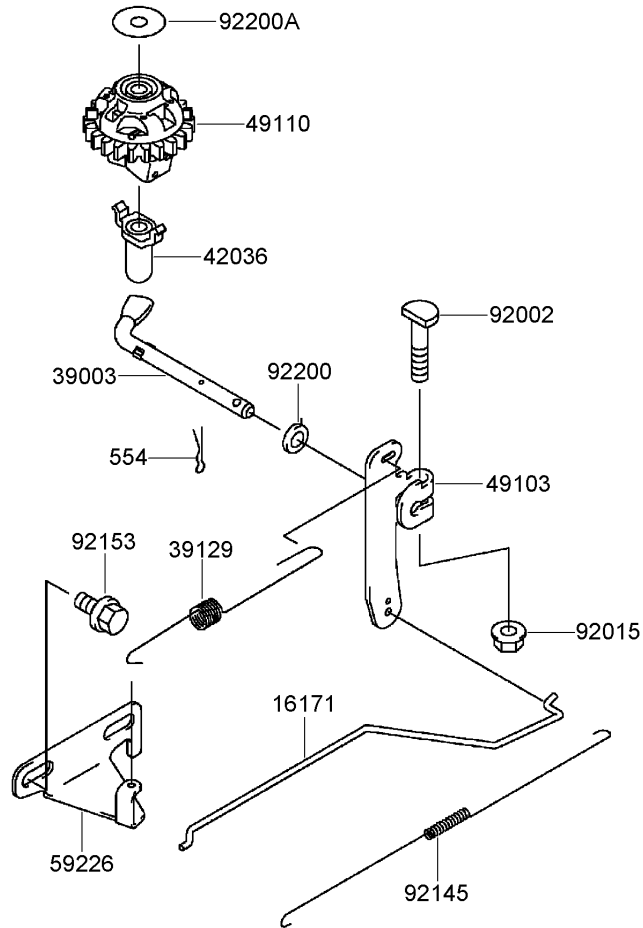

## Control Equipment Assembly Kawasaki FJ180V-AS28

Ref	Part No.	Qty.	Description
②16171	16171-7015	1	Link-Throttle
②39003	39003-7002	1	Arm-Pivot
②39129	39129-7007	1	Spring-Governor
②42036	42036-2051	1	Sleeve
②49103	49103-7005	1	Arm-Governor
②49110	49110-7002	1	Governor ASM
②59226	59226-7014	1	Panel-Control
②92002	92002-2269	1	Bolt (6X28)
②92015	92015-1193	1	Nut
②92145	92145-7025	1	Spring-Throttle
②92153	92153-7043	2	Bolt (6X12)
②92200	92200-2029	1	Washer (6.5X11.5X2.0)
②92200A	92200-2036	1	Washer (6.2X20X0.5)
②554	554A0600	1	Pin-Snap (1.2X21.2)

--	--	--	--

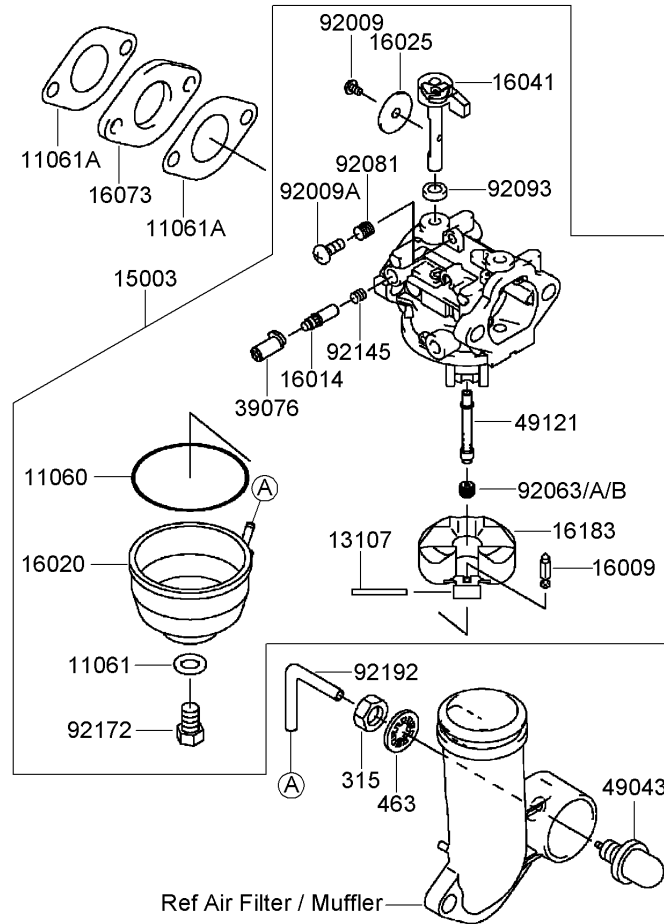

## Carburetor Assembly Kawasaki FJ180V-AS28

Ref	Part No.	Qty.	Description
● 11060	11060-2190	1	Gasket
● 11061	11061-7010	1	Gasket-Screw
● 11061A	11061-7015	2	Gasket-Insulator
● 13107	13107-7024	1	Shaft
● 15003	15003-7133	1	Carburetor ASM
● 16009	16009-2136	1	Needle-Jet
● 16014	16014-7008	1	Screw-Air, Pilot
● 16020	16020-7005	1	Chamber-Float
● 16025	16025-7007	1	Valve-Throttle
● 16041	16041-7019	1	Shaft-Carburetor
● 16073	16073-7006	1	Insulator
● 16183	16183-2002	1	Float ASM
● 39076	39076-7001	1	Limiter
● 49043	49043-7002	1	Pump-Priming
● 49121	49121-7012	1	Nozzle-Main
● 92009	92009-2083	1	Screw
● 92009A	92009-2349	1	Screw
● 92063	92063-7048	1	Jet-Main, No. 76
● 92063A	92063-7049	1	Jet-Main, No. 74
● 92063B	92063-7061	1	Jet-Main, No. 78
● 92081	92081-2234	1	Spring
● 92093	92093-2100	1	Seal
● 92145	92145-7015	1	Spring
● 92172	92172-7023	1	Screw

Ref	Part No.	Qty.	Description
● 92192	92192-7074	1	Tube (2.2X7.3X65)
● 315	315B1000	1	Nut-Hex, Fine (10Mm)
● 463	463H1000	1	Washer-Toothed (10Mm)

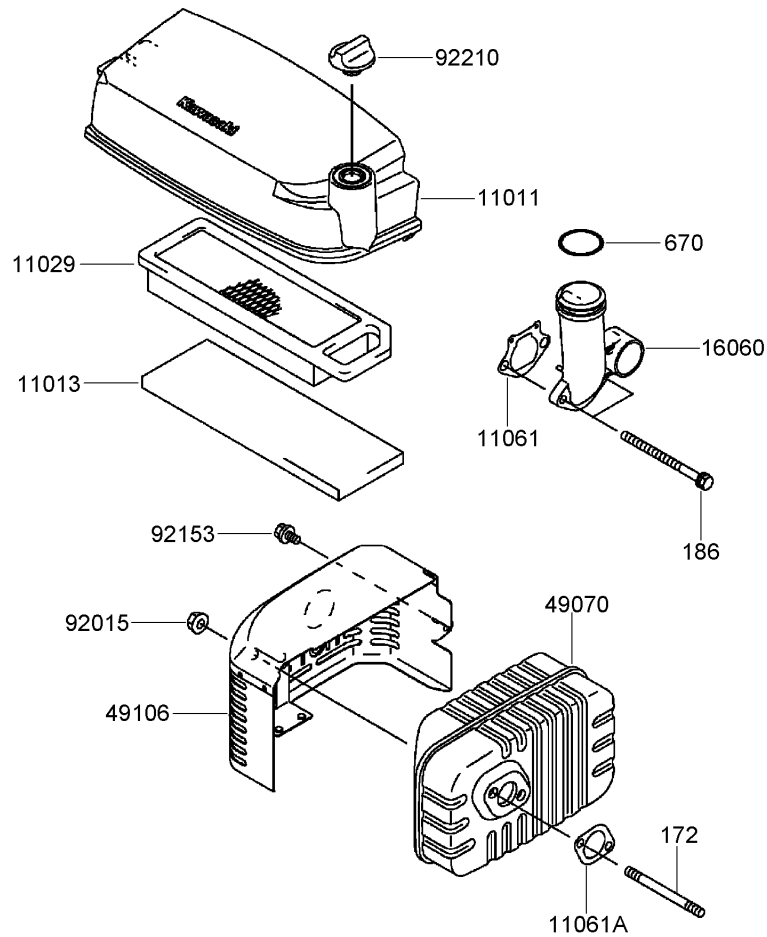

## Air Filter and Muffler Assembly Kawasaki FJ180V-AS28

Ref	Part No.	Qty.	Description
②11011	11011-7028	1	Case-Filter, Air
②11013	11013-7032	1	Element-Filter, Air
②11029	11029-7021	1	Air Filter Element ASM
②11061	11061-7012	1	Gasket-Pipe, Intake
②11061A	11061-7029	1	Gasket-Muffler
②16060	16060-7012	1	Pipe-Intake
②49070	49070-7022	1	Muffler
②49106	49106-7019	1	Cover-Muffler
②92015	92015-1193	2	Nut
②92153	92153-7023	1	Bolt (6X10 )
②92210	92210-7019	1	Nut
②172	172G0680	2	Bolt-Stud (6X80)
②186	186B0680	2	Bolt-Upset, Wp (6X80)
②670	670B3032	1	O-Ring (32Mm)

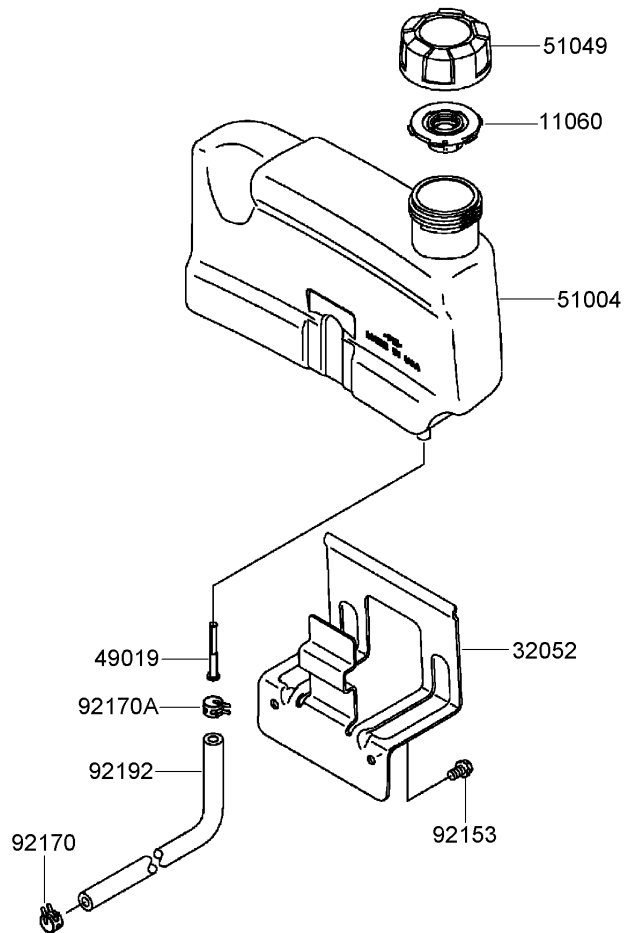

## Fuel Tank and Fuel Valve Assembly Kawasaki FJ180V-AS28

Ref	Part No.	Qty.	Description
②11060	11060-2145	1	Gasket
②32052	32052-7001	1	Bracket-Tank
②49019	49019-7003	1	Filter-Fuel
②51004	51004-7001	1	Tank-Fuel
②51049	51049-7002	1	Cap-Tank
②92153	92153-7023	2	Bolt (6X10 )
②92170	92170-2009	1	Clamp
②92170A	92170-2088	1	Clamp
②92192	92192-7033	1	Tube (6.35X12.7X330)



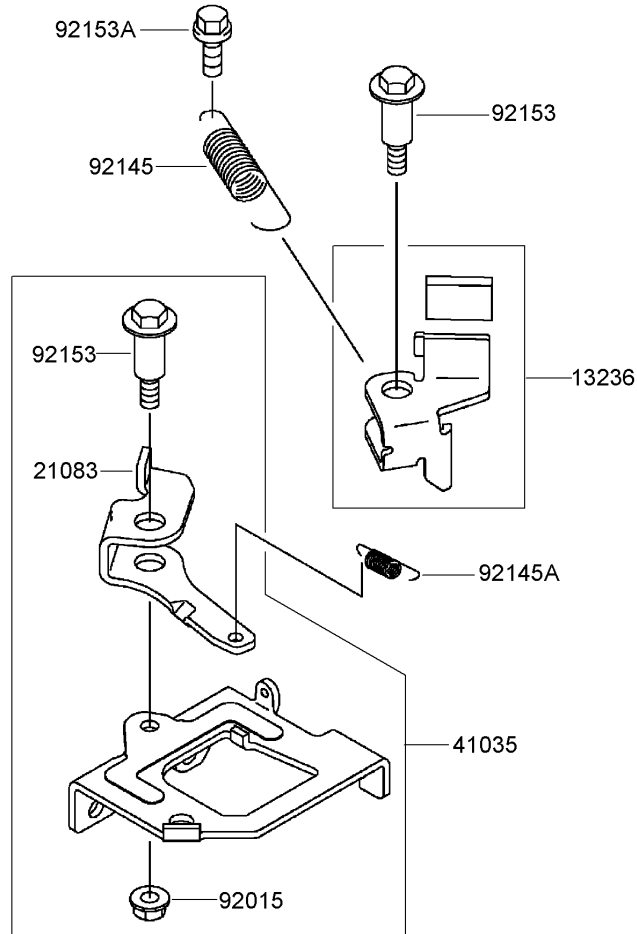

## Brake and Cover Assembly Kawasaki FJ180V-AS28

Ref	Part No.	Qty.	Description
②13236	13236-7008	1	Lever
②21083	21083-7016	1	Arm
②41035	41035-7005	1	Brake Panel ASM
②92015	92015-1193	1	Nut
②92145	92145-7023	1	Spring
②92145A	92145-7032	1	Spring
②92153	92153-7020	2	Bolt
②92153A	92153-7023	1	Bolt (6X10 )

--	--	--	--



# Attachments and Accessories

For 22164 - PT21 Lawn Mower

Product Name

Model/Part

Rear Bag Kit ..... 22159

# NOTES

# NOTES

