

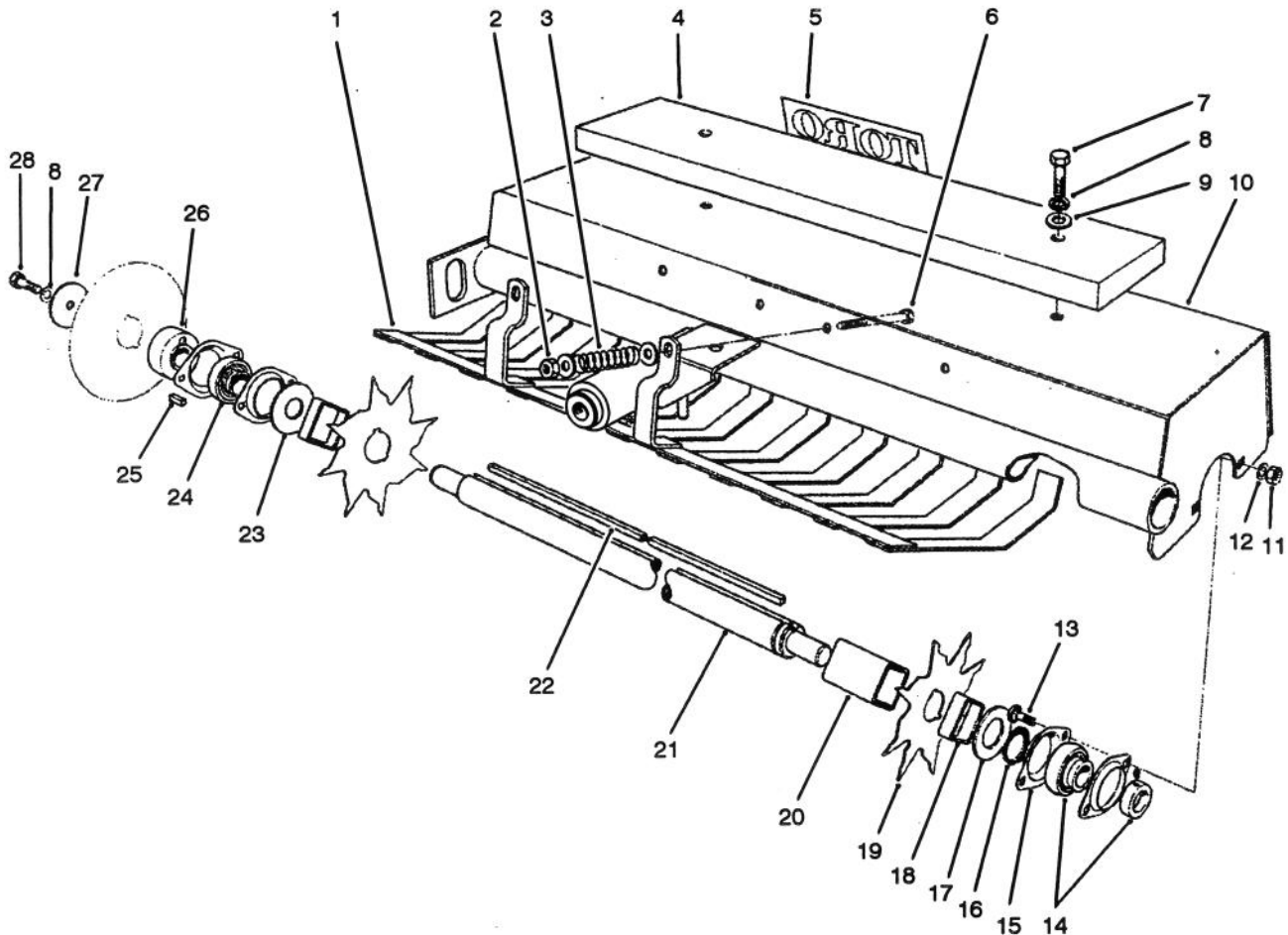

MODEL NO. 08856-30001 & UP	<b>PARTS CATALOG</b>
<b>SPIKER KIT</b> For Sand Pro 2000 & 5000	



T-0258

### FRAME ASSEMBLY

Ref. No.	Part No.	Description	No. Used
1	20-9140	Assembly - Fork, L.H.	1
*	20-9150	Assembly - Fork, R.H.	1
2	3296-39	Nut - Lock	4
3	20-9550	Spring - Compression	4
4	20-9430	Weight	2
5	18-6900	Decal - Toro	1
6	323-14	Screw - Cap, Hex. Hd.	4
7	323-10	Screw - Cap, Hex. Hd.	4
8	3253-21	Washer - Lock	6
9	3256-24	Washer - Flat	12
10	92-2522	Assembly - Frame, L.H.	1
*	92-2523	Assembly - Frame, R.H.	1
11	3217-6	Nut - Hex.	8
12	3253-4	Washer - Lock	8
13	3230-1	Bolt - Carriage	8
14	251-253	Bearing - w/Collar	2

Ref. No.	Part No.	Description	No. Used
15	251-255	Flange	8
16	32151-44	Retaining - Ring	2
17	20-9490	Washer	2
18	20-7400	Spacer - End	4
19	20-7380	Spike - Blade	24
20	20-9480	Spacer	20
21	20-9470	Shaft	2
22	20-9460	Key	2
23	20-9500	Washer	2
24	251-254	Bearing	2
25	20-9540	Key	2
26	20-9980	Hub	2
27	20-9530	Washer - End	2
28	323-7	Screw - Cap, Hex. Hd.	2
*	21-6000	Spiker - Depth Gauge	1

\*Not Illustrated

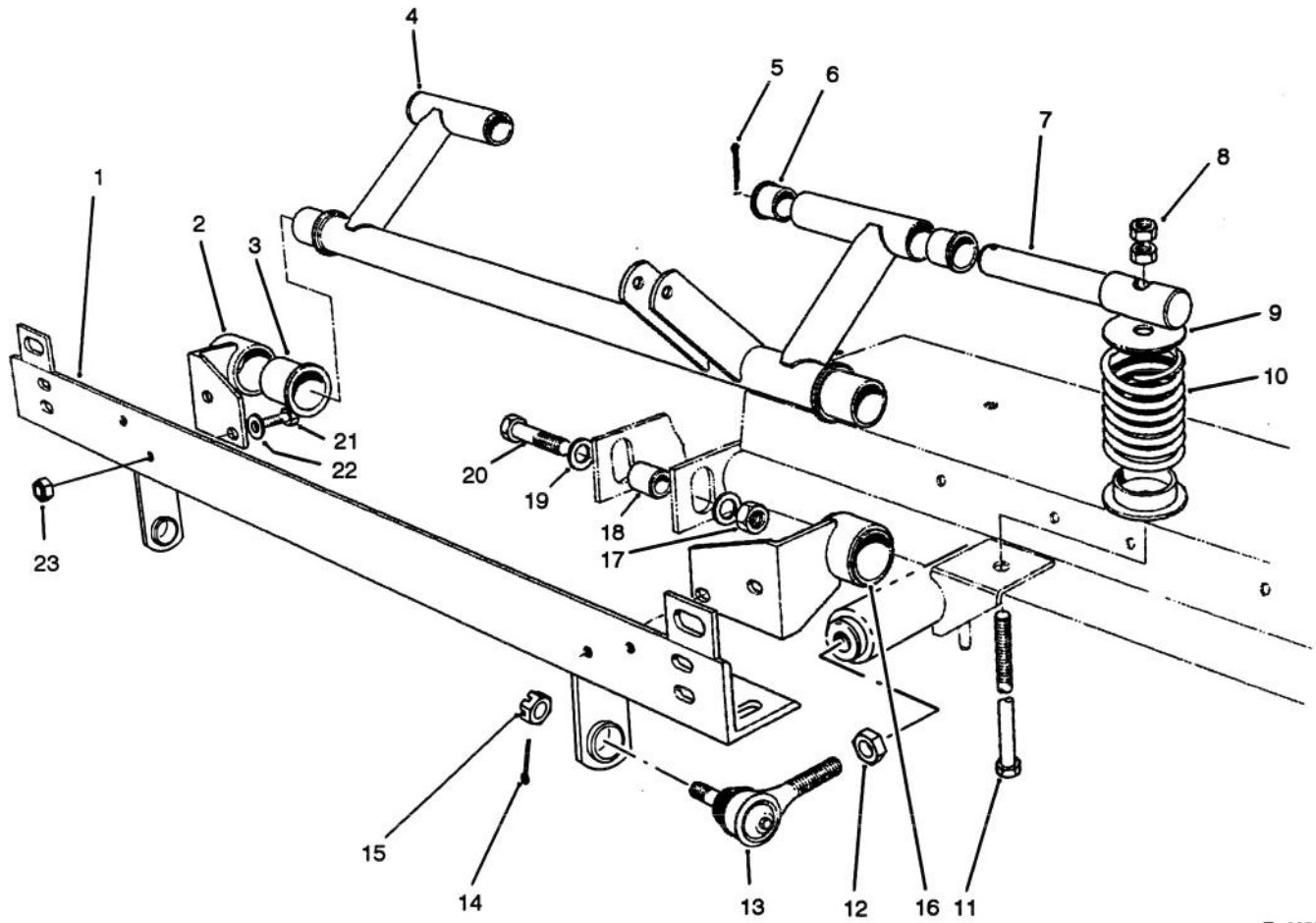

T-0259

### MOUNTING ASSEMBLY

Ref. No.	Part No.	Description	No. Used
1	92-2527	Mount	1
2	20-9270	Anchor R.H. (Incl. Ref. #3)	1
3	256-245	Bushing	2
4	92-2525	Arm - Lift (Incl. Ref. #6)	1
5	3272-13	Pin - Cotter	2
6	256-10	Bushing	2
7	20-9400	Pin - Actuating	2
8	3217-9	Nut - Hex.	4
9	20-9350	Mount - Spring	4
10	20-9420	Spring	2
11	20-9390	Rod - Actuating	2
12	20-9990	Nut	2

Ref. No.	Part No.	Description	No. Used
13	21-4010	Ball Joint (Incl. Ref. #14)	2
14	32136-3	Nut - Slotted	2
15	3272-7	Pin - Cotter	2
16	20-9260	Anchor - L.H. (Incl. Ref. #3)	1
17	3296-25	Nut - Lock	1
18	20-9410	Tube - Support, Center	1
19	3256-26	Washer - Flat	2
20	325-8	Screw - Cap, Hex. Hd.	1
21	323-6	Screw - Cap, Hex. Hd.	4
22	3256-24	Washer - Flat	4
23	3296-39	Nut - Lock	4