



21in Heavy-Duty Rear Bagger Lawn Mower

Model No. 22189 - 280000001 and up.

Parts Catalog

Ordering Replacement Parts

To order replacement parts, please supply the part number, the quantity, and the description of each part desired.

Understanding Reference Numbers

Each identified part in an illustration has a reference number. The reference number for a part also appears in the parts list, along with other information about the part.

This catalog uses two special reference number formats, one to indicate parts in a service assembly and another to indicate the quantity of a given part in an illustration.

Service Assembly Reference Numbers

Parts in service assemblies have reference numbers in the form a:b. The a represents the reference number of the entire service assembly and the b represents a sequential number unique to each part within the service assembly.

For example, a wheel assembly might be identified by reference number 6, the tire by 6:1, the valve by 6:2, and the wheel by 6:3. When you order the assembly identified by reference number 6, you receive all parts identified by reference numbers 6:1, 6:2, and 6:3. However, you may also order any part individually. Reference numbers of this type appear in illustrations and in part lists.

Reference Numbers Indicating Quantity

In an illustration, if a reference number indicates more than one part, the reference number has the form nX y. The n represents the quantity of the part, the X is the multiplication symbol, and the y represents the reference number.

For example, in an illustration, the reference number 2X 37 means that two of the parts identified by reference number 37 are indicated.

Contents

Description	Page	Description	Page
Housing Assembly 3	Valve and Camshaft Assembly Kawasaki FJ180V-AS30 13
Front Wheel and Tire Assembly No. 100-2870 4	Lubrication Equipment Assembly Kawasaki FJ180V-AS30 14
Gear Case Assembly No. 110-2100 5	Cooling Equipment Assembly Kawasaki FJ180V-AS30 15
Blade Brake Clutch Assembly 6	Electric Equipment Assembly Kawasaki FJ180V-AS30 16
Engine and Fuel Tank Assembly 7	Control Equipment Assembly Kawasaki FJ180V-AS30 17
Handle Assembly 8	Carburetor Assembly Kawasaki FJ180V-AS30 18
Rear Suspension Assembly 9	Air Filter and Muffler Assembly Kawasaki FJ180V-AS30 19
Grass Bag Assembly No. 110-2140 10	Starter Assembly Kawasaki FJ180V-AS30 20
Cylinder and Crankcase Assembly Kawasaki FJ180V-AS30 11	Label Assembly Kawasaki FJ180V-AS30 21
Piston and Crankshaft Assembly Kawasaki FJ180V-AS30 12		

Part Description Abbreviations

Part descriptions in this catalog may include the following abbreviations.

AR. as required	HYD. hydraulic
ASM. assembly	LH. left hand
BBC. blade brake clutch	NI. nylon insert
CARR. carriage	NPTF. national pipe thread fine
DEG. degrees	PFH. phillips flat head
EXT. external	PPH. phillips pan head
FH. flat head	PPHTF. phillips pan head thread forming
GA. gauge	PRH. phillips round head
HD. heavy-duty	PTH. phillips truss head
HF. hex flange	PTO. power-take-off
HH. hex head	RH. right hand
HHF. hex head flange	ROPS. roll-over protection system
HHFTF. hex head flange thread forming	SFH. slotted fillister head
HJ. hex jam	SHH. slotted hex head
HLH. hex lag head	SHWH. slotted hex washer head
HOC. height-of-cut	SPH. slotted pan head
HSBH. hex socket button head	SQH. square head
HSFH. hex socket flat head	SRH. slotted round head
HSH. hex socket head	STD. standard
HWH. hex washer head	TAP. self tapping
HWHTF. hex washer head thread forming	TTH. torx truss head

Footnotes

- ❶ Not illustrated
- ❷ Not serviced separately
- ❸ Obtain from your local Kawasaki dealer

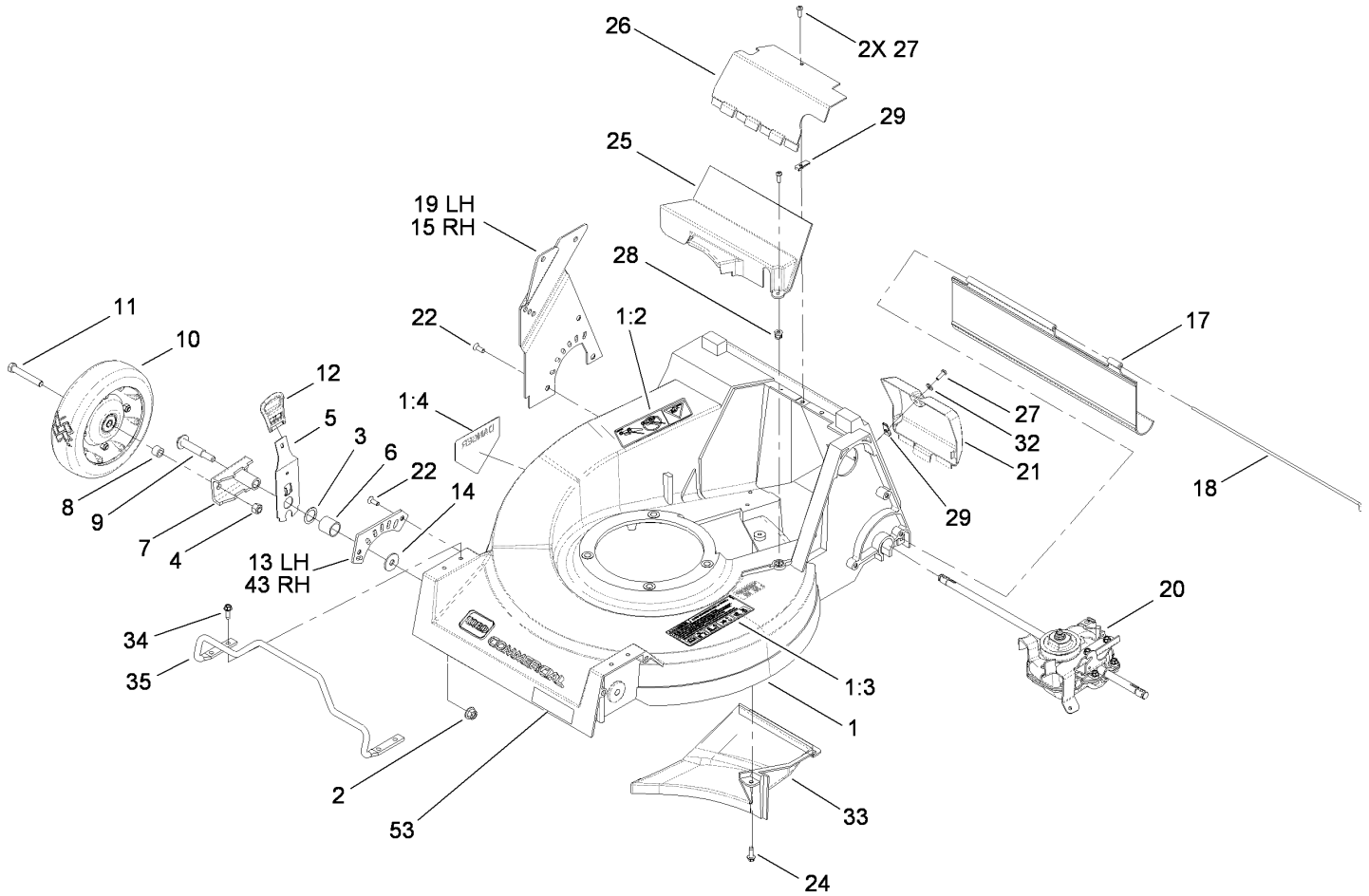

Housing Assembly

Ref	Part No.	Qty.	Description
1	115-0991	1	Deck ASM
1:2	110-4977	1	Decal-Danger
1:3	110-4989	1	Decal-Warning
1:4	43-8480	1	Decal-Danger
2	54-9190	2	Nut-Lock
3	115-0972	2	Washer
4	32152-2	2	Nut-Lock, Cone
5	115-0980	2	Front Spring Arm ASM
6	75-5310	2	Spacer-Bearing
7	61-8300	2	Arm-Pivot, Front
8	52-2480	2	Spacer-Wheel
9	114-3468	2	Screw-Shoulder
10	100-2870	2	Wheel And Tire ASM
11	323-12	2	Screw-HH
12	110-0549	2	Knob-HOC
13	115-0960	1	Plate-Front HOC, LH
14	115-0956	2	Washer
15	115-0978-01	1	Plate-Rear HOC, RH
17	110-0509	1	Shield-Trailing
18	33-3202	1	Rod-Shield
19	115-0977-01	1	Plate-Rear HOC, LH
20	110-2100	1	Gear Case ASM
21	107-4288	1	Door-Access, Rear
22	32144-17	10	Screw-HH

Ref	Part No.	Qty.	Description
24	49-2040	4	Screw-HWHTF
25	107-4297	1	Cover-Belt, Lower
26	107-4298	1	Cover-Belt, Upper
27	32144-32	3	Screw
28	611380	1	Nut-Clip
29	3290-171	2	Nut-Type J
32	3256-14	1	Washer-Flat
33	115-0973	1	Baffle-Chute, Floor
34	49-2040	4	Screw-HWHTF
35	110-4876	1	Guard-Engine
43	115-0961	1	Plate-Front HOC, RH
53	68-7410	1	Decal-Blade

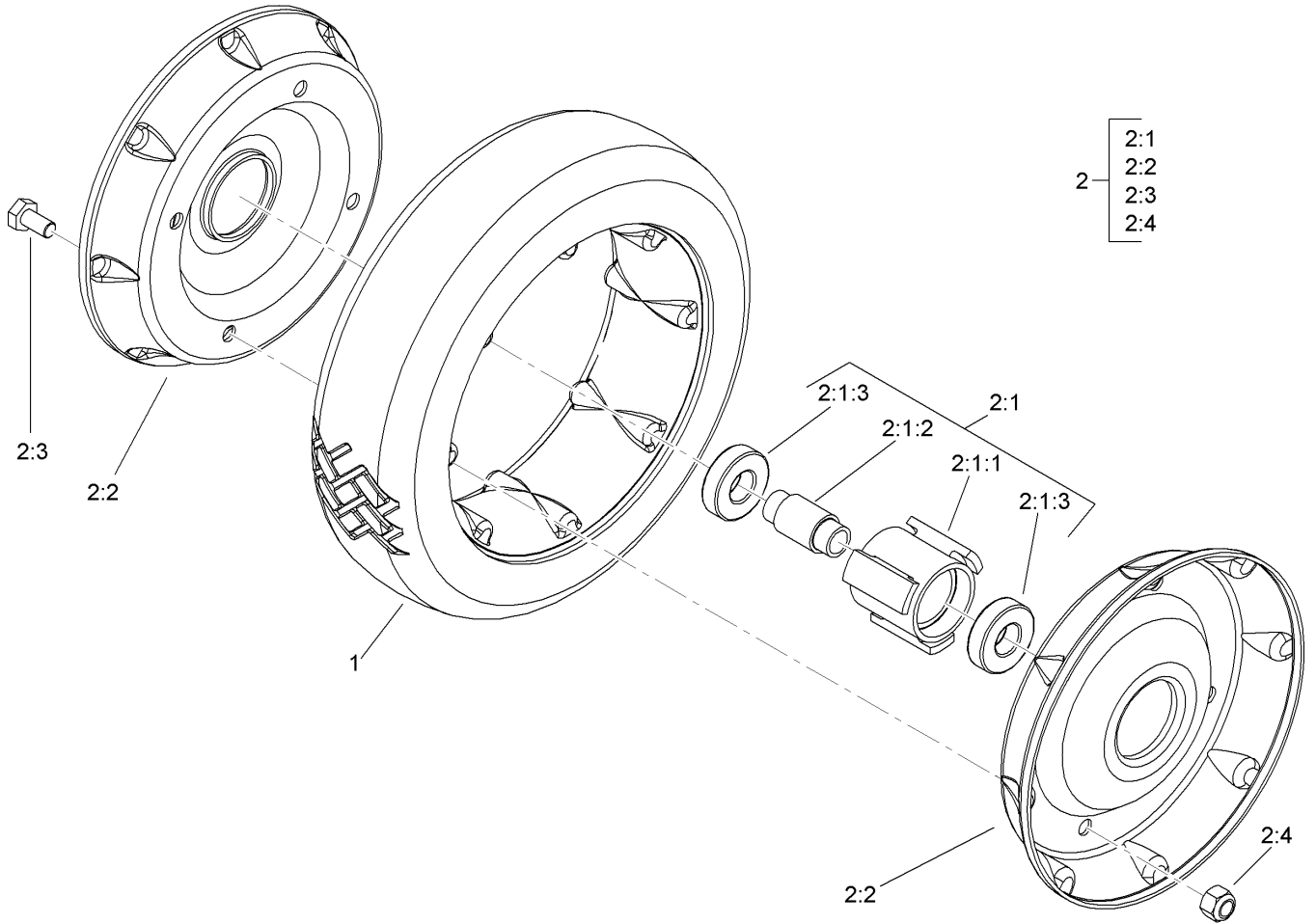

Front Wheel and Tire Assembly No. 100-2870

Ref	Part No.	Qty.	Description
1	53-7740	1	Tire
2		1	Wheel ASM
2:1		1	Hub And Bearing ASM
2:1:1	52-2410	1	Hub-Bearing
2:1:2	52-2440	1	Spacer-Bearing
2:1:3	52-2450	2	Bearing-Wheel
2:2	53-7780-06	2	Plate-Wheel, Half
2:3	321-2	4	Screw-HH
2:4	3296-42	4	Nut-Lock, NI

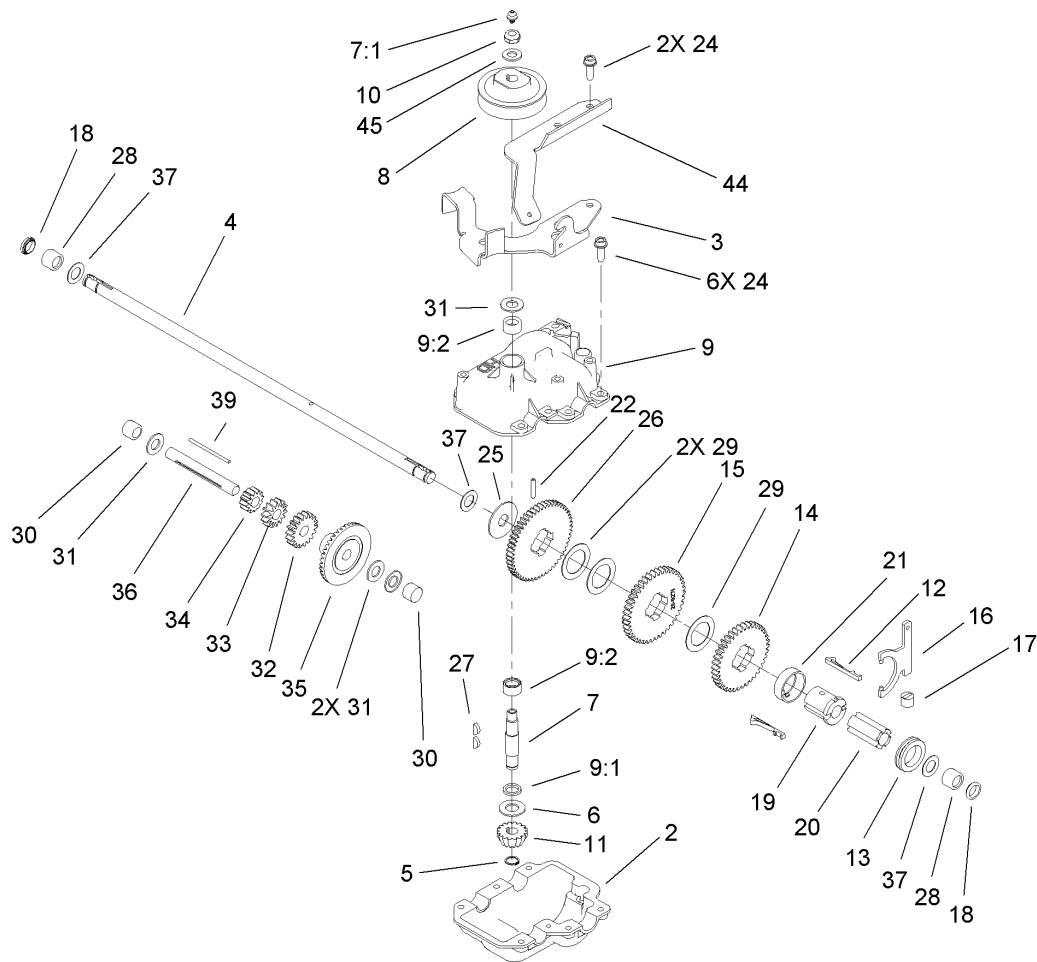

Gear Case Assembly No. 110-2100

Ref	Part No.	Qty.	Description
2	74-1920	1	Case-Gear, Lower
3	49-8461-03	1	Bracket-Guide, Belt
4	74-1890	1	Shaft-Output
5	32151-57	1	Ring-Retaining
6	47-2910	1	Washer-Thrust
7	13-5149	1	Input Shaft ASM
7:1	302-63	1	Zerk
8	39-6740	1	Pulley
9	13-9739	1	Upper Gearcase ASM
9:1	47-7260	1	Seal
9:2	47-7270	2	Bearing
10	3296-5	1	Nut-Lock
11	39-6660	1	Pinion-Bevel
12	29-9330	2	Key-Shift
13	29-9340	1	Collar-Shift
14	42-4740	1	Gear-38T
15	29-9271	1	Gear-42T
16	60-8870	1	Yoke-Shift
17	29-9570	1	Bushing-Yoke
18	47-6730	2	Seal-Oil
19	55-8010	1	Sleeve-Gear
20	39-6720	1	Sleeve
21	55-8020	1	Retainer-Key
22	3285-19	1	Pin-Groove

Ref	Part No.	Qty.	Description
24	49-2040	8	Screw-HWHTF
25	29-9690	1	Washer
26	46-3560	1	Gear
27	3257-1	2	Key-Woodruff
28	48-2060	2	Bearing-Roller
29	36-4770	3	Washer
30	252-103	2	Bearing-Closed
31	36-4792	4	Washer-Thrust
32	39-6650	1	Gear-18T
33	46-3550	1	Gear-14T
34	46-3540	1	Gear-12T
35	74-1760	1	Gear-Bevel
36	53-7950	1	Shaft-Intermediate
37	36-4780	3	Washer-Plain
39	39-7842	1	Key
44	108-2648-03	1	Arm-Actuating, Gear Case
45	3256-45	1	Washer-Flat

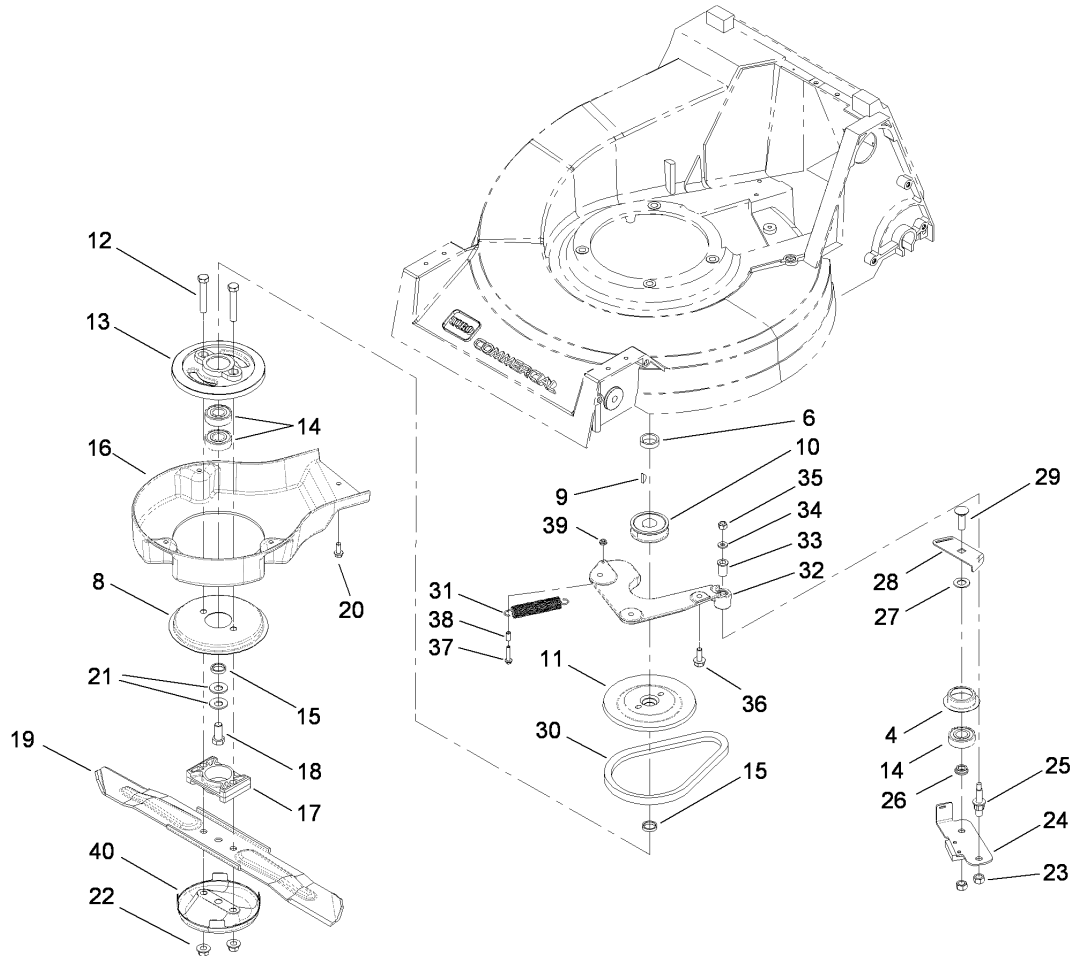

Blade Brake Clutch Assembly

Ref	Part No.	Qty.	Description
4	108-3790	1	Retainer-Belt
6	110-2142	1	Spacer-Pulley
8	108-3787	1	Disc
9	3257-17	1	Key-Woodruff
10	56-6180	1	Pulley-Driver
11	107-4277-03	1	Pulley-Driver, Upper
12	104-5936	2	Screw-HH
13	107-0754	1	Drum
14	100-1048	3	Bearing-Ball
15	107-4293	2	Spacer-Plate, BBC
16	110-0508	1	Shield-BBC
17	107-4275	1	Spacer-Blade
18	3212-4	1	Screw-HH
19	91-2256-03	1	Blade-21 Inch
20	32144-85	4	Screw-HWH
21	1-603610	2	Washer-Spring
22	54-9190	2	Nut-Lock
23	603773	2	Nut
24	107-7477	1	Brake Arm ASM
25	107-0759	1	Bolt-Shoulder
26	107-0758	1	Spacer-Bearing
27	605256	1	Washer
28	107-7471	1	Plate-Guide
29	3231-25	1	Screw-CARR

Ref	Part No.	Qty.	Description
30	110-1790	1	Belt-BBC
31	115-4471	1	Spring-Tension, Brake
32	107-4280	1	Plate-Mounting, BBC
33	107-0797	1	Bushing
34	3256-16	1	Washer-Flat
35	3296-42	1	Nut-Lock, NI
36	33104-020	3	Screw-HHF
37	32144-9	1	Screw-TAP
38	107-4292	1	Spacer-BBC
39	3296-27	1	Nut-Lock, NI
40	80-2770	1	Cup-Scalp, Anti

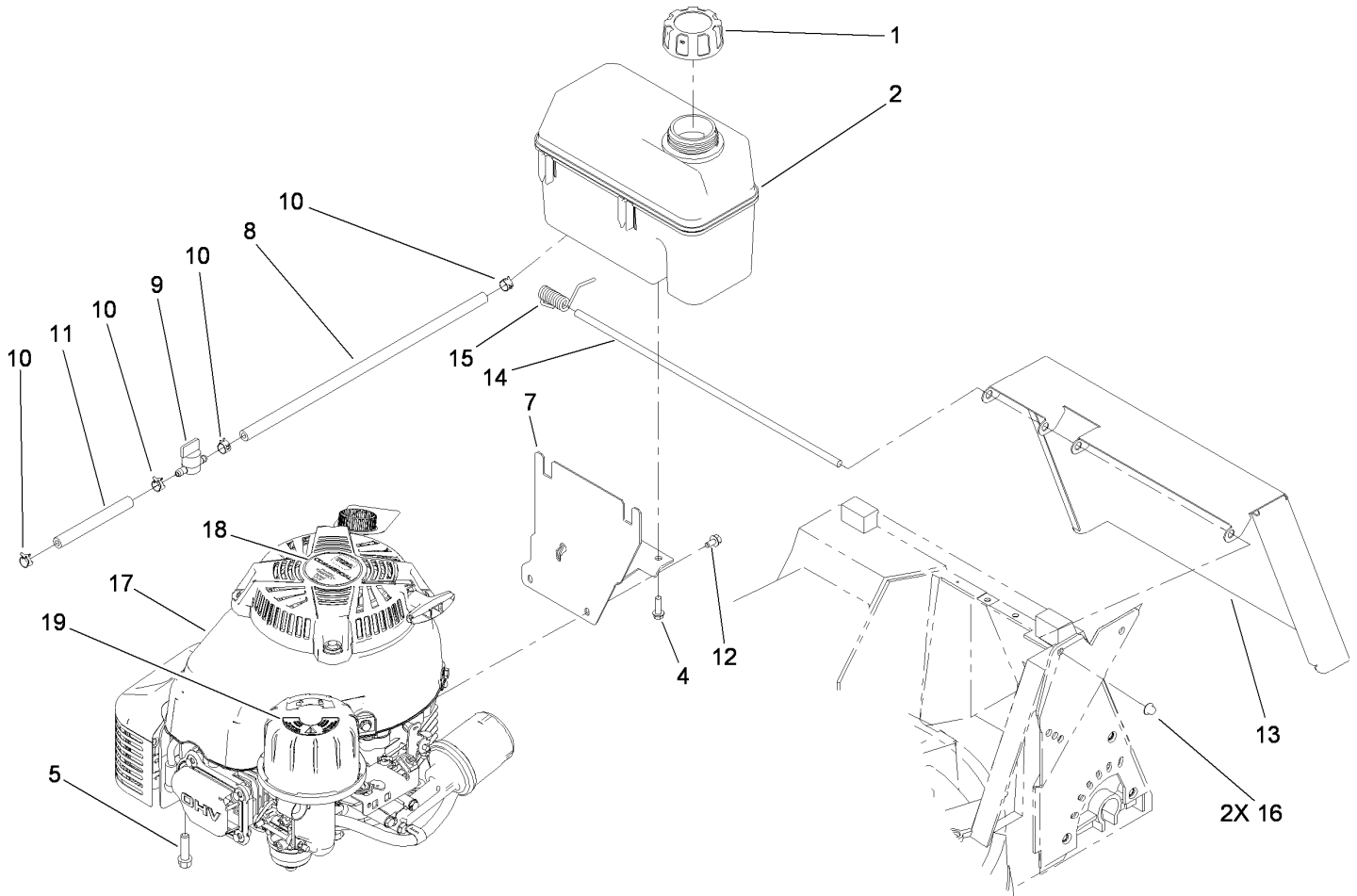

Engine and Fuel Tank Assembly

Ref	Part No.	Qty.	Description
1	93-7198	1	Gas Cap ASM
2	106-0625	1	Tank-Fuel
4	46-8091	2	Screw-HWH
5	95-1727	4	Screw-Taptite
7	115-0954-03	1	Tank Mount ASM
8	114-3766	1	Hose-Fuel
9	1-603770	1	Valve-Fuel
10	2412-98	4	Clamp
11	107-0588	1	Hose-Fuel
12	104-2628	3	Screw-HWH
13	114-3445-03	1	Door-Discharge, Rear
14	107-4286	1	Rod-Door
15	110-5005	1	Spring-Torsion, Door
16	32112-1	2	Pushnut-Cap, Washer
18	112-9967	1	Decal
17	110-5048	1	Engine-Kawasaki, Fj180V-As30
19	114-3415	1	Decal-Air Cleaner

Ref	Part No.	Qty.	Description

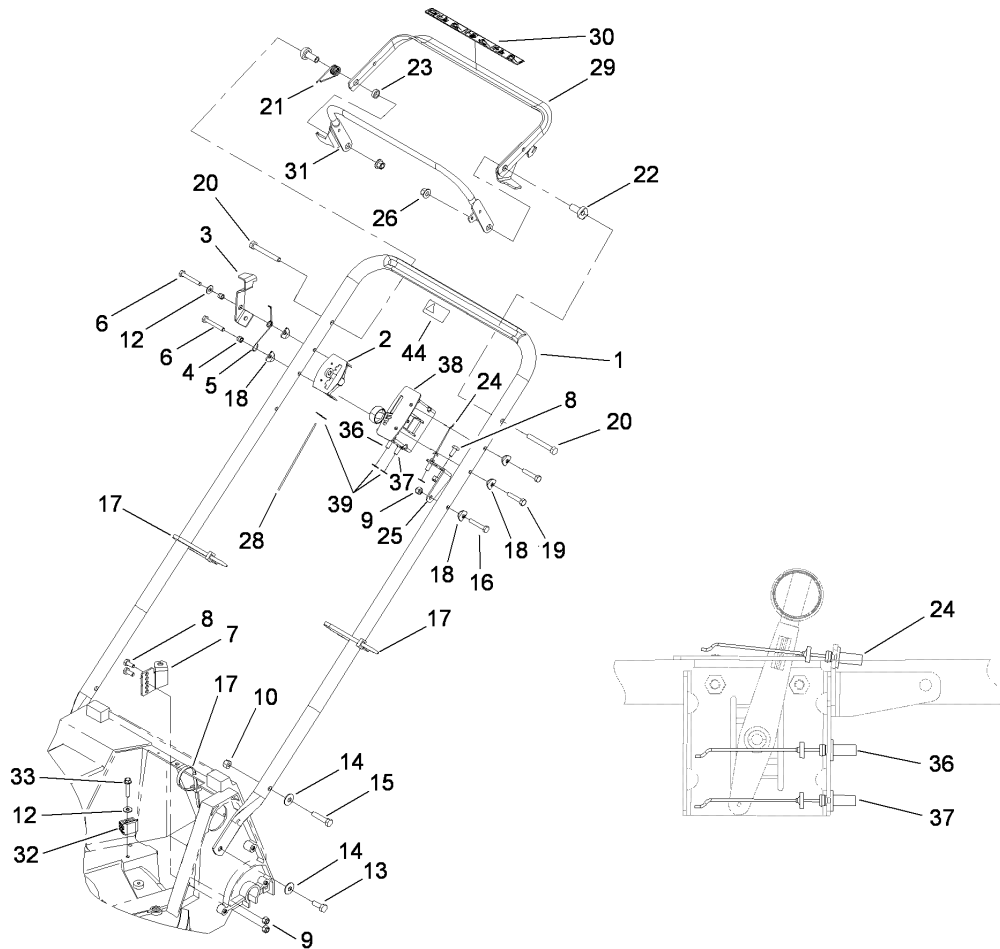

Handle Assembly

Ref	Part No.	Qty.	Description
1	107-4162-03	1	Handle
2	110-5026	1	Control-Shift
3	115-0999-01	1	Latch-Lever, BBC
4	110-0542	2	Spacer-Flange
5	115-0996	1	Spring-Torsion, Latch
6	321-10	2	Screw-HH
7	115-4453	1	Anchor-Cable
8	321-3	3	Screw-HH
9	3296-42	4	Nut-Lock, NI
10	3296-29	4	Nut-Lock, NI
12	3256-1	2	Washer-Flat
13	322-4	2	Screw-HH
14	3290-456	4	Washer-Belleville
15	322-7	2	Screw-HH
16	321-9	1	Screw-HH
17	3290-378	5	Tie-Cable
18	115-0995	5	Washer
19	321-13	2	Screw-HH
20	322-12	2	Screw-HH
21	115-0993	1	Spring-Torsion
22	49-1631	2	Spacer-Support
23	59-4310	1	Spacer
24	107-4296	1	Cable-BBC
25	115-4455	1	Bracket-Cable, BBC

Ref	Part No.	Qty.	Description
26	3296-58	2	Nut-Lock, NI
28	107-4295	1	Cable-Shift
29	115-4454-03	1	Traction Bail ASM
30	110-2114	1	Decal-Control
31	115-4452-03	1	BBC Bail ASM
32	92-7729	1	Anchor-Cable, Upper
33	32144-110	1	Screw-HWH
36	107-4294	1	Cable-Traction
37	110-4923	1	Throttle Cable ASM
38	108-2645	1	Control-Head, Throttle
39	32151-86	4	E-Ring
44	98-4387	1	Decal-Protection, Ear

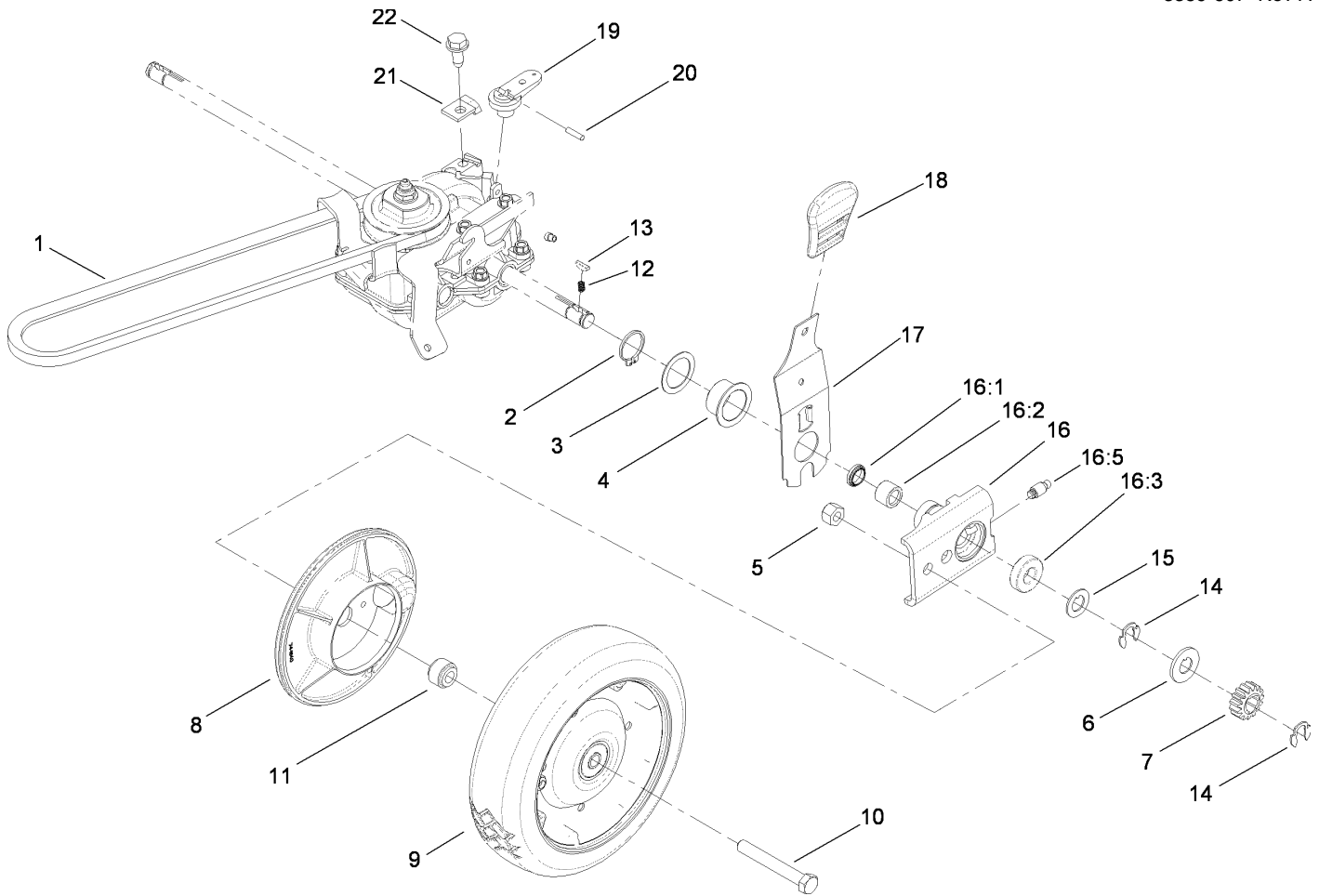

Rear Suspension Assembly

Ref	Part No.	Qty.	Description
1	612652	1	V-Belt
2	32151-36	2	Ring-Retaining
3	74-1810	2	Washer
4	115-0966	2	Bushing-Flange
5	32152-2	2	Nut-Lock, Cone
6	62-3830	2	Washer-Thrust, Outer
7	39-9160	2	Gear-Pinion
8	74-1640	2	Cover-Wheel
9	100-2860	2	Wheel And Tire ASM
10	323-13	2	Screw-HH
11	74-1650	2	Spacer-Cover, Wheel
12	39-9650	2	Spring-Compression
13	612066	2	Key
14	32151-68	4	Ring-Retaining
15	49-7700	2	Washer-Thrust, Outer
16	74-1851	2	Pivot Arm ASM
16:1	47-6730	1	Seal-Oil
16:2	48-2060	1	Bearing-Roller
16:3	52-2450	1	Bearing-Wheel
16:5	92-6316	1	Zerk
17	115-0979	2	Rear Spring Arm ASM
18	110-0549	2	Knob-HOC
19	29-9560	1	Lever-Shift
20	32121-99	1	Pin-Coil

Ref	Part No.	Qty.	Description
21	62-3720	1	Clamp-Cable
22	32144-70	1	Screw-HWHTF

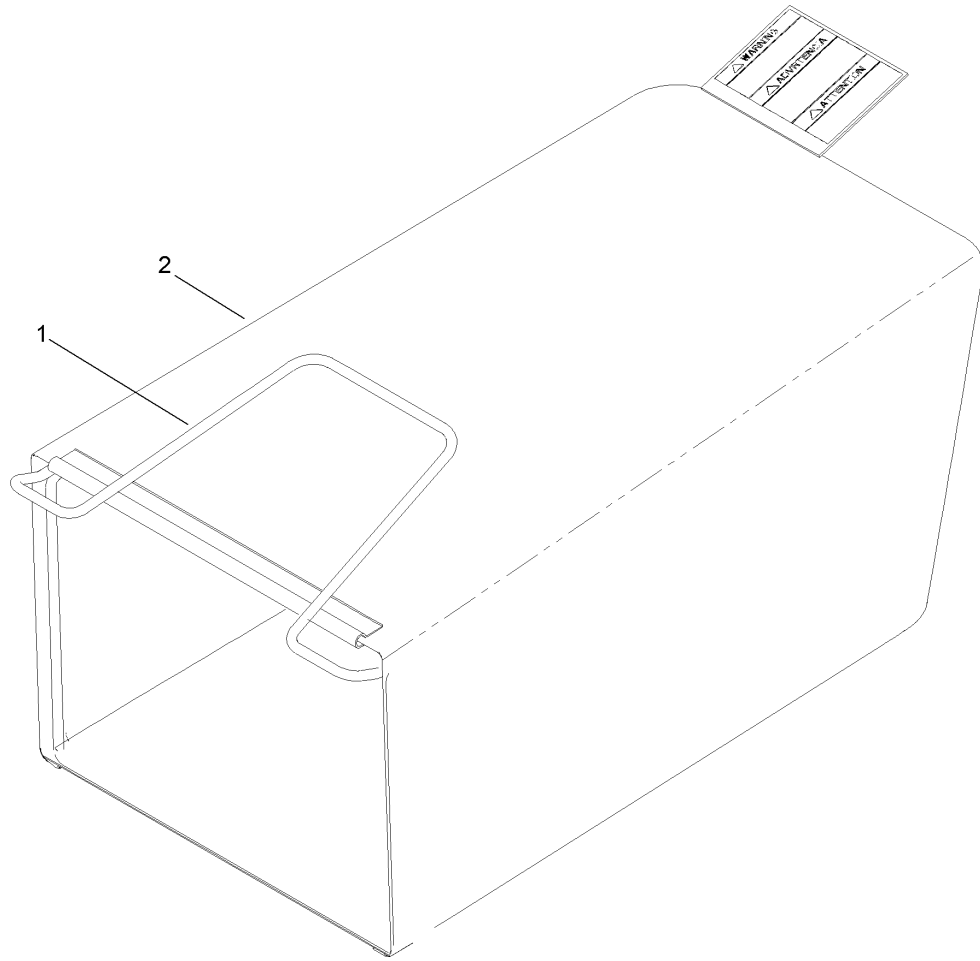

Grass Bag Assembly No. 110-2140

Ref	Part No.	Qty.	Description
1	110-0510-03	1	Frame ASM
2	110-0530	1	Bag-Grass

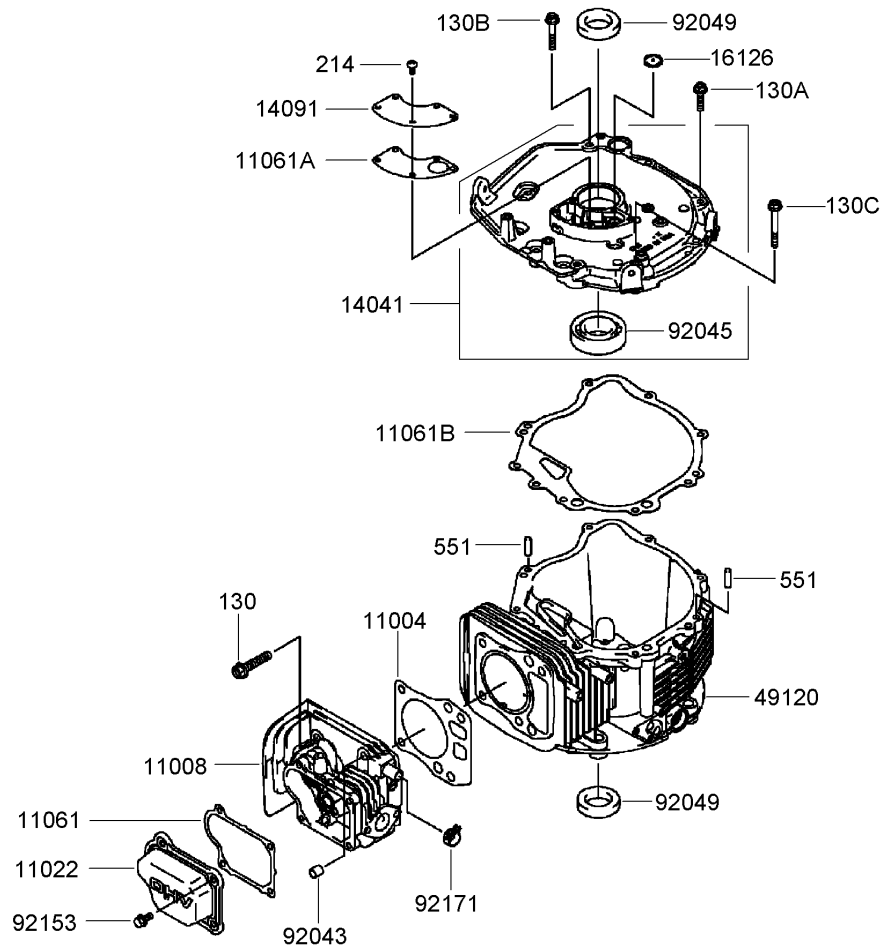

Cylinder and Crankcase Assembly Kawasaki FJ180V-AS30

Ref	Part No.	Qty.	Description
③11004	11004-7020	1	Gasket-Head
③11008	11008-7025	1	Head-Cylinder
③11022	11022-7005	1	Case-Rocker
③11061	11061-7023	1	Gasket-Case, Rocker
③11061A	11061-7031	1	Gasket-Breather
③11061B	11061-7060	1	Gasket-Cover, Crankcase
③14041	14041-7010	1	Cover
③14091	14091-7010	1	Cover-Breather
③16126	16126-7014	1	Valve-Breather
③49120	49120-7082	1	Crankcase
③92043	92043-7001	2	Pin
③92045	92045-1207	1	Bearing-Ball (62/28)
③92049	92049-7008	2	Seal-Oil (28-44-9 T C)
③92153	92153-7043	4	Bolt (6X12)
③92171	92171-7024	1	Clamp
③130	130CA0840	4	Bolt-Flanged (8X40)
③130A	130G0625	7	Bolt-Flanged (6X25)
③130B	130G0635	1	Bolt-Flanged (6X35)
③130C	130G0650	1	Bolt-Flanged,6X50
③214	214B0510	5	Screw-Pan (5X10)
③551	551A0612	2	Pin-Dowel (6X12)

--	--	--	--

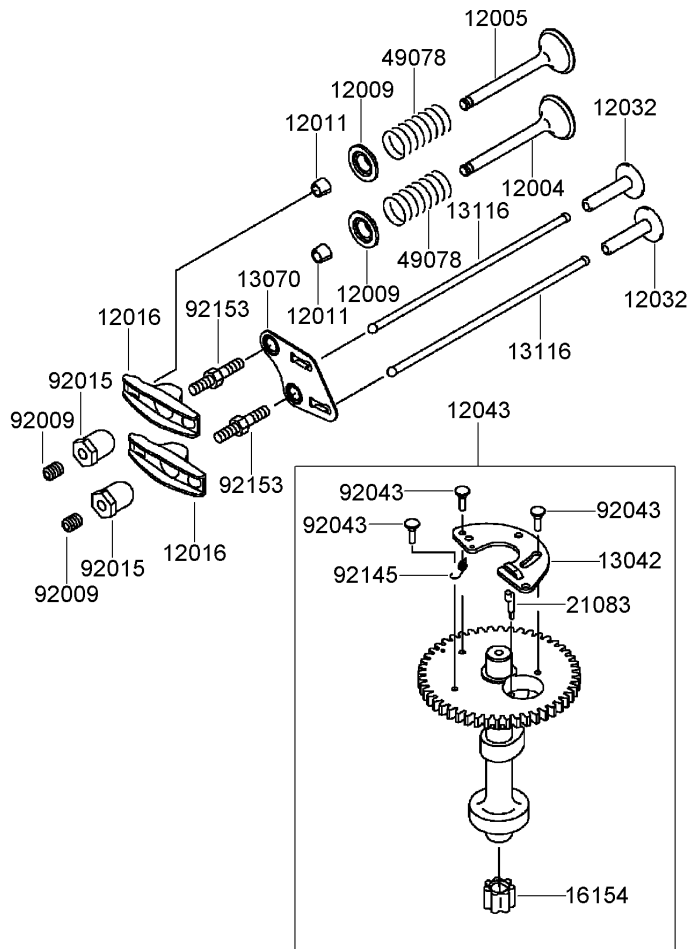

Valve and Camshaft Assembly Kawasaki FJ180V-AS30

Ref	Part No.	Qty.	Description
①	12004	1	Valve-Intake
①	12005	1	Valve-Exhaust
②	12009	2	Retainer-Spring, Valve
④	12011	4	Collet
②	12016	2	Arm-Rocker
②	12032	2	Tappet
①	12043	1	Camshaft Valve ASM
①	13042	1	Weight
①	13070	1	Guide
②	13116	2	Rod-Push
①	16154	1	Rotor-Pump
①	21083	1	Arm
②	49078	2	Spring-Valve, Engine
②	92009	2	Screw
②	92015	2	Nut
③	92043	3	Pin
①	92145	1	Spring
②	92153	2	Bolt

--	--	--	--

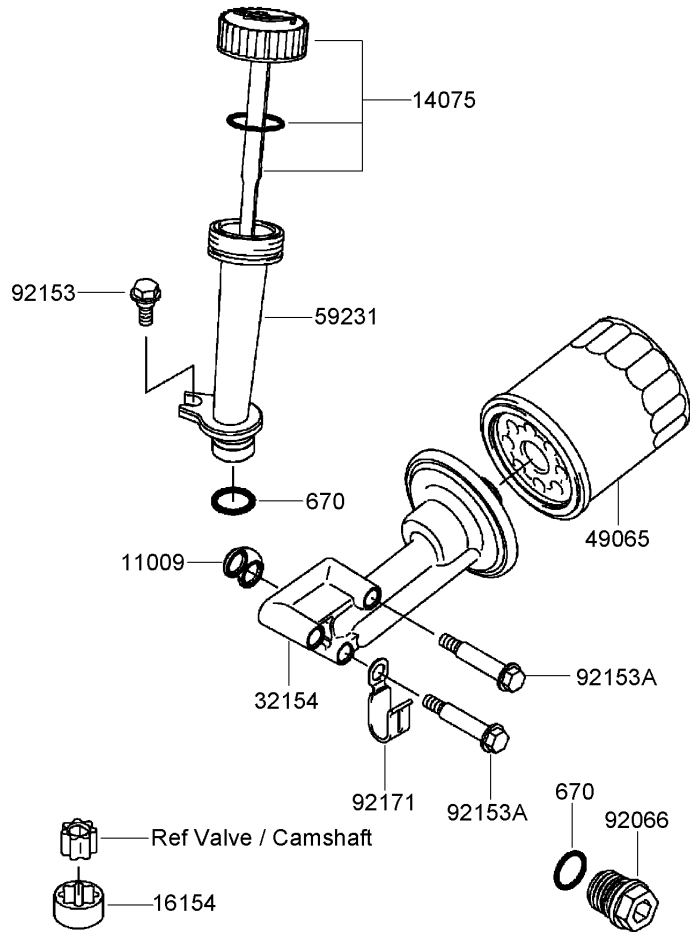

Lubrication Equipment Assembly Kawasaki FJ180V-AS30

Ref	Part No.	Qty.	Description
● 11009	11009-2860	1	Gasket
● 14075	14075-7007	1	Cap ASM
● 16154	16154-7002	1	Rotor-Pump
● 32154	32154-7018	1	Pipe
● 49065	49065-2078	1	Filter-Oil
● 59231	59231-7004	1	Filler
● 92066	92066-7003	1	Plug
● 92153	92153-7007	1	Bolt
● 92153A	92153-7028	3	Bolt
● 92171	92171-7008	1	Clamp
● 670	670D2016	2	O-Ring (16Mm)

--	--	--	--

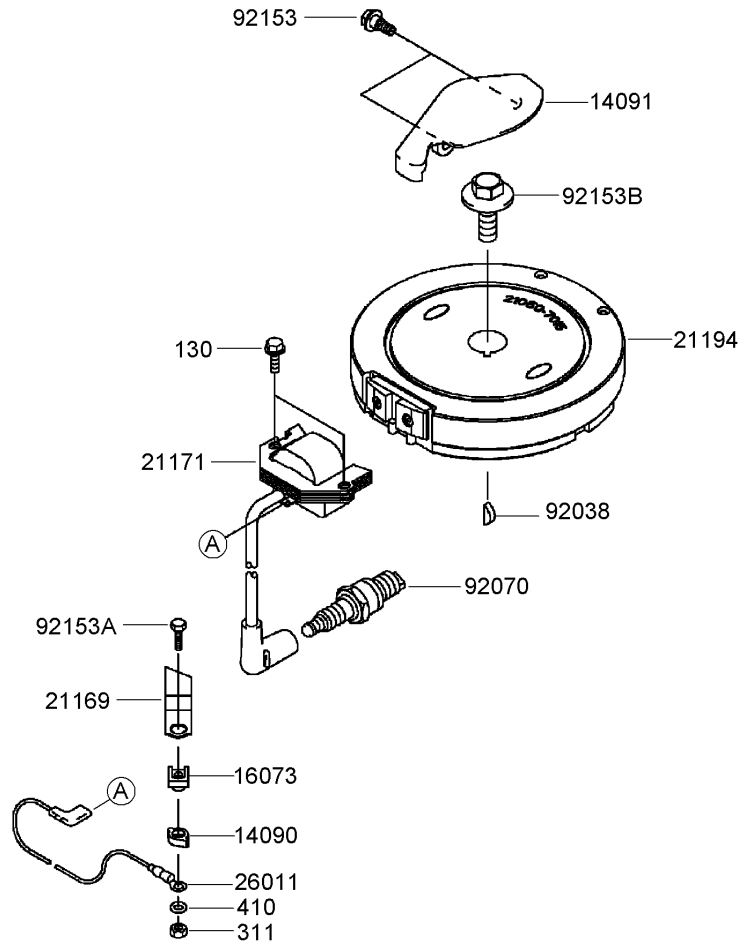

Electric Equipment Assembly Kawasaki FJ180V-AS30

Ref	Part No.	Qty.	Description
● 14090	14090-2108	1	Cover
● 14091	14091-7036	1	Cover
● 16073	16073-2192	1	Insulator
● 21169	21169-2071	1	Terminal
● 21171	21171-7030	1	Ignition Coil ASM
● 21194	21194-7024	1	Flywheel
● 26011	26011-7013	1	Wire-Lead
● 92038	92038-2077	1	Key
● 92070	92070-2088	1	Spark Plug, B P R 5E S (N G K) Solid
● 92153	92153-7007	2	Bolt
● 92153A	92153-7012	1	Bolt (4X16)
● 92153B	92153-7030	1	Bolt (12X30)
● 130	130B0620	2	Bolt-Flanged (6X20)
● 311	311B0400	1	Nut-Hex (4Mm)
● 410	410B0400	1	Washer-Plain, S (4Mm)

--	--	--	--

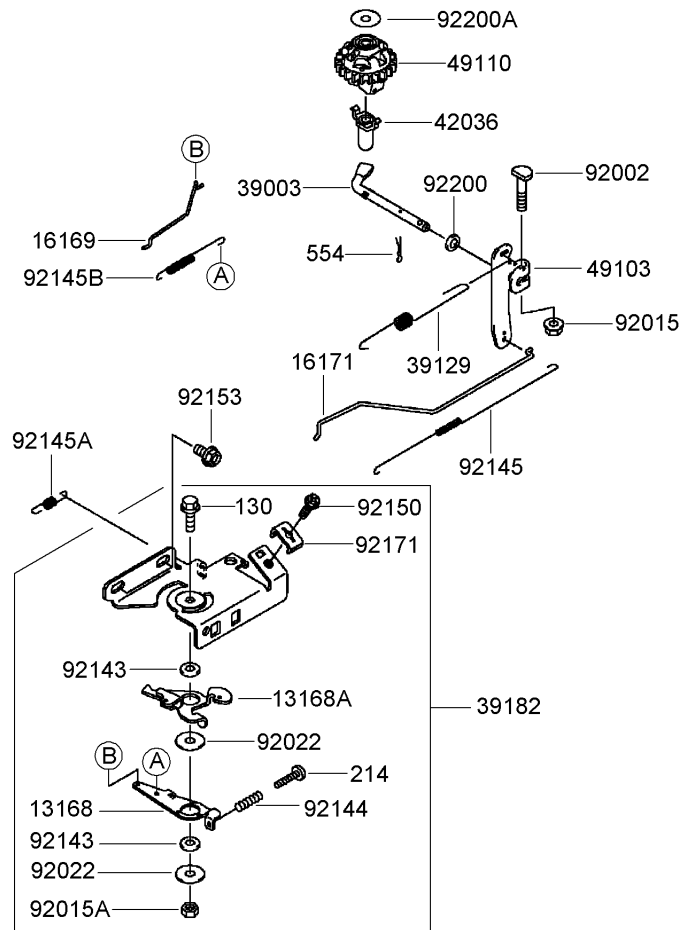

Control Equipment Assembly Kawasaki FJ180V-AS30

Ref	Part No.	Qty.	Description
●13168	13168-7028	1	Lever
●13168A	13168-7032	1	Lever
●16169	16169-7015	1	Link-Choke
●16171	16171-7015	1	Link-Throttle
●39003	39003-7002	1	Arm-Pivot
●39129	39129-7014	1	Spring-Governor
●39182	39182-7007	1	Panel-Assy-Control
●42036	42036-2051	1	Sleeve
●49103	49103-7005	1	Arm-Governor
●49110	49110-7002	1	Governor ASM
●92002	92002-2269	1	Bolt (6X28)
●92015	92015-1193	1	Nut
●92015A	92015-2051	1	Nut
●92022	92022-2372	2	Washer (6X19X1.2)
●92143	92143-2135	2	Collar (6X13X2.3)
●92144	92144-2266	1	Spring
●92145	92145-7025	1	Spring-Throttle
●92145A	92145-7032	1	Spring
●92145B	92145-7043	1	Spring
●92150	92150-2182	1	Bolt (5X18)
●92153	92153-7043	2	Bolt (6X12)
●92171	92171-7016	1	Clamp
●92200	92200-2029	1	Washer (6.5X11.5X2.0)
●92200A	92200-2036	1	Washer (6.2X20X0.5)

Ref	Part No.	Qty.	Description
●130	130B0618	1	Bolt-Flanged
●214	214B0420	1	Screw-Pan +- (4X20)
●554	554A0600	1	Pin-Snap (1.2X21.2)

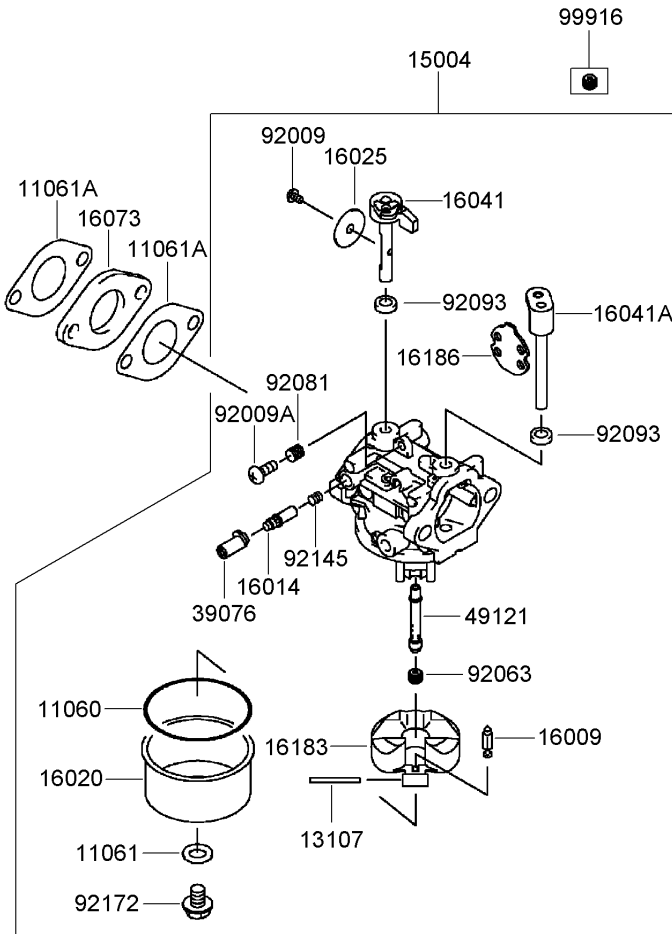

Carburetor Assembly Kawasaki FJ180V-AS30

Ref	Part No.	Qty.	Description
③11060	11060-2190	1	Gasket
③11061	11061-7010	1	Gasket-Screw
③11061A	11061-7015	2	Gasket-Insulator
③13107	13107-7024	1	Shaft
③15004	15004-7010	1	Carburetor ASM
③16009	16009-2136	1	Needle-Jet
③16014	16014-7008	1	Screw-Air, Pilot
③16020	16020-7004	1	Chamber-Float
③16025	16025-7007	1	Valve-Throttle
③16041	16041-7019	1	Shaft-Carburetor
③16041A	16041-7020	1	Shaft-Carburetor
③16073	16073-7006	1	Insulator
③16183	16183-2002	1	Float ASM
③16186	16186-7003	1	Choke Valve ASM
③39076	39076-7001	1	Limiter
③49121	49121-7014	1	Nozzle-Main
③92009	92009-2083	1	Screw
③92009A	92009-2349	1	Screw
③92063	92063-7067	1	Jet-Main (No 70)
③92081	92081-2234	1	Spring
③92093	92093-2100	2	Seal
③92145	92145-7015	1	Spring
③92172	92172-7002	1	Screw
③99916	99916-7007	1	Main Jet K H I Parts Kit

--	--	--	--

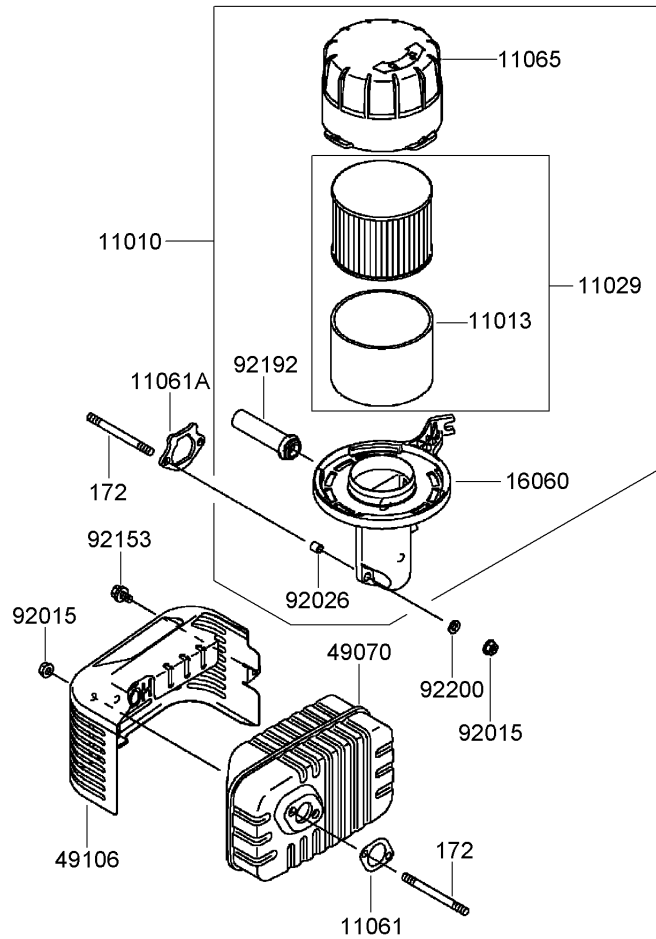

Air Filter and Muffler Assembly Kawasaki FJ180V-AS30

Ref	Part No.	Qty.	Description
①11010	11010-7021	1	Air Filter ASM
①11013	11013-7037	1	Element-Filter, Air
①11029	11029-7023	1	Air Filter Element ASM
①11061	11061-7029	1	Gasket-Muffler
①11061A	11061-7075	1	Gasket-Pipe, Intake
①11065	11065-7018	1	Cap
①16060	16060-7026	1	Pipe-Intake
①49070	49070-7022	1	Muffler
①49106	49106-7021	1	Cover-Muffler
①92015	92015-1193	4	Nut
①92026	92026-7021	2	Spacer
①92153	92153-7023	1	Bolt (6X10)
①92192	92192-7083	1	Tube
①92200	92200-7022	2	Washer
①172	172G0680	4	Bolt-Stud (6X80)

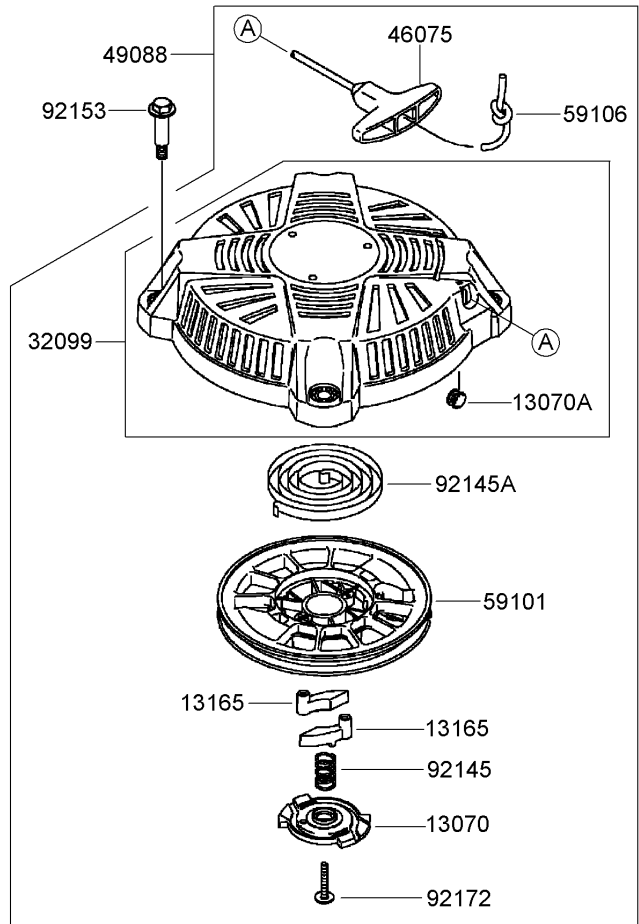

Starter Assembly Kawasaki FJ180V-AS30

Ref	Part No.	Qty.	Description				
● 13070	13070-7014	1	Guide				
● 13070A	13070-7015	1	Guide				
● 13165	13165-7002	2	Pawl-Starter, Recoil				
● 32099	32099-7004	1	Case-Starter, Recoil				
● 46075	46075-7002	1	Grip				
● 49088	49088-7024	1	Starter-Recoil				
● 59101	59101-7002	1	Reel-Starter, Recoil				
● 59106	59106-7006	1	Rope (1500Mm)				
● 92145	92145-7052	1	Spring				
● 92145A	92145-7053	1	Spring				
● 92153	92153-7021	4	Bolt (M6)				
● 92172	92172-7030	1	Screw				

NOTES

NOTES

