



21in Heavy-Duty Recycler[®]/Rear Bagger Lawn Mower

Model No. 22196 - 290000001 and up.

Parts Catalog

Ordering Replacement Parts

To order replacement parts, please supply the part number, the quantity, and the description of each part desired.

Understanding Reference Numbers

Each identified part in an illustration has a reference number. The reference number for a part also appears in the parts list, along with other information about the part.

This catalog uses two special reference number formats, one to indicate parts in a service assembly and another to indicate the quantity of a given part in an illustration.

Service Assembly Reference Numbers

Parts in service assemblies have reference numbers in the form a:b. The a represents the reference number of the entire service assembly and the b represents a sequential number unique to each part within the service assembly.

For example, a wheel assembly might be identified by reference number 6, the tire by 6:1, the valve by 6:2, and the wheel by 6:3. When you order the assembly identified by reference number 6, you receive all parts identified by reference numbers 6:1, 6:2, and 6:3. However, you may also order any part individually. Reference numbers of this type appear in illustrations and in part lists.

Reference Numbers Indicating Quantity

In an illustration, if a reference number indicates more than one part, the reference number has the form nX y. The n represents the quantity of the part, the X is the multiplication symbol, and the y represents the reference number.

For example, in an illustration, the reference number 2X 37 means that two of the parts identified by reference number 37 are indicated.

Contents

Description	Page	Description	Page
Housing, Chute and Wheel Assembly 3	Camshaft Assembly Honda GXV160UH2 19
Housing Assembly No. 98-7146 5	T1AH	
Front Wheel and Tire Assembly No. 100-2870 6	Recoil Starter Assembly Honda GXV160UH2	
Engine and Blade Assembly 7	T1AH 20
Handle Assembly 9	Fan Cover Assembly Honda GXV160UH2	
Control Panel Assembly 10	T1AH 21
Rear Drive and Wheel Assembly 11	Carburetor Assembly Honda GXV160UH2	
Rear Wheel Assembly No. 100-2860 12	T1AH 22
Grass Bag Assembly No. 106-0975 13	Air Cleaner Assembly Honda GXV160UH2	
Cylinder Head Assembly Honda GXV160UH2		T1AH 24
T1AH 14	Muffler Assembly Honda GXV160UH2 T1AH 25
Cylinder Assembly Honda GXV160UH2 T1AH 15	Fuel Tank Assembly Honda GXV160UH2	
Crankshaft and Piston Assembly Honda		T1AH 26
GXV160UH2 T1AH 17	Flywheel Assembly Honda GXV160UH2 T1AH 28
		Control Assembly Honda GXV160UH2 T1AH 29
		Label and Tool Assemblies Honda	
		GXV160UH2 T1AH 30

Part Description Abbreviations

Part descriptions in this catalog may include the following abbreviations.

AR. as required	HYD. hydraulic
ASM. assembly	LH. left hand
BBC. blade brake clutch	NI. nylon insert
CARR. carriage	NPTF. national pipe thread fine
DEG. degrees	PFH. phillips flat head
EXT. external	PPH. phillips pan head
FH. flat head	PPHTF. phillips pan head thread forming
GA. gauge	PRH. phillips round head
HD. heavy-duty	PTH. phillips truss head
HF. hex flange	PTO. power-take-off
HH. hex head	RH. right hand
HHF. hex head flange	ROPS. roll-over protection system
HHFTF. hex head flange thread forming	SFH. slotted fillister head
HJ. hex jam	SHH. slotted hex head
HLH. hex lag head	SHWH. slotted hex washer head
HOC. height-of-cut	SPH. slotted pan head
HSBH. hex socket button head	SQH. square head
HSFH. hex socket flat head	SRH. slotted round head
HSH. hex socket head	STD. standard
HWH. hex washer head	TAP. self tapping
HWHTF. hex washer head thread forming	TTH. torx truss head

Footnotes

- ❶ Not illustrated
- ❷ Not serviced separately
- ❸ Obtain from your local Honda dealer

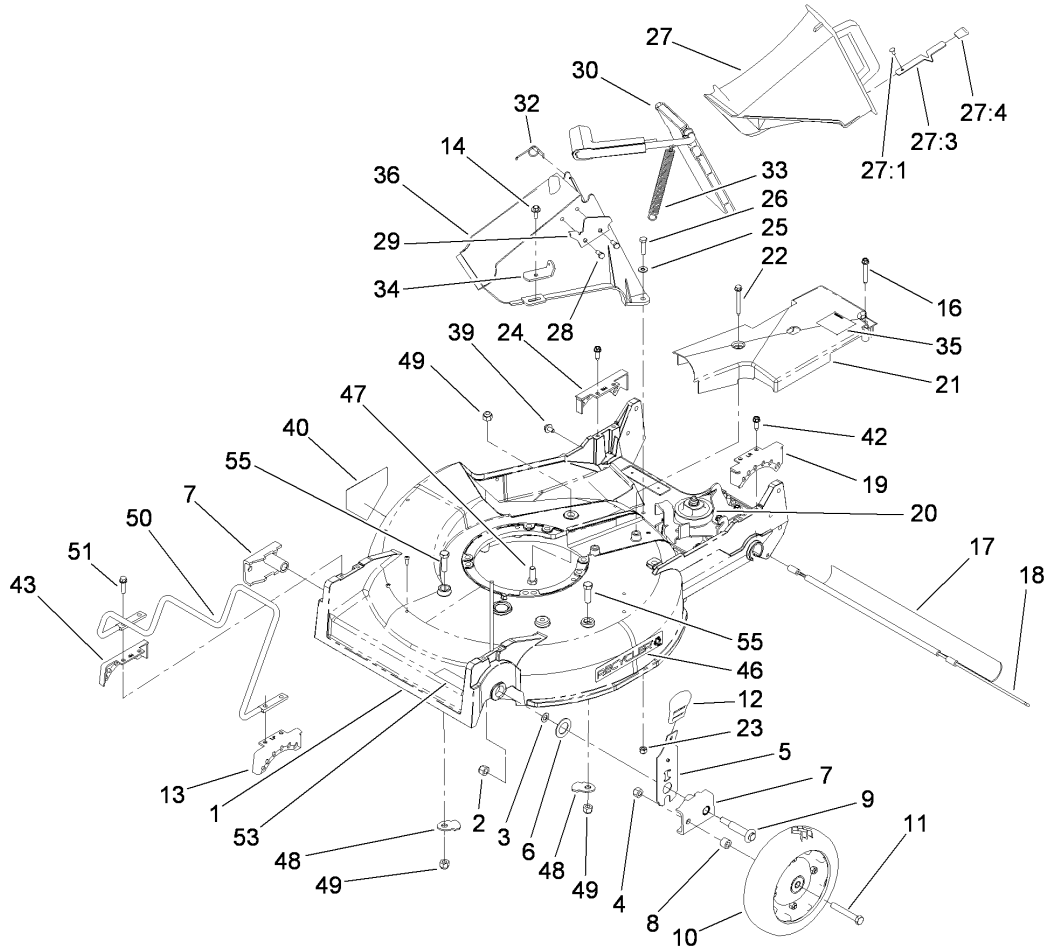

Housing, Chute and Wheel Assembly

Ref	Part No.	Qty.	Description
1	98-7146	1	Housing
2	3296-6	2	Nut-Lock
3	40-1940	2	Washer
4	32152-2	2	Nut-Lock, Cone
5	115-0980	2	Front Spring Arm ASM
6	257-3	2	Washer-Thrust
7	61-8300	2	Arm-Pivot, Front
8	52-2480	2	Spacer-Wheel
9	114-3468	2	Screw-Shoulder
10	100-2870	2	Wheel And Tire ASM
11	323-12	2	Screw-HH
12	110-0549	2	Knob-HOC
13	49-8760	1	Quadrant-Front, LH
14	46-6811	1	Screw-HWH
16	92-1616	1	Screw-HWHTF
17	112-9989	1	Shield-Trailing
18	33-3208	1	Rod-Shield
19	49-8740	1	Quadrant-Rear, LH
20	74-1860	1	Gear Case ASM
21	74-1770	1	Cover-Belt
22	37-7260	1	Screw-HHFTF
23	3296-42	2	Nut-Lock, NI
24	49-8750	1	Quadrant-Rear, RH
25	3256-22	2	Washer-Flat

Ref	Part No.	Qty.	Description
26	321-8	2	Screw-HH
27	77-0500	1	Discharge Plug ASM
27:1	3295-35	1	Rivet-Head, Flat
27:3	76-4640	1	Latch-Plug, Discharge
27:4	76-4650	1	Grip-Latch
28	46-8090	2	Screw-Plastite
29	93-3154	1	Latch-Plate
30	93-7351	1	Discharge Door ASM
32	80-3770	1	Retainer-Door
33	76-4660	1	Spring-Door
34	71-9350	1	Bracket-Spring
35	52-2620	1	Label-Grease
36	82-9152	1	Tunnel-Discharge
39	46-6810	1	Screw And Washer ASM
40	43-8480	1	Decal-Danger
42	49-2040	4	Screw-HWHTF
43	49-8770	1	Quadrant-Front, RH
46	106-0689	1	Decal
47	323-6	1	Screw-HH
48	84-8930	2	Shield-Retainer
49	3296-39	3	Nut-Lock, NI
50	109-7638	1	Guard-Engine
51	32144-86	4	Screw-HWHTF
53	68-7410	1	Decal-Blade

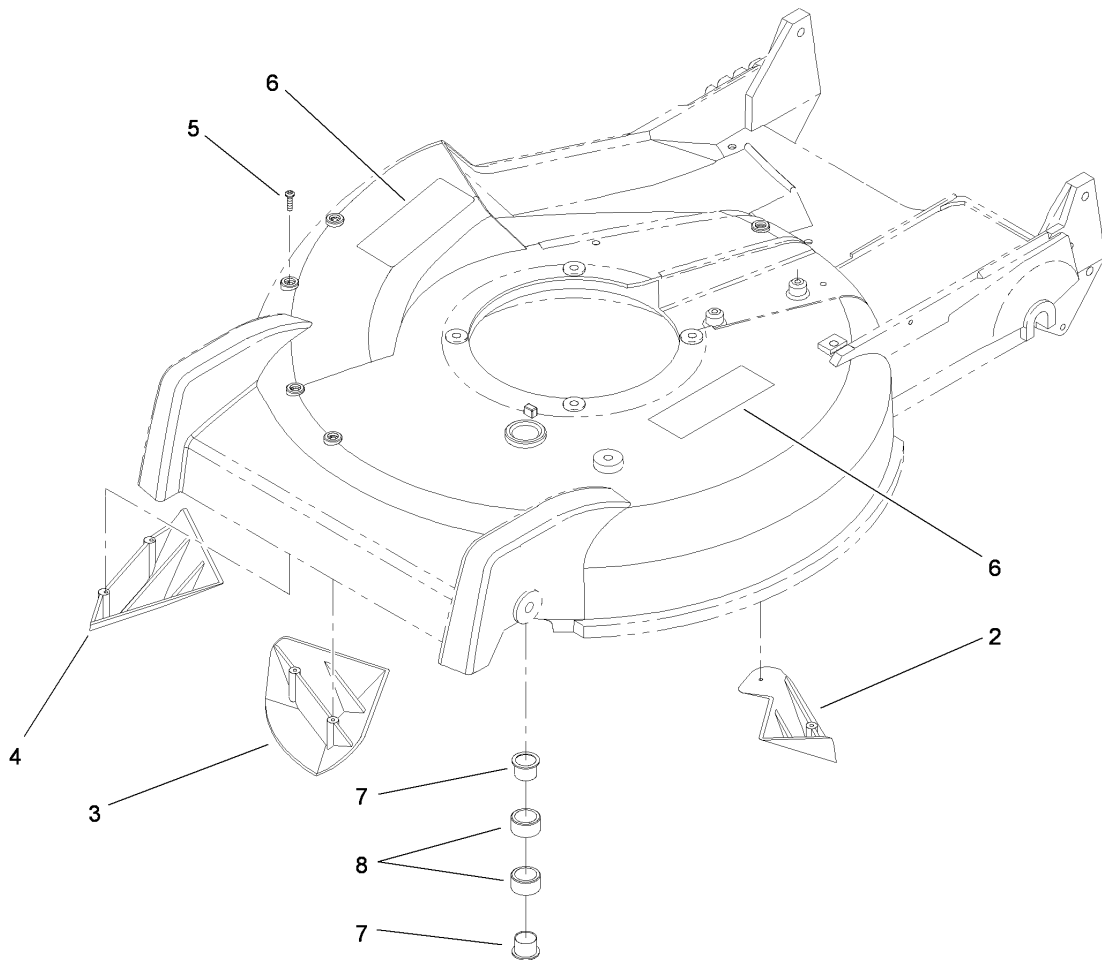

Housing Assembly No. 98-7146

Ref	Part No.	Qty.	Description
2	92-1750	1	Kicker-Rear, Sp
3	92-1720	1	Kicker-Front
4	92-1730	1	Kicker-RH
5	32144-111	6	Screw-PPH
6	110-4978	2	Decal-Danger
7	2410-72	2	Caplug
8	68-9780	2	Bearing

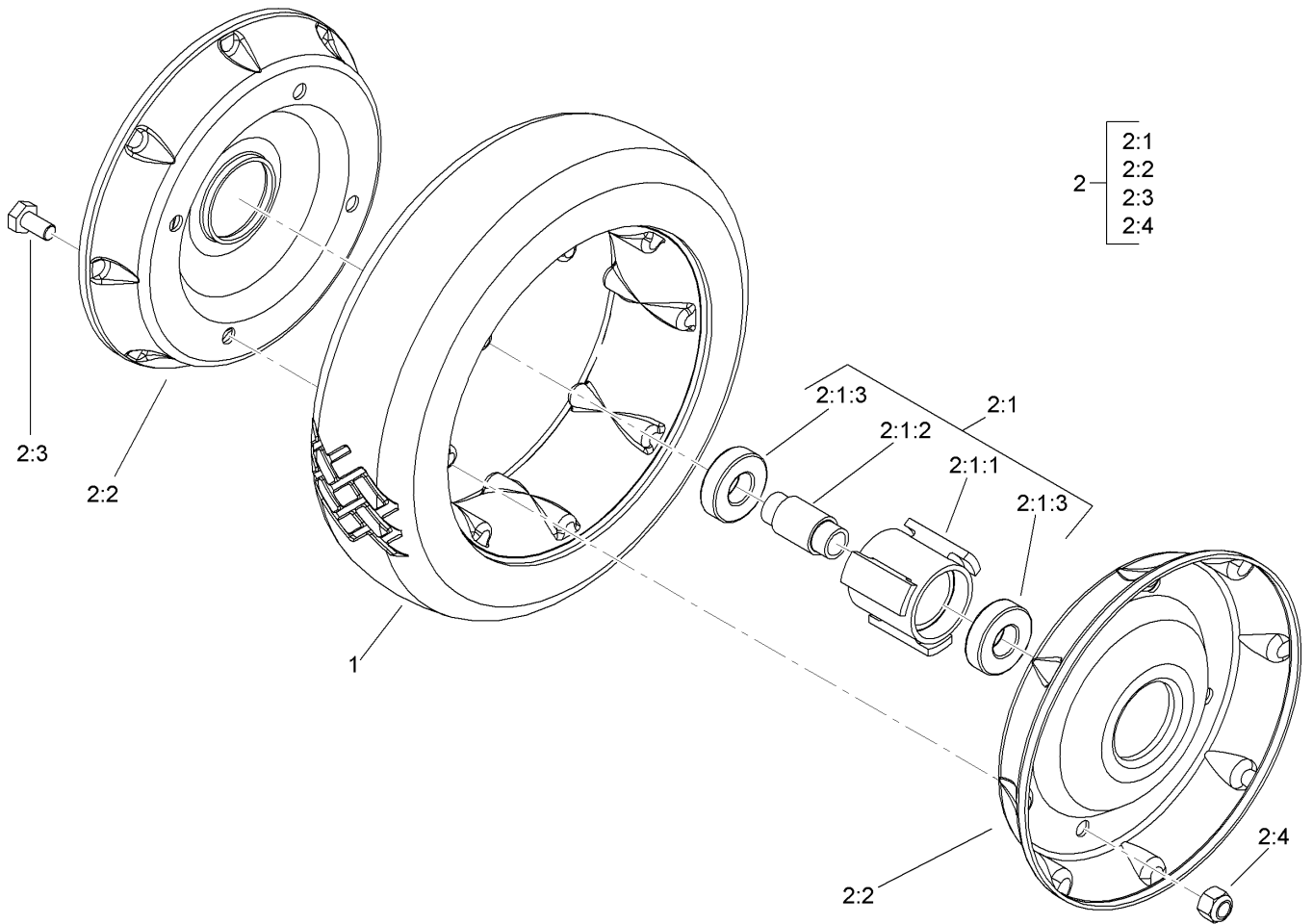

Front Wheel and Tire Assembly No. 100-2870

Ref	Part No.	Qty.	Description
1	53-7740	1	Tire
2		1	Wheel ASM
2:1		1	Hub And Bearing ASM
2:1:1	52-2410	1	Hub-Bearing
2:1:2	52-2440	1	Spacer-Bearing
2:1:3	52-2450	2	Bearing-Wheel
2:2	53-7780-06	2	Plate-Wheel, Half
2:3	321-2	4	Screw-HH
2:4	3296-42	4	Nut-Lock, NI

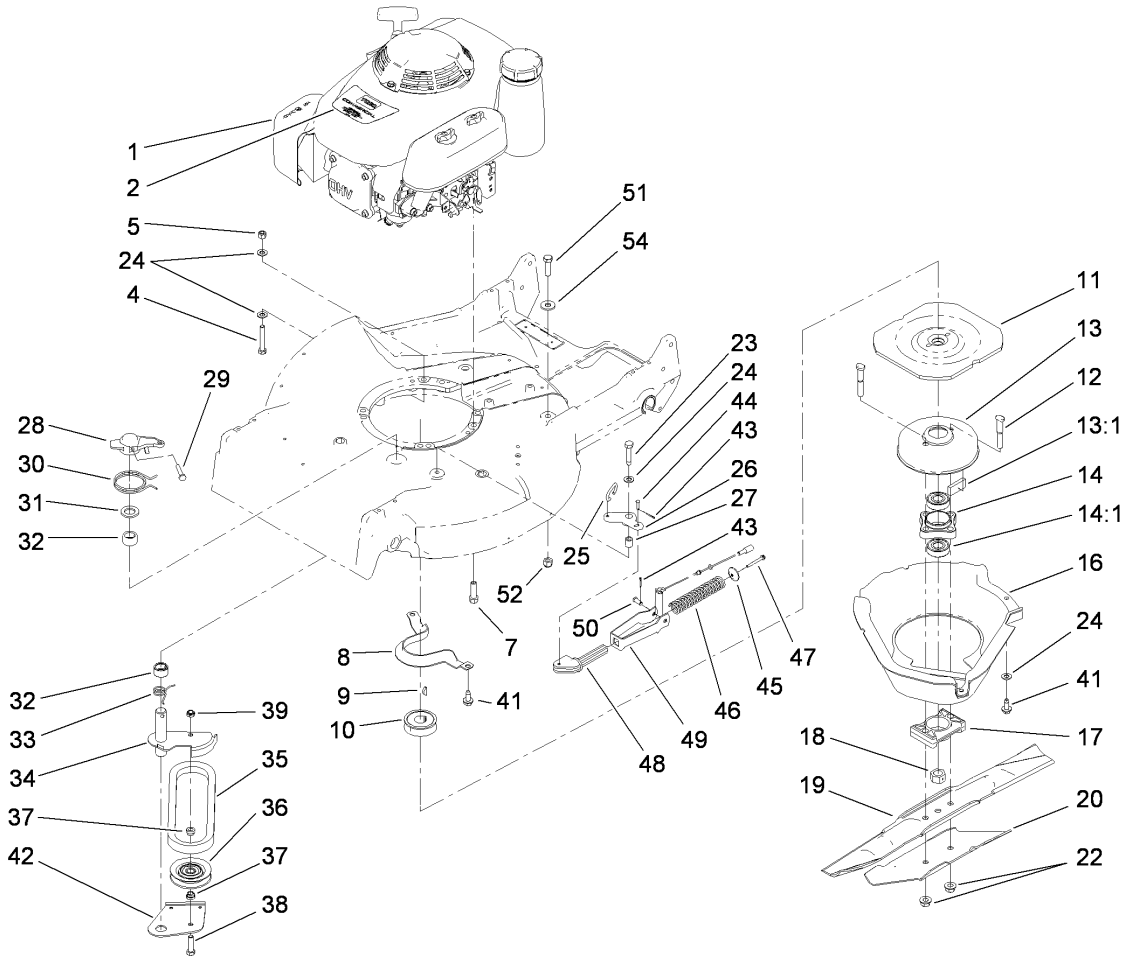

Engine and Blade Assembly

Ref	Part No.	Qty.	Description
1		1	Engine-Honda Gxv160Uh2 T1Ah
2	112-9974	1	Decal-Engine, Honda
4	322-11	1	Screw-HH
5	3296-29	1	Nut-Lock, NI
7	103-2678	3	Screw-Shoulder
8	66-0570-03	1	Bracket-Guide, Belt
9	3257-17	1	Key-Woodruff
10	56-6180	1	Pulley-Driver
11	56-6160-03	1	Flywheel-BBC
12	42-3190	2	Bolt-Blade
13	94-9431	1	Brake Drum ASM
13:1	52-3480	2	Dampener-Vibration
14	42-6890	1	Hub ASM
14:1	100-1048	2	Bearing-Ball
16	46-5693	1	Shield
17	107-4275	1	Spacer-Blade
18	603164	1	Nut-Blade
19	91-2256-03	1	Blade-21 Inch
20	91-2255-03	1	Stiffener-Blade
22	54-9190	2	Nut-Lock
23	32104-107	1	Screw-HH
24	3256-23	5	Washer-Flat
25	49-2810	1	Link-Control
26	49-7960	1	Bellcrank

Ref	Part No.	Qty.	Description
27	49-7950	1	Sleeve-Bellcrank
28	49-2820	1	Lever
29	32104-96	1	Screw-HH
30	49-7970	1	Spring-Torsion
31	70-1160	1	Washer
32	68-9780	2	Bearing
33	85-6880	1	Spring-Torsion
34	84-9130	1	Arm-Idler
35	42-0884	1	V-Belt
36	46-5650	1	Pulley-Idler
37	46-5631	2	Spacer-Pulley, Idler
38	322-6	1	Screw-HH
39	3296-47	1	Nut-Lock, NI
41	32144-70	3	Screw-HWHTF
42	84-9180	1	Brake Plate ASM
43	3272-1	2	Pin-Cotter
44	84-9050	1	Pin-Spring
45	65-5280	1	Retainer-Spring
46	84-9100	1	Spring
47	46-7040	1	Screw-HWHTF
48	106-0842	1	Guide-Spring
49	107-4087-03	1	Bracket-Spring
50	84-9040	1	Pin-Cable
51	323-7	1	Screw-HH

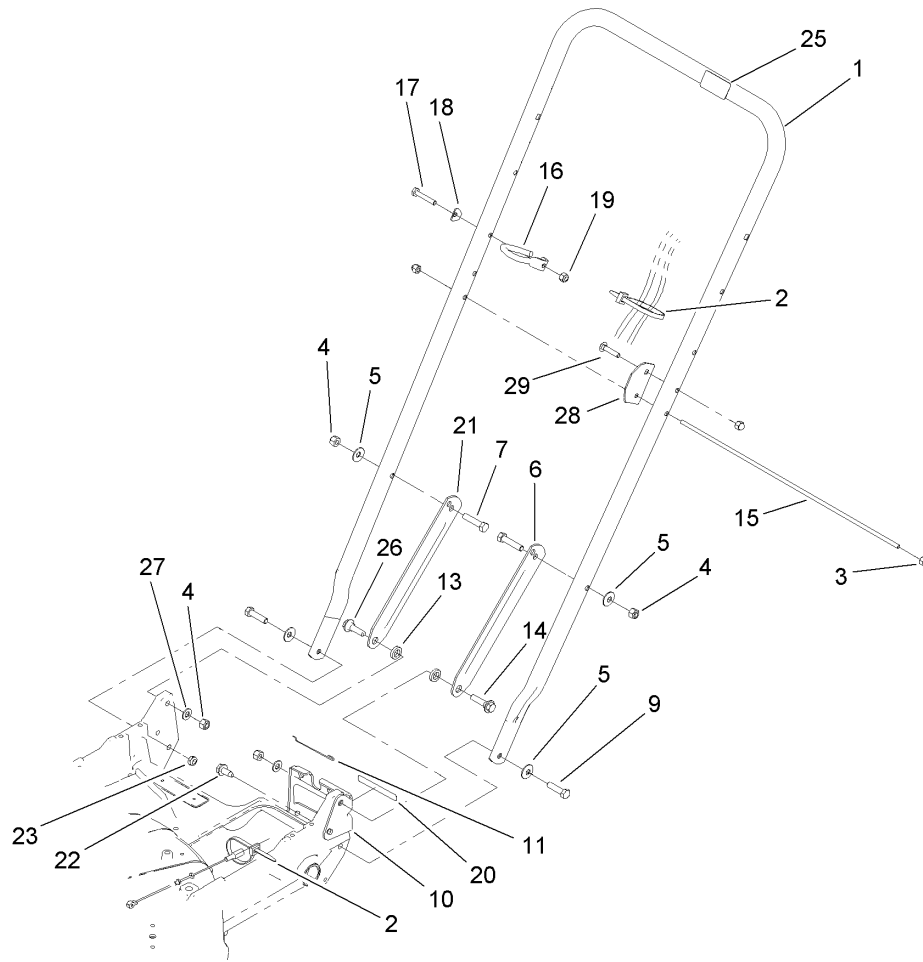

Handle Assembly

Ref	Part No.	Qty.	Description
1	98-2385-03	1	Handle
2	3290-378	3	Tie-Cable
3	32111-7	3	Nut-Cap
4	3296-29	4	Nut-Lock, NI
5	3290-456	4	Washer-Belleville
6	100-3298-03	1	Latch-Handle, LH
7	322-7	2	Screw-HH
9	322-6	2	Screw-HH
10	74-1741	1	Bracket-Adjustment, Traction
11	46-7030	1	Retainer-Cable
13	3-3287	2	Spacer-Latch, Handle
14	27-7210	1	Screw-Shoulder
15	48-2810	1	Rod-Support, Bag
16	46-8081	1	Guide-Rope
17	321-9	1	Screw-HH
18	3-7501	1	Washer
19	3296-42	1	Nut-Lock, NI
20	74-1970	1	Decal-Position, Gear
21	100-3297-03	1	Latch-Handle, RH
22	32144-70	1	Screw-HWHTF
23	3296-47	2	Nut-Lock, NI
25	98-4387	1	Decal-Protection, Ear
26	27-7211	1	Screw-Shoulder
27	3256-23	2	Washer-Flat

Ref	Part No.	Qty.	Description
28	104-1326	1	Plate-Aligning, Bag
29	3229-3	1	Screw-CARR

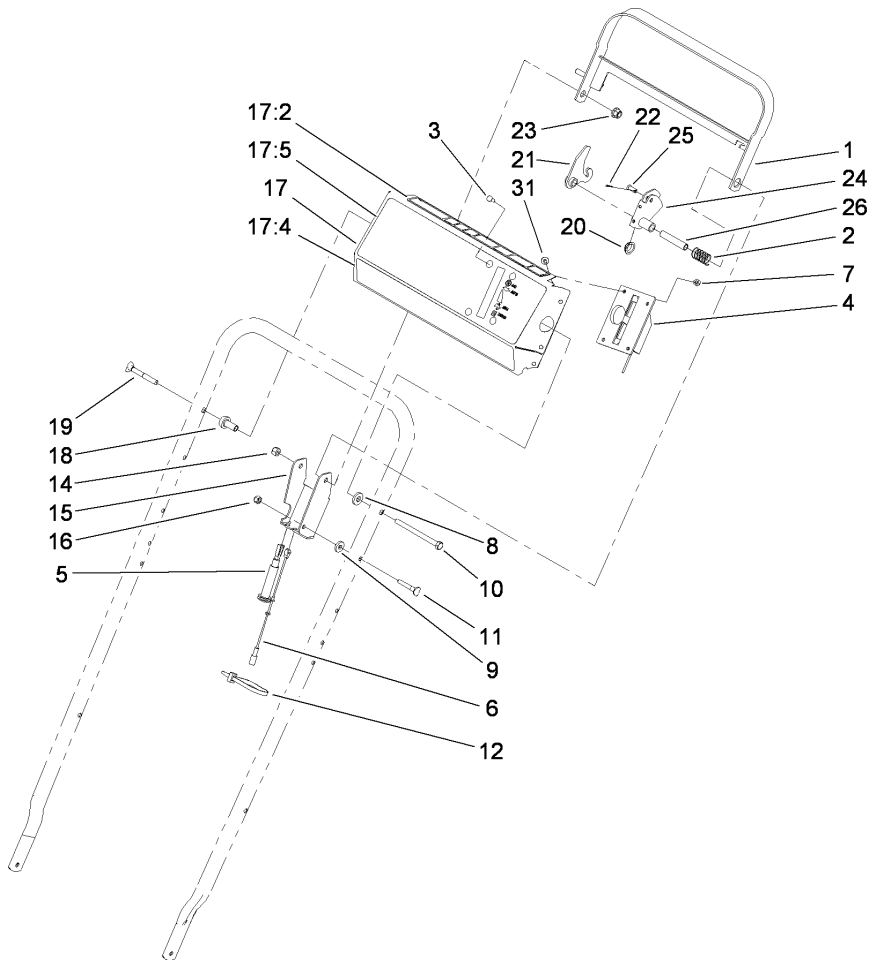

Control Panel Assembly

Ref	Part No.	Qty.	Description
1	84-8940-03	1	Bar-Control
2	85-6750	1	Spring-Control
3	3250-12	4	Screw-PPH
4	114-3488	1	Control-Throttle
5	84-9120	1	Cable-Traction
6	84-9110	1	Cable-Clutch
7	3296-2	4	Nut-Lock NI
8	71-9310	1	Spacer
9	71-9320	1	Spacer
10	322-19	1	Screw-HH
11	46-6430	1	Screw-Handle
12	3290-378	1	Tie-Cable
14	3296-29	1	Nut-Lock, NI
15	92-1778-03	1	Bracket-Control
16	3296-42	1	Nut-Lock, NI
17	14-7709	1	Panel ASM
17:2	104-8582	1	Decal-Panel, Danger
17:4	106-0771	1	Decal-Panel
17:5	107-4098	1	Decal-Panel
18	49-1631	1	Spacer-Support
19	17-9427	1	Screw
20	86-9320	1	Bushing-Flange
21	84-9000	1	Lever-Traction
22	3272-1	1	Pin-Cotter

Ref	Part No.	Qty.	Description
23	3296-58	1	Nut-Lock, NI
24	84-8990	1	Lever-BBC
25	84-9040	1	Pin-Cable
26	84-9030	1	Spacer-Bracket, Control
31	32104-76	6	Screw

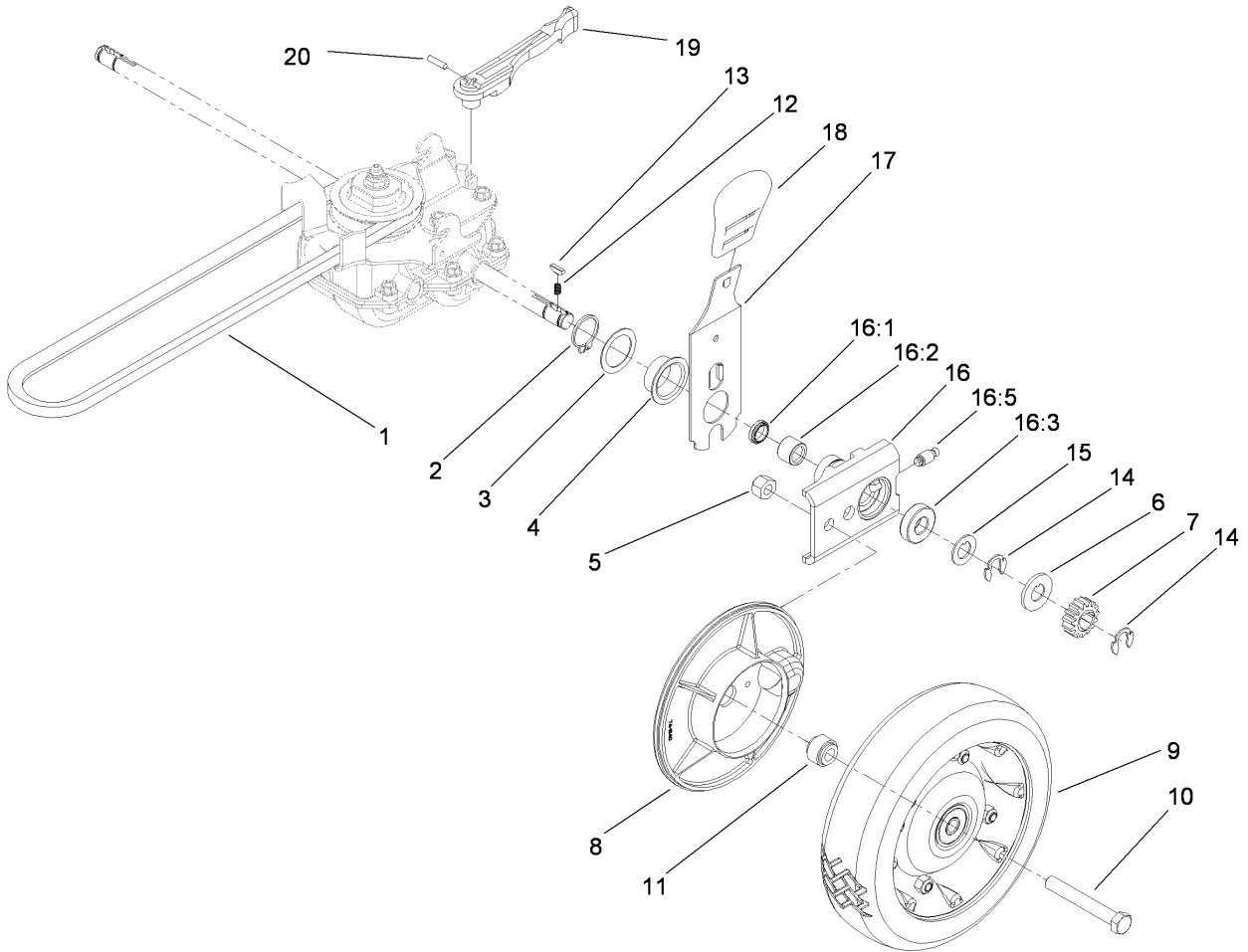

Rear Drive and Wheel Assembly

Ref	Part No.	Qty.	Description
1	36-8070	1	V-Belt
2	32151-36	2	Ring-Retaining
3	74-1810	2	Washer
4	48-2170	2	Cap-End
5	32152-2	2	Nut-Lock, Cone
6	62-3830	2	Washer-Thrust, Outer
7	39-9160	2	Gear-Pinion
8	74-1640	2	Cover-Wheel
9	100-2860	2	Wheel And Tire ASM
10	323-13	2	Screw-HH
11	74-1650	2	Spacer-Cover, Wheel
12	39-9650	2	Spring-Compression
13	612066	2	Key
14	32151-68	4	Ring-Retaining
15	49-7700	2	Washer-Thrust, Outer
16	74-1851	2	Pivot Arm ASM
16:1	47-6730	1	Seal-Oil
16:2	48-2060	1	Bearing-Roller
16:3	52-2450	1	Bearing-Wheel
16:5	92-6316	1	Zerk
17	115-0981	2	Rear Spring Arm ASM
18	110-0549	2	Knob-HOC
19	74-1960	1	Lever-Shift
20	32121-99	1	Pin-Coil

Ref	Part No.	Qty.	Description
●99	106-0975	1	Grass Bag ASM

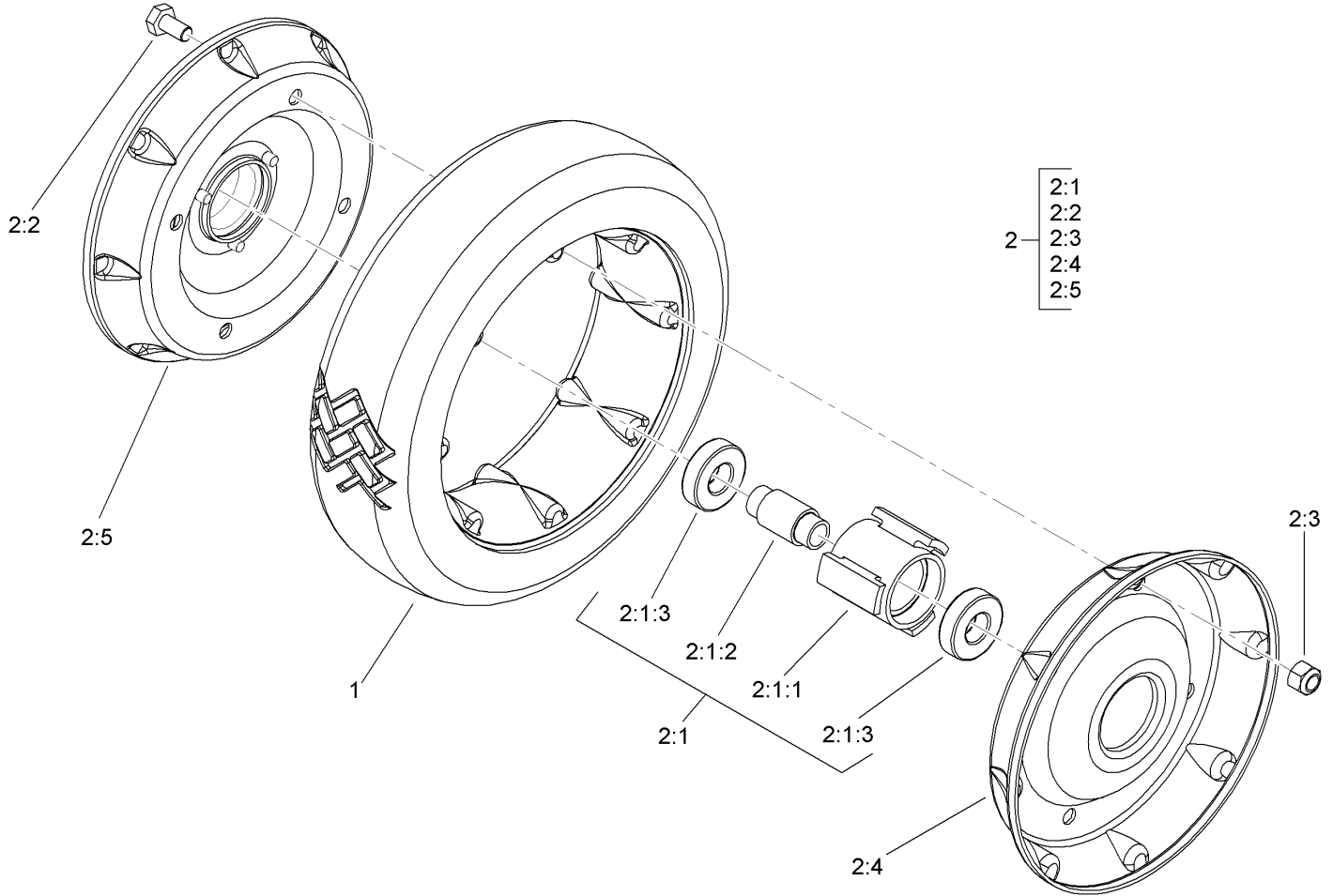

Rear Wheel Assembly No. 100-2860

Ref	Part No.	Qty.	Description
1	53-7740	1	Tire
2		1	Wheel ASM
2:1		1	Hub And Bearing ASM
2:1:1	52-2410	1	Hub-Bearing
2:1:2	52-2440	1	Spacer-Bearing
2:1:3	52-2450	2	Bearing-Wheel
2:2	321-2	4	Screw-HH
2:3	3296-42	4	Nut-Lock, NI
2:4	53-7780-06	1	Plate-Wheel, Half
2:5	92-4957-06	1	Wheel Half And Gear ASM

Ref	Part No.	Qty.	Description

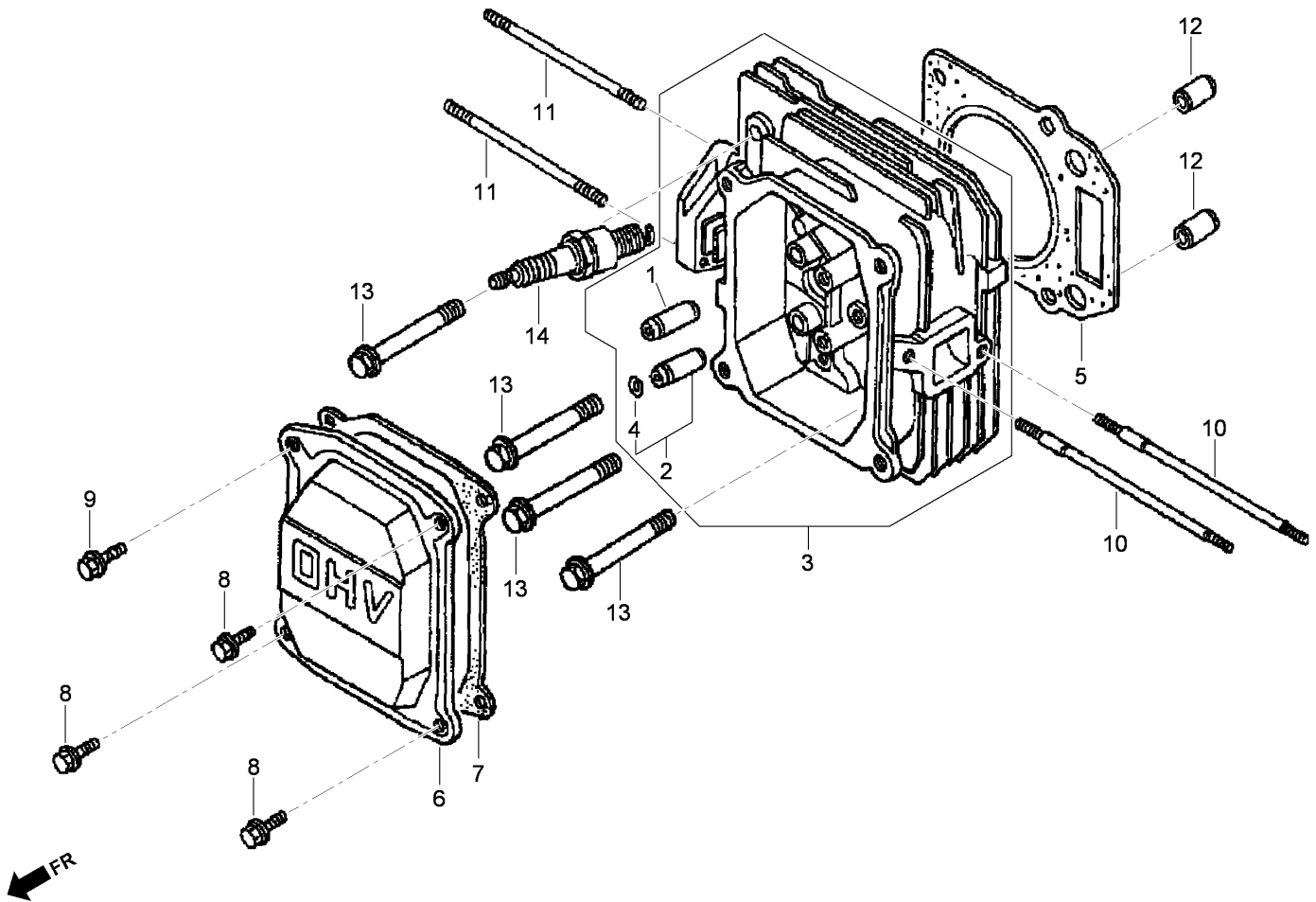

Cylinder Head Assembly Honda GXV160UH2 T1AH

Ref	Part No.	Qty.	Description
❶	12204-ZE1-306	1	Guide-Valve (O S)
❷	12205-ZE1-315	1	Guide-Valve, Exhaust (O S)
❸	12200-ZE7-405	1	Head-Cylinder
❹	12216-ZE5-300	1	Clip-Guide, Valve
❺	12251-ZE7-000	1	Gasket-Head, Cylinder
❻	12311-ZG9-800	1	Cover-Head
❼	12391-ZE7-M10	1	Gasket-Cover, Cylinder Head
❸	90013-883-000	3	Bolt-Flange (6X12) (C T200) (Engine Serial No. Up To 1020657)
❸	90014-952-000	3	Bolt-Flange (6X14) (C T200) (Engine Serial No. From 1020658)
❹	90014-952-000	1	Bolt-Flange (6X14) (C T200)
❷	90043-ZE6-000	2	Bolt-Stud (6X109)
❷	90048-ZC3-000	2	Bolt-Stud (6X85)
❷	94301-10160	2	Pin-Dowel (10X16)

Ref	Part No.	Qty.	Description
❷	95701-08050-00	4	Bolt-Flange (8X50)
❷	98079-54846	1	Spark Plug (B P R4E S) (N G K)
❷	98079-54855	1	Spark Plug (W14E P R-U) (Denso)
❷	98079-55846	1	Spark Plug (B P R 5E S) (N G K)
❷	98079-55855	1	Spark Plug (W16E P R-U) (Denso)
❷	98079-56846	1	Spark Plug (B P R 6E S) (N G K)
❷	98079-56855	1	Spark Plug (W20E P R-U) (Denso)

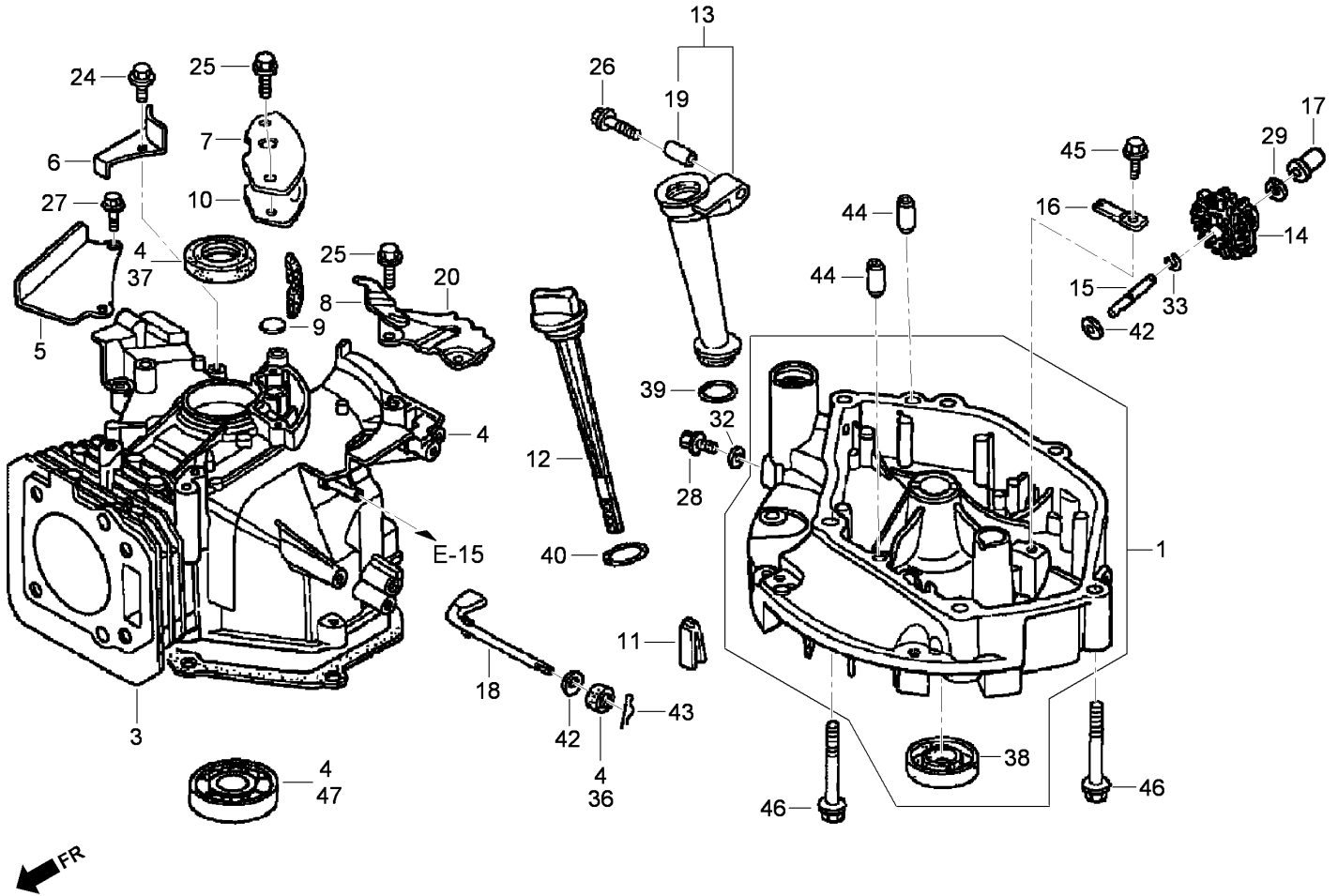

Cylinder Assembly Honda GXV160UH2 T1AH

Ref	Part No.	Qty.	Description
1	11300-Z1V-406	1	Oil Pan ASM
3	11381-ZE7-M10	1	Gasket-Pan, Oil
4	12000-Z2J-405	1	Cylinder ASM
5	12125-Z1V-000	1	Plate-Guide
6	12126-Z1V-000	1	Plate-Guide (A)
7	12355-Z1V-000	1	Cover-Breather
8	12367-883-003	1	Filter-Breather
9	12372-ZE7-000	1	Valve-Breather
10	12373-ZE7-000	1	Gasket-Cover, Breather
11	15335-ZE7-000	1	Rubber-Return, Oil
12	15620-ZE6-810	1	Dipstick-Oil
13	15630-ZE6-810	1	Extension-Filler, Oil (106 Mm)
14	16510-ZE6-000	1	Governor ASM

Ref	Part No.	Qty.	Description
15	16515-ZE6-010	1	Shaft-Holder, Governor
16	16525-ZE6-010	1	Plate-Holder, Governor Shaft
17	16531-Z1T-000	1	Slider-Governor
18	16541-ZE7-000	1	Shaft-Arm, Governor
19	17240-ZE6-000	1	Collar-Extension
20	17560-Z1V-000	1	Stay-Tank
24	90013-883-000	1	Bolt-Flange (6X12) (C T200)
25	90014-952-000	4	Bolt-Flange (6X14) (C T200)
26	90017-883-000	1	Bolt-Flange (6X32)
27	90022-888-010	2	Bolt-Flange (6X20) (C T200)
28	90131-ZE1-000	1	Bolt-Plug, Drain
29	90451-ZE1-000	1	Washer-Thrust (6Mm)
32	90601-ZE1-000	1	Washer-Plug, Drain (102Mm)

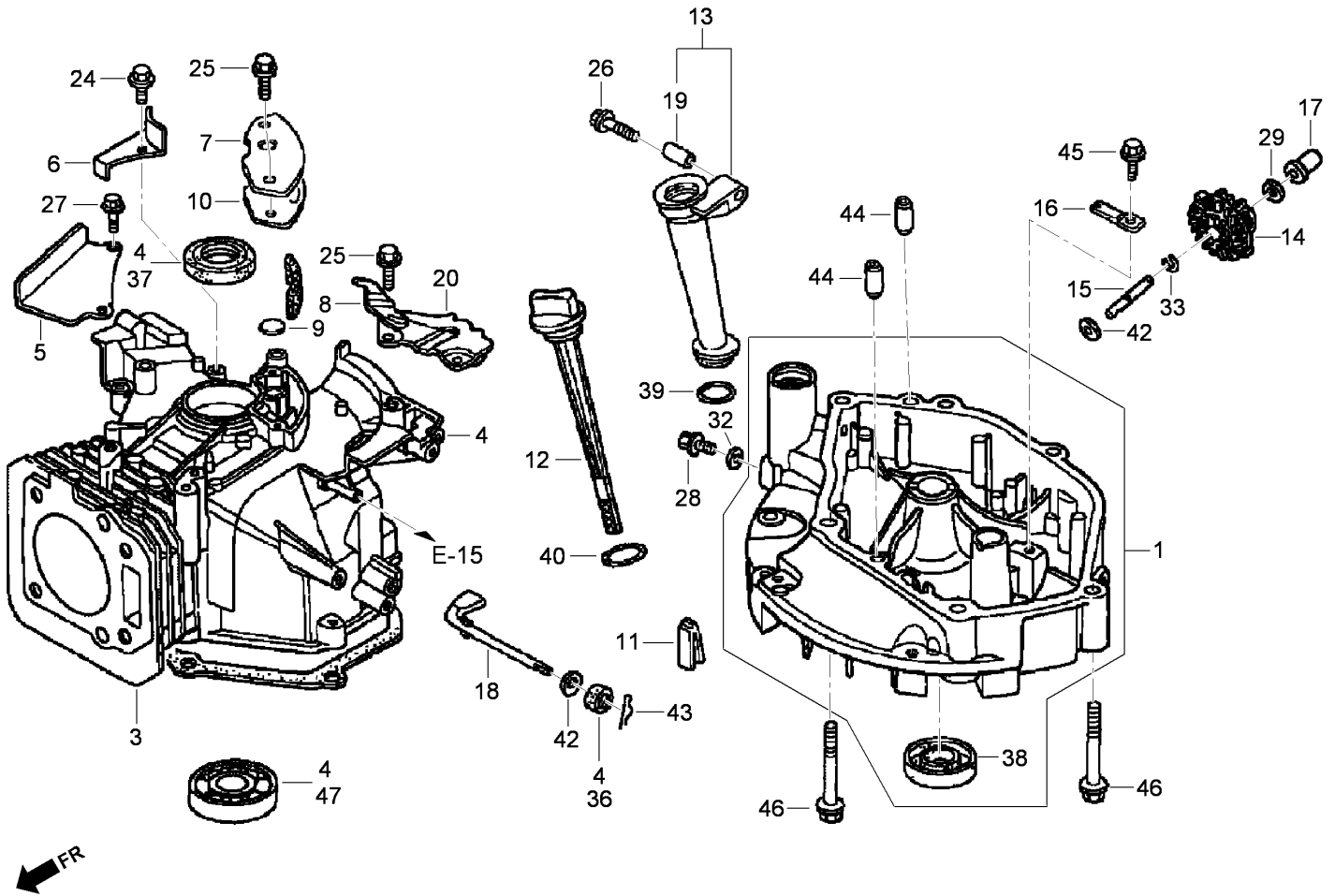

Cylinder Assembly Honda GXV160UH2 T1AH (continued)

Ref	Part No.	Qty.	Description
33	90602-ZE1-000	1	Clip-Holder, Governor
36	91231-Z1V-003	1	Seal-Oil (6X11X4)
37	91251-Z1V-003	1	Seal-Oil (25X38X7)
38	91252-Z1V-003	1	Seal-Oil (25.4X40X7)
39	91301-Z1V-003	1	O-Ring (22.1X2.2)
40	91302-Z1V-003	1	O-Ring (25.5X3)
42	94101-06800	2	Washer-Plain (6Mm)
43	94251-08000	1	Pin-Lock (8Mm)
44	94301-08140	2	Pin-Dowel (8X14)
45	95701-06012-08	1	Bolt-Flange (6X12)
46	95701-08050-00	6	Bolt-Flange (8X50)
47	96100-62050-00	1	Bearing-Ball, Radial (6205)

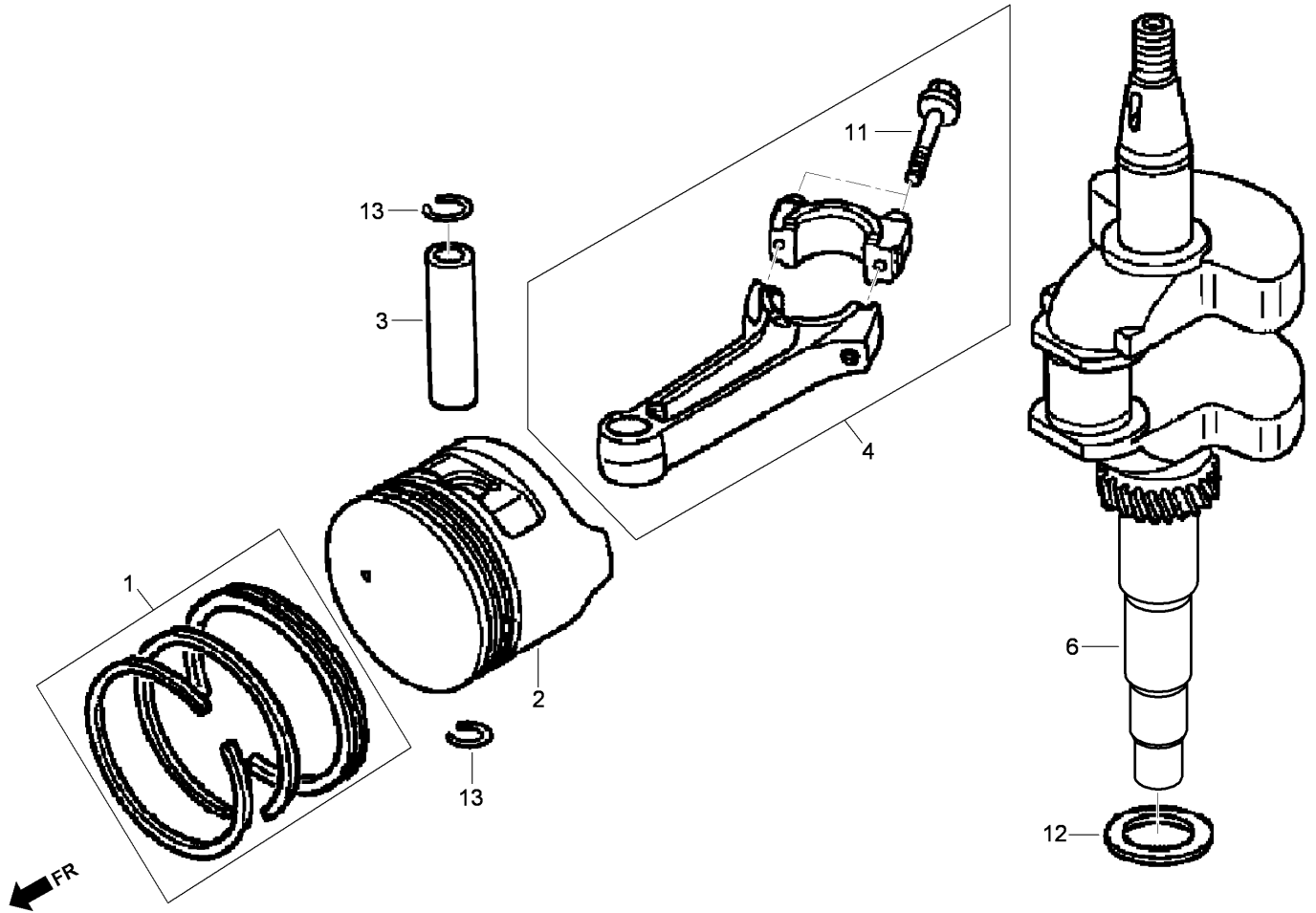

Crankshaft and Piston Assembly Honda GXV160UH2 T1AH

Ref	Part No.	Qty.	Description
❶	13010-ZL0-003	1	Piston Ring Set (STD) (Teikoku) (Engine Serial No. Up To 1036455)
❶	13010-ZL0-004	1	Piston Ring Set (STD) (Nippon) (Engine Serial No. Up To 1036455)
❶	13010-Z4K-004	1	Piston Ring Set (STD) (Teikoku) (Engine Serial No. From 1036456)
❶	13010-Z4P-003	1	Piston Ring Set (STD) (Riken) (Engine Serial No. From 1036456)
❶	13011-ZL0-003	1	Piston Ring Set (O S 0.25) (Teikoku) (Engine Serial No. Up To 1036455)
❶	13011-ZL0-004	1	Piston Ring Set (O S 0.25) (Nippon) (Engine Serial No. Up To 1036455)
❶	13011-Z4K-004	1	Piston Ring Set (O S 0.25) (Teikoku) (Engine Serial No. From 1036456)
❶	13011-Z4P-003	1	Piston Ring Set (O S 0.25) (Riken) (Engine Serial No. From 1036456)
❶	13012-ZL0-003	1	Piston Ring Set (O S 0.50) (Teikoku) (Engine Serial No. Up To 1036455)
❶	13012-ZL0-004	1	Piston Ring Set (O S 0.50) (Nippon) (Engine Serial No. Up To 1036455)

Ref	Part No.	Qty.	Description
❶	13012-Z4K-004	1	Piston Ring Set (O S 0.50) (Teikoku) (Engine Serial No. From 1036456)
❶	13012-Z4P-003	1	Piston Ring Set (O S 0.50) (Riken) (Engine Serial No. From 1036456)
❶	13013-ZL0-003	1	Piston Ring Set (0.75) (Teikoku) (Engine Serial No. Up To 1036455)
❶	13013-ZL0-004	1	Piston Ring Set (0.75) (Nippon) (Engine Serial No. Up To 1036455)
❶	13013-Z4K-004	1	Piston Ring Set (0.75) (Teikoku) (Engine Serial No. From 1036456)
❶	13013-Z4P-003	1	Piston Ring Set (0.75) (Riken) (Engine Serial No. From 1036456)
❷	13101-ZH8-010	1	Piston (STD) (Engine Serial No. Up To 1036455)
❷	13101-Z1T-010	1	Piston (STD) (Jialing-Honda) (Engine Serial No. From 1036456)
❷	13102-ZE7-020	1	Piston (O S 0.25) (Engine Serial No. Up To 1036455)
❷	13102-ZH8-020	1	Piston (O S 0.25) (Engine Serial No. From 1036456)
❷	13103-ZE7-020	1	Piston (O S 0.50) (Engine Serial No. Up To 1036455)
❷	13103-ZH8-020	1	Piston (O S 0.50) (Engine Serial No. From 1036456)

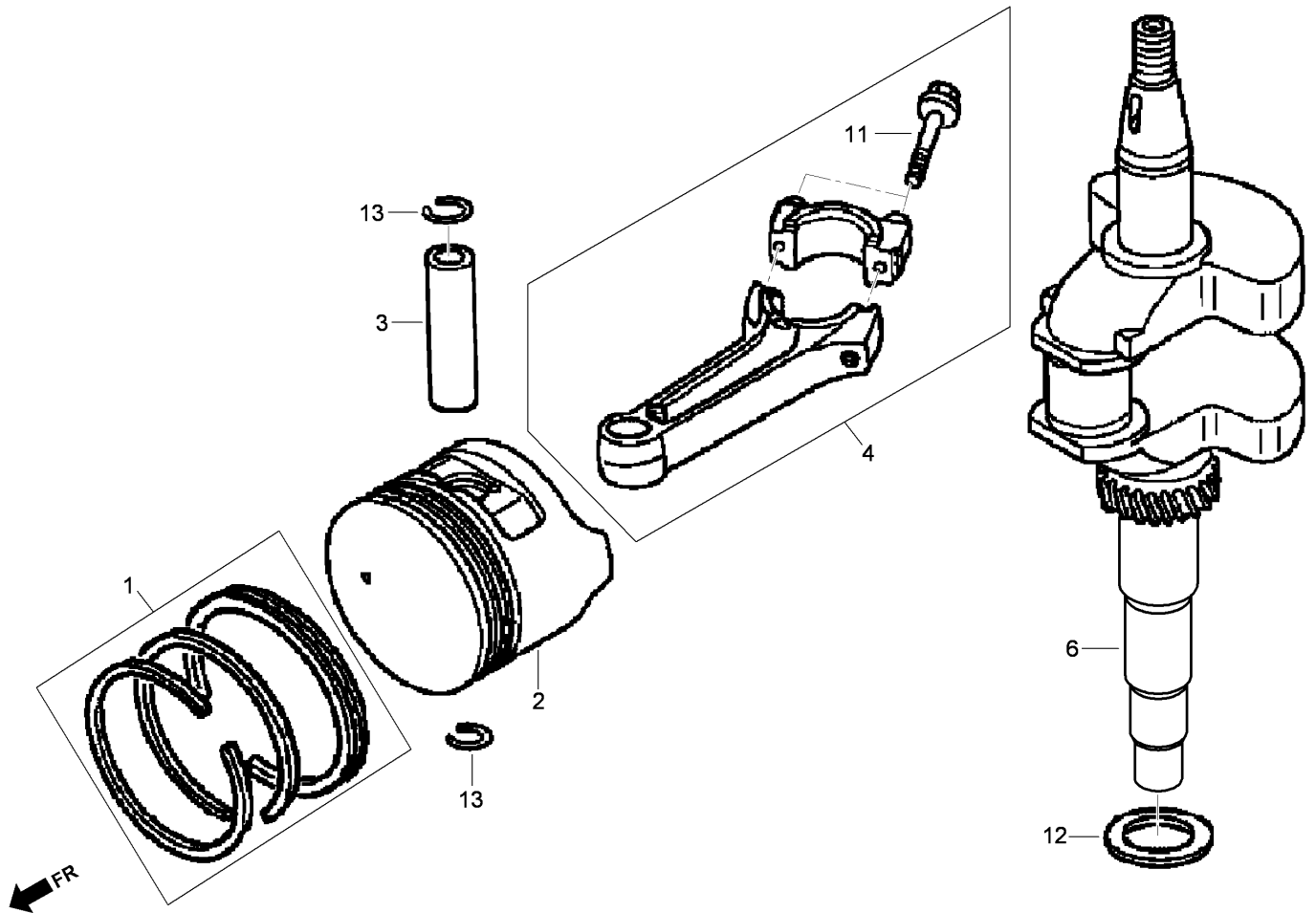

Crankshaft and Piston Assembly Honda GXV160UH2 T1AH (continued)

Ref	Part No.	Qty.	Description
②	13104-ZE7-020	1	Piston (0.75) (Engine Serial No. Up To 1036455)
②	13104-ZH8-020	1	Piston (0.75) (Engine Serial No. From 1036456)
③	13111-Z1T-000	1	Pin-Piston
④	13200-Z1V-000	1	Connecting Rod ASM
⑥	13310-ZE7-V20	1	Crankshaft
⑪	90001-ZE1-000	2	Bolt-Rod, Connecting
⑫	90401-ZE7-W00	1	Washer-Thrust (25.6 Mm)
⑬	90551-ZE1-000	2	Clip-Pin, Piston (18 Mm)

--	--	--	--

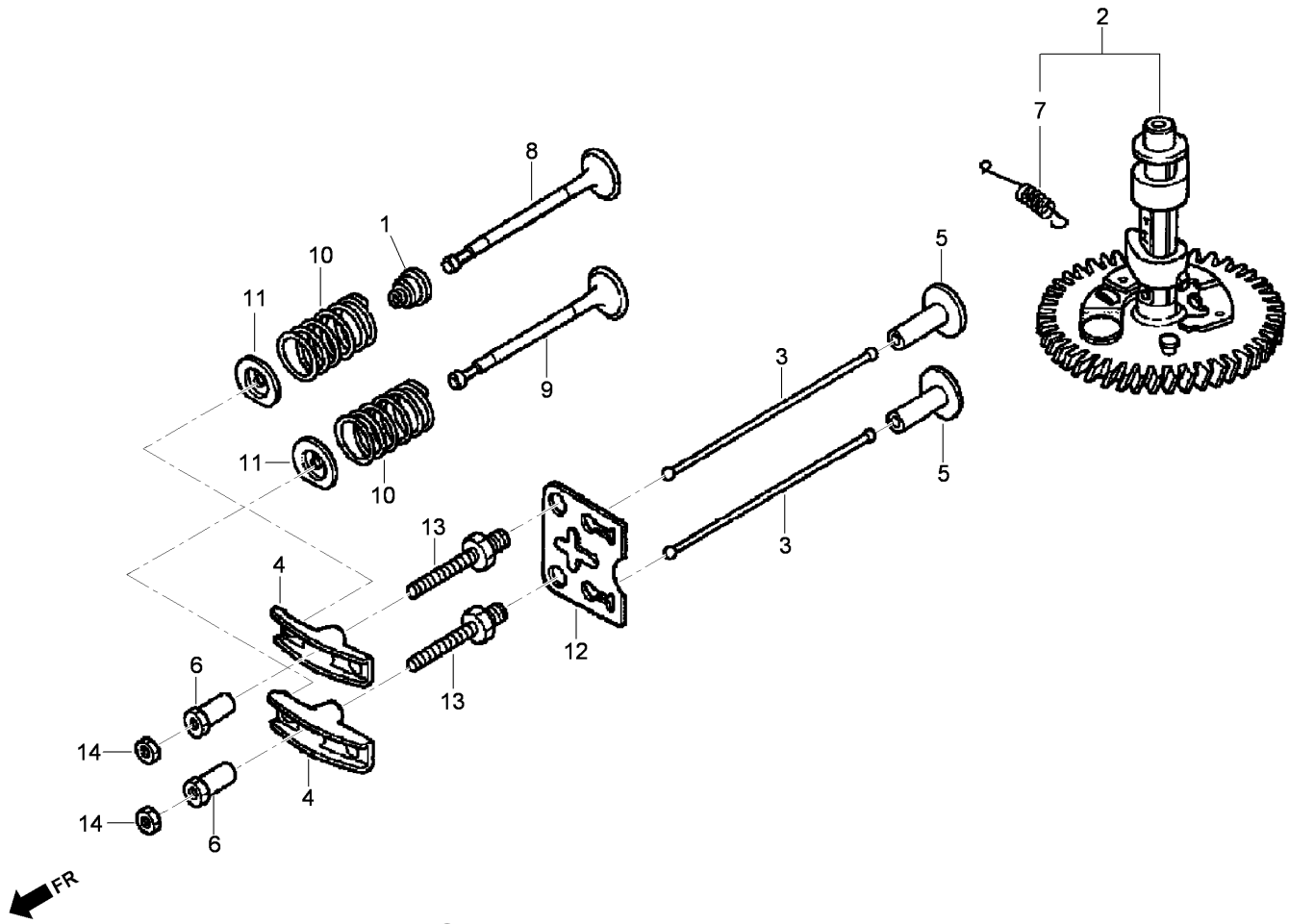

Camshaft Assembly Honda GXV160UH2 T1AH

Ref	Part No.	Qty.	Description
1	12209-ZE6-003	1	Seal-Stem, Valve
2	14100-ZE7-000	1	Camshaft ASM
3	14410-ZE1-010	2	Rod-Push
4	14431-ZE1-000	2	Arm-Rocker, Valve
5	14441-ZE1-010	2	Lifter-Valve
6	14451-ZE1-013	2	Pivot-Arm, Rocker
7	14568-ZE1-000	1	Spring-Return, Weight
8	14711-ZF1-000	1	Valve-Intake
9	14721-ZE7-000	1	Valve-Exhaust
10	14751-ZE1-000	2	Spring-Valve
11	14771-ZE1-000	2	Retainer-Spring, Valve (Intake)
12	14791-ZE1-010	1	Plate-Guide, Push Rod
13	90012-ZE0-010	2	Bolt-Pivot (8 Mm)

Ref	Part No.	Qty.	Description
14	90206-ZE1-000	2	Nut-Adjusting, Pivot

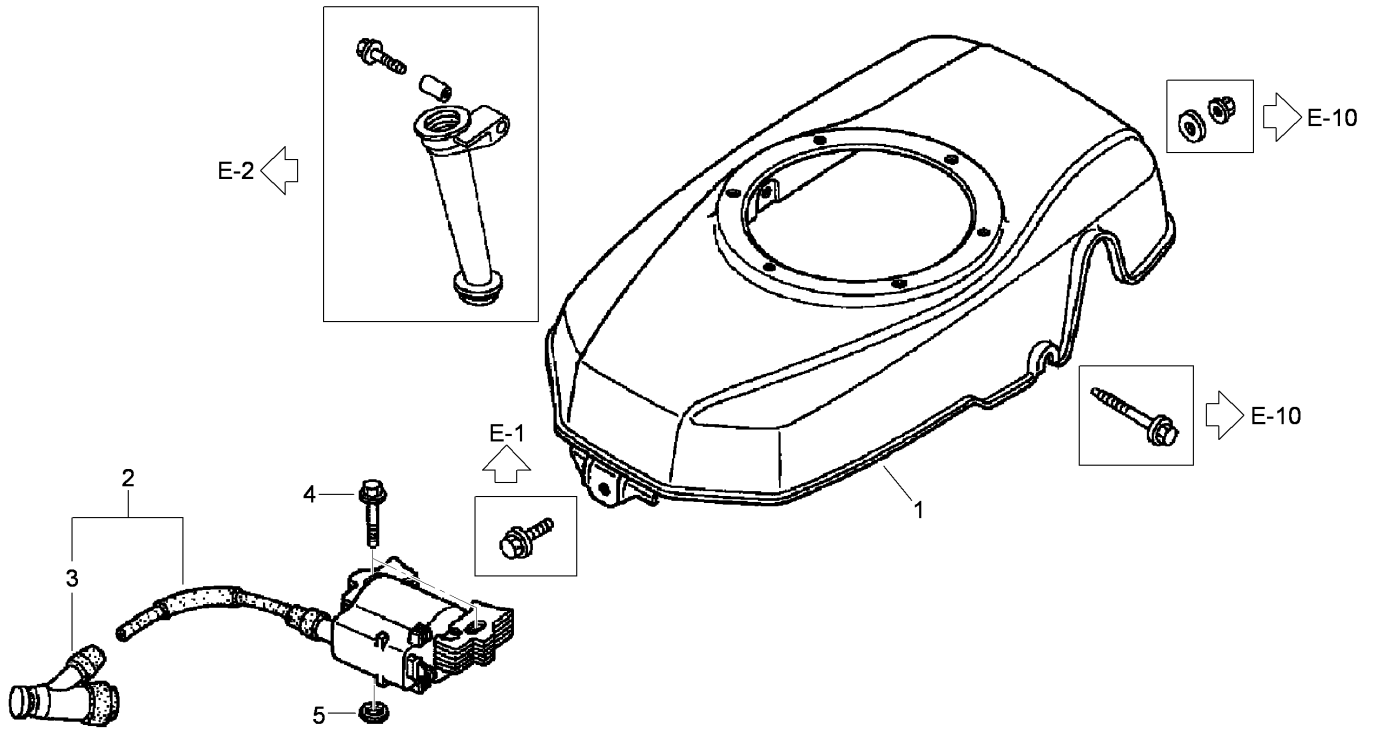

Fan Cover Assembly Honda GXV160UH2 T1AH

Ref	Part No.	Qty.	Description				
❶	19610-Z1V-000ZB	1	Cover-Fan (N H1) (Black)				
❷	30500-Z1V-003	1	Ignition Coil ASM				
❷	30500-Z1V-013	1	Ignition Coil ASM				
❸	30700-Z1V-003	1	Noise Suppressor Cap ASM				
❹	90015-883-000	2	Bolt-Flange (6X28)				
❺	90581-Z1V-000	2	Washer-Plain (6 Mm)				

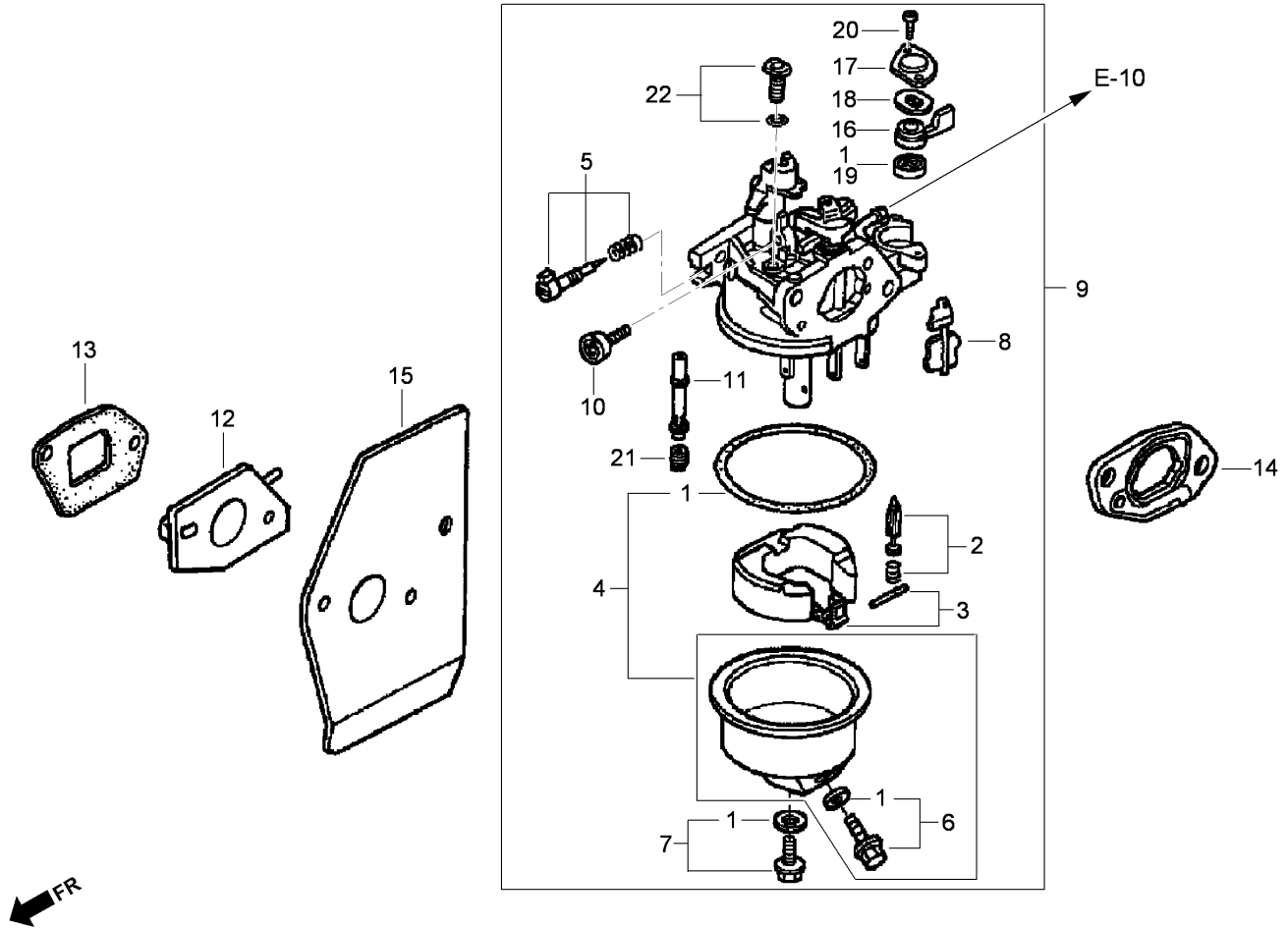

Carburetor Assembly Honda GXV160UH2 T1AH

Ref	Part No.	Qty.	Description
❶	16010-ZE0-025	1	Gasket Set
❷	16011-ZE0-005	1	Float Valve Set
❸	16013-ZE0-005	1	Float Set (Carburetor No. Be66J A)
❸	16013-Z0S-B01	1	Float Set (Carburetor No. Be66N A)
❹	16015-ZE0-831	1	Float Chamber Set
❺	16016-ZH7-W01	1	Pilot Screw Set
❻	16024-ZE1-811	1	Drain Screw Set
❼	16028-ZE0-005	1	Screw Set
❽	16045-ZE7-005	1	Choke Set (Carburetor No. Be66J A)
❽	16045-Z1V-G01	1	Choke Set (Carburetor No. Be66N A)
❾	16100-Z1V-003	1	Carburetor ASM (Be66J A) (Engine Serial No. Up To 1001679)
❾	16100-Z1V-801	1	Carburetor ASM (Be66N A) (Engine Serial No. From 1001680)
❿	16124-ZE0-005	1	Screw- Stop, Throttle

Ref	Part No.	Qty.	Description
❶	16166-Z1V-003	1	Nozzle-Main (Carburetor No. Be66J A)
❶	16166-Z1V-801	1	Nozzle-Main (Carburetor No. Be66N A)
❷	16211-ZE7-000	1	Insulator-Carburetor
❸	16212-ZE7-M10	1	Gasket-Insulator
❹	16220-ZE6-010	1	Spacer-Carburetor
❺	16221-ZE7-M11	1	Gasket-Carburetor
❻	16953-ZE1-812	1	Lever-Petcock
❼	16954-ZE1-812	1	Plate-Setting, Lever
❽	16956-ZE1-811	1	Spring-Lever, Petcock
❾	16957-ZE1-812	1	Gasket-Petcock
❿	93500-03006-0H	2	Screw-Pan (3X6)
❶	99101-ZH8-0600	1	Jet-Main (No. 60) (Carburetor No. Be66J A)
❶	99101-ZH8-0620	1	Jet-Main (No. 62)

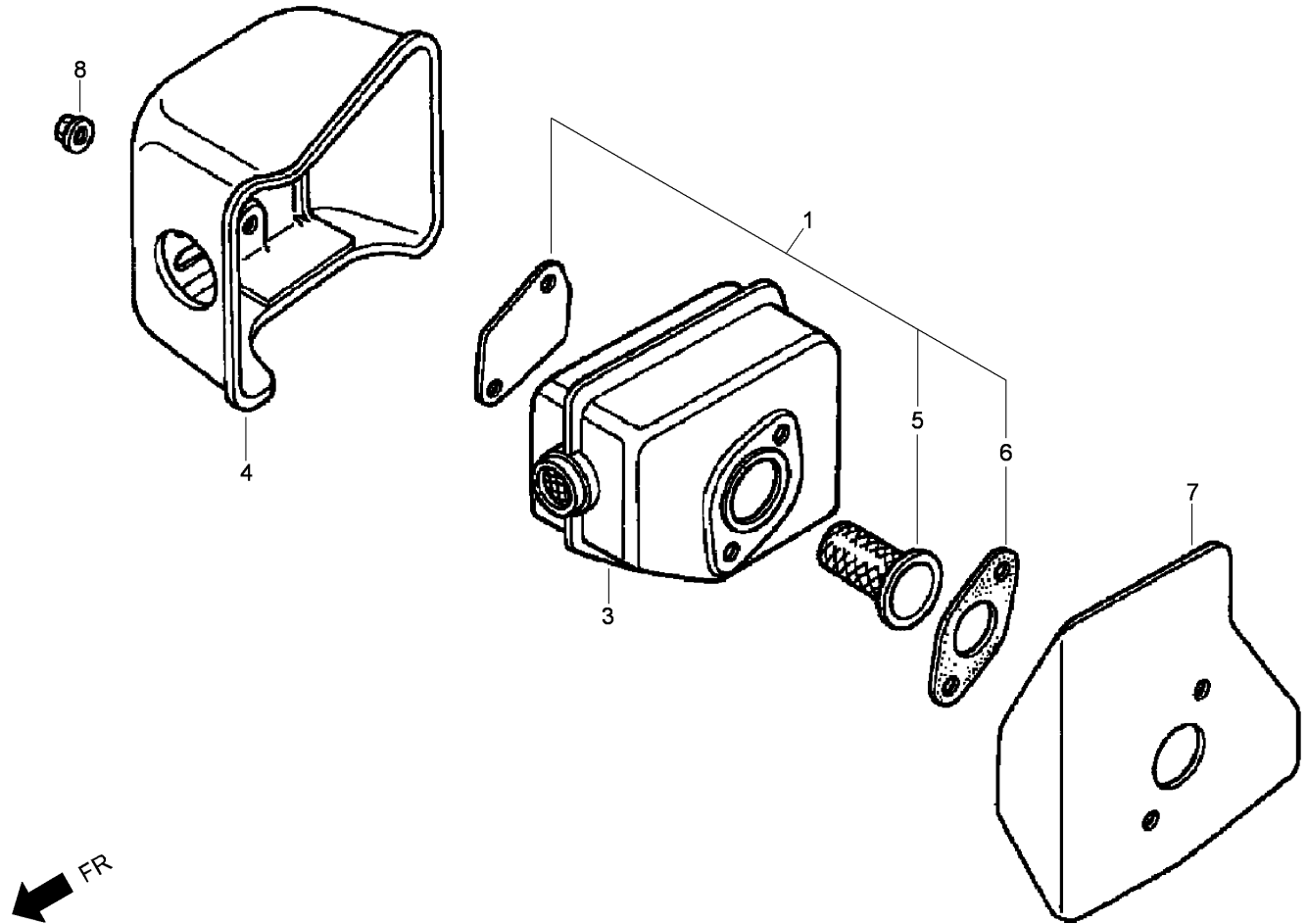

Muffler Assembly Honda GXV160UH2 T1AH

Ref	Part No.	Qty.	Description				
❶	06180-ZE6-820	1	Spark Arrester Kit				
❸	18310-ZE7-W40	1	Muffler				
❸	18310-ZE7-013	1	Muffler				
❹	18320-Z1V-000	1	Protector-Muffler				
❺	06180-888-505	1	Spark Arrester Kit				
❻	18381-ZE6-820	1	Gasket-Muffler				
❼	18381-Z1V-000	1	Gasket-Muffler				
❽	90343-ZE6-000	2	Nut-Lock, Self (6 Mm)				

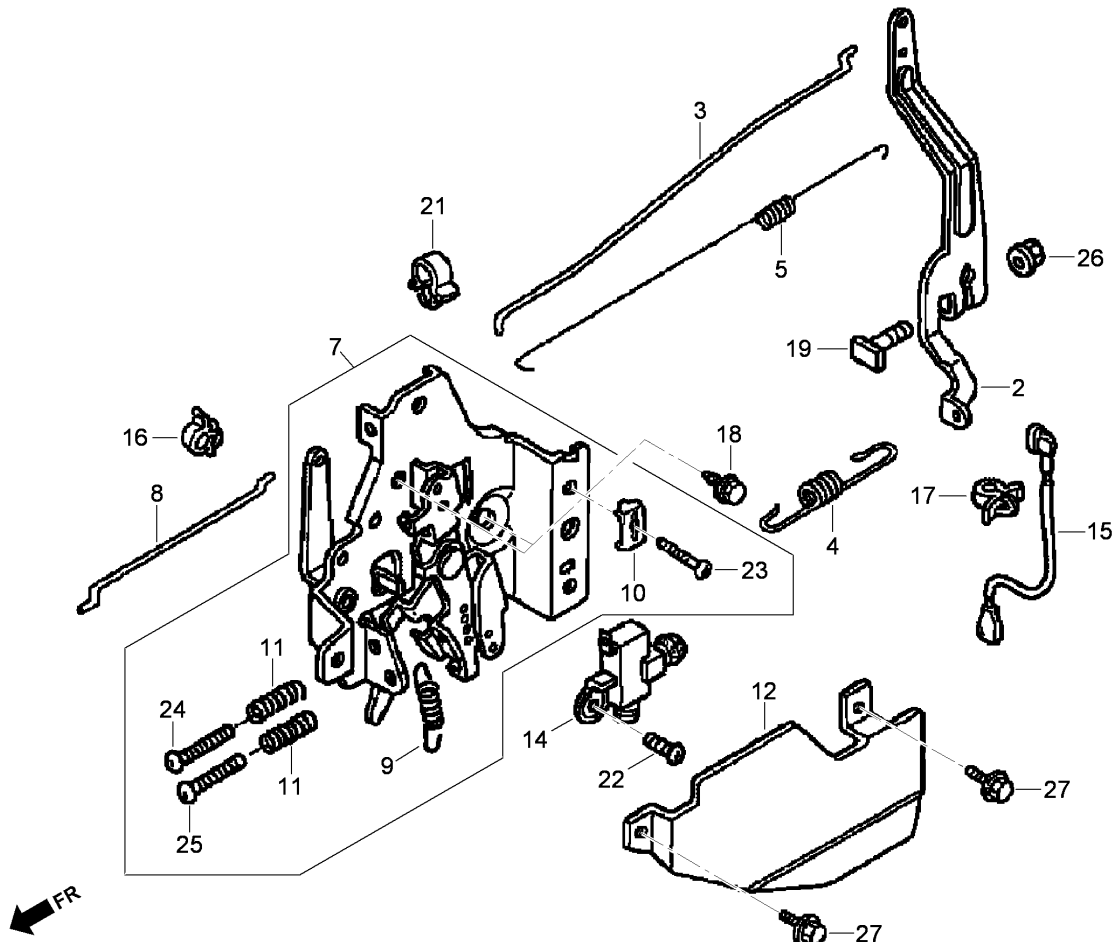

Control Assembly Honda GXV160UH2 T1AH

Ref	Part No.	Qty.	Description
②	16551-ZE7-000	1	Arm-Governor
③	16555-ZE7-000	1	Rod-Governor
④	16561-ZE7-020	1	Spring-Governor (STD)
⑤	16562-ZE6-000	1	Spring-Return, Throttle
⑦	16570-ZE7-020	1	Control ASM
⑧	16573-ZE7-000	1	Rod-Choke
⑨	16576-ZE7-300	1	Spring-Lever
⑩	16576-891-000	1	Holder-Cable
⑪	16584-883-300	2	Spring-Adjusting, Control
⑫	16585-ZE7-000	1	Protector-Control
⑭	36100-ZE7-013	1	Engine Stop Switch ASM
⑮	36101-ZE7-020	1	Wire-Switch, Stop
⑯	36103-ZE1-000	1	Holder-Wire, Stop Switch

Ref	Part No.	Qty.	Description
⑰	46392-SC2-003	1	Clamp-Pipe, Brake
⑱	90013-883-000	2	Bolt-Flange (6X12) (C T200)
⑲	90015-ZE5-010	1	Bolt-Arm, Governor
⑳	90659-680-013	1	Clip-Harness, Wire
㉑	93500-04008-0A	1	Screw-Pan (4X8)
㉒	93500-05016-0A	1	Screw-Pan (5X16)
㉓	93500-05020-0A	1	Screw-Pan (5X20)
㉔	93500-05028-0A	1	Screw-Pan (5X28)
㉕	94050-06000	1	Nut-Flange (6 Mm)
㉖	95701-06010-00	2	Bolt-Flange (6X10)

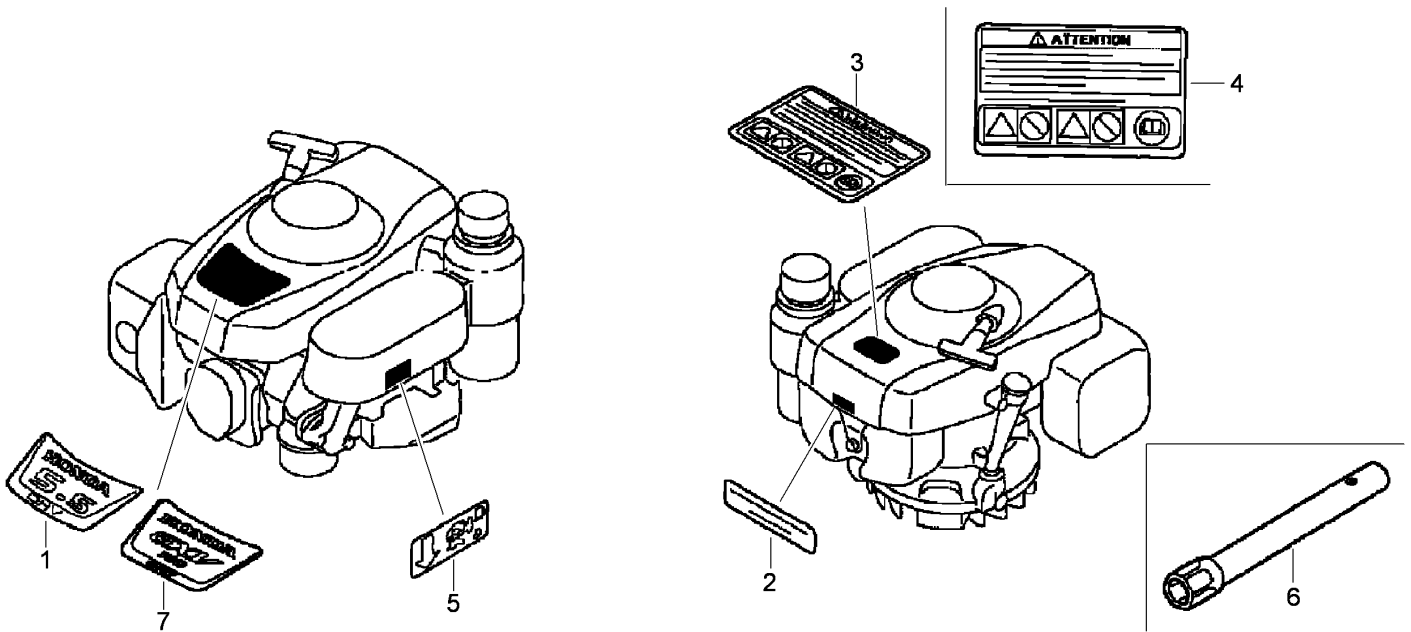

Label and Tool Assemblies Honda GXV160UH2 T1AH

Ref	Part No.	Qty.	Description
❶	87101-Z1V-000	1	Mark, Emblem (Serial Numbers Up To 1036455)
❷	87504-Z1V-000	1	Mark-Manufacturer
❸	87516-Z4N-000	1	Mark-Caution, Operator (English)
❸	87516-Z4N-810	1	Mark-Caution, Operator (French)
❹	87516-Z4N-800	1	Mark-Caution, Operator (Pictograph)
❺	87524-Z1V-000	1	Mark-Caution, Fuel Petcock
❻	99004-21003	1	Wrench-Box (P21)
❼	87101-Z1V-010	1	Mark, Emblem (Gxv160) (Serial Numbers From 1036456)

--	--	--	--

NOTES

NOTES

