



Count on it.

Operator's Manual

G132 and H132 Rear-Engine Riding Mower

Model No. 70185—Serial No. 28000001 and Up

Model No. 70186—Serial No. 28000001 and Up



Introduction

Read this information carefully to learn how to operate and maintain your product properly and to avoid injury and product damage. You are responsible for operating the product properly and safely.

You may contact Toro directly at www.Toro.com for product and accessory information, help finding a dealer, or to register your product.

Whenever you need service, genuine Toro parts, or additional information, contact an Authorized Service Dealer or Toro Customer Service and have the model and serial numbers of your product ready. Figure 1 identifies the location of the model and serial numbers on the product. Write the numbers in the space provided.

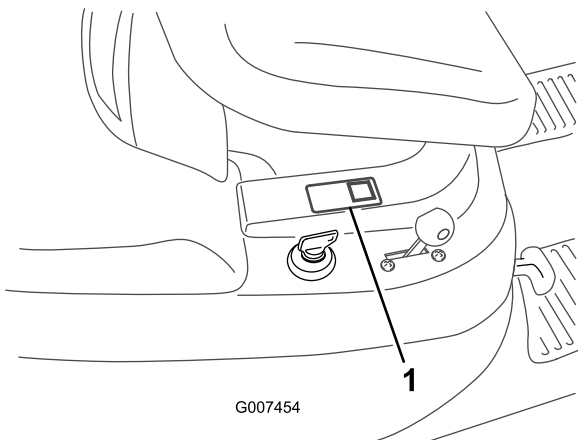

G007454

Figure 1

1. Model and serial number location

Model No. _____
Serial No. _____

This manual identifies potential hazards and has safety messages identified by the safety alert symbol (Figure 2), which signals a hazard that may cause serious injury or death if you do not follow the recommended precautions.



Figure 2

1. Safety alert symbol

This manual uses 2 words to highlight information. **Important** calls attention to special mechanical information and **Note** emphasizes general information worthy of special attention.

Contents

Introduction.....	2
Safety	3
Safe Operating Practices	3
Toro Riding Mower Safety	5
Sound Pressure.....	5
Sound Power	5
Vibration.....	5
Slope Chart	6
Safety and Instructional Decals	7
Product Overview	9
Controls	9
Operation.....	10
Adding Fuel	10
Checking the Engine Oil Level.....	11
Starting the Engine.....	11
Stopping the Engine.....	12
Driving the Machine Forward or Backward	12
Selecting Ground Speeds	13
Driving the Machine Forward or Backward	13
Stopping the Machine.....	13
Pushing the Machine Manually.....	13
Using the Safety Interlock System	14
Testing the Safety Interlock System	15
Testing the Safety Interlock System	16
Emptying the Grass Collector.....	16
Installing the Recycler Cover.....	17
Installing the Discharge Chute	18
Operating Tips	19
Maintenance.....	20
Recommended Maintenance Schedule(s)	20
Lubrication.....	20
Greasing and Lubricating the Machine	20
Engine Maintenance.....	20
Servicing the Engine Oil.....	20
Servicing the Air Cleaner	22
Servicing the Spark Plug	23
Fuel System Maintenance	24
Draining the Fuel Tank.....	24
Replacing the Fuel Filter	24
Electrical System Maintenance.....	25
Servicing the Battery.....	25
Servicing the Fuses.....	27
Brake Maintenance.....	27

Checking the Parking Brake	27
.....	28
Checking the Tire Pressure	28
Servicing the Blade	28
Leveling the Mower	29
Cleaning.....	30
Washing under the Mower	30
Washing the Machine.....	30
Storage.....	31
Cleaning and Storage	31
Troubleshooting.....	32
Schematics	34

Safety

This machine meets or exceeds European Standards in effect at the time of production. However, improper use or maintenance by the operator or owner can result in injury. To reduce the potential for injury, comply with these safety instructions and always pay attention to the safety alert symbol, which means CAUTION, WARNING, or DANGER-"personal safety instruction." Failure to comply with the instruction may result in personal injury or death.

Safe Operating Practices

The following instructions are from the CEN standard EN 836:1997.

This product is capable of amputating hands and feet and throwing objects. Always follow all safety instructions to avoid serious injury or death.

Training

- Read the instructions carefully. Be familiar with the controls and the proper use of the equipment.
- Never allow children or people unfamiliar with these instructions to use the lawnmower. Local regulations can restrict the age of the operator.
- Never mow while people, especially children, or pets are nearby.
- Keep in mind that the operator or user is responsible for accidents or hazards occurring to other people or their property.
- Do not carry passengers.
- All drivers should seek and obtain professional and practical instruction. Such instruction should emphasize:
 - the need for care and concentration when working with ride-on machines;
 - control of a ride-on machine sliding on a slope will not be regained by the application of the control levers. The main reasons for loss of control are:
 - ◇ insufficient wheel grip, especially on wet grass;
 - ◇ being driven too fast;
 - ◇ inadequate braking;
 - ◇ the type of machine is unsuitable for its task;
 - ◇ lack of awareness of the effect of ground conditions, especially slopes;
 - ◇ incorrect hitching and load distribution.

Preparation

- While mowing, always wear substantial footwear and long trousers. Do not operate the equipment when barefoot or wearing open sandals.
- Thoroughly inspect the area where the equipment is to be used and remove all objects which may be thrown by the machine.
- **Warning**—Fuel is highly flammable.
 - Store fuel in containers specifically designed for this purpose.
 - Refuel outdoors only and do not smoke while refuelling.
 - Add fuel before starting the engine. Never remove the cap of the fuel tank or add fuel while the engine is running or when the engine is hot.
 - If fuel is spilled, do not attempt to start the engine but move the machine away from the area of spillage and avoid creating any source of ignition until fuel vapors have dissipated.
 - Replace all fuel tanks and container caps securely.
- Replace faulty silencers.
- Before using, always visually inspect to see that the blades, blade bolts and cutter assembly are not worn or damaged. Replace worn or damaged blades and bolts in sets to preserve balance.
- On multi-bladed machines, take care as rotating one blade can cause other blades to rotate.

Operation

- Be alert, slow down and use caution when making turns. Look behind and to the side before changing directions.
 - Do not operate the engine in a confined space where dangerous carbon monoxide fumes can collect.
 - Mow only in daylight or in good artificial light.
 - Before attempting to start the engine, disengage all blade attachment clutches and shift into neutral.
 - Do not use on slopes greater than 15 degrees.
 - Remember there is no such thing as a safe slope. Travel on grass slopes requires particular care. To guard against overturning:
 - - do not stop or start suddenly when on a slope;
 - - use slow speeds on slopes and during tight turns;
 - - stay alert for humps and hollows and other hidden hazards;
 - Use care when pulling loads or using heavy equipment.
 - - Use only approved drawbar hitch points.
 - - Limit loads to those you can safely control.
 - - Do not turn sharply. Use care when reversing.
- Watch out for traffic when crossing or near roadways.
 - Stop the blades rotating before crossing surfaces other than grass.
 - When using any attachments, never direct discharge of material toward bystanders nor allow anyone near the machine while in operation.
 - Never operate the machine with damaged guards or without safety protective devices in place.
 - Do not change the engine governor settings or overspeed the engine. Operating the engine at excessive speed can increase the hazard of personal injury.
 - Before leaving the operator's position:
 - disengage the power take-off and lower the attachments;
 - change into neutral and set the parking brake;
 - stop the engine and remove the key.
 - Disengage drive to attachments, stop the engine, and disconnect the spark plug wire(s) or remove the ignition key
 - before clearing blockages or unclogging chute;
 - before checking, cleaning or working on the lawn mower;
 - after striking a foreign object. Inspect the lawn mower for damage and make repairs before restarting and operating the equipment; if the machine starts to vibrate abnormally (check immediately).
 - Disengage drive to attachments when transporting or not in use.
 - Stop the engine and disengage drive to attachment
 - before refuelling;
 - before removing the grass catcher;
 - before making height adjustment unless adjustment can be made from the operator's position.
 - Reduce the throttle setting during engine run-out and, if the engine is provided with a shut-off valve, turn the fuel off at the conclusion of mowing.

Maintenance and Storage

- Keep all nuts, bolts and screws tight to be sure the equipment is in safe working condition.
- Never store the equipment with fuel in the tank inside a building where fumes can reach an open flame or spark.

- Allow the engine to cool before storing in any enclosure.
- To reduce the fire hazard, keep the engine, silencer, battery compartment and fuel storage area free of grass, leaves, or excessive grease.
- Check the grass catcher frequently for wear or deterioration.
- Replace worn or damaged parts for safety.
- If the fuel tank has to be drained, this should be done outdoors.
- On multi-bladed machines, take care as rotating one blade can cause other blades to rotate.
- When machine is to be parked, stored or left unattended, lower the cutting means unless a positive mechanical lock is used.
- Do not make sudden turns or rapid speed changes.
- Use a walk behind mower and/or a hand trimmer near drop-offs, ditches, steep banks or water.
- Reduce speed and use extreme caution on slopes.
- Remove or mark obstacles such as rocks, tree limbs, etc. from the mowing area. Tall grass can hide obstacles.
- Watch for ditches, holes, rocks, dips, and rises that change the operating angle, as rough terrain could overturn the machine.
- Avoid sudden starts when mowing uphill because the mower may tip backwards.
- Be aware that loss of traction may occur going downhill. Weight transfer to the front wheels may cause drive wheels to slip and cause loss of braking and steering.
- Always avoid sudden starting or stopping on a slope. If tires lose traction, disengage the blades and proceed slowly off the slope.
- Follow the manufacturer's recommendations for wheel weights or counterweights to improve stability.
- Use extreme care with grass catchers or other attachments. These can change the stability of the machine and cause loss of control.

Toro Riding Mower Safety

The following list contains safety information specific to Toro products or other safety information that you must know that is not included in the CEN standard.

- Engine exhaust contains carbon monoxide, which is an odorless, deadly poison that can kill you. Do not run engine indoors or in an enclosed area.
- Keep hands, feet, hair and loose clothing away from attachment discharge area, underside of mower and any moving parts while engine is running.
- Do not touch equipment or attachment parts which may be hot from operation. Allow to cool before attempting to maintain, adjust, or service.
- Battery acid is poisonous and can cause burns. Avoid contact with skin, eyes and clothing. Protect your face, eyes, and clothing when working with a battery.
- Battery gases can explode. Keep cigarettes, sparks and flames away from battery.
- Use only genuine Toro replacement parts to ensure that original standards are maintained.
- Use only Toro-approved attachments. Warranty may be voided if used with unapproved attachments.

Slope Operation

- Do not mow slopes greater than 15 degrees.
- Do not mow near drop-offs, ditches, steep banks or water. Wheels dropping over edges can cause rollovers, which may result in serious injury, death or drowning.
- Do not mow slopes when grass is wet. Slippery conditions reduce traction and could cause sliding and loss of control.

Sound Pressure

This unit has a maximum sound pressure level at the operator's ear of 87 dBA, based on measurements of identical machines per EN 11094 and EN 836.

Sound Power

This unit has a guaranteed sound power level of 100 dBA, based on measurements of identical machines per EN 11094.

Vibration

This unit does not exceed a whole body vibration level of 0.5 m/s², based on measurements of identical machines per EN 1032.

Slope Chart

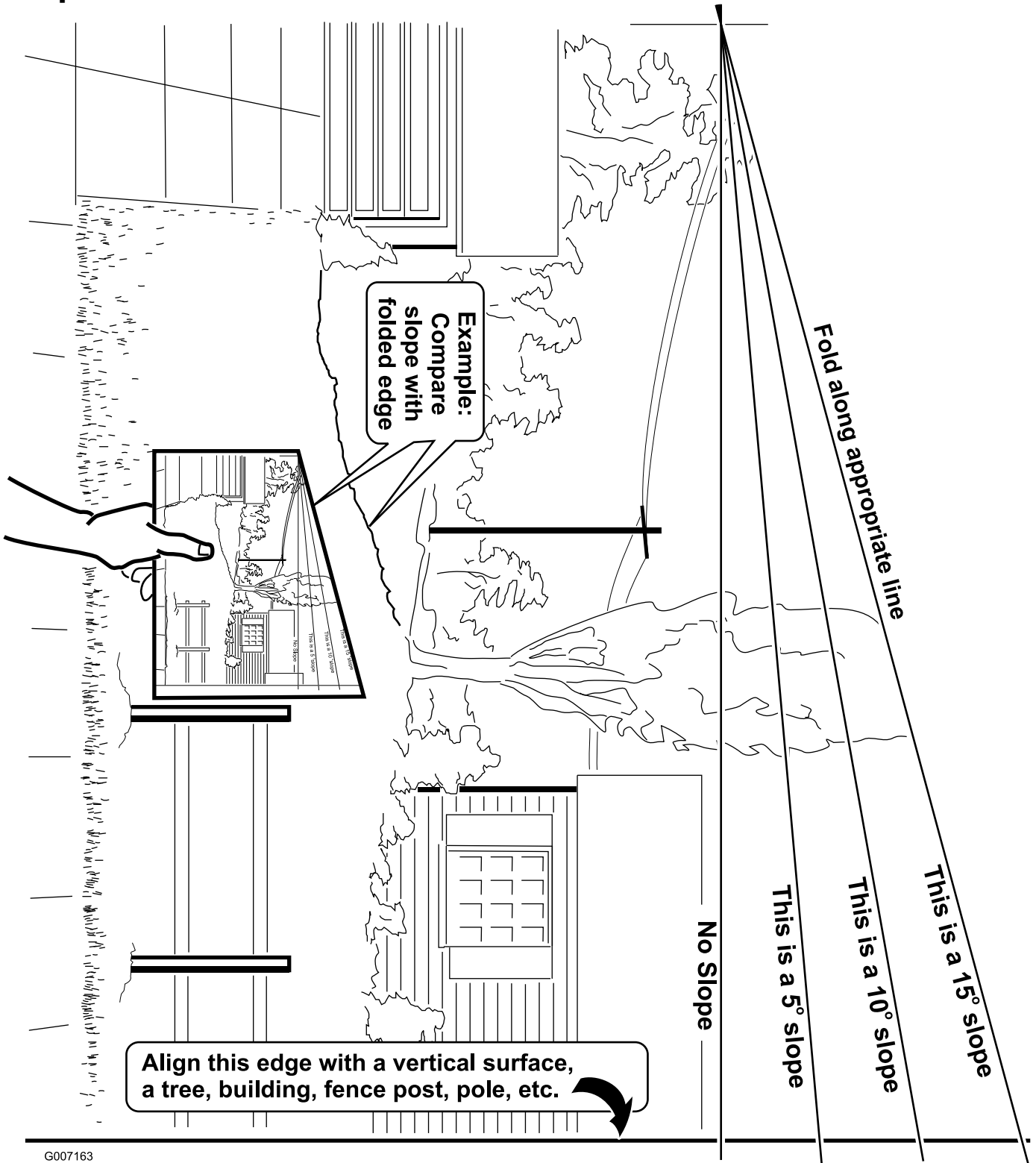

G007163

Safety and Instructional Decals



Safety decals and instructions are easily visible to the operator and are located near any area of potential danger. Replace any decal that is damaged or lost.

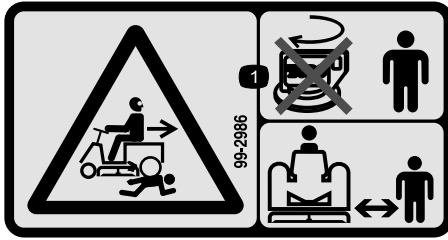

99-2986

1. Crushing/dismemberment hazard of bystanders—do not turn the key while children are present; keep children a safe distance from the machine.



105-0529

1. Warning—do not touch the hot surfaces.

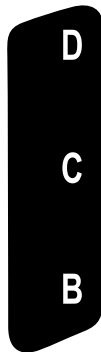

105-0530

1. Height of cut



105-0531

1. Disengage the cutting blade.

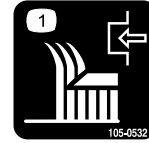

105-0532

1. Engage the cutting blade.



105-0535

1. Grass collector full
2. Operating in reverse

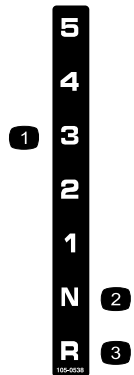

105-0538

1. Transmission speeds
2. Neutral
3. Reverse



106-1802

1. Warning—read the *Operator's Manual*.
2. Cutting/dismemberment hazard of hand—remove the ignition key and read the instructions before servicing or performing maintenance.
3. Thrown object hazard—keep bystanders a safe distance from the machine.
4. Tipping hazard—do not operate on slopes greater than 10 degrees.

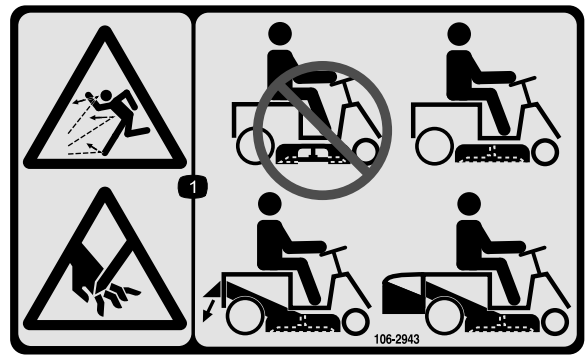

106-2943

1. Thrown object hazard; cutting/dismemberment hazard—do not operate the machine with the discharge opening uncovered; always operate the machine with the recycling cover, rear discharge deflector, or grass collector installed.

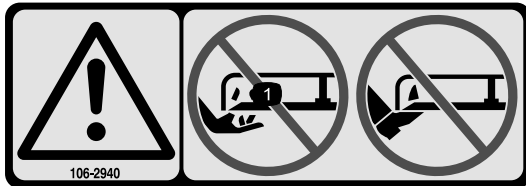

106-2940

1. Warning—do not place your hands or feet under the mower.

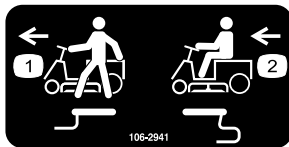

106-2941

Model 70186 only

1. Push the lever in to push the machine.
2. Pull the lever out to drive the machine.



106-2942

1. Turn the key to mow in reverse.

Product Overview

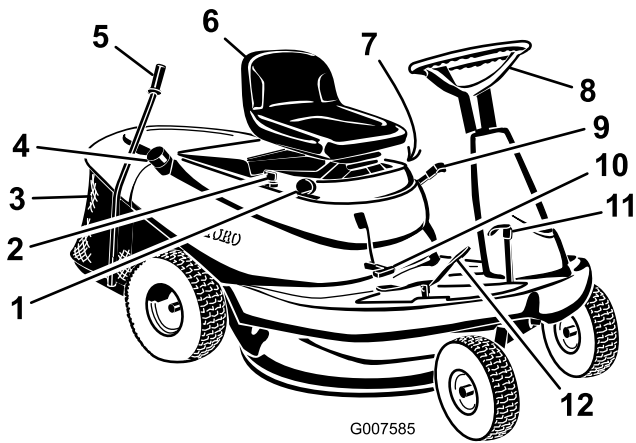

Figure 3

- | | |
|------------------|---------------------------------|
| 1. Throttle | 7. KeyChoice switch (not shown) |
| 2. Ignition key | 8. Steering wheel |
| 3. Collector bin | 9. Height-of-cut lever |
| 4. Fuel tank cap | 10. Blade control (PTO) |
| 5. Collector rod | 11. Brake pedal |
| 6. Seat | 12. Ground speed pedal |

Note: The brake pedal should stay in the depressed (locked) position.

Releasing the Parking Brake

1. Push down on the brake pedal (Figure 4) and hold it.
2. Push the parking brake lever (Figure 4) down and gradually release the brake pedal.

Positioning the Seat

The seat can move forward and backward. Position the seat where you have the best control of the machine and are most comfortable.

1. Raise the seat and loosen the 4 bolts (Figure 5).

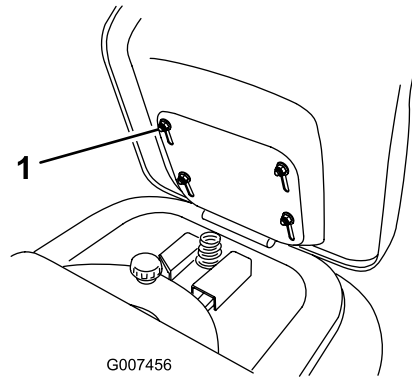

Figure 5

1. Bolt (4)
-
2. Move the seat to the desired position and tighten the bolts.

Controls

Become familiar with the controls before you start the engine and operate the machine.

Using the Parking Brake

Always set the parking brake whenever you stop the machine or leave it unattended.

Setting the Parking Brake

1. Push the brake pedal down and hold it (Figure 4).

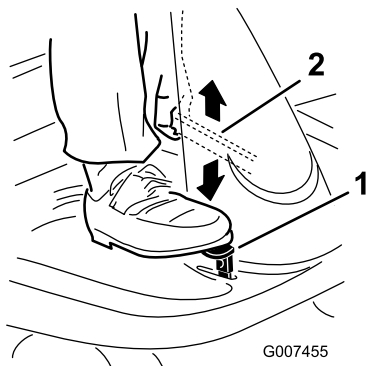

Figure 4

1. Brake pedal
2. Parking brake lever

Using the Blade Control (PTO)

The blade control (PTO) lever engages and disengages power to the blade.

Engaging the Blade

1. Depress the brake pedal to stop the machine.
2. Slowly shift the blade control (PTO) to Engage (Figure 6).

2. Lift the parking brake lever (Figure 4) up and gradually take your foot off the brake pedal.

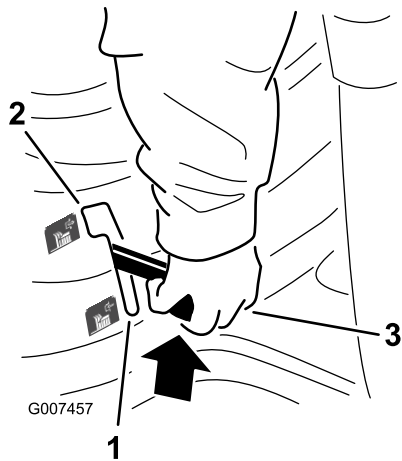

Figure 6

1. Disengage
2. Engage
3. Blade control (PTO)

Disengaging the Blade

1. Depress the brake pedal to stop the machine.
2. Shift the blade control (PTO) to Disengage (Figure 6).

Setting the Height of Cut

Use the height-of-cut lever to raise and lower the mower to the desired cutting height. You can set the cutting height to 1 of 4 positions from approximately 3.8 to 9 cm.

1. Disengage the blade control (PTO).
2. Pull on the height-of-cut lever, move it to the desired position, and release it slowly into the notch (Figure 7).

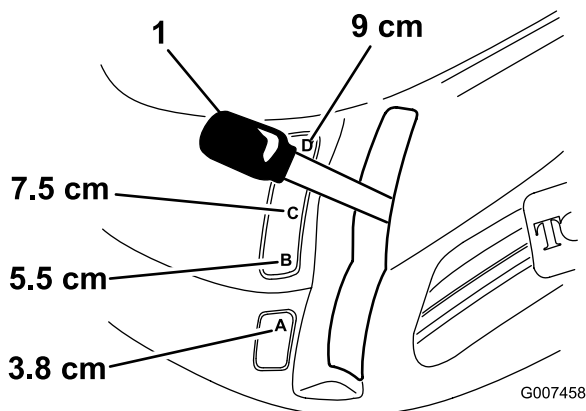

Figure 7

1. Height-of-cut lever

Operation

Note: Determine the left and right sides of the machine from the normal operating position.

Adding Fuel

Use **Unleaded** Regular Gasoline suitable for automotive use (85 pump octane minimum). Leaded regular gasoline may be used if unleaded regular is not available.

Important: Never use methanol, gasoline containing methanol, or gasohol containing more than 10% ethanol because the fuel system could be damaged. Do not mix oil with gasoline.



In certain conditions, gasoline is extremely flammable and highly explosive. A fire or explosion from gasoline can burn you and others and can damage property.

- Fill the fuel tank outdoors, in an open area, when the engine is cold. Wipe up any gasoline that spills.
- Never fill the fuel tank inside an enclosed trailer.
- Do not fill the fuel tank completely full. Add gasoline to the fuel tank until the level is 1/4 to 1/2 inch (6 to 13 mm) below the bottom of the filler neck. This empty space in the tank allows gasoline to expand.
- Never smoke when handling gasoline, and stay away from an open flame or where gasoline fumes may be ignited by a spark.
- Store gasoline in an approved container and keep it out of the reach of children. Never buy more than a 30-day supply of gasoline.
- Do not operate without entire exhaust system in place and in proper working condition.



In certain conditions during fueling, static electricity can be released causing a spark which can ignite the gasoline vapors. A fire or explosion from gasoline can burn you and others and can damage property.

- Always place gasoline containers on the ground away from your vehicle before filling.
- Do not fill gasoline containers inside a vehicle or on a truck or trailer bed because interior carpets or plastic truck bed liners may insulate the container and slow the loss of any static charge.
- When practical, remove gas-powered equipment from the truck or trailer and refuel the equipment with its wheels on the ground.
- If this is not possible, then refuel such equipment on a truck or trailer from a portable container, rather than from a gasoline dispenser nozzle.
- If a gasoline dispenser nozzle must be used, keep the nozzle in contact with the rim of the fuel tank or container opening at all times until fueling is complete.



Gasoline is harmful or fatal if swallowed. Long-term exposure to vapors can cause serious injury and illness.

- Avoid prolonged breathing of vapors.
- Keep face away from nozzle and gas tank or conditioner opening.
- Keep gas away from eyes and skin.

Using Stabilizer/Conditioner

Use a fuel stabilizer/conditioner in the machine to provide the following benefits:

- Keeps gasoline fresh during storage of 90 days or less. For longer storage it is recommended that the fuel tank be drained.
- Cleans the engine while it runs
- Eliminates gum-like varnish buildup in the fuel system, which causes hard starting

Important: Do not use fuel additives containing methanol or ethanol.

Add the correct amount of gas stabilizer/conditioner to the gas.

Note: A fuel stabilizer/conditioner is most effective when mixed with fresh gasoline. To minimize the chance of varnish deposits in the fuel system, use fuel stabilizer at all times.

Filling the Fuel Tank

1. Shut the engine off and set the parking brake.
2. Clean around each fuel tank cap and remove the cap.
3. Add unleaded regular gasoline to both fuel tanks, until the level is 1/4 to 1/2 inch (6 mm to 13 mm) below the bottom of the filler neck.

This space in the tank allows gasoline to expand. Do not fill the fuel tanks completely full.
4. Install fuel tank caps securely.
5. Wipe up any gasoline that may have spilled.

Checking the Engine Oil Level

Before you start the engine and use the machine, check the oil level in the engine crankcase; refer to Checking Oil Level in Maintenance.

Starting the Engine

1. Sit down on the seat.
2. Set the parking brake; refer to Setting the Parking Brake.
Note: The engine will not start unless you engage the parking brake.
3. Shift the ground speed lever into Neutral (N) (Figure 8).

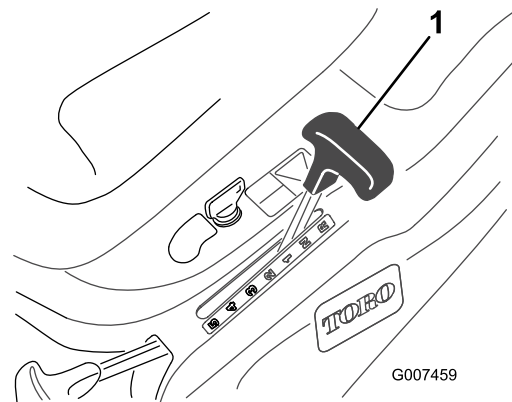

Figure 8

1. Ground speed lever

- Shift the blade control (PTO) lever to Disengage (Figure 9).

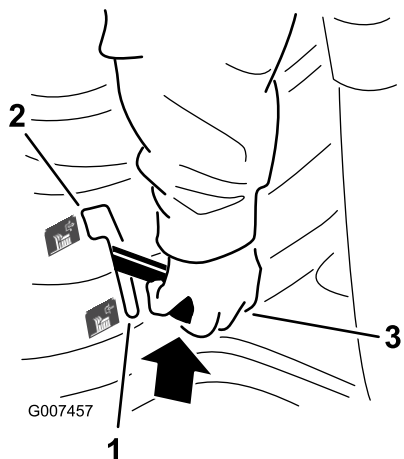

Figure 9

- Disengage
- Engage
- Blade control (PTO)

- Shift the throttle lever to Choke (Figure 10).

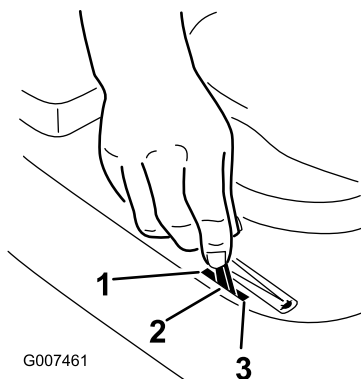

Figure 10

- Choke
- Fast
- Slow

Note: An engine that has been running and is warm may not require this step.

- Turn the ignition key clockwise and hold it in the Start position (Figure 11). When the engine starts, release the key.

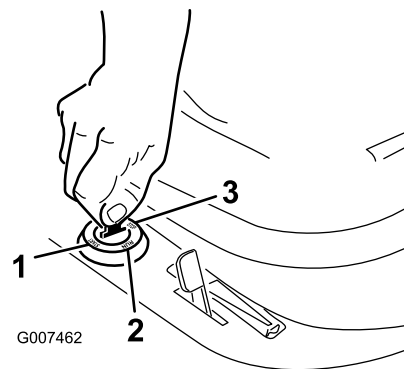

Figure 11

- Start
- Run
- Stop

Important: If the engine does not start after 30 seconds of continuous cranking, turn the ignition key to Stop and let the starter motor cool; refer to Troubleshooting.

- After the engine starts, slowly shift the throttle lever to Fast (Figure 10). If the engine stalls or hesitates, shift the throttle lever back to Choke for a few seconds and then shift the throttle lever to Fast. Repeat this step as required.

Stopping the Engine

- Shift the throttle lever to Slow (Figure 10).
- Turn the ignition key to Stop (Figure 11).
- Remove the ignition key.

Driving the Machine Forward or Backward

Model 70185 only

The throttle control regulates the engine speed as measured in RPM (revolutions per minute).

- Release the parking brake; refer to Releasing the Parking Brake.
- Depress the brake pedal.
- Shift the ground speed lever to the desired forward speed or to Reverse.

Note: As you slowly release the pedal, the machine will begin to move. Steer the machine with the steering wheel.



Suddenly releasing the clutch pedal could cause you to lose control and suddenly put the machine in motion.

Always release the clutch pedal slowly when starting the machine in motion.

Selecting Ground Speeds

Model 70185 only

Important: To avoid transmission damage, always depress the brake pedal before shifting into or out of Reverse.

Always start the machine in motion by depressing the brake pedal and shifting into the desired speed. Once the machine is in motion, you can shift into any forward speed without depressing the brake pedal. In most conditions, the machine is powerful enough to move out in any speed. If it will not move out in a selected speed due to a heavy load, shift to a lower speed.

Important: Do not shift on slopes. Choose a slow speed so that you will not have to stop or shift while on the slope.

Driving the Machine Forward or Backward

Model 70186 only

The throttle control regulates the engine speed as measured in RPM (revolutions per minute).

1. Release the parking brake; refer to Releasing the Parking Brake.
2. Place your foot on the traction control pedal.
3. Slowly press on the top of the pedal to move the machine forward or on the bottom of the pedal to move the machine backward.

Note: The farther you move the traction control pedal in either direction, the faster the machine moves in that direction. To slow down, release the pressure on the pedal. Steer the machine with the steering wheel.

Important: To avoid transmission damage, always release the parking brake before moving the traction control pedal.



Suddenly releasing the brake pedal could cause you to lose control and suddenly put the machine in motion.

Always release the brake pedal slowly when starting the machine in motion.

Stopping the Machine

1. Depress the brake pedal (model 70185 only).
2. Shift the ground speed lever into Neutral (model 70185 only).
3. Release the traction control pedal (model 70186 only).
4. Disengage the blade control (PTO).
5. Turn the ignition key to Off to stop the engine.
6. Wait for all moving parts to stop.
7. Set the parking brake if you leave the machine unattended; refer to Setting the Parking Brake.
8. Remove the ignition key from the switch.



Children or bystanders may be injured if they move or attempt to operate the machine while it is unattended.

Always remove the ignition key and set the parking brake when leaving the machine unattended, even if just for a few minutes.

Pushing the Machine Manually

Important: Always push the machine manually. Never tow the machine because you may damage the transaxle.

1. Shift the ground speed lever into Neutral (model 70185 only).
2. Disengage the blade (PTO).
3. Stop the engine and wait for all moving parts to stop.
4. Remove the ignition key.
5. Push the drive control rod in and slide it to the left to lock it in place (model 70186 only) (Figure 12).

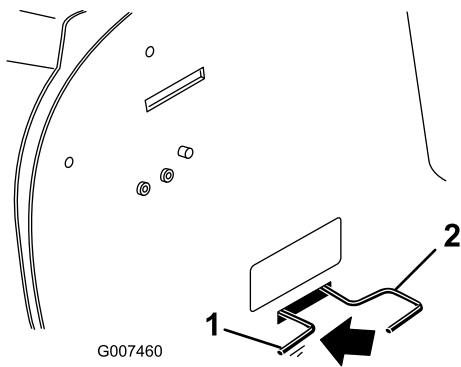

Figure 12

1. Push position
2. Operate position

Note: This disengages the drive system and allows the wheels to turn freely.

6. Lower the grass collector (model 70186 only).
7. Disengage the parking brake.

Note: To operate the machine: Raise the grass collector, slide the drive control rod the right and pull it out, and then lower the grass collector.

Using the Safety Interlock System



If the safety interlock switches are disconnected or damaged, the machine could operate unexpectedly, causing personal injury.

- Do not tamper with the interlock switches.
- Check the operation of the interlock switches daily and replace any damaged switches before operating the machine.

Understanding the Safety Interlock System

The safety interlock system is designed to prevent the engine from starting unless:

- You are sitting on the seat.
- The brake pedal is depressed.
- The blade control (PTO) lever is in the Disengage position.

The safety interlock system is designed to stop the engine if you do the following:

- You rise from the seat when the brake pedal is released.

- You rise from the seat when the blade control (PTO) lever is in the Engage position.
- You shift into reverse while the blade control (PTO) lever is in the Engage position and the operating-in-reverse interlock is not deactivated.
- You remove the grass collector or the rear deflector when the blade control (PTO) lever is in the Engage position.

Setting the KeyChoice® Switch to Operate in Reverse

An interlock feature on the machine prevents the power take-off (PTO) from operating when you back up the machine. If you put the traction control pedal into Reverse with the PTO engaged (i.e., with mower blades or other attachment running), the engine will stop. **Do not mow in reverse unless it is absolutely necessary.**

If you need to use the blade control (PTO) while backing up, turn off the interlock feature using the KeyChoice switch located near the seat bracket (Figure 13).

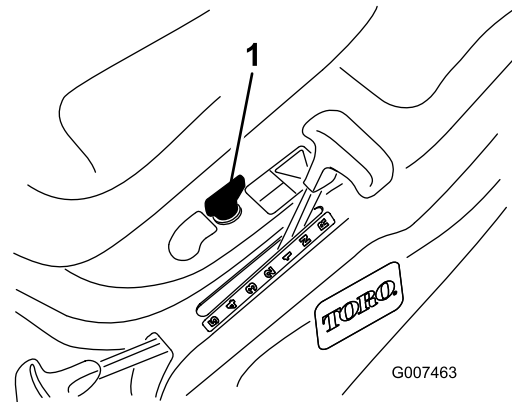

Figure 13

1. KeyChoice switch



You could back over a child or bystander while the mower blade or other attachment is engaged and cause serious injury or death.

- Do not mow in reverse unless absolutely necessary.
- Do not insert the KeyChoice key unless it is absolutely necessary.
- Always look backward and down before backing up.
- Use the KeyChoice switch only if you are certain no children or other bystanders will enter the mowing area.
- Be very observant after deactivating the interlock because the sound of the engine may prevent you from noticing that a child or bystander has entered the work area.
- Always remove both the ignition and KeyChoice keys and put them in a safe place out of the reach of children or unauthorized users when leaving the unit unattended.

1. Engage the blade (PTO).
2. Insert the KeyChoice key into the switch (Figure 13).
3. Turn the KeyChoice key.

Note: A red light on the front console (Figure 14) turns on, indicating that the interlock is disabled.

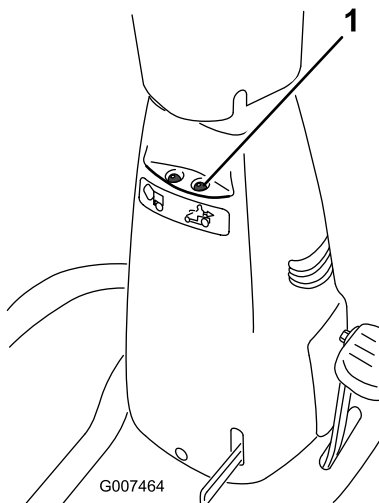

Figure 14

1. Operating-in-reverse light

4. Shift the ground speed lever into Reverse and complete your task (model 70185 only) .

5. Put the traction control pedal into Reverse and complete your task (model 70186 only).
6. Disengage the blade (PTO) to activate the interlock.
7. Remove the KeyChoice key and put it in a safe place out of the reach of children.

Testing the Safety Interlock System

Model 70185 only



If safety interlock switches are disconnected or damaged, the machine could operate unexpectedly, causing personal injury.

- Do not tamper with the interlock switches.
- Check the operation of the interlock switches daily and replace any damaged switches before operating the machine.

1. Test the safety interlock system before you use the machine each time. If the safety interlock system does not operate as described below, have an Authorized Service Dealer repair it immediately.
2. Shift the blade control (PTO) lever to Engage, sit on the seat, and rotate the ignition key to Start: The engine should not crank. If it does crank, the safety interlock system is malfunctioning and must be repaired by an Authorized Service Dealer. If the engine does not crank, go to step 3.
3. Shift the blade control (PTO) lever to Disengage, sit on the seat, depress the brake and clutch pedals, engage the parking brake, shift the ground speed lever into gear, and rotate the ignition key to Start: The engine should not crank. If it does crank, the safety interlock system is malfunctioning and must be repaired by an Authorized Service Dealer. If the engine does not crank, go to step 4.
4. Sit on the seat, shift the ground speed lever into Neutral, and shift the blade control (PTO) lever to Disengage. Ensure that the parking brake is engaged and rotate the ignition key to Start: The engine should start and continue to run. Then engage the blade control (PTO) lever and carefully rise from the seat: The engine should stop. If the engine does not stop running, stop the engine, wait for all moving parts to stop, and have the safety interlock system repaired by an Authorized Service Dealer. If the engine stops when you rise from the seat, the safety interlock system is functioning properly.

- Shift the blade control (PTO) lever to Disengage, shift the ground speed lever into Neutral, and start the engine. While the engine is running, shift the blade control (PTO) lever to Engage, push in the clutch, and shift the ground speed lever to Reverse: The engine should stop.
- Shift the blade control (PTO) lever to Disengage, shift the ground speed lever to Neutral, and start the engine. Then shift the blade control (PTO) lever to Engage and turn the KeyChoice key and release it: The KeyChoice warning light should illuminate. Shift the blade control (PTO) lever to Disengage: The KeyChoice warning light should turn off.

Testing the Safety Interlock System

Model 70186 only



If safety interlock switches are disconnected or damaged, the machine could operate unexpectedly, causing personal injury.

- Do not tamper with the interlock switches.
- Check the operation of the interlock switches daily and replace any damaged switches before operating the machine.

Test the safety interlock system before you use the machine each time. If the safety interlock system does not operate as described below, have an Authorized Service Dealer repair it immediately.

- Shift the blade control (PTO) lever to Engage, sit on the seat, and rotate the ignition key to Start: The engine should not crank. If it does crank, the safety interlock system is malfunctioning and must be repaired by an Authorized Service Dealer. If the engine does not crank, go to step 2.
- Shift the blade control (PTO) lever to Disengage, sit on the seat, depress the brake pedal, engage the parking brake, and rotate the ignition key to Start: The engine should not crank. If it does crank, the safety interlock system is malfunctioning and must be repaired by an Authorized Service Dealer. If the engine does not crank, go to step 3.
- Sit on the seat, put the traction control pedal into Neutral, and shift the blade control (PTO) lever to Disengage. Ensure that the parking brake is engaged and rotate the ignition key to Start: The engine

should start and continue to run. Then engage the blade control (PTO) lever and carefully rise from the seat: The engine should stop. If the engine does not stop running, stop the engine, wait for all moving parts to stop, and have the safety interlock system repaired by an Authorized Service Dealer. If the engine stops when you rise from the seat, the safety interlock system is functioning properly.

- Shift the blade control (PTO) lever to Disengage, put the traction control pedal into Neutral, and start the engine. While the engine is running, shift the blade control (PTO) lever to Engage and put the traction control pedal to Reverse: The engine should stop.
- Shift the blade control (PTO) lever to Disengage, and start the engine. Then shift the blade control (PTO) lever to Engage and turn the KeyChoice key and release it: The KeyChoice warning light should illuminate. Shift the blade control (PTO) lever to Disengage: The KeyChoice warning light should turn off.

Emptying the Grass Collector

When the collector warning light on the front console comes on, the grass collector is full and must be emptied.

- Disengage the blade control (PTO).
- Pull the collector rod forward to tilt the collection bin (Figure 15).

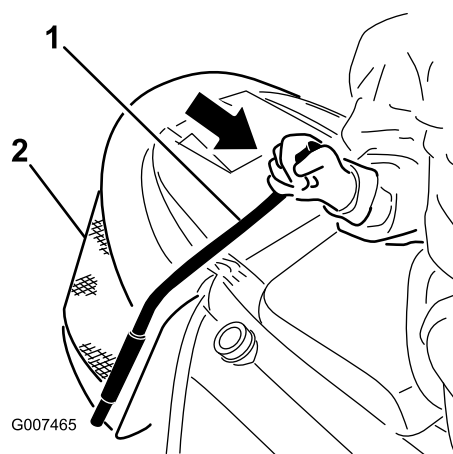

Figure 15

- Collector rod
 - Collection bin
-
- Shake the collection bin until it is completely empty.
 - Slowly return the collection rod to the operating position.

Installing the Recycler Cover

A Recycler cover is included with the machine. You can use it when you do not want to bag the grass clippings.



Without the grass deflector, discharge cover, or complete grass catcher assembly mounted in place, you and others are exposed to blade contact and thrown debris. Contact with the rotating mower blade and thrown debris will cause injury or death.

- Never remove the grass deflector from the mower because the grass deflector routes material down toward the turf. If the grass deflector is ever damaged, replace it immediately.
- Never put your hands or feet under the mower.
- Never try to clear the discharge area or mower blades unless you disengage the power take-off (PTO) and turn the ignition key to Off. Also remove the key and disconnect the wire from the spark plug.

1. Park the machine on a level surface.
2. Disengage the blade (PTO).
3. Shift the ground speed lever into Neutral (model 70185 only).
4. Set the parking brake.
5. Stop the engine and wait for all moving parts to stop.
6. Remove the ignition key.
7. Raise the grass collector and remove the hairpin, 2 washers, and clevis pin that secure the discharge tube to the rear plate (Figure 16).

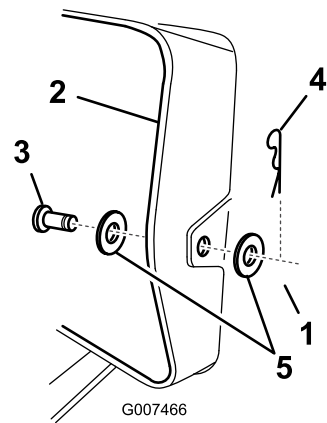

Figure 16

1. Rear plate
2. Discharge tube
3. Clevis pin
4. Hair pin
5. Washers

8. Remove the nut and outer washer that secure the discharge chute to the discharge tube (Figure 17).

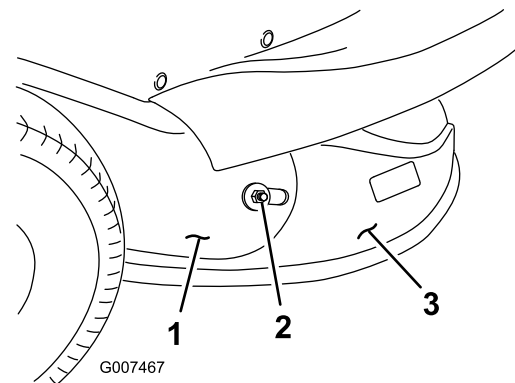

Figure 17

1. Discharge tube
2. Nut and outer washer
3. Discharge chute

9. Move the height-of-cut lever to the lowest position.
10. Remove the bolt, washer, and nut that secure the 2 strap ends together (Figure 18).

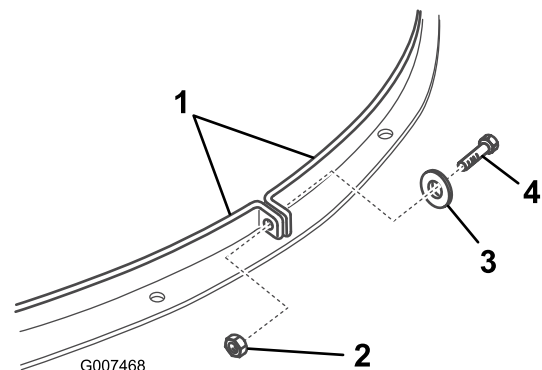

Figure 18

1. Straps
2. Nut
3. Washer
4. Bolt

11. Move the straps away from the discharge chute.

Note: Do not remove the straps from the mower housing. If a strap comes off the housing, insert it as shown in (Figure 19).

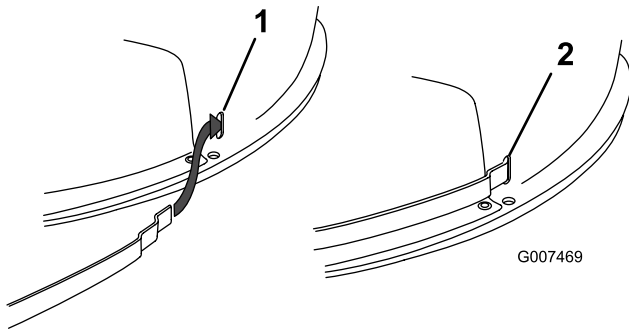

Figure 19

1. Inserting the strap into the slot
2. The strap is inserted into the slot

12. Remove the discharge chute from the mower housing.

Note: Attach the nut and outer washer that you removed to the discharge chute to prevent losing them.

13. Install the Recycler cover onto the mower.

14. Join the 2 strap ends around the Recycler cover as shown (Figure 18).

15. Align the holes in the strap ends and fasten them together snugly with the bolt, washer, and nut you previously removed.

16. Raise the grass collector and install the clevis pin, 2 washers, and hairpin to secure the discharge tube to the rear plate (Figure 19).

Installing the Discharge Chute



Without the grass deflector, discharge cover, or complete grass catcher assembly mounted in place, you and others are exposed to blade contact and thrown debris. Contact with the rotating mower blade and thrown debris will cause injury or death.

- Never remove the grass deflector from the mower because the grass deflector routes material down toward the turf. If the grass deflector is ever damaged, replace it immediately.
- Never put your hands or feet under the mower.
- Never try to clear the discharge area or mower blades unless you disengage the power take-off (PTO) and turn the ignition key to Off. Also remove the key and disconnect the wire from the spark plug.

1. Park the machine on a level surface.
2. Disengage the blade (PTO).
3. Shift the ground speed lever into Neutral (model 70185 only).
4. Set the parking brake.
5. Stop the engine and wait for all moving parts to stop.
6. Remove the ignition key.
7. Raise the grass collector and remove the hairpin and clevis pin that secure the discharge tube to the rear plate (Figure 16).
8. Move the height of cut lever to the lowest position.
9. Remove the bolt, washer, and nut that secure the 2 strap ends together (Figure 18).
10. Move the straps away from the the discharge chute.

Note: Do not remove the straps from the mower housing.

11. Remove the Recycler cover from the mower housing.
12. Install the discharge chute onto the mower.
13. Raise the grass collector and install the clevis pin and hairpin to secure the discharge tube to the rear plate (Figure 16).
14. Install the nut and outer washer that secure the discharge chute to the discharge tube (Figure 17).

15. Join the 2 strap ends around the discharge chute as shown in Figure 18.
16. Align the holes in the strap ends and fasten them together snugly with the bolt, washer, and nut you previously removed (Figure 18).

shredding the grass blades. Tearing and shredding the grass turns it brown at the edges, which slows its growth and increases the chance of disease. Every 30 days, check the blade for sharpness and file down any nicks.

Operating Tips

- For the best performance, operate the engine at the maximum speed. The mower requires air to thoroughly cut grass clippings, so do not set the height-of-cut too low or completely surround the mower in uncut grass. Always leave one side of the mower free from uncut grass to allow the air to be drawn into the mower.
- Cut the grass slightly longer than normal to ensure that the cutting height of the mower does not scalp any uneven ground. When cutting grass longer than 15 cm tall, cut the lawn twice to ensure an acceptable appearance.
- It is best to cut only about 1/3 of the grass blade. Do not cut more than that unless the grass is sparse or it is late fall when grass grows more slowly.
- Alternate the mowing direction to keep the grass standing straight. This also helps disperse clippings and enhances decomposition and fertilization.
- Grass grows at different rates at different times of the season. To maintain the same cutting height, which is a good practice, mow more often in early spring. As the grass growth rate slows in mid summer, mow less frequently.
- If the grass is longer than normal, or if it contains a high degree of moisture, raise the cutting height higher than usual, cut the grass at that setting, and then cut the grass again at the lower, normal setting.
- If you must stop the machine while mowing, you may leave a clump of grass clippings on your lawn. To avoid this, do the following:
 - Engage the blade and move to a previously cut area.
 - Disperse the clippings evenly by raising the mower 1 or 2 height-of-cut settings while driving forward with the blade engaged.
- Use the washout port to clean clippings and dirt from the underside of the mower after each use. If grass and dirt build up inside the mower, the cutting quality will eventually become unsatisfactory.
- Maintain a sharp blade throughout the season. A sharp blade cuts grass cleanly without tearing or

Maintenance

Recommended Maintenance Schedule(s)

Maintenance Service Interval	Maintenance Procedure
After the first 5 hours	<ul style="list-style-type: none"> • Change the oil.
Before each use or daily	<ul style="list-style-type: none"> • Check the oil level.
Every 25 hours	<ul style="list-style-type: none"> • Grease the machine with a general-purpose grease. • Clean the foam element. • Check the spark plug.
Every 50 hours	<ul style="list-style-type: none"> • Change the oil.
Every 100 hours	<ul style="list-style-type: none"> • Replace the paper element. • Replace the spark plug. • Replace the fuel filter.
Before storage	<ul style="list-style-type: none"> • Charge the battery.



If you leave the key in the ignition switch, someone could accidentally start the engine and seriously injure you or other bystanders.

Remove the key from the ignition and disconnect the wire from the spark plug before you do any maintenance. Set the wire aside so that it does not accidentally contact the spark plug.

Lubrication

Greasing and Lubricating the Machine

Service Interval: Every 25 hours

1. Disengage the blade (PTO).
2. Shift the ground speed lever into Neutral (model 70185 only).
3. Set the parking brake.
4. Stop the engine and wait for all moving parts to stop.
5. Remove the ignition key.
6. Lubricate the front wheels.
7. Wipe up any excess grease.

Engine Maintenance

Servicing the Engine Oil

Oil Type: Detergent oil (API service SF, SG, SH, SJ, or higher)

Crankcase Capacity: 1400 cc/1.4 l

Viscosity: See the table below.

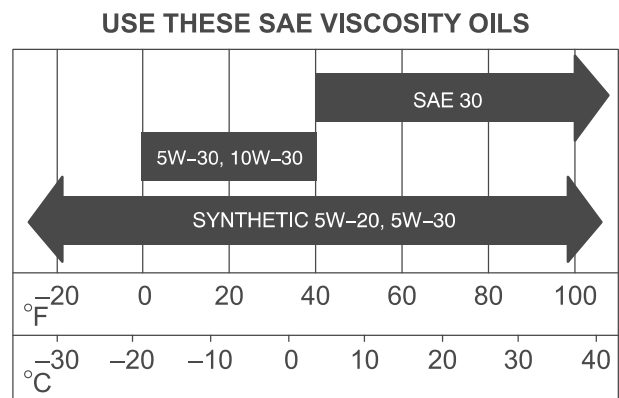

Figure 20

G007480

Checking the Oil Level

Service Interval: Before each use or daily

1. Park the machine on a level surface.
2. Disengage the blade (PTO).
3. Shift the ground speed lever into Neutral (model 70185 only).
4. Set the parking brake.
5. Stop the engine and wait for all moving parts to stop.
6. Remove the ignition key.
7. Raise the seat.
8. Clean around the oil dipstick (Figure 21) so that dirt cannot fall into the fill tube and damage the engine.

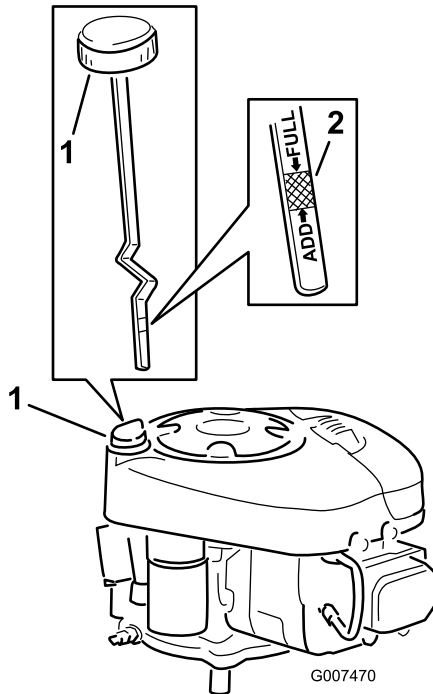

Figure 21

1. Oil dipstick/ fill tube
2. Metal end

9. Unscrew the oil dipstick and wipe the metal end clean (Figure 21).
10. Screw the oil dipstick fully onto the fill tube (Figure 21). Unscrew the dipstick again and look at the metal end. If the oil level is low, slowly pour only enough oil into the fill tube to raise the level to the Full mark on the dipstick.

Important: Do not overfill the crankcase with oil and run the engine; engine damage may result.

Changing the Oil

Service Interval: After the first 5 hours

Every 50 hours

1. Start the engine and let it run for 5 minutes.
Note: This warms the oil so that it drains better.
2. Park the machine so that the right front side is slightly lower than the left side to ensure that the oil drains completely.
3. Disengage the blade (PTO).
4. Shift the ground speed lever into Neutral. (model 70185 only).
5. Set the parking brake.
6. Stop the engine and wait for all moving parts to stop.
7. Remove the ignition key.
8. Raise the seat.
9. Insert the draining tube onto the oil drain valve (Figure 22).

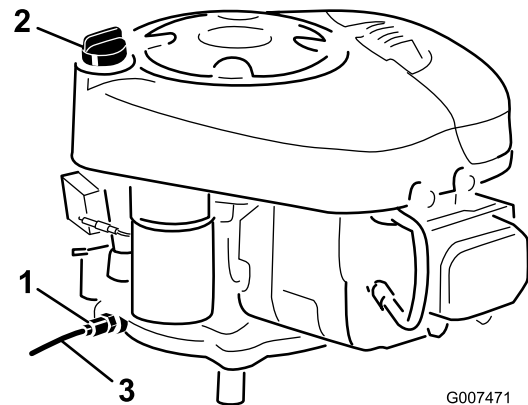

Figure 22

1. Oil drain valve
2. Oil dipstick/fill tube
3. Draining tube

10. Place a pan below the draining tube.
11. Open the oil drain valve (Figure 22).
12. When the oil has drained completely, remove the draining tube and close the oil drain valve.

Note: Dispose of the used oil at a certified recycling center.

13. Slowly pour approximately 80% of the specified amount of oil into the fill tube (Figure 21). Check the oil level; refer to steps 9 and 10 of Checking the Oil Level.

Servicing the Air Cleaner

Service Interval: Every 25 hours
Every 100 hours

Removing the Foam and Paper Elements

1. Set the parking brake, stop the engine, and remove the ignition key.
2. Clean around the air cleaner to prevent dirt from getting into the engine and causing damage (Figure 23).

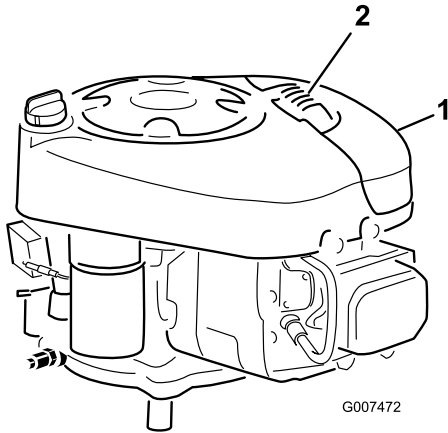

Figure 23

1. Air cleaner cover
2. Air cleaner cover handle

3. Pull up on the air cleaner cover handle and rotate it toward the engine (Figure 23).
4. Remove the air cleaner cover.
5. Carefully slide the paper element and foam element from the blower housing (Figure 24).

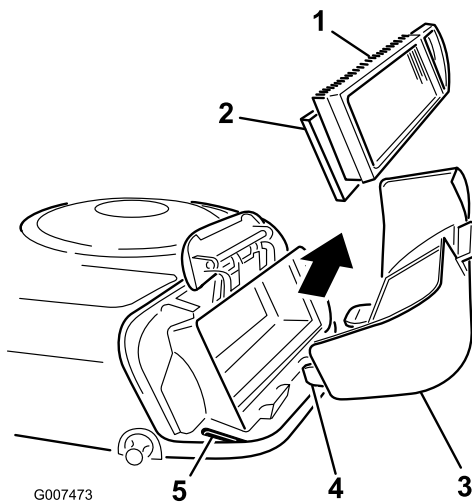

Figure 24

1. Paper element
2. Foam element
3. Air cleaner cover
4. Tab
5. Slot

Cleaning the Foam and Paper Elements

Foam Element:

1. Wash the foam element in liquid soap and warm water. When the element is clean, rinse it thoroughly.
2. Dry the element by squeezing it in a clean cloth. **Do not oil the element.**

Important: Replace the foam element if it is torn or worn.

Paper Element:

1. Lightly tap the element on a flat surface to remove dust and dirt.
2. Carefully clean the rubber seal on the paper element to prevent debris from entering the engine.
3. Inspect the element for tears, an oily film, and damage to the rubber seal.

Important: Never clean the paper element with pressurized air or liquids, such as solvent, gasoline, or kerosene. Replace the paper element if it is damaged or cannot be cleaned thoroughly.

Installing the Foam and Paper Elements

Important: To prevent engine damage, always operate the engine with the complete foam and paper air cleaner assembly installed.

1. Place the foam element and paper element into the blower housing.

Note: Ensure that the rubber seal is flat against the air cleaner base.

2. Align the tabs on the air cleaner cover with the slots of the blower housing (Figure 24).
3. Hook the handle onto the cover and press down on the handle to lock the cover in place.

Servicing the Spark Plug

Service Interval: Every 25 hours
Every 100 hours

Install a new Champion RJ-19LM or equivalent spark plug. Ensure that the air gap between the center and side electrodes is 0.76 mm before installing the spark plug. Use a spark plug wrench for removing and installing the spark plug and a gapping tool or feeler gauge to check and adjust the air gap.

Removing the Spark Plug

1. Disengage the blade (PTO).
2. Shift the ground speed into Neutral (model 70185 only).
3. Set the parking brake.
4. Stop the engine and wait for all moving parts to stop.
5. Remove the ignition key.
6. Reach under the body of the machine above the left rear wheel and disconnect the wire from the spark plug (Figure 25).

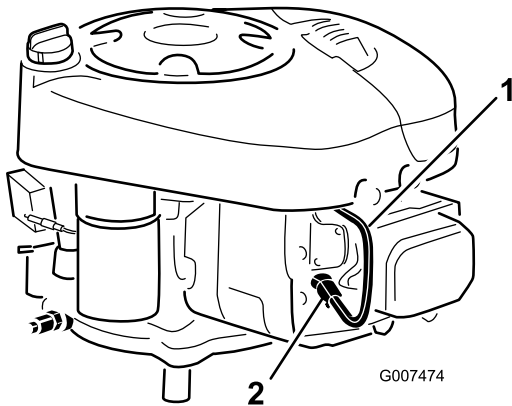

Figure 25

1. Spark-plug wire
2. Spark plug

7. Clean around the spark plug to prevent dirt from falling into the engine and potentially causing damage.
8. Remove the spark plug and metal washer.

Checking the Spark Plug

1. Look at the center of the spark plug (Figure 26). If you see light brown or gray on the insulator, the engine is operating properly. A black coating on the insulator usually means that the air cleaner is dirty.

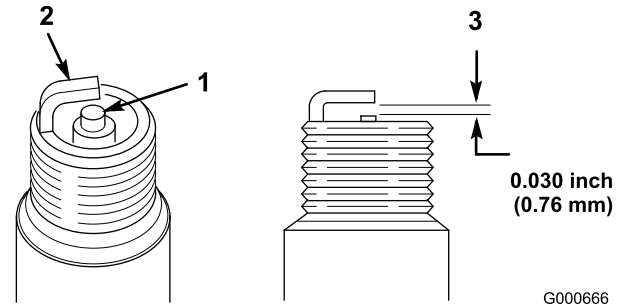

Figure 26

1. Center electrode insulator
2. Side electrode
3. Air gap (not to scale)

Important: Do not clean the spark plug. Always replace the spark plug when it has a black coating, worn electrodes, an oily film, or cracks.

2. Check the gap between the center and side electrodes (Figure 26) and bend the side electrode if the gap is not correct.

Installing the Spark Plug

1. Install the spark plug and metal washer.
Note: Ensure that the air gap is set correctly.
2. Tighten the spark plug to 20 N·m.
3. Connect the wire to the spark plug (Figure 25).

Fuel System Maintenance

Draining the Fuel Tank



In certain conditions, gasoline is extremely flammable and highly explosive. A fire or explosion from gasoline can burn you and others and can damage property.

- Drain gasoline from the fuel tank when the engine is cold. Do this outdoors in an open area. Wipe up any gasoline that spills.
- Never smoke when draining gasoline, and stay away from an open flame or where a spark may ignite the gasoline fumes.

1. Park the machine so that the left front side is slightly lower than the right side to ensure that the fuel tank drains completely.
2. Disengage the blade (PTO).
3. Shift the ground speed lever into Neutral (model 70185 only).
4. Set the parking brake.
5. Stop the engine.
6. Remove the ignition key.
7. Remove the engine cover.
8. Squeeze the ends of the hose clamp together and slide it up the fuel line toward the fuel tank (Figure 27).

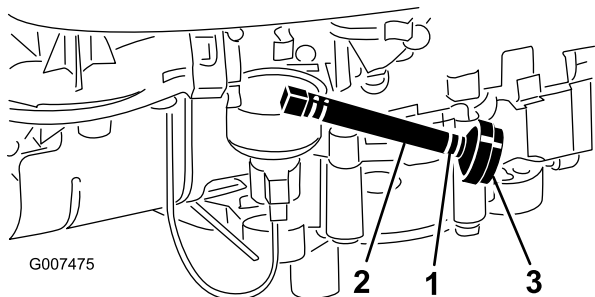

Figure 27

1. Hose clamp
2. Fuel line
3. Filter

9. Pull the fuel line off the filter (Figure 27) and allow the gasoline to drain into a gas can or drain pan.

Note: Now is the best time to install a new fuel filter because the fuel tank is empty.

10. Install the fuel line onto the filter.
11. Slide the hose clamp close to the filter to secure the fuel line and filter.
12. Install the engine cover.

Replacing the Fuel Filter

Service Interval: Every 100 hours

Note: The best time to replace the fuel filter (Figure 27) is when the fuel tank is empty. Never install a dirty filter if it is removed from the fuel line.

1. Disengage the blade (PTO).
2. Shift the ground speed lever into Neutral (model 70185 only).
3. Set the parking brake.
4. Stop the engine.
5. Remove the ignition key.
6. Remove the engine cover.
7. Squeeze the ends of the hose clamps together and slide them away from the filter (Figure 27).
8. Remove the filter from the fuel lines.
9. Install a new filter and move the hose clamps close to the filter.
10. Install the engine cover.

Electrical System Maintenance

Servicing the Battery

Always keep the battery clean and fully charged. Use a paper towel to clean the battery and battery box. If the battery terminals are corroded, clean them with a solution of 4 parts water and 1 part baking soda. Apply a light coating of grease to the battery terminals to prevent corrosion.

Battery voltage and amperage: 12 volts, 155 cold-cranking amps

Removing the Battery



Battery terminals or metal tools could short against metal machine components, causing sparks. Sparks can cause the battery gasses to explode, resulting in personal injury.

- **When removing or installing the battery, do not allow the battery terminals to touch any metal parts of the machine.**
- **Do not allow metal tools to short between the battery terminals and metal parts of the machine.**

1. Disengage the blade (PTO).
2. Shift the ground speed lever into Neutral.
3. Set the parking brake.
4. Stop the engine and wait for all moving parts to stop.
5. Remove the ignition key.
6. Remove the engine cover.
7. Disconnect the negative (black) ground cable from the battery post.



Incorrect battery cable routing could damage the machine and cables, causing sparks. Sparks can cause the battery gasses to explode, resulting in personal injury.

- **Always disconnect the negative (black) battery cable before disconnecting the positive (red) cable.**
- **Always connect the positive (red) battery cable before connecting the negative (black) cable.**

8. Slide the rubber cover up the positive (red) cable.
9. Disconnect the positive (red) cable from the battery post.
10. Remove the battery from the battery box.

Installing the Battery

1. Put the battery into the battery box in the chassis.
2. Using the bolt, washers, and nut, connect the positive (red) cable to the positive (+) battery post.
3. Slide the rubber cover over the battery post.
4. Using the bolt, washers, and nut, connect the negative (black) cable to the negative (-) battery post.
5. Install the engine cover.

Checking the Electrolyte Level

1. Remove the engine cover.
2. Look at the side of the battery. The electrolyte must be up to the upper line (Figure 28).

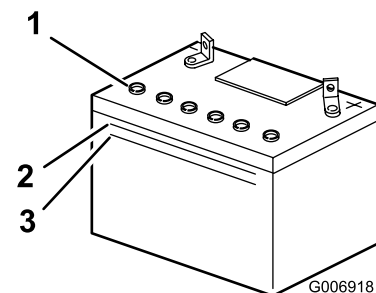

Figure 28

1. Vent caps
2. Upper line
3. Lower line

Note: Do not allow the electrolyte to fall below the lower line (Figure 28).

3. If the electrolyte is low, add the required amount of distilled water; refer to Adding Water to the Battery.



Battery electrolyte contains sulfuric acid, a deadly poison that can severely burn you and others.

- Do not drink electrolyte and avoid contact with skin, eyes or clothing. Wear safety glasses to shield your eyes and rubber gloves to protect your hands.
- Fill the battery where clean water is always available for flushing the skin.

Adding Water to the Battery

The best time to add distilled water to the battery is just before you operate the machine. This lets the water mix thoroughly with the electrolyte solution.

1. Remove the battery from the machine; refer to Removing the Battery.
2. Clean the top of the battery with a paper towel.

Important: Never fill the battery with distilled water while the battery is installed in the machine. Electrolyte could be spilled on other parts and cause corrosion.

3. Remove the vent caps from the battery (Figure 28).
4. Slowly pour distilled water into each battery cell until the electrolyte level is up to the Upper line (Fig. 19) on the battery case.

Important: Do not overfill the battery because electrolyte (sulfuric acid) can cause severe corrosion and damage to the chassis.

5. Wait 5 to 10 minutes after filling the battery cells. Add distilled water, if necessary, until the electrolyte level is up to the Upper line (Figure 28) on the battery case.
6. Install the battery vent caps.

Charging the Battery

Service Interval: Before storage



Charging the battery produces gasses that can explode.

Never smoke near the battery and keep sparks and flames away from battery.

Important: Always keep the battery fully charged (1.260 specific gravity). This is especially important to prevent battery damage when the temperature is below 32°F (0°C).

1. Remove the battery from the chassis; refer to Removing the Battery.
2. Check the electrolyte level; refer to Checking the Electrolyte Level.
3. Ensure that the vent caps are installed in the battery. Charge the battery for 1 hour at 25 to 30 amps or 6 hours at 4 to 6 amps. Do not overcharge the battery.
4. When the battery is fully charged, unplug the charger from the electrical outlet.
5. Disconnect the charger leads from the battery posts (Figure 29).

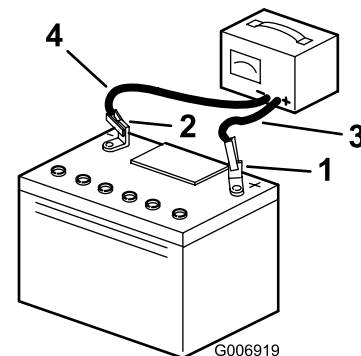

Figure 29

- | | |
|--------------------------|---------------------------|
| 1. Positive battery post | 3. Red (+) charger lead |
| 2. Negative battery post | 4. Black (-) charger lead |

6. Install the battery in the machine and connect the battery cables; refer to Installing the Battery.

Note: Do not run the machine with the battery disconnected; electrical damage may occur.

Servicing the Fuses

The electrical system is protected by 7.5 amp, blade-type fuses. No maintenance is required, however, if a fuse blows, check the circuit wiring for a short.

1. Pull out the fuse (Figure 30) to remove it from the socket.

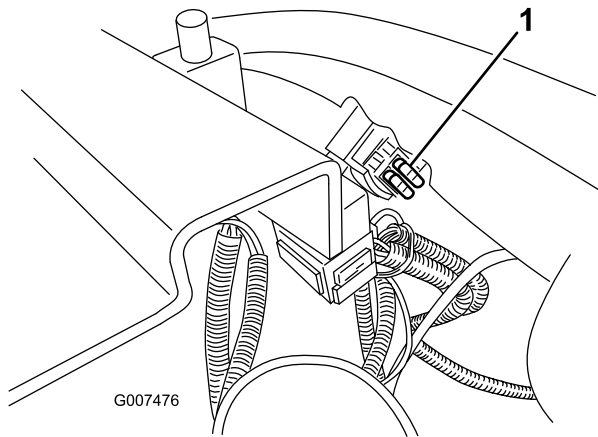

Figure 30

1. Fuses (under the seat)

-
2. Push down on the fuse to insert it.

Brake Maintenance

Checking the Parking Brake

Always set the parking brake when you stop the machine or leave it unattended. Check the parking brake daily to ensure that it holds securely.

1. Park the machine on a level surface.
2. Disengage the blade (PTO).
3. Set the parking brake.
4. Stop the engine and wait for all moving parts to stop.
5. Remove the ignition key.
6. If the rear wheels lock and skid when you try to push the machine forward, you do not need to adjust the parking brake. But if the rear wheels turn and do not lock, you need to have an Authorized Service Dealer adjust the parking brake.

Checking the Tire Pressure

Maintain the air pressure in the tires at 80 kPa. Check the tire pressure after each use. Check the tires when they are cold to get the most accurate pressure reading.

Servicing the Blade

To ensure a superior quality of cut, keep the blade sharp. For convenient sharpening and replacement, you may want to have an extra blade.



A worn or damaged blade can break, and a piece of the blade could be thrown into the operator's or bystander's area, resulting in serious personal injury or death.

- Inspect the blade periodically for wear or damage.
- Replace a worn or damaged blade.

Inspecting the Blade

1. Inspect the cutting edges (Figure 31). If the edges are not sharp or have nicks, remove the blade and sharpen them; refer to Sharpening the Blade.

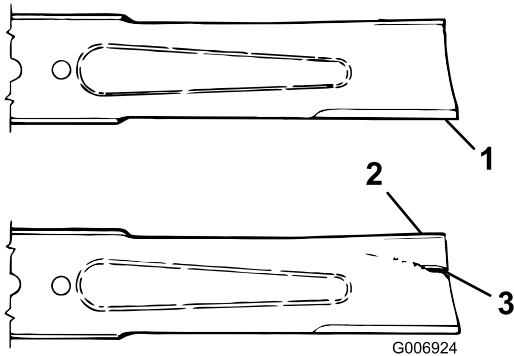

Figure 31

- 1. Cutting edge
- 2. Curved area
- 3. Wear/slot forming

2. Inspect the blade, especially the curved area (Figure 31). If you notice any damage, wear, or a slot forming in this area, immediately install a new blade.

Removing the Blade

1. Stop the engine and wait for all moving parts to stop.
2. Remove the ignition key.
3. Disconnect the wire from the spark plug.

4. Shift the transaxle into first gear.
5. Set the parking brake.
6. Grasp the end of the blade using a rag or thickly padded glove. Then remove the blade bolt, curved washer, blade stiffener, and blade (Figure 32). A block of wood may be wedged between the blade and the mower to lock the blade when you are removing the bolt.

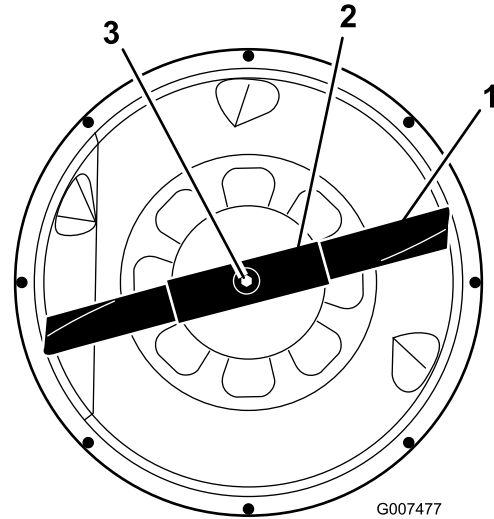

Figure 32

- 1. Blade
- 2. Blade stiffener
- 3. Blade bolt and curved washer

Sharpening the Blade

1. Use a file to sharpen the cutting edge at both ends of the blade (Figure 33). Maintain the original angle. The blade retains its balance if the same amount of material is removed from both cutting edges.

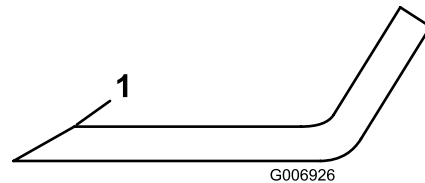

Figure 33

1. Sharpen at original angle
2. Check the balance of the blade by putting it on a blade balancer (Figure 34). If the blade stays in a horizontal position, the blade is balanced and can be used. If the blade is not balanced, file some metal off of the back side of the blade. Repeat this step until the blade is balanced.

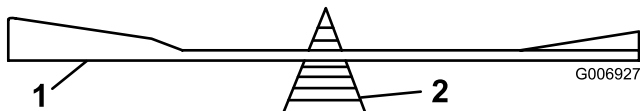

Figure 34

1. Blade
2. Balancer

Installing the Blade

1. Install the blade, blade stiffener, curved washer, and blade bolt (Figure 32).

Important: The curved part of the blade must be pointing toward the inside of the mower to ensure proper cutting.

2. Tighten the blade bolt to 61 to 82 N·m.

Important: Ensure that the cutting edge of the blade is away from the mower housing.

Leveling the Mower

1. If the mower cuts unevenly and the cutting blade is not bent, you must level the mower.
2. Set the parking brake.
3. Stop the engine and wait for all moving parts to stop.
4. Remove the ignition key.
5. Disconnect the wire from the spark plug.
6. Set the air pressure in the tires to the recommended level; refer to Checking the Tire Pressure.
7. Remove the cotter pin at the front of the adjusting rod (Figure 35).

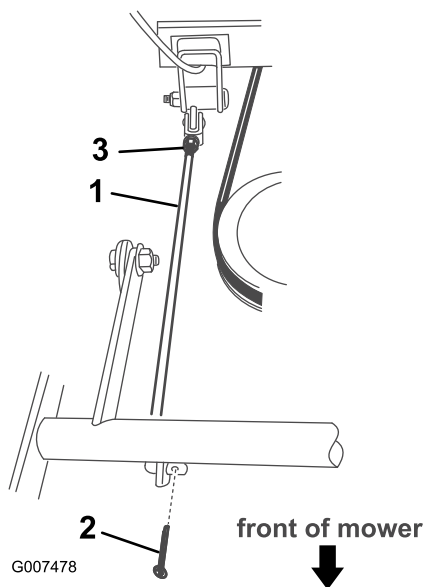

Figure 35

1. Adjusting rod
2. Cotter pin
3. Nut

8. Loosen the nut at the rear of the adjusting rod (Figure 35).

Important: Ensure that the cutting edge of the blade is away from the mower housing.

9. Turn the adjusting rod to the desired level.
10. Tighten the nut.
11. Install the cotter pin.

Cleaning

Washing under the Mower

1. Park the machine on a hard level surface.
2. Disengage the blade (PTO).
3. Stop the engine and wait for all moving parts to stop.
4. Remove the ignition key.
5. Attach the hose coupling to the end of the mower washout fitting and turn the water on high (Figure 36).

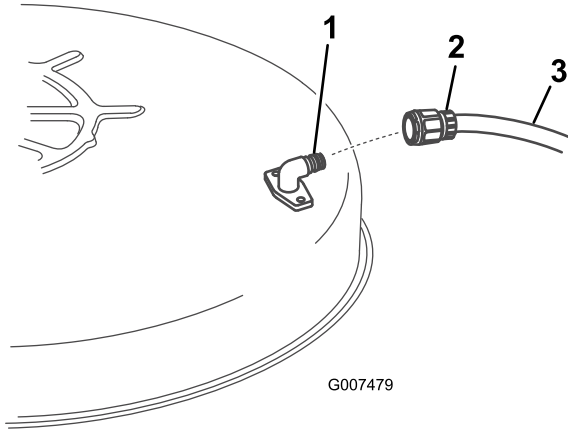

Figure 36

1. Washout port
2. Coupling
3. Hose

Note: Spread petroleum jelly on the washout fitting o-ring to make the coupling slide on easier and to protect the o-ring.

6. Set the mower to the second height-of-cut (B) level.
7. Sit on the seat and start the engine.
8. Engage the blade (PTO) and let the mower run for 1 to 3 minutes.
9. Disengage the blade (PTO).
10. Stop the engine and wait for all moving parts to stop.
11. Remove the ignition key.
12. Shut off the water and remove the coupling from the washout fitting.

Note: If the mower is not clean after one washing, soak it and let it stand for 30 minutes. Then repeat the process.

13. Run the mower again for 1 to 3 minutes to remove the excess water.



A broken or missing washout fitting could expose you and others to thrown objects or blade contact. Contact with the blade or thrown debris contact may cause injury or death.

- Replace broken or missing washout fitting immediately, before using mower again.
- Plug any holes in mower with bolts and locknuts.
- Never put your hands or feet under the mower or through openings in the mower.

Washing the Machine

1. Stop the engine and wait for all moving parts to stop.
2. Remove the ignition key.
3. Wait 10 to 15 minutes for the engine to cool down.
4. Wash the machine with mild detergent and water.

Important: Do not use a pressure washer to wash the machine. Pressure washing may damage the electrical system or wash away necessary grease at friction points. Avoid excessive use of water, especially near the control panel, lights, engine, and battery.

5. Start the engine to dry it off.

Storage

Cleaning and Storage

1. Disengage the blade (PTO).
2. Set the parking brake.
3. Stop the engine and wait for all moving parts to stop.
4. Remove the ignition key.
5. Remove grass clippings, dirt, and grime from the external parts of the entire machine, especially the engine. Clean the dirt and chaff from the outside of the engine cylinder head fins and blower housing.

Important: You can wash the machine with mild detergent and water. Do not use a pressure washer to wash the machine. Pressure washing may damage the electrical system or wash away necessary grease at friction points. Avoid excessive use of water, especially near the control panel, lights, engine, and battery.

6. Check the parking brake; refer to Checking the Parking Brake.
7. Service the air cleaner; refer to Servicing the Air Cleaner.
8. Change the engine oil; refer to Servicing the Engine Oil.
9. Check the tire pressure; refer to Checking the Tire Pressure.
10. When storing the machine for over 30 days, prepare it as follows:
 - A. Add a petroleum based stabilizer/conditioner to the fuel in the tank according to the instructions from the stabilizer manufacturer. **Do not use an alcohol based stabilizer (ethanol or methanol).**

Note: A fuel stabilizer/conditioner is most effective when mixed with fresh gasoline and used at all times.

 - B. Run the engine for 5 minutes to distribute conditioned fuel through the fuel system.
 - C. Stop the engine, allow it to cool, and drain the fuel tank; refer to Draining the Fuel Tank.
 - D. Start the engine and run it until it stops.
 - E. Choke or prime the engine.
 - F. Start and run the engine until it will not start again.
 - G. Recycle the old fuel according to local codes.

Important: Do not store stabilizer/conditioned gasoline over 90 days.

11. Remove and inspect the spark plug; refer to Servicing the Spark Plug. With the spark plug removed from the engine, pour 2 tablespoons of engine oil into the spark plug hole. Use the electric starter to crank the engine and distribute the oil inside the cylinder. Install the spark plug, but do not connect the wire to the spark plug.
 12. Disconnect the negative battery cable. Clean the battery and battery terminals. Check the electrolyte level and charge it fully; refer to Servicing the Battery. Leave the negative battery cable disconnected from the battery during storage.
- Important:** The battery must be fully charged to prevent it from freezing and being damaged at temperatures below 32°F (0°C). You can store a fully charged battery during the winter without recharging.
13. Check and tighten all bolts, nuts, and screws. Repair or replace any part that is worn or damaged.
 14. Paint all scratched or bare metal surfaces with paint available from an Authorized Service Dealer.
 15. Store the machine in a clean, dry garage or storage area. Remove the ignition and KeyChoice keys from the mower and keep them in a memorable place. Cover the machine to protect it and keep it clean.

Troubleshooting

Problem	Possible Cause	Corrective Action
The starter does not crank.	<ol style="list-style-type: none"> 1. The blade control (PTO) is engaged. 2. The parking brake is not engaged. 3. The battery is dead. 4. The electrical connections are corroded or loose. 5. A fuse is blown. 6. A relay or switch is damaged. 	<ol style="list-style-type: none"> 1. Disengage the blade (PTO). 2. Set the parking brake. 3. Charge the battery. 4. Check the electrical connections for good contact. 5. Replace the fuse. 6. Contact an Authorized Service Dealer.
The engine will not start, starts hard, or fails to keep running.	<ol style="list-style-type: none"> 1. The operator is not seated. 2. The fuel tank is empty. 3. The air cleaner is dirty. 4. The spark plug wire is loose or disconnected. 5. The spark plug is pitted, fouled, or the gap is incorrect. 6. The choke is not closing. 7. There is dirt in the fuel filter. 8. The idle speed is too low or the mixture is incorrect. 9. Dirt, water, or stale fuel is in the fuel system. 10. The engine is flooded. 11. The battery is dead. 	<ol style="list-style-type: none"> 1. Sit on the seat. 2. Fill the fuel tank with gasoline. 3. Clean or replace the air cleaner element. 4. Connect the wire to the spark plug. 5. Install a new, correctly-gapped spark plug. 6. Adjust the throttle cable. 7. Replace the fuel filter. 8. Adjust the carburetor idle speed and idle mixture. 9. Contact an Authorized Service Dealer. 10. Remove the spark plug and dry it out. 11. Charge the battery.
The engine loses power.	<ol style="list-style-type: none"> 1. The engine load is excessive. 2. The air cleaner element is dirty. 3. The oil level in the crankcase is low. 4. The cooling fins and air passages under the engine blower housing are plugged. 5. The spark plug is pitted, fouled, or the gap is incorrect. 6. There is dirt in the fuel filter. 7. Dirt, water, or stale fuel is in the fuel system. 	<ol style="list-style-type: none"> 1. Shift into a lower gear to reduce the ground speed. 2. Clean the air cleaner element. 3. Add oil to the crankcase. 4. Remove the obstruction from the cooling fins and air passages. 5. Install a new, correctly-gapped spark plug. 6. Replace the fuel filter. 7. Contact an Authorized Service Dealer.
The engine overheats.	<ol style="list-style-type: none"> 1. The engine load is excessive. 2. The oil level in the crankcase is low. 3. The cooling fins and air passages under the engine blower housing are plugged. 	<ol style="list-style-type: none"> 1. Shift into a lower gear to reduce the ground speed. 2. Add oil to the crankcase. 3. Remove the obstruction from the cooling fins and air passages.
There is an abnormal vibration.	<ol style="list-style-type: none"> 1. The blade is bent or unbalanced. 2. The blade mounting bolt is loose. 3. The engine mounting bolts are loose. 4. There is a loose engine pulley, idler pulley, or blade pulley. 5. The engine pulley is damaged. 	<ol style="list-style-type: none"> 1. Install a new blade. 2. Tighten the blade mounting bolt. 3. Tighten the engine mounting bolts. 4. Tighten the appropriate pulley. 5. Contact an Authorized Service Dealer.
The blade does not rotate.	<ol style="list-style-type: none"> 1. The blade drive belt is worn, loose, or broken. 2. The blade drive belt is off of the pulley. 	<ol style="list-style-type: none"> 1. Contact an Authorized Service Dealer. 2. Contact an Authorized Service Dealer.

Problem	Possible Cause	Corrective Action
The machine does not drive.	<ol style="list-style-type: none"> 1. The traction belt is worn, loose, or broken. 2. The traction belt is off the pulley. 3. The transmission does not shift. 	<ol style="list-style-type: none"> 1. Contact an Authorized Service Dealer. 2. Contact an Authorized Service Dealer. 3. Contact an Authorized Service Dealer.
The cutting height is uneven.	<ol style="list-style-type: none"> 1. The tire pressure is incorrect. 2. The mower is not level. 3. The underside of the mower is dirty. 	<ol style="list-style-type: none"> 1. Set the tire pressure. 2. Level the mower. 3. Clean under the mower.
The cutting quality is poor.	<ol style="list-style-type: none"> 1. The cutting blade is worn. 2. The cutting height is incorrect. 	<ol style="list-style-type: none"> 1. Sharpen or replace the cutting blade. 2. Adjust the cutting height.
The grass collector fails to fill.	<ol style="list-style-type: none"> 1. The cutting height is too low. 2. The grass is too heavy or damp. 3. The cutting blade is worn. 4. The grass is too high. 5. The discharge area is blocked. 	<ol style="list-style-type: none"> 1. Raise the cutting height. 2. Wait until the grass has dried. 3. Sharpen or replace the blade. 4. Raise the cutting height. 5. Remove the obstruction from the discharge area.

Schematics

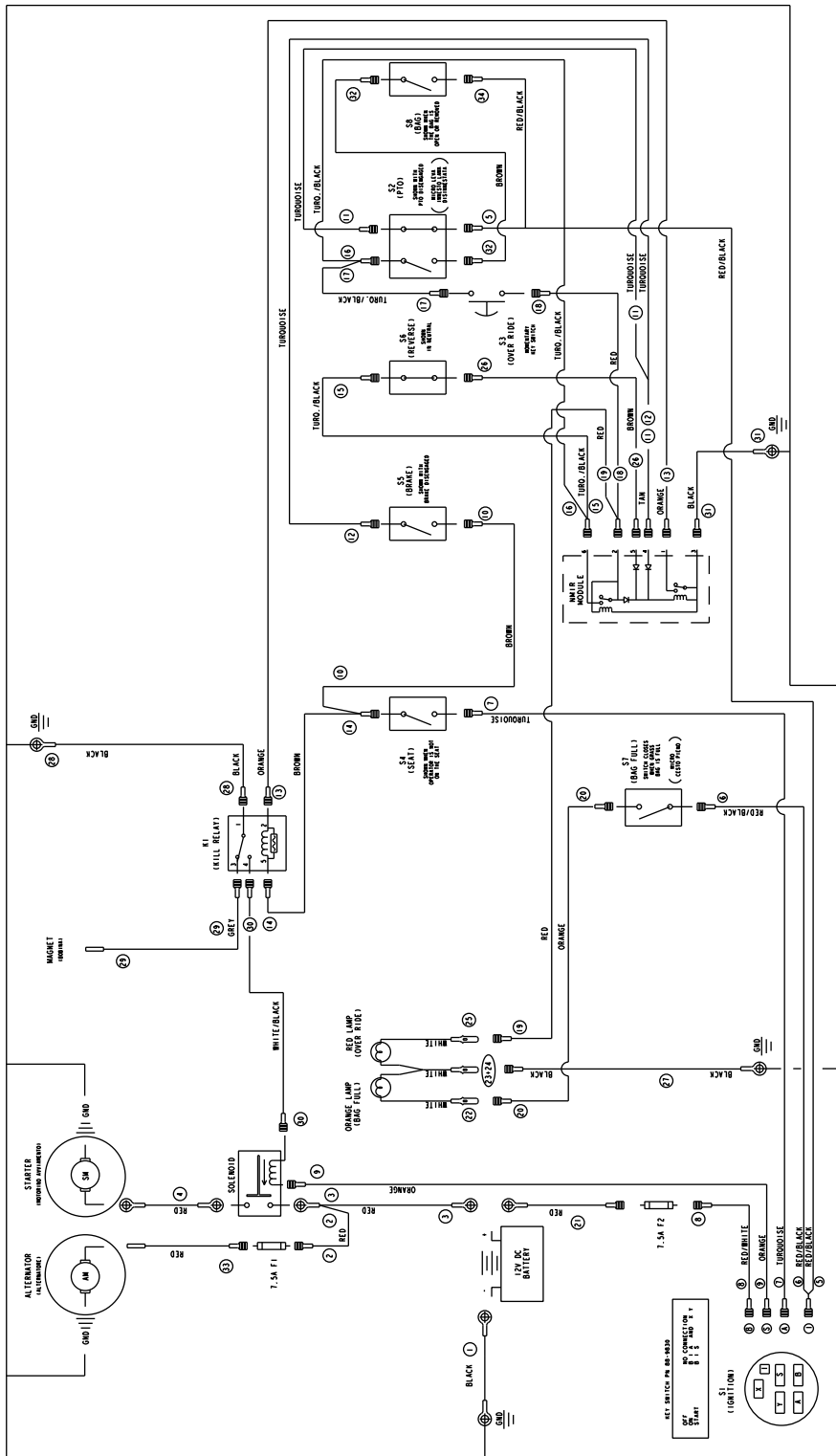

G007482

Model 70185 (Rev. A)

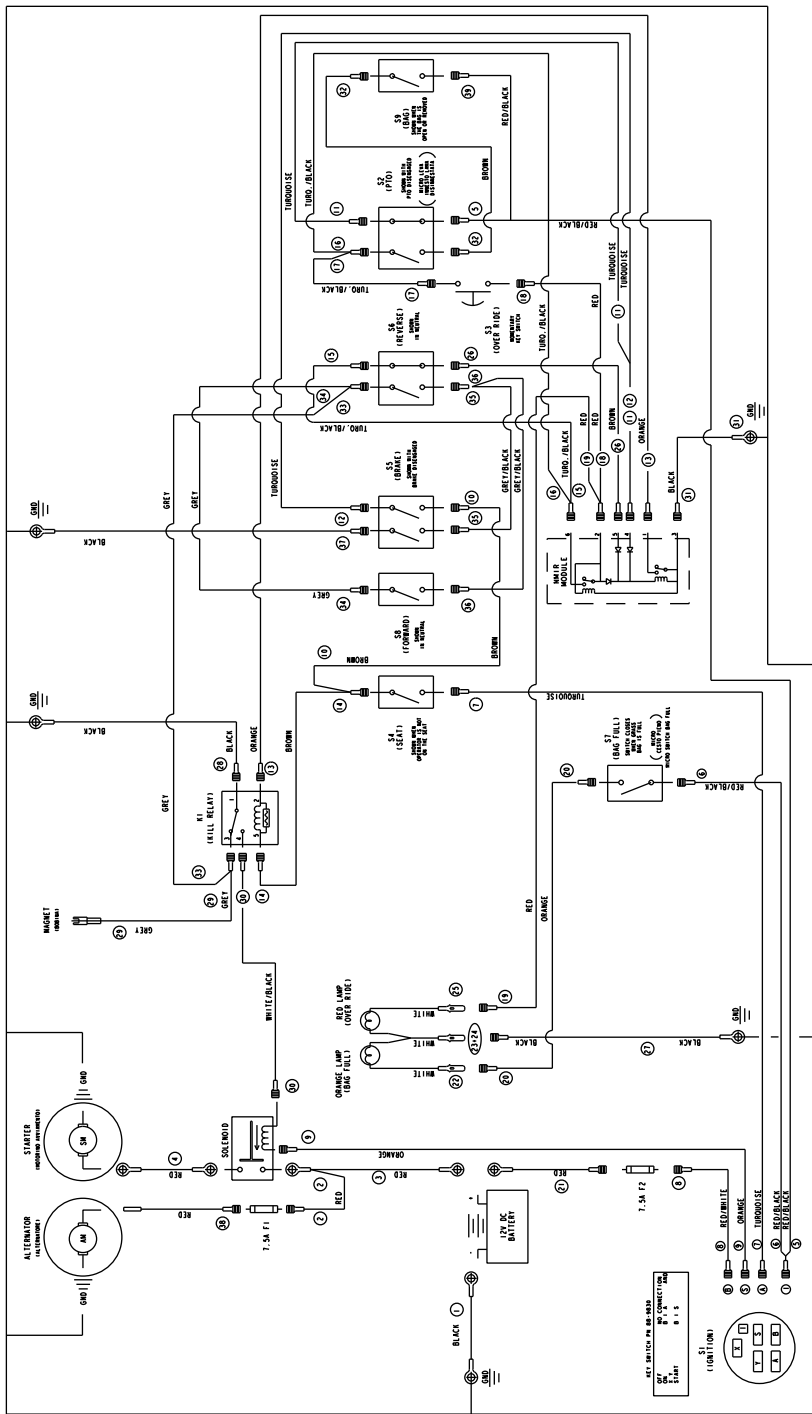

G007586

Model 70186 (Rev. A)

Notes:

Notes:

Notes:

International Distributor List—Consumer Products

Distributor:	Country:	Phone Number:
Atlantis Su ve Sulama Sistemleri Lt	Turkey	90 216 344 86 74
Balama Prima Engineering Equip	Hong Kong	852 2155 2163
B-Ray Corporation	Korea	82 32 551 2076
Casco Sales Company	Puerto Rico	787 788 8383
Ceres S.A	Costa Rica	506 239 1138
CSSC Turf Equipment (pvt) Ltd	Sri Lanka	94 11 2746100
Cyril Johnston & Co	Nothern Ireland	44 2890 813 121
Equivier	Mexico	52 55 539 95444
Femco S.A.	Guatemala	502 442 3277
G.Y.K. Company Ltd.	Japan	81 726 325 861
Geomechaniki of Athens	Greece	30 10 935 0054
Guandong Golden Star	China	86 20 876 51338
Hako Gorund and Garden	Sweden	46 35 10 0000
Hydroturf Int. Co	Dubai United Arab Emirates	97 14 347 9479
Hydroturf Egypt LLC	Egypt	202 519 4308
Ibea S.p.A.	Italy	39 0331 853611
Irriamc	Portugal	351 21 238 8260
Jean Heybroek b.v.	Netherlands	31 30 639 4611
Lely (U.K.) Limited	United Kingdom	44 1480 226 800
Maquiver S.A.	Colombia	57 1 236 4079
Maruyama Mfg. Co. Inc.	Japan	81 3 3252 2285
Metra Kft	Hungary	36 1 326 3880
Mountfield a.s.	Czech Republic	420 255 704 220
Munditol S.A.	Argentina	54 11 4 821 9999
Oslinger Turf Equipment SA	Ecuador	593 4 239 6970
Oy Hako Ground and Garden Ab	Finland	358 987 00733
Parkland Products Ltd	New Zealand	64 3 34 93760
Prochaska & Cie	Austria	43 1 278 5100
RT Cohen 2004 Ltd	Israel	972 986 17979
Riversa	Spain	34 9 52 83 7500
Roth Motorgerate GmBh & Co	Germany	49 7144 2050
Sc Svend Carlsen A/S	Denmark	45 66 109 200
Solvert S.A.S	France	33 1 30 81 77 00
Spypros Stavrinides Limited	Cyprus	357 22 434131
Surge Systems India Limited	India	91 1 292299901
T-Markt Logistics Ltd	Hungary	36 26 525 500
Toro Australia	Australia	61 3 9580 7355
Toro Europe BVBA	Belgium	32 14 562 960



The Toro Warranty

Conditions and Products Covered

The Toro® Company and its affiliate, Toro Warranty Company, pursuant to an agreement between them, jointly promises to the original purchaser* to repair any Toro Product used for normal residential purposes* if defective in materials or workmanship. The following time periods apply from the date of original purchase:

Products	Warranty Period
Walk Power Mowers	2-year limited warranty
Rear Engine Riders	2-year limited warranty
Lawn & Garden Tractors	2-year limited warranty
Electric Hand Held Products	2-year limited warranty
Snowthrowers	2-year limited warranty
Consumer Zero Turn	2-year limited warranty

* "Original purchaser" means use the person who originally purchased Toro products.

* "Normal residential purposes" means use of the product on the same lot as your home. Use at more than one location is considered commercial use, and the commercial use warranty would apply.

Limited Warranty for Commercial Use

Toro Consumer Products and attachments used for commercial, institutional, or rental use are warranted against defects in materials or workmanship for the following time periods from the date of original purchase:

Products	Warranty Period
Walk Power Mowers	90 day warranty
Rear Engine Riders	90 day warranty
Lawn & Garden Tractors	90 day warranty
Electric Hand Held Products	90 day warranty
Snowthrowers	90 day warranty
Consumer Zero Turn	45 day warranty

Instructions for Obtaining Warranty Service

If you think that your Toro Product contains a defect in materials or workmanship, follow this procedure:

1. Contact your seller to arrange service of the product. If for any reason it is impossible for you to contact your seller, you may contact any Toro Authorized Distributor to arrange service.
2. Bring the product and your proof of purchase (sales receipt) to your seller or the Service Dealer.

If for any reason you are dissatisfied with the Service Dealer's analysis or with the assistance provided, contact the Toro importer or contact us at:

Customer Care Department, Consumer Division
Toro Warranty Company
8111 Lyndale Avenue South
Bloomington, MN 55420-1196
Manager: Technical Product Support: 001-952-887-8248

See attached Distributor List

Owner Responsibilities

You must maintain your Toro Product by following the maintenance procedures described in the operator's manual. Such routine maintenance, whether performed by a dealer or by you, is at your expense.

Items and Conditions Not Covered

This express warranty does not cover:

- Cost of regular maintenance service or parts, such as filters, fuel, lubricants, tune-up parts, blade sharpening, brake and clutch adjustments.
- Any product or part which has been altered or misused or required replacement or repair due to normal wear, accidents, or lack of proper maintenance.
- Repairs necessary due to improper fuel, contaminants in the fuel system, or failure to properly prepare the fuel system prior to any period of non-use over three months.
- Engine and transmission. These are covered by the appropriate manufacturer's guarantees with separate terms and conditions.

All repairs covered by this warranty must be performed by an Authorized Toro Service Dealer using Toro approved replacement parts.

General Conditions

The purchaser is covered by the national laws of each country. The rights to which the purchaser is entitled with the support of these laws are not restricted by this warranty.