



**Count on it.**

**Operator's Manual**

**Commercial Walk-Behind Mower  
with Floating Deck, T-Bar, Hydro with 91cm  
TURBO FORCE® Cutting Unit**

Model No. 30032—Serial No. 270000001 and Up

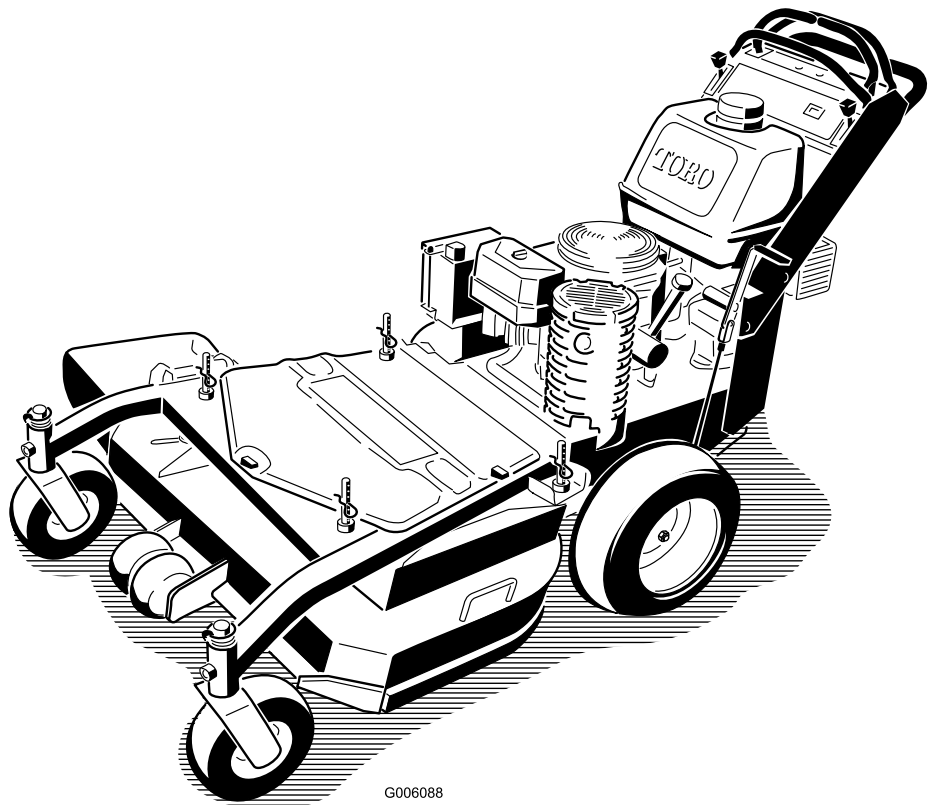

G006088

## Warning

### CALIFORNIA Proposition 65 Warning

The engine exhaust from this product contains chemicals known to the State of California to cause cancer, birth defects, or other reproductive harm.

This spark ignition system complies with Canadian ICES-002.

**Important:** This engine is not equipped with a spark arrester muffler. It is a violation of California Public Resource Code Section 4442 to use or operate the engine on any forest-covered, brush-covered, or grass-covered land. Other states or federal areas may have similar laws.

The enclosed *Engine Owner's Manual* is supplied for information regarding the US Environmental Protection Agency (EPA) and the California Emission Control Regulation of emission systems, maintenance, and warranty. Replacements may be ordered through the engine manufacturer.

## Introduction

Read this information carefully to learn how to operate and maintain your product properly and to avoid injury and product damage. You are responsible for operating the product properly and safely.

You may contact Toro directly at [www.Toro.com](http://www.Toro.com) for product and accessory information, help finding a dealer, or to register your product.

Whenever you need service, genuine Toro parts, or additional information, contact an Authorized Service Dealer or Toro Customer Service and have the model and serial numbers of your product ready. Figure 1 identifies the location of the model and serial numbers on the product. Write the numbers in the space provided.

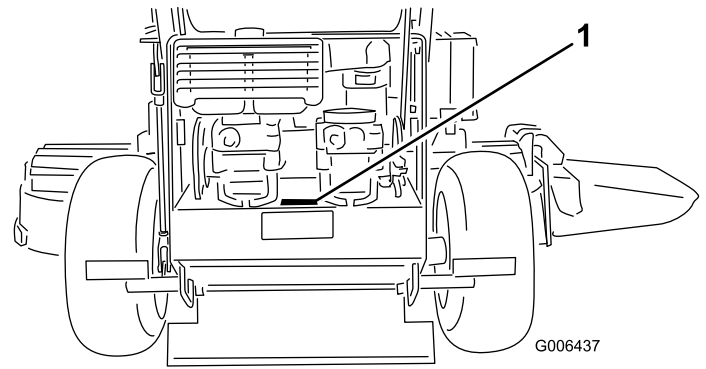

Figure 1

1. Location of the model and serial numbers

Model No. _____
Serial No. _____

This manual identifies potential hazards and has safety messages identified by the safety alert symbol (Figure 2), which signals a hazard that may cause serious injury or death if you do not follow the recommended precautions.



Figure 2

1. Safety alert symbol

This manual uses 2 other words to highlight information. **Important** calls attention to special mechanical information and **Note** emphasizes general information worthy of special attention.

## Contents

Introduction.....	2
Safety .....	4
General Lawn Mower Safety .....	4
Sound Pressure.....	5
Sound Power .....	5
Vibration, Hand/arm .....	6
Slope Chart .....	7
Safety and Instructional Decals .....	8
Product Overview .....	11
Controls .....	11
Specifications .....	12
Operation.....	12
Adding Fuel .....	12
Checking the Engine Oil Level.....	13

Think Safety First.....	13	Mower Deck Maintenance.....	40
Operating the Parking Brake.....	13	Servicing the Cutting Blades.....	40
Starting and Stopping the Engine.....	14	Correcting the Mower Quality of Cut.....	42
Operating the Mower Blade Control (PTO).....	15	Frame Set Up.....	42
The Safety Interlock System.....	15	Checking the Mower Deck Front-to-Rear Pitch.....	44
Driving Forward or Backward.....	16	Changing the Mower Deck Front-to-Rear Pitch.....	44
Stopping the Machine.....	16	Checking the Mower Deck Side-to-Side Height.....	45
Pushing the Machine by Hand.....	17	Changing the Mower Deck Side-to-Side Height.....	45
Transporting Machines.....	17	Matching Height of Cut.....	45
Side Discharging or Mulching the Grass.....	17	Replacing the Grass Deflector.....	46
Adjusting the Height-of-Cut.....	18	Cleaning.....	47
Adjusting the Anti-Scalp Rollers.....	18	Cleaning Under the Mower.....	47
Adjusting the Flow Baffle.....	19	Waste Disposal.....	47
Positioning the Flow Baffle.....	19	Storage.....	47
Using the Mid-Size Weight.....	21	Cleaning and Storage.....	47
Maintenance.....	22	Troubleshooting.....	49
Recommended Maintenance Schedule(s).....	22	Schematics.....	51
Lubrication.....	22		
How to Grease.....	22		
Lubricating the Bearings.....	23		
Greasing the PTO Drive Belt Idler.....	23		
Engine Maintenance.....	24		
Servicing the Air Cleaner.....	24		
Servicing the Engine Oil.....	24		
Servicing the Spark Plugs.....	26		
Fuel System Maintenance.....	27		
Draining the Fuel Tank.....	27		
Replacing the Fuel Filter.....	28		
Electrical System Maintenance.....	29		
Servicing the Fuses.....	29		
Drive System Maintenance.....	29		
Adjusting the Tracking.....	29		
Checking the Tire Pressure.....	29		
Replacing the Caster Wheel Fork Bushings.....	30		
Servicing the Caster Wheel and Bearings.....	30		
Adjusting the Electric Clutch.....	31		
Cooling System Maintenance.....	32		
Cleaning the Air Intake Screen.....	32		
Brake Maintenance.....	32		
Servicing the Brake.....	32		
Belt Maintenance.....	33		
Inspecting the Belts.....	33		
Replacing the Mower Belt.....	33		
Replacing the PTO Drive Belt.....	34		
Adjusting the PTO Drive Belt Idler Spring Anchor.....	34		
Replacing the Pump Drive Belt.....	35		
Controls System Maintenance.....	36		
Adjusting the Motion Control Handle Positions.....	36		
Hydraulic System Maintenance.....	38		
Servicing the Hydraulic System.....	38		

# Safety

**Improperly using or maintaining this mower can result in injury. To reduce the potential for injury, comply with these safety instructions.**

Toro designed and tested this mower for reasonably safe service; however, failure to comply with the following instructions may result in personal injury.

**To ensure maximum safety, best performance, and to gain knowledge of the product, it is essential that you and any other operator of the mower read and understand the contents of this manual before the engine is ever started. Pay particular attention to the safety alert symbol (Figure 2) which means Caution, Warning, or Danger—“personal safety instruction.” Read and understand the instruction because it has to do with safety. Failure to comply with the instruction may result in personal injury.**

## General Lawn Mower Safety

The following instructions have been adapted from the ISO standard 5395.

This cutting machine is capable of amputating hands and feet and throwing objects. Failure to observe the following safety instructions could result in serious injury or death.

### Training

- Read the instructions carefully. Be familiar with the controls and the proper use of the equipment.
- Never allow children or people unfamiliar with these instructions to use the mower. Local regulations can restrict the age of the operator.
- Keep in mind that the operator or user is responsible for accidents or hazards occurring to other people or their property.
- Understand explanations for all pictograms used on the mower or in the instructions.

### Gasoline

**WARNING**-Gasoline is highly flammable. Take the following precautions.

- Store fuel in containers specifically designed for this purpose.
- Refuel outdoors only and do not smoke while refueling.
- Add fuel before starting the engine. Never remove the cap of the fuel tank or add gasoline while the engine is running or when the engine is hot.

- If gasoline is spilled, do not attempt to start the engine but move the mower away from the area of spillage and avoid creating any source of ignition until gasoline vapors have dissipated.
- Replace all fuel tank and container caps securely.

### Preparation

- While mowing, always wear substantial footwear and long trousers. Do not operate the equipment when barefoot or wearing open sandals.
- Thoroughly inspect the area where the equipment is to be used and remove all stones, sticks, wires, bones and other foreign objects.
- Before using, always visually inspect to see that guards, and safety devices, such as deflectors and/or grass catchers, are in place and working correctly.
- Before using, always visually inspect to see that the blades, blade bolts and cutter assembly are not worn or damaged. Replace worn or damaged blades and bolts in sets to preserve balance.

### Starting

- Disengage all blade and drive clutches and shift into neutral before starting the engine.
- Do not tilt mower when starting the engine or switching on the motor, unless the mower has to be tilted for starting. In this case, do not tilt it more than absolutely necessary and lift only the part, which is away from the operator.
- Start the engine or switch on the motor carefully according to instructions and with feet well away from the blade(s) and not in front of the discharge chute.

### Operation

- Never mow while people, especially children, or pets are nearby.
- Mow only in daylight or in good artificial light.
- Avoid operating the lawn mower in wet grass, where feasible.
- Stay alert for holes in the terrain and other hidden hazards.
- Never direct discharge of material towards bystanders.
- Do not put hands or feet near or under rotating parts. Keep clear of the discharge opening at all times.
- Never pick up or carry a lawn mower while the engine is running.

- Use extreme caution when reversing or pulling a pedestrian controlled lawn mower towards you.
- Walk, never run.
- Slopes:
  - Do not mow excessively steep slopes.
  - Exercise extreme caution when on slopes.
  - Mow across the face of slopes, never up and down and exercise extreme caution when changing direction on slopes.
  - Always be sure of your footing on slopes.
- Use low throttle settings when engaging the traction-clutch, especially in high gears. Reduce speed on slopes and in sharp turns to prevent overturning or loss of control.
- Stop the blade if the lawn mower has to be tilted for transportation when crossing surfaces other than grass and when transporting the lawn mower to and from the area to be mowed.
- Do not operate the engine in a confined space where dangerous carbon monoxide fumes can collect.
- Stop the engine
  - whenever you leave the lawn mower.
  - before refueling.
  - before removing the grass catcher.
  - before making height adjustment unless adjustment can be made from the operator's position.
- Stop the engine and disconnect the spark-plug wire or turn off and remove the key.
  - before clearing blockages or unclogging chute.
  - before checking, cleaning or working on the lawn mower.
  - after striking a foreign object, inspect the lawn mower for damage and make repairs before restarting and operating the lawn mower.
  - if lawn mower starts to vibrate abnormally (check immediately).
- Use care when using sulkies, and
  - use only approved drawbar hitch points.
  - limit loads to those you can safely control.
  - do not turn sharply: use care when reversing.
  - do not carry passengers.
- Watch out for traffic when crossing or near roadways.
- Before leaving the operator's position
  - disengage the power take-off and lower the attachments.

- change into neutral and set the parking brake.
- stop the engine and remove the key.

## Maintenance and Storage

- Keep all nuts, bolts and screws tight to be sure the equipment is in safe working condition.
- Do not use pressure cleaning equipment on machine.
- Never store the equipment with gasoline in the tank and inside a building where fumes can reach an open flame or spark.
- Allow the engine to cool before storing in any enclosure.
- To reduce the fire hazard, keep the engine, silencer, battery compartment and gasoline storage are free of grass, leaves, or excessive grease.
- Check grass catcher components and the discharge guard frequently and replace with manufacturer's recommended parts, when necessary.
- Replace worn or damaged parts for safety.
- Replace faulty silencers.
- If the fuel tank has to be drained, do this out-doors.
- Do not change the engine governor settings or overspeed the engine. Operating an engine at excessive speed can increase the hazard of personal injury.
- On multibladed lawn mowers, take care as rotating one blade may cause others to rotate.
- Be careful during adjustment of the lawn mower to prevent entrapment of the fingers between moving blades and fixed parts of the lawn mower.
- **To ensure the best performance and safety, purchase only genuine Toro replacement parts and accessories. Do not use *will fit* parts and accessories; they may cause a safety hazard.**

## Sound Pressure

This unit has an equivalent continuous A-weighted sound pressure level at the operator ear of 87 dBA, based on measurements of identical machines per EN 11094 and EN 836.

## Sound Power

This unit has an equivalent continuous A-weighted sound power level of 100 dBA, based on measurements of identical machines per EN 11094.

## **Vibration, Hand/arm**

This unit does not exceed a hand/arm vibration level of  $2.0 \text{ m/s}^2$ , based on measurements of identical machines per EN 1033.

# Slope Chart

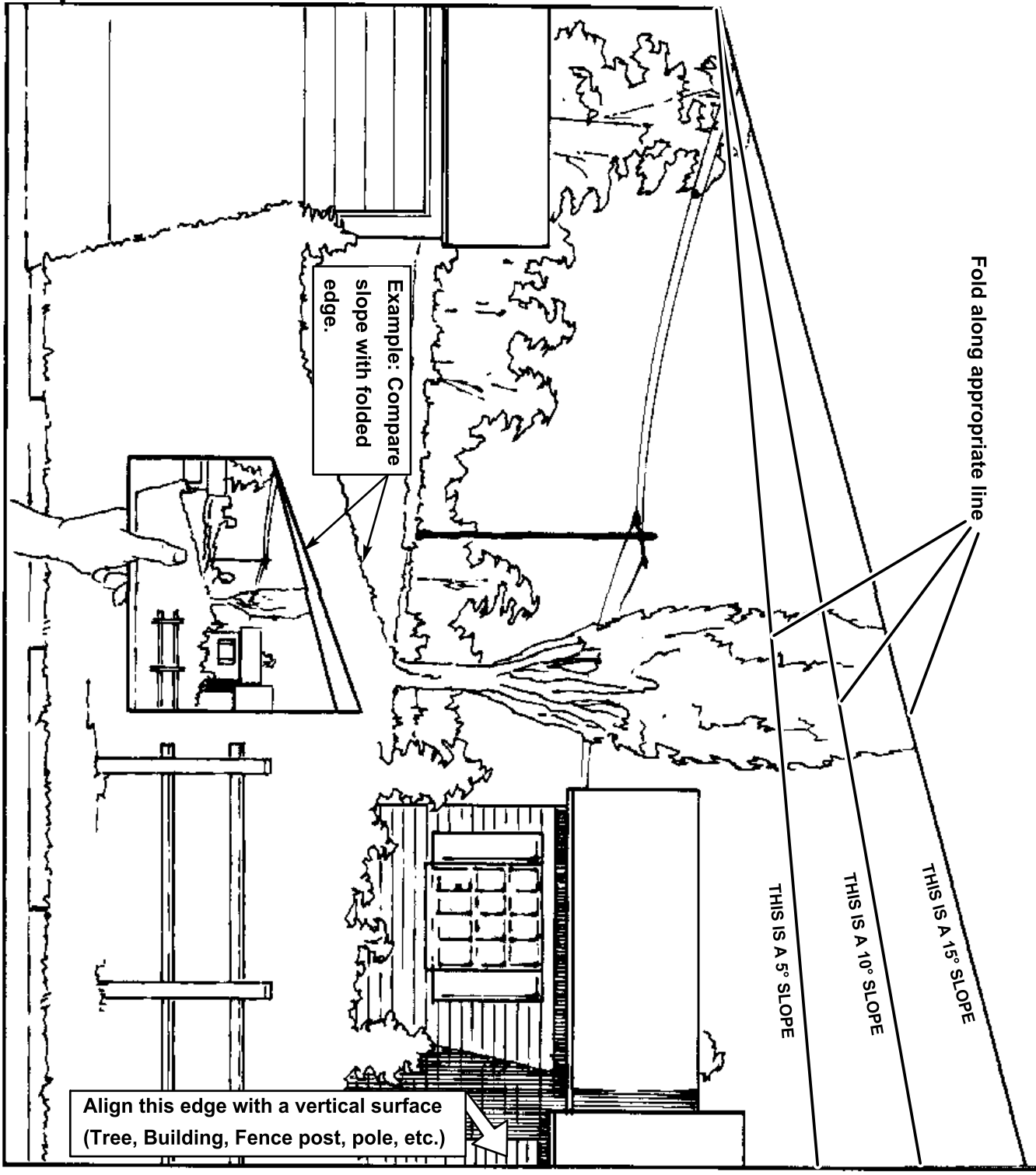

# Safety and Instructional Decals



Safety decals and instructions are easily visible to the operator and are located near any area of potential danger. Replace any decal that is damaged or lost.

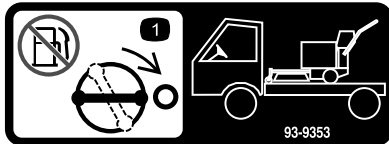

93-9353

1. Shut off fuel valve before transporting, rotate knob clockwise until it stops.

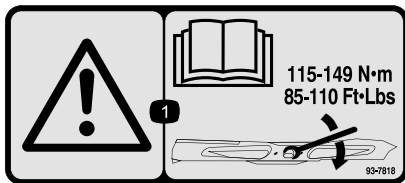

93-7818

1. Warning—read the *Operator's Manual* for instructions on torquing the blade bolt/nut to 115-149 N•m (85-110 ft•lb).



93-7828

1. Thrown object hazard, mower—keep the deflector in place.
2. Cutting/dismemberment of hand or foot—stay away from moving parts.

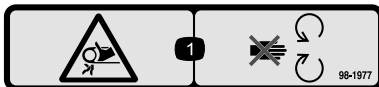

98-1977

1. Entanglement hazard, belt—stay away from moving parts.

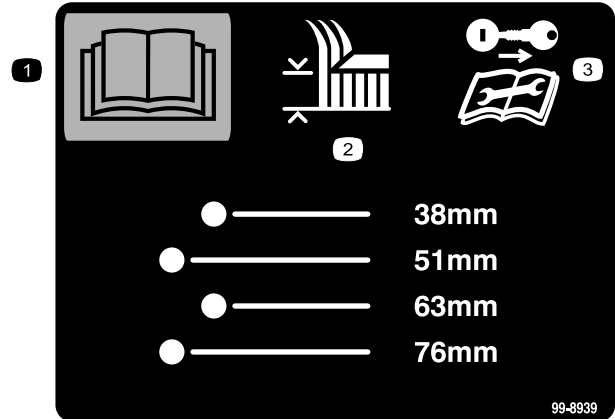

99-8939

1. Read the *Operator's Manual*.
2. Height of cut
3. Remove the ignition key and read the instructions before servicing or performing maintenance.

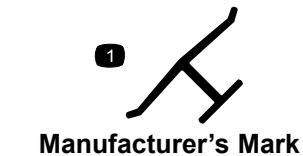

Manufacturer's Mark

1. Indicates the blade is identified as a part from the original machine manufacturer.

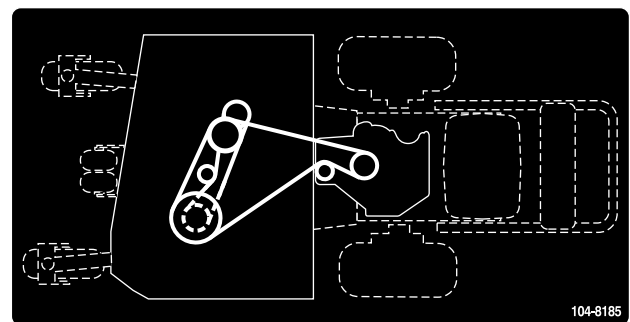

104-8185

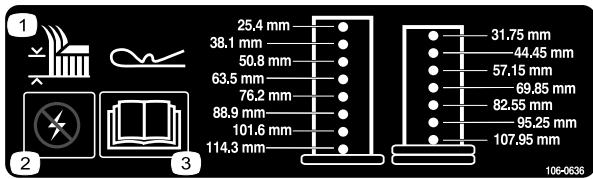

106-0636

1. Height-of-cut
2. Warning—power
3. Read the *Operator's Manual* for more information.

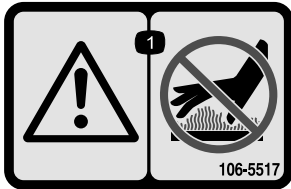

106-5517

1. Warning—do not touch the hot surface.



107-2131

1. Hydraulic oil level
2. Warning—do not touch the hot surface.

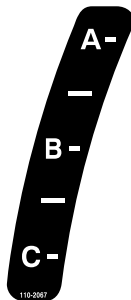

110-2067

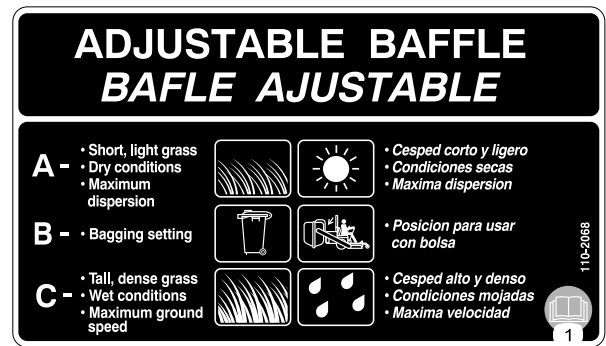

110-2068

1. Read the *Operator's Manual*.

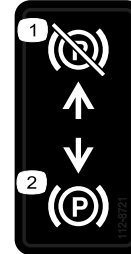

112-8721

1. Parking brake—off
2. Parking brake—on

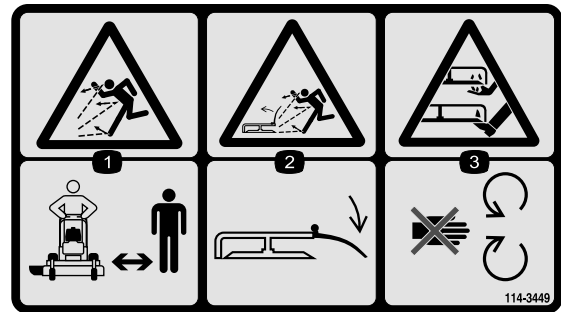

114-3449

1. Thrown object hazard—keep bystanders a safe distance from the machine.
2. Thrown object hazard, mower—keep the deflector in place.
3. Cutting/dismemberment of hand or foot—stay away from moving parts.

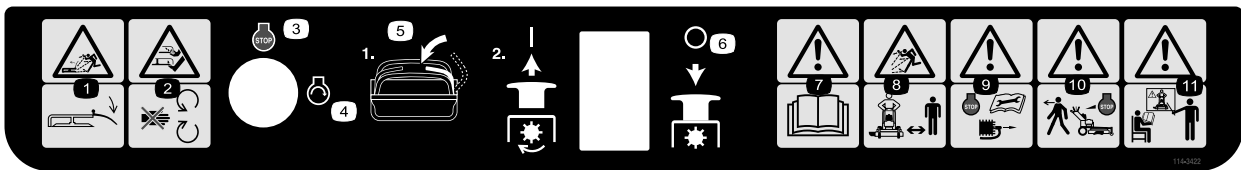

114-3422

- |   |  |   |   |
|---|--|---|---|
| 1. Thrown object hazard—keep deflector in place.                              | 4. Engine—start  | 7. Warning—read the <i>Operator's Manual</i> .  | 10. Warning—stop the engine before leaving the machine.         |
| 2. Cutting, dismemberment hazard of hand or foot—stay away from moving parts. | 5. Move the motion control lever to the neutral position, then pull out on PTO (Power Take Off) switch to engage the blades. | 8. Thrown object hazard—keep bystanders a safe distance from the machine.                                   | 11. Warning—do not operate this machine unless you are trained. |
| 3. Engine—stop  | 6. Push in on the PTO (Power Take Off) to disengage the blades.  | 9. Warning—stop the engine and remove the spark plug wire before performing any maintenance on the machine. |   |

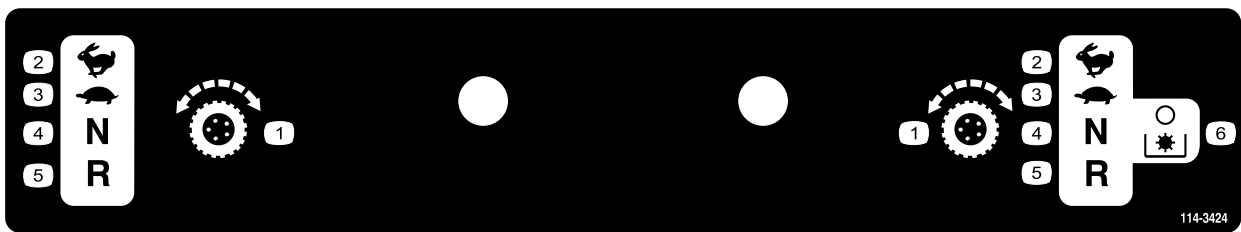

114-3424

- |                     |            |                                       |
|---------------------|------------|---------------------------------------|
| 1. Traction control | 3. Slow    | 5. Reverse                            |
| 2. Fast             | 4. Neutral | 6. Disengage the PTO (Power Take Off) |



114-3442

- |                                |           |          |
|--------------------------------|-----------|----------|
| 1. Fast                        | 3. Engine | 5. Choke |
| 2. Continuous variable setting | 4. Slow   |          |

# Product Overview

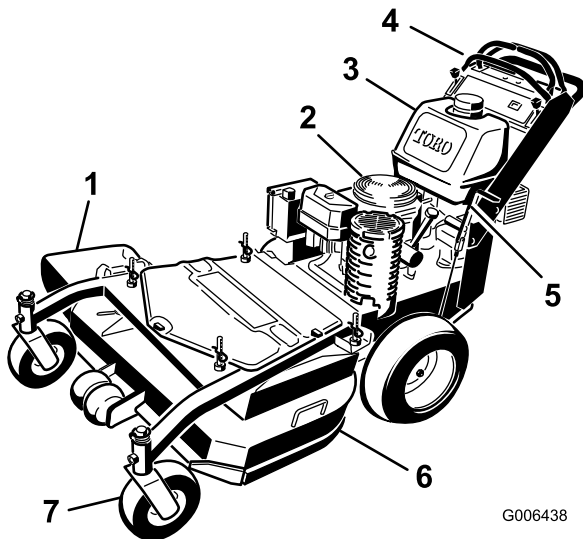

Figure 3

- |                         |                       |
|-------------------------|-----------------------|
| 1. Side discharge chute | 5. Parking brake      |
| 2. Engine               | 6. Mower deck         |
| 3. Gas tank             | 7. Front caster wheel |
| 4. Controls             |                       |

## Controls

Become familiar with all the controls (Figure 4) before you start the engine and operate the machine.

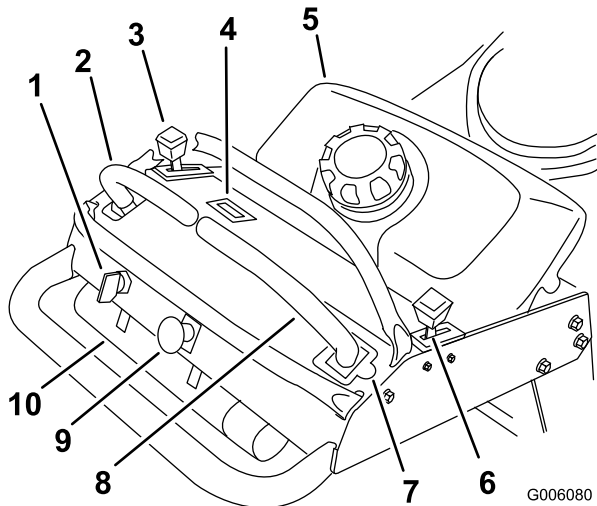

Figure 4

- |                              |   |
|------------------------------|---|
| 1. Ignition switch           | 6. Choke  |
| 2. Left motion control lever | 7. Neutral lock position for right motion control lever |
| 3. Throttle control          | 8. Right motion control lever                           |
| 4. Hour meter                | 9. blade control switch (PTO)                           |
| 5. Fuel tank                 | 10. Operator manual tube                                |

## Throttle Control

The throttle control has two positions: **Fast** and **Slow**.

## Choke

Use the choke to start a cold engine.

## Blade Control Switch (PTO)

The blade control switch (PTO) is used to engage the electric clutch to drive the mower blades with the right side motion control lever in the center, un-locked position. Pull the switch up to engage the blades and release. To disengage the blades, push the blade control switch (PTO) down or move or release the right side motion control lever into the neutral lock position.

## Ignition Switch

This switch is used to start the mower engine and has three positions: **Start**, **Run** and **Off**.

## Motion Control Levers

The motion control levers are used to drive the machine forward, reverse, and turn either direction.

## Neutral Lock Position

The neutral lock position is used with the safety interlock system to engage and disengage the mower blades and to determine neutral position.

## Fuel Shut-off Valve

Close the fuel shut-off valve (under the fuel tank ) when transporting or storing the mower.

## Hour Meter

Shows the total hours the machine has been operated. This operates only when the mower blades are operating.

The hour meter will flash 3 hours before and after a service interval. The service intervals are set for the first 8 hours, every 100 hours there after, and every 400 hours.

**Note:** Make sure maintenance is done at all recommended intervals shown in the Recommended Maintenance Schedule.

## Attachments/Accessories

A selection of Toro approved attachments and accessories are available for use with the machine to enhance and expand its capabilities. Contact your Authorized Service Dealer or Distributor or go to

## Specifications

**Note:** Specifications and design are subject to change without notice.

Width with deflector down	51–1/8 inches (130 cm)
Length	78–1/2 inches (199 cm)
Height	46 inches (117 cm)
Weight	667 lb (303 kg)

# Operation

## Adding Fuel

Use **Unleaded** Regular Gasoline suitable for automotive use (85 pump octane minimum). Leaded regular gasoline may be used if unleaded regular is not available.

**Important:** Never use methanol, gasoline containing methanol, or gasohol containing more than 10% ethanol because the fuel system could be damaged. Do not mix oil with gasoline.



In certain conditions, gasoline is extremely flammable and highly explosive. A fire or explosion from gasoline can burn you and others and can damage property.

- Fill the fuel tank outdoors, in an open area, when the engine is cold. Wipe up any gasoline that spills.
- Never fill the fuel tank inside an enclosed trailer.
- Do not fill the fuel tank completely full. Add gasoline to the fuel tank until the level is 1/4 to 1/2 inch (6 to 13 mm) below the bottom of the filler neck. This empty space in the tank allows gasoline to expand.
- Never smoke when handling gasoline, and stay away from an open flame or where gasoline fumes may be ignited by a spark.
- Store gasoline in an approved container and keep it out of the reach of children. Never buy more than a 30-day supply of gasoline.
- Do not operate without entire exhaust system in place and in proper working condition.



In certain conditions during fueling, static electricity can be released causing a spark which can ignite the gasoline vapors. A fire or explosion from gasoline can burn you and others and can damage property.

- Always place gasoline containers on the ground away from your vehicle before filling.
- Do not fill gasoline containers inside a vehicle or on a truck or trailer bed because interior carpets or plastic truck bed liners may insulate the container and slow the loss of any static charge.
- When practical, remove gas-powered equipment from the truck or trailer and refuel the equipment with its wheels on the ground.
- If this is not possible, then refuel such equipment on a truck or trailer from a portable container, rather than from a gasoline dispenser nozzle.
- If a gasoline dispenser nozzle must be used, keep the nozzle in contact with the rim of the fuel tank or container opening at all times until fueling is complete.



Gasoline is harmful or fatal if swallowed. Long-term exposure to vapors can cause serious injury and illness.

- Avoid prolonged breathing of vapors.
- Keep face away from nozzle and gas tank or conditioner opening.
- Keep gas away from eyes and skin.

## Using Stabilizer/Conditioner

Use a fuel stabilizer/conditioner in the machine to provide the following benefits:

- Keeps gasoline fresh during storage of 90 days or less. For longer storage it is recommended that the fuel tank be drained.
- Cleans the engine while it runs
- Eliminates gum-like varnish buildup in the fuel system, which causes hard starting

**Important:** Do not use fuel additives containing methanol or ethanol.

Add the correct amount of gas stabilizer/conditioner to the gas.

**Note:** A fuel stabilizer/conditioner is most effective when mixed with fresh gasoline. To minimize the chance of varnish deposits in the fuel system, use fuel stabilizer at all times.

## Filling the Fuel Tank

1. Shut the engine off and set the parking brake.
2. Clean around fuel tank cap and remove the cap. Add unleaded regular gasoline to fuel tank, until the level is 1/4 to 1/2 inch (6 to 13 mm) below the bottom of the filler neck. This space in the tank allows gasoline to expand. Do not fill the fuel tank completely full.
3. Install fuel tank cap securely. Wipe up any gasoline that may have spilled.

## Checking the Engine Oil Level

Before you start the engine and use the machine, check the oil level in the engine crankcase; refer to Checking Oil Level in Engine Maintenance.

**Note:** Determine the left and right sides of the machine from the normal operating position.

## Think Safety First

Carefully read all the safety instructions and decals in the safety section. Knowing this information could help you or any bystanders avoid injury.

The use of protective equipment for eyes, hearing, feet and head is recommended.



This machine produces sound levels in excess of 85 dBA at the operator's ear and can cause hearing loss through extended periods of exposure.

**Wear hearing protection when operating this machine.**

## Operating the Parking Brake

Always set the parking brake when you stop the machine or leave it unattended. Before each use, check the parking brake for proper operation.

If the parking brake does not hold securely, adjust it. Refer to Servicing the Parking Brake.



Children or bystanders may be injured if they move or attempt to operate the machine while it is unattended.

Always remove the ignition key and set the parking brake when leaving the machine unattended, even if just for a few minutes.

## Setting the Parking Brake

Pull the parking brake lever rearward (Figure 5).

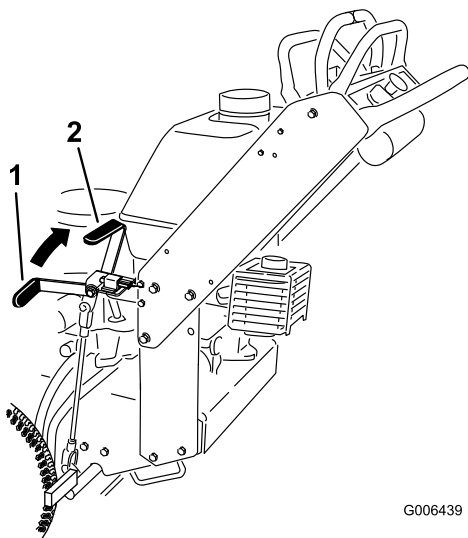

Figure 5

1. Parking brake lever (in the released position)
2. Parking brake lever (in the engaged position)

## Releasing the Parking Brake

Push the parking brake lever forward.

## Starting and Stopping the Engine

### Starting the Engine

1. Connect the wires to the spark plugs.
2. Open the fuel valve.
3. Set the parking brake.
4. Move the throttle control to fast and move the choke lever to the on position before starting a cold engine (Figure 6).

**Note:** A warm or hot engine may not require choking. To start a warm engine, move throttle control midway between the **fast** and **slow** positions.

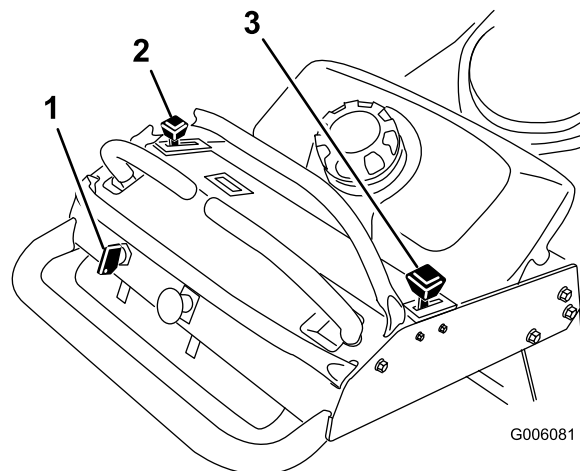

Figure 6

1. Ignition switch
2. Throttle lever
3. Choke

5. Turn the ignition key to the start position to energize the starter. When the engine starts, release the key.

**Note:** Do not engage the starter for more than 5 seconds at a time. If the engine fails to start, allow for a 15 second cool-down period between attempts. Failure to follow these instructions can burn out the starter motor.

6. When engine starts, move the throttle control between the fast and slow position and move the choke lever to the off position. Allow the engine to warm up and then move the throttle control to the fast position.

## Stopping the Engine

1. Move the motion control levers to neutral and move the right side motion control lever into the neutral lock position.
2. Move the throttle lever to slow (Figure 6).
3. If the engine has been working hard or is hot, let the engine idle for 30 to 60 seconds before turning the engine off.
4. To stop the engine, turn the ignition key to off.

**Important:** Make sure fuel shut off valve is closed before transporting or storing the machine, as fuel leakage may occur. Before storing the machine, pull wire off spark plug(s) to prevent possibility of accidental starting.

## Operating the Mower Blade Control (PTO)

The blade control switch (PTO) is used in conjunction with the right side motion control lever to engage and disengage the mower blades.

### Engaging the Mower Blades (PTO)

1. To engage the mower blades, move the right side motion control lever to the center, un-locked position (Figure 7).
2. Pull the blade control switch (PTO) up and release it while holding down the right side motion control lever in the center, un-locked position.

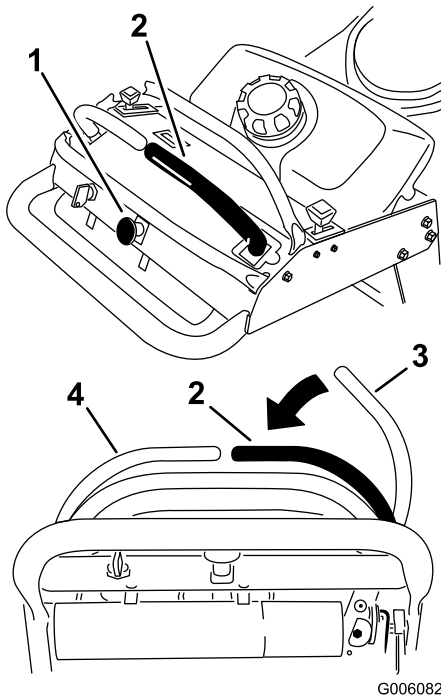

Figure 7

- |  |  |
|--|--|
| 1. Blade control switch (PTO)  | 3. Right motion control lever in neutral lock position |
| 2. Right side motion control lever pushed down into the center, un-locked position | 4. Left motion control lever                           |

### Disengaging the Mower Blades (PTO)

The following are two options for disengaging the mower blades.

- Push the blade control switch (PTO) down to the off position.
- Move the motion control levers to neutral and move the right side motion control lever into the neutral lock position.

## The Safety Interlock System



If safety interlock switches are disconnected or damaged the machine could operate unexpectedly causing personal injury.

- Do not tamper with the interlock switches.
- Check the operation of the interlock switches daily and replace any damaged switches before operating the machine.

### Understanding the Safety Interlock System

The safety interlock system is designed to prevent the mower blades from rotating unless:

- The right side motion control lever is moved to the center, un-locked position.
- The blade control switch (PTO) is pulled on.

The safety interlock system is designed to stop the mower blades if you move or release the right side motion control lever into the neutral lock position.

### Testing the Safety Interlock System

**Service Interval:** Before each use or daily

**Note:** If the safety system does not operate as described below, have an Authorized Service Dealer repair the safety system immediately.

1. Start the engine; refer to Starting and Stopping the Engine in Operation , page 12.
2. Set the parking brake.
3. Move the right side motion control lever to the center, un-locked position. **The blades should not rotate.**
4. Move the motion control levers forward. **The engine should kill.**
5. Start the engine and release the parking brake.
6. Move the right side motion control lever to the center, un-locked position.
7. Continue holding the right side motion control lever in the center, un-locked position and pull up on the blade control switch (PTO) and release. The clutch should engage and the mower blades begin rotating.
8. Move or release the right side motion control lever into the neutral lock position. **The blades should stop rotating.**

9. Move the right side motion control lever to the center, un-locked position.
10. Continue holding the right side motion control lever in the center, un-locked position and pull up on the blade control switch (PTO) and release. The clutch should engage and the mower blades begin rotating.
11. Push the blade control switch (PTO) down to the off position. **The blades should stop rotating.**
12. With the engine running, pull up the blade control switch (PTO) and release without holding right side motion control lever to the center, un-locked position. **The blades should not rotate.**

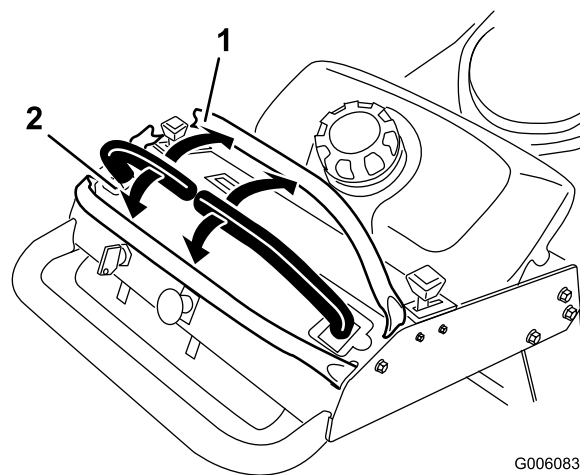

**Figure 8**

1. Forward
2. Backward

## Driving Forward or Backward

The throttle control regulates the engine speed as measured in rpm (revolutions per minute). Place the throttle control in the fast position for best performance. Always operate in the full throttle position when mowing.



**Machine can spin very rapidly. Operator may lose control of machine and cause personal injury or damage to machine.**

- Use caution when making turns.
- Slow the machine down before making sharp turns.

### Driving Forward

1. Release the parking brake; refer to Releasing the Parking Brake in Operation , page 12.
2. Move the right side motion control lever to the center, un-locked position.
3. To go forward, slowly push the motion control levers forward (Figure 8).

**Note:** The engine will kill if the traction control levers are moved with the parking brake engaged.

To go straight, apply equal pressure to both motion control levers (Figure 8).

To turn, move the motion control lever toward neutral in the direction you want to turn (Figure 8).

The farther you move the traction control levers in either direction, the faster the machine will move in that direction.

To stop, pull the motion control levers back to the neutral position.

### Driving Backward

1. Move the right side motion control lever to the center, un-locked position.
2. To go backward, slowly pull the motion control levers rearward (Figure 8).

To go straight, apply equal pressure to both motion control levers (Figure 8).

To turn, release pressure on the motion control lever toward the direction you want to turn (Figure 8).

To stop, push the motion control levers to the neutral position.

### Stopping the Machine

To stop the machine, move the motion control levers to neutral, move the right side motion control lever into the neutral lock position, disengage the power take off (PTO), and turn the ignition key to off.

Set the parking brake when you leave the machine; refer to Setting the Parking Brake in Operation , page 12. Remember to remove the key from the ignition switch.



**Children or bystanders may be injured if they move or attempt to operate the tractor while it is unattended.**

**Always remove the ignition key and set the parking brake when leaving the machine unattended, even if just for a few minutes.**

## Pushing the Machine by Hand

The by-pass valves allow the machine to be pushed by hand without the engine running.

**Important:** Always push the machine by hand. Never tow the machine because hydraulic damage may occur.

### To Push the Machine

1. Disengage the PTO, move the motion control levers to the neutral locked position and set the parking brake.
2. Open the by-pass valve on both pumps by turning them counter clockwise 1 to 2 turns. This allows hydraulic fluid to by-pass the pumps and the wheels to turn (Figure 9).

**Note:** Rotate the by-pass valves a maximum of 2 turns so the valve does not come out of the body causing fluid to run out.

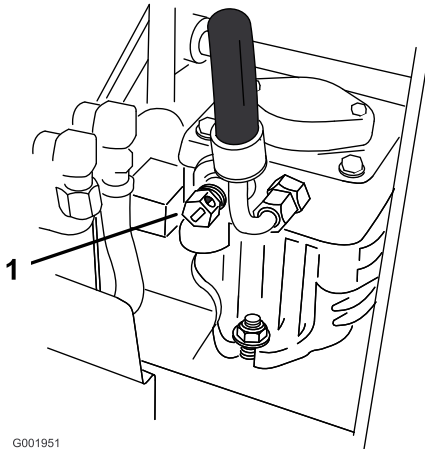

Figure 9

1. Pump by-pass valve

3. Release the parking brake.
4. Push the machine to the desired location.
5. Set the parking brake.
6. Close the by-pass valves, but do not overtighten them.

**Important:** Do not start or operate the machine with the by-pass valves open. Damage to system may occur.

## Transporting Machines

Use a heavy-duty trailer or truck to transport the machine. Ensure that the trailer or truck has all

necessary brakes, lighting, and marking as required by law. Please carefully read all the safety instructions. Knowing this information could help you, your family, pets or bystanders avoid injury.

To transport the machine:

1. If using a trailer, connect it to the towing vehicle and connect the safety chains.
2. If applicable, connect the trailer brakes.
3. Load the machine onto the trailer or truck.
4. Stop the engine, remove the key, set the brake, and close the fuel valve.
5. Use the metal tie down loops on the machine to securely fasten the machine to the trailer or truck with straps, chains, cable, or ropes (Figure 10).
6. Fasten the front of the machine to the trailer or truck with straps, chains, cable, or ropes.

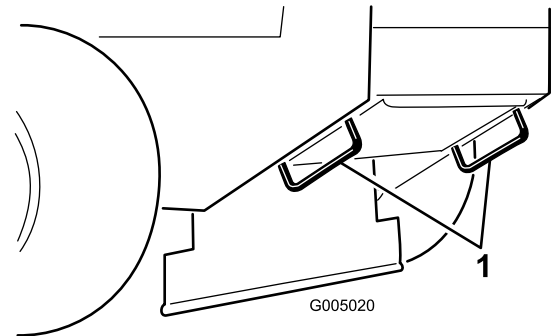

Figure 10

1. Traction unit tie down loop

## Side Discharging or Mulching the Grass

This mower has a hinged grass deflector that disperses clippings to the side and down toward the turf.



Without the grass deflector, discharge cover, or complete grass catcher assembly mounted in place, you and others are exposed to blade contact and thrown debris. Contact with rotating mower blade(s) and thrown debris will cause injury or death.

- Never remove the grass deflector from the mower because the grass deflector routes material down toward the turf. If the grass deflector is ever damaged, replace it immediately.
- Never put your hands or feet under the mower.
- Never try to clear discharge area or mower blades unless you release the bail and the power take off (PTO) is off. Rotate the ignition key to Off. Also remove the key and pull the wire(s) off the spark plug(s).

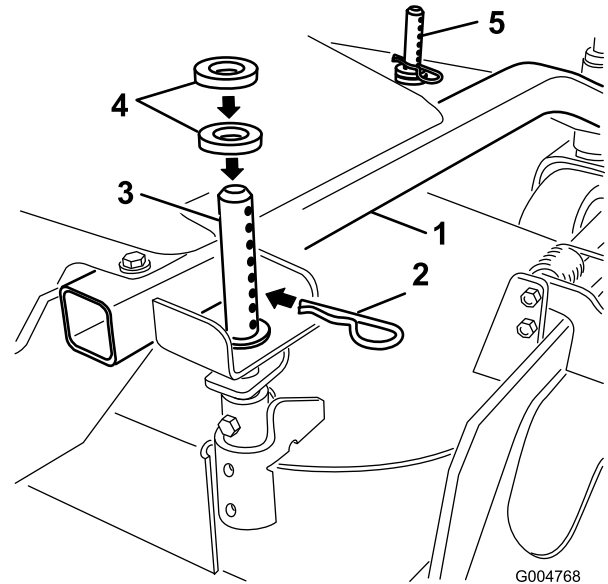

Figure 11

1. Carrier Frame
2. Hairpin Cotter
3. Back height-of-cut post
4. Spacers
5. Front height-of-cut post

## Adjusting the Height-of-Cut

The height-of-cut can be adjusted from 1 to 4-1/2 inch (25 to 114 mm) in 1/4 inch (6 mm) increments. Adjustment is done by relocating four hairpin cotter pins in different hole location and by adding or removing spacers.

**Note:** All height-of-cut pins need at least one spacer or damage can occur to bushing if none are used.

**Note:** All height-of-cut pins can use two spacers maximum.

1. Select hole in height-of-cut post and number of spacers corresponding to the height-of-cut desired (Figure 11).
2. Using the lift handle, raise side of deck and remove hairpin cotter (Figure 11).
3. Add or remove spacers if needed and then align holes and insert hairpin cotter (Figure 11).

**Note:** Spare height-of-cut spacers may be stored on posts and retained by a hairpin cotter.

**Important:** All four hairpin cotter pins must be in the same hole location and with the correct number of spacers for a level cut.

## Adjusting the Anti-Scalp Rollers

The anti-scalp rollers need to be adjusted in the proper hole location for each height-of-cut position. There needs to be 3/8 inch (10 mm) minimum clearance above the ground.

**Note:** If the anti-scalp rollers are adjusted too low it can cause excess wear of the rollers.

1. After adjusting height-of-cut, check the anti-scalp rollers so that there is a minimum of 3/8 inch (10 mm) clearance above the ground (Figure 12).
2. If adjustment is needed, remove the bolt, washers and nut (Figure 12).
3. Select a hole position so the anti-scalp rollers are a minimum of 3/8 inch (10 mm) off the ground (Figure 12).
4. Install the bolt and nut (Figure 12).

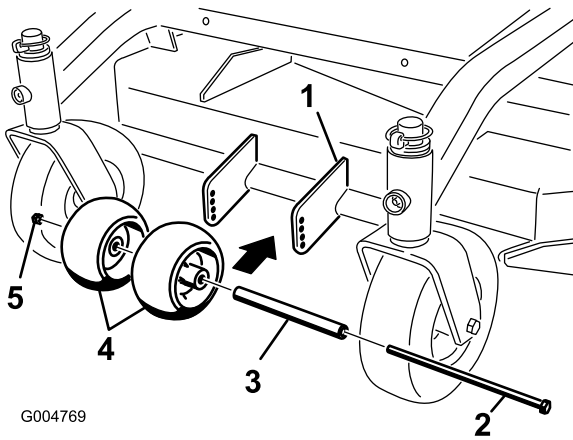

Figure 12

- |               |                       |
|---------------|-----------------------|
| 1. Mower deck | 4. Anti-Scalp Rollers |
| 2. Bolt       | 5. Nut                |
| 3. Spacer     |                       |

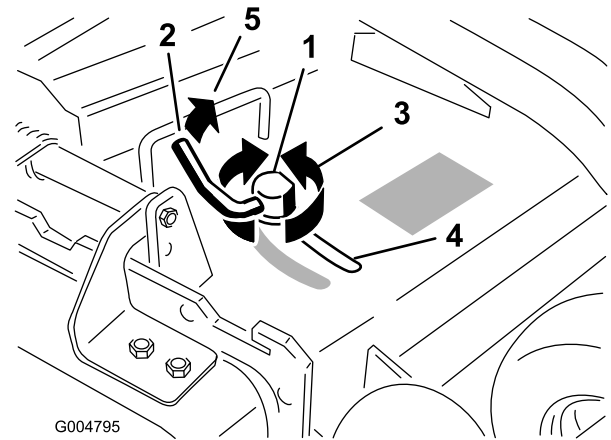

Figure 13

- |             |  |
|-------------|--|
| 1. Cam lock | 3. Rotate cam to increase or decrease locking pressure |
| 2. Lever    | 4. Slot  |

- In certain mowing conditions and terrain, a mismatch of cutting height may be seen. Adjusting the outside anti-scalp rollers to the minimum setting of 3/8 inch (10 mm) will help prevent the mower deck cutting too low on the outside and minimize the mismatch.

## Adjusting the Flow Baffle

The mower discharge flow can be adjusted for different types of mowing conditions. Position the cam lock and baffle to give the best quality of cut.

- Disengage the PTO, move the motion control levers to the neutral locked position and set the parking brake.
- Stop the engine, remove the key, and wait for all moving parts to stop before leaving the operating position.
- To adjust the cam lock, swing the lever up to loosen the cam lock (Figure 13).
- Adjust the baffle and cam lock in the slot to the desired discharge flow.
- Swing the lever back over to tighten the baffle and cam lock (Figure 13).
- If the cam does not lock the baffle into place or it is too tight, loosen the lever and then rotate the cam lock. Adjust the cam lock until the desired locking pressure is achieved.

## Positioning the Flow Baffle

The following figures are only recommendations for use. Adjustments will vary by grass type, moisture content, and height of grass.

**Note:** If the engine power draws down and the mower ground speed is the same, open up the baffle.

### Position A

This is the full rear position (see Figure 14). The suggested use for this position is as follows.

- Use for short, light grass mowing conditions.
- Use in dry conditions.
- For smaller grass clippings.
- Propels grass clippings farther away from the mower.

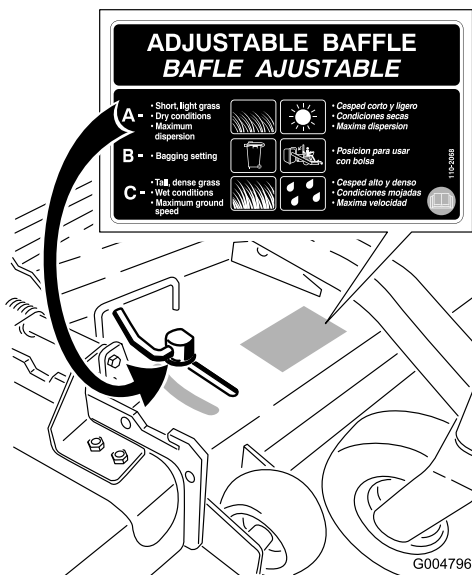

Figure 14

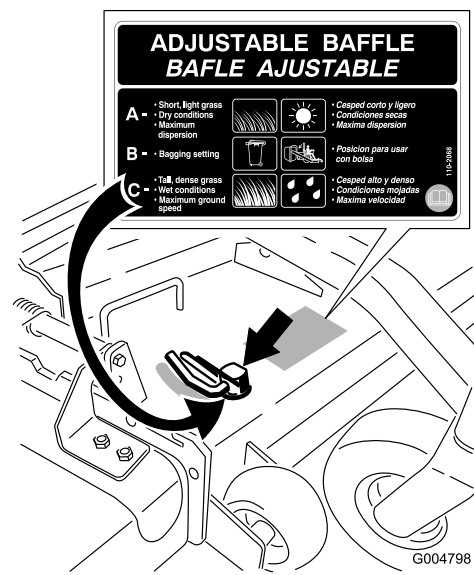

Figure 16

## Position B

Use this position when bagging (Figure 15).



Figure 15

## Position C

This is the full open position. The suggested use for this position is as follows (Figure 16).

- Use in tall, dense grass mowing conditions.
- Use in wet conditions.
- Lowers the engine power consumption.
- Allows increased ground speed in heavy conditions.
- This position is similar to the benefits of the Toro SFS mower.

# Using the Mid-Size Weight

Weights are installed on certain mowers to improve balance and improve performance. The weights can be moved or removed to create optimized performance under different mowing conditions and for operator preference (Figure 17 or Figure 18).

The following table indicates the position of the weight as installed at the factory.

Mower Deck Size	Number of weights install	Position of the weight
91cm	1	Front

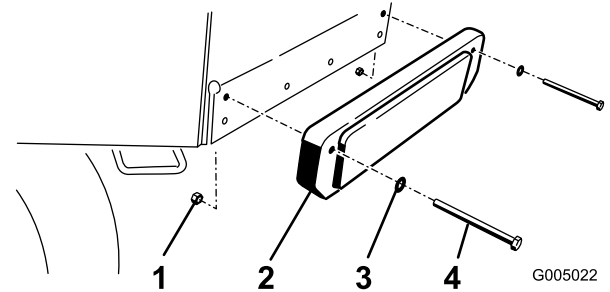

**Figure 18**

Installing the rear weight.

- 1. Nut
- 2. Weight
- 3. Washer
- 4. Bolt



**The front end of the machine can rapidly rise up when the mower is removed. This could cause serious injury to you or bystanders.**

**Support the rear of the machine when removing the mower from the carrier frame.**

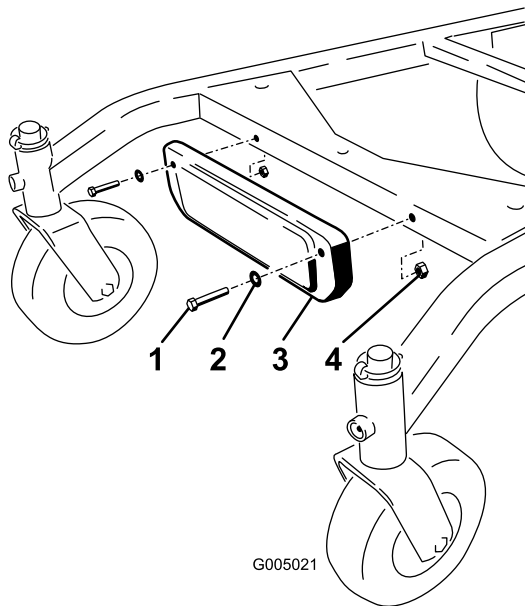

**Figure 17**

Installing the front weight.

- 1. Bolt
- 2. Washer
- 3. Weight
- 4. Nut

# Maintenance

**Note:** Determine the left and right sides of the machine from the normal operating position.

## Recommended Maintenance Schedule(s)

Maintenance Service Interval	Maintenance Procedure
After the first 8 hours	<ul style="list-style-type: none"> <li>• Change the engine oil.</li> <li>• Check the hydraulic fluid.</li> <li>• Change the hydraulic filter.</li> </ul>
Before each use or daily	<ul style="list-style-type: none"> <li>• Check the safety interlock system.</li> <li>• Grease the front caster pivot bearing.</li> <li>• Check the engine oil.</li> <li>• Clean the air intake screen.</li> <li>• Check the brakes.</li> <li>• Inspect the blades.</li> <li>• Clean the mower deck.</li> </ul>
Every 25 hours	<ul style="list-style-type: none"> <li>• Clean foam air cleaner element (more often in dirty or dusty conditions).</li> <li>• Check the hydraulic fluid.</li> </ul>
Every 50 hours	<ul style="list-style-type: none"> <li>• Grease the PTO belt idler.</li> <li>• Check the paper air filter (more often in dirty or dusty conditions).</li> <li>• Check the tire pressure. or monthly, whichever occurs first.</li> <li>• Inspect the belts for cracks and wear.</li> </ul>
Every 100 hours	<ul style="list-style-type: none"> <li>• Change the engine oil (more often in dirty or dusty conditions).</li> <li>• Check the spark plugs.</li> <li>• Adjust the electric clutch.</li> <li>• Check the hydraulic lines.</li> </ul>
Every 200 hours	<ul style="list-style-type: none"> <li>• Replace the paper air cleaner element (more often in dirty or dusty conditions).</li> <li>• Change the engine oil filter.</li> <li>• Replace the fuel filter. or yearly, whichever occurs first.</li> <li>• Change the hydraulic filter.</li> </ul>
Every 400 hours	<ul style="list-style-type: none"> <li>• Grease the front wheel bearings (more often in dirty or dusty conditions).</li> </ul>
Before storage	<ul style="list-style-type: none"> <li>• Paint chipped surfaces.</li> <li>• Perform all maintenance procedures listed above before storage.</li> </ul>

**Important:** Refer to your *Engine Operator's Manual* for additional maintenance procedures.



If you leave the key in the ignition switch, someone could accidentally start the engine and seriously injure you or other bystanders.

Remove the key from the ignition and disconnect the spark plug wires from the spark plugs before you do any maintenance. Set the wires aside so that they do not accidentally contact the spark plugs.

## Lubrication

Grease with No. 2 general purpose lithium base or molybdenum base grease.

## How to Grease

1. Disengage the PTO and set the parking brake.
2. Stop the engine, remove the key, and wait for all moving parts to stop before leaving the operating position.

3. Clean the grease fittings with a rag. Make sure to scrape any paint off the front of the fitting(s).
4. Connect a grease gun to the fitting. Pump grease into the fittings until grease begins to ooze out of the bearings.
5. Wipe up any excess grease.

## Lubricating the Bearings

**Service Interval:** Before each use or daily—Grease the front caster pivot bearing.

Every 400 hours—Grease the front wheel bearings (more often in dirty or dusty conditions).

Lubricate the front caster wheel bearings and front pivots (Figure 19).

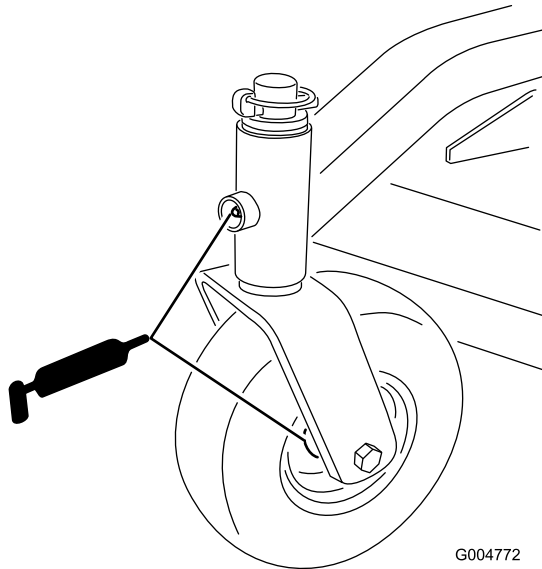

**Figure 19**

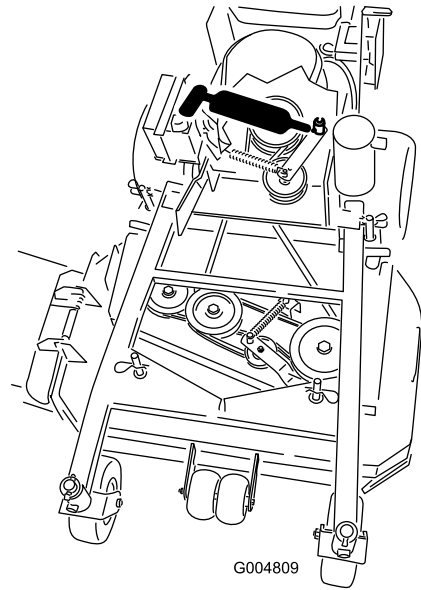

**Figure 20**

## Greasing the PTO Drive Belt Idler

**Service Interval:** Every 50 hours—Grease the PTO belt idler.

Grease the idler pulley pivot (Figure 20).

# Engine Maintenance

## Servicing the Air Cleaner

### Removing the Foam and Paper Elements

1. Disengage the PTO and set the parking brake.
2. Stop the engine, remove the key, and wait for all moving parts to stop before leaving the operating position.
3. Clean around the air cleaner to prevent dirt from getting into the engine and causing damage (Figure 21).
4. Unscrew the cover knob and remove the air cleaner cover (Figure 21).
5. Remove the 2 wing nuts and remove the air cleaner assembly (Figure 21).
6. Carefully pull the foam element off the paper element (Figure 21).

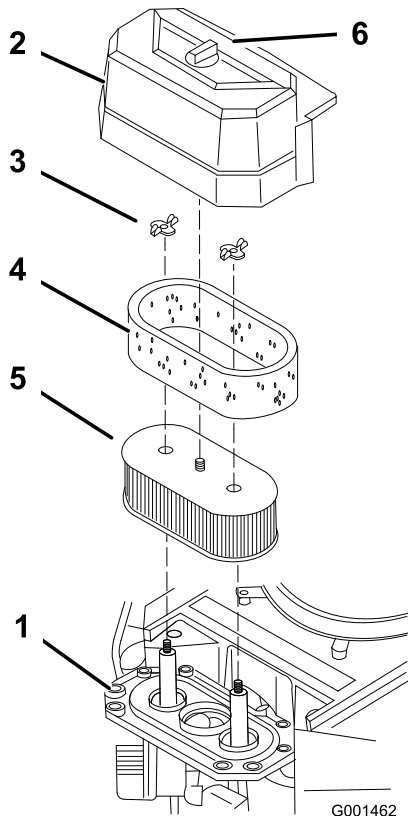

Figure 21

- |             |                  |
|-------------|------------------|
| 1. Engine   | 4. Foam element  |
| 2. Cover    | 5. Paper element |
| 3. Wing nut | 6. Cover knob    |

### Cleaning the Foam Air Cleaner Element

**Service Interval:** Every 25 hours (more often in dirty or dusty conditions).

**Important:** Do not oil the foam or paper element.

1. Wash the foam element in liquid soap and warm water. When the element is clean, rinse it thoroughly.
2. Dry the element by squeezing it in a clean cloth.

**Important:** Replace the foam element if it is torn or worn.

### Servicing the Paper Air Cleaner Element

**Service Interval:** Every 50 hours—Check the paper air filter (more often in dirty or dusty conditions).

Every 200 hours—Replace the paper air cleaner element (more often in dirty or dusty conditions).

1. Do not clean the paper filter. Replace it after 200 operating hours (Figure 21).
2. Inspect the element for tears, an oily film, or damage to the rubber seal.
3. Replace the paper element if it is damaged.

### Installing the Foam and Paper Elements

**Important:** To prevent engine damage, always operate the engine with the complete foam and paper air cleaner assembly installed.

1. Carefully slide the foam element onto the paper air cleaner element (Figure 21).
2. Place the air cleaner assembly onto the air cleaner base and secure it with the 2 wing nuts (Figure 21).
3. Place the air cleaner cover into position and tighten the cover knob (Figure 21).

### Servicing the Engine Oil

**Note:** Change the oil more frequently when the operating conditions are extremely dusty or sandy.

Oil Type: Detergent oil (API service SF, SG, SH, or SJ)

Crankcase Capacity: 58 ounces (1.7 liter) with the filter removed; 51 ounces (1.5 liter) without the filter removed

Viscosity: Refer to the table (Figure 22).

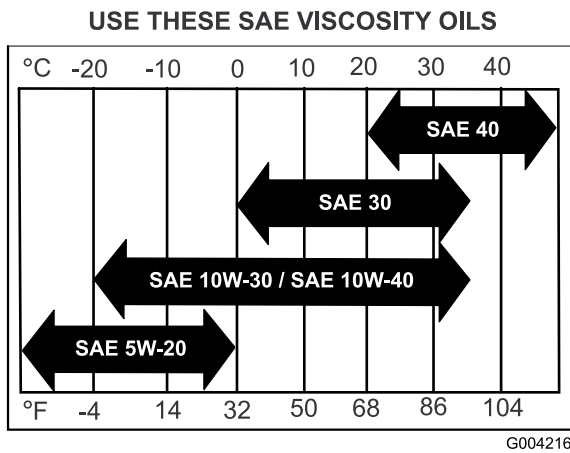
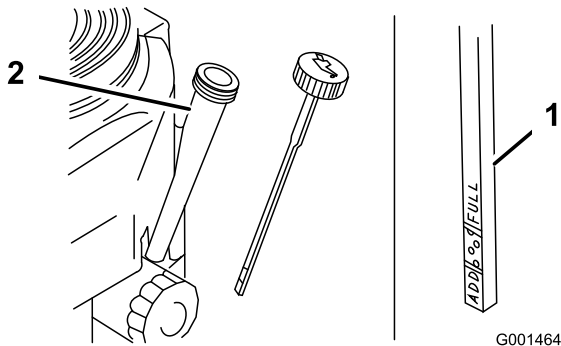

**Figure 22**

## Checking the Engine Oil Level

**Service Interval:** Before each use or daily

1. Park the machine on a level surface.
2. Disengage the PTO and set the parking brake.
3. Stop the engine, remove the key, and wait for all moving parts to stop before leaving the operating position.
4. Clean around the oil dipstick (Figure 23) so that dirt cannot fall into the filler hole and damage the engine.



**Figure 23**

1. Oil dipstick
2. Filler tube

5. Unscrew the oil dipstick and wipe the end clean (Figure 23).
6. Slide the oil dipstick fully into the filler tube, but do not thread onto tube (Figure 23).
7. Pull the dipstick out and look at the end. If the oil level is low, slowly pour only enough oil into the filler tube to raise the level to the Full mark.

**Important:** Do not overfill the crankcase with oil and run the engine; engine damage can result.

## Changing the Engine Oil

**Service Interval:** After the first 8 hours

Every 100 hours (more often in dirty or dusty conditions).

1. Start the engine and let it run five minutes. This warms the oil so it drains better.
2. Park the machine so that the drain side is slightly lower than the opposite side to assure the oil drains completely.
3. Disengage the PTO and set the parking brake.
4. Stop the engine, remove the key, and wait for all moving parts to stop before leaving the operating position.
5. Slide the drain hose over the oil drain valve.
6. Place a pan below the drain hose. Rotate oil drain valve to allow oil to drain (Figure 24).
7. When oil has drained completely, close the drain valve.
8. Remove the drain hose (Figure 24).

**Note:** Dispose of the used oil at a recycling center.

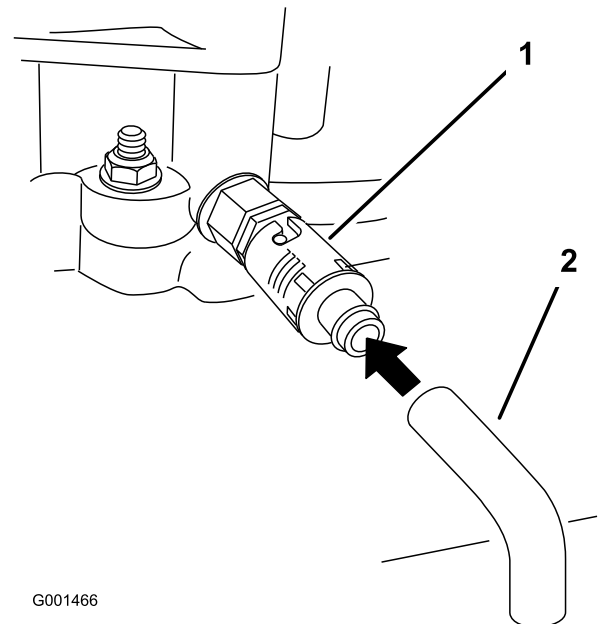

**Figure 24**

1. Oil drain valve
2. Oil drain hose

9. Slowly pour approximately 80% of the specified oil into the filler tube (Figure 23).
10. Check the oil level; refer to Checking the Engine Oil Level.
11. Slowly add the additional oil to bring it to the **Full** mark.

## Changing the Engine Oil Filter

**Service Interval:** Every 200 hours Or every other oil change.

**Note:** Change the oil filter more frequently when the operating conditions are extremely dusty or sandy.

1. Drain the oil from the engine; refer to Changing the Engine Oil.
2. Remove the old filter (Figure 25).

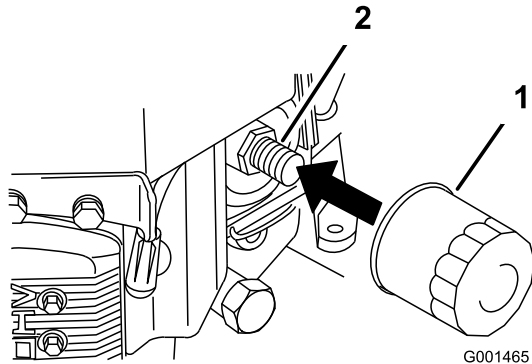

**Figure 25**

1. Oil filter
2. Adapter

3. Apply a thin coat of new oil to the rubber gasket on the replacement filter (Figure 25).
4. Install the replacement oil filter to the filter adapter, turn the oil filter clockwise until the rubber gasket contacts the filter adapter, then tighten the filter an additional 3/4 turn (Figure 25).
5. Fill the crankcase with the proper type of new oil; refer to Servicing the Engine Oil.
6. Run the engine for about 3 minutes, stop the engine, and check for oil leaks around the oil filter and drain valve.
7. Check the engine oil level and add oil if needed.
8. Wipe up any spilled oil.

## Servicing the Spark Plugs

Ensure that the air gap between the center and side electrodes is correct before installing the spark plug. Use a spark plug wrench for removing and installing the spark plugs and a gapping tool/feeler gauge to check and adjust the air gap. Install a new spark plugs if necessary.

Type: Champion® RCJ8Y or equivalent Air Gap: 0.030 inch (0.75 mm)

## Checking the Spark Plugs

**Service Interval:** Every 100 hours

1. Look at the center of the spark plugs (Figure 26). If you see light brown or gray on the insulator, the engine is operating properly. A black coating on the insulator usually means that the air cleaner is dirty.
2. If needed, clean the spark plug with a wire brush to remove carbon deposits.

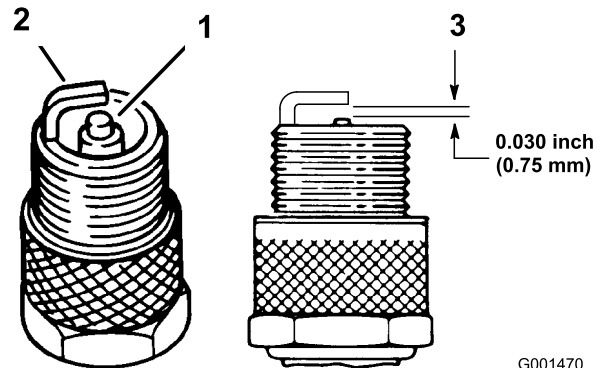

**Figure 26**

1. Center electrode insulator
2. Side electrode
3. Air gap (not to scale)

**Important:** Always replace the spark plugs when it has worn electrodes, an oily film on it, or has cracks in the porcelain.

3. Check the gap between the center and side electrodes (Figure 26). Bend the side electrode (Figure 26) if the gap is not correct.

## Removing the Spark Plugs

1. Disengage the PTO and set the parking brake.
2. Stop the engine, remove the key, and wait for all moving parts to stop before leaving the operating position.
3. Disconnect the wires from the spark plugs (Figure 27).

# Fuel System Maintenance

## Draining the Fuel Tank

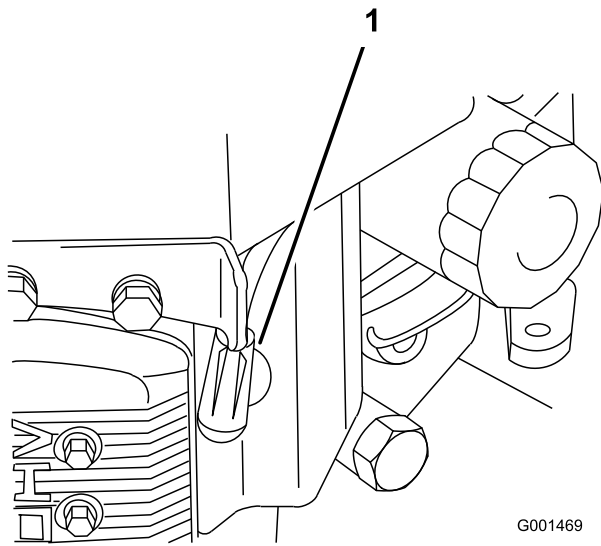

Figure 27

1. Spark-plug wire/spark plug

4. Clean around the spark plugs to prevent dirt from falling into the engine and potentially causing damage.
5. Remove the spark plugs and the metal washers.

### Installing the Spark Plugs

1. Install the spark plugs and the metal washer. Ensure that the air gap is set correctly.
2. Tighten the spark plugs to 16 ft-lb (22 N·m).
3. Connect the wires to the spark plugs (Figure 26).



In certain conditions, gasoline is extremely flammable and highly explosive. A fire or explosion from gasoline can burn you and others and can damage property.

- Drain gasoline from the fuel tank when the engine is cold. Do this outdoors in an open area. Wipe up any gasoline that spills.
- Never smoke when draining gasoline, and stay away from an open flame or where a spark may ignite the gasoline fumes.

1. Park the machine on a level surface, to assure fuel tank drains completely. Then disengage the power take off (PTO), set the parking brake, and turn the ignition key to **off**. Remove the key.
2. Close the fuel shut-off valve at the fuel tank (Figure 28).
3. Squeeze the ends of the hose clamp together and slide it up the fuel line away from fuel filter (Figure 28).
4. Pull the fuel line off the fuel filter (Figure 28). Open the fuel shut-off valve and allow the gasoline to drain into a gas can or drain pan.

**Note:** Now is the best time to install a new fuel filter because the fuel tank is empty. Refer to Replacing the Fuel Filter.

5. Install the fuel line onto the fuel filter. Slide the hose clamp close to the valve to secure the fuel line.
6. Wipe up any spilled fuel.

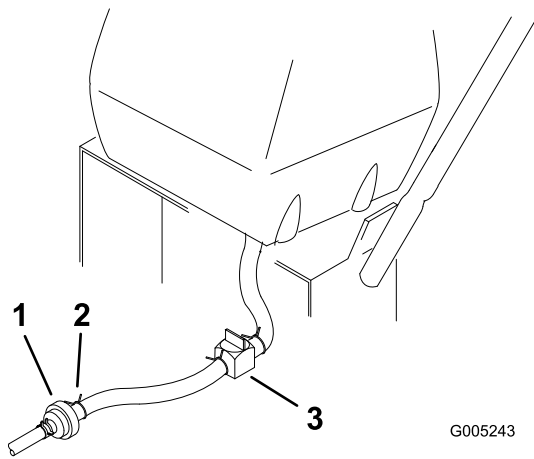

**Figure 28**

1. Fuel shut-off valve      2. Clamp

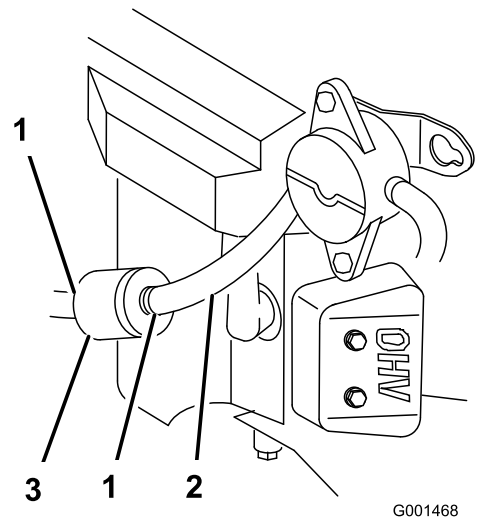

**Figure 29**

1. Hose clamp      3. Filter  
2. Fuel line

## Replacing the Fuel Filter

**Service Interval:** Every 200 hours or yearly, whichever occurs first.

Never install a dirty filter if it is removed from the fuel line.

**Note:** Note how the fuel filter is installed in order to install the new filter correctly.

**Note:** Wipe up any spilled fuel.

1. Disengage the PTO and set the parking brake.
2. Stop the engine, remove the key, and wait for all moving parts to stop before leaving the operating position.
3. Close fuel shut-off valve at the fuel tank (Figure 28).
4. Squeeze the ends of the hose clamps together and slide them away from the filter (Figure 29).

5. Remove the filter from the fuel lines.
6. Install a new filter and move the hose clamps close to the filter.
7. Open fuel shut-off valve at fuel tank (Figure 28).
8. Check for fuel leaks and repair if needed.
9. Wipe up any spilled fuel.

# Electrical System Maintenance

## Servicing the Fuses

The electrical system is protected by fuses. It requires no maintenance. If a fuse blows, check the component or circuit for a malfunction or short.

1. Remove the cover under the control panel.
2. Pull out on the fuse to remove or replace it (Figure 30).
3. Install the cover under the control panel.

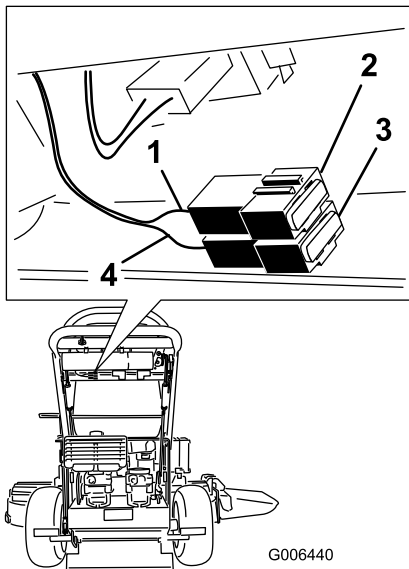

**Figure 30**

1. Fuse, 10 amp, blade type
2. Fuse, 20 amp, blade type

# Drive System Maintenance

## Adjusting the Tracking

1. If the machine does not track straight, adjustment is required.
2. Check the rear tire pressure. Refer to Checking the Tire Pressure.
3. Loosen the wing nuts on the right control rod and rotate the turnbuckle in or out to ensure the right side control lever is centered in the neutral lock position. Secure the turnbuckle in position with the wing nuts (Figure 31).
4. Loosen the wing nuts on the left control rod and rotate the turnbuckle in or out to change the tracking. Secure the turnbuckle in position with the wing nuts (Figure 31).
5. Check for proper tracking. Adjust the left control rod if a change is needed.

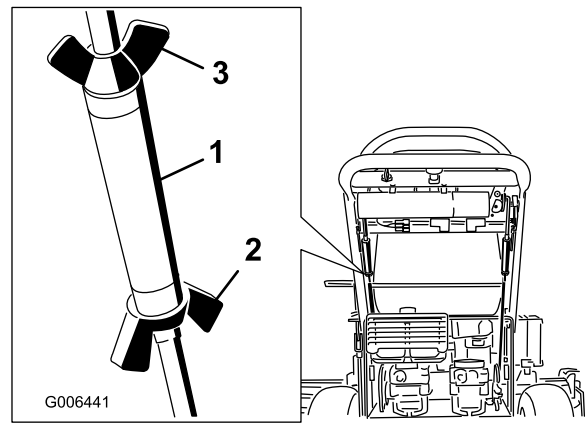

**Figure 31**

1. Turnbuckle
2. Bottom wing nut
3. Top wing nut (left hand threaded)

## Checking the Tire Pressure

**Service Interval:** Every 50 hours or monthly, whichever occurs first.

Check the pressure at the valve stem (Figure 32).

Maintain the air pressure in the rear tires at 12-14 psi (83-97 kPa). Uneven tire pressure can cause an uneven cut.

**Note:** The front tires are semi-pneumatic tires and do not require air pressure maintenance.

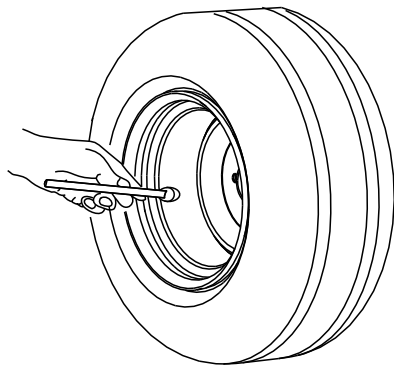

G001055

Figure 32

## Replacing the Caster Wheel Fork Bushings

The caster wheel forks are mounted in bushings pressed into the top and bottom of the carrier frame mounting pivot tubes. To check the bushings, move the caster forks back and forth and side-to-side. If a caster fork is loose, the bushings are worn and must be replaced.

1. Raise the cutting unit so the caster wheels are off the floor, then support the front of the mower with jack stands.
2. Remove the locking pin and spacer(s) from the top of the caster wheel fork (Figure 33).

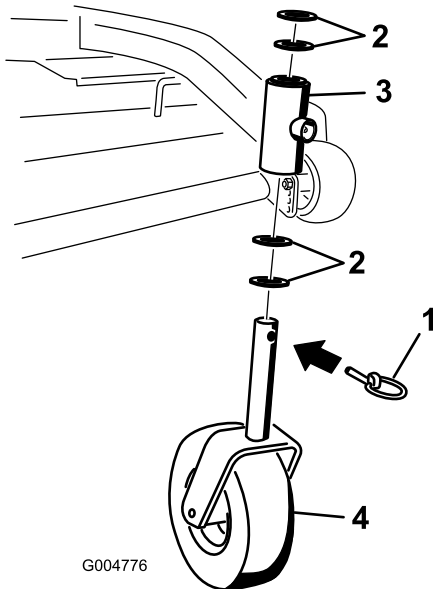

G004776

Figure 33

- |                |                             |
|----------------|-----------------------------|
| 1. Locking Pin | 3. Carrier frame pivot tube |
| 2. Spacers     | 4. Caster wheel fork        |

3. Pull the caster wheel fork out of the mounting tube, leaving the spacer(s) on the bottom of the fork. Remember the location of the spacers on each fork

to ensure correct installation, and to maintain a level deck.

4. Insert a pin punch into the mounting tube and carefully drive out the bushings (Figure 34). Clean the inside of the mounting tube.

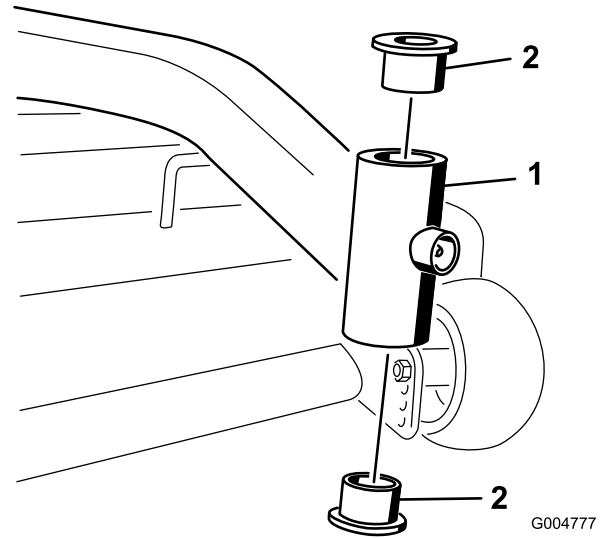

G004777

Figure 34

- |                  |            |
|------------------|------------|
| 1. Mounting Tube | 2. Bushing |
|------------------|------------|

5. Grease the inside and outside of the new bushings. Use a hammer and flat plate to carefully drive the bushings into the pivot tubes.
6. Inspect the caster wheel fork for wear and replace if necessary (Figure 33).
7. Slide the caster wheel fork through the bushings in the mounting tube. Replace the spacer(s) onto the fork and secure with the retaining ring (Figure 33).

**Important:** The inside diameter of the bushings may collapse slightly when installed. If the caster wheel fork does not slide into the new bushings, ream both bushings to an inside diameter of 1.126 inch (29 mm).

8. Grease the fitting on the carrier frame pivot tubes using No. 2 general purpose lithium base or molybdenum base grease.

## Servicing the Caster Wheel and Bearings

The caster wheels rotate on a roller bearing supported by a spanner bushing. If the bearing is kept well lubricated, wear will be minimal. Failure to keep the bearing well lubricated will cause rapid wear. A wobbly caster wheel usually indicates a worn bearing.

1. Remove the locknut and wheel bolt holding the caster wheel to the caster fork (Figure 35).

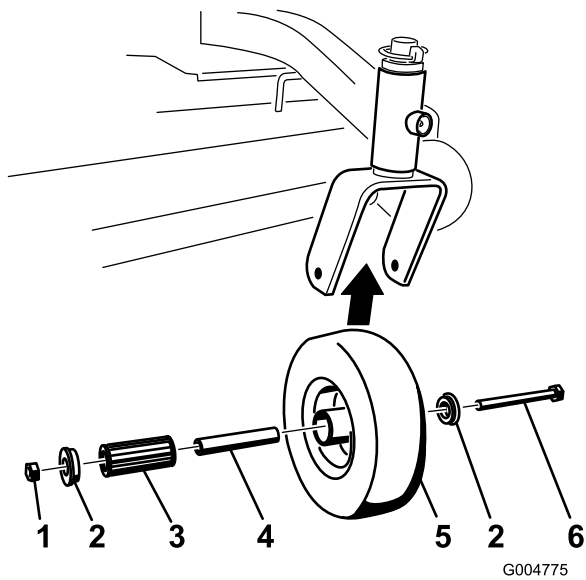

**Figure 35**

- |               |                    |
|---------------|--------------------|
| 1. Locknut    | 4. Spanner Bushing |
| 2. Wheel Bolt | 5. Roller Bearing  |
| 3. Bushing    |                    |

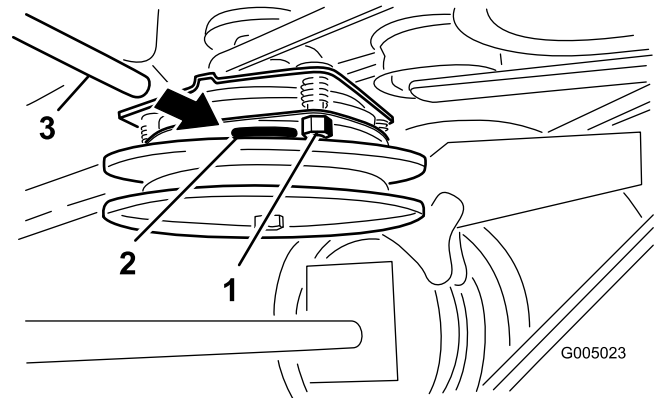

**Figure 36**

- |                  |                 |
|------------------|-----------------|
| 1. Adjusting nut | 3. Feeler gauge |
| 2. Slot          |                 |

2. Remove one bushing, then pull the spanner bushing and roller bearing out of the wheel hub (Figure 35).
3. Remove the other bushing from the wheel hub and clean any grease and dirt from the wheel hub (Figure 35).
4. Inspect the roller bearing, bushings, spanner bushing and inside of the wheel hub for wear. Replace any defective or worn parts (Figure 35).
5. To assemble, place one bushing into the wheel hub. Grease the roller bearing and spanner bushing and slide them into the wheel hub. Place the second bushing into the wheel hub (Figure 35).
6. Install the caster wheel into the caster fork and secure with the wheel bolt and locknut. Tighten the locknut until the spanner bushing bottoms against the inside of the caster forks (Figure 35).
7. Grease the fitting on the caster wheel.

## Adjusting the Electric Clutch

**Service Interval:** Every 100 hours

The clutch is adjustable to ensure proper engagement and proper braking.

1. Insert a 0.015–0.021 inch (0.381–0.533 mm) feeler gauge through one inspection slot in the side of the assembly. Make sure it is between the armature and the rotor friction surfaces.
2. Tighten the lock nuts until there is slight binding on the feeler gauge but it can be moved easily within the air gap (Figure 36).

# Cooling System Maintenance

## Cleaning the Air Intake Screen

**Service Interval:** Before each use or daily

Remove any build-up of grass, dirt or other debris from the cylinder and cylinder head cooling fins, air intake screen on flywheel end, and carburetor-governor levers and linkage. This will help insure adequate cooling and correct engine speed and will reduce the possibility of overheating and mechanical damage to the engine.

# Brake Maintenance

## Servicing the Brake

Always set the parking brake when you stop the machine or leave it unattended. If the parking brake does not hold securely, an adjustment is required.

## Checking the Parking Brake

**Service Interval:** Before each use or daily

Check the brakes on both a level surface and slope.

1. Park the machine on a level surface, disengage the PTO.
2. Stop the engine, remove the key, and wait for all moving parts to stop before leaving the operating position.
3. Apply the parking brake. Setting the parking brake should take a reasonable amount of force. If the parking brake does not hold securely, an adjustment is required. Refer to Adjusting the Parking Brake.

**Note:** When the brake is engaged, the brake handle should be in the 1 o'clock position (Figure 37).

## Adjusting the Brakes

If the parking brake does not hold securely, an adjustment is required.

1. Park the machine on a level surface, disengage the PTO, and set the parking brake.
2. Stop the engine, remove the key, and wait for all moving parts to stop before leaving the operating position.
3. Check the brake before you adjust it; refer to Checking the Brakes.
4. Release the parking brake; refer to Releasing the Parking Brake in Operation , page 12.
5. Loosen the top and bottom jam nuts (Figure 37).
6. To adjust the brake, remove the hair pin cotter and clevis pin from the lower brake lever (Figure 37).
7. Rotate the brake rod in the yokes. To tighten the brake, lengthen the rod between the yokes. To loosen the brake, shorten the rod between the yokes (Figure 37).

**Note:** The brake rod should be threaded into both yokes the same distance.

8. Secure the yoke to lower brake lever with the hair pin cotter and clevis pin (Figure 37).

9. Tighten the top and bottom jam nuts (Figure 37).
10. Check the brake operation again; refer to Checking the Brake.

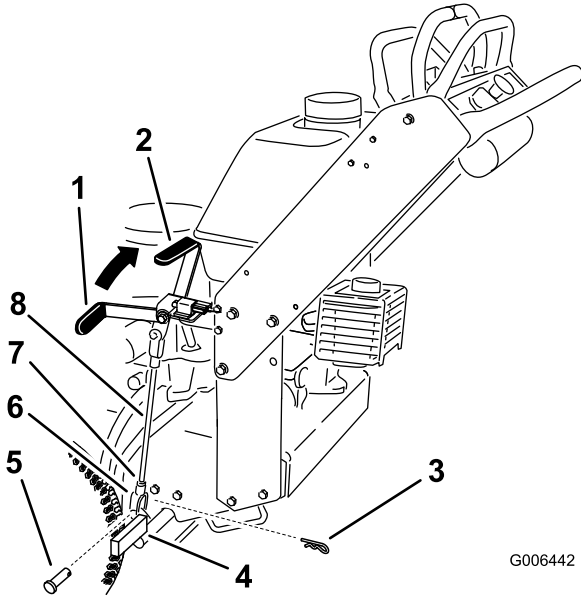

**Figure 37**

- |  |               |
|--|---------------|
| 1. Parking brake lever (released position) | 5. Clevis pin |
| 2. 1 o'clock position                      | 6. Yoke       |
| 3. Haripin cotter                          | 7. Jam Nut    |
| 4. Lower brake lever                       | 8. Brake rod  |

# Belt Maintenance

## Inspecting the Belts

**Service Interval:** Every 50 hours

Squealing when the belt is rotating, blades slipping when cutting grass, frayed belt edges, burn marks and cracks are signs of a worn belt. Replace the belt if any of these conditions are evident.

## Replacing the Mower Belt

1. Disengage the PTO and set the parking brake.
2. Stop the engine, remove the key, and wait for all moving parts to stop before leaving the operating position.
3. Unlatch and remove the carrier frame cover.
4. Unlatch and remove the belt covers.
5. Remove the PTO drive belt. Refer to Replacing the PTO Drive Belt.
6. Disconnect the idler arm spring to relieve tension on the idler arm and idler pulley, then remove the worn mower belt (Figure 38).
7. Install the new mower belt around the two outside spindle pulleys, the idler pulley, and in the lower groove of the double spindle pulley (Figure 38).
8. Connect the idler arm spring (Figure 38).
9. Install the PTO drive belt. Refer to Replacing the PTO Drive Belt.
10. Adjust the belt guide an 1/8 inch (3 mm) from the belt (Figure 38).
11. Install the belt covers onto the cutting unit and secure the latches.
12. Install the carrier frame cover onto the cutting unit and secure the latches.

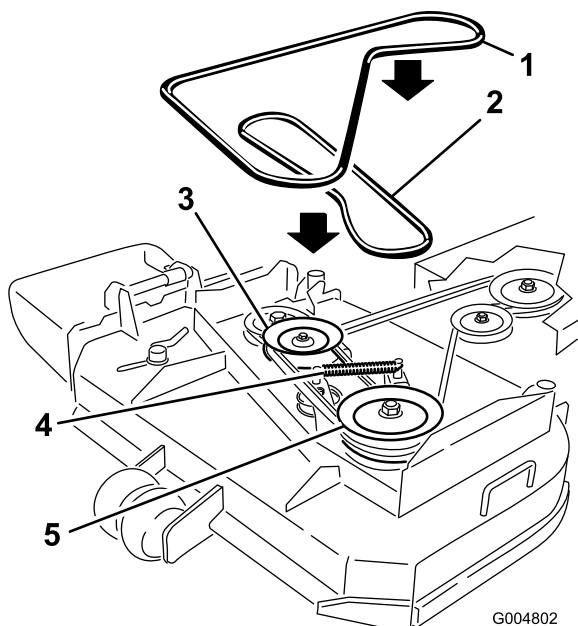

**Figure 38**

- |                      |                      |
|----------------------|----------------------|
| 1. Mower deck belt   | 4. Idler arm spring  |
| 2. PTO Drive Belt    | 5. Drive belt pulley |
| 3. Drive belt pulley |                      |

## Replacing the PTO Drive Belt

1. Disengage the PTO and set the parking brake.
2. Stop the engine, remove the key, and wait for all moving parts to stop before leaving the operating position.
3. Unlatch and remove the carrier frame cover.
4. Unlatch and remove the belt covers.
5. Remove the heat shield from the engine deck and carrier frame.
6. Roll the belt off of the center pulley on the mower deck (Figure 39). Use caution when removing the belt as tension will increase because of the spring loaded idler pulley.
7. Remove the belt from the engine pulley and the spring loaded idler pulley (Figure 39).
8. Install the new belt onto the engine pulley and spring loaded idler pulley (Figure 39).
9. Roll the belt onto the center pulley on the mower deck (Figure 39). Use caution when install the belt as tension will increase because of the spring loaded idler pulley.
10. Install the heat shield to the engine deck and carrier frame.

11. Install the belt covers onto the cutting unit and secure the latches.
12. Install the carrier frame cover onto the carrier frame and secure the latches.

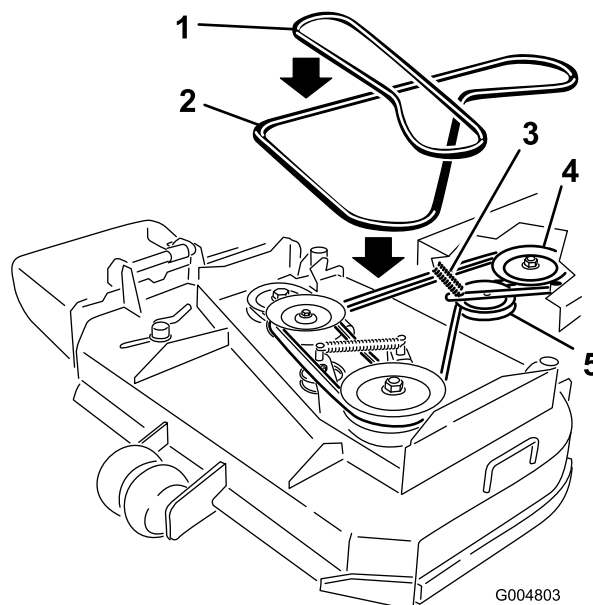

**Figure 39**

- |                         |                  |
|-------------------------|------------------|
| 1. Mower deck belt      | 4. Clutch pulley |
| 2. PTO Drive Belt       | 5. Idler pulley  |
| 3. Idler arm and spring |                  |

## Adjusting the PTO Drive Belt Idler Spring Anchor

The position of the PTO idler can be adjusted to increase or decrease belt tension.

Use Figure 40 for the idler position options.

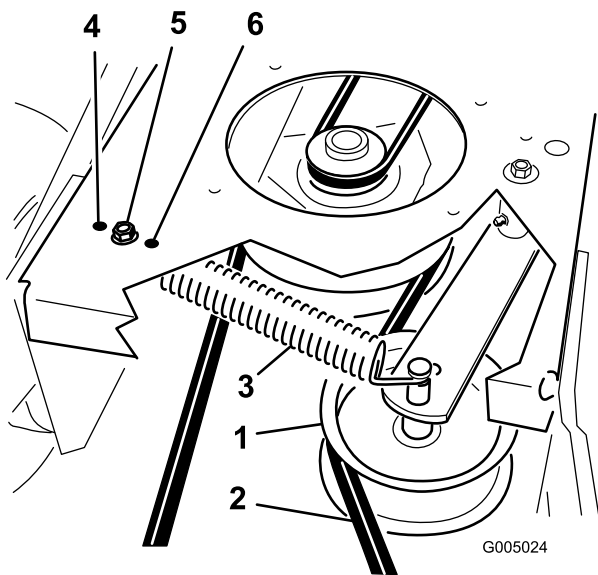

**Figure 40**

- |                                |  |
|--------------------------------|--|
| 1. PTO drive belt idler pulley | 4. Most tension for worn belts               |
| 2. PTO drive Belt              | 5. Medium tension for normal belt conditions |
| 3. Idler spring                | 6. Least tension for new belts               |

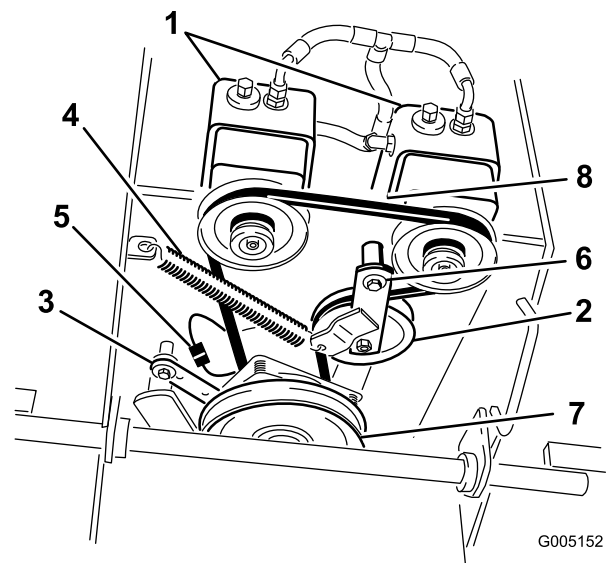

**Figure 41**

- |                    |                          |
|--------------------|--------------------------|
| 1. Hydraulic pumps | 5. Clutch wire connector |
| 2. Idler pulley    | 6. Pivot bolt            |
| 3. Clutch retainer | 7. Drive pulley          |
| 4. Tension spring  | 8. Pump drive belt       |

## Replacing the Pump Drive Belt

1. Disengage the PTO and set the parking brake.
2. Stop the engine, remove the key, and wait for all moving parts to stop before leaving the operating position.
3. Remove PTO drive belt. Refer to Replacing the PTO Drive Belt in the Belt Maintenance , page 33.
4. Raise the machine and support it with jack stands.
5. Disconnect the clutch wire connector from the wire harness.
6. Disconnect the clutch retainer from the engine deck (Figure 41).

7. Unhook the idler spring from the frame (Figure 41).
8. Install the new belt around clutch and the two drive pulleys.
9. Install the idler spring between idler arm and frame bracket (Figure 41).
10. Install the clutch retainer to the engine deck (Figure 41).
11. Connect the clutch wire connector to the wire harness.
12. Install the PTO drive belt.

# Controls System Maintenance

## Adjusting the Motion Control Handle Positions

### Adjusting the Right Side Motion Control Lever

If the motion control levers do not align horizontally, adjust the right side motion control lever.

**Note:** Adjust the horizontal alignment before the front to back alignment.

1. Disengage the PTO, move the right side motion control lever to the neutral position and set the parking brake.
2. Stop the engine, remove the key, and wait for all moving parts to stop before leaving the operating position.
3. Push the right motion control lever down out of locked neutral position (Figure 42).
4. Check if it aligns horizontally with the left motion control lever (Figure 42).

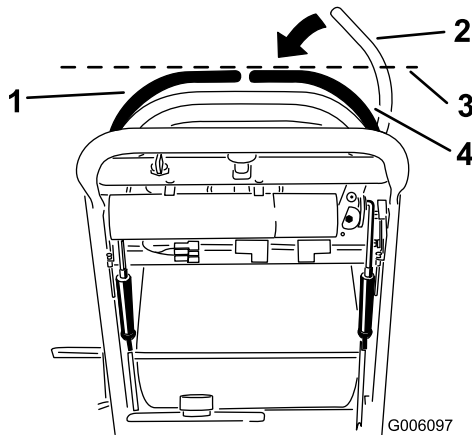

**Figure 42**

- |  |  |
|--|--|
| 1. Left motion control lever                             | 3. Check the horizontal alignment here |
| 2. Right motion control lever in neutral locked position | 4. Right motion control lever          |

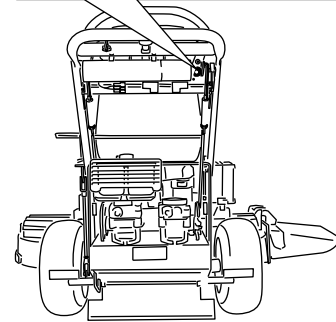
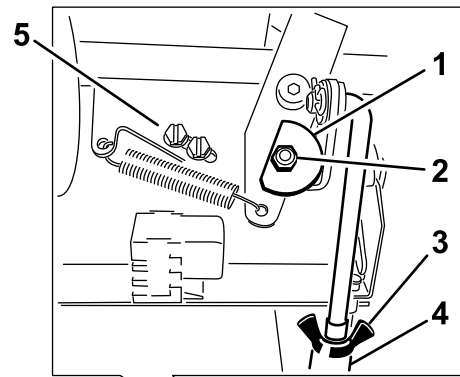

G006443

**Figure 43**

- |                 |                  |
|-----------------|------------------|
| 1. Cam          | 4. Turnbuckle    |
| 2. Nut and bolt | 5. Switch screws |
| 3. Wing nut     |                  |

9. After the cam is adjusted, the lever switch needs to be checked.
10. Check the gap between the control lever and switch as shown in Figure 44. The gap needs to be an 1/8 inch (3mm).
11. If needed, loosen the screws holding the switch and adjust the switch.
12. Tighten the screws and install the cover under the control panel.

5. To adjust the right motion control lever horizontally, the cam needs to be adjusted.
6. Remove the cover under the control panel.
7. Loosen the nut and bolt holding the cam (Figure 43).
8. Adjust the cam until it aligns with the left motion control lever and tighten the nut and bolt for the cam.

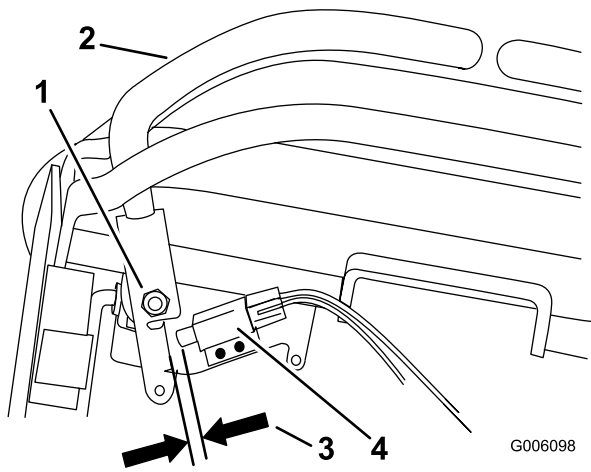

**Figure 44**

- |   |   |
|---|---|
| 1. Right side motion control lever pivot shown under controls | 3. 1/8 inch (3mm) gap needed between switch and control lever |
| 2. Right side motion control lever                            | 4. Switch   |

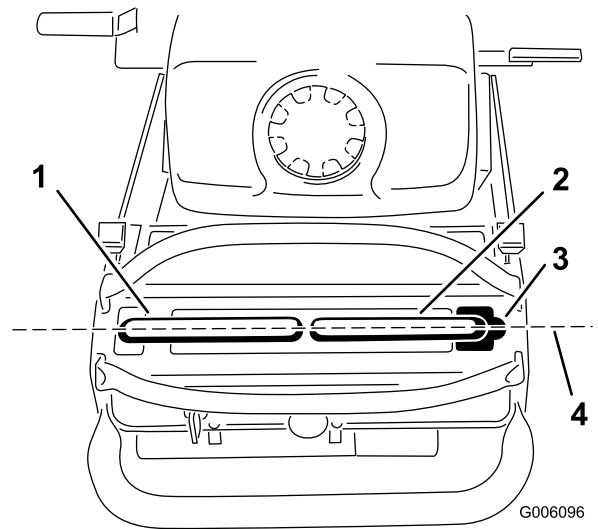

**Figure 45**

- |                               |  |
|-------------------------------|--|
| 1. Left motion control lever  | 3. Neutral locked position                     |
| 2. Right motion control lever | 4. Align the control levers front to back here |

## Adjusting the Neutral Position for the Motion Control Levers

**Important:** Ensure the tracking of the mower is correct after adjusting the motion control levers. After adjusting the tracking, the motion control levers may not align the exactly front to back (Figure 45).

If the motion control levers do not align front to back, or the right side control lever does not move easily into the neutral lock position, adjustment is required. Adjust each lever and control rod separately.

**Note:** Adjust the horizontal alignment before the front to back alignment.

1. After the horizontal alignment is finished, check the front to back alignment (Figure 45).

2. Loosen the wing nuts on the right control rod and rotate the turnbuckle in or out to ensure the right side control lever is centered in the neutral lock position. Secure the turnbuckle in position with the wing nuts (Figure 46).
3. Loosen the wing nuts on the left control rod and rotate the turnbuckle in or out to change the tracking. Secure the turnbuckle in position with the wing nuts (Figure 46).

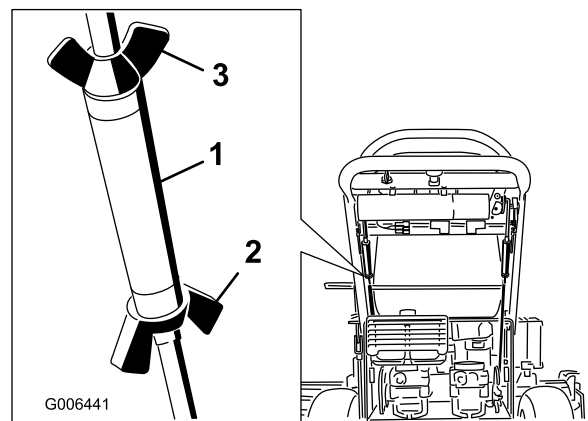

**Figure 46**

- |                    |                                      |
|--------------------|--------------------------------------|
| 1. Turnbuckle      | 3. Top wing nut (left hand threaded) |
| 2. Bottom wing nut |                                      |

4. Check for proper tracking. Adjust the left control rod if a change is needed. Refer to Adjusting the Tracking in the Operation Section.

# Hydraulic System Maintenance

## Servicing the Hydraulic System

Fluid Type: Mobil 1 15W-50 synthetic motor oil or equivalent synthetic oil.

**Important:** Use oil specified or equivalent. Other fluids could cause system damage.

Hydraulic System Oil Capacity: 67 oz. (2.0 l)

### Checking the Hydraulic Fluid

**Service Interval:** After the first 8 hours—Check the hydraulic fluid.

Every 25 hours—Check the hydraulic fluid.

**Note:** There are two ways of checking the hydraulic oil. One is when the oil is warm and one is when the oil is cold. The baffle inside the tank has two levels depending if the oil is warm or cold.

1. Position machine on a level surface.
2. Disengage the power take off (PTO) and shut off the engine.
3. Wait for all moving parts to stop before leaving the operating position and then set the parking brake.
4. Clean area around cap and filler neck of hydraulic tank (Figure 47).

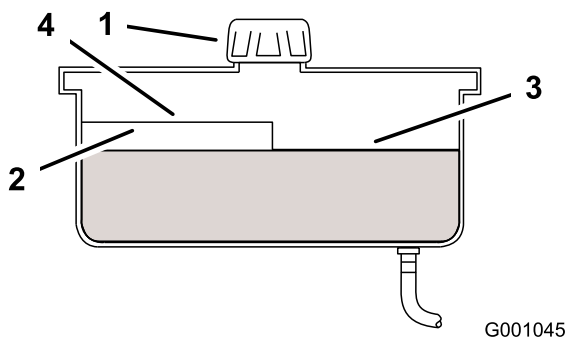

Figure 47

- |           |                          |
|-----------|--------------------------|
| 1. Cap    | 3. Cold fluid level-full |
| 2. Baffle | 4. Hot fluid level-full  |

5. Remove cap from filler neck. Look inside to check the fluid level in the reservoir. (Figure 47).
6. Add fluid to the reservoir until it reaches the cold level of the baffle.

7. Run the machine at low idle for 15 minutes to allow any air to purge out of the system and warm fluid. Refer to Starting and Stopping the Engine.
8. Recheck the fluid level while the fluid is warm. If required, add fluid to the reservoir until it reaches the hot level of the baffle.

**Note:** The fluid level should be to the top of the hot level of the baffle, when the fluid is warm (Figure 47).

9. Install cap on filler neck.



**Hydraulic fluid escaping under pressure can penetrate skin and cause injury.**

- If hydraulic fluid is injected into the skin it must be surgically removed within a few hours by a doctor familiar with this type of injury. Gangrene may result if this is not done.
- Keep body and hands away from pin hole leaks or nozzles that eject high pressure hydraulic fluid.
- Use cardboard or paper to find hydraulic leaks.
- Safely relieve all pressure in the hydraulic system before performing any work on the hydraulic system.
- Make sure all hydraulic fluid hoses and lines are in good condition and all hydraulic connections and fittings are tight before applying pressure to hydraulic system.

### Replacing the Hydraulic Filter

**Service Interval:** After the first 8 hours—Change the hydraulic filter.

Every 200 hours—Change the hydraulic filter.



**Hot hydraulic fluid can cause severe burns.**

**Allow the hydraulic fluid to cool before performing any maintenance to the hydraulic system.**

1. Disengage the PTO and set the parking brake.
2. Stop the engine and wait for all moving parts to stop before leaving the operating position.

**Important:** Do not substitute automotive oil filter or severe hydraulic system damage may result.

3. Remove hydraulic reservoir cap and temporarily cover opening with a plastic bag and rubber band to prevent all hydraulic fluid from draining out.
4. Locate the filter under the fuel tank and place drain pan under filter (Figure 48).

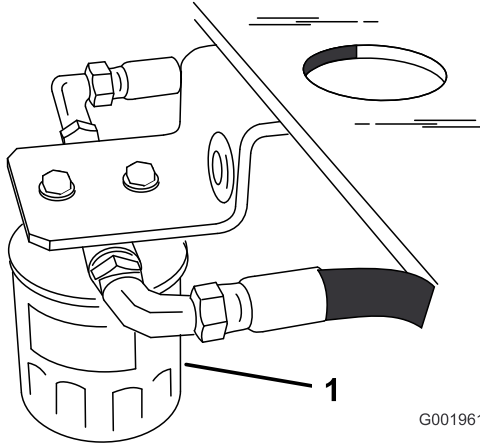

**Figure 48**

5. Remove the old filter and wipe the filter adapter gasket surface clean (Figure 49).
6. Apply a thin coat hydraulic fluid to the rubber gasket on the replacement filter.
7. Install replacement hydraulic filter onto the filter adapter. Do not tighten.
8. Remove plastic bag from reservoir opening and allow filter to fill with hydraulic fluid.
9. When the hydraulic filter is full, turn the oil filter clockwise until the rubber gasket contacts the filter adapter, then tighten the filter an additional 1/2 turn (Figure 49).

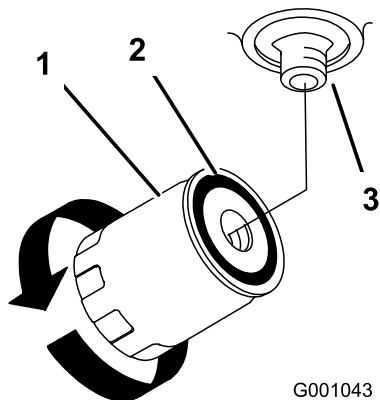

**Figure 49**

- |                     |            |
|---------------------|------------|
| 1. Hydraulic filter | 3. Adapter |
| 2. Gasket           |            |

10. Clean up any spilled fluid.

11. Check the fluid in the reservoir, add fluid to the tank until it reaches the cold baffle of the tank.

**Important:** Use oil specified or equivalent. Other fluids could cause system damage.

12. Start engine and let run for about two minutes to purge air from the system. Stop the engine and check for leaks. If one or both wheels will not drive, refer to Bleeding Hydraulic System.

13. Recheck level and add fluid, if required. **Do not overfill.**

## Bleeding the Hydraulic System

The traction system is self bleeding, however, it may be necessary to bleed the system if fluid is changed or after work is performed on the system.

1. Disengage the PTO and set the parking brake.
2. Stop the engine and wait for all moving parts to stop before leaving the operating position.
3. Raise the rear of the machine up onto jack stands high enough to raise the drive wheels off the ground.
4. Start the engine and move the throttle control to idle position.

If the drive wheel does not rotate, it is possible to assist the purging of the system by carefully rotating the tire in the forward direction.

5. Check the hydraulic fluid level as it drops add fluid as required to maintain the proper level.
6. Repeat this procedure for the opposite wheel.
7. Thoroughly clean the area around each of the charge pump housings.

## Checking the Hydraulic Lines

**Service Interval:** Every 100 hours

Check hydraulic lines and hoses for leaks, loose fittings, kinked lines, loose mounting supports, wear, weather and chemical deterioration. Make necessary repairs before operating.

**Note:** Keep areas around hydraulic system clean from grass and debris build up.



Hydraulic fluid escaping under pressure can penetrate skin and cause injury.

- If hydraulic fluid is injected into the skin it must be surgically removed within a few hours by a doctor familiar with this type of injury. Gangrene may result if this is not done.
- Keep body and hands away from pin hole leaks or nozzles that eject high pressure hydraulic fluid.
- Use cardboard or paper to find hydraulic leaks.
- Safely relieve all pressure in the hydraulic system before performing any work on the hydraulic system.
- Make sure all hydraulic fluid hoses and lines are in good condition and all hydraulic connections and fittings are tight before applying pressure to hydraulic system.

## **Mower Deck Maintenance**

### **Servicing the Cutting Blades**

To ensure a superior quality of cut, keep the blades sharp. For convenient sharpening and replacement, you may want to keep extra blades on hand.



**A worn or damaged blade can break, and a piece of the blade could be thrown into the operator's or bystander's area, resulting in serious personal injury or death.**

- Inspect the blades periodically for wear or damage.
- Replace a worn or damaged blade.

### **Before Inspecting or Servicing the Blades**

Park the machine on a level surface, disengage the blades and set the parking brake. Turn the ignition key to off. Remove the key and disconnect the spark plug wires from the spark plugs.

### **Inspecting the Blades**

1. Inspect the cutting edges (Figure 50). If the edges are not sharp or have nicks, remove and sharpen the blades. Refer to Sharpening the Blades.

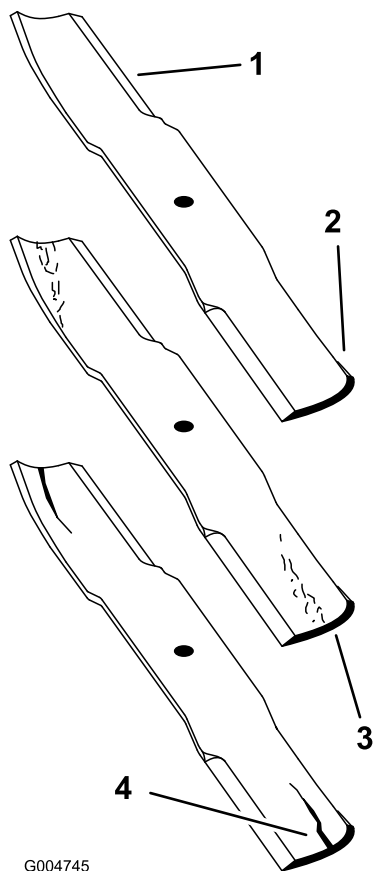

G004745

**Figure 50**

- |                 |                                     |
|-----------------|-------------------------------------|
| 1. Cutting Edge | 3. Wear/slot forming in curved area |
| 2. Sail         | 4. Crack in the curved area         |

2. Inspect the blades, especially the curved area (Figure 50). If you notice any cracks, wear, or a slot forming in this area (item 3 in Figure 50), immediately install a new blade.

## Checking for Bent Blades

1. Disengage the PTO, move the motion control levers to the neutral locked position and set the parking brake.
2. Stop the engine, remove the key, and wait for all moving parts to stop before leaving the operating position.
3. Rotate the blades until the ends face forward and backward. Measure from a level surface to the cutting edge, position **A**, of the blades (Figure 51).

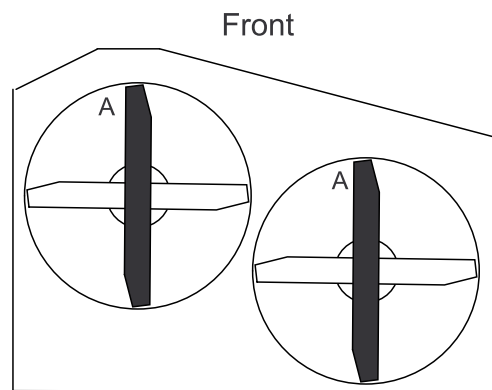

G000288

**Figure 51**

4. Rotate the opposite ends of the blades forward.
5. Measure from a level surface to the cutting edge of the blades at the same position as in step 3 above. The difference between the dimensions obtained in steps 3 and 4 must not exceed 1/8 inch (3 mm). If this dimension exceeds 1/8 inch (3 mm), the blade is bent and must be replaced; refer to Removing the Blades and Installing the Blades.



**A blade that is bent or damaged could break apart and could seriously injure or kill you or bystanders.**

- **Always replace bent or damaged blade with a new blade.**
- **Never file or create sharp notches in the edges or surfaces of blade.**

## Removing the Blades

Blades must be replaced if a solid object is hit, if the blade is out of balance or is bent. To ensure optimum performance and continued safety conformance of the machine, use genuine Toro replacement blades. Replacement blades made by other manufacturers may result in non-conformance with safety standards.

1. Hold the blade end using a rag or thickly-padded glove.
2. Remove the blade bolt, curved washer, blade stiffener, and blade from the spindle (Figure 52).

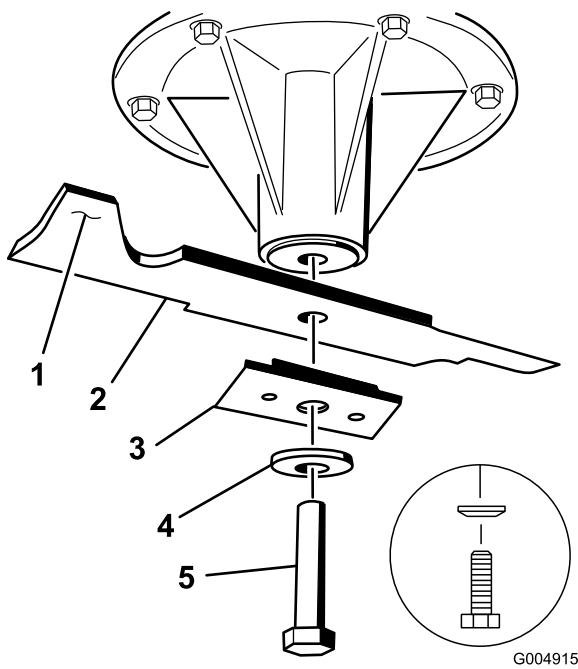

Figure 52

- |                       |                  |
|-----------------------|------------------|
| 1. Sail Area of Blade | 4. Curved washer |
| 2. Blade              | 5. Blade Bolt    |
| 3. Blade stiffener    |                  |

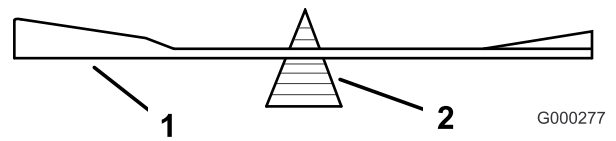

Figure 54

- |          |             |
|----------|-------------|
| 1. Blade | 2. Balancer |
|----------|-------------|

## Sharpening the Blades

1. Use a file to sharpen the cutting edge at both ends of the blade (Figure 53). Maintain the original angle. The blade retains its balance if the same amount of material is removed from both cutting edges.

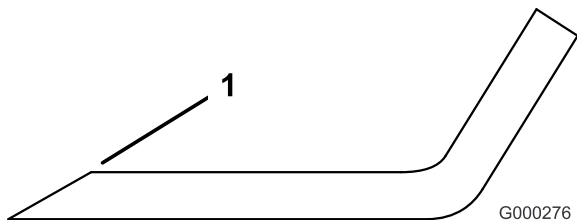

Figure 53

1. Sharpen at original angle
- 
2. Check the balance of the blade by putting it on a blade balancer (Figure 54). If the blade stays in a horizontal position, the blade is balanced and can be used. If the blade is not balanced, file some metal off the end of the sail area only (Figure 52). Repeat this procedure until the blade is balanced.

## Installing the Blades

**Important:** The sail part of the blade must be pointing upward, toward the inside of the mower to ensure proper cutting (Figure 52).

1. Install the blade, stiffener, curved washer, and blade bolt to the spindle (Figure 52).
2. Torque the blade bolt to 85-110 ft-lb (115-140 N-m).

## Correcting the Mower Quality of Cut

If one deck blade cuts lower than the other, correct as follows.

**Note:** Tire air pressure is critical in these procedures. Make sure all tires have correct pressure.

1. Disengage the PTO and set the parking brake.
2. Stop the engine, remove the key, and wait for all moving parts to stop before leaving the operating position. Disconnect the spark plug wire(s) from the spark plug(s).
3. Adjust the tire pressure in the rear tires to specifications; refer to Drive System Maintenance , page 29 .
4. Check that the blades and spindle shafts are not bent. Refer to Checking for Bent Blades.
5. Set the height-of-cut to the 4 inch (101.6 mm) position. Refer to Adjusting the Height-Of-Cut in Operation , page 12.
6. Perform the steps in the following sections Frame Set Up, Checking Front-to-Rear Pitch, and Checking Side-to-Side Leveling.

## Frame Set Up

### Checking the Carrier Frame and Engine Deck Alignment

**Note:** Misalignment can cause excess wear on the PTO drive belt.

1. Disengage the PTO and set the parking brake.

2. Stop the engine, remove the key, and wait for all moving parts to stop before leaving the operating position.
3. Place a long straight edge on top of the engine deck as shown in Figure 55.
4. At the carrier frame cross channel, measure the height at location **A** (Figure 55). This measurement must be 1-5/16 inch (33 mm), plus or minus a 1/4 inch (6 mm).
5. If the height at location **A** is not correct, adjustment is needed.
6. Loosen the carrier frame mounting bolts on both sides of the machine (Figure 55).
7. Align the carrier frame and engine deck to match 1-5/16 inch (33 mm), plus or minus a 1/4 inch (6 mm) at location **A** (Figure 55).
8. Tighten the carrier frame mounting bolts on both sides of the machine.

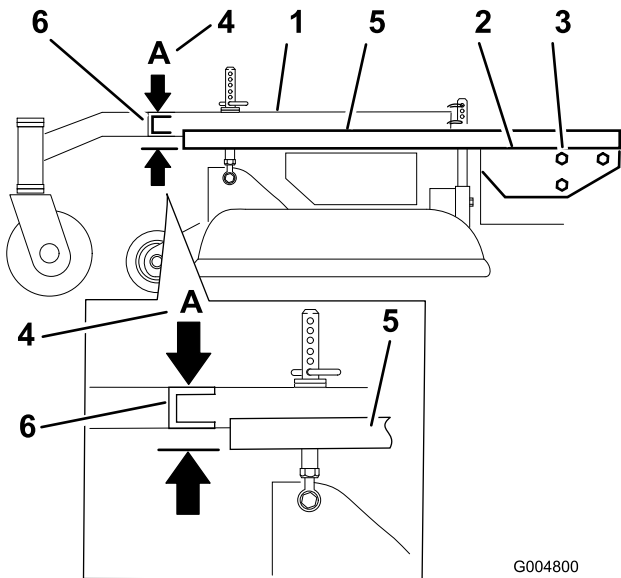

**Figure 55**

- |                                 |   |
|---------------------------------|---|
| 1. Carrier Frame                | 4. Location A, 1-5/16 inch (33 mm) ±1/4 inch (6 mm) |
| 2. Top of engine deck           | 5. Straight edge                                    |
| 3. Carrier frame mounting bolts | 6. Carrier frame cross channel                      |

## Checking the Engine Deck Height

1. Disengage the PTO and set the parking brake.
2. Stop the engine, remove the key, and wait for all moving parts to stop before leaving the operating position.
3. Adjust the tire pressure in the rear tires to specifications; refer to Drive System Maintenance , page 29 .

4. Measure engine deck height at location **A** (Figure 56).
5. Measure engine deck height at location **B** (Figure 56).
6. If the height at location **A** and **B** are not the same, change tire pressure slightly to make them the same.

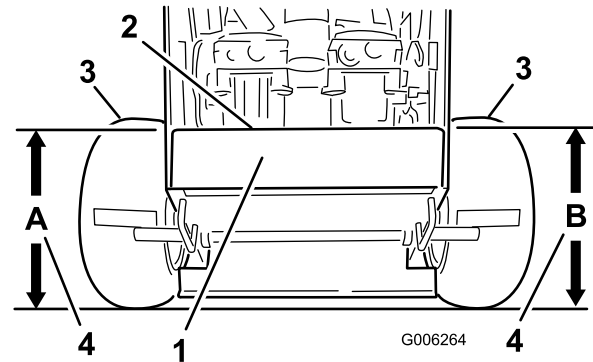

**Figure 56**

- |                         |                                     |
|-------------------------|-------------------------------------|
| 1. Back view of machine | 3. Tires                            |
| 2. Top of engine deck   | 4. Same height at locations A and B |

## Checking the Carrier Frame Front-to-Rear Pitch

The carrier frame must have a pitch between 1/8 inch (3 mm) to 3/8 inch (9 mm) over the length of 24 inches (61 cm) on the carrier frame (Figure 57).

1. Measure out 24 inches (61 cm) on the carrier frame (Figure 57).

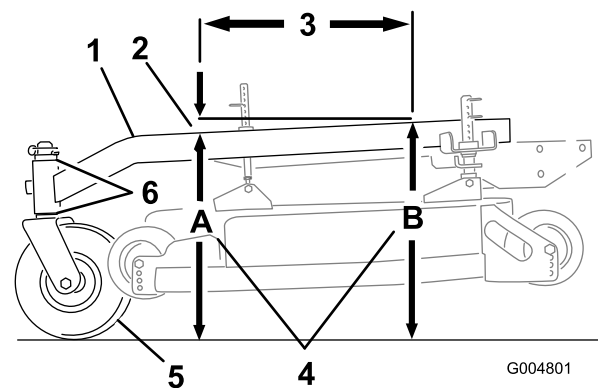

**Figure 57**

- |   |                                |
|---|--------------------------------|
| 1. Carrier Frame  | 4. Height at locations A and B |
| 2. 1/8 inch -3/8 inch (3-10 mm) pitch over 24 inch (61 cm) length | 5. Caster Wheel                |
| 3. 24 inches (61 cm)  | 6. Caster spacers              |

2. Measure carrier frame height at location **A** (Figure 57).
3. Measure carrier frame height at location **B** (Figure 57).

- The height at location **A** must be an 1/8-3/8 inch (3 mm -10 mm) lower than location **B** (Figure 57).
- If the carrier frame is not correct, move caster spacers to make it an 1/8-3/8 inch (3 -10 mm) pitch (Figure 57). Move spacers from top or bottom to make the correct pitch.
- The tire pressure may also be adjusted slightly to make an 1/8-3/8 inch (3 -10 mm) pitch.

## Checking the Carrier Frame Side-to-Side Height

The carrier frame needs to be parallel side-to-side from the ground.

- Disengage the PTO and set the parking brake.
- Stop the engine, remove the key, and wait for all moving parts to stop before leaving the operating position.
- Adjust the tire pressure in the rear tires to specifications; refer to Drive System Maintenance , page 29 .
- Measure carrier frame height at location **A** (Figure 58).
- Measure carrier frame height at location **B** (Figure 58).
- If the carrier frame height is not the same move spacer from top or bottom of caster wheel, to make it level. The tire pressure may also be adjusted slightly to make it level.

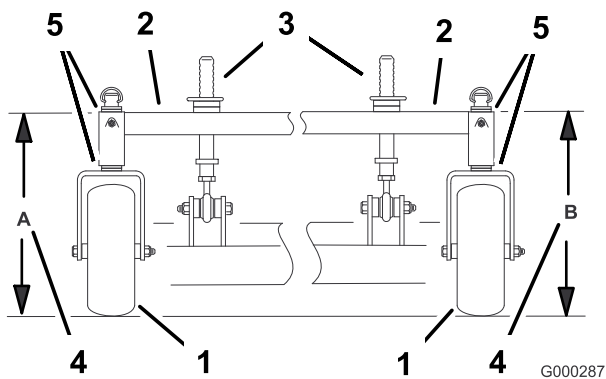

Figure 58

- |                             |                                     |
|-----------------------------|-------------------------------------|
| 1. Caster Wheel             | 4. Same height at locations A and B |
| 2. Carrier Frame            | 5. Caster spacers                   |
| 3. Front height-of-cut pins |                                     |

## Checking the Mower Deck Front-to-Rear Pitch

- Adjust the tire pressure in the rear tires to specifications; refer to Drive System Maintenance , page 29 .
- Position one blade front-to-rear. Measure at **A** and **B** locations from a level surface to the cutting edge of the blade tips (Figure 59).
- The mower blade should be a 1/4 inch (6 mm) lower in front at **A** than in the rear at **B**. Rotate blades and repeat for other blades. If it is not correct, proceed to Changing the Deck Front-to-Rear Pitch.

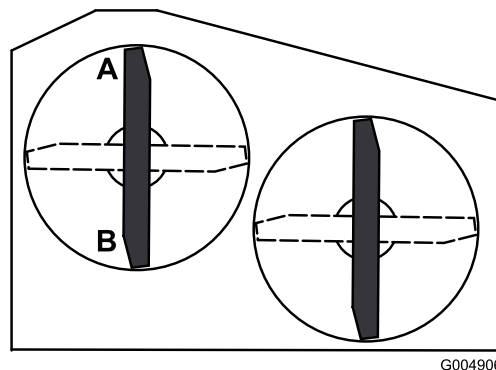
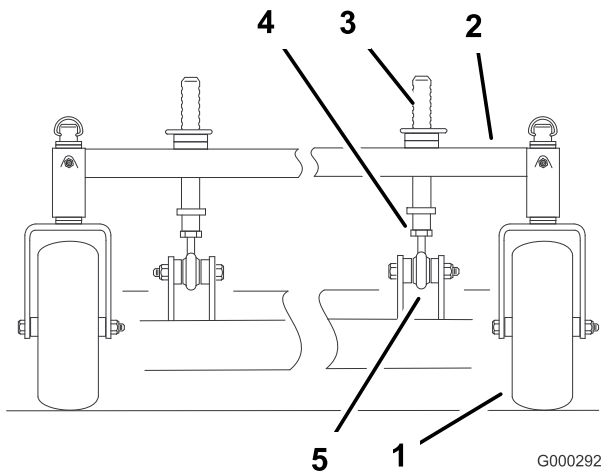

Figure 59

## Changing the Mower Deck Front-to-Rear Pitch

Changing the front-to-rear pitch is done by adjusting the front height-of-cut posts.

- To change the front-to-rear pitch, the front height-of-cut posts can be adjusted (Figure 60).



**Figure 60**

- |                             |               |
|-----------------------------|---------------|
| 1. Caster Wheel             | 4. Jam nut    |
| 2. Carrier Frame            | 5. Ball joint |
| 3. Front height-of-cut pins |               |

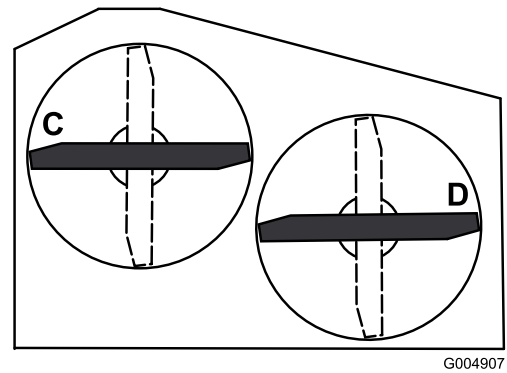

**Figure 61**

- The difference between measurements **C** and **D** should be no more than 1/4 inch (6 mm).

## Changing the Mower Deck Side-to-Side Height

Changing the side-to-side height is done by adjusting the rear tire pressure and caster spacers.

- Change the rear tire pressure. Do this to the corresponding side that needs adjustment.
- Adjust the caster spacer.
- Recheck the front-to-rear pitch and side to side leveling of the cutting unit.

## Matching Height of Cut

- Check the rear tire pressure.
- Set the height-of-cut to the 4 inch (101.6 mm) position following the height-of-cut decal.
- With the machine on level surface, position one blade front-to-rear. Measure at **A** and from level surface to the cutting edge of the blade tips (Figure 62).

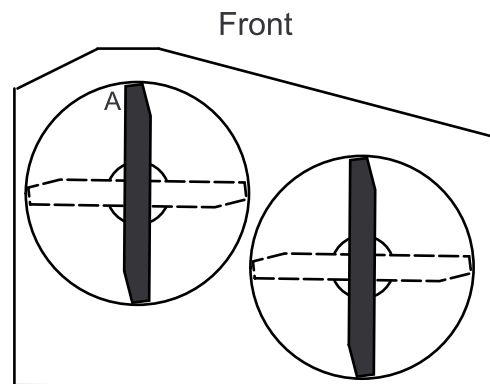

**Figure 62**

- The measurement should be 4 inch (101.6 mm).
- If it does not measure correctly:

- To raise the front of the deck, loosen jam nut and rotate the front pin clockwise (Figure 60).
- To lower the front of the deck, loosen jam nut and rotate the front pin counter clockwise (Figure 60).
- Position the blades front-to-rear. Measure at **C** and **D** locations (Figure 59) from a level surface to the cutting edge of the blades.
- Check the side-to-side leveling of the cutting unit.
- Tighten the jam nuts (Figure 60).

## Checking the Mower Deck Side-to-Side Height

- Adjust the rear tire pressure to specifications; refer to Drive System Maintenance , page 29 .
- Position the blades side-to-side. Measure at **C** and **D** locations from a level surface to the cutting edge of blade tips (Figure 61).

- A. Adjust the rear tire pressure.
  - B. Adjust the caster fork spacers.
  - C. Adjust the front mower deck support pins.
6. Check the carrier frame front-to-rear pitch.

## Replacing the Grass Deflector



An uncovered discharge opening could allow the lawn mower to throw objects in the operator's or bystander's direction and result in serious injury. Also, contact with the blade could occur.

Never operate the lawn mower unless you install a cover plate, a mulch plate, grass deflector or bagger.

1. Remove the locknut, bolt, spring and spacer holding the deflector to the pivot brackets (Figure 63). Remove damaged or worn grass deflector.

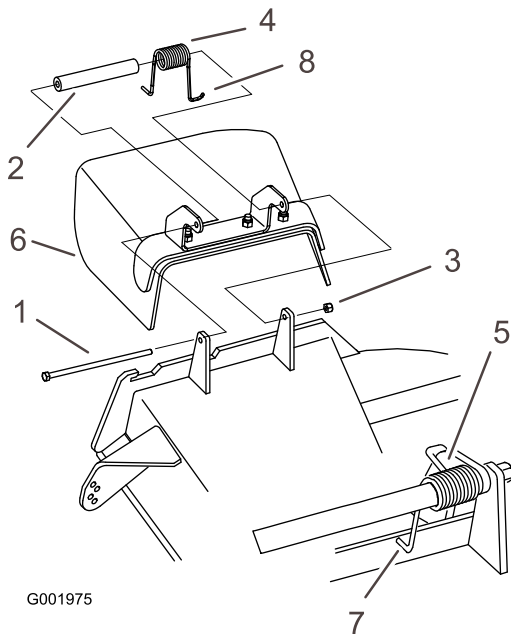

**Figure 63**

- |            |   |
|------------|---|
| 1. Bolt    | 5. Spring installed   |
| 2. Spacer  | 6. Grass Deflector  |
| 3. Locknut | 7. L end of spring, place behind deck edge before installing bolt |
| 4. Spring  | 8. J hook end of spring   |

**Note:** Make sure the **L** end of spring is installed behind deck edge before installing the bolt as shown in Figure 63.

3. Install bolt and nut. Place the **J** hook end of spring around grass deflector (Figure 63).

**Important:** The grass deflector must be able to rotate. Lift the deflector up to the full open position and ensure that it rotates into the full down position.

2. Place spacer and spring onto grass deflector. Place the **L** end of spring behind deck edge.

# Cleaning

## Cleaning Under the Mower

**Service Interval:** Before each use or daily

Remove the grass buildup under the mower daily.

1. Disengage the PTO, move the motion control levers to the neutral locked position and set the parking brake.
2. Stop the engine, remove the key, and wait for all moving parts to stop before leaving the operating position.
3. Raise the front of the machine and use jack stands to support the mower.

## Waste Disposal

Engine oil, batteries, hydraulic oil, and engine coolant are pollutants to the environment. Dispose of these according to your state and local regulations.

# Storage

## Cleaning and Storage

1. Disengage the power take off (PTO), set the parking brake, and turn the ignition key to off. Remove the key.
2. Remove grass clippings, dirt, and grime from the external parts of the entire machine, especially the engine. Clean dirt and chaff from the outside of the engine's cylinder head fins and blower housing.

**Important:** You can wash the machine with mild detergent and water. Do not pressure wash the machine. Avoid excessive use of water, especially near the drive system and engine. Pressure washing can force dirt and water into critical parts, such as spindle bearings and electrical switches.

3. Check the brake; refer to Servicing the Brake in Brake Maintenance , page 32.
  4. Service the air cleaner; refer to Servicing the Air Cleaner in Engine Maintenance , page 24.
  5. Grease the machine; refer to Greasing and Lubrication in Lubrication , page 22.
  6. Change the engine oil; refer to Servicing the Engine in Engine Maintenance , page 24.
  7. Check the tire pressure; refer to Checking the Tire Pressure in Drive System Maintenance , page 29.
  8. For long-term storage:
    - A. Add stabilizer/conditioner additive to fuel in the tank.
    - B. Run engine to distribute conditioned fuel through the fuel system (5 minutes).
    - C. Stop engine, allow to cool and drain the fuel tank; refer to Servicing the Fuel Tank in Fuel System Maintenance , page 27, or operate engine until it stops.
    - D. Restart engine and run until it stops. Repeat, on Choke until engine will not restart.
    - E. Dispose of fuel properly. Recycle as per local codes.
- Note:** Do not store stabilizer/conditioned gasoline over 90 days.
9. Remove the spark plug(s) and check its condition; refer to Servicing the Spark Plug in Engine Maintenance , page 24. With the spark plug(s) removed from the engine, pour two tablespoons of engine oil into the spark plug hole. Now use the starter to crank the engine and distribute the oil

inside the cylinder. Install the spark plug(s). Do not install the wire on the spark plug(s).

10. Check and tighten all bolts, nuts, and screws. Repair or replace any part that is damaged or defective.
11. Paint all scratched or bare metal surfaces. Paint is available from your Authorized Service Dealer.
12. Store the machine in a clean, dry garage or storage area. Remove the key from the ignition switch and keep it in a memorable place. Cover the machine to protect it and keep it clean.

# Troubleshooting

Problem	Possible Cause	Corrective Action
Engine will not start, starts hard, or fails to keep running.	<ol style="list-style-type: none"> <li>1. Fuel tank is empty.</li> <li>2. Choke is not on.</li> <li>3. Air cleaner is dirty.</li> <li>4. Spark plug wire is loose or disconnected.</li> <li>5. Spark plug is pitted, fouled, or the gap is incorrect.</li> <li>6. Dirt in the fuel filter.</li> <li>7. Dirt, water, or stale fuel is in the fuel system.</li> <li>8. The gap between the neutral switch bolt and the switch is not correct.</li> </ol>	<ol style="list-style-type: none"> <li>1. Fill fuel tank with gasoline.</li> <li>2. Move the choke lever to choke position.</li> <li>3. Service the air cleaner element.</li> <li>4. Install wire on spark plug.</li> <li>5. Install a new, correctly gapped spark plug.</li> <li>6. Replace the fuel filter.</li> <li>7. Contact an Authorized Service Dealer.</li> <li>8. Contact an Authorized Service Dealer.</li> </ol>
Engine loses power.	<ol style="list-style-type: none"> <li>1. Engine load is excessive.</li> <li>2. Air cleaner is dirty.</li> <li>3. Oil level in the crankcase is low.</li> <li>4. Cooling fins and air passages under the engine blower housing are plugged.</li> <li>5. Spark plug is pitted, fouled, or the gap is incorrect.</li> <li>6. Vent hole in the fuel cap is plugged.</li> <li>7. Dirt in the fuel filter.</li> <li>8. Dirt, water, or stale fuel is in the fuel system.</li> </ol>	<ol style="list-style-type: none"> <li>1. Reduce the ground speed.</li> <li>2. Service the air cleaner.</li> <li>3. Add oil to the crankcase.</li> <li>4. Remove the obstruction from the cooling fins and air passages.</li> <li>5. Install a new, correctly gapped spark plug.</li> <li>6. Clean or replace the fuel cap.</li> <li>7. Replace the fuel filter.</li> <li>8. Contact an Authorized Service Dealer.</li> </ol>
Engine overheats.	<ol style="list-style-type: none"> <li>1. Engine load is excessive.</li> <li>2. Oil level in the crankcase is low.</li> <li>3. Cooling fins and air passages under the engine blower housing are plugged.</li> </ol>	<ol style="list-style-type: none"> <li>1. Reduce the ground speed.</li> <li>2. Add oil to the crankcase.</li> <li>3. Remove the obstruction from the cooling fins and air passages.</li> </ol>
Machine does not drive.	<ol style="list-style-type: none"> <li>1. Hydraulic oil reservoir low.</li> <li>2. Air in the hydraulic system.</li> <li>3. Pump drive belt slipping.</li> <li>4. Pump drive belt idler spring missing.</li> </ol>	<ol style="list-style-type: none"> <li>1. Add hydraulic oil to the reservoir.</li> <li>2. Bleed the air out the hydraulic system.</li> <li>3. Replace the pump drive belt.</li> <li>4. Replace the pump drive belt idler spring.</li> </ol>
Abnormal vibration.	<ol style="list-style-type: none"> <li>1. Cutting blade(s) is/are bent or unbalanced.</li> <li>2. Blade mounting bolt is loose.</li> <li>3. Engine mounting bolts are loose.</li> <li>4. Loose engine pulley, idler pulley, or blade pulley.</li> <li>5. Engine pulley is damaged.</li> <li>6. Blade spindle is bent.</li> </ol>	<ol style="list-style-type: none"> <li>1. Install new cutting blade(s).</li> <li>2. Tighten the blade mounting bolt.</li> <li>3. Tighten the engine mounting bolts.</li> <li>4. Tighten the appropriate pulley.</li> <li>5. Contact an Authorized Service Dealer.</li> <li>6. Contact an Authorized Service Dealer.</li> </ol>
Uneven cutting height.	<ol style="list-style-type: none"> <li>1. Blade(s) not sharp.</li> <li>2. Cutting blade(s) is/are bent.</li> <li>3. Mower is not level.</li> <li>4. Mower pitch is wrong.</li> <li>5. Underside of mower is dirty.</li> <li>6. Tire pressure is not correct.</li> <li>7. Blade spindle bent.</li> </ol>	<ol style="list-style-type: none"> <li>1. Sharpen the blade(s).</li> <li>2. Install new cutting blade(s).</li> <li>3. Level the mower side-to-side position.</li> <li>4. Adjust the front-to-rear pitch.</li> <li>5. Clean the underside of the mower.</li> <li>6. Adjust the tire pressure.</li> <li>7. Contact an Authorized Service Dealer.</li> </ol>

Problem	Possible Cause	Corrective Action
Blades do not rotate.	<ol style="list-style-type: none"> <li>1. Drive belt is worn, loose or broken.</li> <li>2. Drive belt is off pulley.</li> <li>3. Deck belt is worn, loose or broken.</li> <li>4. Deck belt is off pulley.</li> <li>5. Broken or missing idler spring.</li> <li>6. Electric clutch out of adjustment.</li> <li>7. Clutch connector or wire damaged.</li> <li>8. Damaged electric clutch.</li> <li>9. Safety interlock system prevents blade rotation.</li> <li>10. PTO switch is faulty.</li> </ol>	<ol style="list-style-type: none"> <li>1. Check the belt tension.</li> <li>2. Install drive belt and check adjusting shafts and belt guides for correct position.</li> <li>3. Install new deck belt.</li> <li>4. Install deck pulley and check the idler pulley, idler arm and spring for correct position and function.</li> <li>5. Replace the spring.</li> <li>6. Adjust the clutch air gap.</li> <li>7. Contact an Authorized Service Dealer.</li> <li>8. Contact an Authorized Service Dealer.</li> <li>9. Contact an Authorized Service Dealer.</li> <li>10. Contact an Authorized Service Dealer.</li> </ol>

# Schematics

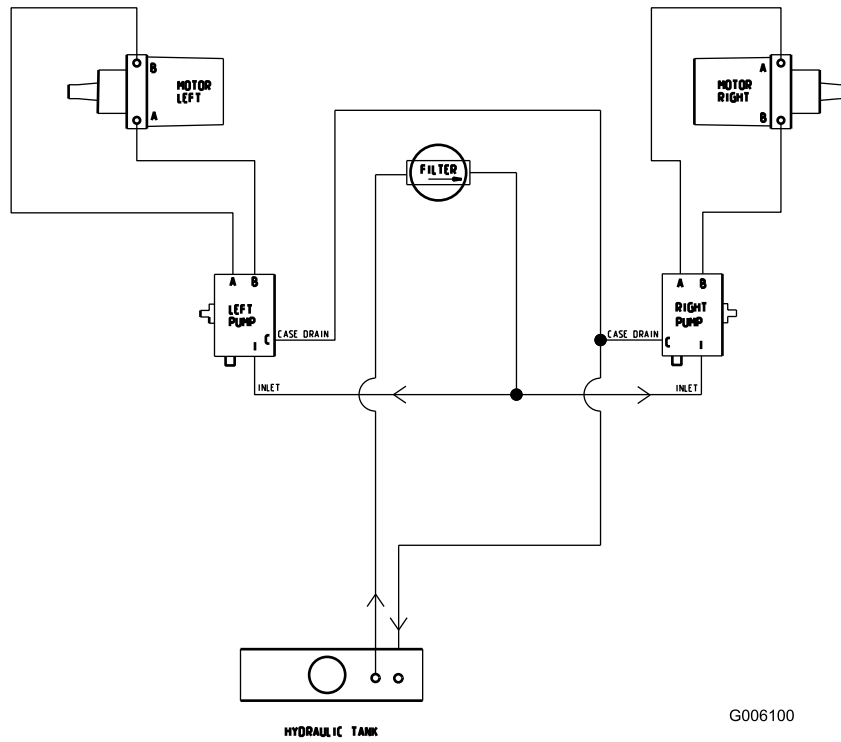

G006100

Hydraulic Schematic (Rev. A)

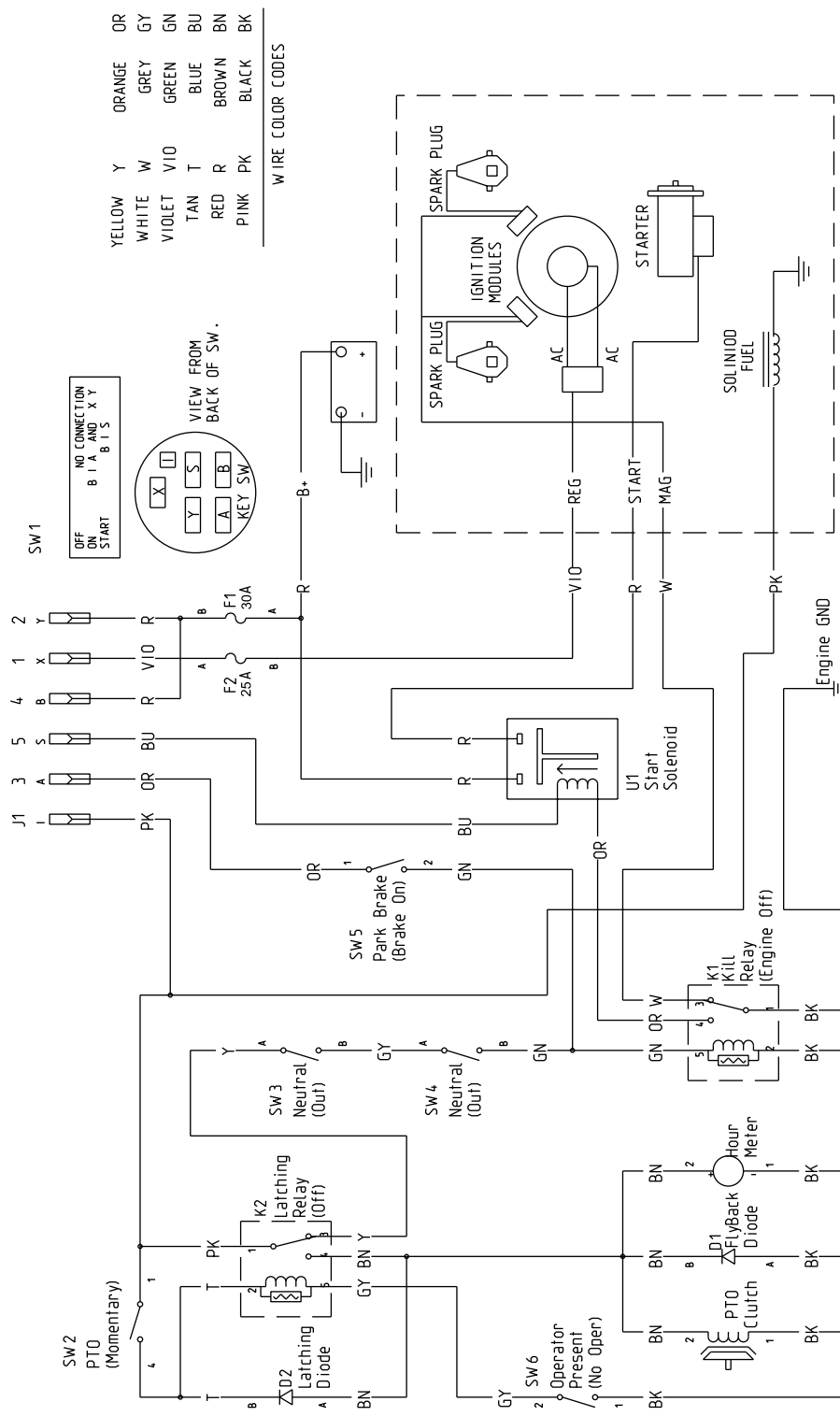

G006101

**Electrical Schematic (Rev. A)**

**Notes:**

**Notes:**



## International Distributor List—Consumer Products

<b>Distributor:</b>	<b>Country:</b>	<b>Phone Number:</b>
Atlantis Su ve Sulama Sisstemleri Lt	Turkey	90 216 344 86 74
Balama Prima Engineering Equip	Hong Kong	852 2155 2163
B-Ray Corporation	Korea	82 32 551 2076
Casco Sales Company	Puerto Rico	787 788 8383
Ceres S.A	Costa Rica	506 239 1138
CSSC Turf Equipment (pvt) Ltd	Sri Lanka	94 11 2746100
Cyril Johnston & Co	Nothern Ireland	44 2890 813 121
Equivier	Mexico	52 55 539 95444
Femco S.A.	Guatemala	502 442 3277
G.Y.K. Company Ltd.	Japan	81 726 325 861
Geomechaniki of Athens	Greece	30 10 935 0054
Guandong Golden Star	China	86 20 876 51338
Hako Gorund and Garden	Sweden	46 35 10 0000
Hydroturf Int. Co	Dubai United Arab Emirates	97 14 347 9479
Hydroturf Egypt LLC	Egypt	202 519 4308
Ibea S.p.A.	Italy	39 0331 853611
Irriamc	Portugal	351 21 238 8260
Jean Heybroek b.v.	Netherlands	31 30 639 4611
Lely (U.K. ) Limited	United Kingdom	44 1480 226 800
Maquiver S.A.	Columbia	57 1 236 4079
Maruyama Mfg. Co. Inc.	Japan	81 3 3252 2285
Metra Kft	Hungary	36 1 326 3880
Mountfield a.s.	Czech Republic	420 255 704 220
Munditol S.A.	Argentina	54 11 4 821 9999
Oslinger Turf Equipment SA	Ecuador	593 4 239 6970
Oy Hako Ground and Garden Ab	Finland	358 987 00733
Parkland Products Ltd	New Zealand	64 3 34 93760
Prochaska & Cie	Austria	43 1 278 5100
RT Cohen 2004 Ltd	Israel	972 986 17979
Riversa	Spain	34 9 52 83 7500
Roth Motorgerate GmBh & Co	Germany	49 7144 2050
Sc Svend Carlsen A/S	Denmark	45 66 109 200
Solvert S.A.S	France	33 1 30 81 77 00
Spypros Stavrinides Limited	Cyprus	357 22 434131
Surge Systems India Limited	India	91 1 292299901
T-Markt Logistics Ltd	Hungary	36 26 525 500
Toro Australia	Australia	61 3 9580 7355
Toro Europe BVBA	Belgium	32 14 562 960



## The Toro Warranty

### Conditions and Products Covered

The Toro® Company and its affiliate, Toro Warranty Company, pursuant to an agreement between them, jointly promises to the original purchaser\* to repair any Toro Product used for normal residential purposes\* if defective in materials or workmanship. The following time periods apply from the date of original purchase:

<b>Products</b>	<b>Warranty Period</b>
Walk Power Mowers	2-year limited warranty
Rear Engine Riders	2-year limited warranty
Lawn & Garden Tractors	2-year limited warranty
Electric Hand Held Products	2-year limited warranty
Snowthrowers	2-year limited warranty
Consumer Zero Turn	2-year limited warranty

\* "Original purchaser" means use the person who originally purchased Toro products.

\* "Normal residential purposes" means use of the product on the same lot as your home. Use at more than one location is considered commercial use, and the commercial use warranty would apply.

### Limited Warranty for Commercial Use

Toro Consumer Products and attachments used for commercial, institutional, or rental use are warranted against defects in materials or workmanship for the following time periods from the date of original purchase:

<b>Products</b>	<b>Warranty Period</b>
Walk Power Mowers	90 day warranty
Rear Engine Riders	90 day warranty
Lawn & Garden Tractors	90 day warranty
Electric Hand Held Products	90 day warranty
Snowthrowers	90 day warranty
Consumer Zero Turn	45 day warranty

### Instructions for Obtaining Warranty Service

If you think that your Toro Product contains a defect in materials or workmanship, follow this procedure:

1. Contact your seller to arrange service of the product. If for any reason it is impossible for you to contact your seller, you may contact any Toro Authorized Distributor to arrange service.
2. Bring the product and your proof of purchase (sales receipt) to your seller or the Service Dealer.

If for any reason you are dissatisfied with the Service Dealer's analysis or with the assistance provided, contact the Toro importer or contact us at:

Customer Care Department, Consumer Division  
Toro Warranty Company  
8111 Lyndale Avenue South  
Bloomington, MN 55420-1196  
Manager: Technical Product Support: 001-952-887-8248

See attached Distributor List

### Owner Responsibilities

You must maintain your Toro Product by following the maintenance procedures described in the operator's manual. Such routine maintenance, whether performed by a dealer or by you, is at your expense.

### Items and Conditions Not Covered

This express warranty does not cover:

- Cost of regular maintenance service or parts, such as filters, fuel, lubricants, tune-up parts, blade sharpening, brake and clutch adjustments.
- Any product or part which has been altered or misused or required replacement or repair due to normal wear, accidents, or lack of proper maintenance.
- Repairs necessary due to improper fuel, contaminants in the fuel system, or failure to properly prepare the fuel system prior to any period of non-use over three months.
- Engine and transmission. These are covered by the appropriate manufacturer's guarantees with separate terms and conditions.

All repairs covered by this warranty must be performed by an Authorized Toro Service Dealer using Toro approved replacement parts.

### General Conditions

The purchaser is covered by the national laws of each country. The rights to which the purchaser is entitled with the support of these laws are not restricted by this warranty.