



Groundsmaster[®] 3500-D

Model No. 30821 - 200000001 and up.

Parts Catalog

Ordering Replacement Parts

To order replacement parts, please supply the part number, the quantity, and the description of each part desired.

Understanding Reference Numbers

Each identified part in an illustration has a reference number. The reference number for a part also appears in the parts list, along with other information about the part.

This catalog uses two special reference number formats, one to indicate parts in a service assembly and another to indicate the quantity of a given part in an illustration.

Service Assembly Reference Numbers

Parts in service assemblies have reference numbers in the form a:b. The a represents the reference number of the entire service assembly and the b represents a sequential number unique to each part within the service assembly.

For example, a wheel assembly might be identified by reference number 6, the tire by 6:1, the valve by 6:2, and the wheel by 6:3. When you order the assembly identified by reference number 6, you receive all parts identified by reference numbers 6:1, 6:2, and 6:3. However, you may also order any part individually. Reference numbers of this type appear in illustrations and in part lists.

Reference Numbers Indicating Quantity

In an illustration, if a reference number indicates more than one part, the reference number has the form nX y. The n represents the quantity of the part, the X is the multiplication symbol, and the y represents the reference number.

For example, in an illustration, the reference number 2X 37 means that two of the parts identified by reference number 37 are indicated.

Contents

Description	Page	Description	Page
Frame And Platform Assembly 4	Reel Motor Assembly 38
Front Wheel And Brake Assembly 5	Battery Assembly 39
Hydraulic Wheel Motor Assembly No. 75-9990 6	Parking Brake Assembly 40
Hydraulic Motor Assembly No. 95-8693 7	Crankcase Assembly 41
Brake Assembly No. 71-1500 8	Oil Pan Assembly 42
Steering Column Assembly 9	Cylinder Head Assembly 43
Steering Control Assembly No. 104-0474 10	Grease And Oil Filter Assembly 44
Rear Fork And Tire Assembly 11	Filter, Oil Cooler, And Pipe Assembly 45
Hydraulic Cylinder Assembly No. 94-8141 12	Head Cover Assembly 46
Hydraulic Motor Assembly No. 95-8694 13	Dipstick Assembly 47
Control Panel Assembly 14	Main Bearing Case Assembly 48
Front Platform Assembly 15	Camshaft Assembly 49
Traction Pedal Assembly 16	Piston And Crankshaft Assembly 50
Control Valve Installation Assembly 17	Flywheel Assembly 51
Control Valve Assembly No. 95-8581 18	Fuel Camshaft Assembly 52
Rear Lifter Assembly 19	Engine Stop Lever Assembly 53
Hydraulic Cylinder Assembly No. 95-8978 21	Stop Solenoid And Fuel Pump Assembly 54
Neutral Arm Assembly 22	Injection Pump Installation Assembly 55
Engine Assembly 23	Injection Pump Assembly No. 98-9643 56
Air Cleaner And Muffler Assembly 24	Governor Assembly 57
Radiator Assembly 25	Speed Control Plate Assembly 58
Hood-Screen Assembly 26	Nozzle Holder And Glow Plug Assembly 59
Fuel System Assembly 27	Nozzle Holder Assembly No. 98-9468 60
Water / Fuel Filter Assembly No. 98-9305 28	Alternator And Pulley Assembly 61
Manifold Block Installation Assembly 29	Alternator Assembly No. 98-9474 62
Manifold Block Assembly No. 100-4826 30	Starter Mount Assembly 63
Hydraulic Tank Assembly 31	Starter Assembly No. 98-9705 64
Hydrostat Assembly 32	Water Flange And Thermostat Assembly 65
Piston Pump Assembly No. 104-0428 34	Water Pump Assembly 66
Carrier Assembly 35	Valve And Rocker Arm Assembly 67
Scissor Assembly 37	Exhaust Manifold And Gasket Assembly 68
		Turbo Charge Assembly 69

Part Description Abbreviations

Part descriptions in this catalog may include the following abbreviations.

AR.	as required	HYD.	hydraulic
ASM.	assembly	LH.	left hand
BBC.	blade brake clutch	NI.	nylon insert
CARR.	carriage	NPTF.	national pipe thread fine
DEG.	degrees	PFH.	phillips flat head
EXT.	external	PPH.	phillips pan head
FH.	flat head	PPHTF.	phillips pan head thread forming
GA.	gauge	PRH.	phillips round head
HD.	heavy-duty	PTH.	phillips truss head
HF.	hex flange	PTO.	power-take-off
HH.	hex head	RH.	right hand
HHF.	hex head flange	ROPS.	roll-over protection system
HHFTF.	hex head flange thread forming	SFH.	slotted fillister head
HJ.	hex jam	SHH.	slotted hex head
HLH.	hex lag head	SHWH.	slotted hex washer head
HOC.	height-of-cut	SPH.	slotted pan head
HSBH.	hex socket button head	SQH.	square head
HSFH.	hex socket flat head	SRH.	slotted round head
HSH.	hex socket head	STD.	standard
HWH.	hex washer head	TAP.	self tapping
HWHTF.	hex washer head thread forming	TTH.	torx truss head

Footnotes

❶ Not serviced separately

❷ * Not Illustrated

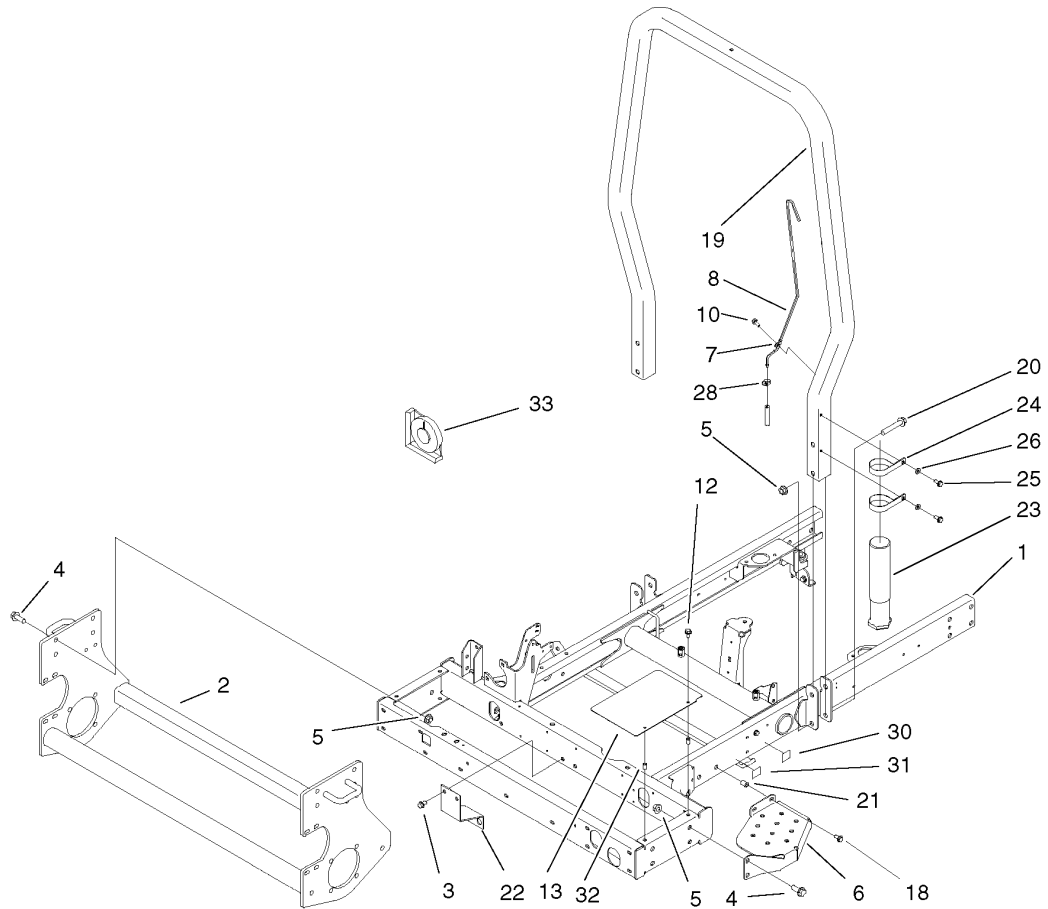

Frame And Platform Assembly

Ref	Part No.	Qty.	Description
1	99-3610-03	1	Frame
2	95-8568-03	1	Frame-Lower
3	3274-80	2	Screw-HH
4	3234-38	8	Screw-Hfh
5	32128-49	12	Nut-HHF
6	99-3375-03	1	Step
7	2412-72	3	Clip-Closed, Insulated
8	95-8615	1	Tube-Breather
10	32144-10	8	Screw-HWH
12	3234-13	2	Screw-HHF
13	104-0468-01	1	Cover-Frame
18	3234-5	2	Screw-HHF
19	99-3350-03	1	Tube-ROPS
20	3234-40	4	Screw-Hfh
21	32148-8	2	Insert-Threaded
22	95-8598-03	1	Bracket-Bulkhead, Scissor
23	74-0720	1	Tube-Manual
24	2412-133	2	R-Clamp
25	32144-70	2	Screw-HH
26	3256-23	2	Washer-Flat
28	2412-108	1	Clamp-Worm
30	63-9920	1	Decal-Level, Noise
31	85-6930	1	Decal-Noise Rating
32	32148-6	2	Nut-Insert

Ref	Part No.	Qty.	Description
33	99-3503	1	Indicator-Angle

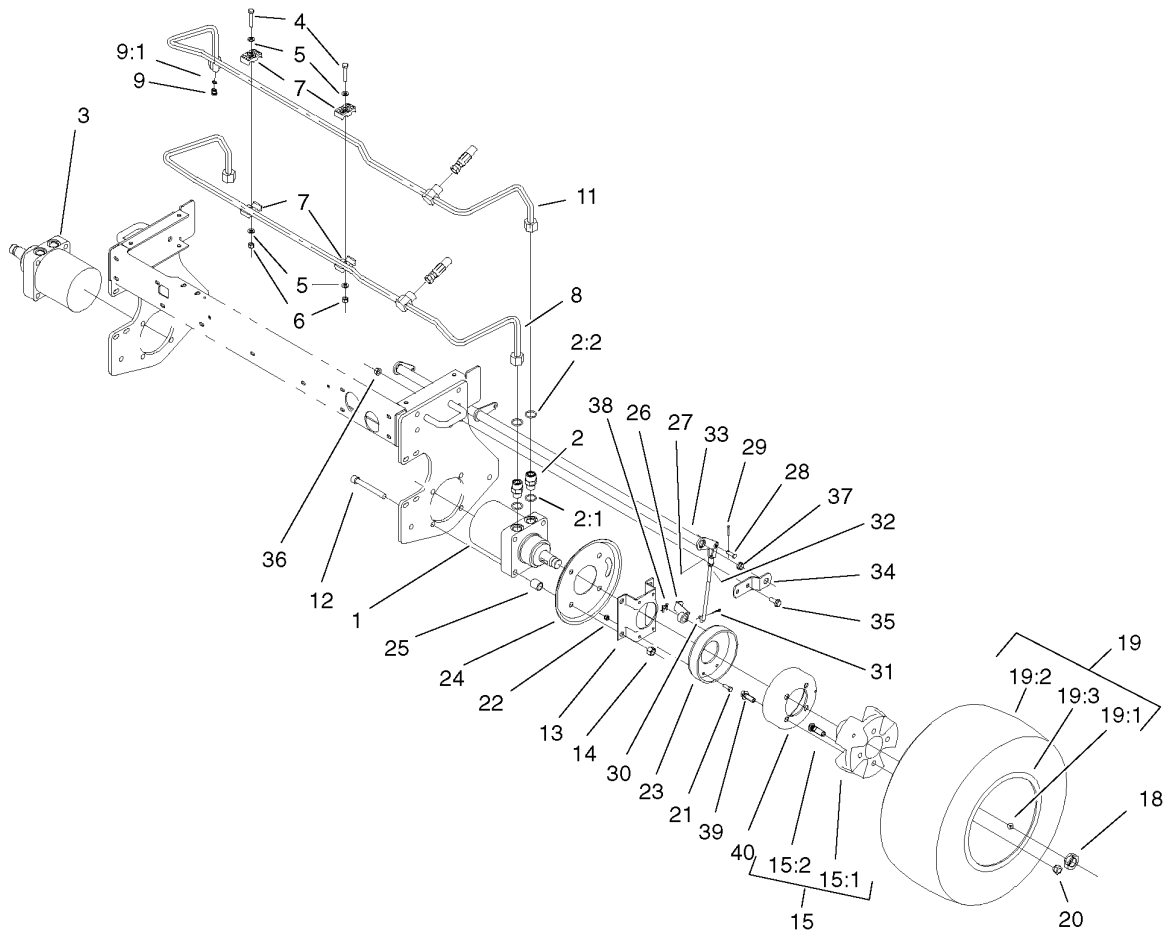

Front Wheel And Brake Assembly

Ref	Part No.	Qty.	Description
1	75-9990	1	Hydraulic Motor ASM
2	340-7	4	Adapter
2:1	237-65	1	O-Ring
2:2	237-80	1	O-Ring
3	95-8693	1	Hydraulic Motor ASM
4	322-9	2	Screw-HH
5	3256-23	4	Washer-Flat
6	3296-29	2	Nut-Lock
7	56-7971	4	Clamp-Tube
8	95-8783	1	Tube ASM
9	353-990	1	Plug
9:1	237-78	1	O-Ring
11	95-8784	1	Tube ASM
12	3274-99	8	Screw-HSH
13	84-2000-03	2	Bracket-Brake
14	3296-23	8	Nut-Lock, NI
15		2	Wheel Hub/Stud ASM
15:1	104-0462-03	1	Hub-Wheel
15:2	10-6830	4	Stud-Type, Drive
18	26-3790	2	Nut-Lock
19		2	Tire & Wheel ASM
19:1	232-27	1	Stem-Valve
19:2	104-0451	1	Tire
19:3	104-0452	1	Rim-Wheel

Ref	Part No.	Qty.	Description
20	242-50	8	Nut-Lug
21	321-5	8	Screw-HH
22	3296-42	8	Nut-Lock
23	71-1500	2	Brake ASM
24	104-0485-03	2	Shield-Wheel
25	92-1715	8	Spacer
26	93-6850	2	Lever-Brake
27	282-2	2	Yoke
28	283-1	2	Pin-Yoke
29	3272-10	2	Pin-Cotter
30	104-4627	2	Rod-Adjusting
31	3272-6	2	Pin-Cotter
32	3220-2	2	Nut-HJ
33	104-4625-03	1	Brake Pivot Shaft ASM
34	95-8683	2	Bracket-Pivot, Brake
35	3234-11	4	Screw-HHF
36	32128-43	4	Nut-Flange
37	256-156	2	Bushing-Flange
38	70-9850	2	Clip-Retaining
39	3274-105	8	Screw-HSBH
40	104-4809	2	Drum-Brake

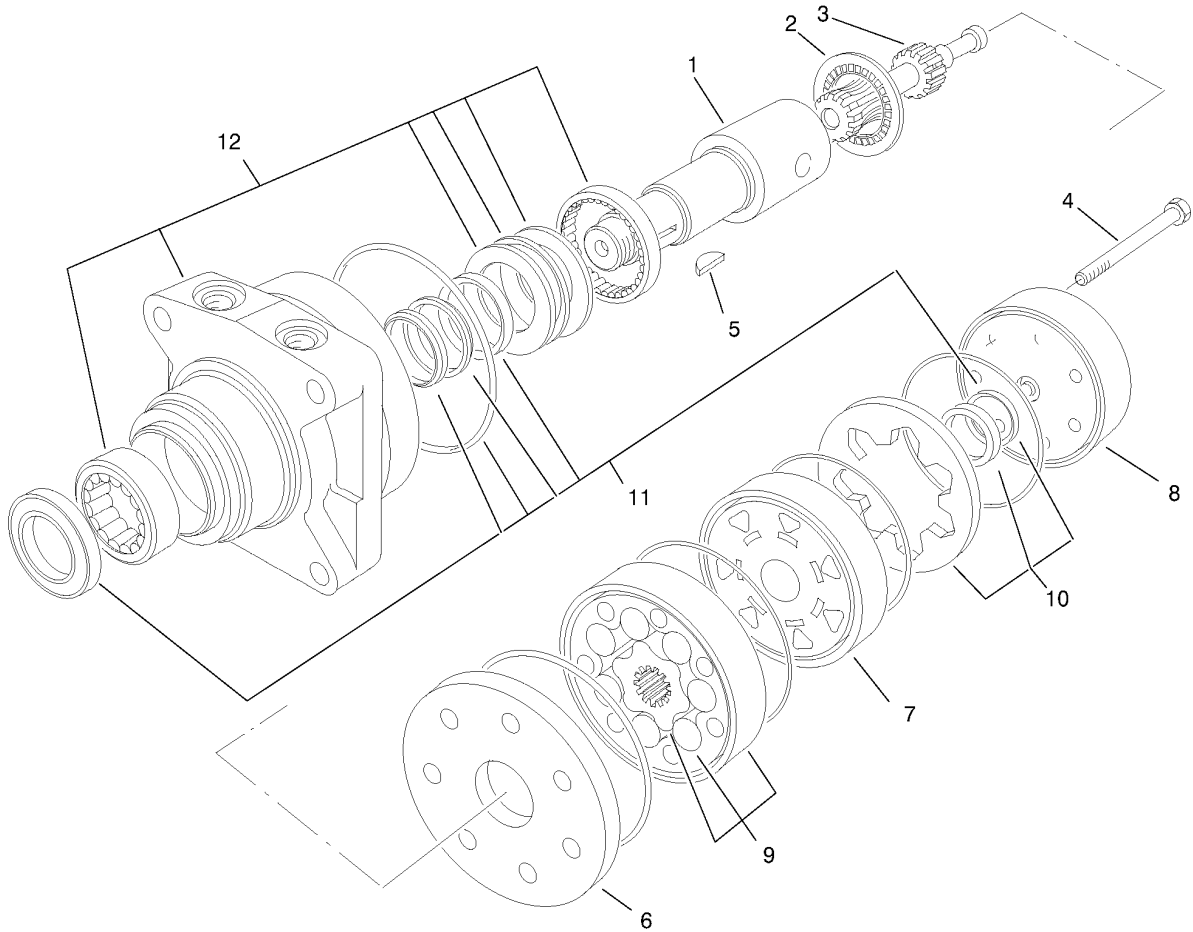

Hydraulic Motor Assembly No. 95-8693

Ref	Part No.	Qty.	Description
1	76-0860	1	Shaft-Coupling
2	76-0850	1	Bearing-Thrust
3	76-0960	1	Link-Drive
4	76-1010	7	Screw
5	3257-42	1	Key-Woodruff
6	76-0870	1	Plate-Wear
7	99-3535	1	Manifold
8	76-0940	1	End Cover ASM
9	76-0970	1	Set-Rotor
10	76-0880	1	Commutator ASM
11	76-0800	1	Kit-Seal
12	76-0810	1	Wheel Motor Housing ASM

--	--	--	--

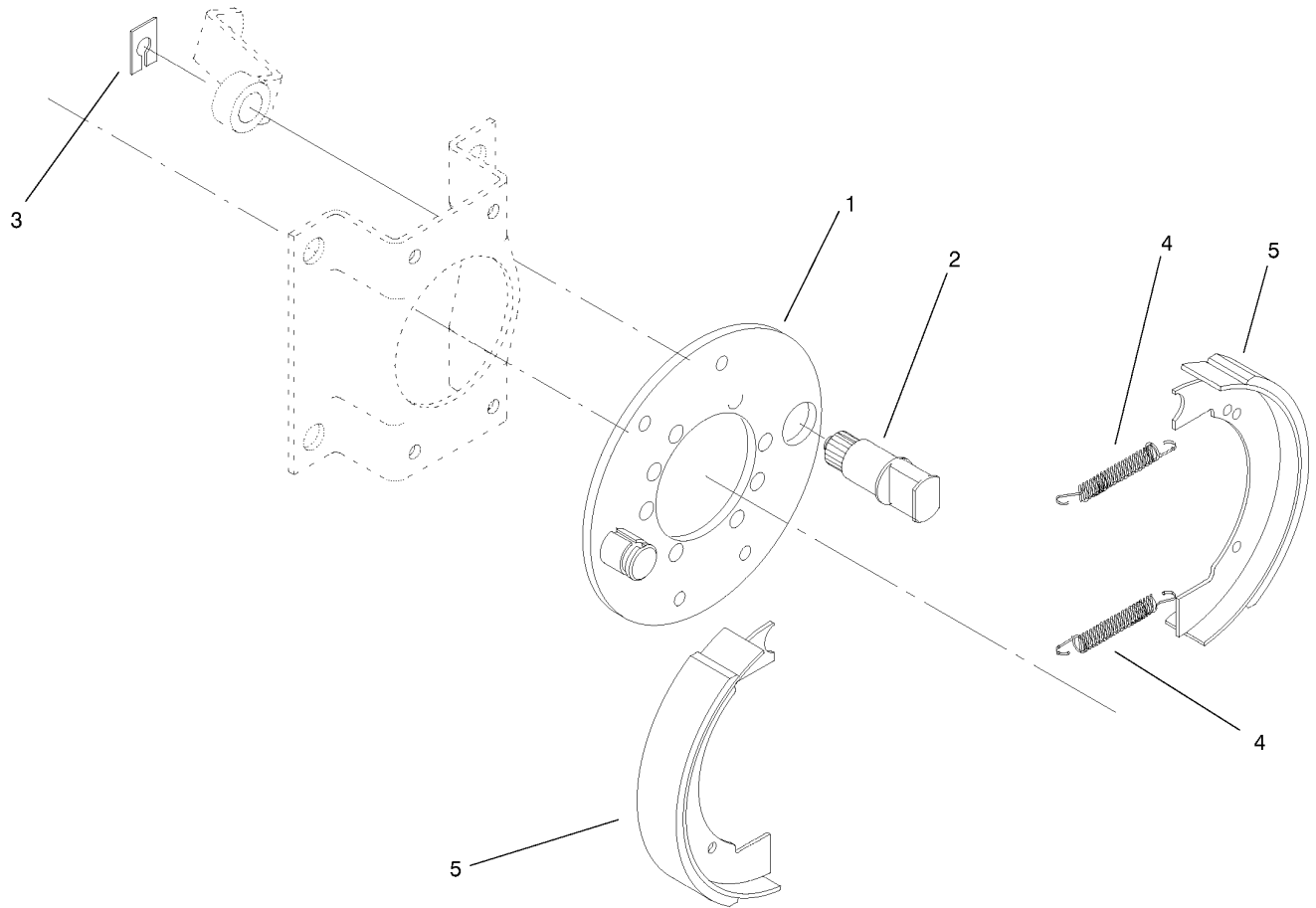

Brake Assembly No. 71-1500

Ref	Part No.	Qty.	Description
1	70-9870	1	Plate-Backing
2	70-9860	1	Cam-Brake
3	70-9850	1	Clip-Retaining
4	70-9880	2	Spring-Return
5	70-9840	2	Shoe-Brake

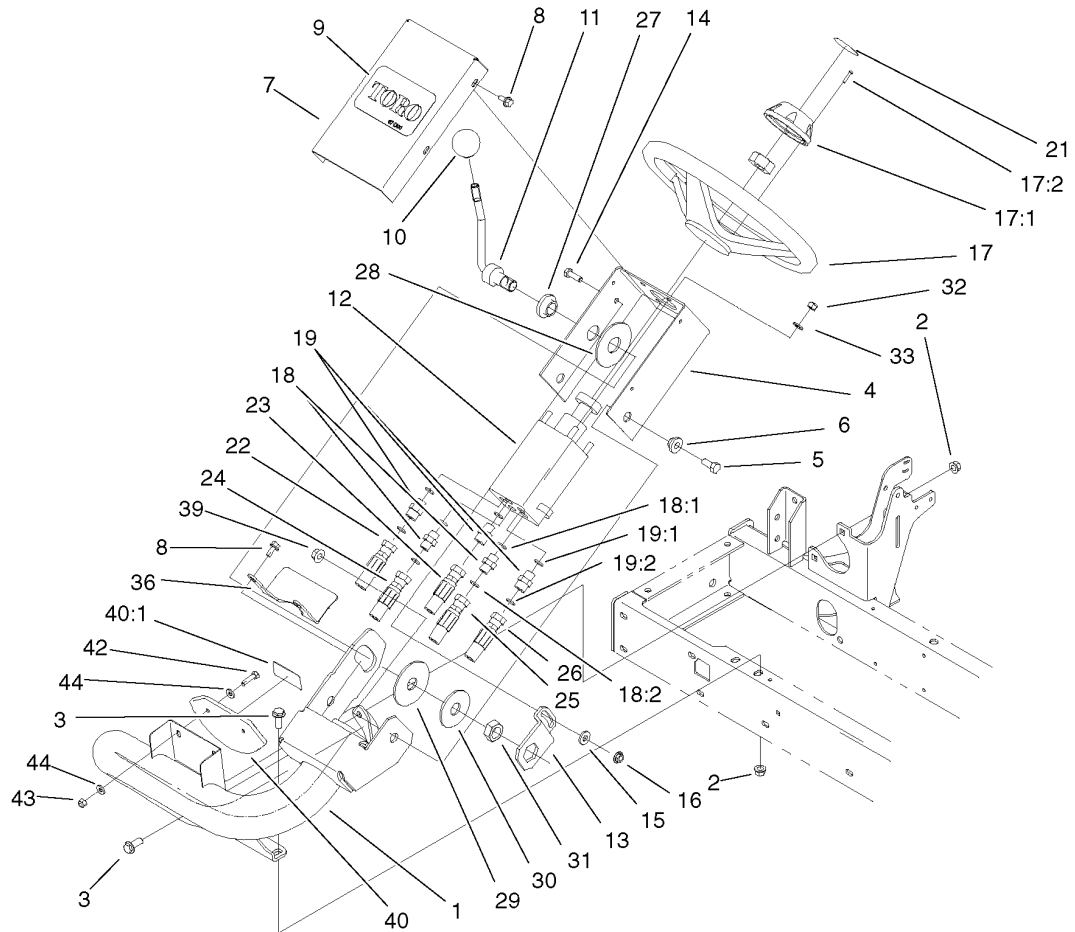

Steering Column Assembly

Ref	Part No.	Qty.	Description
1	100-4896-01	1	Arm-Steering
2	32128-43	4	Nut-Flange
3	3234-11	4	Screw-HHF
4	95-8793-01	1	Bracket-Valve, Steering
5	323-5	2	Screw-HH
6	93-5988	2	Hub-Pivot
7	95-8794-01	1	Cover-Valve, Steering
8	32144-10	5	Screw-HWH
9	67-1300	1	Decal-Toro
10	233-48	1	Knob
11	95-8798-03	1	Lever-Steering
12	104-0474	1	Control-Steering
13	80-2880	1	Bracket-Tilt
14	322-5	1	Screw-HH
15	3256-3	1	Washer-Flat
16	32128-44	1	Nut
17	68-5130	1	Wheel-Steering
17:1	68-5140	1	Cap-Wheel, Steering
17:2	32144-21	1	Screw
18	340-1	2	Adapter
18:1	237-35	1	O-Ring
18:2	237-42	1	O-Ring
19	340-2	3	Adapter
19:1	237-22	1	O-Ring

Ref	Part No.	Qty.	Description
19:2	237-42	1	O-Ring
21	68-5370	1	Decal-Toro
22	95-8842	1	Hose ASM
23	95-8843	1	Hose ASM
24	100-4892	1	Hose ASM
25	100-4893	1	Hose ASM
26	95-8846	1	Hose ASM
27	99-3502	1	Boss
28	31-0390	1	Disc-Friction
29	82-9010	1	Disc-Friction
30	80-2930	1	Washer-Flat
31	3218-7	1	Nut-Jam
32	3296-4	4	Nut-Lock, NI
33	3256-23	4	Washer-Flat
36	99-3405-01	1	Shield-Steering
39	32128-21	2	Nut-HF
40	100-4929	1	Slope Indicator ASM
40:1	100-4933	1	Decal-Danger
40:1	100-4837	1	Decal-Danger
42	321-6	2	Screw-HH
43	3296-42	2	Nut-Lock
44	3256-22	4	Washer-Flat

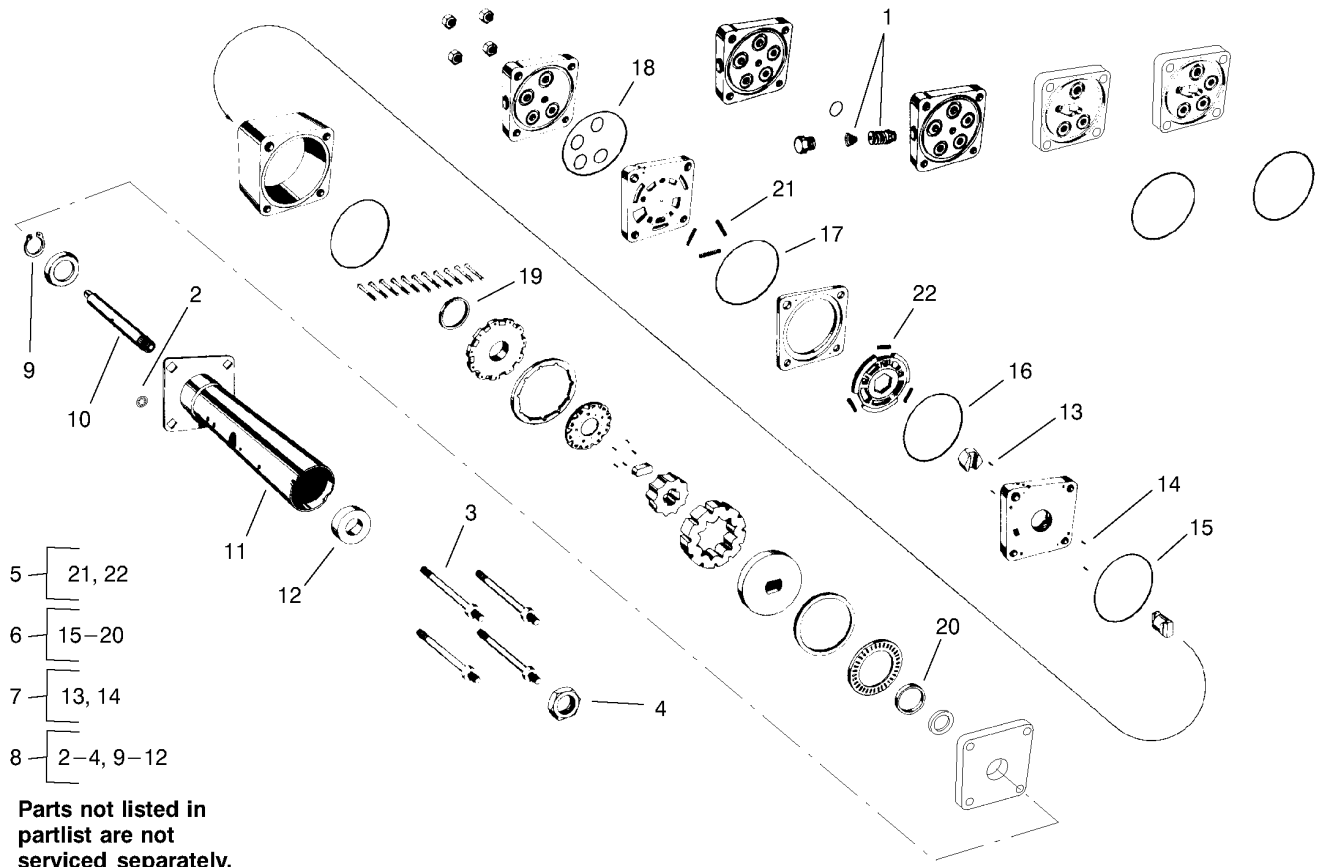

- 5 — 21, 22
- 6 — 15-20
- 7 — 13, 14
- 8 — 2-4, 9-12

Parts not listed in partlist are not serviced separately.

Steering Control Assembly No. 104-0474

Ref	Part No.	Qty.	Description
1	99-3523	1	Cartridge-Valve, Relief
2	92-7316	4	Nut-On, Push
3	99-3524	4	Bolt-Special
4	47-6990	1	Nut
5	66-9970	1	Kit-Spring
6	66-9980	1	Kit-Seal
7	66-9990	1	Kit-Roller, Needle
8	104-0475	1	Column ASM

--	--	--	--

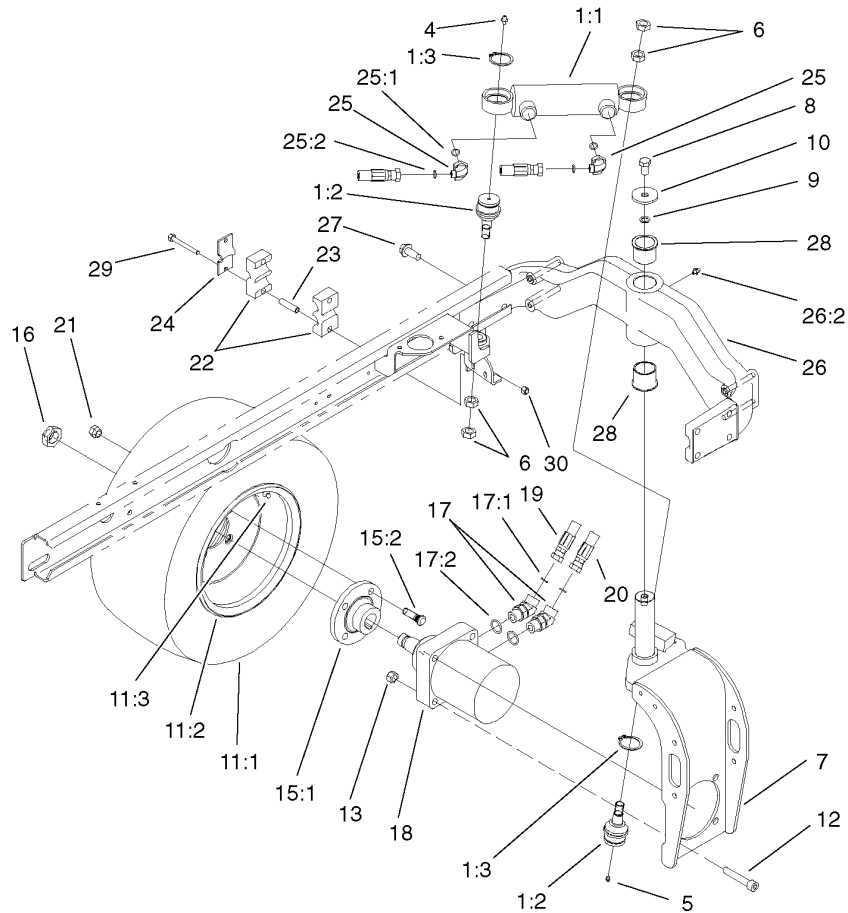

Rear Fork And Tire Assembly

Ref	Part No.	Qty.	Description
1		1	Steering Cylinder/Balljoint ASM
1:1	94-8141	1	Hydraulic Cylinder ASM
1:2	92-5838	2	Joint-Ball
1:3	32151-104	2	Ring-Retaining, External
4	302-5	1	Fitting-Grease
5	302-59	1	Plug-Threaded
6	3220-6	4	Nut-Jam
7	95-8905-01	1	Fork-Rear
8	325-3	1	Screw-HH
9	3255-2	1	Washer-Lock/EXT
10	75-7730	1	Washer-Thrust
11		1	Tire & Wheel ASM
11:1	95-8656	1	Tire
11:2	95-8657	1	Rim-Wheel
11:3	232-27	1	Stem-Valve
12	3274-93	4	Screw-HSH
13	3296-23	4	Nut-Lock, NI
15		1	Wheel Hub / Stud ASM
15:1	10-6870-03	1	Hub-Wheel
15:2	10-6830	4	Stud-Type, Drive
16	26-3790	1	Nut-Lock
17	340-14	2	Fitting-HYD., 45Ø
17:1	237-65	1	O-Ring
17:2	237-80	1	O-Ring

Ref	Part No.	Qty.	Description
18	95-8694	1	Hydraulic Motor ASM
19	100-4878	1	Hose ASM
20	100-4877	1	Hose ASM
21	242-50	4	Nut-Lug
22	82-8170	2	Clamp
23	93-7960	2	Spacer
24	93-7961	1	Clamp-Drain, Case
25	340-132	2	Elbow-90Ø
25:1	237-78	1	O-Ring
25:2	237-21	1	O-Ring
26	18-3979-03	1	Rear Casting ASM
26:2	302-5	1	Fitting-Grease
27	3234-38	8	Screw-Hfh
28	95-8805	2	Bushing
29	322-13	2	Screw-HH
30	3296-29	2	Nut-Lock

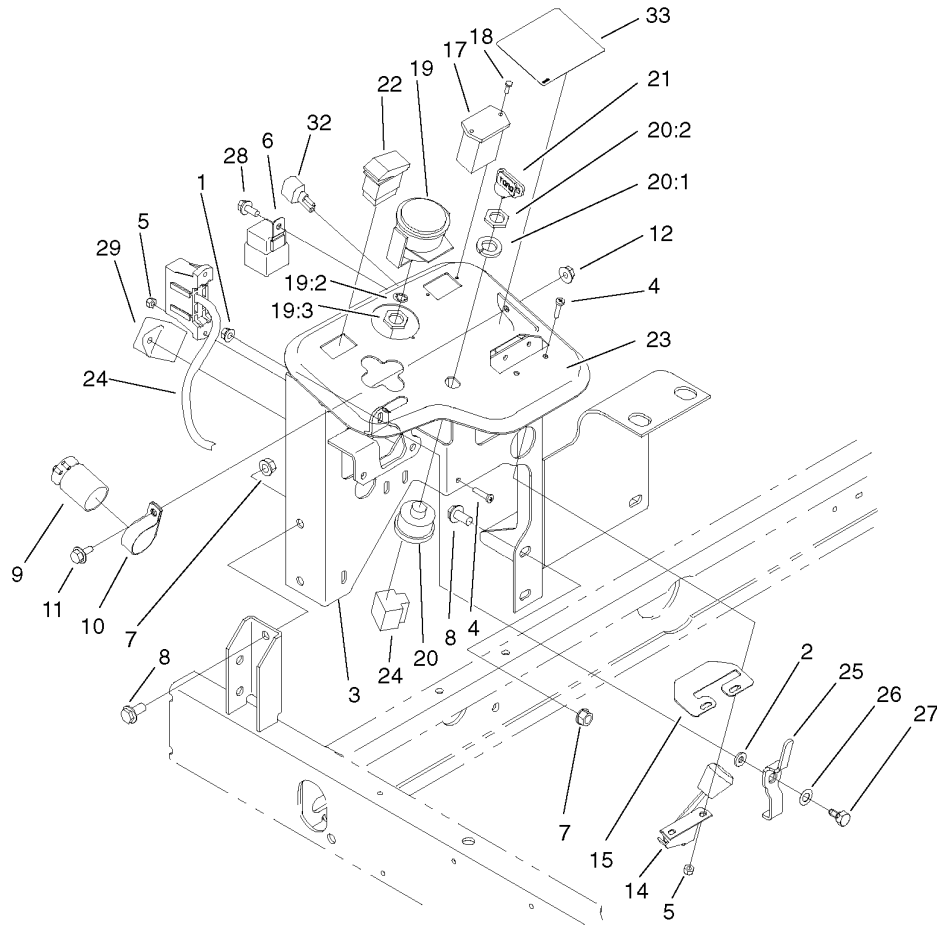

Control Panel Assembly

Ref	Part No.	Qty.	Description
1	32128-32	1	Nut-HHF
2	3256-22	1	Washer-Flat
3	95-8712-03	1	Panel-Control
4	3250-27	4	Screw-PPH
5	3296-2	4	Nut-Lock
6	70-1480	4	Relay
7	32128-43	5	Nut-Flange
8	3234-1	5	Screw-HHF
9	37-2690	1	Capacitor
10	2412-74	1	Clamp
11	3234-4	1	Screw-HHF
12	32128-33	1	Nut-HF
14	95-8855	1	Control-Throttle
15	104-0421	1	Plate-Stop, Throttle
17	75-6820	1	Hourmeter
18	32144-18	2	Screw-HH
19	93-7053	1	Cluster-Lamp, Warning
e*19:1	219-17	4	Bulb
19:2	3254-1	1	Washer-Lock/Int
19:3	3217-26	1	Nut-Hex
20	88-9830	1	Switch-Ignition
20:1	3254-5	1	Washer-Lock/Internal
20:2	218-461	1	Nut-HH
21	63-8360	2	Key-Ignition

Ref	Part No.	Qty.	Description
22	95-8999	1	Switch
23	100-4834	1	Decal-Console
24	100-4823	1	Harness-Wire
25	99-3401-03	1	Lever-Valve, Lock
26	3290-477	1	Washer-Curved
27	63-3410	1	Screw-Shoulder
28	32144-10	5	Screw-HWH
29	99-3463	1	Controller-Glow
32	100-4918	4	Diode
33	99-3558	1	Decal-Console, Ce

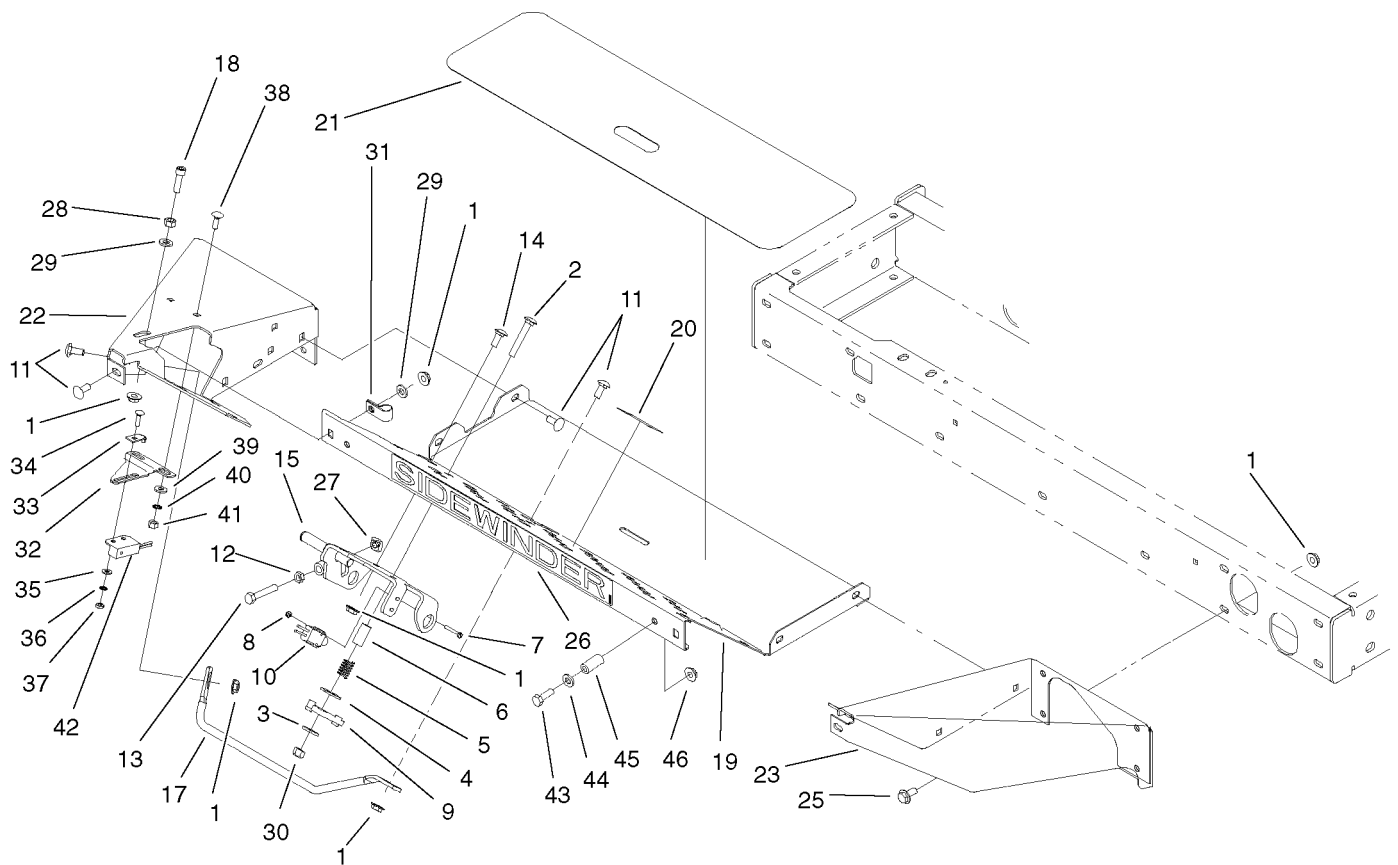

Front Platform Assembly

Ref	Part No.	Qty.	Description
1	32128-44	22	Nut
2	3230-6	1	Screw-CARR
3	3256-3	1	Washer-Flat
4	3256-40	1	Washer-Flat
5	65-9940	1	Spring
6	95-8866	1	Tube-Arm, Rocker
7	32105-9	2	Screw
8	3296-9	2	Nut-Lock NI
9	99-3593	1	Arm-Rocker
10	95-8900	1	Switch
11	3230-1	9	Screw-CARR
12	3218-2	1	Nut-Jam
13	322-41	1	Screw-HH
14	3230-23	2	Screw-CARR
15	95-8869-03	1	Bracket-Pedal, Traction
17	95-8893	1	Bar-Deflector
18	3274-22	1	Screw-HSH
19	95-8610-01	1	Plate-Floor
20	99-3444	1	Decal-Mow/Transport
21	99-3478	1	Tread-Foot
22	100-4884-01	1	Support-Floor, RH
23	95-8612-01	1	Bracket-Floor Plate, LH
25	3234-5	10	Screw-HHF
26	99-3388	1	Decal-Sidewinder

Ref	Part No.	Qty.	Description
27	99-3565	1	Nut-Square
28	3217-6	1	Nut-Hex
29	3256-23	2	Washer-Flat
30	3296-29	1	Nut-Lock
31	2412-103	1	Clamp
32	100-4871	1	Bracket-Switch, Neutral
33	100-4872	1	Plate-Switch, Neutral
34	3229-20	1	Screw-CARR
35	3256-14	1	Washer-Flat
36	3255-17	1	Washer-Lock/EXT
37	3296-2	1	Nut-Lock
38	3229-1	2	Screw-CARR
39	3256-22	2	Washer-Flat
40	3255-7	2	Washer-Lock/EXT
41	3217-5	2	Nut-Hex
42	100-1270	1	Switch-Proximity
43	323-9	2	Screw-HH
44	3256-4	2	Washer-Flat
45	104-4613	2	Tube-Latch
46	32128-43	2	Nut-Flange

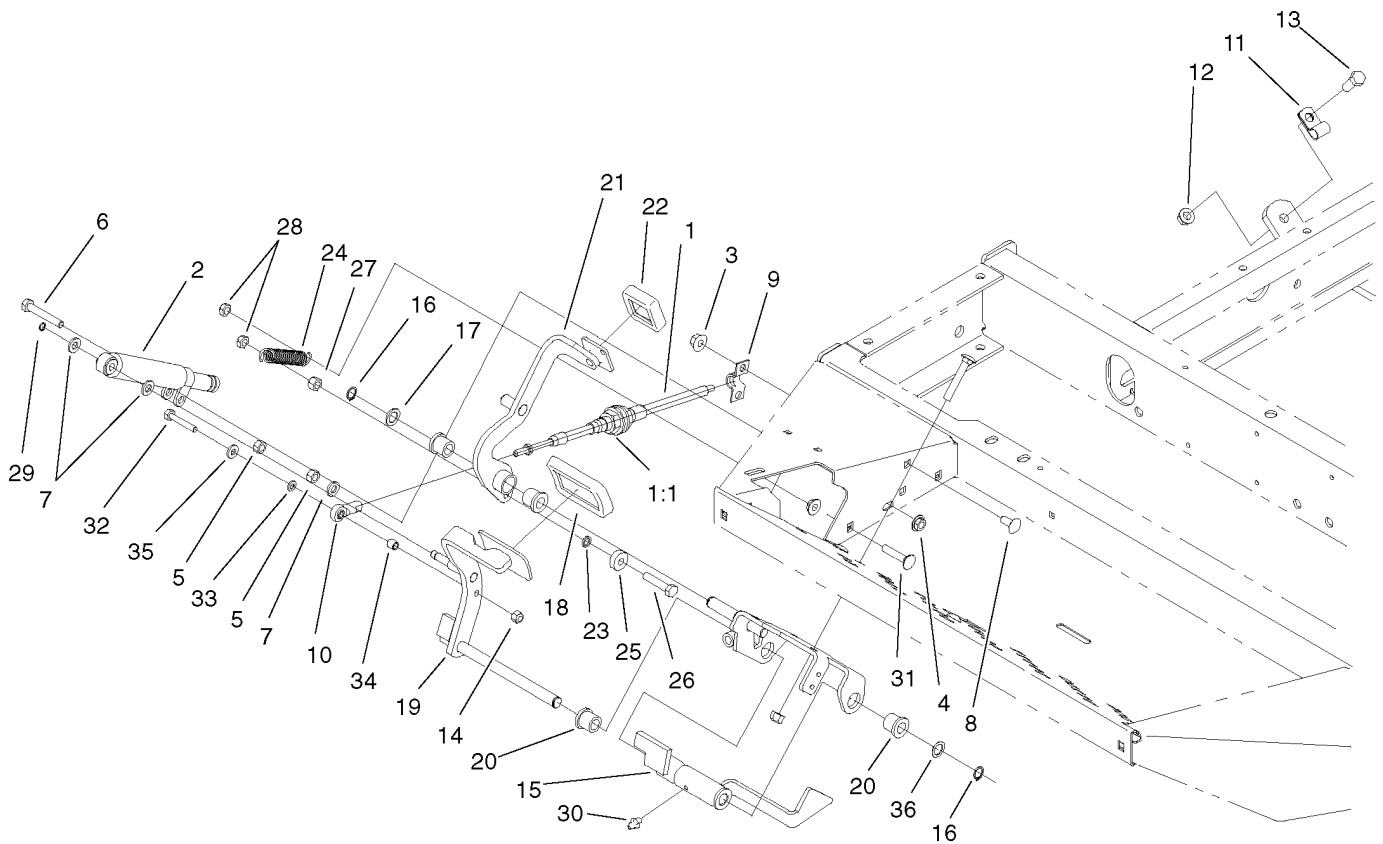

Traction Pedal Assembly

Ref	Part No.	Qty.	Description
1	100-4815	1	Cable-Control, Traction
1:1	3220-1	2	Nut-Jam
2	76-8870	1	Lever Damper ASM
3	32128-20	2	Nut-HF
4	32128-44	2	Nut
5	3217-6	2	Nut-Hex
6	322-10	1	Screw-HH
7	3256-23	3	Washer-Flat
8	3230-23	2	Screw-CARR
9	93-2092	1	Clamp-Cable
10	2411-41	1	Joint-Ball, Superior
11	2412-10	1	R-Clamp
12	32128-43	1	Nut-Flange
13	323-6	1	Screw-HH
14	3296-42	1	Nut-Lock
15	95-8861	1	Slide
16	32151-84	2	Ring-Shaft, EXT
17	41-8440	1	Washer
18	74-9100	1	Pad-Pedal, Forward
19	100-4875-03	1	Traction Pedal ASM
20	256-243	2	Bearing-Flange
21	99-3379	1	Pedal-Reverse
22	74-9110	1	Pad-Pedal, Reverse
23	75-5470	1	Spacer-Bearing

Ref	Part No.	Qty.	Description
24	99-3476	1	Spring-Extension
25	251-259	1	Bearing
26	322-7	1	Screw-HH
27	3296-29	1	Nut-Lock
28	3296-47	2	Nut-Lock, NI
29	32151-3	1	Ring-Grip, Ex
30	302-5	1	Fitting-Grease
31	3230-27	1	Screw-CARR
32	321-9	1	Screw-HH
33	33093-00	1	Washer-Flat
34	99-3545	1	Spacer
35	3256-22	1	Washer-Flat
36	73-0040	4	Washer-Thrust

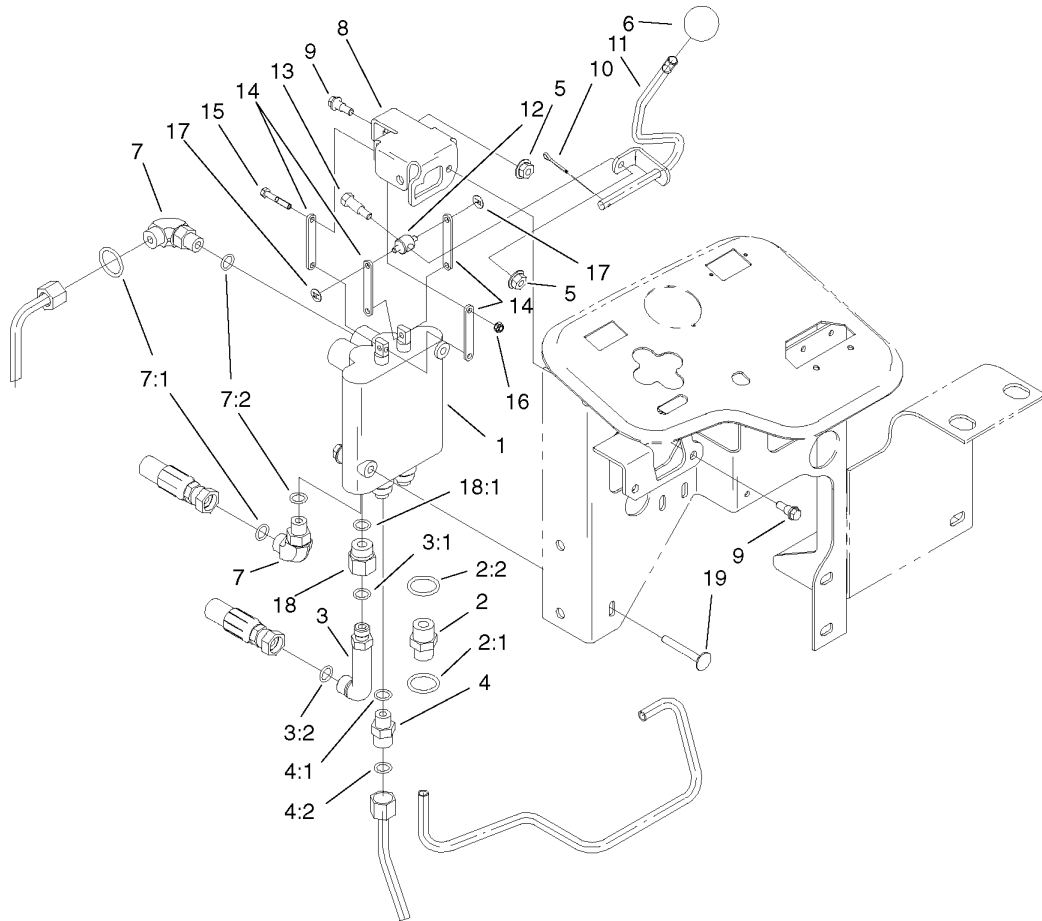

Control Valve Installation Assembly

Ref	Part No.	Qty.	Description	Ref	Part No.	Qty.	Description
1	95-8581	1	Valve-2 Spool	17	93-3988	2	Pushnut-Tinnerman
2	340-3	1	Adapter	18	353-397	1	Reducer-Adapter
2:1	237-22	1	O-Ring	18:1	237-79	1	O-Ring
2:2	237-79	1	O-Ring	19	3230-33	2	Screw-CARR
3	69-4320	1	Fitting-90Ø				
3:1	237-22	1	O-Ring				
3:2	237-42	1	O-Ring				
4	340-2	1	Adapter				
4:1	237-22	1	O-Ring				
4:2	237-42	1	O-Ring				
5	32128-33	5	Nut-HF				
6	233-42	1	Knob				
7	340-77	2	Fitting-90Ø				
7:1	237-22	1	O-Ring				
7:2	237-42	1	O-Ring				
8	95-8633	1	Bracket-Valve, Actuator				
9	42-3560	2	Bolt-Shoulder				
10	3272-6	1	Pin-Cotter				
11	95-8635	1	Lever-Valve				
12	95-8638	1	Trunnion-Valve, Actuator				
13	92-8916	1	Bolt-Shoulder				
14	95-8634	4	Link				
15	87-5150	3	Bolt				
16	87-5140	3	Nut-Lock				

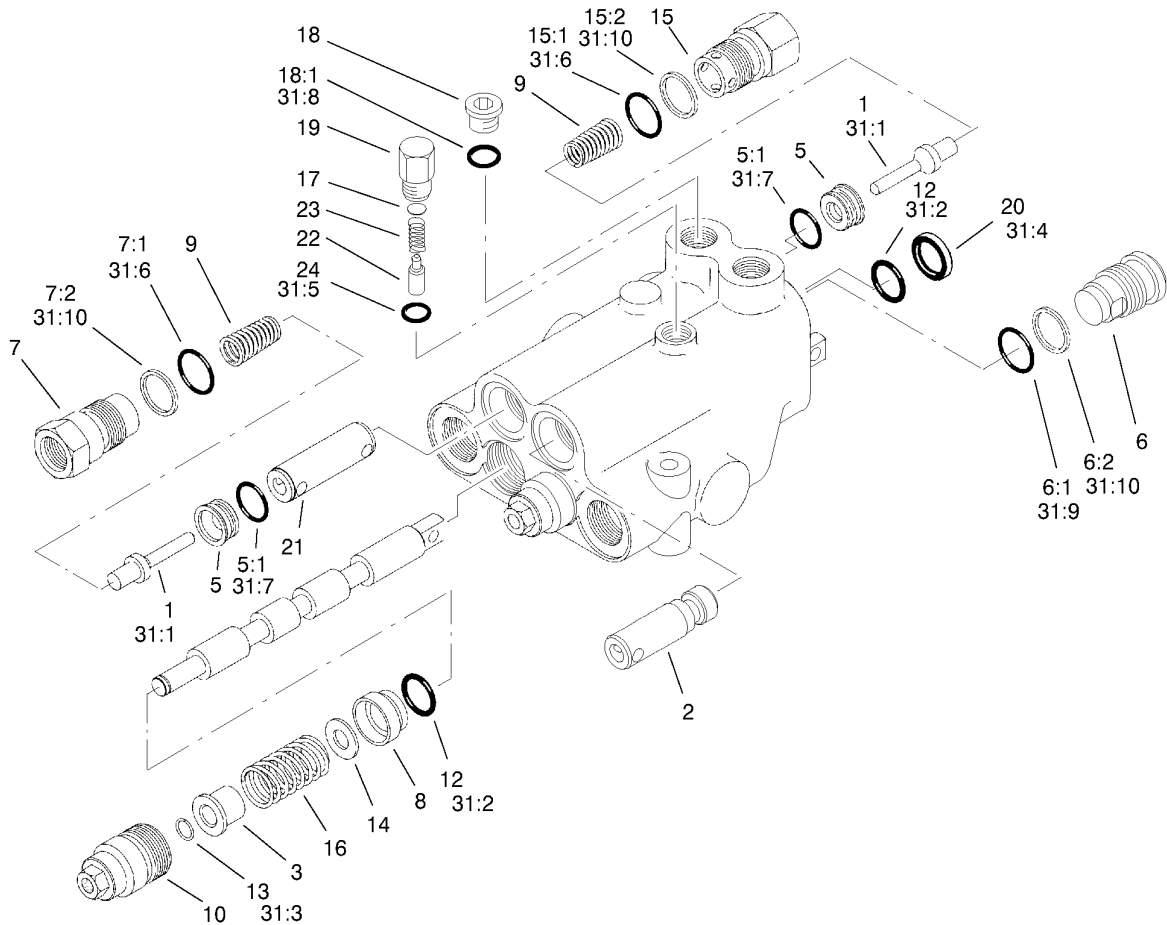

Control Valve Assembly No. 95-8581

Ref	Part No.	Qty.	Description
1	58-6290	3	Poppet
2	69-1840	1	Plunger
3	58-6310	2	Spacer
5	58-6330	3	Seat
5:1	58-6340	1	O-Ring
6	58-6350	1	Plug
6:1	60-5720	1	Ring
6:2	59-7730	1	Washer-Backup
7	99-3527	2	Plug ASM
7:1	60-5720	1	Ring
7:2	59-7730	1	Washer-Backup
8	58-6400	2	Bushing
9	69-1810	3	Spring
10	58-6420	2	Cap
12	58-6450	4	O-Ring
13	58-6460	2	Ring
14	65-2770	2	Washer
15	99-3526	1	Plug ASM
15:1	60-5720	1	Ring
15:2	59-7730	1	Washer-Backup
16	99-3531	2	Spring
17	60-6450	1	Disc
18	353-989	1	Plug-Hex, Hollow
18:1	237-42	1	O-Ring

Ref	Part No.	Qty.	Description
19	58-6780	1	Plug
20	58-6320	2	Wiper
21	99-3528	1	Plunger
22	58-6770	1	Plunger
23	58-6760	1	Spring
24	58-6790	1	O-Ring
31	99-3530	1	Kit-Seal
31:1	58-6290	3	Poppet
31:2	58-6450	4	O-Ring
31:3	58-6460	2	Ring
31:4	58-6320	2	Wiper
31:5	58-6790	1	O-Ring
31:6	60-5720	2	Ring
31:7	58-6340	2	O-Ring
31:8	237-42	1	O-Ring
31:9	60-5720	2	Ring
31:10	59-7730	2	Washer-Backup

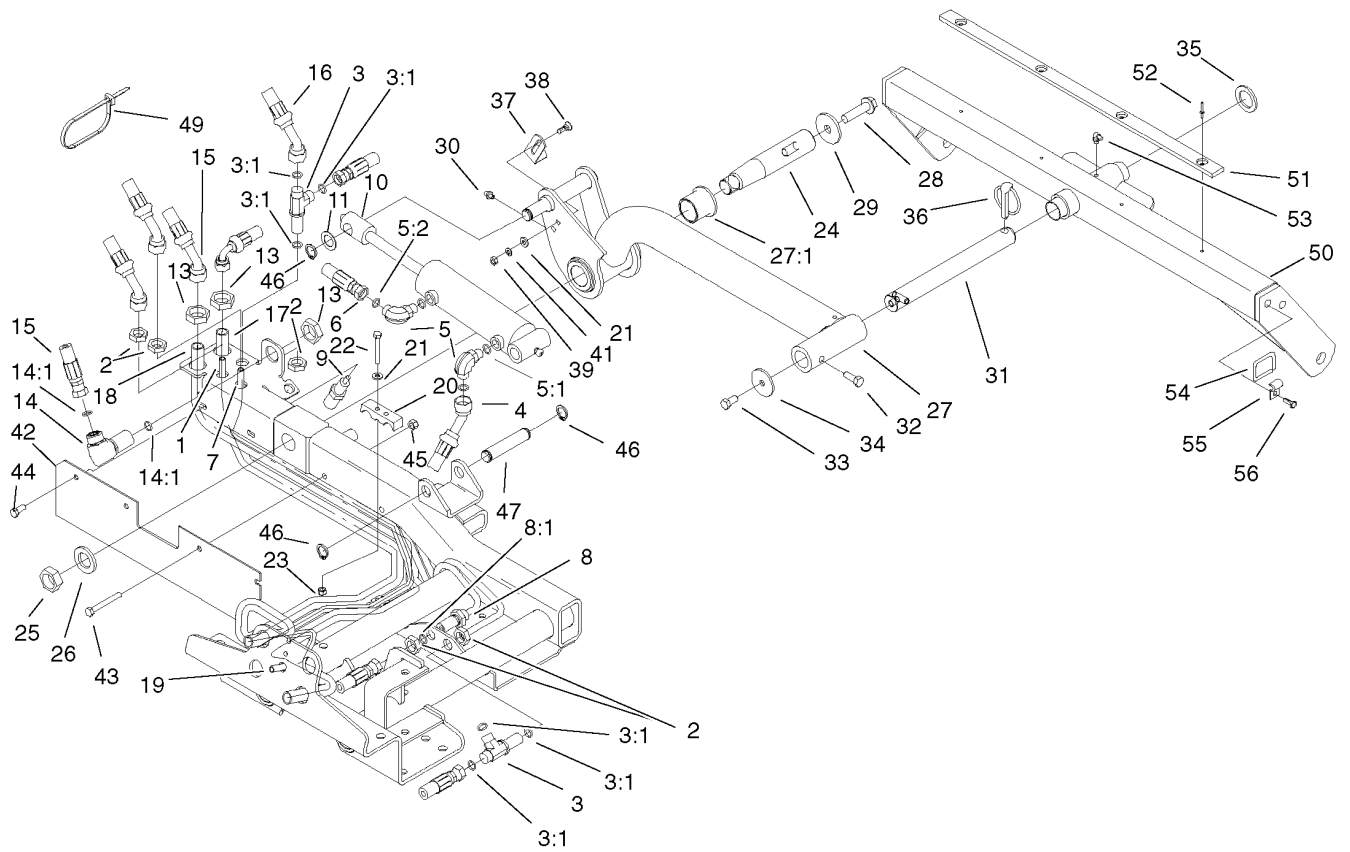

Rear Liftarm Assembly

Ref	Part No.	Qty.	Description
1	104-0402	1	Tube ASM
2	340-70	5	Locknut-Bulkhead
3	340-68	2	Fitting-Tee, Bulkhead
3:1	237-22	6	O-Ring
4	104-0407	1	Hose ASM
5	340-77	2	Fitting-90Ø
5:1	237-22	1	O-Ring
5:2	237-42	1	O-Ring
6	100-4891	1	Hose ASM
7	104-0403	1	Tube ASM
8	340-71	1	Fitting-Straight, Bulkhead
8:1	237-22	2	O-Ring
9	93-6762	1	Switch-Ball
10	95-8978	1	Cylinder-Hydraulic
11	3-6498	1	Washer-Thrust
13	340-74	3	Locknut-Bulkhead
14	340-72	1	Elbow-Bulkhead Union, 90Ø
14:1	237-65	2	O-Ring
15	100-4879	2	Hose ASM
16	95-8825	1	Hose ASM
17	104-0401	1	Tube ASM
18	104-0400	1	Tube-ASM
19	104-0404	1	Tube ASM
20	99-3641	2	Clamp-Tube

Ref	Part No.	Qty.	Description
21	3256-22	6	Washer-Flat
22	321-11	2	Screw-HH
23	3296-42	2	Nut-Lock
24	95-8990	1	Shaft-Pivot, Rear
25	3220-9	1	Nut-Jam
26	86-1480	1	Washer
27	100-4938	1	Rear Lift Arm ASM
27:1	69-6470	2	Bushing-Castor
28	3234-27	1	Screw-Flange
29	75-7730	1	Washer-Thrust
30	302-5	1	Fitting-Grease
31	100-4944	1	Shaft-C.U., Pivot
32	323-6	1	Screw-HH
33	323-4	1	Screw-HH
34	63-7400	1	Washer-Rebound
35	3-6781	1	Washer-Thrust
36	283-71	1	Pin-Lynch
37	95-8613	1	Bracket-Switch
38	3229-1	2	Screw-CARR
39	3217-5	2	Nut-Hex
41	3253-3	2	Washer-Lock/Sp
42	104-0453-03	1	Guard
43	322-12	2	Screw-HH
44	322-3	2	Screw-HH

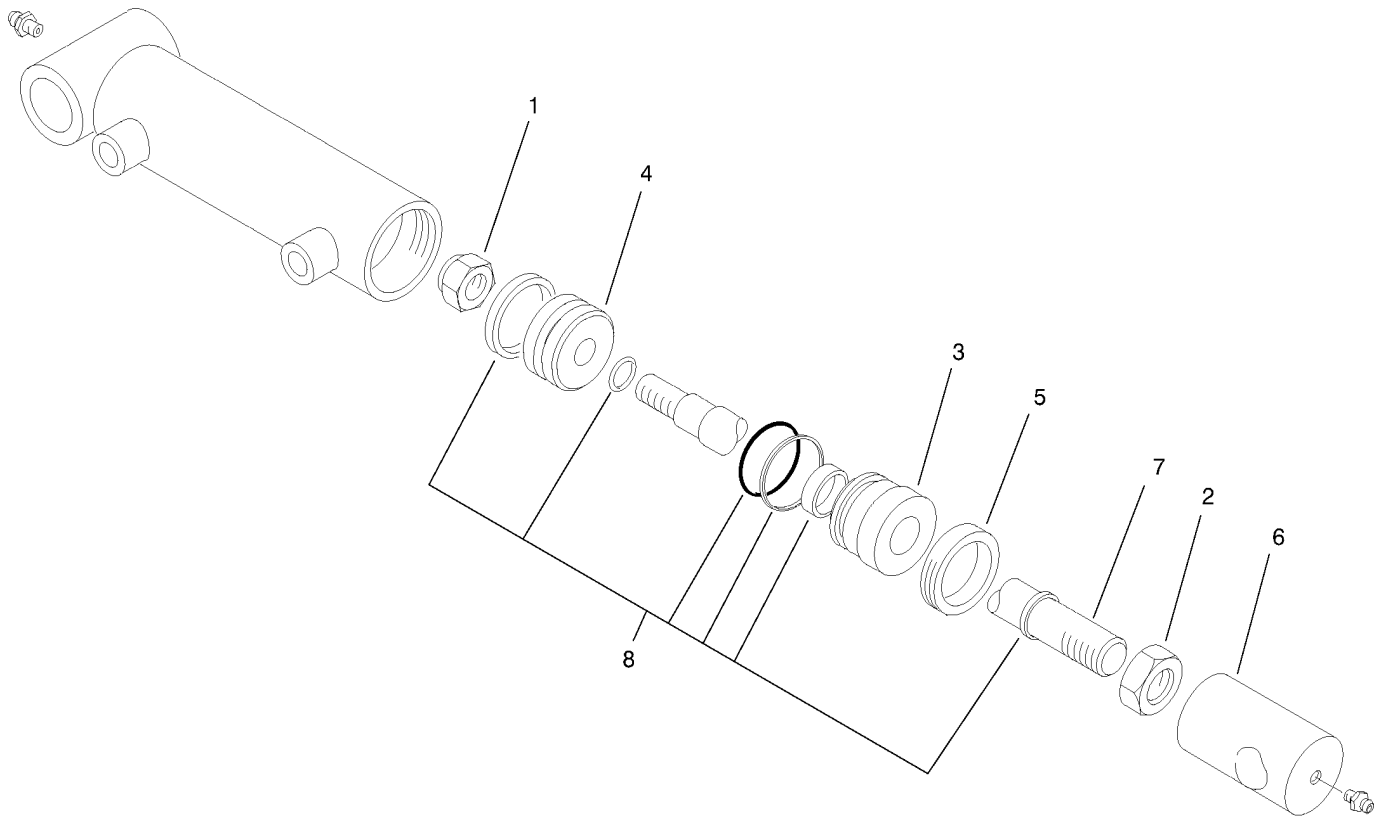

Hydraulic Cylinder Assembly No. 95-8978

Ref	Part No.	Qty.	Description
1	32152-10	1	Locknut-Deform, Top
2	3220-6	1	Nut-Jam
3	65-4860	1	Head
4	52-1990	1	Piston-Cylinder, Hydraulic
5	99-3532	1	Collar-Internal
6	99-3533	1	Clevis
7	99-3534	1	Shaft
8	83-7240	1	Kit-Repair, Seal

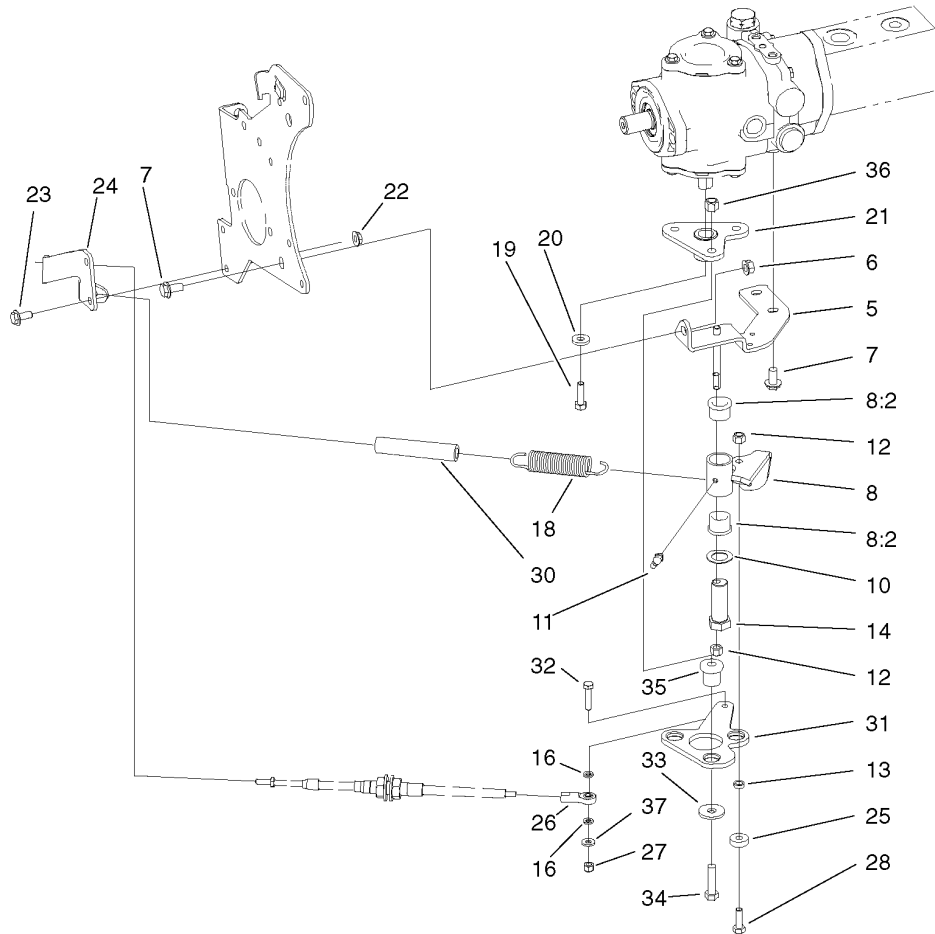

Neutral Arm Assembly

Ref	Part No.	Qty.	Description
5	95-8960-03	1	Bracket-Neutral
6	32128-43	1	Nut-Flange
7	3234-1	3	Screw-HHF
8	104-0422	1	Neutral Arm ASM
8:2	256-113	2	Bushing-Flange
10	3-6498	1	Washer-Thrust
11	302-60	1	Fitting-Lube
12	3296-29	2	Nut-Lock
13	100-4817	1	Spacer-Bearing
14	76-8640	1	Stud-Traction
16	33093-00	2	Washer-Flat
18	94-1369	1	Spring-Extension
19	3210-6	1	Screw-HH
20	88-7200	1	Washer-Flat
21	99-3598-03	1	Hub ASM
22	32128-44	2	Nut
23	3234-5	2	Screw-HHF
24	104-0464-03	1	Bracket-Support, Cable
25	251-259	1	Bearing
26	2411-41	1	Joint-Ball, Superior
27	3296-42	1	Nut-Lock
28	3274-104	1	Screw-HSBH
30	99-3556	1	Hose
31	99-3594-03	1	Lever-Pump

Ref	Part No.	Qty.	Description
32	321-8	1	Screw-HH
33	2844	3	Washer
34	95-3857	3	Screw-Head, Button
35	63-9750	3	Mount
36	3296-39	3	Nut-Lock, NI
37	3256-22	1	Washer-Flat

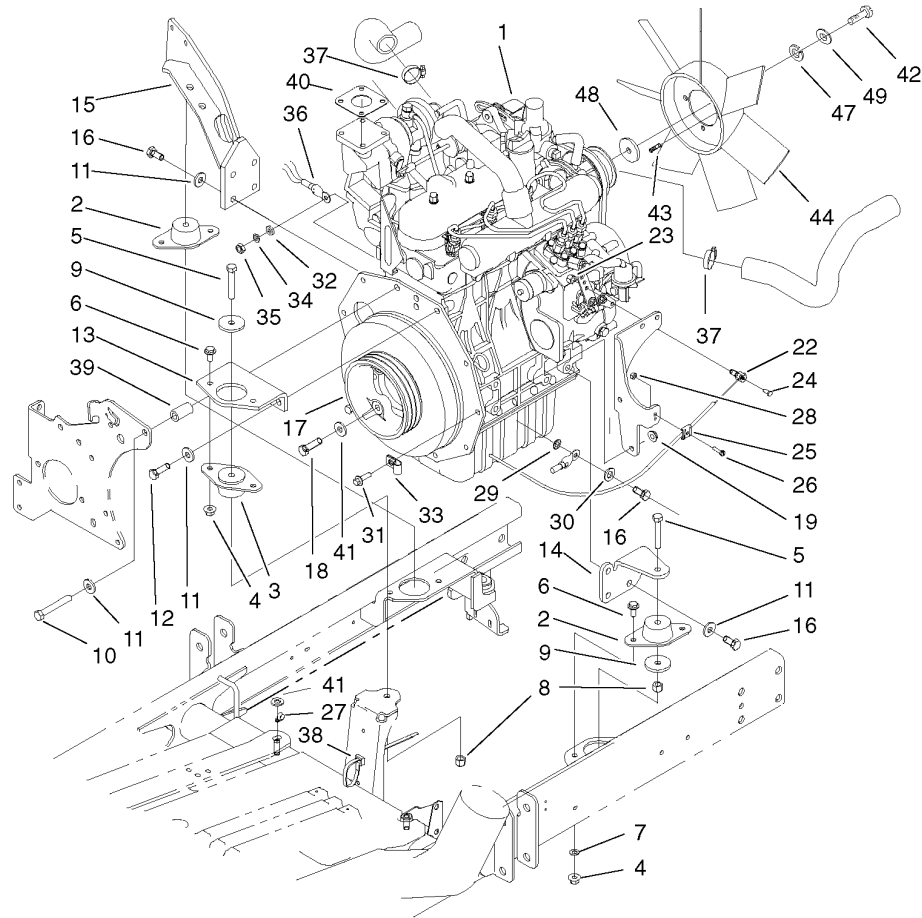

Engine Assembly

Ref	Part No.	Qty.	Description	Ref	Part No.	Qty.	Description
1	100-4901	1	Engine-Kubota, D1105-T-Eb-Toro-2-S1	26	32105-13	1	Screw-SHH
2	83-1030	2	Mount-Engine	27	2412-112	1	Clamp
3	93-5265	1	Mount-Engine	28	3296-2	1	Nut-Lock
4	32128-20	6	Nut-HF	29	3255-9	1	Washer-Lock/EXT
5	323-11	3	Screw-HH	30	3256-25	1	Washer-Flat
6	3234-5	6	Screw-HHF	31	3234-17	2	Screw-HHF
7	3255-8	1	Washer-Lock/EXT	32	3256-78	1	Washer-Flat
8	3296-39	3	Nut-Lock, NI	33	2412-10	1	R-Clamp
9	80-8560	3	Washer-Hardened	34	43-5930	1	Washer-Spring
10	42-9370	1	Bolt/Washer	35	48-7890	1	Nut
11	80-6990	9	Washer-Hardened	36	99-3441	1	Harness-Wire, Fusible Link
12	95-8812	1	Screw-Hhc	37	2412-34	2	Clamp-Hose
13	99-3618-03	1	Mount-Engine, Front	38	3290-378	1	Tie-Cable
14	95-8937-03	1	Mount-Engine, LH	39	95-8736	1	Spacer
15	100-4838-03	1	Mount-Engine	40	98-9611	1	Gasket
16	63-7790	8	Screw-Cap	41	3256-24	4	Washer-Flat
17	99-3626-03	1	Pulley-3V, Engine	42	33103-030	4	Screw-HHF
18	56-2140	3	Bolt	44	104-4246	1	Fan-Engine
19	32128-44	2	Nut	47	3253-3	4	Washer-Lock/Sp
22	98-9311	1	Swivel-Throttle	48	104-4247	1	Spacer-Fan
23	3296-20	1	Nut-Lock NI	49	3256-22	4	Washer-Flat
24	25-8640	1	Screw-Machine, HH				
25	81-1690	1	Clamp-Cable				

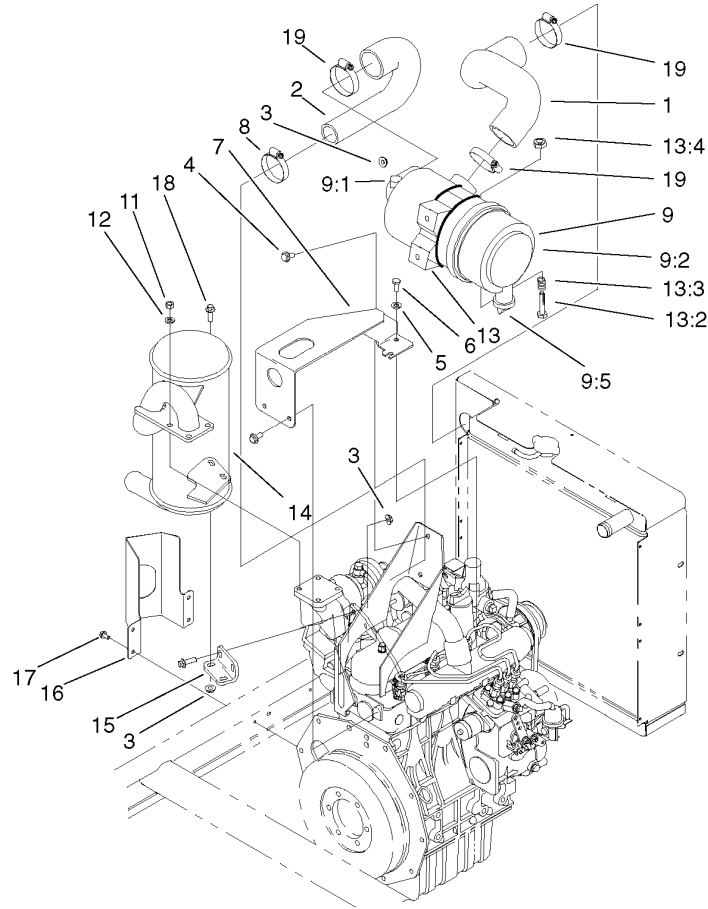

Air Cleaner And Muffler Assembly

Ref	Part No.	Qty.	Description
1	104-0420	1	Hose-Air Intake, Upper
2	99-3643	1	Hose-Air Intake, Lower
3	32128-44	6	Nut
4	3234-5	3	Screw-HHF
5	3256-23	4	Washer-Flat
6	33114-016	4	Screw-HH
7	99-3648-03	1	Mount-Filter, Air
8	2412-92	1	Clamp-Hose
9	100-4824	1	Air Cleaner ASM
9:1	285-17	1	Plug-Pipe
9:2	104-0497	1	Cover ASM
9:5	104-0498	1	Valve-Vacuator
9:6	98-9763	1	Element ASM
11	33014-00	4	Nut-Hex
12	42-9850	4	Washer-Lock, Spring
13	100-4825	1	Band-Mouning, Air Cleaner
13:2	94-3653	1	Bolt
13:3	94-3654	1	Spring
13:4	48-9510	1	Nut
14	100-4810	1	Muffler
15	95-8943-03	1	Bracket-Muffler
16	99-3425-03	1	Guard-Exhaust
17	32144-4	4	Screw-HH
18	3234-17	3	Screw-HHF

Ref	Part No.	Qty.	Description
19	2412-130	3	Hose Clamp

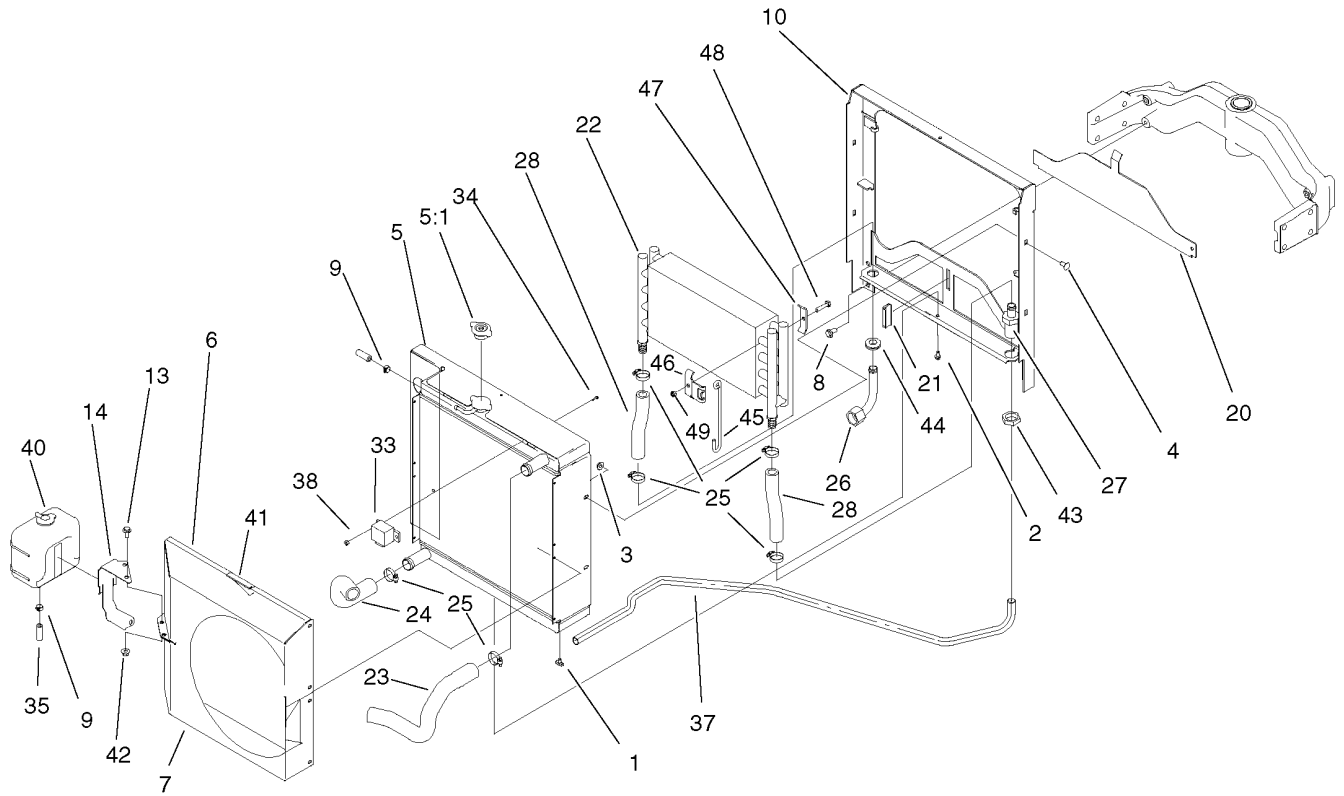

Radiator Assembly

Ref	Part No.	Qty.	Description
1	304-46	1	Draincock
2	32104-116	12	Screw
3	32128-44	4	Nut
4	3230-1	4	Screw-CARR
5	99-3637	1	Radiator
5:1	93-5957	1	Cap-Radiator
6	100-4885-03	1	Shroud-Fan, Top
7	100-4898-03	1	Shroud-Fan, Bottom
8	3234-1	4	Screw-HHF
9	92-2379	2	Clamp-Hose
10	100-4802-03	1	Frame-Radiator
13	3234-5	2	Screw-HHF
14	100-4899-03	1	Bracket-Reservoir
20	95-8702-03	1	Shield-Radiator, Lower
21	99-3497	1	Magnet
22	100-4869	1	Cooler-Oil
23	104-0454	1	Hose-Radiator, Upper
24	100-4809	1	Hose-Radiator, Lower
25	2412-34	6	Clamp-Hose
26	99-3644	1	Filter Head Tube ASM
27	100-4925	1	Fitting-Bulkhead
28	99-3646	2	Hose-Cooler, Oil
33	66-8800	1	Relay
34	32105-13	2	Screw-SHH

Ref	Part No.	Qty.	Description
35	63-7623	1	Hose-Fuel
37	100-4924	1	Tube ASM
38	3296-2	2	Nut-Lock
40	98-9323	1	Bottle-Overflow, Water
41	93-6681	1	Decal-Warning, Fan
42	32128-20	2	Nut-HF
43	340-126	1	Nut-Bulkhead
44	100-4866	1	Grommet
45	100-4858	2	Form-Wire
46	100-4859	2	Bracket-Cooler, Keeper
47	100-4860	2	Bracket-Clamp
48	322-17	2	Screw-HH
49	3296-47	2	Nut-Lock, NI

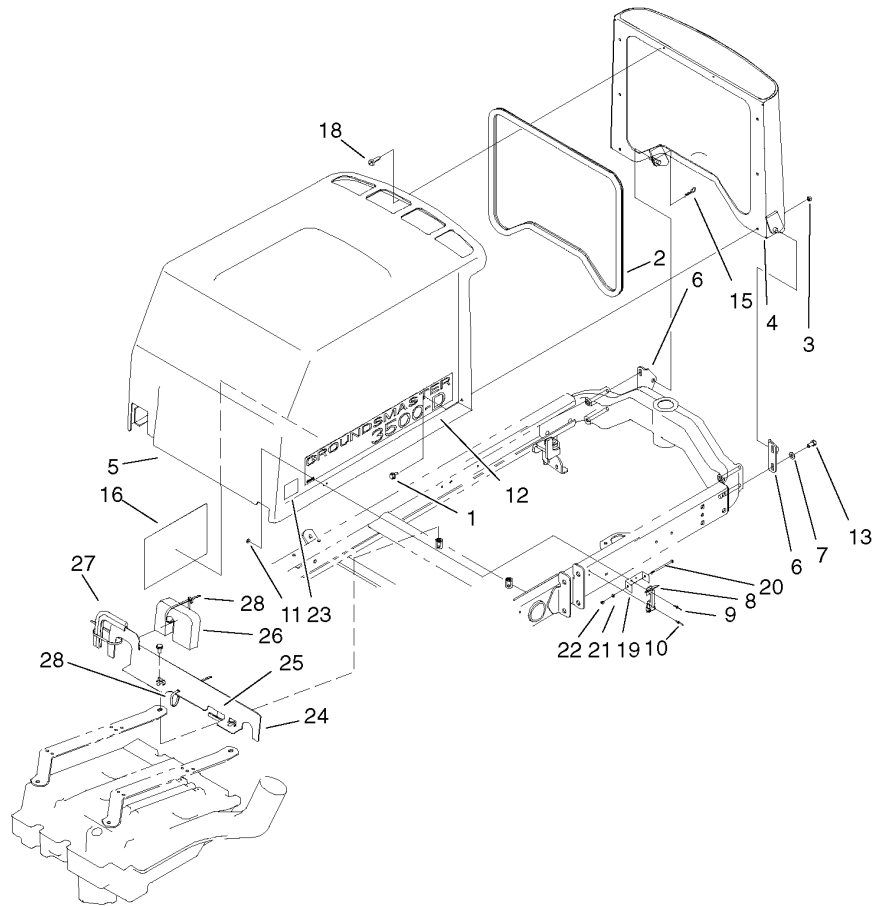

Hood-Screen Assembly

Ref	Part No.	Qty.	Description
1	3234-4	6	Screw-HHF
2	100-4932	1	Trim-Seal
3	3296-42	6	Nut-Lock
4	100-4847-03	1	Screen-Hood
5	100-4855	1	Hood
6	95-8728	2	Bracket-Pivot, Hood
7	3256-24	4	Washer-Flat
8	59-9740	2	Flex Draw Latch ASM
9	98-7310	4	Rivet
10	3290-55	4	Rivet-Pop
11	3269-10	4	Washer-Back
12	104-0446	2	Decal
13	323-4	4	Screw-HH
15	3290-467	1	Pin-Hair
16	104-0483	1	Decal-Instructions, Service
18	32104-116	2	Screw
19	99-3568	1	Bracket-Lock,Ce
20	321-9	1	Screw-HH
21	3256-22	1	Washer-Flat
22	3296-42	1	Nut-Lock
23	100-6574	1	Decal-Warning
24	104-4800-03	1	Shield-Heat
25	104-4818	1	Foam-Cell, Closed
26	104-4822	1	Strip-Seal

Ref	Part No.	Qty.	Description
27	104-4823	1	Strip-Seal, Bubble
28	3290-378	3	Tie-Cable

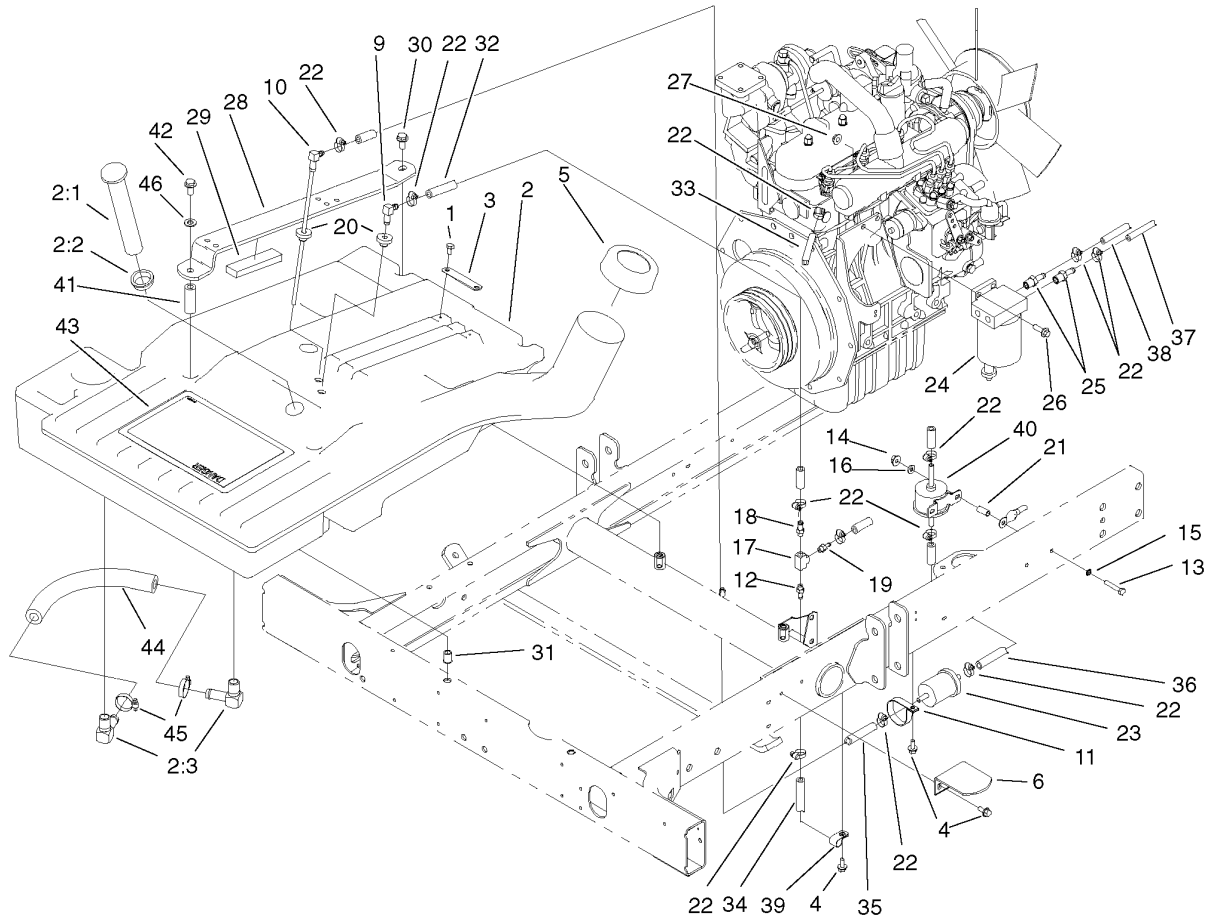

Fuel System Assembly

Ref	Part No.	Qty.	Description
1	321-2	2	Screw-HH
2	104-0408	1	Tank-Fuel
2:1	95-8971	1	Guage-Fuel
2:2	95-8972	1	Grommet
2:3	353-377	2	Stem-Hose
3	95-8881	1	Strap-Line, Fuel
4	32144-10	4	Screw-HWH
5	95-4193	1	Diesel Gas Cap ASM
6	95-8968-03	1	Support-Tank, Fuel
9	46-6550	1	Elbow-Connector, 90°
10	66-8121	1	Standpipe
11	2412-148	1	Clamp-R
12	304-73	1	Connector-Hose
13	321-9	2	Screw-HH
14	32128-33	2	Nut-HF
15	3255-7	1	Washer-Lock/EXT
16	3256-22	2	Washer-Flat
17	354-20	1	Fitting-Tee
18	354-21	1	Fitting-Barb
19	354-22	1	Fitting-Barb
20	46-6560	2	Bushing
21	87-4710	2	Spacer-Brake, Parking
22	2412-108	13	Clamp-Worm
23	98-7612	1	Filter-Fuel

Ref	Part No.	Qty.	Description
24	98-9305	1	Filter-Water/Fuel
25	353-783	2	Fitting-Pump
26	3234-17	2	Screw-HHF
27	32128-44	2	Nut
28	104-0467-03	2	Strap-Support, Seat
29	95-8896	2	Foam
30	3234-1	2	Screw-HHF
31	32148-9	2	Nut-Insert
32	71-3380	1	Hose-Fuel
33	99-3498	1	Return-Line, Fuel
34	99-3185	1	Line-Fuel
35	71-3383	1	Hose-Fuel
36	19-3250	1	Hose-Line, Fuel
37	63-9640	1	Hose
38	27-2120	1	Hose-Line, Gas
39	2412-73	1	Clamp-R
40	99-3464	1	Pump-Fuel
41	104-0466	2	Spacer-Tube
42	323-14	2	Screw-HH
43	104-0484	1	Decal
43	99-3560	1	Decal-Danger, Ce
44	104-0465	1	Hose
45	2412-34	2	Clamp-Hose
46	3256-24	2	Washer-Flat

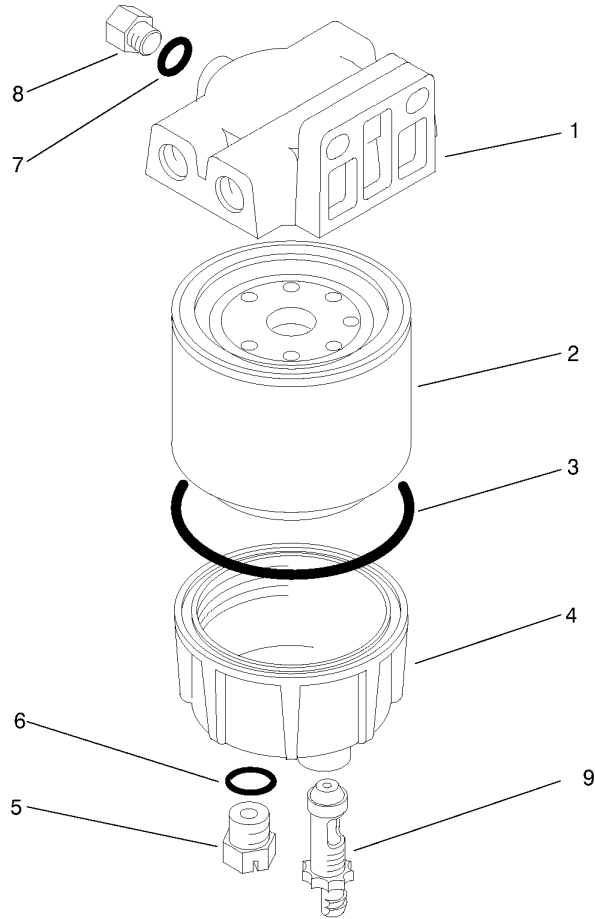

Water / Fuel Filter Assembly No. 98-9305

Ref	Part No.	Qty.	Description				
1	98-9772	1	Head-Filter				
2	98-9764	1	Element-On, Spin				
3	98-9774	1	O-Ring-Base, Filter				
4	98-9775	1	Base-Filter				
5	98-9773	1	Plug-Base, Filter				
6	237-42	1	O-Ring				
7	237-78	1	O-Ring				
8	98-9776	1	Plug-Filter, Head				
9	98-9777	1	Drain Valve ASM				

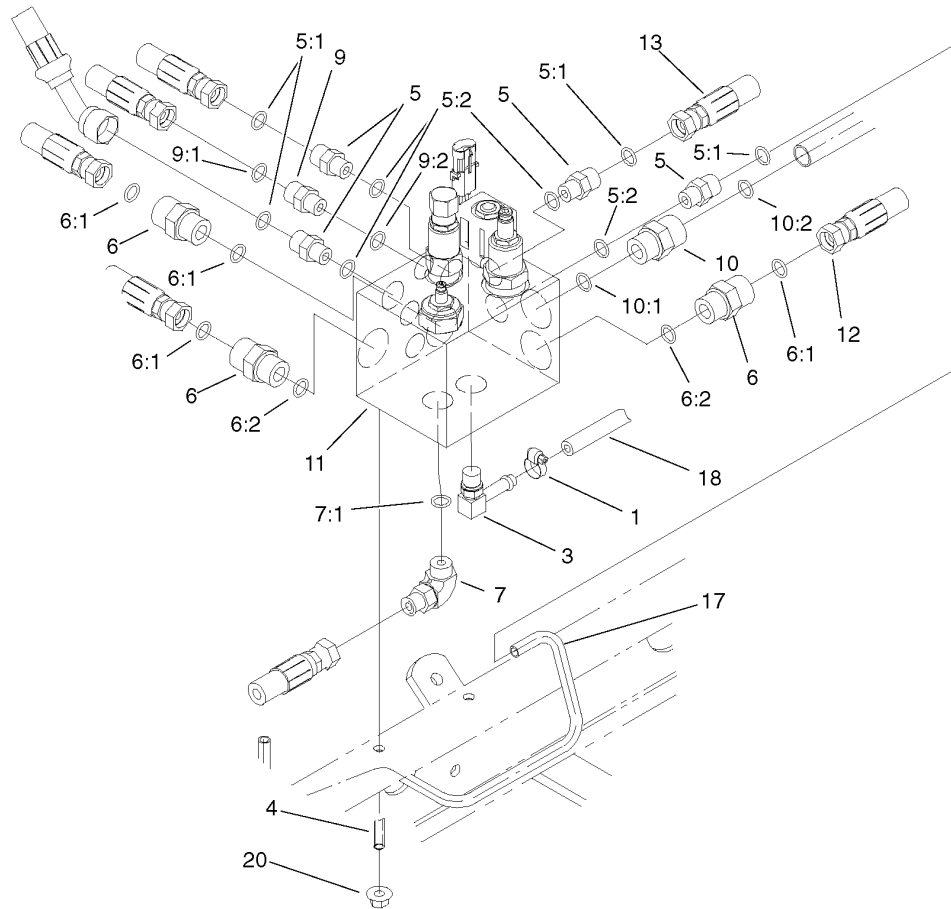

Manifold Block Installation Assembly

Ref	Part No.	Qty.	Description
1	2412-108	1	Clamp-Worm
3	100-4887	1	Fitting-Barb
3:1	237-42	1	O-Ring
4	104-0430	2	Stud
5	340-2	4	Adapter
5:1	237-22	1	O-Ring
5:2	237-42	1	O-Ring
6	340-7	3	Adapter
6:1	237-65	1	O-Ring
6:2	237-80	1	O-Ring
7	340-77	1	Fitting-90°
7:1	237-22	1	O-Ring
7:2	237-42	1	O-Ring
9	340-88	1	Adapter
9:1	237-22	1	O-Ring
9:2	237-78	1	O-Ring
10	340-66	1	Fitting-Hydraulic
10:1	237-80	1	O-Ring
10:2	237-58	1	O-Ring
11	100-4826	1	Manifold Block ASM
12	104-0488	1	Hose ASM
13	100-4889	1	Hose ASM
17	100-4827	1	Tube ASM
18	80-7342	1	Hose ASM

Ref	Part No.	Qty.	Description
20	32128-20	2	Nut-HF

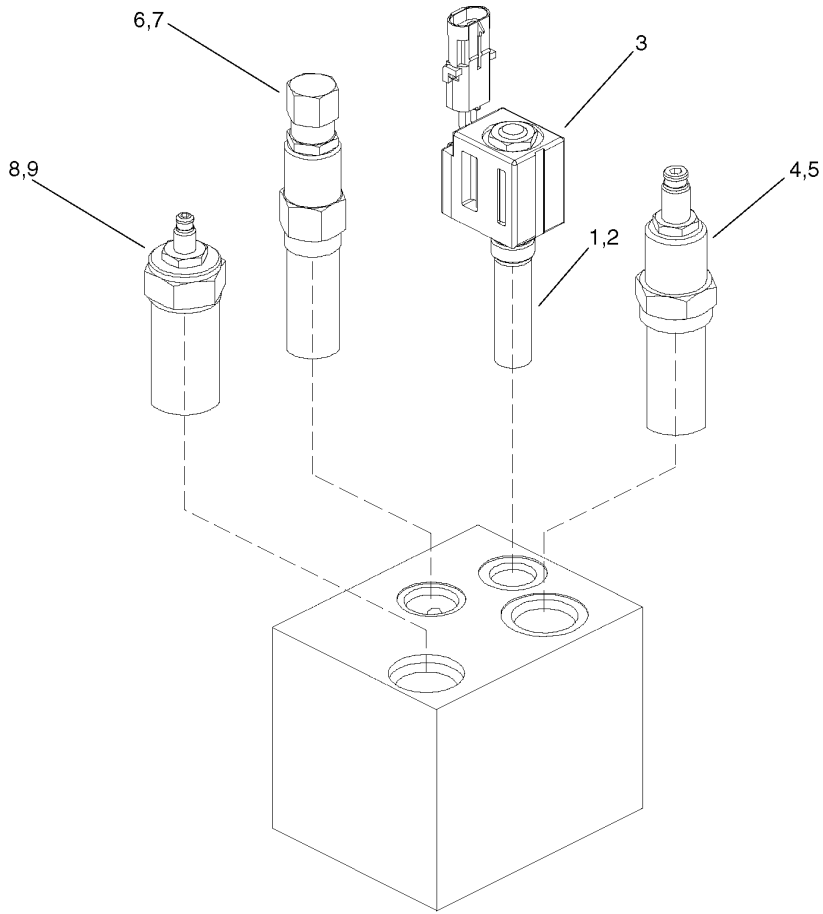

Manifold Block Assembly No. 100-4826

Ref	Part No.	Qty.	Description
1	104-4262	1	Valve-Solenoid
2	104-4263	1	Seal Kit
3	104-4264	1	Coil-Solenoid
4	104-4265	1	Valve-Relief,Vented
5	104-4266	1	Seal Kit
6	104-4267	1	Cartridge-Logic
7	104-4268	1	Seal Kit
8	104-4269	1	Valve-Braking
9	104-4270	1	Seal Kit

--	--	--	--

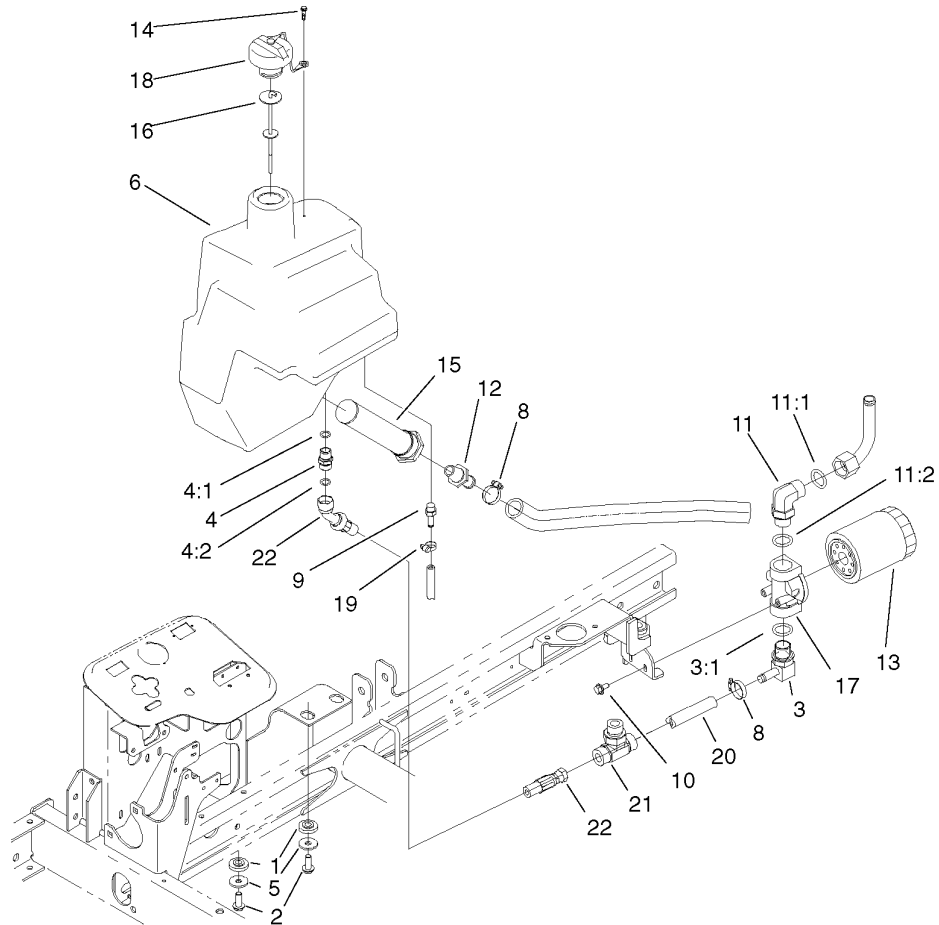

Hydraulic Tank Assembly

Ref	Part No.	Qty.	Description	Ref	Part No.	Qty.	Description
1	240-11	4	Grommet-Mount, Tank	21	100-4836	1	Fitting-Tee
2	3234-11	4	Screw-HHF	22	104-0487	1	Hose ASM
3	353-987	1	Fitting-HYD. Barb, 90 DEG				
3:1	237-81	1	O-Ring				
4	100-4890	1	Fitting-Check				
4:1	237-79	1	O-Ring				
4:2	237-30	1	O-Ring				
5	63-8410	4	Washer				
6	100-4814	1	Tank-Hydraulic				
8	2412-34	2	Clamp-Hose				
9	353-979	1	Fitting-Barb, Straight				
10	3234-13	2	Screw-HHF				
11	340-142	1	Elbow-90Ø				
11:1	237-58	1	O-Ring				
11:2	237-81	1	O-Ring				
12	100-4835	1	Fitting-Barb				
13	54-0110	1	Filter-Oil, Transmission				
14	57-5420	1	Screw-Shoulder				
15	75-0550	1	Suction-Strainer				
16	75-3710	1	Dipstick				
17	92-5821	1	Filter Head ASM				
18	93-7160	1	Cap-Oil, Hydraulic				
19	2412-108	1	Clamp-Worm				
20	104-0486	1	Hose ASM				

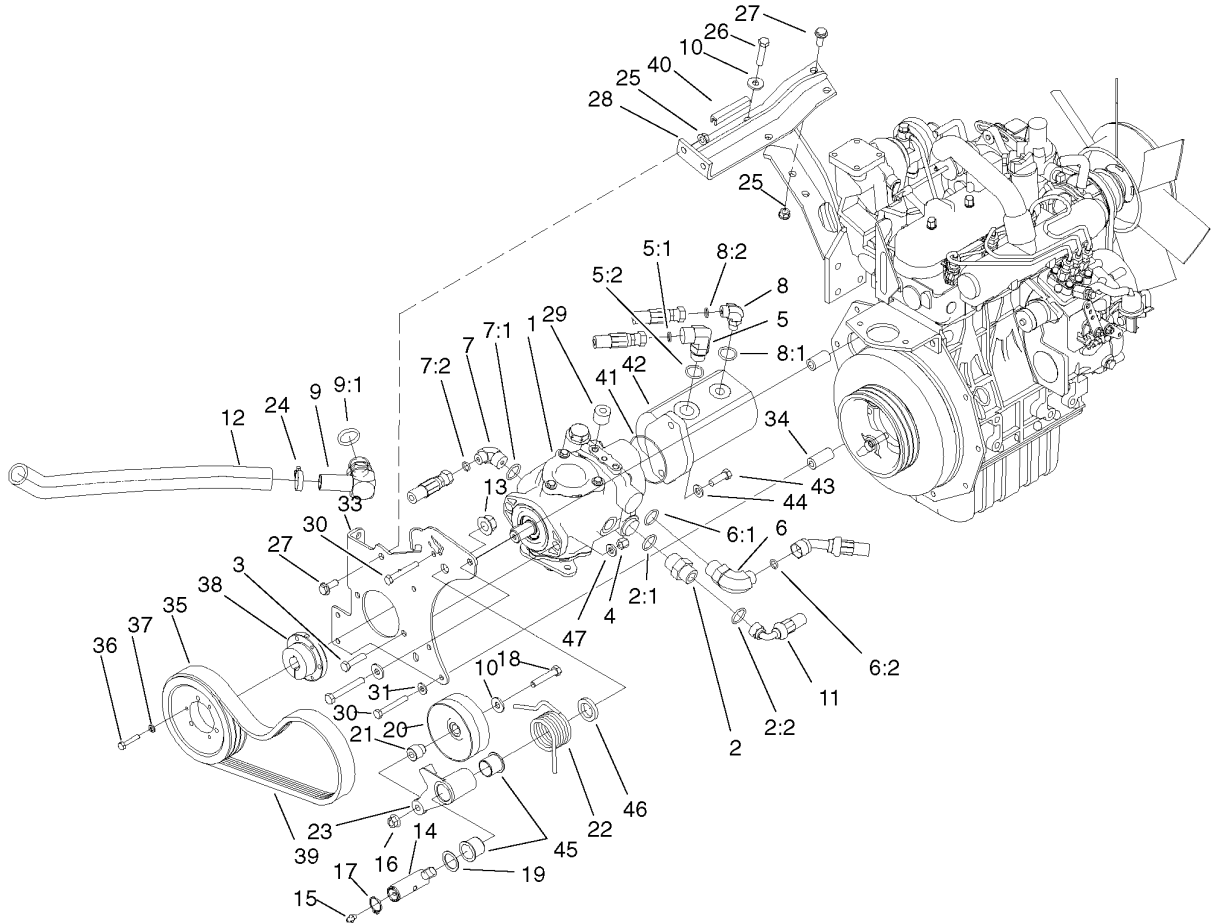

Hydrostat Assembly

Ref	Part No.	Qty.	Description
1	104-0428	1	Pump-Piston
2	340-8	1	Adapter
2:1	237-65	1	O-Ring
2:2	237-81	1	O-Ring
3	323-8	2	Screw-HH
4	3296-39	2	Nut-Lock, NI
5	340-17	1	Adapter
5:1	237-65	1	O-Ring
5:2	237-80	1	O-Ring
6	340-139	1	Fitting-90Ø
6:1	237-81	1	O-Ring
6:2	237-65	1	O-Ring
7	340-18	1	Fitting
7:1	237-79	1	O-Ring
7:2	237-22	1	O-Ring
8	340-77	1	Fitting-90Ø
8:1	237-22	1	O-Ring
8:2	237-42	1	O-Ring
9	353-987	1	Fitting-HYD. Barb, 90 DEG
9:1	237-81	1	O-Ring
10	80-6990	3	Washer-Hardened
11	95-8834	1	Hose ASM
12	104-0489	1	Hose
13	32128-54	1	Nut-Flange

Ref	Part No.	Qty.	Description
14	99-3624	1	Shaft-Pivot, Idler
15	302-5	1	Fitting-Grease
16	32128-21	1	Nut-HF
17	32151-36	1	Ring-Retaining
18	323-10	1	Screw-HH
19	74-1810	1	Washer
20	99-3621	1	Pulley-Idler
21	99-3622	1	Spacer-Idler
22	100-4844	1	Spring-Torsion
23	99-3623-03	1	Arm-Idler
24	2412-34	1	Clamp-Hose
25	32128-43	4	Nut-Flange
26	323-19	2	Screw-HH
27	3234-11	4	Screw-HHF
28	99-3436-03	1	Support-Pump
29	99-3440	2	Spacer
30	33114-060	4	Screw-HH
31	87-8640	3	Washer-Flat
33	95-8933-03	1	Plate-Mount, Pump
34	95-8941	4	Spacer-Mount, Pump
35	99-3620	1	Pulley-3V, Pump
36	321-13	3	Screw-HH
37	3253-3	3	Washer-Lock/Sp
38	100-4813	1	Bushing-Lock, Taper

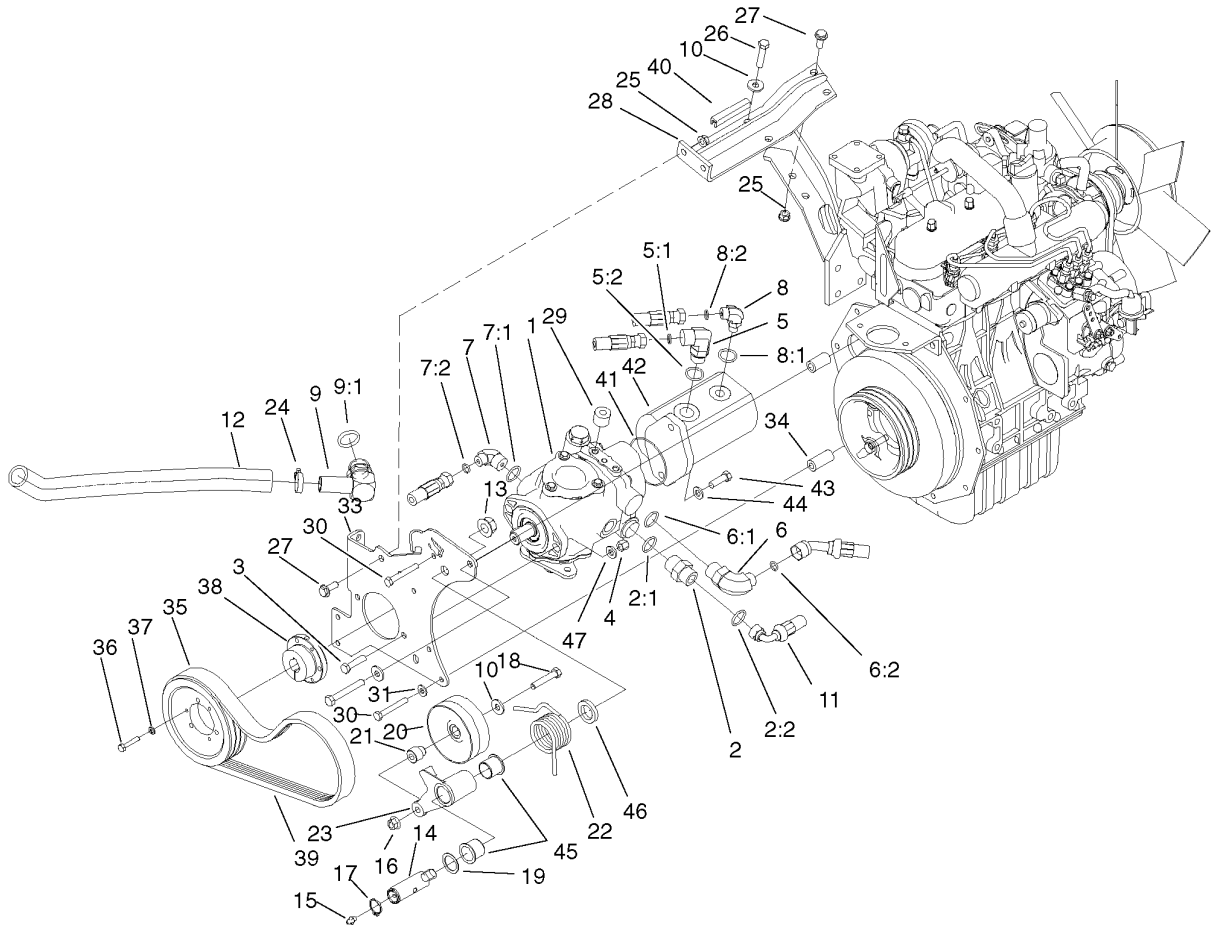

Hydrostat Assembly (continued)

Ref	Part No.	Qty.	Description
39	99-3619	1	Belt-3V
40	70-2041	1	Trim
41	353-949	1	O-Ring
42	100-1646	1	Hydraulic Pump ASM
④*42:1	104-4226	1	Kit-Seal
43	323-7	2	Screw-HH
44	3256-24	2	Washer-Flat
45	99-3631	2	Bushing-Flange
46	99-3625	1	Spacer-Arm, Idler
47	100-4852	2	Washer-Hardened

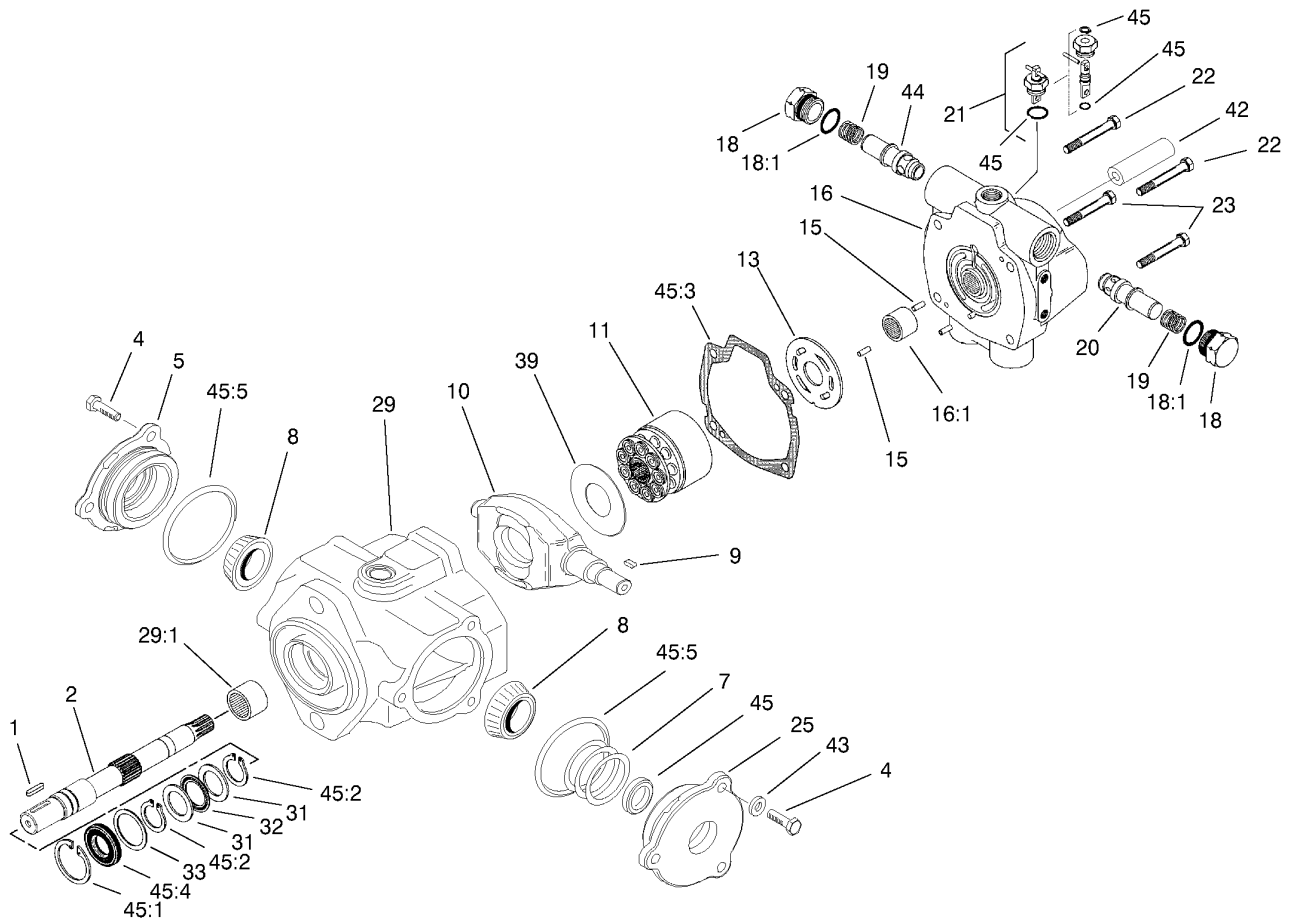

Piston Pump Assembly No. 104-0428

Ref	Part No.	Qty.	Description
1	94-3645	1	Key
2	94-6359	1	Shaft-Drive
4	98-4640	6	Screw-Cap
5	98-4633	1	Cover Plate ASM
7	100-3182	1	Kit-Shim
8	98-4639	2	Bearing-Cone
9	94-3646	1	Key
10	99-3520	1	Plate-Cam
11	76-6070	1	Rotating Kit ASM
13	104-0429	1	Plate-Cam
15	76-6150	2	Pin-Dowel
16	100-3177	1	Back Plate ASM
16:1	94-6368	1	Bearing
18	70-1240	2	Plug ASM
18:1	60-5980	1	O-Ring
19	76-6200	2	Spring
20	94-3644	1	Seat
21	100-3181	1	Dump Valve ASM
22	76-6170	2	Capscrew
23	76-6160	2	Capscrew
25	98-4645	1	Cover Plate ASM
29	100-3176	1	Housing ASM
29:1	94-6363	1	Bearing
31	252-71	2	Bearing-Thrust

Ref	Part No.	Qty.	Description
32	252-66	1	Bearing-Thrust
33	33-3720	1	Washer
39	98-4635	1	Insert-Plate, Cam
42	74-9040	1	Coupler
43	95-6055	6	Washer
44	99-3521	1	Relief Valve ASM
45	98-4636	1	Kit-Repair, Seal
45:1	32151-13	1	Ring-Snap, Internal
45:2	32151-29	1	Ring-Snap, External
45:3	33-4930	1	Gasket-Housing
45:4	42-2720	1	Seal-External
45:5	100-3179	1	O-Ring

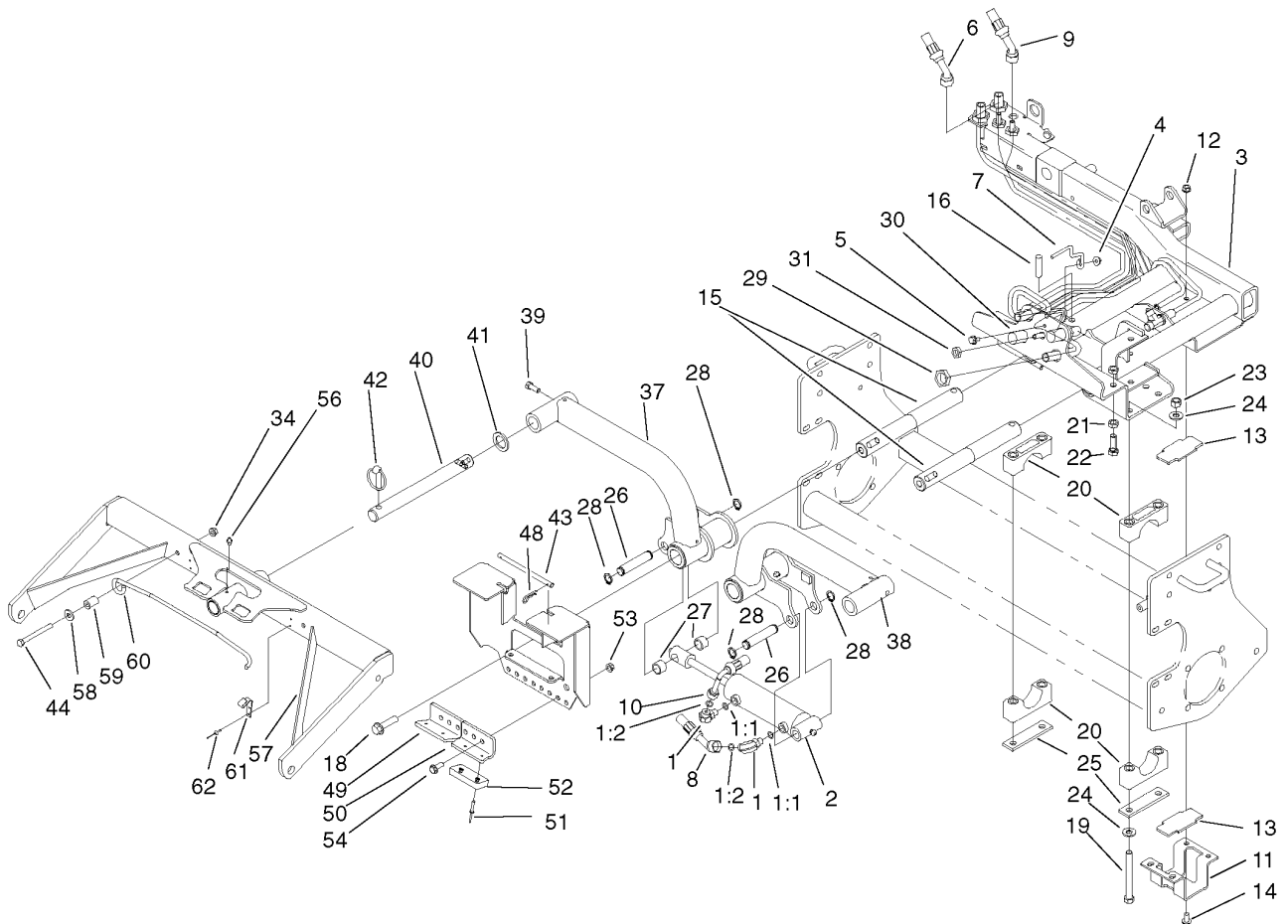

Carrier Assembly

Ref	Part No.	Qty.	Description
1	340-77	2	Fitting-90Ø
1:1	237-22	1	O-Ring
1:2	237-42	1	O-Ring
2	95-8978	1	Cylinder-Hydraulic
3	100-4939-03	1	Sidewinder Carrier ASM
4	32128-33	1	Nut-HF
5	3234-4	1	Screw-HHF
6	95-8822	1	Hose ASM
7	99-3433	1	Wire-Center
8	104-0405	1	Hose ASM
9	95-8821	1	Hose ASM
10	104-0406	1	Hose ASM
11	104-0416-03	1	Bracket-Slide
12	32128-43	4	Nut-Flange
13	104-0417	2	Slide-Plastic
14	3234-1	4	Screw-HHF
15	95-8531	2	Shaft-Pivot, Liftarm
16	32121-122	2	Pin-Roll
18	3234-27	2	Screw-Flange
19	325-38	8	Screw-HH
20	95-8609	8	Cap-Bearing
21	3218-5	4	Nut-Jam
22	325-6	2	Screw-HH
23	3296-23	8	Nut-Lock, NI

Ref	Part No.	Qty.	Description
24	87-7270	16	Washer-Thrust
25	99-3373	4	Bar-Support, Slide
26	95-8575	2	Pin
27	75-9590	2	Spacer-Cylinder
28	32120-93	4	Ring-Retaining
29	340-74	4	Locknut-Bulkhead
30	99-3640	1	Tube ASM
31	340-78	1	Locknut-Bulkhead
32	104-0469-03	1	Bracket-Latch, Transport
34	32128-43	2	Nut-Flange
37	104-0481	1	Liftarm ASM-68", RH
38	104-0482	1	Liftarm ASM-68", LH
39	323-6	2	Screw-HH
40	95-8979	2	Shaft
41	3-6781	2	Washer-Thrust
42	283-71	2	Pin-Lynch
43	104-0472	1	Rod
44	323-15	2	Screw-HH
48	3290-467	2	Pin-Hair
49	104-4639-03	1	Stop-Deck, LH
50	104-4640-03	1	Stop-Deck, RH
51	3269-11	4	Rivet
52	86-5350	2	Bumper-Rubber
53	32128-43	4	Nut-Flange

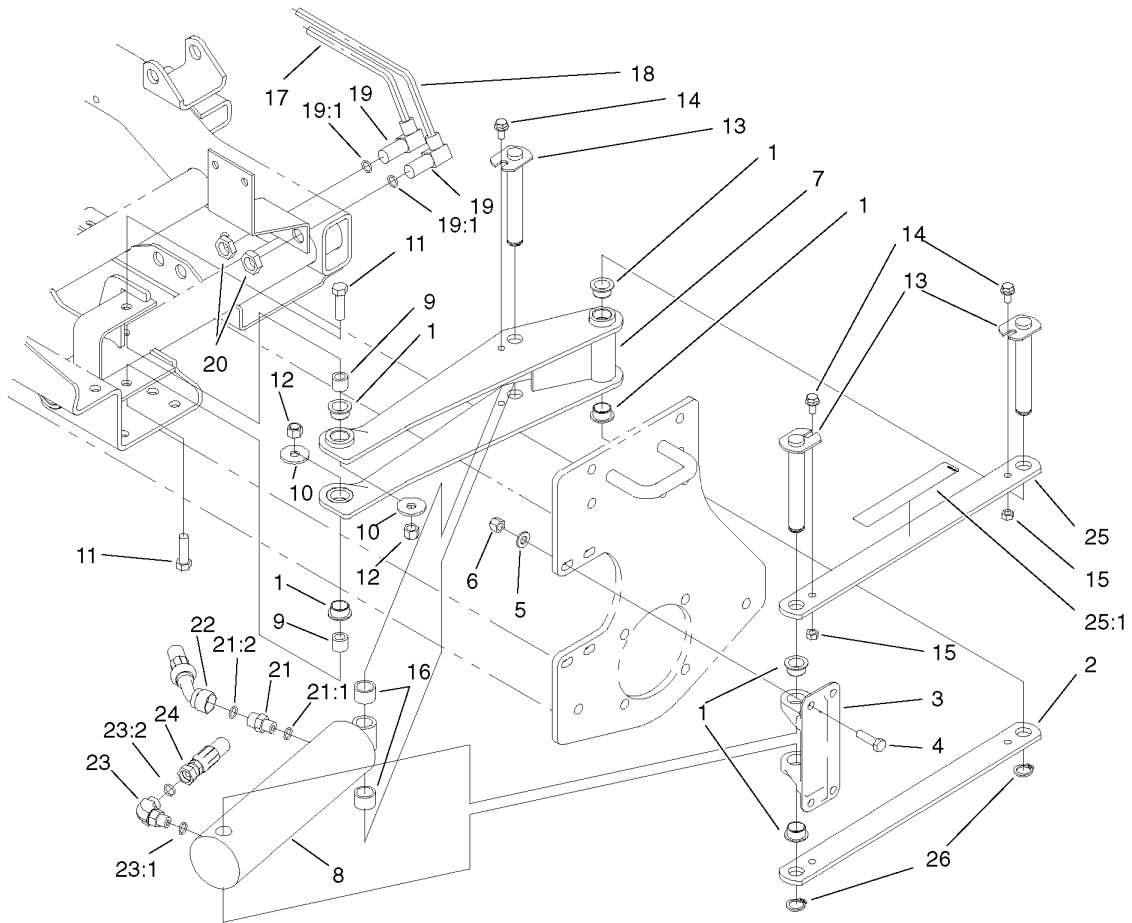

Scissor Assembly

Ref	Part No.	Qty.	Description
1	95-8526	6	Bushing-Plastic
2	95-8527-03	1	Link-Scissor
3	95-8883	1	Mount-Scissor
4	323-7	4	Screw-HH
5	3256-24	4	Washer-Flat
6	3296-39	4	Nut-Lock, NI
7	95-8521-03	1	Frame-Scissor
8	95-8512	1	Cylinder-Hydraulic
9	95-8603	2	Spacer
10	87-5330	2	Washer
11	324-6	2	Screw-HH
12	3296-48	2	Nut-Lock NI
13	95-8529	3	Pin
14	3234-14	3	Screw-HHF
15	32152-1	3	Nut-Lock, NI
16	46-6350	2	Spacer
17	95-8790	1	Tube ASM
18	95-8791	1	Tube ASM
19	340-154	2	Union-Bulkhead
19:1	237-22	2	O-Ring
20	340-70	2	Locknut-Bulkhead
21	85-9720	1	Fitting-Orificed
21:1	237-78	1	O-Ring
21:2	237-21	1	O-Ring

Ref	Part No.	Qty.	Description
22	95-8838	1	Hose ASM
23	340-132	1	Elbow-90Ø
23:1	237-78	1	O-Ring
23:2	237-21	1	O-Ring
24	95-8839	1	Hose ASM
25	99-3505	1	Link ASM-Scissors
25:1	94-3353	1	Decal-Point, Pinch
26	32120-93	2	Ring-Retaining

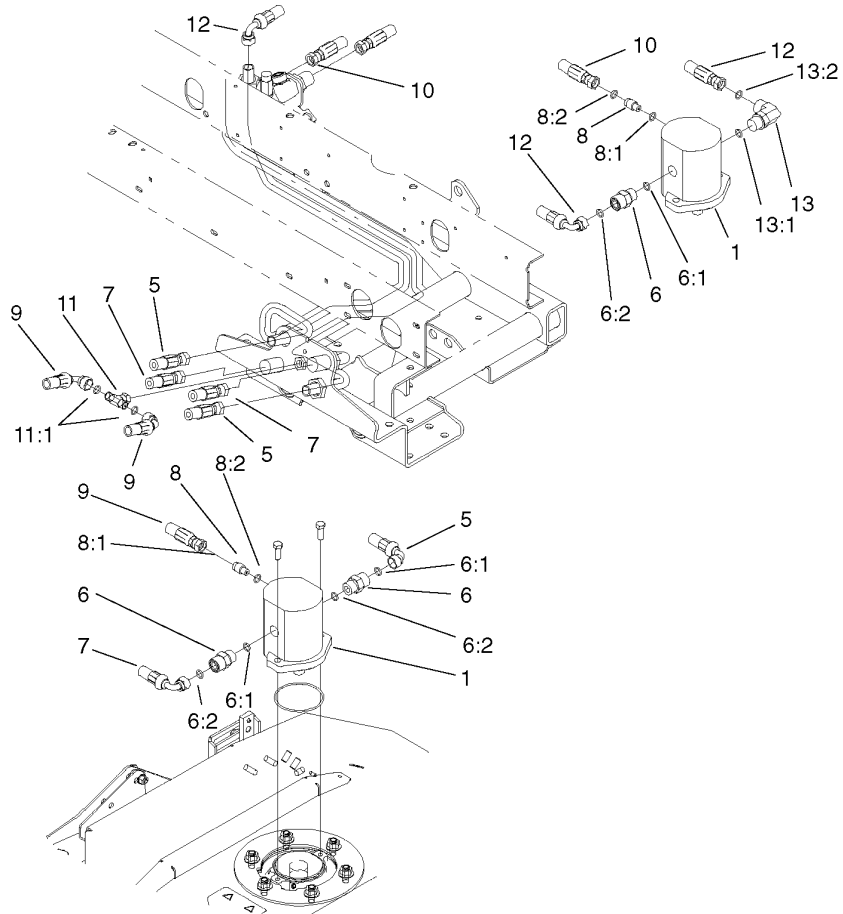

Reel Motor Assembly

Ref	Part No.	Qty.	Description
1	99-6104	3	Motor-Hydraulic
②*1:2	99-6105	1	Kit-Seal
②*1:3	98-5185	1	Bit-Flange/Valve, Back
②*1:4	98-5191	1	Kit-Valve, Relief
5	100-4882	2	Hose ASM
6	340-7	5	Adapter
6:1	237-65	1	O-Ring
6:2	237-80	1	O-Ring
7	100-4883	2	Hose ASM
8	340-92	3	Fitting
8:1	237-78	1	O-Ring
8:2	237-21	1	O-Ring
9	104-1080	2	Hose ASM
10	100-4876	1	Hose ASM
11	99-3477	1	Fitting-Tee
11:1	237-42	2	O-Ring
12	100-4880	2	Hose ASM
13	340-17	1	Adapter
13:1	237-65	1	O-Ring
13:2	237-80	1	O-Ring

--	--	--	--

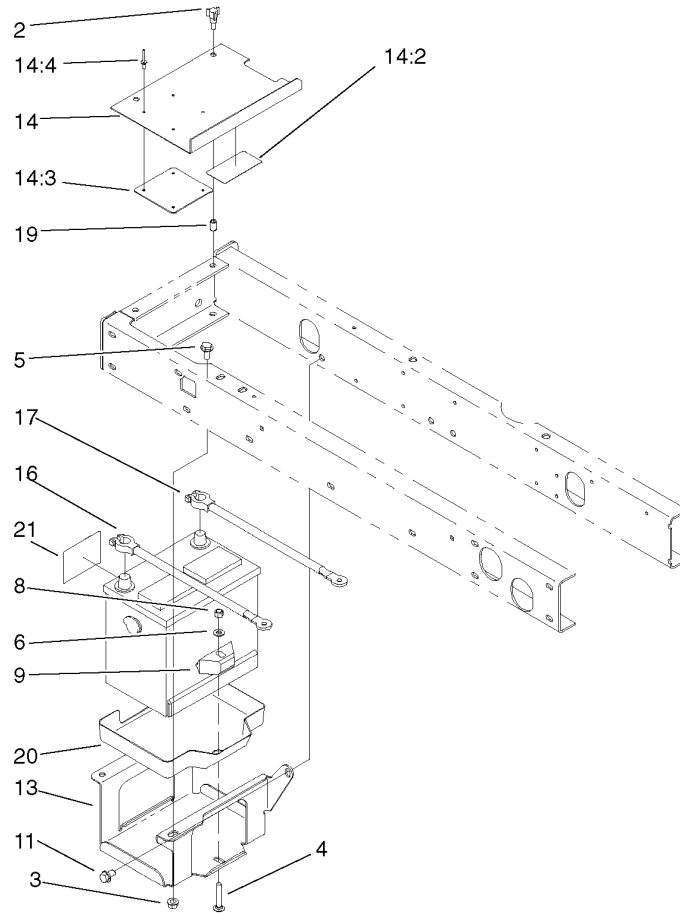

Battery Assembly

Ref	Part No.	Qty.	Description				
2	233-70	2	Knob-3 Star				
3	32128-43	3	Nut-Flange				
4	3230-6	1	Screw-CARR				
5	3234-1	3	Screw-HHF				
6	3256-23	1	Washer-Flat				
8	3296-29	1	Nut-Lock				
9	66-2490	1	Retainer-Battery				
11	32144-15	1	Screw				
13	95-8796-03	1	Support-Battery				
14	99-3602	1	Cover-Battery				
14:2	93-7276	1	Decal-Danger				
14:3	87-7620	1	Shield-Terminal, Battery				
14:4	3269-27	4	Rivet-Snap				
16	95-8853	1	Cable-Battery, Positive				
17	95-8854	1	Cable-Battery, Negative				
19	32148-6	2	Nut-Insert				
20	99-3513	1	Tray-Battery				
21	93-6668	1	Decal-Battery				

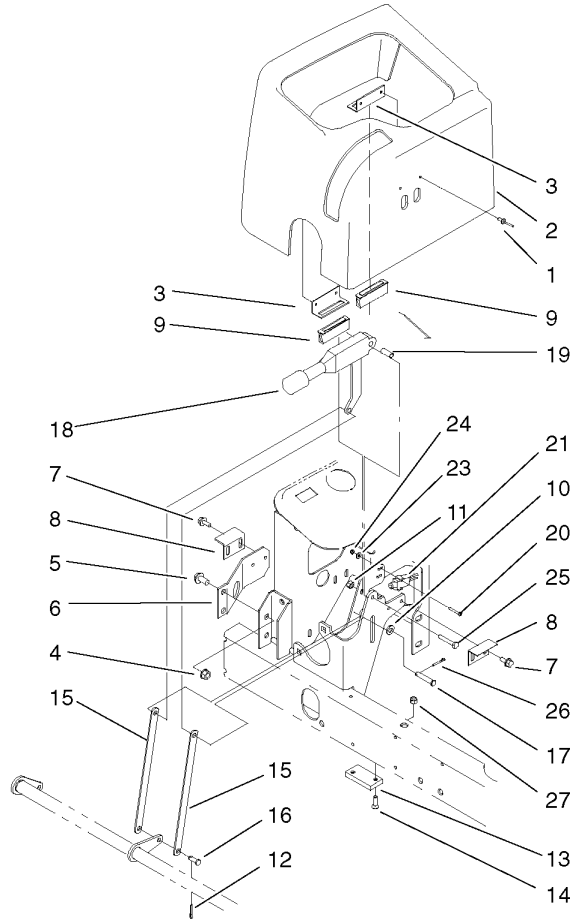

Parking Brake Assembly

Ref	Part No.	Qty.	Description
1	3269-5	4	Rivet
2	95-8707	1	Cover-Dash
3	95-8763	2	Bracket-Hold Down, Cover
4	32128-43	2	Nut-Flange
5	3234-1	2	Screw-HHF
6	95-8764-03	1	Support-Magnet
7	32144-10	4	Screw-HWH
8	95-8765	2	Bracket-Strike, Magnet
9	58-4250	2	Catch-Magnetic
10	3256-23	1	Washer-Flat
11	3296-42	1	Nut-Lock
12	3272-10	1	Pin-Cotter
13	95-8684	1	Pad-Bumper
14	3289-4	2	Screw-FH
15	104-4628-03	2	Link-Brake, Parking
16	283-62	1	Pin-Clevis
17	94-3829	1	Pin-Clevis
18	104-4817	1	Lever-Brake
19	87-4710	1	Spacer-Brake, Parking
20	32105-9	2	Screw
21	95-8900	1	Switch
23	3256-21	2	Washer-Flat
24	3296-9	2	Nut-Lock NI
25	321-9	1	Screw-HH

Ref	Part No.	Qty.	Description
26	3272-6	1	Pin-Cotter
27	32128-32	2	Nut-HHF

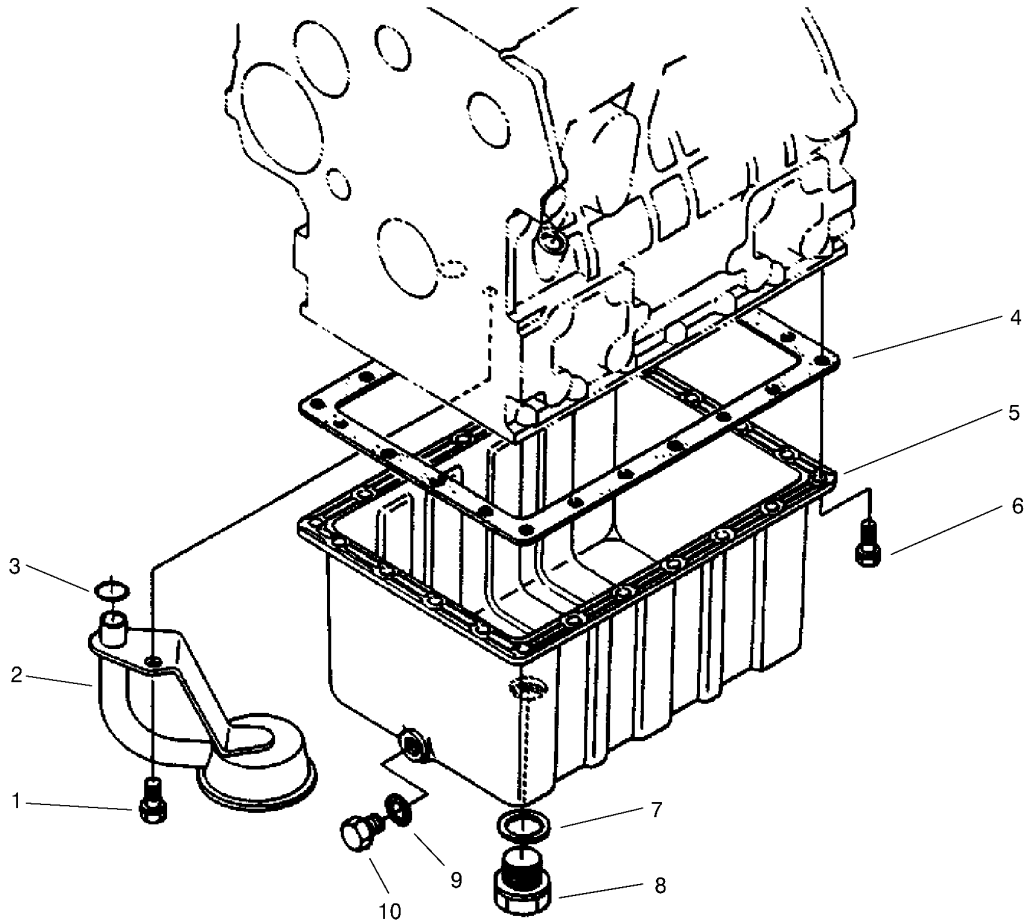

Oil Pan Assembly

Ref	Part No.	Qty.	Description				
1	98-9358	1	Bolt				
2	98-9538	1	Filter-Oil				
3	98-7527	1	O-Ring				
4	98-9646	1	Gasket-Pan, Oil				
5	98-9685	1	Drain-Oil				
6	98-9350	22	Bolt				
7	98-9399	1	Gasket				
8	98-7523	1	Plug-Drain				
9	98-7524	1	Gasket				
10	98-9386	1	Plug				

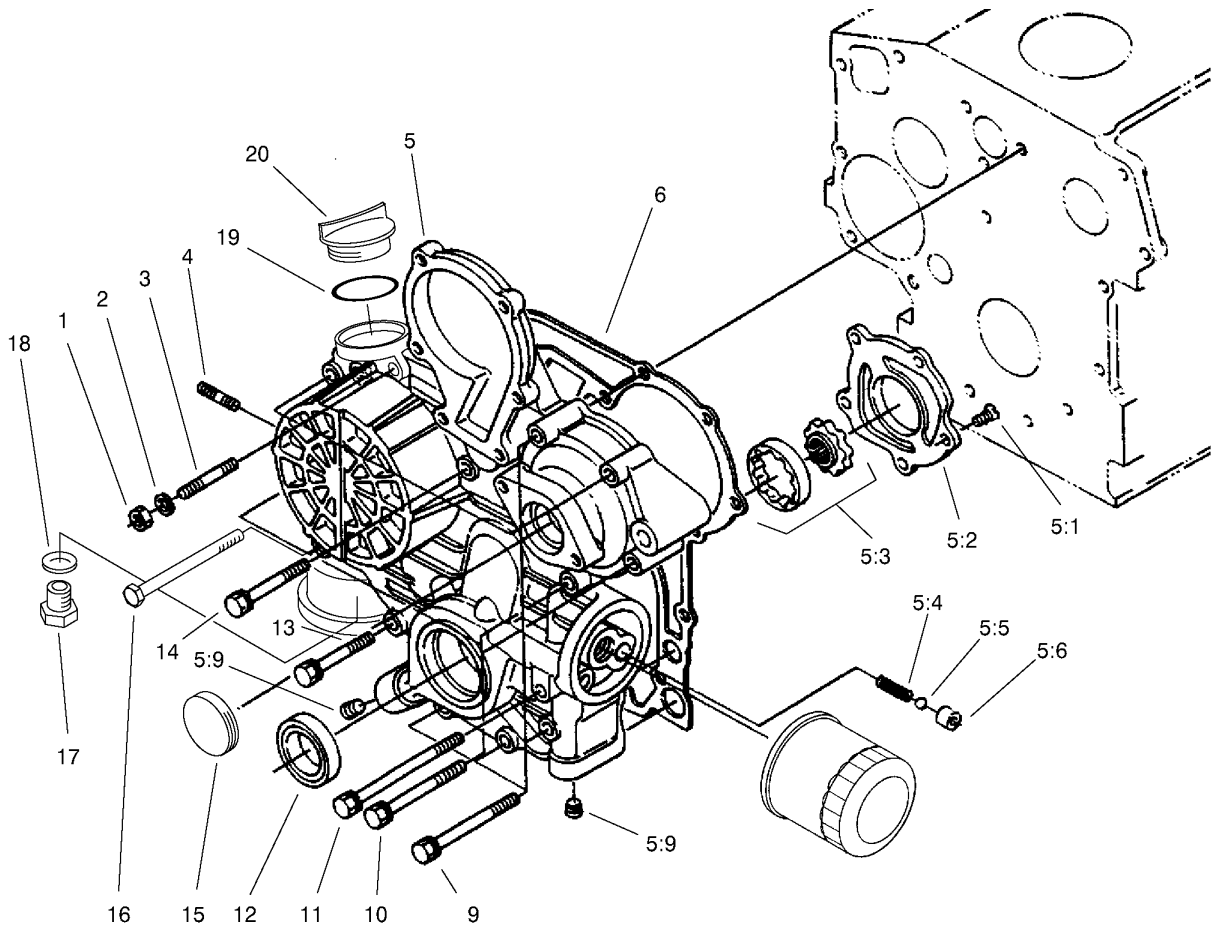

Grease And Oil Filter Assembly

Ref	Part No.	Qty.	Description
1	98-7572	1	Nut
2	98-9367	1	Washer-Spring
3	98-9363	1	Stud
4	98-9362	2	Stud
5	99-3462	1	Gear Case ASM
5:1	98-9592	5	Screw
5:2	98-9541	1	Cover-Pump, Oil
5:3	98-9540	1	Oil Pump Rotor ASM
5:4	98-9544	1	Spring
5:5	98-9380	1	Ball
5:6	98-9543	1	Seat-Valve
5:9	98-9598	2	Plug
6	98-9633	1	Gasket-Case, Gear
7	98-9372	2	O-Ring
8	98-7547	2	O-Ring
9	98-9356	2	Bolt
10	98-9355	6	Bolt
11	99-3510	2	Bolt
12	98-9482	1	Seal-Oil
13	98-9437	1	Bolt
14	98-7496	3	Bolt
15	99-3515	1	Plug-Gearcase
16	99-3511	1	Bolt
17	99-3450	2	Plug

Ref	Part No.	Qty.	Description
18	99-3451	1	Plug-Packing
19	98-7430	1	O-Ring
20	98-9449	1	Plug-Filler, Oil

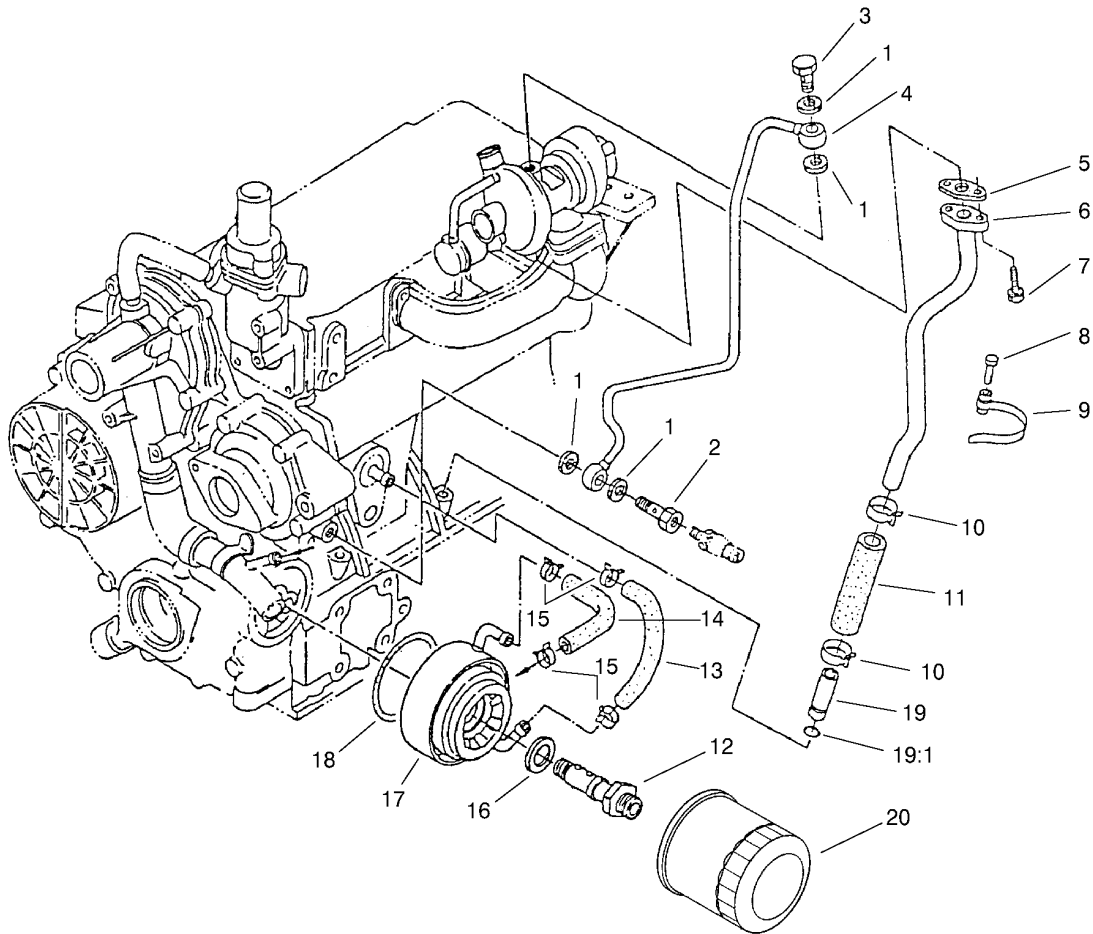

Filter, Oil Cooler, And Pipe Assembly

Ref	Part No.	Qty.	Description
1	99-8346	4	Gasket
2	98-9417	1	Bolt-Joint, Eye
3	98-9418	1	Bolt-Joint, Eye
4	98-9419	1	Oil Pipe ASM
5	98-9435	1	Gasket-Oil Return, Turbo
6	98-9461	1	Pipe Line ASM
7	98-7568	2	Bolt
8	98-9591	1	Pin-Band
9	98-9601	1	Clamp-Pipe
10	98-9714	2	Clamp-Hose
11	98-9721	1	Pipe-Oil
12	98-9723	1	Holder ASM
13	98-9724	1	Pipe-Cooler, Oil
14	98-9578	1	Pipe-Return, Water
15	98-9579	4	Band-Pipe
16	98-9727	1	Collar
17	98-9728	1	Oil Cooler ASM
18	98-9729	1	O-Ring
19	99-8383	1	Oil Pipe ASM
19:1	98-9722	1	O-Ring
20	99-8384	1	Filter-Oil

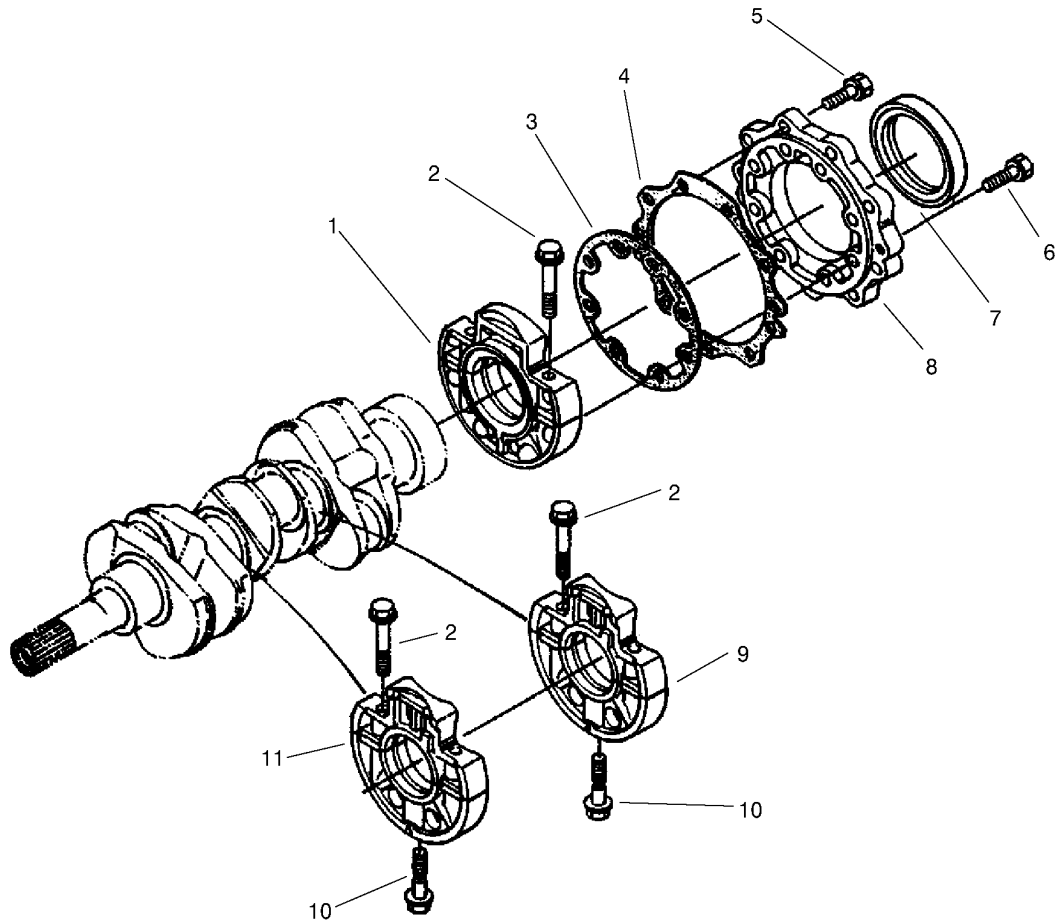

Main Bearing Case Assembly

Ref	Part No.	Qty.	Description
1	98-9480	1	Main Bearing Case ASM
2	98-9484	6	Bolt-Case, Bearing
3	98-9634	1	Gasket-Case, Bearing
4	98-9635	1	Gasket-Cover, Bearing Case
5	98-7568	9	Bolt
6	98-9352	8	Bolt
7	98-9483	1	Seal-Oil
8	98-9487	1	Cover-Case, Bearing
9	99-8360	1	Case-Bearing, Main
10	98-9485	2	Bolt-Case, Bearing
11	99-8361	1	Case-Bearing, Main

--	--	--	--

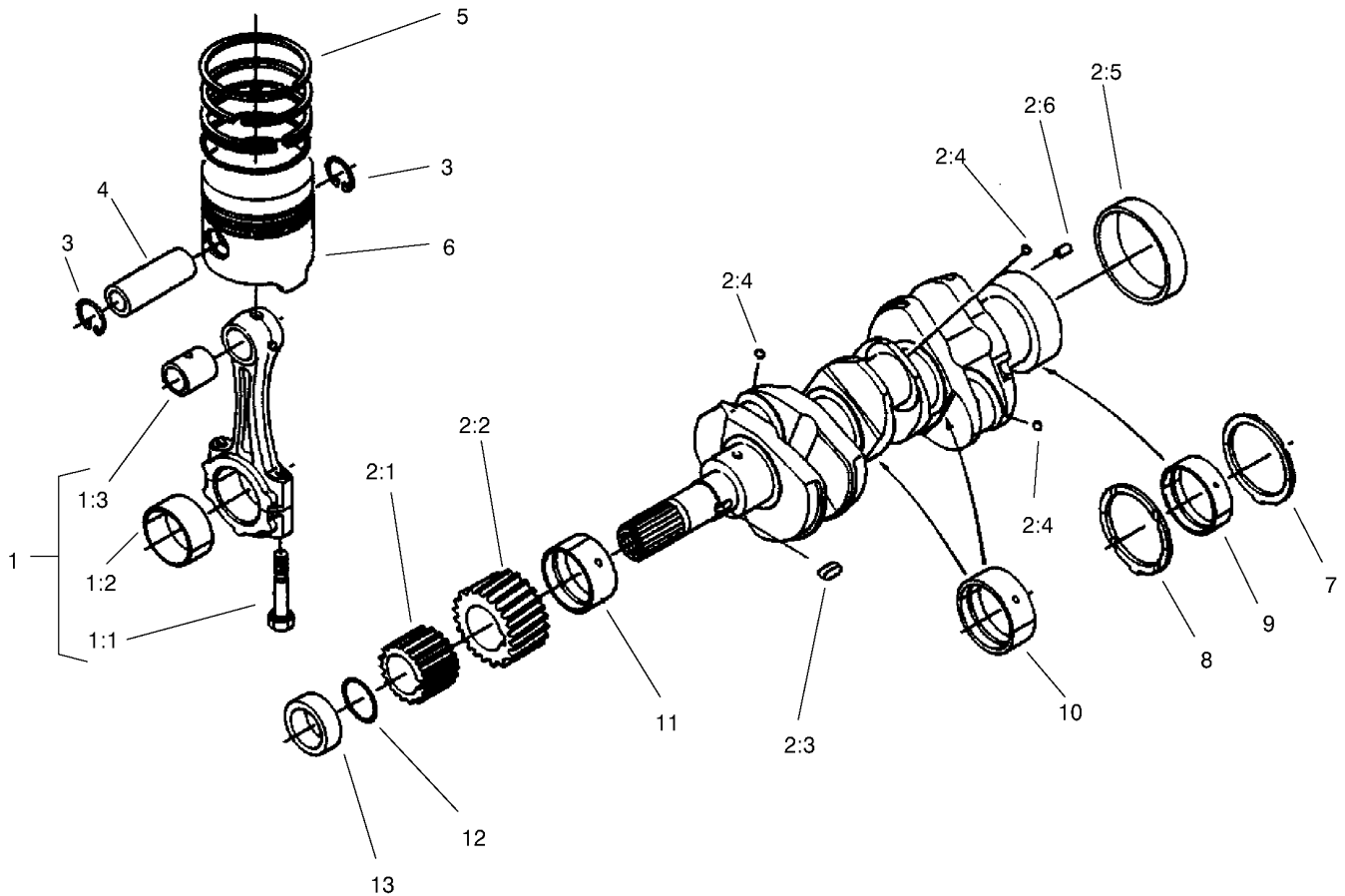

Piston And Crankshaft Assembly

Ref	Part No.	Qty.	Description
1	98-9552	3	Connecting Rod ASM
1:1	98-9517	6	Bolt-Rod, Connecting
1:2	98-9519	3	Bearing-Rod (-0.2Mm)
1:2	98-9520	3	Bearing-Rod (-0.4Mm)
1:2	98-9553	3	Bearing-Rod (STD)
1:3	98-9515	3	Bushing-Pin, Piston
2	98-9642	1	Crankshaft ASM
2:1	98-9542	1	Gear-Drive, Oil Pump
2:2	98-9532	1	Gear-Crankshaft
2:3	98-9666	1	Key
2:4	98-7473	3	Ball
2:5	98-9522	1	Sleeve-Crankshaft
2:6	98-9375	1	Pin-Straight
3	98-9514	6	Clip-Circular, Piston Pin
4	98-9513	3	Pin-Piston
5	98-9551	3	Piston Ring ASM (STD)
5	98-9619	3	Piston Ring ASM (+0.5Mm)
6	98-9470	3	Piston (+0.5Mm)
6	98-9550	3	Piston-STD
7	98-9413	2	Bearing-Thrust (STD)
7	98-9414	2	Bearing-Thrust (+0.2Mm)
7	98-9415	2	Bearing-Thrust (+0.4Mm)
8	98-9688	2	Bearing-Thrust (STD)
8	98-9689	2	Bearing-Thrust (+0.2Mm)

Ref	Part No.	Qty.	Description
8	98-9690	2	Bearing-Thrust (+0.4Mm)
9	98-9526	1	Bearing-Main (-0.2Mm)
9	98-9527	1	Bearing-Main (-0.4Mm)
9	98-9556	1	Bearing-Main (STD)
10	98-9530	2	Bearing-Main (-0.2Mm)
10	98-9531	2	Bearing-Main (-0.4Mm)
10	98-9555	2	Bearing-Main (STD)
11	98-9528	1	Bearing-Main (-0.2Mm)
11	98-9529	1	Bearing-Main (-0.4Mm)
11	98-9554	1	Bearing-Main (STD)
12	98-9373	1	O-Ring
13	98-9521	1	Collar-Crankshaft

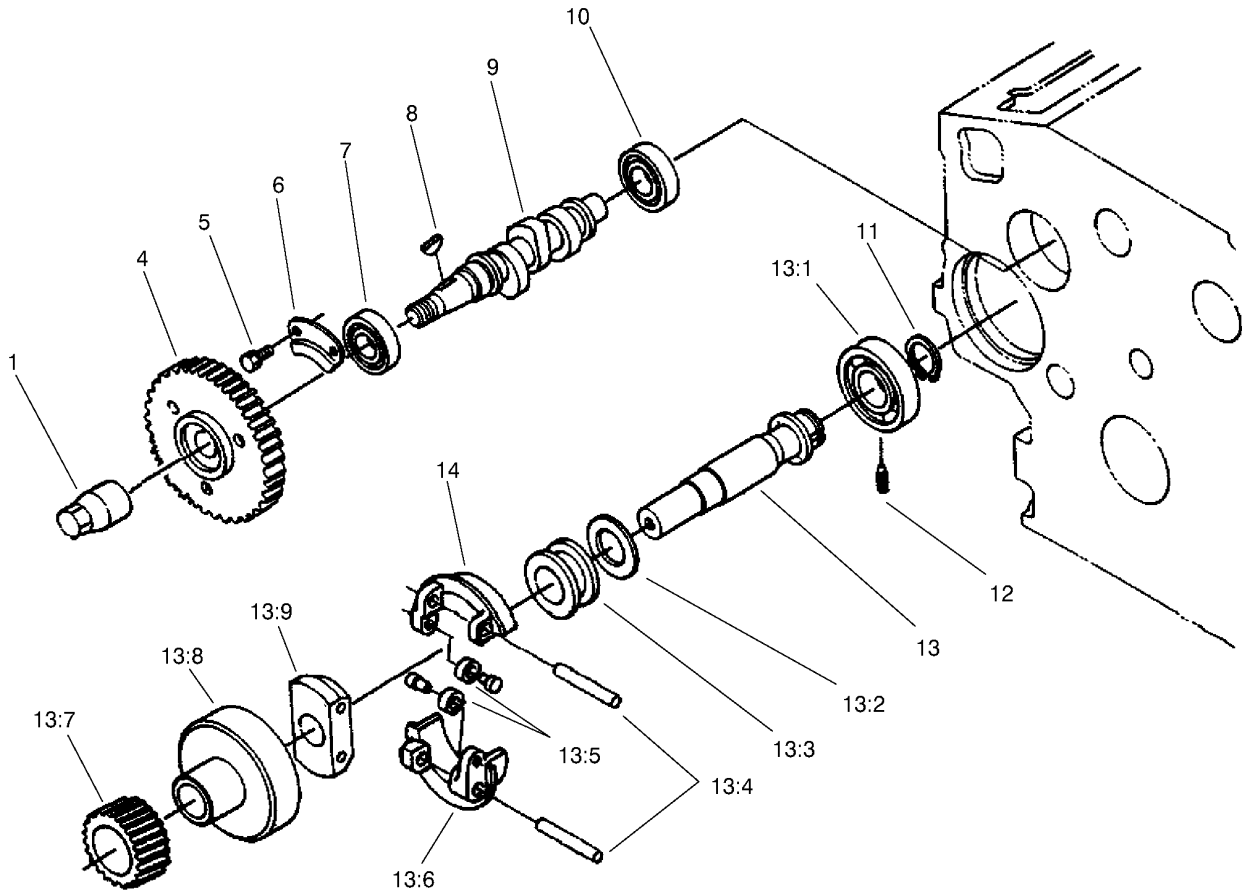

Fuel Camshaft Assembly

Ref	Part No.	Qty.	Description
1	98-9590	1	Nut-Cap
4	98-9669	1	Gear-Pump, Injection
5	98-9350	2	Bolt
6	98-9511	1	Stopper-Fuel, Camshaft
7	98-9383	1	Bearing-Ball
8	98-9595	1	Key-Woodruff
9	98-9459	1	Camshaft-Fuel
10	98-9382	1	Bearing-Ball
11	98-9657	1	Clip-Circular, Governor Shaft
12	98-9565	1	Screw-Set
13	98-9644	1	Governor Shaft ASM
13:1	98-9381	1	Bearing-Ball
13:2	98-9564	1	Washer-Thrust
13:3	98-9563	1	Sleeve-Governor
13:4	98-9560	2	Shaft-Weight, Governor
13:5	98-9692	2	Roller
13:6	98-9559	2	Governor Weight ASM
13:7	98-9673	1	Gear-Governor
13:8	98-9562	1	Holder-Gear, Governor
13:9	98-9561	1	Holder-Weight, Governor
14	98-9559	2	Governor Weight ASM

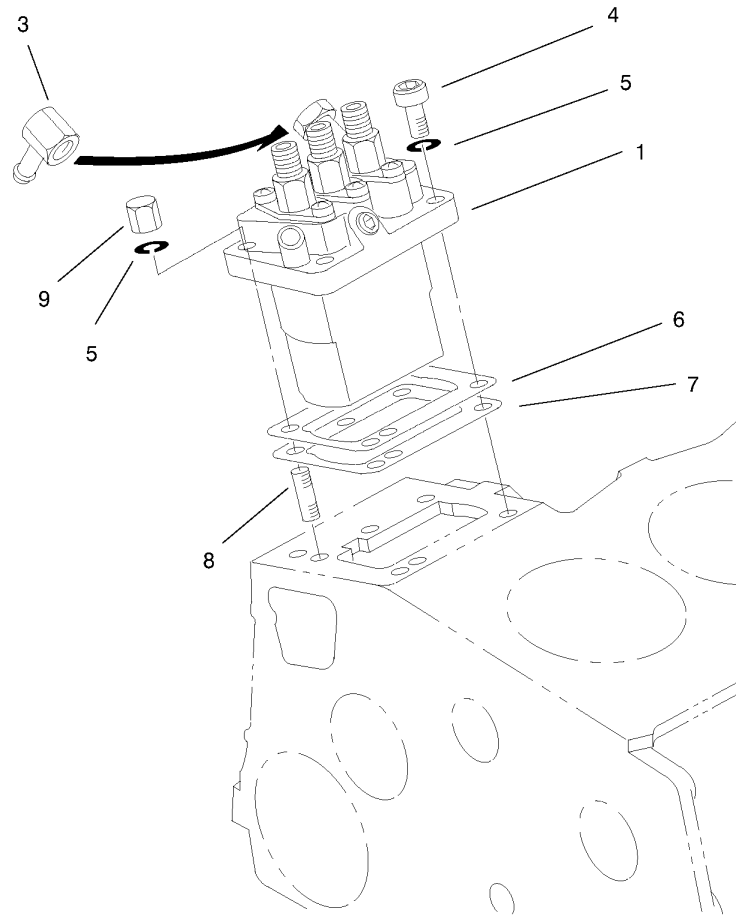

Injection Pump Installation Assembly

Ref	Part No.	Qty.	Description	
1	98-9643	1	Injection Pump ASM	
3	98-9596	1	Joint-Eye	
4	98-9361	2	Bolt-HSH	
5	98-9367	4	Washer-Spring	
6	98-9456	1	Shim-Injection (0.20Mm)	
6	98-9457	1	Shim-Injection (0.25Mm)	
7	98-9458	1	Shim-Injection (0.30Mm)	
8	98-9438	2	Stud	
9	98-9440	2	Nut-Cap	

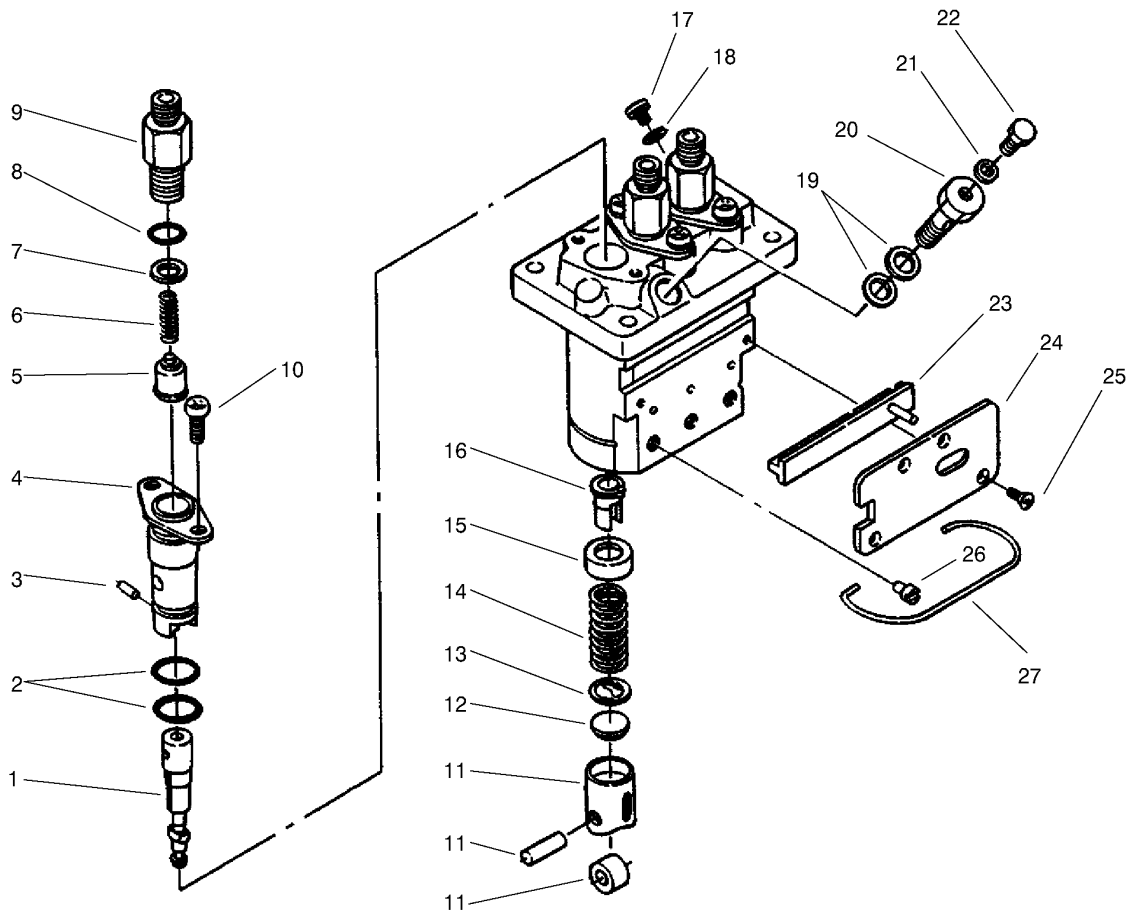

Injection Pump Assembly No. 98-9643

Ref	Part No.	Qty.	Description
1	98-9462	3	Element-Pump
2	98-9423	6	O-Ring
3	98-9443	3	Pin-Joint
4	98-9434	3	Flange-Sleeve
5	98-9421	3	Valve-Delivery
6	98-9424	3	Spring-Valve, Delivery
7	98-9425	3	Gasket-Valve, Delivery
8	98-9447	3	O-Ring
9	98-9652	3	Holder-Valve, Delivery
10	98-9452	6	Screw
11	98-9422	3	Tappet ASM
12	98-9433	3	Shim
13	98-9429	3	Seat-Spring, Lower
14	98-9428	3	Spring-Plunger
15	98-9427	3	Seat-Spring, Upper
16	98-9432	3	Sleeve-Control
17	98-9466	1	Plug
18	98-9451	1	Gasket
19	98-9445	1	Gasket
20	98-9464	1	Bolt-Joint
21	98-9446	1	Gasket
22	98-9430	1	Screw
23	98-9463	1	Control-Rack
24	98-9465	1	Plate

Ref	Part No.	Qty.	Description
25	98-9442	4	Screw
26	98-9426	3	Pin-Guide, Tappet
27	98-9450	1	Pin-Clamp

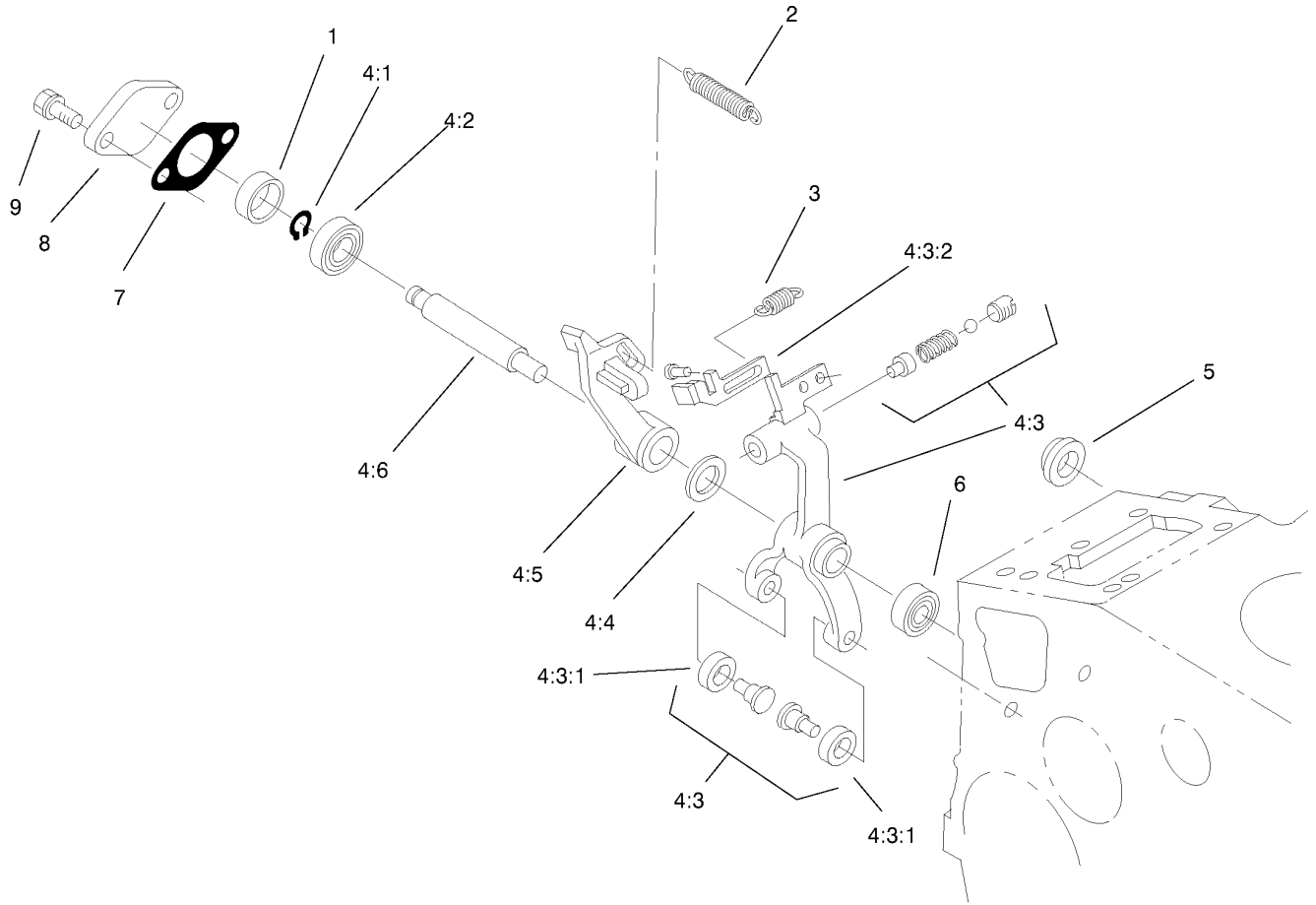

Governor Assembly

Ref	Part No.	Qty.	Description
1	98-9567	1	Collar
2	98-9681	1	Spring-Governor
3	98-9645	1	Spring-Start
4	98-9680	1	Fork Lever ASM
4:1	98-9369	1	Clip-Circular, External
4:2	98-9570	1	Bearing-Miniaturize
4:3	99-8380	1	Fork Lever ASM
4:3:1	98-9692	2	Roller
4:3:2	98-9660	1	Lever-Thrust
4:4	98-9593	1	Washer-Plain
4:5	98-9659	1	Lever-Fork
4:6	98-9566	1	Shaft-Lever, Fork
5	98-9568	1	Collar
6	98-9571	1	Bearing-Miniaturize
7	98-9682	1	Gasket
8	98-9569	1	Cover-Shaft, Fork Lever
9	98-9351	2	Bolt

--	--	--	--

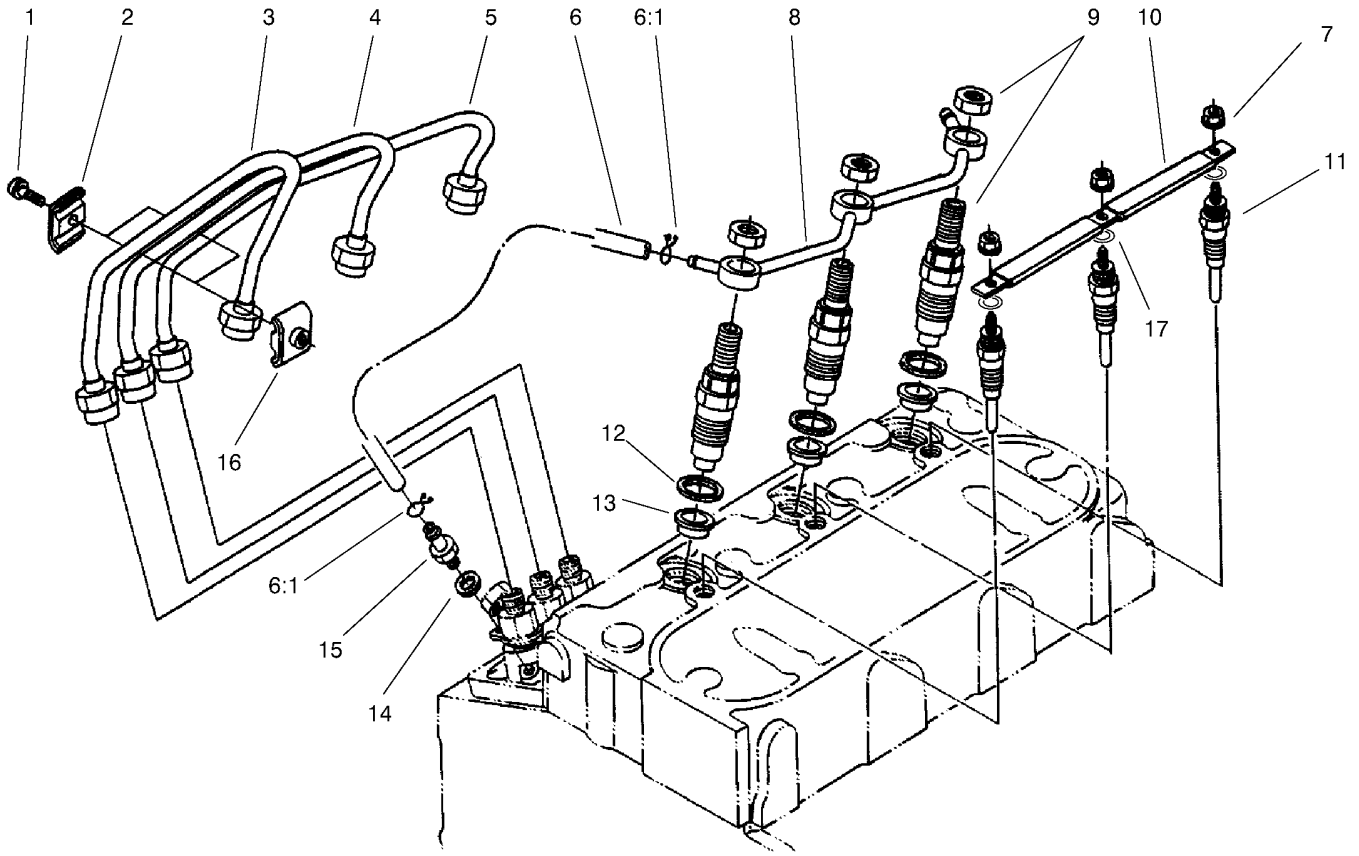

Nozzle Holder And Glow Plug Assembly

Ref	Part No.	Qty.	Description
1	98-7684	2	Screw W/Washer
2	98-7683	2	Clamp-Pipe
3	98-9622	1	Pipe Injection
4	98-9654	1	Pipe-Injection
5	98-9655	1	Pipe-Injection
6	98-9624	1	Overflow Pipe ASM
6:1	98-7671	2	Clip-Pipe
7	99-8377	3	Nut-Flange
8	98-9621	1	Overflow Pipe ASM
9	98-9468	3	Nozzle Holder ASM
10	98-9631	1	Cord-Plug, Glow
11	98-9623	3	Plug-Glow
12	98-7676	3	Gasket
13	98-7677	3	Seal
14	98-7654	1	Gasket
15	98-9431	1	Screw-Bleeder
16	98-7682	2	Clamp-Pipe
17	99-8378	3	Washer-Plain

--	--	--	--

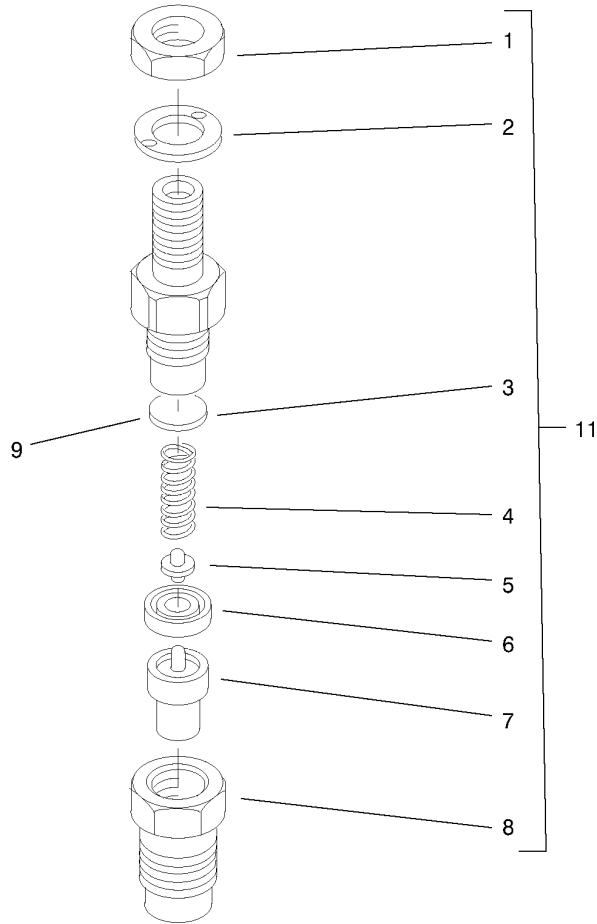

Nozzle Holder Assembly No. 98-9468

Ref	Part No.	Qty.	Description
1	99-8301	3	Nut
2	99-8307	3	Washer-Plain
3	99-8302	3	Washer-Adjusting
4	99-8303	3	Spring-Nozzle
5	99-8305	3	Rod-Push
6	99-8304	3	Spacer-Distance
7	99-8308	3	Piece-Nozzle
8	99-8306	3	Nut-Nozzle
9	99-8313	3	Washer-Adjust (0.40 Mm)
9	99-8314	3	Washer-Adjust (0.50 Mm)
9	99-8315	3	Washer-Adjust (0.52 Mm)
9	99-8316	3	Washer-Adjust (0.54 Mm)
9	99-8317	3	Washer-Adjust (0.56 Mm)
9	99-8312	3	Washer-Adjust (0.30 Mm)
9	99-8319	3	Washer-Adjust (0.80 Mm)
9	99-8318	3	Washer-Adjust (0.58 Mm)
9	99-8309	3	Adjusting Washer ASM
9	99-8310	3	Washer-Adjust (0.10 Mm)
9	99-8311	3	Washer-Adjust (0.20 Mm)

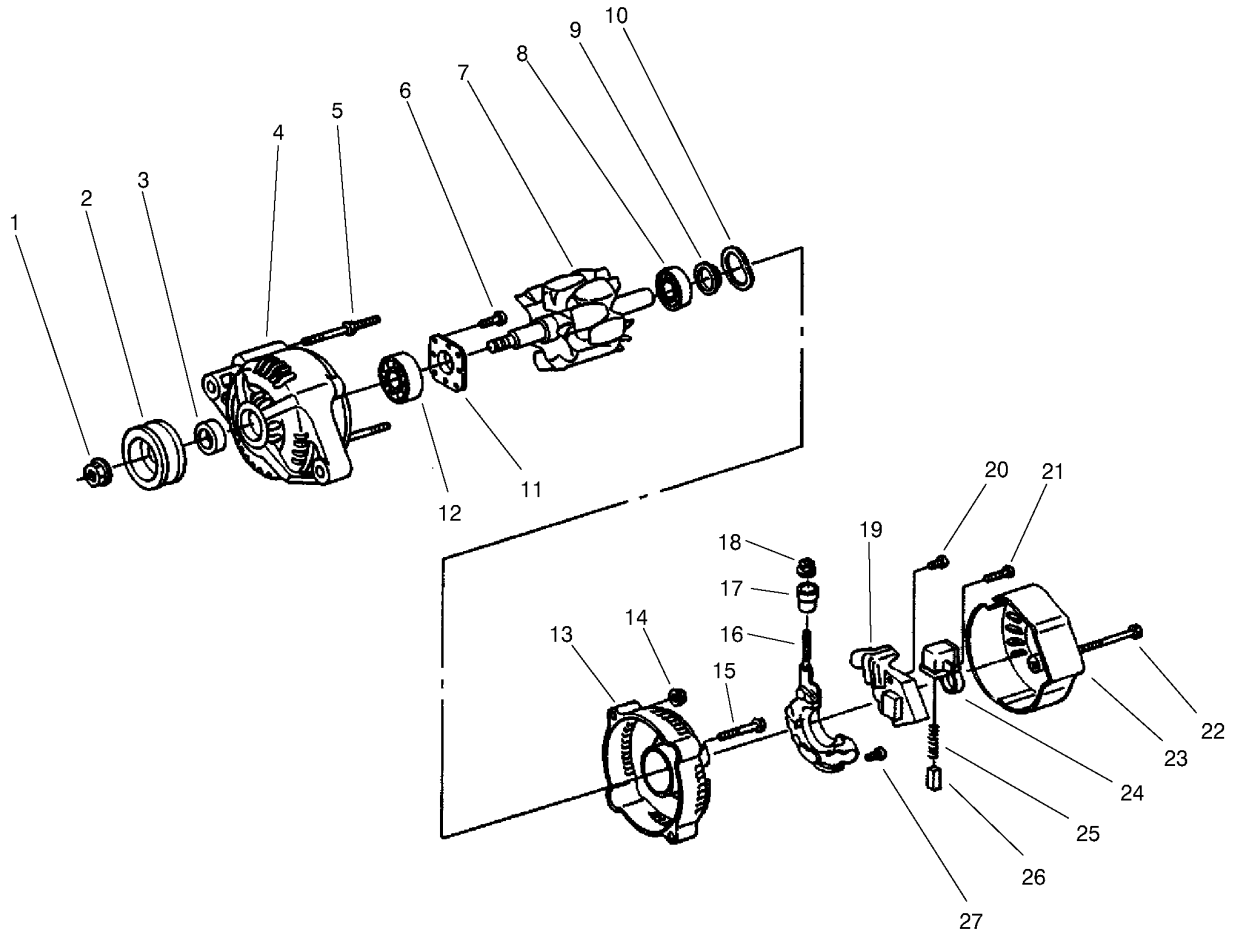

Alternator Assembly No. 98-9474

Ref	Part No.	Qty.	Description
1	98-7708	1	Nut
2	98-9453	1	Pulley-Dynamo
3	98-7709	1	Collar
4	98-7714	1	Frame-End, Drive
5	98-7717	2	Bolt-Through
6	98-7716	4	Screw-Head, Round
7	98-7710	1	Rotor
8	98-7712	1	Bearing-Ball
9	98-7711	1	Cover-Bearing
10	98-7713	1	Washer-Thrust
11	98-7715	1	Plate-Retainer
12	98-7718	1	Bearing-Ball
13	98-7719	1	Frame-End
14	98-7730	2	Nut
15	98-7731	2	Bolt
16	98-7721	1	Rectifier ASM
17	98-7722	1	Bushing-Insulation
18	98-7732	1	Nut
19	98-7733	1	Regulator ASM
20	98-7726	2	Screw-Head, Round
21	98-7728	1	Screw-Head, Round
22	98-7729	3	Bolt
23	98-7720	1	Cover-End
24	98-7723	1	Holder-Brush

Ref	Part No.	Qty.	Description
25	98-7725	2	Spring-Brush
26	98-7724	2	Brush
27	98-7727	6	Screw-Head, Round

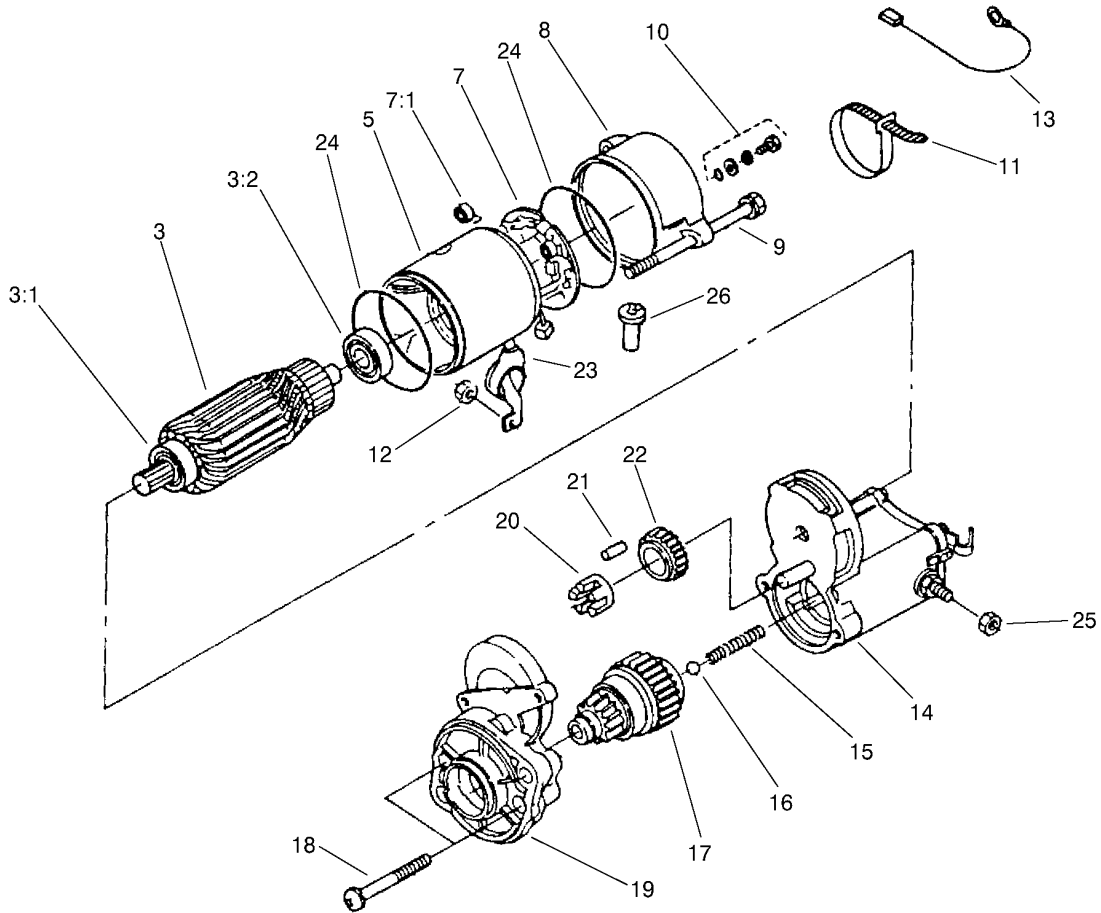

Starter Assembly No. 98-9705

Ref	Part No.	Qty.	Description
3	98-7742	1	Armature ASM
3:1	98-7743	1	Bearing
3:2	98-7744	1	Bearing
5	98-7741	1	Yoke ASM
7	98-7749	1	Brush Holder ASM
7:1	98-7750	4	Spring-Brush
8	99-8370	1	Frame-End
9	98-9549	2	Bolt
10	98-7758	2	Bolt ASM
11	98-9712	1	Band-Cover
12	99-8371	1	Nut-Hex
13	98-9711	1	Cord-Solenoid, Stop
14	99-8372	1	Magnetic Switch ASM
15	98-7754	1	Spring
16	98-7755	1	Ball
17	99-8373	1	Clutch-Running, Over
18	98-7756	2	Bolt
19	99-8374	1	Frame-End, Drive
20	98-7752	1	Retainer
21	98-7753	5	Roller
22	98-7751	1	Gear
23	99-8375	1	Cover
24	98-7757	2	O-Ring
25	99-8376	1	Nut-Hex

Ref	Part No.	Qty.	Description
26	98-7759	1	Pipe-Drain

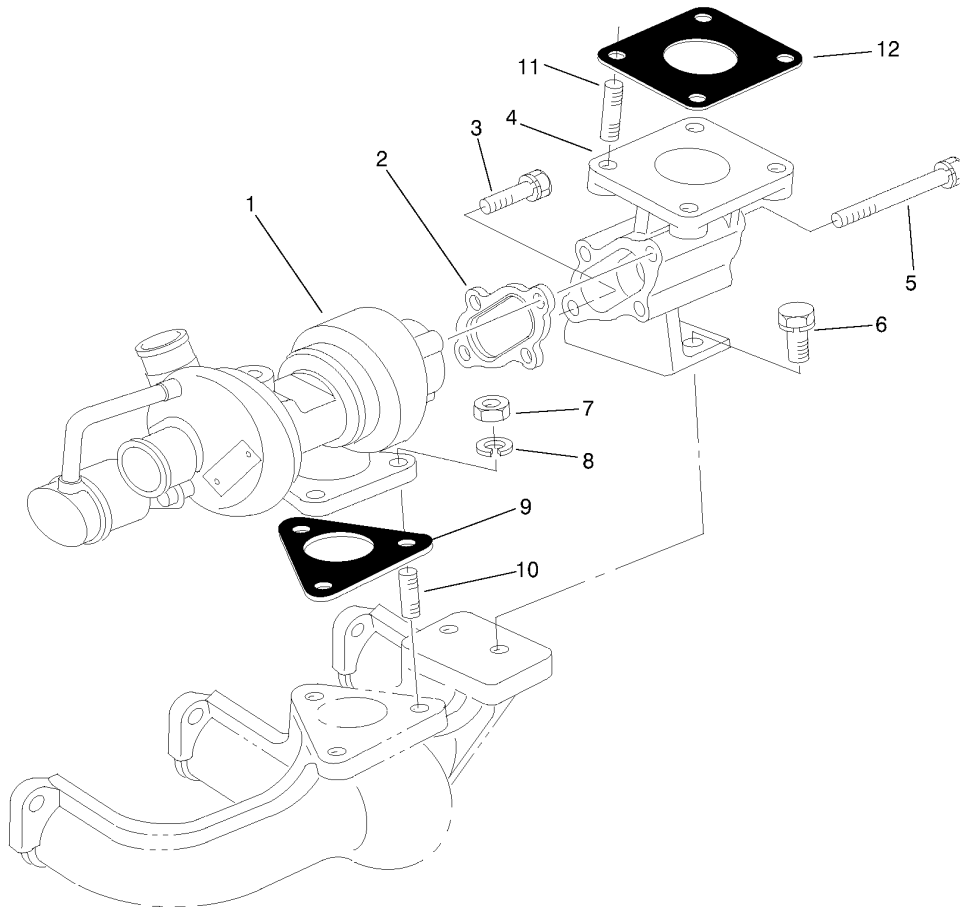

Turbo Charge Assembly

Ref	Part No.	Qty.	Description				
1	99-8332	1	Turbo Charger ASM				
2	99-8333	1	Gasket				
3	99-8334	1	Bolt				
4	99-8335	1	Flange-Muffler				
5	99-8336	3	Bolt				
6	98-7610	2	Bolt				
7	98-7534	3	Nut				
8	99-8339	3	Washer-Spring				
9	99-8340	1	Gasket				
10	99-8341	3	Stud				
11	99-8342	4	Stud				
12	99-8343	1	Gasket-Muffler				

NOTES

NOTES

