



Eurocycler 34cm Electric Lawn Mower

Model No. 21083 - 280G00001 and up.

Parts Catalog

Ordering Replacement Parts

To order replacement parts, please supply the part number, the quantity, and the description of each part desired.

Understanding Reference Numbers

Each identified part in an illustration has a reference number. The reference number for a part also appears in the parts list, along with other information about the part.

This catalog uses two special reference number formats, one to indicate parts in a service assembly and another to indicate the quantity of a given part in an illustration.

Service Assembly Reference Numbers

Parts in service assemblies have reference numbers in the form a:b. The a represents the reference number of the entire service assembly and the b represents a sequential number unique to each part within the service assembly.

For example, a wheel assembly might be identified by reference number 6, the tire by 6:1, the valve by 6:2, and the wheel by 6:3. When you order the assembly identified by reference number 6, you receive all parts identified by reference numbers 6:1, 6:2, and 6:3. However, you may also order any part individually. Reference numbers of this type appear in illustrations and in part lists.

Reference Numbers Indicating Quantity

In an illustration, if a reference number indicates more than one part, the reference number has the form nX y. The n represents the quantity of the part, the X is the multiplication symbol, and the y represents the reference number.

For example, in an illustration, the reference number 2X 37 means that two of the parts identified by reference number 37 are indicated.

Contents

Description	Page	Description	Page
Housing Assembly 3	Handle Assembly 6
Single Point Height-of-Cut Assembly 4	Bag Assembly 7
Motor and Blade Assembly 5	Attachments and Accessories List 8

Part Description Abbreviations

Part descriptions in this catalog may include the following abbreviations.

AR. as required	HYD. hydraulic
ASM. assembly	LH. left hand
BBC. blade brake clutch	NI. nylon insert
CARR. carriage	NPTF. national pipe thread fine
DEG. degrees	PFH. phillips flat head
EXT. external	PPH. phillips pan head
FH. flat head	PPHTF. phillips pan head thread forming
GA. gauge	PRH. phillips round head
HD. heavy-duty	PTH. phillips truss head
HF. hex flange	PTO. power-take-off
HH. hex head	RH. right hand
HHF. hex head flange	ROPS. roll-over protection system
HHFTF. hex head flange thread forming	SFH. slotted fillister head
HJ. hex jam	SHH. slotted hex head
HLH. hex lag head	SHWH. slotted hex washer head
HOC. height-of-cut	SPH. slotted pan head
HSBH. hex socket button head	SQH. square head
HSFH. hex socket flat head	SRH. slotted round head
HSH. hex socket head	STD. standard
HWH. hex washer head	TAP. self tapping
HWHTF. hex washer head thread forming	TTH. torx truss head

Footnotes

❶ Not illustrated

❷ Not serviced separately

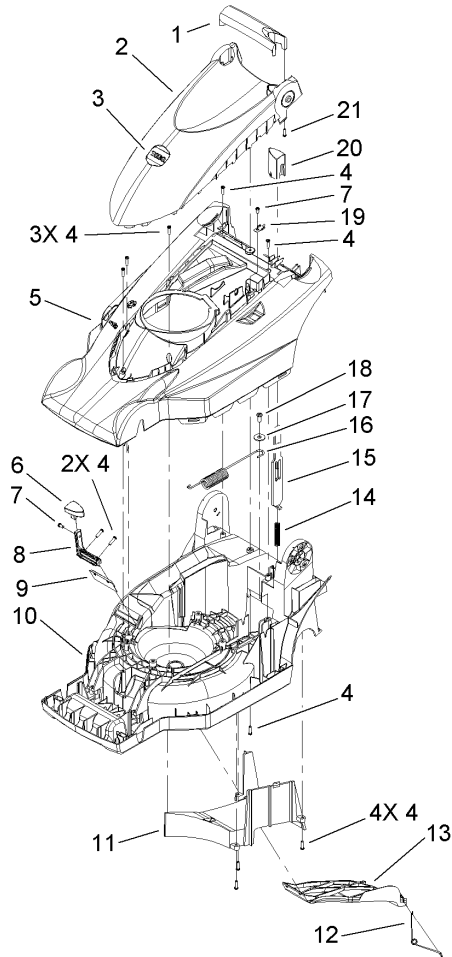

Housing Assembly

Ref	Part No.	Qty.	Description
1	110-1214	1	Handle-Lift
2	110-1213	1	Cover-Motor
3	110-1280	1	Decal
4	110-1271	12	Screw-Torx, Pan Head
5	110-1209	1	Deck-Upper
6	110-1131	1	Knob-Rod
7	110-1269	2	Screw-Torx, Pan Head
8	110-1104	1	Clamp-Door
9	110-8442	1	Shim-Clamp
10	110-1208	1	Deck-Lower
11	110-1224	1	Baffle-Chamber, Insert
12	110-1103	1	Spring-Torsion
13	110-1223	1	Door-Recycle
14	110-1117	1	Spring-Compression
15	110-1118	1	Plate-HOC
16	110-1119	1	Spring-Extension
17	110-8447	1	Washer-Din
18	110-1273	1	Screw-Torx, Pan Head
19	110-1132	1	Clamp-Cable
20	110-1116	1	Knob-HOC
21	110-8406	4	Screw-Torx, Pan Head

--	--	--	--

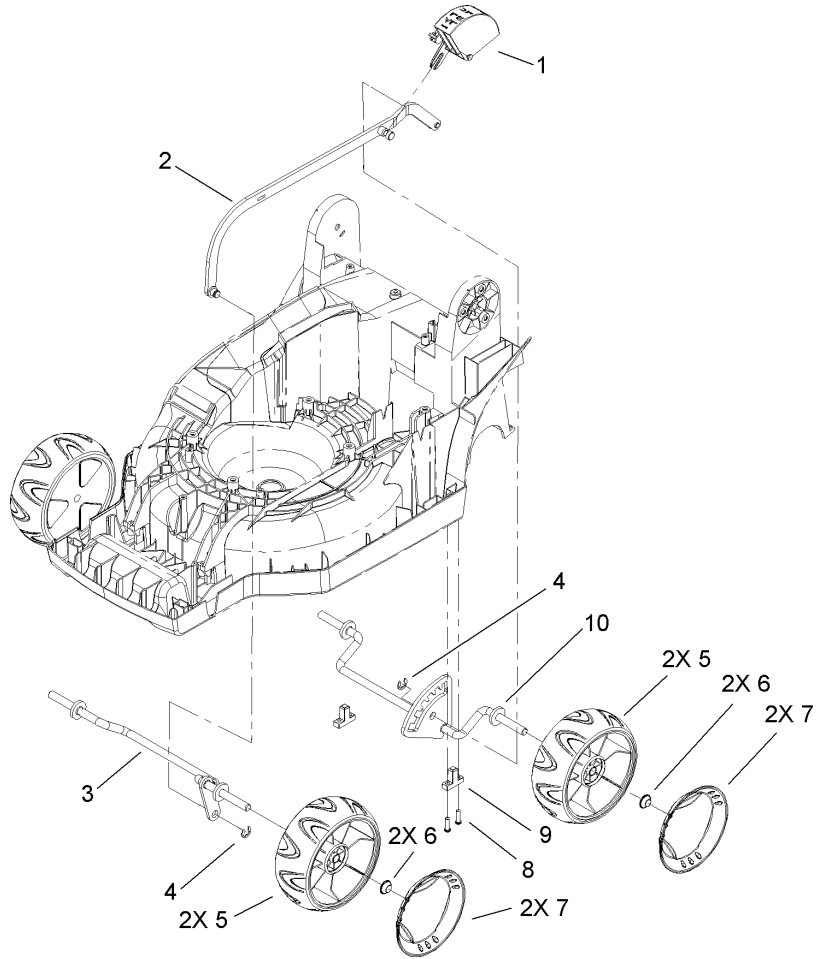

Single Point Height-of-Cut Assembly

Ref	Part No.	Qty.	Description
1	110-8421	1	Indicator-HOC
2	110-1262	1	Axle Link ASM
3	110-1203	1	Front Axle ASM
4	110-1266	2	E-Clip-Din, 8Mm
5	110-1148	4	Tire ASM
6	110-1278	4	Cap-Starlock, Push
7	110-1149	4	Cover-Wheel
8	110-1271	4	Screw-Torx, Pan Head
9	110-1216	2	Clamp-Axle, Rear
10	110-1204	1	Rear Axle ASM

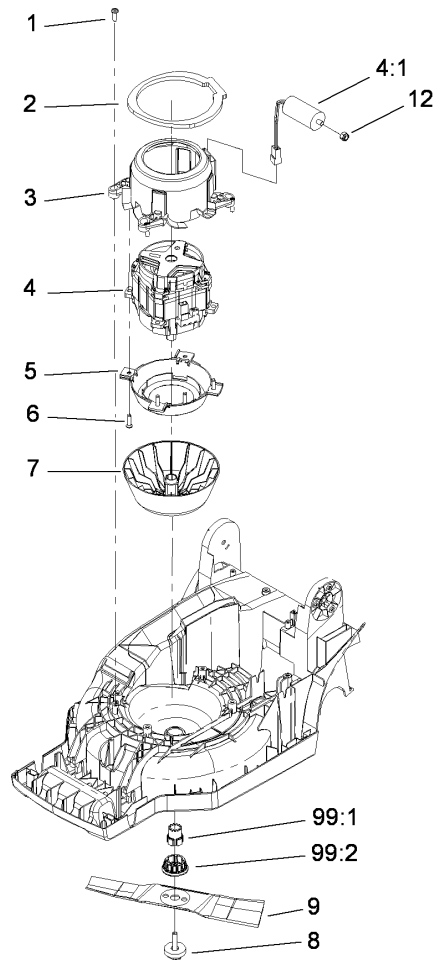

Motor and Blade Assembly

Ref	Part No.	Qty.	Description				
1	110-8453	4	Screw-PPH				
2	110-1228	1	Gasket-Rubber, Motor				
3	110-1227	1	Case-Motor, Upper				
4	112-3931	1	Motor-1200W				
4:1	110-1126	1	Capacitor-Motor				
5	110-1122	1	Case-Motor, Lower				
6	110-1272	4	Screw-PFH, Countersink				
7	115-3105	1	Fan-Motor				
8	110-8459	1	Bolt-Mount, Blade				
9	110-8409	1	Blade-34 Cm				
12	110-1275	1	Nut-Hex, Nyloc				
99		1	Adapter ASM				
99:1	114-5388	1	Adapter-Blade				
99:2	115-3101	1	Adapter-Mount, Blade				

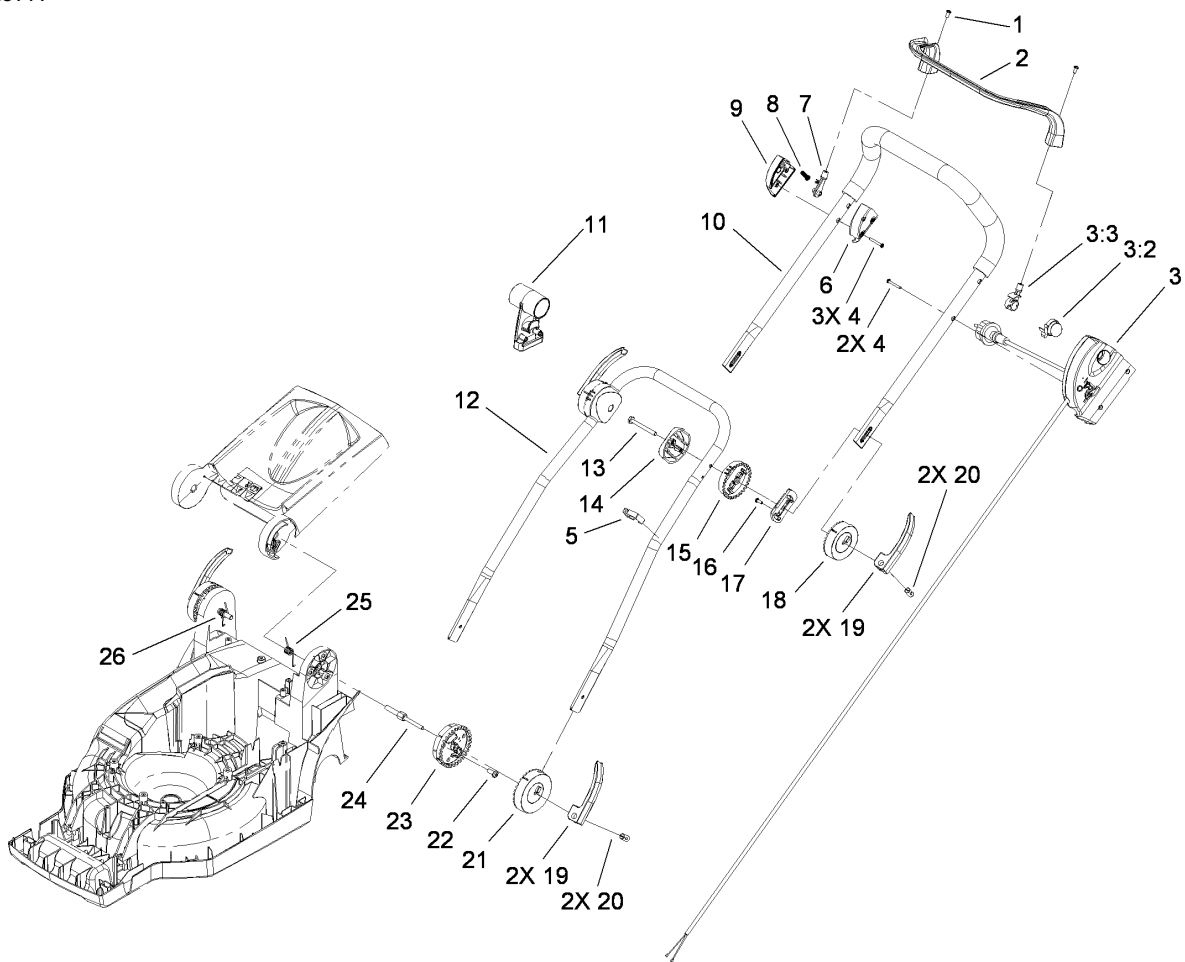

Handle Assembly

Ref	Part No.	Qty.	Description
1	110-1269	2	Screw-Torx, Pan Head
2	110-1237	1	Arm-Bail
3	112-3908	1	Switch ASM
3:2	110-1169	1	Button-Switch
3:3	110-1170	1	Pivot-Mount, Arm
4	110-1268	5	Screw-Torx, Pan Head
5	110-8439	1	Guide-Cable
6	110-1165	1	Housing-Pivot, LH
7	110-1164	1	Pivot-Mount, Arm
8	110-1166	1	Spring-Compression
9	110-1163	1	Housing-Pivot, RH
10	110-1234	1	Upper Handle ASM
11	110-1178	1	Hanger-Cable, Tube
12	110-1232	1	Tube-Handle, Lower
13	110-1263	2	Bolt-Mounting, Handle
14	110-1156	2	Clamp-Handle
15	110-1157	2	Mount-Handle, Ratchet
16	110-8438	8	Screw-Torx, Flanged Head
17	110-8404	2	Plate-Midpoint, Adjust Handle
18	110-1177	2	Adapter-Handle, Ratchet
19	112-3924	4	Lever-Locking, Handle
20	110-1180	4	Pivot-Pin, Threaded
21	110-1155	2	Adapter-Handle, Ratchet
22	110-1273	6	Screw-Torx, Pan Head

Ref	Part No.	Qty.	Description
23	112-3922	2	Mount-Handle Ratchet
24	110-1291	2	Spindle-Bolt, Handle
25	110-1230	1	Spring-Torsion, LH
26	110-1229	1	Spring-Torsion, RH

Attachments and Accessories

For 21083 - Eurocycler 34cm Electric Lawn Mower

Product Name

Model/Part

Rear Roller Kit 21085

NOTES

NOTES

NOTES

