



828LXE Power Max Snowthrower

Model No. 38631 - 250000001 and up.

Parts Catalog

Ordering Replacement Parts

To order replacement parts, please supply the part number, the quantity, and the description of each part desired.

Understanding Reference Numbers

Each identified part in an illustration has a reference number. The reference number for a part also appears in the parts list, along with other information about the part.

This catalog uses two special reference number formats, one to indicate parts in a service assembly and another to indicate the quantity of a given part in an illustration.

Service Assembly Reference Numbers

Parts in service assemblies have reference numbers in the form a:b. The a represents the reference number of the entire service assembly and the b represents a sequential number unique to each part within the service assembly.

For example, a wheel assembly might be identified by reference number 6, the tire by 6:1, the valve by 6:2, and the wheel by 6:3. When you order the assembly identified by reference number 6, you receive all parts identified by reference numbers 6:1, 6:2, and 6:3. However, you may also order any part individually. Reference numbers of this type appear in illustrations and in part lists.

Reference Numbers Indicating Quantity

In an illustration, if a reference number indicates more than one part, the reference number has the form nX y. The n represents the quantity of the part, the X is the multiplication symbol, and the y represents the reference number.

For example, in an illustration, the reference number 2X 37 means that two of the parts identified by reference number 37 are indicated.

Contents

Description	Page	Description	Page
Auger and Housing Assembly 3	Engine Assembly No. 1 Tecumseh HMSK-80 155724X 14
28 Inch Auger Gearcase Assembly No. 106-7254 4	Engine Assembly No. 2 Tecumseh HMSK-80 155724X 16
Chute Assembly 5	Carburetor Assembly No. 640052 Tecumseh HMSK-80 155724X 18
Chain Drive Assembly 6	220 Volt Electric Starter Assembly No. 37102 Tecumseh HMSK-80 155724X 19
Wheel Clutch Sprocket Assembly 7	Rewind Starter Assembly No. 590749 Tecumseh HMSK-80 155724X 20
Frame Assembly 8	Rewind Starter Assembly No. 590733 (Optional) Tecumseh HMSK-80 155724X 21
Handle and Control Assembly 10	Attachments and Accessories List 22
Handle, Headlamp and Control Assembly 11		
Chute Control Assembly 12		
Engine Assembly 13		

Part Description Abbreviations

Part descriptions in this catalog may include the following abbreviations.

AR. as required	HYD. hydraulic
ASM. assembly	LH. left hand
BBC. blade brake clutch	NI. nylon insert
CARR. carriage	NPTF. national pipe thread fine
DEG. degrees	PFH. phillips flat head
EXT. external	PPH. phillips pan head
FH. flat head	PPHTF. phillips pan head thread forming
GA. gauge	PRH. phillips round head
HD. heavy-duty	PTH. phillips truss head
HF. hex flange	PTO. power-take-off
HH. hex head	RH. right hand
HHF. hex head flange	ROPS. roll-over protection system
HHFTF. hex head flange thread forming	SFH. slotted fillister head
HJ. hex jam	SHH. slotted hex head
HLH. hex lag head	SHWH. slotted hex washer head
HOC. height-of-cut	SPH. slotted pan head
HSBH. hex socket button head	SQH. square head
HSFH. hex socket flat head	SRH. slotted round head
HSH. hex socket head	STD. standard
HWH. hex washer head	TAP. self tapping
HWHTF. hex washer head thread forming	TTH. torx truss head

Footnotes

- | | |
|--|---------------------------------|
| ❶ Not illustrated | ❷ Not serviced separately |
| ❸ Obtain from your local Tecumseh dealer | ❹ Included in Gasket Set 36450C |

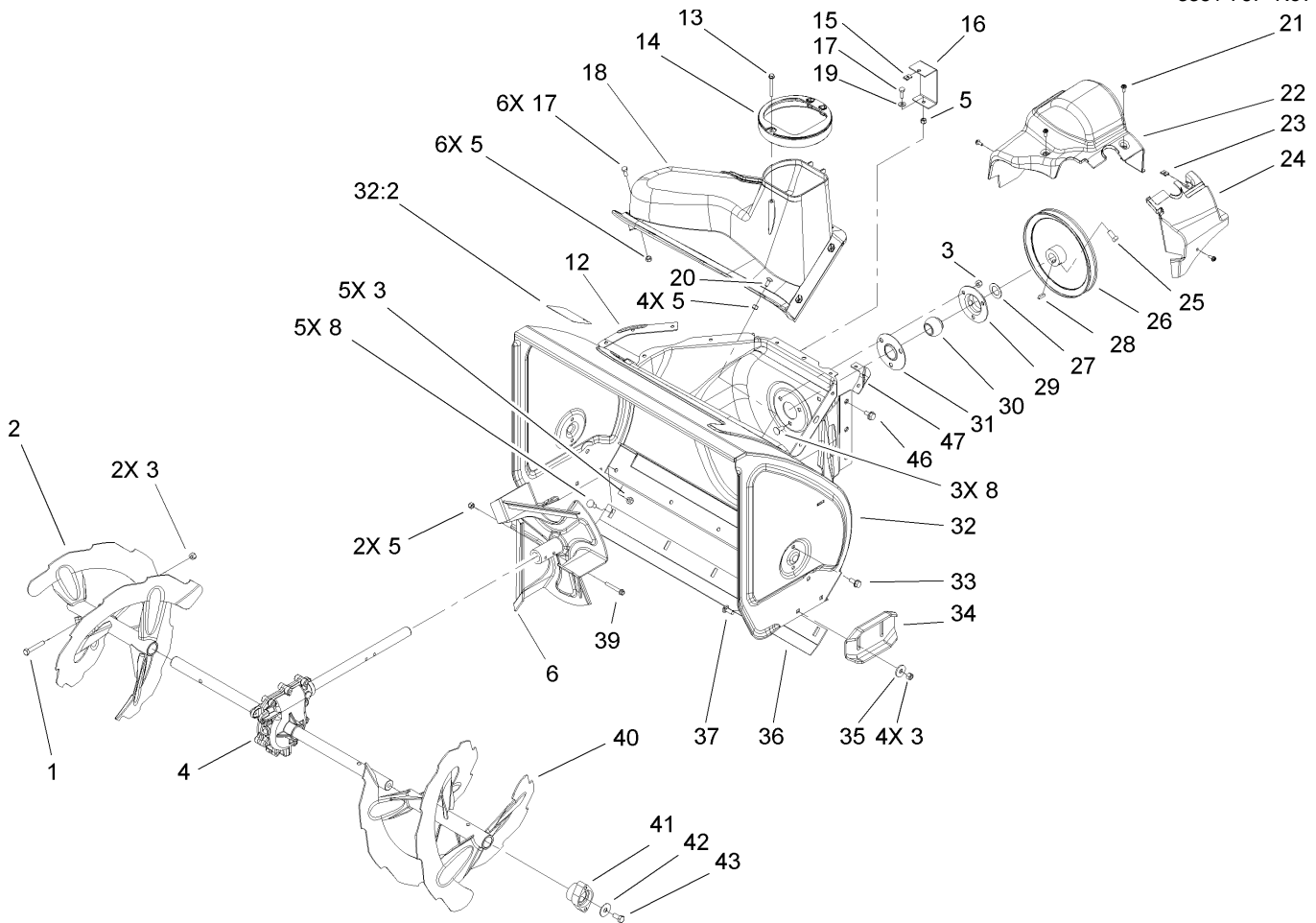

Auger and Housing Assembly

Ref	Part No.	Qty.	Description
1	322-10	2	Screw-HH
2	106-7291-03	1	Auger-RH
3	3296-29	14	Nut-Lock, NI
4	106-7254	1	Auger Gearcase ASM
5	3296-42	13	Nut-Lock, NI
6	106-4576-03	1	Impeller ASM
8	3230-23	8	Screw-CARR
12	107-1017-03	1	Seal-Flange, Cover
13	107-3003	1	Screw-Plastite
14	107-3006	1	Guide-Chute
15	107-1013	1	Nut-Speed, U-Type
16	107-1014-03	1	Bracket-Cover, Clip Nut
17	321-4	7	Screw-HH
18	108-0017	1	Cover
19	3256-22	1	Washer-Flat
20	3229-1	4	Screw-CARR
21	32144-112	4	Screw-HWH
22	107-1001	1	Cover-Belt
23	701493	1	Nut-Speed
24	107-1016	1	Cover-Extension, Belt
25	3242-4	2	Screw-Set, SQH
26	62-1300	1	Pulley-Impeller
27	252-80	1	Washer-Thrust
28	3257-23	1	Key-Woodruff

Ref	Part No.	Qty.	Description
29	26-6110	1	Flange-Cup, Bearing
30	63-3450	1	Bearing-Ball
31	26-6120	1	Flange-Cup, Bearing
32	107-3824	1	Housing- Auger, 28 Inch
32:2	107-3040	1	Decal-Danger, Auger
33	32144-70	4	Screw-HWHTF
34	106-4588-01	2	Skid
35	52-2861	4	Washer
36	106-4573-01	1	Scraper-Fixed
37	3230-16	4	Screw-CARR
39	321-44	2	Screw-HHF
40	106-7301-03	1	LH Auger ASM
41	106-4570	2	Auger-Bearing
42	3-0750	2	Washer
43	323-4	2	Screw-HH
46	32144-14	6	Screw-HWHTF
47	108-0039-03	1	Seal

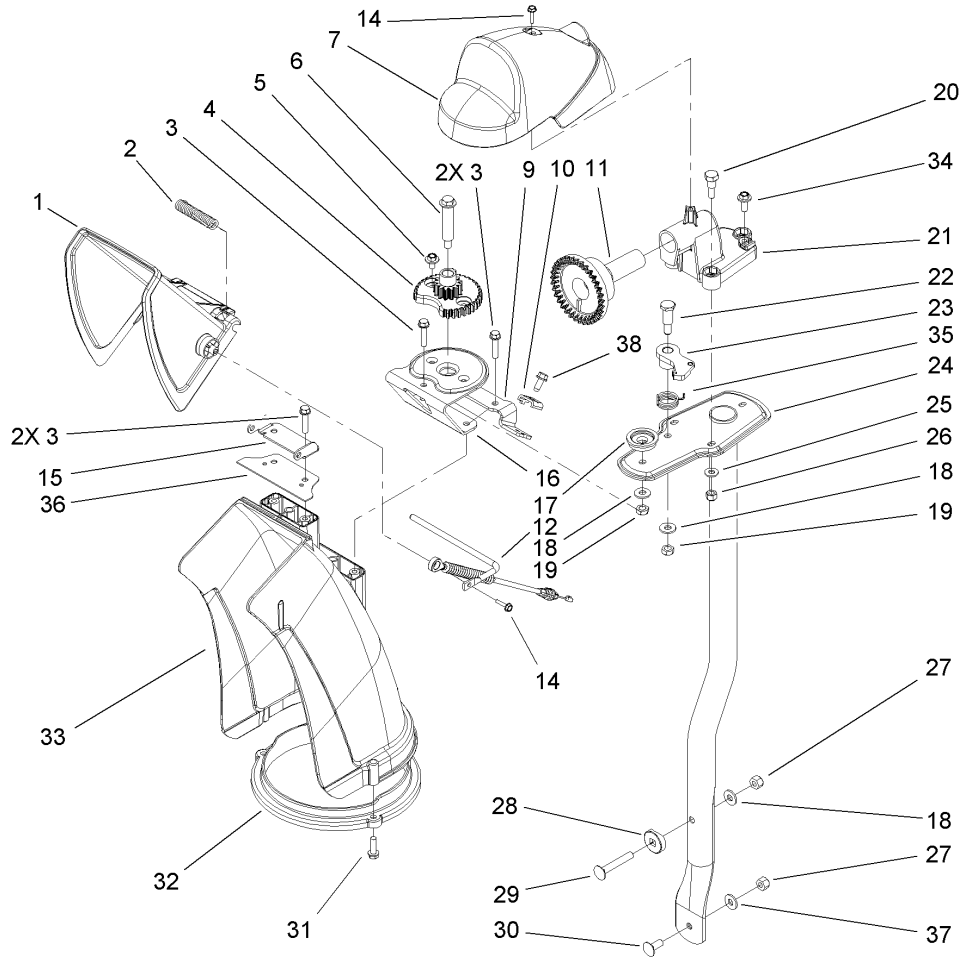

Chute Assembly

Ref	Part No.	Qty.	Description
1	106-7309	1	Deflector-Chute
2	106-4594	1	Spring-Torsion
3	46-8092	5	Screw-Plastite
4	106-4472	1	Gear-Chute
5	46-6810	2	Screw And Washer ASM
6	100-9880	1	Bolt-Shoulder
7	106-4585	1	Cover-Gear, Chute
9	106-7296	1	Bracket-Cable, Clamp
10	106-7297	1	Clamp-Cable
11	106-4471	1	Gear-Face
12	107-1021	1	Rod-Deflector
14	98-1375	2	Screw-HWH
15	106-7266	1	Bracket-Deflector
16	106-4582-03	1	Bracket-Support, Chute
17	106-4422	1	Spacer-Chute
18	3256-2	3	Washer-Flat
19	3296-47	2	Nut-Lock, NI
20	106-7276	3	Screw-Shoulder
21	106-7257	1	Mount-Gear, Face
22	63-2650	1	Screw-Shoulder
23	106-4476	1	Latch-Chute
24	106-7253-03	1	Tube-Support
25	3256-22	3	Washer-Flat
26	3296-42	3	Nut-Lock, NI

Ref	Part No.	Qty.	Description
27	3296-29	2	Nut-Lock, NI
28	106-7260	1	Washer-Curved
29	3230-5	1	Screw-CARR
30	3230-23	1	Screw-CARR
31	46-8091	3	Screw-HWH
32	105-9991	1	Ring-Chute
33	106-4440	1	Chute-Discharge
34	46-6811	1	Screw-HWH
35	106-4475	1	Spring-Torsion
36	107-1019	1	Seal-Chute
37	3290-456	1	Washer-Belleville
38	32144-10	1	Screw-HWH

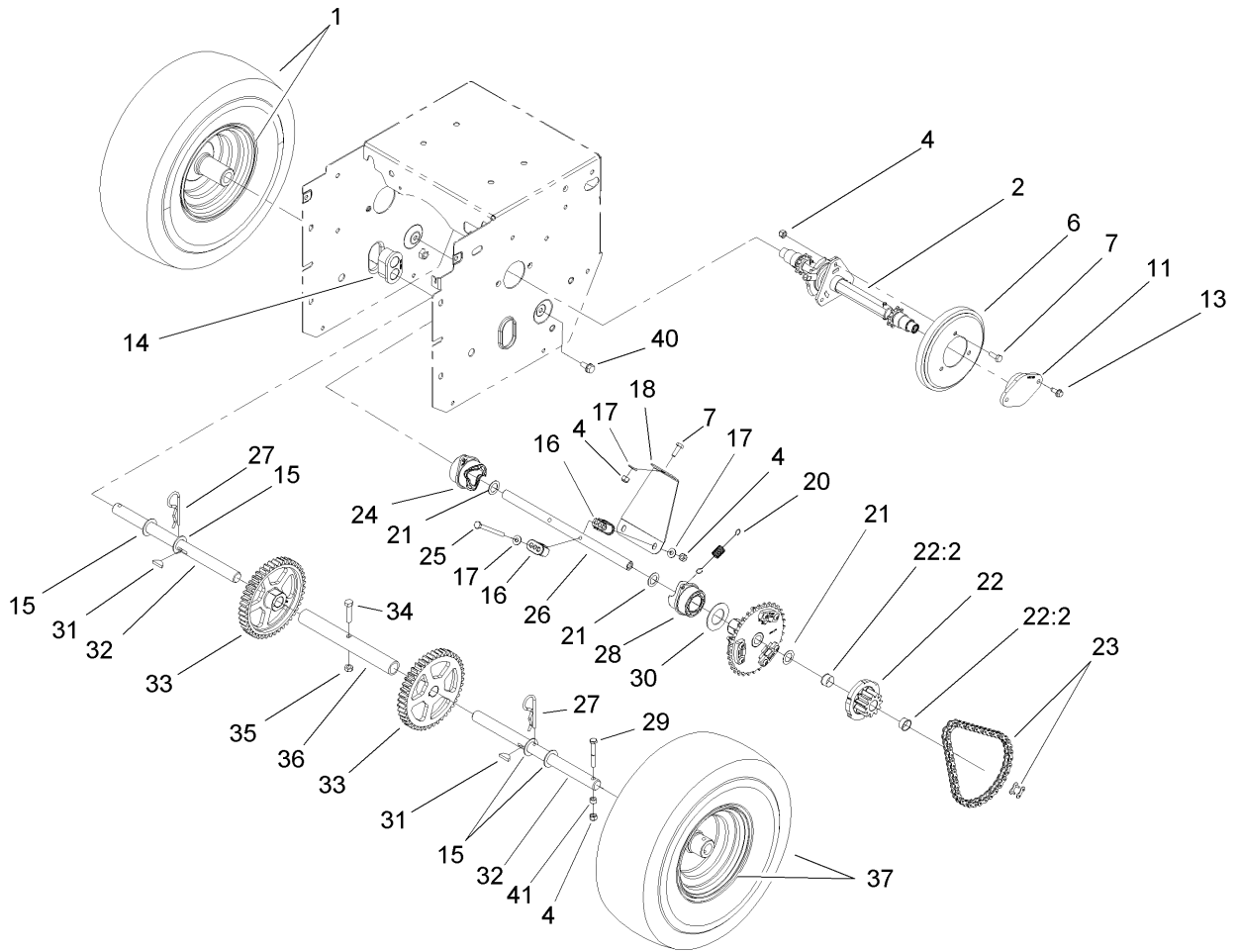

Chain Drive Assembly

Ref	Part No.	Qty.	Description
1		1	RH Wheel And Tire ASM
1	107-3042	1	Tire
1	107-3043	1	Rim-Tire
2	108-2989	1	Clutch Hexshaft ASM
4	3296-42	8	Nut-Lock, NI
6	106-4480	1	Wheel-Friction
7	321-4	4	Screw-HH
11	108-2981	2	Retainer-Bearing
13	32144-10	4	Screw-HWH
14	106-4558	2	Bearing-Axle
15	3-8664	4	Washer-Thrust
16	107-8889	4	Guide-Collar
17	3256-22	5	Washer-Flat
18	107-8892-03	1	Brace-Collar, Shift
20	107-8893	2	Spring-Extension
21	108-0015	4	Washer-Flat
22	107-8894	2	11T Gear ASM
22:2	108-2973	2	Bushing-Flange
23	108-0016	2	Chain-Roller
23	2710-6	2	Link-Connecting
24	107-8888	1	Collar-Shift, RH
25	321-23	2	Screw-HH
26	107-8883	1	Shaft-Intermediate
27	3290-343	2	Pin-Hair

Ref	Part No.	Qty.	Description
28	107-8887	1	Collar-Shift, LH
29	108-2975	2	Screw-HH
30	107-8891	2	Washer-Thrust
31	3257-7	2	Key-Woodruff
32	107-8898	2	Shaft-Axle
33	106-4572	2	Gear-Axle, 44 Tooth
34	322-17	1	Screw-HH
35	3296-47	1	Nut-Lock, NI
36	106-7259	1	Tube-Axle
37		1	LH Wheel And Tire ASM
37	107-3042	1	Tire
37	107-3043	1	Rim-Tire
40	32144-14	2	Screw-HWHTF
41	55-9370	2	Spacer-Blade, Rotor

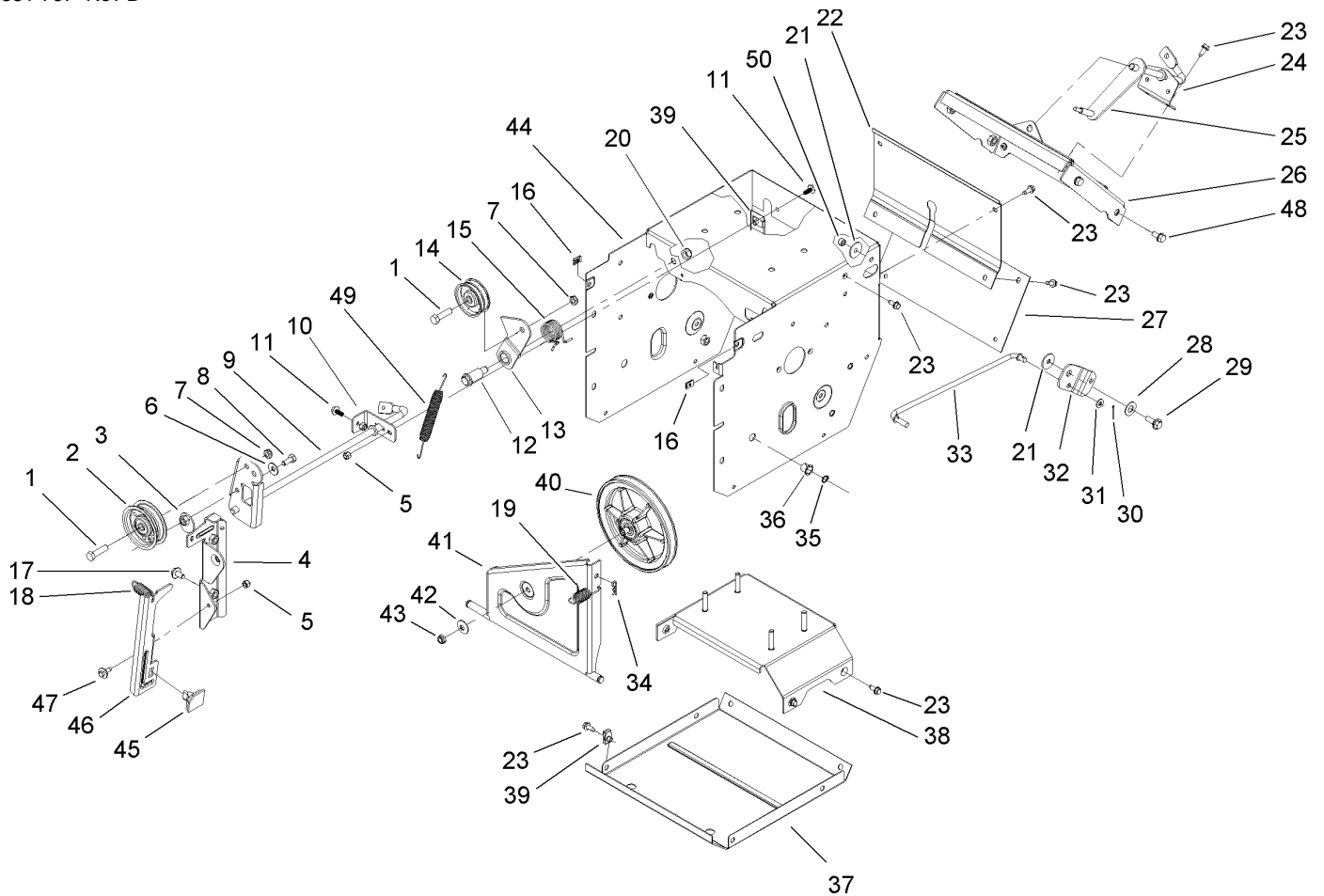

Frame Assembly

Ref	Part No.	Qty.	Description
1	323-8	2	Screw-HH
2	92-7104	1	Pulley-Idler
3	107-1047	1	Nut
4	107-1039	1	Bracket-Idler, Impeller
5	3296-42	3	Nut-Lock, NI
6	3290-456	1	Washer-Belleville
7	3296-59	2	Nut-Lock, NI
8	322-3	1	Screw-HH
9	107-3838-03	1	Impeller Clutch ASM
10	106-7341	1	Bracket-Rear, Clutch
11	99-6810	2	Screw-HH
12	107-1022	1	Bolt-Shoulder
13	108-0011	1	Arm-Idler, Traction
14	3-4244	1	Pulley-Idler
15	108-0010	1	Spring-Torsion
16	107-1013	2	Nut-Speed, U-Type
17	3234-7	2	Screw-HHF
18	107-1045	1	Spring-Extension
19	107-1003	1	Spring-Extension
20	3296-76	1	Nut-Lock, NI
21	5-4460	2	Washer-Pivot
22	108-0022-01	1	Cover-Upper
23	32144-10	17	Screw-HWH
24	108-0036	1	Bracket-Rod, Shift

Ref	Part No.	Qty.	Description
25	106-7268	1	Lever-Control, Traction
26	108-0026-01	1	Shift Plate ASM
27	106-7345-01	1	Cover-Lower
28	25-5640	1	Washer
29	27-0410	1	Screw-Shoulder
30	3272-4	1	Pin-Cotter
31	3256-23	1	Washer-Flat
32	107-1011	1	Bellcrank-Drive
33	106-4467	1	Link-Control, Speed
34	3290-307	1	Pin-Hair
35	32151-61	2	Ring-Retaining
36	256-257	2	Bushing-Nyliner
37	106-7330-01	1	Pan-Bottom
38	106-7315	1	Brace Frame ASM
39	107069	8	Clip
40	108-0031	1	Traction Pulley ASM
41	108-0032	1	Pulley Pivot ASM
42	3290-340	1	Washer-Belleville
43	3296-5	1	Nut-Lock
44	108-0019-01	1	Traction Frame ASM
45	66-8060	1	Pad-Brake
46	107-1000	1	Arm-Brake
47	92-9698	1	Screw-Shoulder
48	32144-14	4	Screw-HWHTF

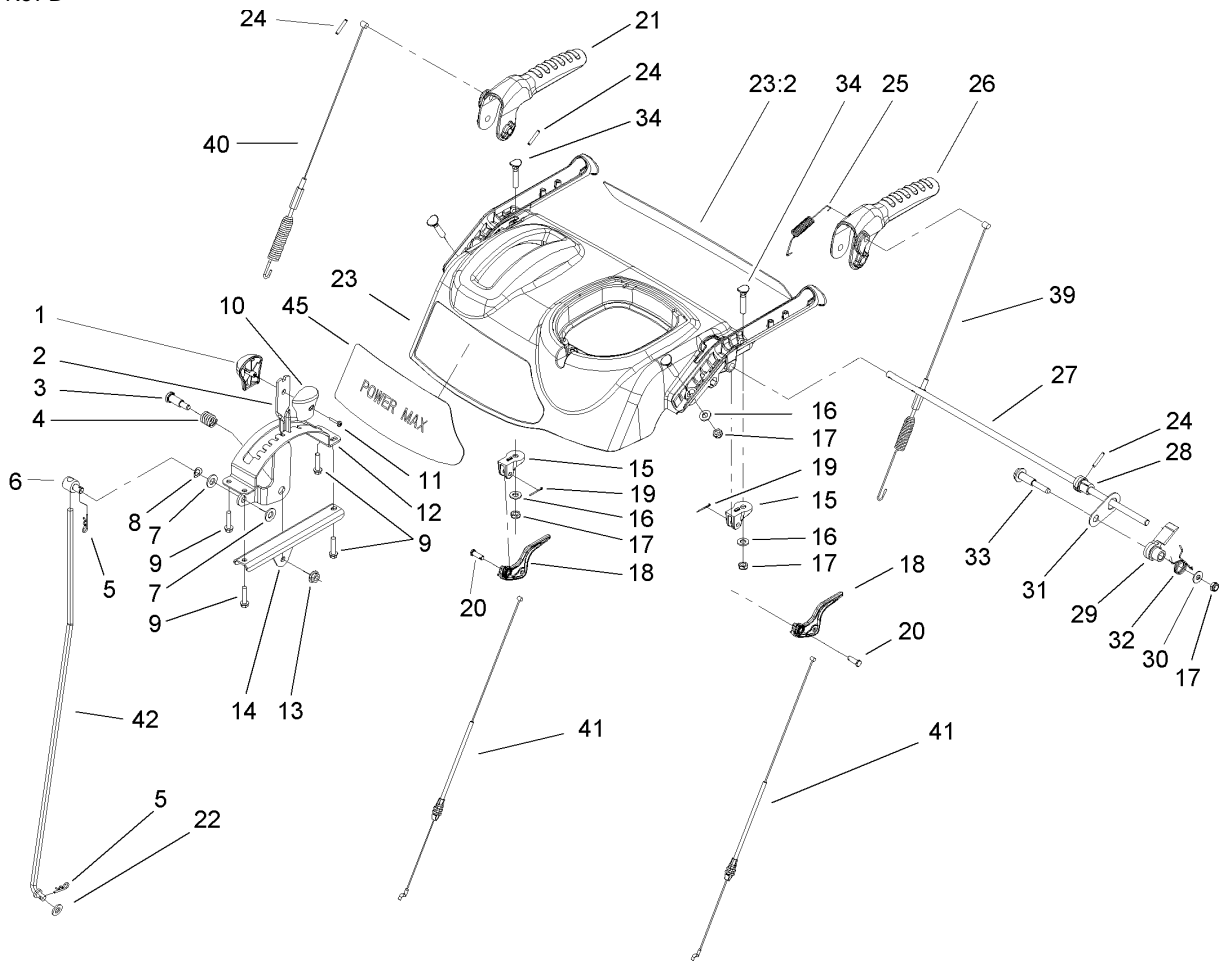

Handle and Control Assembly

Ref	Part No.	Qty.	Description
1	106-4423	1	Knob-Shift, RH
2	106-7278-03	1	Selector-Speed
3	63-2650	1	Screw-Shoulder
4	107-3017	1	Spring-Compression
5	3290-307	2	Pin-Hair
6	101161	1	Trunnion
7	3256-24	2	Washer-Flat
8	612586	1	Washer-Spring
9	46-8092	4	Screw-Plastite
10	105-9999	1	Knob-Shift, LH
11	94-4496	1	Screw-PPH
12	106-7277-03	1	Guide-Selector, Speed
13	32128-13	1	Nut-HF
14	106-7279-03	1	Mount-Selector, Speed
15	105-9980	2	Mount-Clutch, Lever
16	3256-70	4	Washer-Flat
17	3296-72	5	Nut-Lock, NI
18	106-4505	2	Lever-Clutch
19	3272-4	2	Pin-Cotter
20	1-808265	2	Pin-Clevis
21	106-4413	1	Lever-Auger
22	3256-38	1	Washer-Flat
23	108-2970	1	Control Panel ASM
23:2	108-2968	1	Decal

Ref	Part No.	Qty.	Description
24	32121-125	3	Pin-Spring
25	107-3001	1	Spring-Tension
26	106-4410	1	Lever-Traction
27	105-9996	1	Rod-Lockout
28	107-1043	1	Cam-Lockout
29	108-0023	1	Latch-Lockout
30	98-3499	1	Washer-Flat
31	107-3000	1	Link-Lockout
32	108-0024	1	Spring-Torsion
33	106-4412	1	Screw-Shoulder
34	107-3018	4	Screw-Handle
39	106-4563	1	Cable-Traction
40	106-4599	1	Cable-Auger
41	107-8896	2	Cable-Clutch
42	107-1005	1	Rod-Shift
45	108-2966	1	Decal-Panel, Control

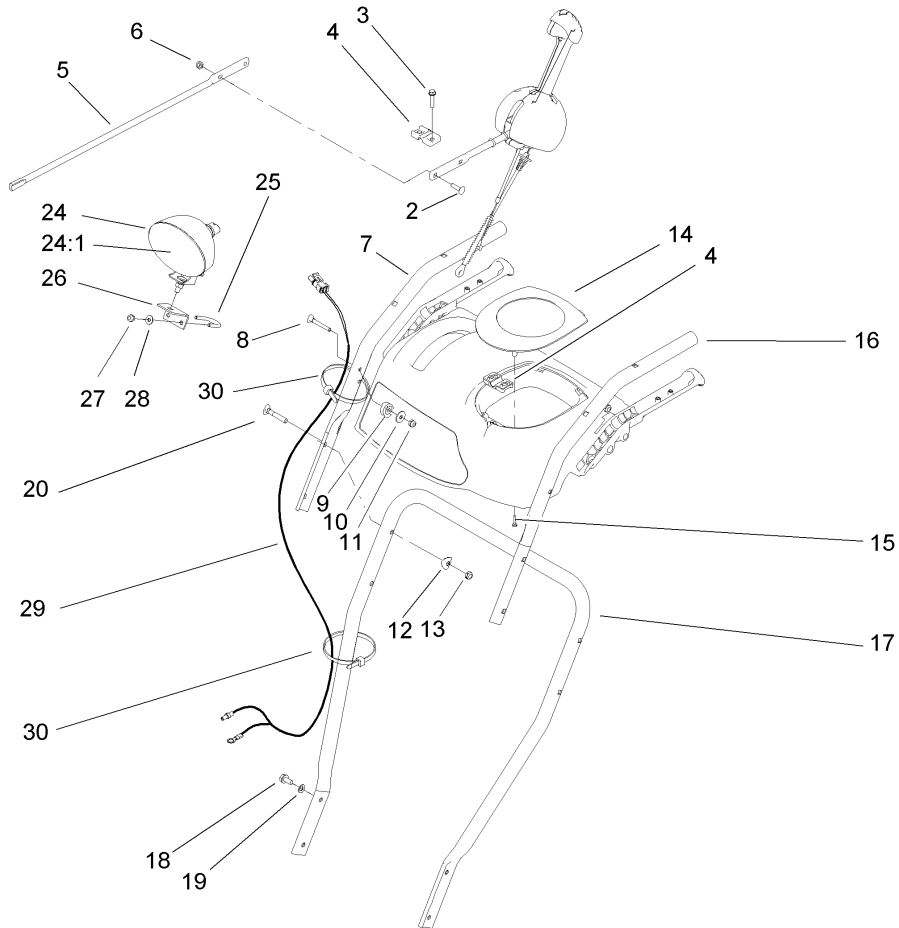

Handle, Headlamp and Control Assembly

Ref	Part No.	Qty.	Description	Ref	Part No.	Qty.	Description
2	3229-30	2	Screw-CARR	28	3256-1	2	Washer-Flat
3	46-8092	2	Screw-Plastite	29	106-4511	1	Harness-Wire
4	105-9987	2	Support-Rod	30	614249	2	Strap-Tie
5	106-7283	1	Rod-Chute, Front				
6	3296-73	2	Nut-Lock, NI				
7	108-0038-03	1	Handle-Upper, RH				
8	95-4453	2	Screw				
9	106-4509	2	Clamp-Cable				
10	87-6630	2	Washer-Plain				
11	3296-73	2	Nut-Lock, NI				
12	107-3844	4	Washer				
13	3296-72	4	Nut-Lock, NI				
14	106-4586	1	Cover-Panel, Control				
15	94-4496	2	Screw-PPH				
16	108-0037-03	1	Handle-Upper, LH				
17	105-9981-03	1	Handle-Lower				
18	32144-14	4	Screw-HWHTF				
19	3290-475	4	Washer-Belleville				
20	92-2260	4	Screw-Handle				
24	106-4510	1	Headlamp ASM				
24:1	108-0008	1	Lamp-12 Volt				
25	107-3024	1	Clamp				
26	107-1020-03	1	Bracket-Light				
27	3296-73	2	Nut-Lock, NI				

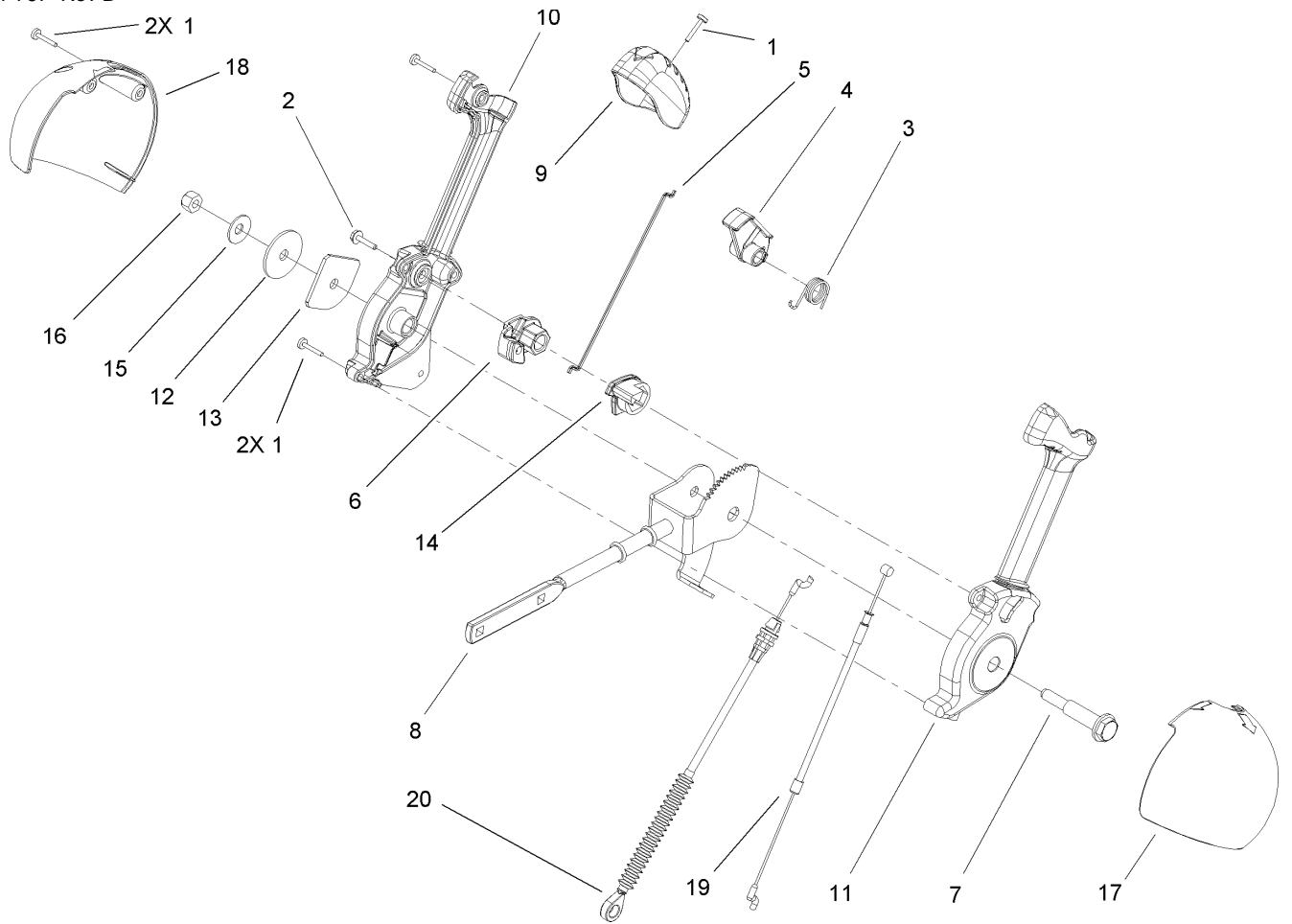

Chute Control Assembly

Ref	Part No.	Qty.	Description
1	94-4496	5	Screw-PPH
2	98-1375	1	Screw-HWH
3	105-9982	1	Spring-Torsion
4	105-9984	1	Trigger-Latch
5	105-9985	1	Link-Latch
6	105-9988	1	Lever-Cable, Deflector
7	105-9995	1	Screw-Shoulder
8	106-4479	1	Rod-Control, Chute
9	106-7280	1	Cap-Lever
10	106-7281	1	Lever-Chute Control, RH
11	106-7282	1	Lever-Chute Control, LH
12	107-3002	1	Washer-Nylon
13	106-7295	1	Plate-Friction
14	106-7310	1	Pawl-Latch
15	3290-456	1	Washer-Belleville
16	3296-29	1	Nut-Lock, NI
17	105-9986	1	Cover-Chute Lever, LH
18	106-7292	1	Cover-Chute Lever, RH
19	105-9989	1	Cable-Release, Chute
20	105-9990	1	Cable-Control, Deflector

--	--	--	--

Engine Assembly No. 1

Tecumseh HMSK-80 155724X

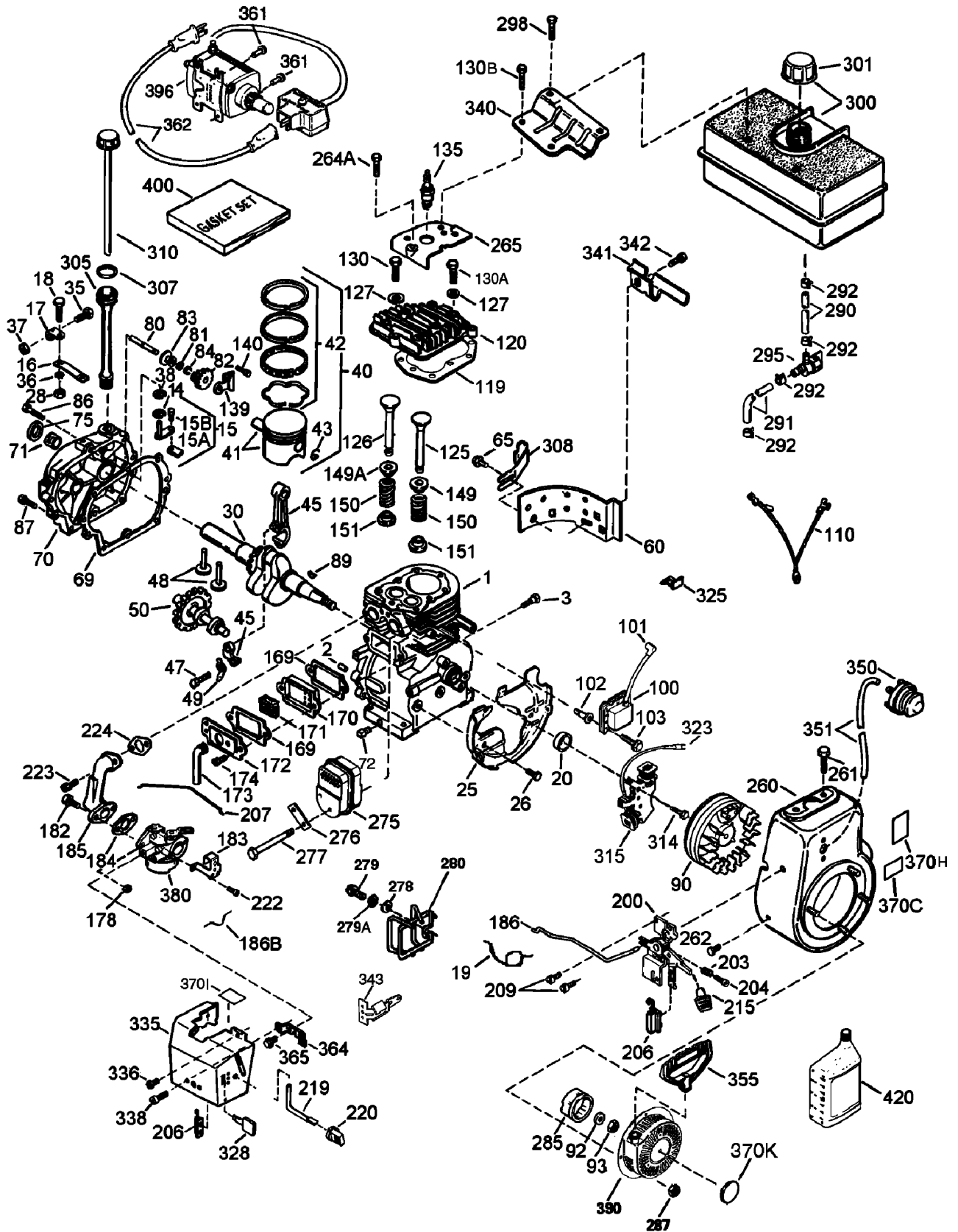

Engine Assembly No. 1

Tecumseh HMSK-80 155724X

Ref	Part No.	Qty.	Description	Ref	Part No.	Qty.	Description
③1	35385	1	Cylinder ASM (Incl. Ref. # 2, 20 And 72)	③89	32589	1	Key-Flywheel
③2	27652	2	Pin-Dowel	③90	611093	1	Flywheel ASM
③3	650820	2	Screw (1/4-20X1/2)	③92	650880	1	Washer-Belleville
③14	28277	1	Washer-Flat	③93	650881	1	Nut-Flywheel
③15	30699C	1	Rod-Governor (Incl. Ref. # 15A And 15B)	③100	35135A	1	Solid State Ignition (Incl. Ref. # 101)
③15A	30700	1	Yoke-Governor	③101	610118	1	Cover-Spark Plug
③15B	650494	1	Screw (6-40X5/16)	③102	651024	2	Stud-Mounting, Solid State
③16	33454A	1	Lever-Governor	③103	651007	2	Screw (T-15, 10-24 X 15/16)
③17	29916	1	Clamp-Lever, Governor	③110	35187	1	Wire-Ground
③18	651028	1	Screw (T-15, 8-32X7/16)	①③110A	37047	1	Wire-Ground
③19	34663	1	Spring-Throttle	③119	36448	1	Gasket-Head, Cylinder
③20	35319	1	Seal-Oil	③120	36449	1	Head-Cylinder
③25	36460	1	Baffle-Housing, Blower	③125	27878A	1	Exhaust Valve (STD.) (Incl. Ref. # 151)
③26	650561	2	Screw (1/4-20X19/32)	③125	27880A	1	Exhaust Valve (1/32" Os) (Incl. Ref. #151)
③28	30322	1	Nut-Lock (8-32)	③126	34035	1	Intake Valve (STD.) (Incl. Ref. # 151)
③30	35571A	1	Crankshaft	③127	650691	2	Washer-Flat
③35	29826	1	Screw (10-32X3/4)	③130	6021A	7	Screw (5/16-18X1-1/2)
③36	29918	1	Washer-Lock (8)	③130A	650727	2	Screw (5/16-18X1-25/32)
③37	29216	1	Nut-Lock (10-32)	③130B	651055	2	Screw (5/16-18X39/64)
③38	29642	1	Ring-Retaining	③135	35395	1	Spark Plug-Resistor (R J19 L M)
③40	40011	1	Piston-Pin And Ring Set (STD)	③139	33369	1	Bracket-Gear, Governor
③40	40012	1	Piston- Pin And Ring Set (.010 O S)	③140	650836	2	Screw (10-24X1/2)
③41	40009	1	Piston And Pin ASM (STD.) (Incl. Ref. #43)	③149	27882	1	Cap-Spring, Valve
③41	40010	1	Piston And Pin ASM (.010" Os) (Incl. Ref. #43)	③149A	35862	1	Cap-Spring, Valve
③42	40013	1	Ring Set (STD)	③150	27881	2	Spring-Valve
③42	40014	1	Ring Set (.010 O S)	③151	32581	2	Keeper-Spring, Valve
③43	27888	2	Ring-Retaining, Piston Pin	③④169	27896A	2	Gasket-Cover, Valve
③45	36897	1	Connecting Rod ASM. (Incl. Ref. # 47 And 49)	③170	28423	1	Body-Breather
③47	651033	2	Bolt-Rod, Connecting	③171	28424	1	Element-Breather
③48	34034	2	Lifter-Valve	③172	28425	1	Cover-Valve
③49	36896	1	Dipper-Oil	③173	35350	1	Tube-Breather
③50	35375	1	Camshaft (Mcr)	③174	650128	2	Screw (10-24X1/2)
③60	33273A	1	Extension-Housing, Blower	③178	29752	2	Nut And Lock Washer (1/4-28)
③65	650128	1	Screw (10-24X1/2)	③182	30088A	2	Screw (1/4-28X1)
③69	37342	1	Gasket-Cover, Cylinder	③183	34587A	1	Bracket-Choke
③70	35376A	1	Cylinder Cover (Incl. Ref. # 71, 75, 80-84)	③④184	33263	1	Gasket-Carburetor To Intake Pipe
③71	35377	1	Bushing-Crankshaft	③185	33877	1	Pipe-Intake
③72	27642	1	Plug-Drain, Oil (SQH 1/4-18)	③186	34667	1	Link-Governor
③75	35319	1	Seal-Oil	③186B	36652	1	Spring-Choke
③80	37587	1	Shaft-Governor	③200	34677	1	Control Bracket (Incl. Ref. # 19, 203, 204 And 206)
③81	651080	1	Washer				
③82	37588	1	Governor Gear ASM (Incl. Ref. # 81)				
③83	30588A	1	Spool-Governor				
③84	29193	1	Ring-Retaining				
③86	650833	7	Screw (1/4-20X1-3/16)				
③87	650832	1	Screw (1/4-20X1-11/16)				

Engine Assembly No. 2

Tecumseh HMSK-80 155724X

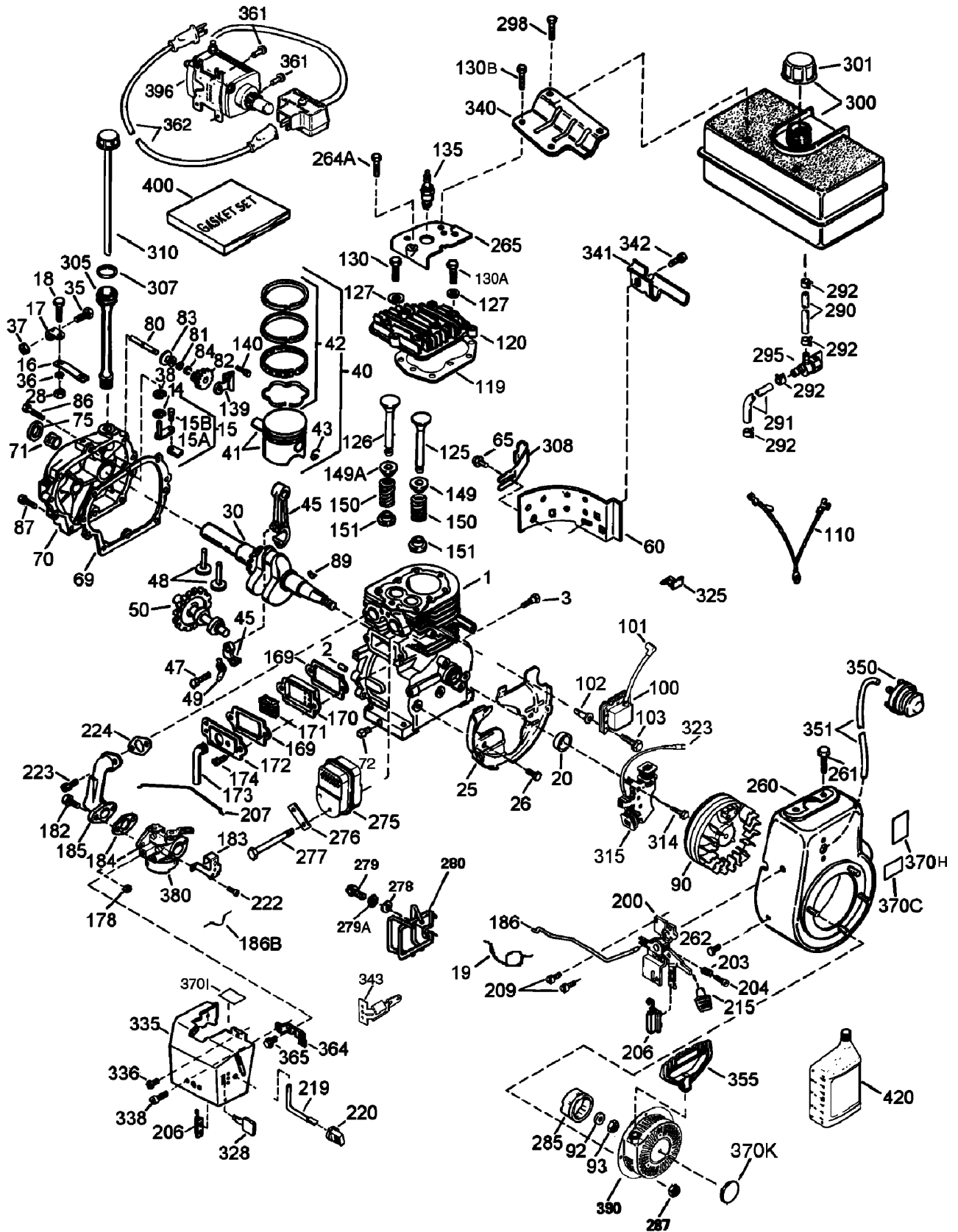

Engine Assembly No. 2

Tecumseh HMSK-80 155724X

Ref	Part No.	Qty.	Description	Ref	Part No.	Qty.	Description
③203	31342	1	Spring-Compression	①③343A	651060	1	Screw (8-32 X 23/64)
③204	651029	1	Screw (T-10, 5-40X7/16)	③350	570682A	1	Primer ASM
③206	610973	1	Terminal	③351	32180C	1	Line-Primer
③207	33878	1	Link-Throttle	③355	590574	1	Handle-Starter, Mitten Grip
③209	650821	2	Screw (10-32 X 1/2)	③361	650990	2	Screw (T-30, 1/4-20X15/32)
③215	35440	1	Knob-Control	③364	33377	1	Bracket-Carburetor
③219	34586	1	Rod-Choke	③365	650767	2	Screw (8-32X27/64)
③220	35438	1	Knob-Control	③370C	36501	1	Decal-Primer, International Symbol
③222	28820	2	Screw (10-32 X 1/2)	③370H	35077	1	Decal-Speed Control And Choke
③223	650378	2	Screw (T-30, 5/16-18X1-3/32)	③370I	37119	1	Decal-Warning (Bilingual)
③224	27915A	1	Gasket-Pipe, Intake	③370K	36695	1	Decal-Tecumseh Logo For Top Of Recoil Starter
③260	35447A	1	Housing-Blower	①③371D	36534	1	Decal-Instruction
③261	650788	2	Screw (5/16-18X3/4)	③380	640052	1	Carburetor (Incl. Ref. #184)
③262	29747B	2	Screw	③390	590749	1	Starter-Rewind
③264A	650802	1	Screw (1/2-20X5/8)	③396	37102	1	Electric Starter Motor ASM (220 Volt)
③265	33272D	1	Cover-Head, Cylinder (Black)	③400	36450C	1	Gasket Set
③275	35056	1	Muffler	③420	730226A	1	Oil-Engine, S A E 5W30
③276	31588	1	Plate-Locking				
③277	651002	2	Screw (5/16-18X4-3/16)				
③278	650147	2	Washer-Flat				
③279	650980	2	Screw (10-16 X 47/64)				
③279A	650979	2	Washer-Lock				
③280	36294	1	Muffler Heat Shield ASM				
③285	35985B	1	Cup-Starter				
③287	29752	4	Nut And Lock Washer (1/4-28)				
③290	29774	1	Line-Fuel (8.62)				
③291	30962	1	Line-Fuel				
③292	26460	4	Clamp-Line, Fuel				
③295	35857	1	Fuel Shut-Off Valve ASM (Incl. Ref. # 292)				
③298	650665	2	Screw (1/4-15X7/8)				
③300	34156A	1	Fuel Tank (Incl. Ref. # 292 And 301)				
③301	36246	1	Cap-Fuel				
③305	35554	1	Tube-Fill, Oil				
③307	35499	1	O-Ring				
③308	35540	1	Clip-Tube, Fill				
③310	36205	1	Gauge Oil ASM				
③314	650873	1	Screw (1/4-20 X 3/4)				
③315	611111	1	Alternator Coil ASM (18 Watt)(Incl. Ref. #322)				
③323	611118	1	Terminal				
③325	29443	1	Clip-Wire				
③328	35062	2	Key-Ignition				
①③329	610973	1	Terminal				
③335	36547	1	Cover-Carburetor (Black)				
③336	650765	1	Screw (10-32X1/2)				
③338	28942	2	Screw (10-32 X 3/8)				
③340	34154	1	Bracket-Tank, Fuel (Black)				
③341	34155	1	Bracket-Tank, Fuel				
③342	650561	1	Screw (1/4-20X19/32)				
③343	35079A	1	Key Switch Bracket (Incl. Ref. #343A)				

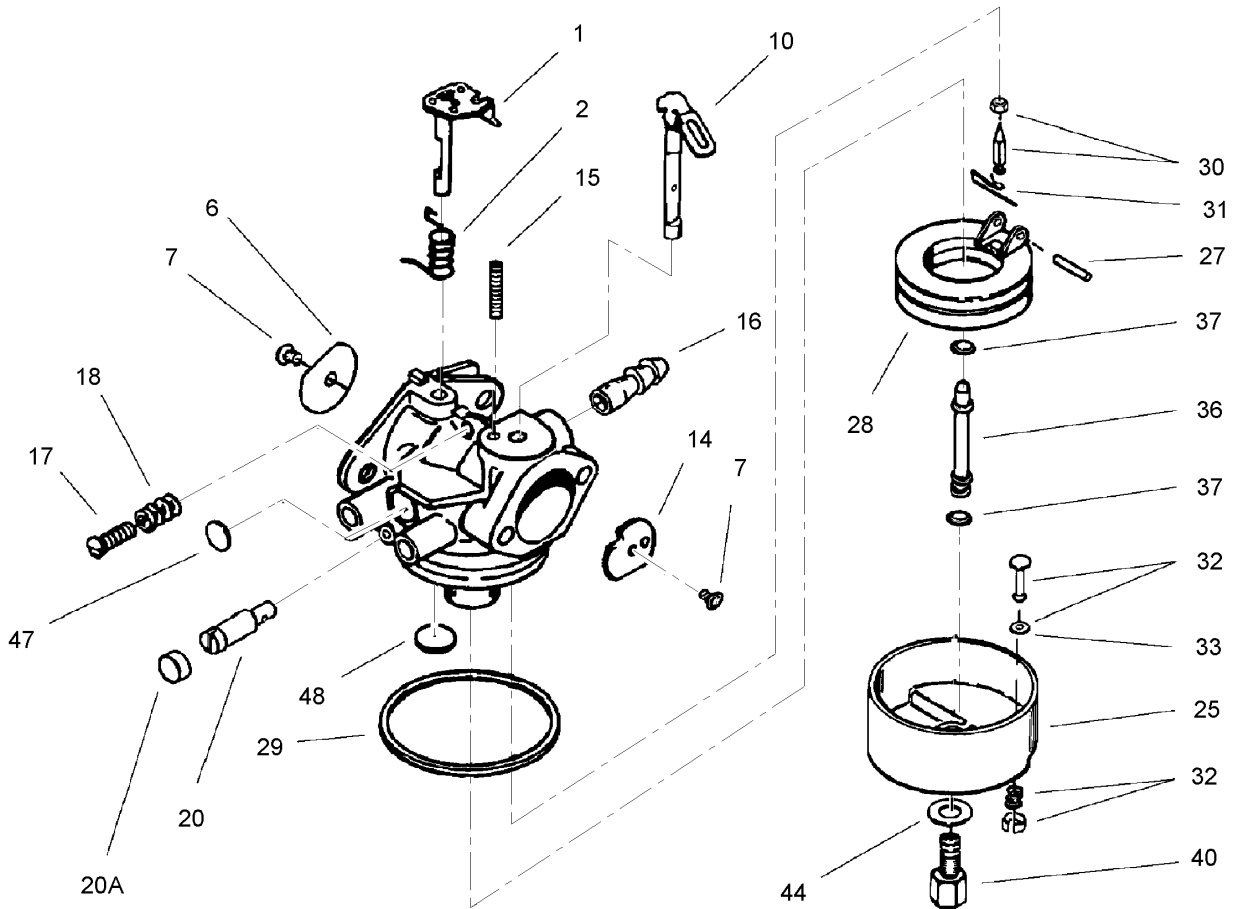

Carburetor Assembly No. 640052 Tecumseh HMSK-80 155724X

Ref	Part No.	Qty.	Description
❶	631776A	1	Throttle Shaft And Lever ASM
❷	631970	1	Spring-Return, Throttle
❸	631778	1	Shutter-Throttle
❹	650506	2	Screw-Shutter
❺	632112	1	Choke Shaft And Lever ASM
❻	632174	1	Shutter-Choke
❼	630735	1	Spring-Positioning, Choke
❽	632164	1	Fitting-Fuel
❾	650417	1	Screw-Throttle Crack Screw / Idle Speed
❿	630766	1	Spring-Tension
⓫	640016	1	Screw-Restrictor, Idle
⓬	640053	1	Cap-Screw, Idle Restrictor
⓭	631951	1	Float Bowl ASM (Incl. Ref. # 32 And 33)
⓮	631024	1	Shaft-Float
⓯	632019	1	Float
⓰	631028	1	O Ring-Bowl, Float
⓱	631021	1	Inlet Needle, Seat And Clip (Incl. Ref. # 31)
⓲	631022	1	Clip-Spring
⓳	27136A	1	Bowl Drain ASM
⓴	27554	1	Gasket-Plunger, Drain
⓵	640005	1	Tube-Nozzle, Main
⓶	632547	2	O-Ring

Ref	Part No.	Qty.	Description
⓷	640055	1	Nut-High Speed, Bowl
⓸	27110	1	Washer-Bowl Nut
⓹	630748	1	Plug-Welch, Idle Mixture Well
⓺	631027	1	Plug-Welch, Atmospheric Vent

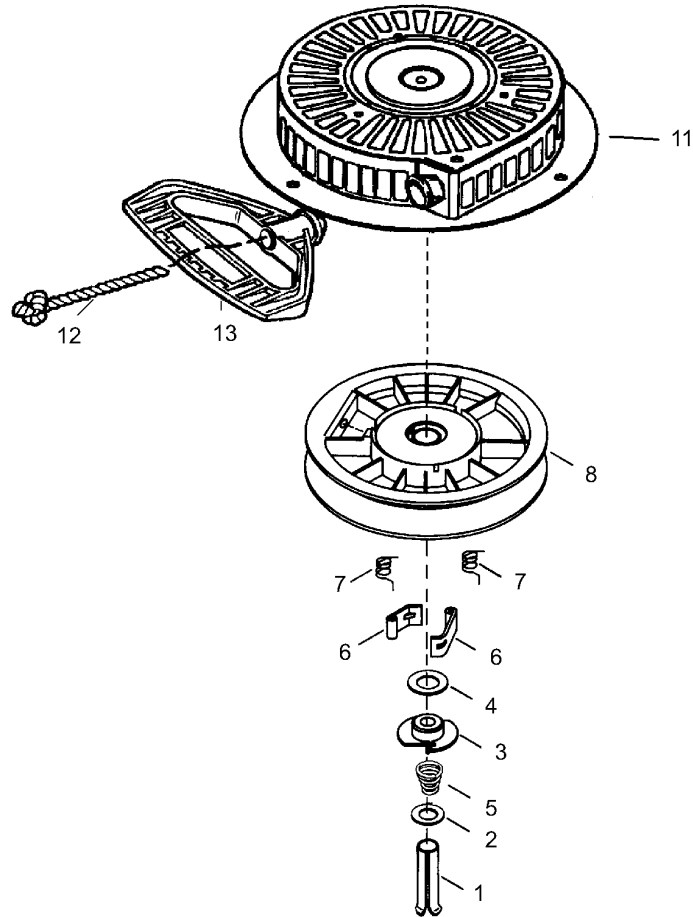

Rewind Starter Assembly No. 590749 Tecumseh HMSK-80 155724X

Ref	Part No.	Qty.	Description				
●1	590599A	1	Spring Pin ASM				
●2	590600	1	Washer				
●3	590679	1	Retainer				
●4	590601	1	Washer				
●5	590678	1	Spring-Brake				
●6	590680	2	Dog-Starter				
●7	590412	2	Spring-Dog				
●8	590682	1	Pulley And Rewind Spring ASM				
●11	590750A	1	Starter Housing ASM				
●12	590535	1	Rope-Starter (98 Cut To Length)				
●13	590574	1	Handle-Starter, Mitten Grip				

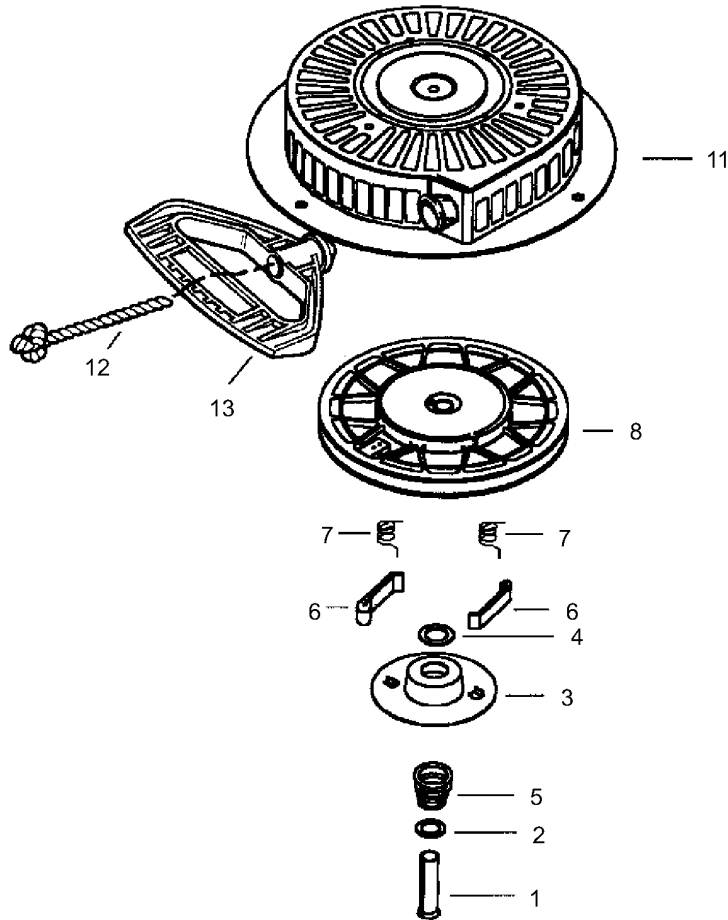

Rewind Starter Assembly No. 590733 (Optional) Tecumseh HMSK-80 155724X

Ref	Part No.	Qty.	Description				
1	590599A	1	Pin-Spring (Incl. Ref # 4)				
2	590600	1	Washer				
3	590696	1	Retainer				
4	590601	1	Washer				
5	590697	1	Spring-Brake				
6	590698	2	Dog-Starter				
7	590699	2	Spring-Dog				
8	590709	1	Pulley And Rewind Spring ASM				
11	590734A	1	Starter Housing ASM				
12	590535	1	Rope-Starter (98 Cut To Length)				
13	590574	1	Handle-Starter, Mitten Grip				

Attachments and Accessories

For 38631 - Power Max 828LXE Snowthrower

Product Name	Model/Part
Tire Chain Kit	107-3813
Snow Cab	107-3814
Weight Kit	107-3815
28 Inch Drift Breaker	107-3817

NOTES

