



## 60 Inch Side Discharge Mower Groundsmaster® 3320 and 3280-D

Model No. 30366 - 270000001 and up.

### Parts Catalog

---

#### Ordering Replacement Parts

To order replacement parts, please supply the part number, the quantity, and the description of each part desired.

#### Understanding Reference Numbers

Each identified part in an illustration has a reference number. The reference number for a part also appears in the parts list, along with other information about the part.

This catalog uses two special reference number formats, one to indicate parts in a service assembly and another to indicate the quantity of a given part in an illustration.

#### Service Assembly Reference Numbers

Parts in service assemblies have reference numbers in the form a:b. The a represents the reference number of the entire service assembly and the b represents a sequential number unique to each part within the service assembly.

For example, a wheel assembly might be identified by reference number 6, the tire by 6:1, the valve by 6:2, and the wheel by 6:3. When you order the assembly identified by reference number 6, you receive all parts identified by reference numbers 6:1, 6:2, and 6:3. However, you may also order any part individually. Reference numbers of this type appear in illustrations and in part lists.

#### Reference Numbers Indicating Quantity

In an illustration, if a reference number indicates more than one part, the reference number has the form nX y. The n represents the quantity of the part, the X is the multiplication symbol, and the y represents the reference number.

For example, in an illustration, the reference number 2X 37 means that two of the parts identified by reference number 37 are indicated.

# Contents

Description	Page	Description	Page
Deck, Roller, Belt and Pulley Assembly	..... 3	Rubber Deflector Assembly No. 108-2792	..... 9
Deck Assembly No. 107-7271	..... 4	Lever Assembly No. 107-1664	..... 10
Caster Arm Assembly	..... 5	Gearbox Assembly No. 108-1370	..... 11
Spindle and Blade Assembly	..... 6	Drive Shaft Assembly No. 110-4704	..... 12
Spindle Assembly No. 108-1957	..... 7	Lift Arm and Rear Height-of-Cut Assembly	..... 13
Cover, Gearbox, Drive Shaft and Baffle Assembly	..... 8	LH Lift Arm Assembly No. 108-1948	..... 14
		RH Lift Arm Assembly No. 108-1947	..... 15
		Attachments and Accessories List	..... 16

## Part Description Abbreviations

Part descriptions in this catalog may include the following abbreviations.

AR. .... as required	HYD. .... hydraulic
ASM. .... assembly	LH. .... left hand
BBC. .... blade brake clutch	NI. .... nylon insert
CARR. .... carriage	NPTF. .... national pipe thread fine
DEG. .... degrees	PFH. .... phillips flat head
EXT. .... external	PPH. .... phillips pan head
FH. .... flat head	PPHTF. .... phillips pan head thread forming
GA. .... gauge	PRH. .... phillips round head
HD. .... heavy-duty	PTH. .... phillips truss head
HF. .... hex flange	PTO. .... power-take-off
HH. .... hex head	RH. .... right hand
HHF. .... hex head flange	ROPS. .... roll-over protection system
HHFTF. .... hex head flange thread forming	SFH. .... slotted fillister head
HJ. .... hex jam	SHH. .... slotted hex head
HLH. .... hex lag head	SHWH. .... slotted hex washer head
HOC. .... height-of-cut	SPH. .... slotted pan head
HSBH. .... hex socket button head	SQH. .... square head
HSFH. .... hex socket flat head	SRH. .... slotted round head
HSH. .... hex socket head	STD. .... standard
HWH. .... hex washer head	TAP. .... self tapping
HWHTF. .... hex washer head thread forming	TTH. .... torx truss head

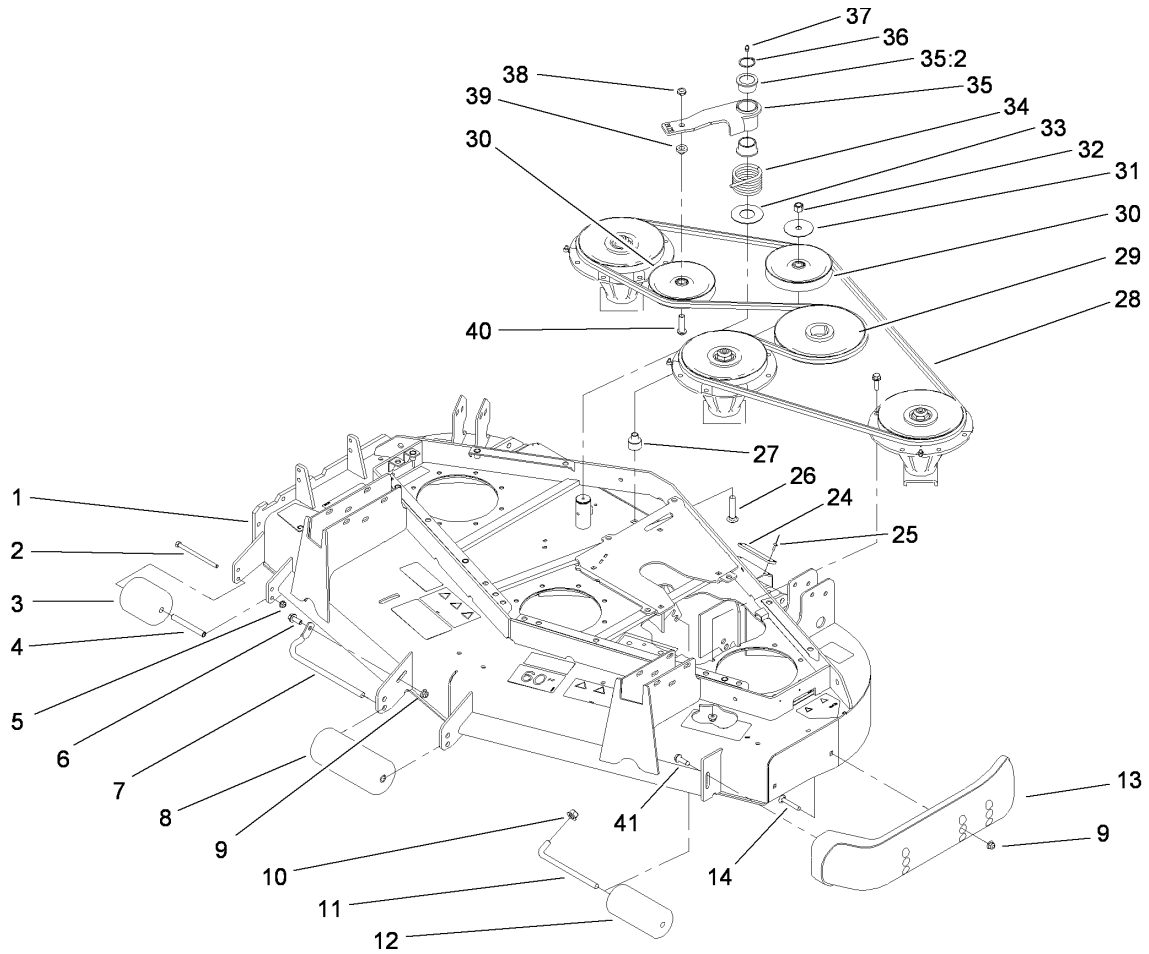

## Deck, Roller, Belt and Pulley Assembly

Ref	Part No.	Qty.	Description
1	107-7271	1	Deck ASM
2	322-29	1	Screw-HH
3	93-4803	1	Roller-Deck
4	105-4549	1	Spacer-Roller
5	104-8300	1	Nut-Flange, NI
6	3234-42	1	Screw-HHF
7	68-6840	1	Shaft-Roller
8	68-6710	1	Roller
9	104-8301	3	Nut-Flange, NI
10	99-5107	2	Nut-Lock
11	110-9683	2	Shaft-Rear Roller
12	36-1740	2	Roller-Deck
13	112-1479	1	Skid-Bumper, Deck
14	3231-33	2	Screw-CARR
24	108-1914	2	Pad-Bumper
25	3269-24	8	Rivet
26	3233-34	1	Screw-CARR
27	108-1908	1	Spacer-Idler
28	108-4391	1	Belt-Hex
29	108-1950	1	Pulley
30	01-268-0160	2	Pulley-Idler
31	100-3102	1	Washer-Flat
32	3296-23	1	Nut-Lock, NI
33	108-1926	1	Washer

Ref	Part No.	Qty.	Description
34	108-1921	1	Spring-Torsion
35	108-1930	1	Idler Arm ASM
35:2	93-4510	2	Bushing-Caster
36	32120-84	1	Ring-Snap, External
37	302-5	1	Fitting-Grease
38	3296-45	1	Nut-Lock, NI
39	108-1924	1	Spacer-Idler
40	108-1993	1	Screw-HSBH
41	9136144	1	Screw-HWHTF



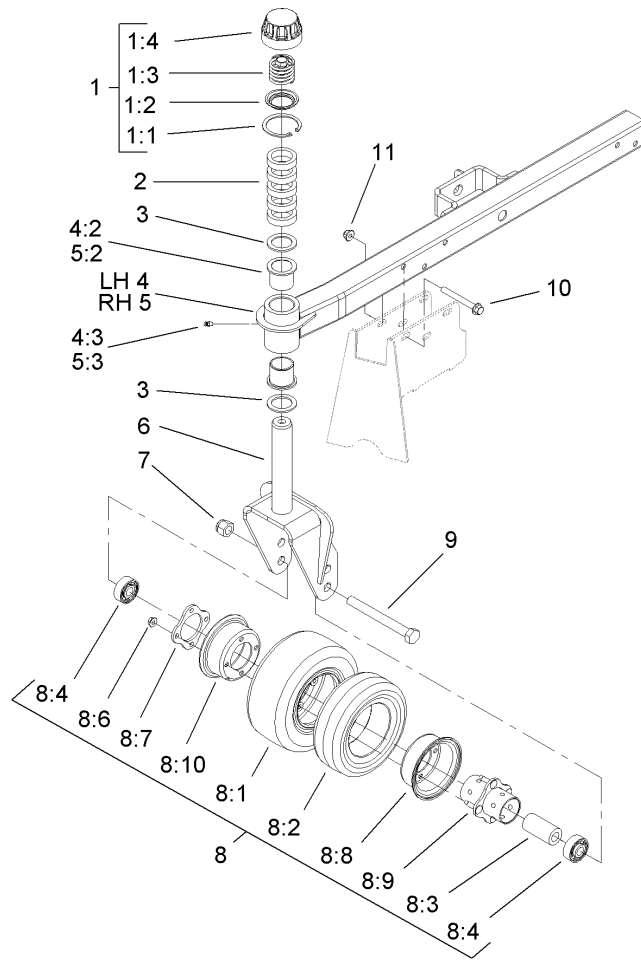

## Caster Arm Assembly

Ref	Part No.	Qty.	Description
1	92-9727	2	HOC Cap ASM
1:1	92-5581	1	Ring-Retaining
1:2	92-5583	1	Washer-Cap
1:3	92-9726	1	Spring-Compression
1:4	92-8861	1	Cap-HOC
2	69-1510	10	Spacer-Caster
3	69-6860	4	Washer-Thrust
4	108-5744	1	LH Caster Arm ASM
4:2	69-6470	2	Bushing-Caster
4:3	302-5	1	Fitting-Grease
5	108-5745	1	RH Caster Arm ASM
5:2	69-6470	2	Bushing-Caster
5:3	302-5	1	Fitting-Grease
6	104-0762-01	2	Caster Fork ASM
7	3296-53	2	Nut-Lock, NI
8	93-9938	2	8 Inch Wheel ASM
8:1	93-9939	1	Tire
8:2	68-8950	1	Tube-Inner (W/Valve)
8:3	93-4241	1	Spacer-Bearing, Inner
8:4	93-4237	2	Bearing
8:6	32128-16	4	Nut-HHF
8:7	93-4242	1	Plate
8:8	93-4239	1	Rim-Wheel, Half
8:9	93-5980	1	Hub

Ref	Part No.	Qty.	Description
8:10	95-2741	1	Rim-Wheel, Half
9	327-24	2	Screw-HH
10	3234-41	10	Screw-HHF
11	104-8301	10	Nut-Flange, NI

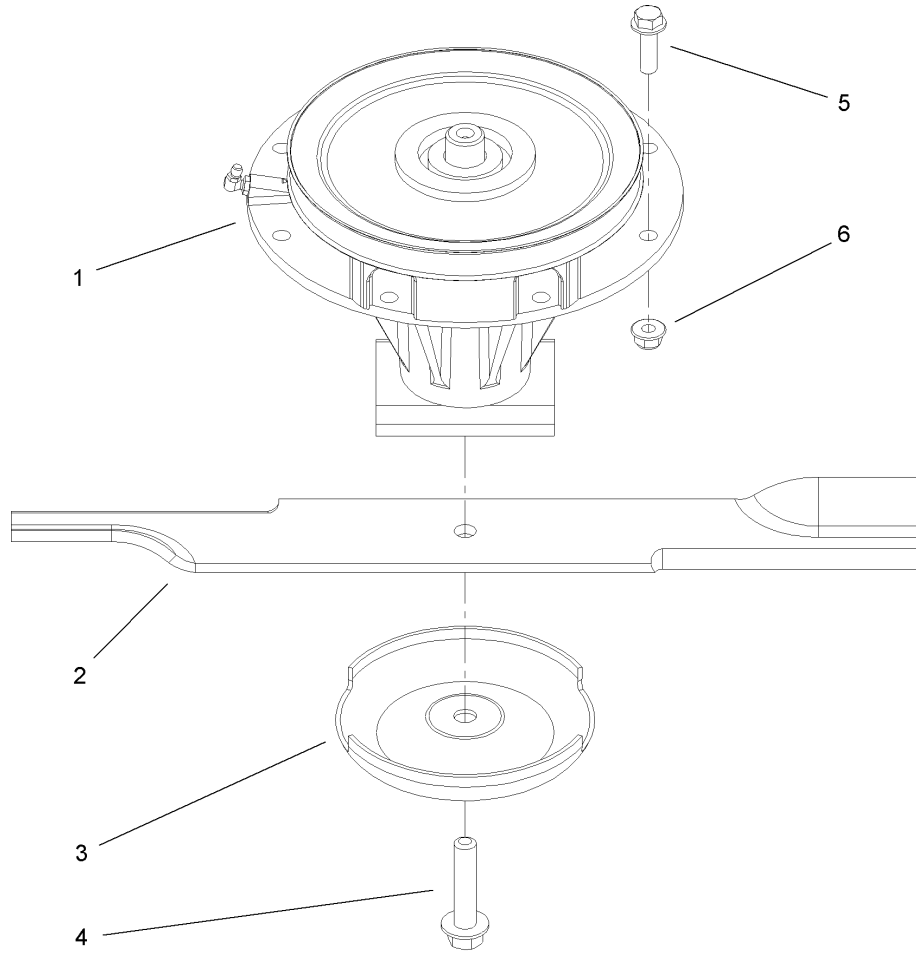

### Spindle and Blade Assembly

Ref	Part No.	Qty.	Description				
1	108-1957	3	Spindle ASM				
2	110-4701	3	Blade-Rotary, 20.5 Med Flow				
3	72-9361	3	Cup-Scalp, Anti				
4	92-5816	3	Bolt-Blade				
5	3234-24	24	Screw-HHF				
6	104-8301	24	Nut-Flange, NI				

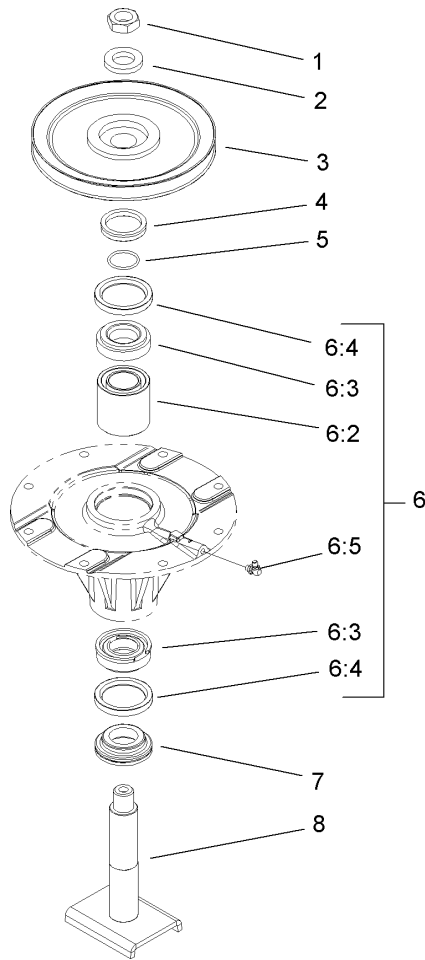

## Spindle Assembly No. 108-1957

Ref	Part No.	Qty.	Description				
1	3296-60	1	Nut-Lock, NI				
2	104-8322	1	Washer-Hardened				
3	104-3546	1	Pulley-Driven, Low				
4	104-3564	1	Seal-V Ring				
5	106-7159	1	O-Ring				
6	108-1991	1	Spindle Housing ASM				
6:2	108-1954	1	Spacer Set-Bearing				
6:3	26-1830	1	Bearing Kit (Matched Set)				
6:4	253-154	2	Seal-Oil				
6:5	302-60	1	Fitting-Grease, 90 DEG				
7	69-6950	1	Spacer-Shaft, Spindle				
8	108-1956	1	Shaft ASM				

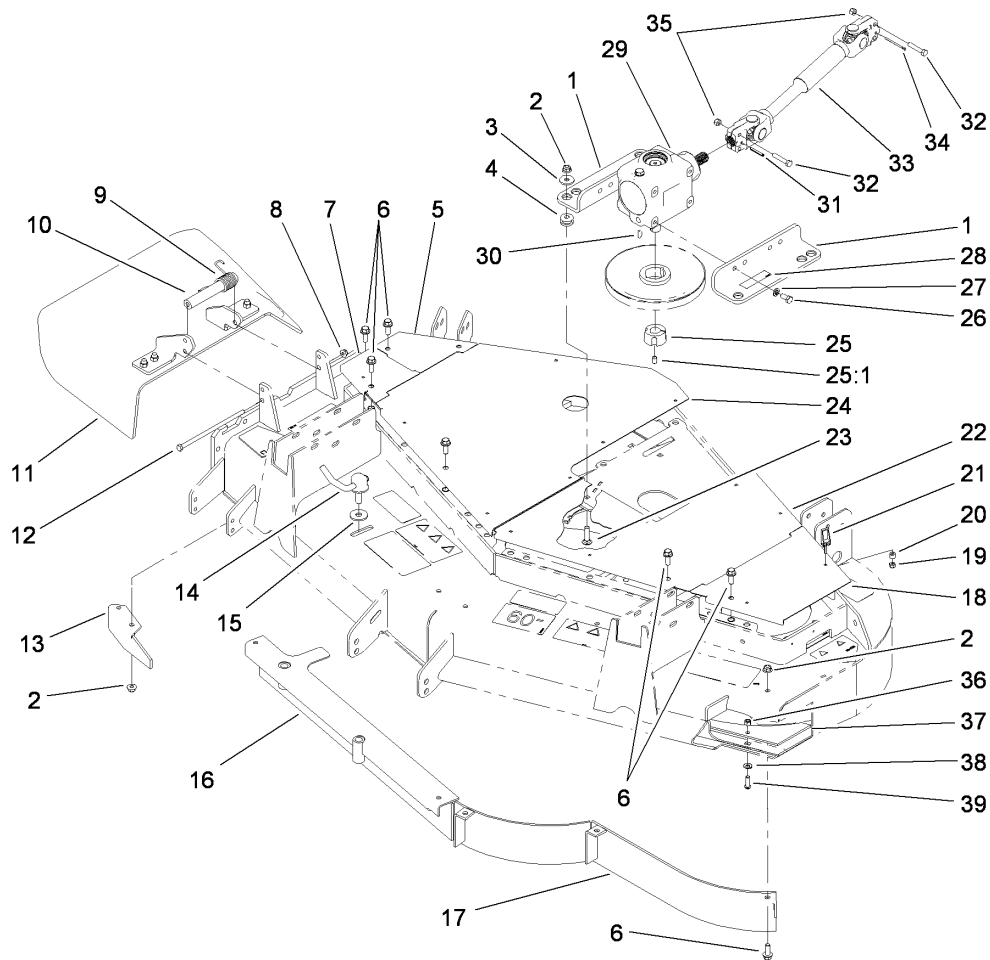

## Cover, Gearbox, Drive Shaft and Baffle Assembly

Ref	Part No.	Qty.	Description
1	108-4376-03	2	Bracket-Gearbox
2	104-8301	10	Nut-Flange, NI
3	63-8410	4	Washer
4	63-9750	4	Mount
5	108-6064-03	1	Cover-Outside, Rear (RH)
6	3234-42	12	Screw-HHF
7	108-6065-03	1	Cover-Outside, Front (RH)
8	104-8300	1	Nut-Flange, NI
9	108-4052	1	Spring-Torsion
10	105-4622	1	Spacer
11	108-2792	1	Rubber Deflector ASM
12	322-50	1	Screw-HH
13	106-3216-01	1	Baffle-Discharge
14	107-1664	2	Lever ASM
15	105-7697	2	Washer-Plastic
16	105-7669-01	1	Baffle ASM
17	105-7657-01	1	Baffle ASM
18	108-6068-03	1	Cover-Outside, LH
19	1-804254	16	Nut
20	106-6778	16	Bushing-Latch, Swell
21	106-6777	16	Handle-Latch, Swell
22	108-6067-03	1	Cover-Middle, LH
23	3231-26	4	Screw-CARR
24	108-6066-03	1	Cover-Middle, RH

Ref	Part No.	Qty.	Description
25	23-1640	1	Bushing-Taperlock
25:1	3247-4	2	Screw-Set
26	323-4	4	Screw-HH
27	3253-21	4	Washer-Lock
28	93-6697	1	Decal-Lube
29	108-1370	1	Gearbox Replacement Kit
30	3257-5	1	Key-Woodruff
31	32121-34	1	Pin-Roll
32	322-9	4	Screw-HH
33	110-4704	1	PTO Drive Shaft ASM
34	3272-15	1	Pin-Cotter
35	3296-29	4	Nut-Lock, NI
36	3296-29	2	Nut-Lock, NI
37	107-3137	1	Plate-Turbo
38	1-303334	2	Washer-Spring
39	3274-104	2	Screw-HSBH





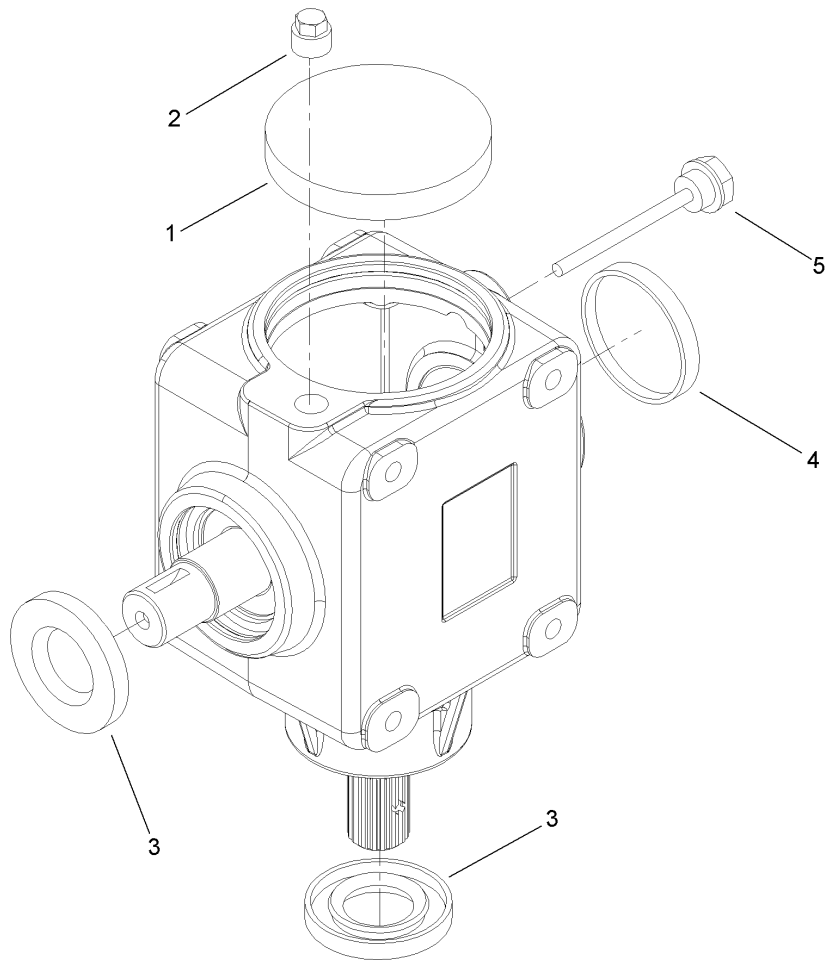

### Gearbox Assembly No. 108-1370

Ref	Part No.	Qty.	Description	
1	107-2932	1	Cap-Oil	
2	107-2933	1	Plug	
3	107-2934	2	Seal-Oil	
4	107-2935	1	Cap-Oil	
5	107-2936	1	Plug-Filler, Dipstick	



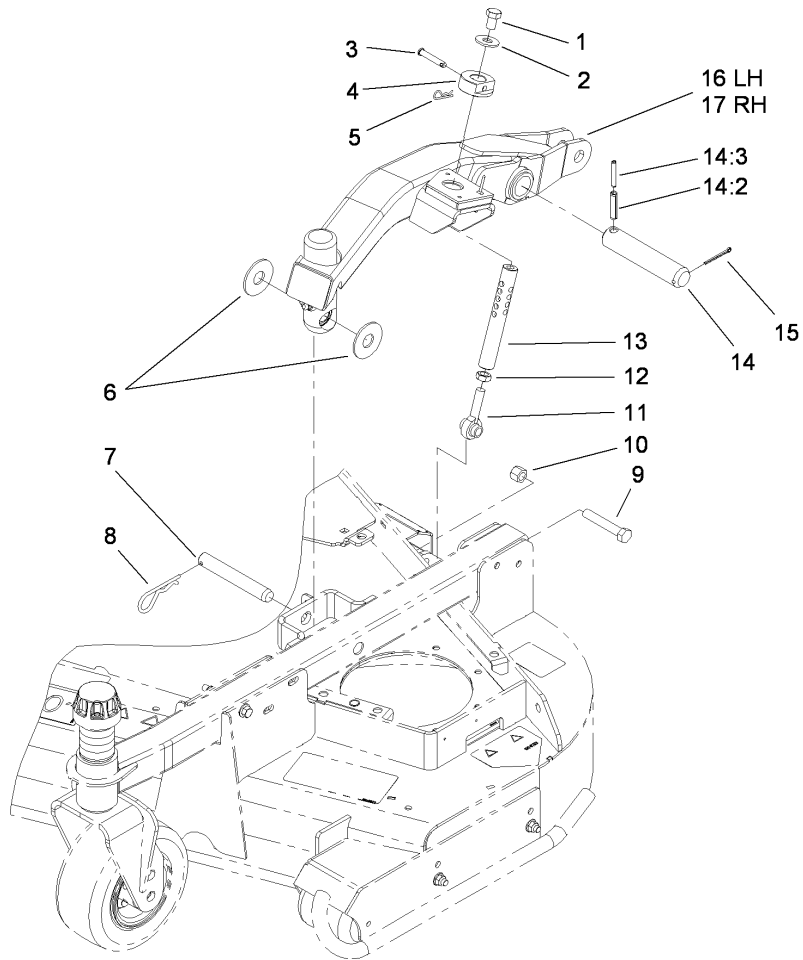

### Lift Arm and Rear Height-of-Cut Assembly

Ref	Part No.	Qty.	Description				
1	3213-20	2	Screw-HH				
2	3256-6	2	Washer-Flat				
3	107-3457	2	Pin-Clevis				
4	110-0641	2	Collar-HOC				
5	3290-467	2	Pin-Hair				
6	107-7915	4	Washer-Thrust				
7	107-7904	2	Pin-Clevis				
8	3290-256	2	Pin-Hair				
9	325-12	2	Screw-HH				
10	3296-45	2	Nut-Lock, NI				
11	105-2808	2	End-Rod				
12	3220-5	2	Nut-Jam				
13	107-7284	2	Tube-HOC				
14	98-2330	2	Pivot Pin ASM				
14:2	32121-67	1	Pin-Roll				
14:3	32121-61	1	Pin-Roll				
15	3272-24	2	Pin-Cotter				
16	108-1948	1	LH Lift Arm ASM				
17	108-1947	1	RH Lift Arm ASM				





# Attachments and Accessories

For 30366 - 60in Side Discharge Mower, Groundsmaster 3320 and 3280-D

Product Name	Model/Part
High-Speed Blade Tip Kit .....	108-1960
Leaf Mulching Kit .....	108-5272
Blade-Rotary, 20.5 High Flow .....	110-4702-03
Blade-Rotary, 20.5 Atomic .....	110-4703-03
Castor Wheel ASM Kit .....	110-4767
60 Inch SDD Blade And Belt Kit .....	110-4770
8 Inch Foam Filled Wheel ASM .....	93-5974

# NOTES

# NOTES

# NOTES

