



Hour Meter Kit for TRX Trenchers

Model No. 115-4028

Installation Instructions

Installing the Hour Meter

1. Park the machine on a level surface, stop the engine, lower the boom, remove the key, and allow the engine to cool.
2. Punch or cut out the knock-out plate covering the opening for the hour meter, located next to the ignition switch.
3. Remove the retainer from the hour meter (Figure 1).

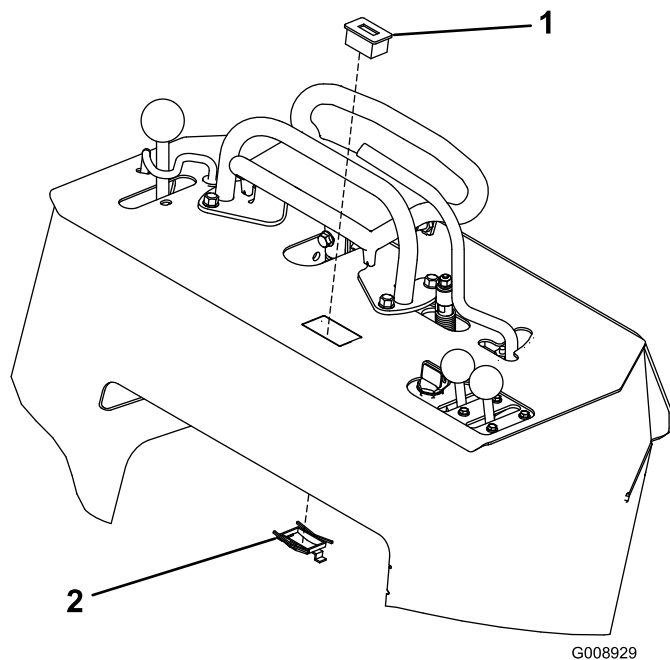

Figure 1

1. Hour meter
2. Retainer

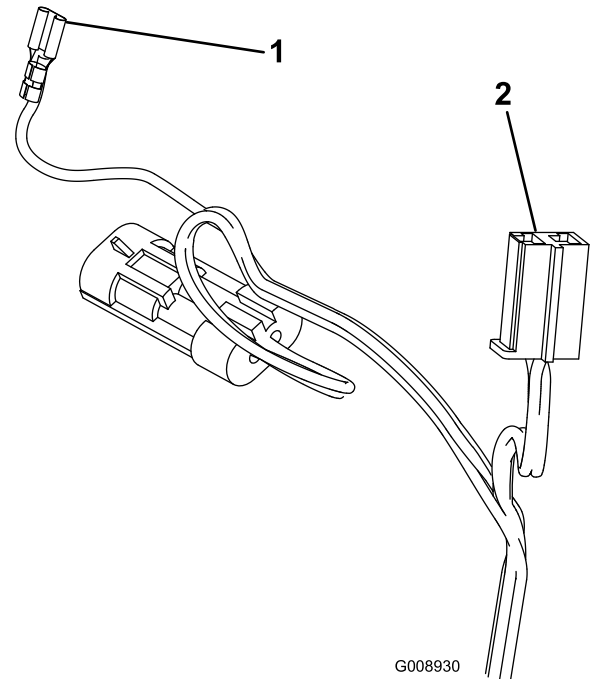

Figure 2

1. Loose connector
 2. Connector attached to the ignition switch
-
6. Remove the protective cover from the spade connector and slide it all the way onto the blade connector on the bottom of the hour meter.

4. Slide the hour meter into the control panel and then snap the retainer onto it from below to secure it (Figure 1).
5. Locate the wire harness leading from the bottom of the ignition switch. Nearby will be a loose spade connector (Figure 2).