



**Count on it.**

**Operator's Manual**

**QAS Bunker Pump**

**Sand/Infield Pro 3040 and 5040 Traction Unit**

**Model No. 08765—Serial No. 280000001 and Up**

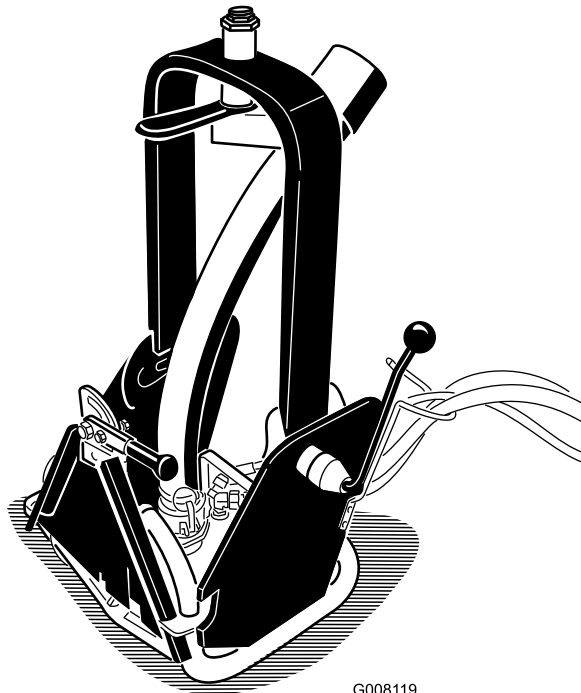

G008119

# Introduction

Read this information carefully to learn how to operate and maintain your product properly and to avoid injury and product damage. You are responsible for operating the product properly and safely.

You may contact Toro directly at [www.Toro.com](http://www.Toro.com) for product and accessory information, help finding a dealer, or to register your product.

Whenever you need service, genuine Toro parts, or additional information, contact an Authorized Service Dealer or Toro Customer Service and have the model and serial numbers of your product ready. Figure 1 identifies the location of the model and serial numbers on the product. Write the numbers in the space provided.

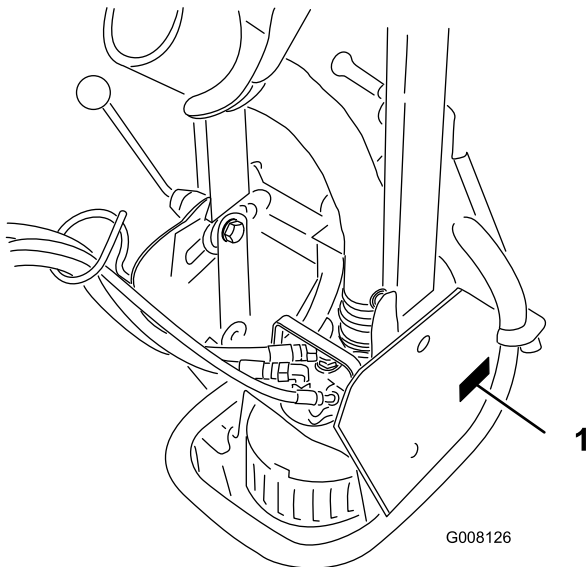

**Figure 1**

1. Model and serial number location

<b>Model No.</b> _____
<b>Serial No.</b> _____

This manual identifies potential hazards and has safety messages identified by the safety alert symbol (Figure 2), which signals a hazard that may cause serious injury or death if you do not follow the recommended precautions.



**Figure 2**

1. Safety alert symbol

This manual uses 2 other words to highlight information. **Important** calls attention to special mechanical information and **Note** emphasizes general information worthy of special attention.

## Contents

Introduction.....	2
Safety .....	3
Before Operating .....	3
While Operating.....	3
Maintenance.....	3
Safety and Instructional Decals .....	4
Setup.....	5
1 Mounting the Bunker Pump to the Traction Unit.....	5
2 Adjusting the Link Assembly.....	6
Operation.....	7
Adjusting the Discharge Nozzle.....	7
Before Operating .....	7
Operating the Bunker Pump .....	8
Operating Tips .....	8
Maintenance.....	10
Pump Cleaning.....	10

# Safety

Hazard control and accident prevention are dependent upon the awareness, concern, and proper training of the personnel involved in the operation, transport, maintenance, and storage of the machine. Improper use or maintenance of the machine can result in injury or death. To reduce the potential for injury or death, comply with the following safety instructions.

## Before Operating

- Read and understand the contents of this Operator's Manual and the Sand Pro Operator's Manual before operating the machine. Become familiar with all of the controls and know how to stop quickly. A free replacement manual is available by sending the complete Model and Serial Number to The Toro® Company, 8111 Lyndale Avenue South, Bloomington, Minnesota 55420-1196.
- Never allow children to operate the machine. Do not allow adults to operate machine without proper instruction. Only trained operators who have read this manual should operate this machine.
- Never operate the machine when under the influence of drugs or alcohol.
- Keep all bystanders away from the operating area.
- Keep all shields and safety devices in place. If a shield, safety device, or decal is illegible or damaged, repair or replace it before operation is commenced. Also tighten any loose nuts, bolts, and screws to ensure that the machine is in safe operating condition.
- Do not operate the machine while wearing sandals, tennis shoes, sneakers, or shorts. Also, do not wear loose fitting clothing which could get caught in moving parts. Always wear long pants and substantial shoes. Wearing safety glasses, safety shoes, and a helmet is advisable and required by some local ordinances and insurance regulations.

## While Operating

- Do not run the engine in a confined area without adequate ventilation. Exhaust fumes are hazardous and could possibly be deadly.
- The maximum seating capacity is one person. Never carry passengers.
- Sit on the seat when starting the engine and operating the machine.

- Using the machine demands attention. To prevent loss of control:
  - Operate only in daylight or when there is good artificial light.
  - Drive slowly and watch for holes or other hidden hazards.
  - Use extreme caution when driving into a sand trap, ditch, creek, or other hazard.
  - Reduce your speed when making sharp turns and when turning on hillsides.
  - Avoid sudden starts and stops.
  - Before backing up, look to the rear and ensure that no one is behind the machine.
  - Watch out for traffic when near or crossing roads. Always yield the right-of-way.
- Stay away from the discharge opening when the machine is operating. Keep all bystanders away from the discharge opening and don't direct discharge toward bystanders.
- If the engine stalls or the machine loses headway and cannot make it to the top of a slope, do not turn the machine around. Always back slowly straight down the slope.
- **Do not take an injury risk!** When a person or pet appears unexpectedly in or near the operating area, **stop operation.** Careless operation, combined with terrain angles, ricochets, or improperly positioned guards can lead to thrown object injuries. Do not resume operation until the area is cleared.
- Do not touch the engine or muffler while the engine is running or soon after it is stopped. These areas could be hot enough to cause a burn.

## Maintenance

- Remove the key from the ignition switch to prevent accidental starting of the engine when servicing, adjusting, or storing the machine.
- Perform only those maintenance instructions described in this manual. If major repairs are ever needed or assistance is desired, contact an Authorized Toro Distributor.
- To reduce a potential fire hazard, keep the engine free of excessive grease, grass, leaves, and accumulations of dirt. Never wash a warm engine or any electrical parts with water.
- Be sure that the machine is in safe operating condition by keeping nuts, bolts, and screws tight.

- Make sure that all hydraulic line connectors are tight and all hydraulic hoses and lines are in good condition before applying pressure to the system.
- Keep your body and hands away from pin hole leaks in hydraulic lines that eject high pressure hydraulic fluid. Use cardboard or paper to find hydraulic leaks. Hydraulic fluid escaping under pressure can penetrate skin and cause injury. Fluid accidentally injected into the skin must be surgically removed within a few hours by a doctor familiar with this form of injury or gangrene may result.
- Before disconnecting or performing any work on the hydraulic system, all pressure in the system must be relieved by stopping the engine and lowering the pump to the ground.
- If the engine must be running to perform a maintenance adjustment, keep hands, feet, clothing, and other parts of the body away from the fan and other moving parts.
- Do not overspeed the engine by changing the governor settings. To be sure of safety and accuracy, have an Authorized Toro Distributor check the maximum engine speed with a tachometer.
- The engine must be shut off before checking the oil or adding oil to the crankcase.
- To ensure optimum performance and safety, always purchase genuine Toro replacement parts and accessories to keep the machine all Toro. **Never use “will-fit” replacement parts and accessories made by other manufacturers.** Look for the Toro logo to ensure genuineness. Using unapproved replacement parts and accessories could void the warranty.

## Safety and Instructional Decals



Safety decals and instructions are easily visible to the operator and are located near any area of potential danger. Replace any decal that is damaged or lost.

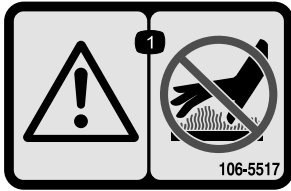

**106-5517**

1. Warning—do not touch the hot surface.

# Setup

## Loose Parts

Use the chart below to verify that all parts have been shipped.

Procedure	Description	Qty.	Use
<b>1</b>	Bunker pump assembly	1	Mount the bunker pump to the traction unit
<b>2</b>	No parts required	–	Adjust the link assembly

## Media and Additional Parts

Description	Qty.	Use
Parts catalog	1	
Operator's Manual	1	Read before operating the machine

**Note:** Determine the left and right sides of the machine from the normal operating position.

**Note:** To operate the bunker pump, the traction unit must be equipped with the Rear Remote Hydraulics Kit, Model 08781 or the Front Remote Hydraulics Kit, Model 08782.

# 1

## Mounting the Bunker Pump to the Traction Unit

### Parts needed for this procedure:

1	Bunker pump assembly
---	----------------------

### Procedure

1. Remove any attachment from the machines traction unit adapter.
2. Move the traction unit into position behind the attachment adapter.

**Note:** Make sure the locking lever (Figure 3) is pivoted to the left (unlocked position) as viewed from the rear of the machine.

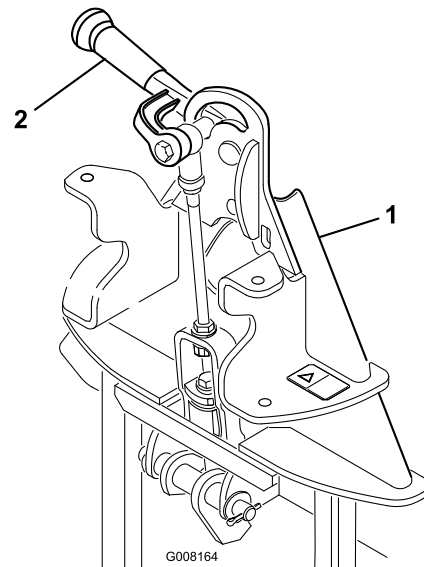

**Figure 3**

1. Attachment adapter      2. Locking lever

3. Raise the traction unit adapter into the attachment adapter.
4. Pivot the locking lever to the right to lock the adapters together.
5. Make sure the engine and the remote hydraulics kit are OFF.
6. Plug the hydraulic hoses into the Sand Pro remote hydraulics. Position the hoses in the hose guide (Figure 4). Avoid kinks and sharp bends to the hydraulic hoses.

# 2

## Adjusting the Link Assembly

### No Parts Required

### Procedure

1. With the bunker pump mounted and secured on the traction unit, raise the attachment.
2. Measure the gap between the top washer and the spacer in the link assembly on the attachment adapter as shown in Figure 5.

**Note:** The gap between the washer and the shoulder should be 0.060 to 0.080 inch

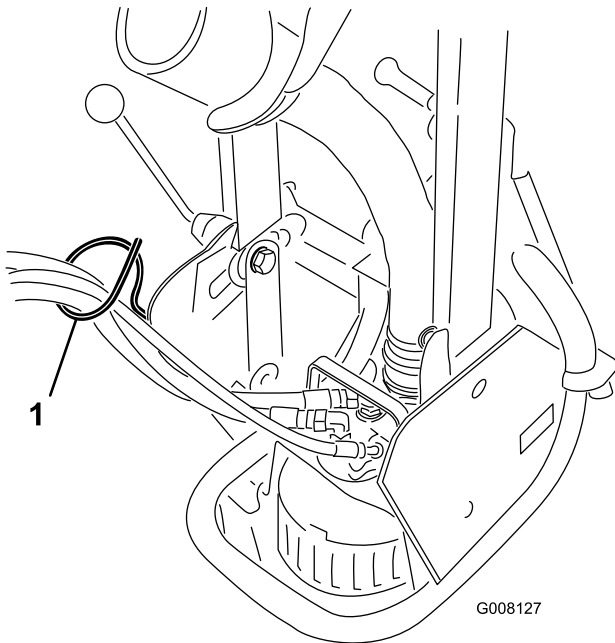

Figure 4

1. Hose guide

---

**Important:** Whenever the hydraulic hose couplers are disconnected, make sure the dust plugs are installed to prevent contamination from entering either hydraulic system.

7. During operation the bunker pump hydraulic hoses will displace a small amount of the traction unit's hydraulic oil. Check the hydraulic oil level in the traction unit as follows:
  - A. Start the traction unit engine and the remote hydraulics.
  - B. Start the bunker pump and allow it to run a few seconds. It does not have to be submerged in water.
  - C. Stop the pump, the remote hydraulics and the engine.
  - D. Check the hydraulic oil level in the traction unit and replenish as required. Refer to Traction Unit Operator's Manual for hydraulic oil requirements.

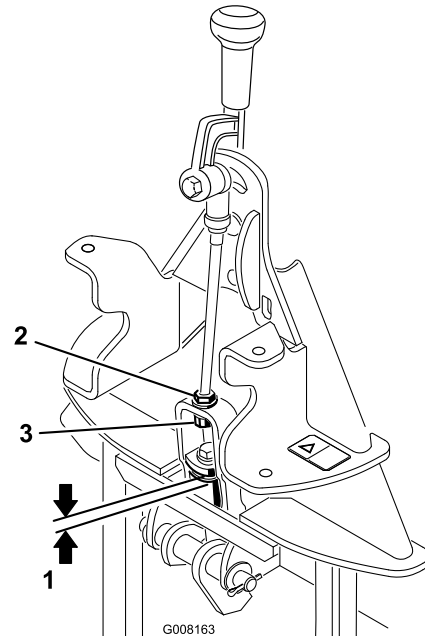

Figure 5

1. 0.060 to 0.080 inch
2. Jam nut
3. Adjustment nut

# Operation

## Adjusting the Discharge Nozzle

The discharge nozzle (Figure 6) can be adjusted up and down or from side to side to direct the flow to the desired location.

1. To adjust the flow distance, proceed as follows
  - Rotate the lockup handle (Figure 6) to unlock the pivot tower.

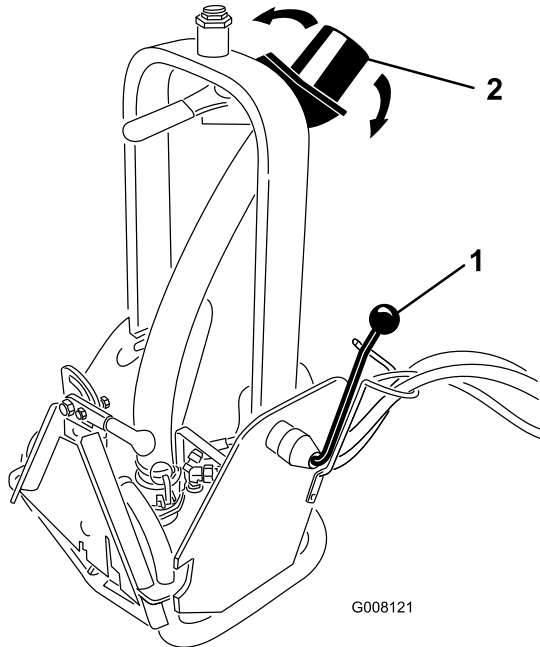

Figure 6

1. Lockup handle                      2. Discharge nozzle

- Rotate the pivot tower front or back to the desired position.
- Tighten the lockup handle.

**Note:** When the pump is mounted to the **front** of the machine, the lockup handle should be removed and reinstalled on the opposite side of the frame.



**Do not move the lockup handle to the opposite side of the frame when the pump is mounted to the rear of the machine.**

2. To adjust the flow direction, rotate the nozzle handle (Figure 7) to the desired position.

**Note:** The resistance on the handle nozzle (Figure 7) may be increased or decreased by

adjusting the torque on the large nut on top of the pivot tower.

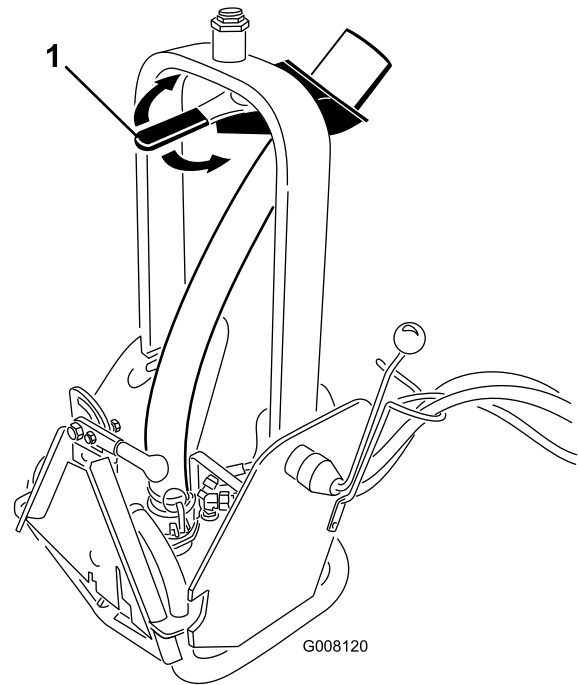

Figure 7

1. Nozzle handle

## Before Operating

1. Measure the water depth in the lowest part of the bunker. If the water depth is less than 2-1/2 inches (halfway up the slots on the pump), dig a 1 foot by 1 foot by 2-3 inch deep hole to lower the pump into the hole (Figure 8).

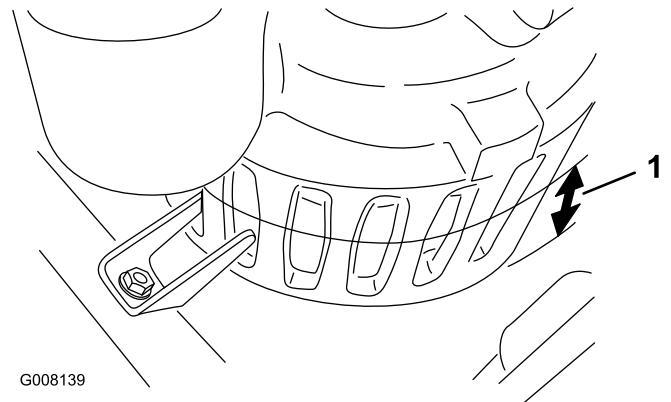
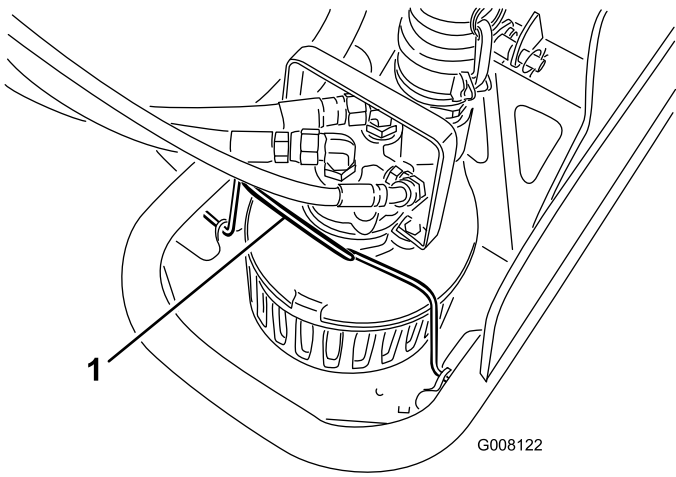

Figure 8

1. Water level (2-1/2 inches)

2. Make sure the pump clamp (Figure 9) and the lockup handle (Figure 10) are secure before commencing operation.



**Figure 9**

1. Pump clamp

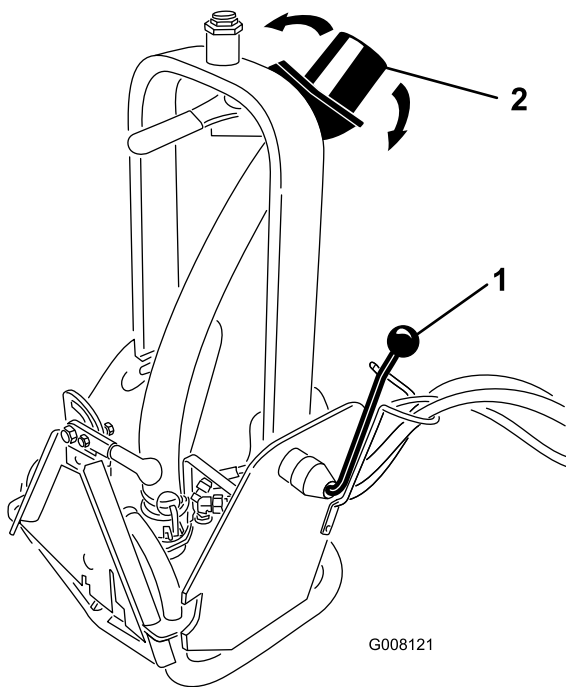

**Figure 10**

1. Lockup handle
2. Discharge nozzle

3. Check and adjust the pump discharge direction. Refer to Adjusting the Discharge Nozzle.

## Operating the Bunker Pump

1. Start the Sand Pro and slowly back into the shallowest part of the bunker. Do not drive into water that is deeper than the wheel hubs of the Sand Pro (Figure 11).

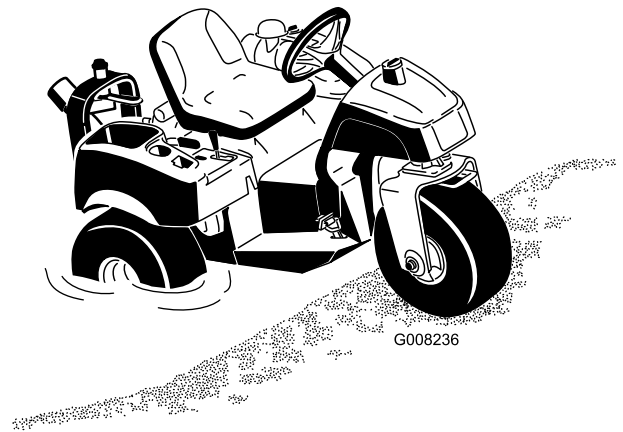

**Figure 11**

**Note:** If the Sand Pro cannot be moved into the desired position, the pump can be removed from the housing and placed into the water. To remove the pump, pivot the pump clamp forward, slide the pump to the rear of the frame and lift the pump out with the handle.

2. Start the remote hydraulics to activate the pump before inserting the pump into the water. This prevents debris from stalling the pump impeller to the housing if debris gets lodged in the pump.
3. Lower the pump into the water.

**Note:** If the pump does not start pumping once it is in the water, cycle the remote hydraulics on for 1 second and off for 2 seconds to help the pump prime.

4. Check the flow and redirect as required.

## Operating Tips



**Discharged output has considerable force and could cause injury or loss of footing.**

- Stay away from discharge nozzle when machine is operating.
- Keep bystanders away from discharge nozzle when machine is running.

- Make sure nozzle collar is free of debris so it drains properly.
- Do not use the bunker pump in salt water.

**Note:** If the attachment adapter becomes stuck to the traction unit adapter, insert a pry bar/screwdriver into the pry slot to disengage the parts (Figure 12).

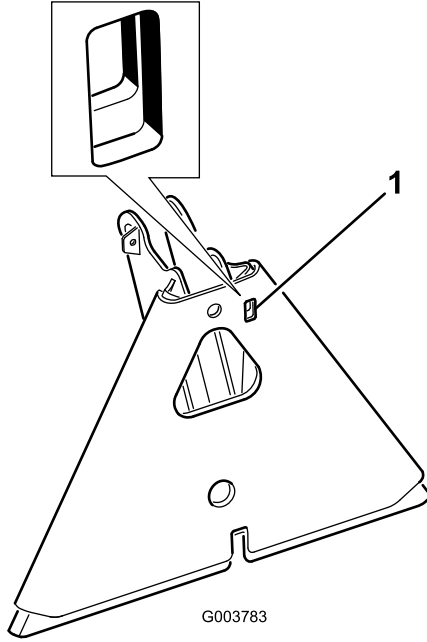

**Figure 12**

1. Pry slot

---

# Maintenance

## Pump Cleaning

If foreign matter gets into the bunker pump, the flow may decrease or stop. If this occurs, the pump will have to be removed from the frame, disassembled, cleaned, reassembled and installed back into the frame.

1. Stop the Sand Pro, apply the parking brake and remove the key from the ignition switch.
2. Disconnect the pump hydraulic hoses from the traction unit. Insert dust caps onto the exposed hydraulic couplers.
3. Release the latches and uncouple the discharge hose from the pump (Figure 13).

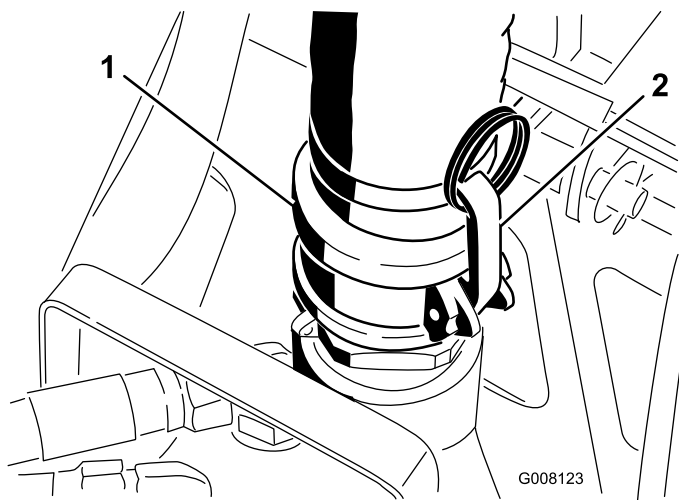

Figure 13

1. Discharge hose
2. Latch

4. Pivot the pump clamp forward (Figure 14).

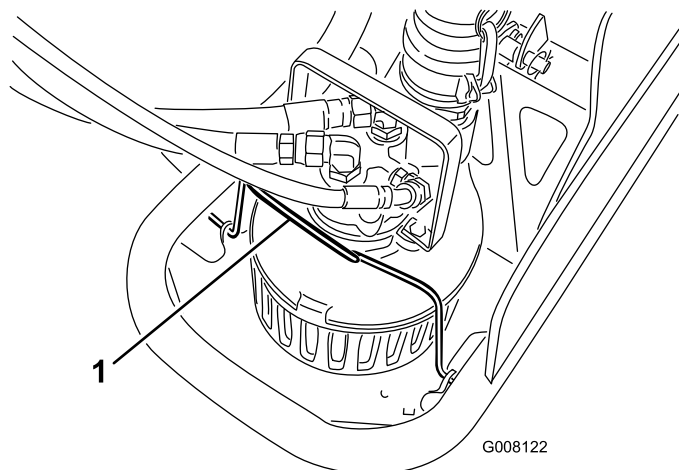

Figure 14

1. Pump clamp

5. Slide the pump to the rear of the frame and lift the pump out with the handle.

### Disassembly (Figure 15)

6. Remove the (5) cover plate mounting screws and remove the cover.
7. Try to turn the impeller to free any debris from the pump impeller and housing. If the debris cannot be freed, proceed to the next step.
8. Remove the (3) screws securing the suction flange and remove the suction flange.
9. Remove the (2) handle screws and remove the handle.
10. Remove the (4) hydraulic motor screws and remove the hydraulic motor cover, gerotor element with drive pin, and the thrust plate.
11. While holding the impeller, unthread the impeller from the shaft using a wrench on the flats at the ball bearing. The thread is a left hand thread that requires opposite rotation for removal.
12. Remove the shaft and bearing assembly by first removing the retaining ring, then apply pressure to slide the shaft and bearing out of the motor side of the pump housing.
13. Remove the (2) lip seals by pushing the seals out through the motor side of the pump body.

### Inspect the pump components

- Clean all foreign material off the parts. DO NOT use abrasive cleaning methods on the hydraulic parts or shaft.
- Check the motor shaft for wear at the lip seal surface. If it has grooves greater than .003 inches deep, the shaft should be replaced.
- Check the hydraulic motor parts for wear. Any appearance of displaced metal or surface smearing will require replacing all of the motor parts.
- Check the impeller blade surface between the impeller and the suction flange. If the surfaces are severely worn, or the impeller blades are bent, replace each item.
- Clean the parts that are to be reused using a solvent or mild cleaner. Remove abrasive material. Cleanliness of the hydraulic motor parts is very important.

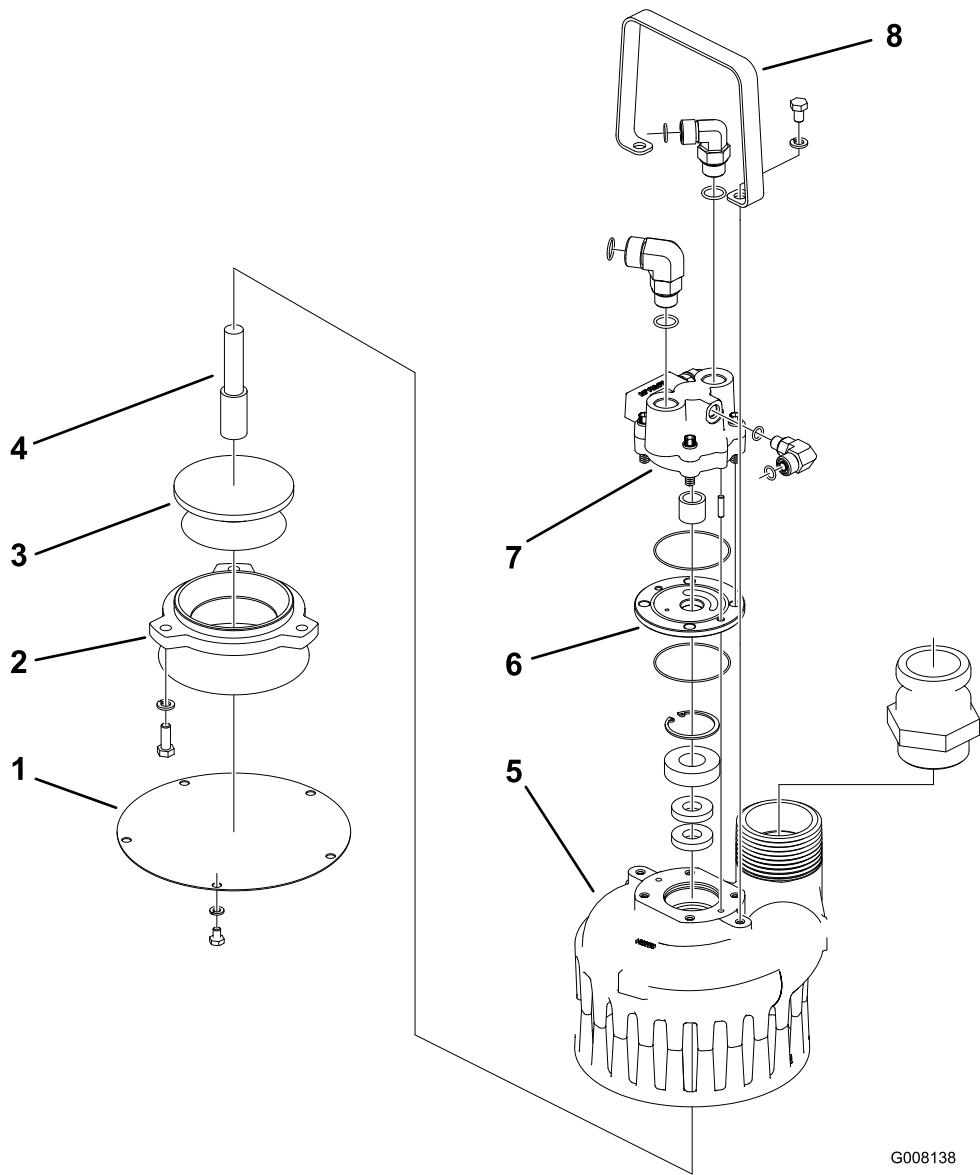

G008138

**Figure 15**

- |                   |             |                 |                    |
|-------------------|-------------|-----------------|--------------------|
| 1. Cover plate    | 3. Impeller | 5. Pump housing | 7. Hydraulic motor |
| 2. Suction flange | 4. Shaft    | 6. Thrust plate | 8. Handle          |

**Reassembly (Figure 15)**

1. Press the new lip seals into the pump housing using a suitable bushing or socket. A light lubricant may be used to aid the assembly. The proper assembly is to install the seals back to back, installing one seal at a time.
2. Press the new ball bearing onto the shaft by pressing against the inner face of the bearing until it is seated against the shaft shoulder. The first lip seal should be installed open face down and flat side facing out. The second lip seal should be installed flat side in.
3. Lubricate the impeller side of the shaft with oil. Push the shaft/bearing into the body using care to align the shaft at the center of the lip seal until it is at the bottom of the shoulder in the body. Install the snap ring to secure the shaft assembly.
4. Secure the shaft with a wrench on the flats of the shaft and thread the impeller onto the shaft (note left hand thread). Tighten the impeller until it shoulders onto the shaft.
5. Place new quad rings onto the thrust plate. Use a small amount of grease to hold the quad rings from moving out of position. Place the thrust plate over the shaft with the kidney slot up away from the bearing. Kidney should be on the pressure side of the motor.
6. Place the drive pin onto the shaft slot and hold it in position with a screwdriver while sliding the gerotor

over the shaft and stopping at the thrust plate. Line up the gerotor and thrust plate.

7. Install the cover onto the shaft; some sideways movement of the gerotor is necessary. The dowel pins should go through the thrust plate and into the body. Do not force this assembly by using a hammer or press, it will slide together when it is in position.
8. Install the four motor cover screws and torque to 17-ft.lbs in a cross pattern with the first torque @ 10-ft.lbs.
9. Install the suction flange and screws.
10. Install the handle and screws.
11. Check for free rotation by rotating the impeller by hand. If it does not rotate, remove the motor cover, clean the motor parts, and reassemble. Dust and dirt granules will impede motor rotation.
12. Install the cover plate using five screws and lockwashers.
13. Insert the pump into the frame and slide it forward until the keeper tab fits into the slots of the pump (Figure 16).

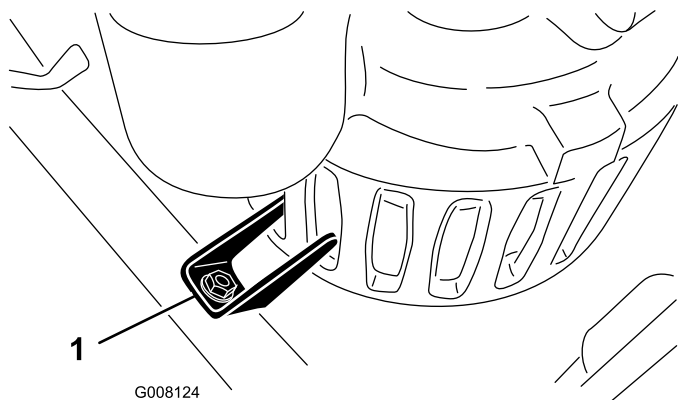

**Figure 16**

1. Keeper tab

14. Pivot the pump clamp rearward onto the pump (Figure 14).
15. Couple the discharge hose to the pump and secure the latches (Figure 13).
16. Connect the hydraulic hoses to the traction unit.

## Checking the Nozzle Sleeve

The nozzle sleeve (Figure 17) in the handle assembly is slotted to allow water and debris to drain without back flowing into the hose. Make sure the slot and hole are free of debris.

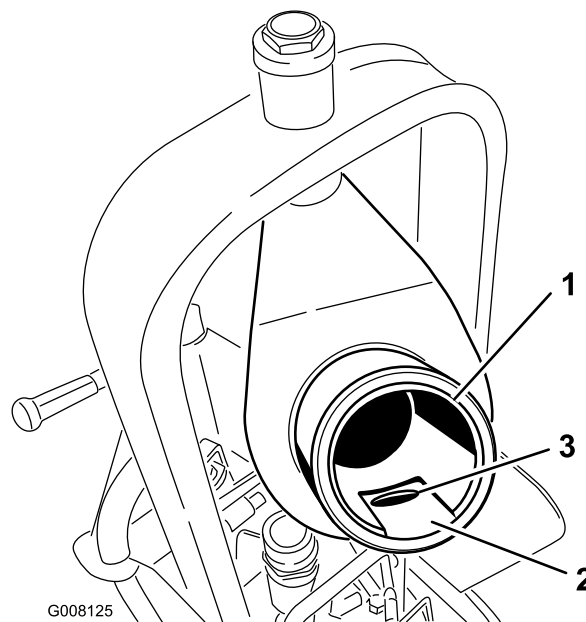
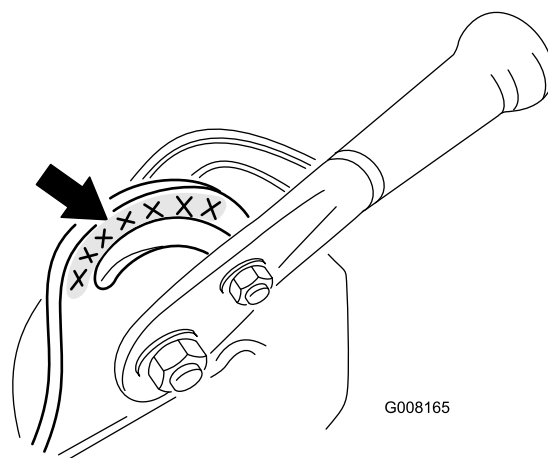

**Figure 17**

1. Nozzle sleeve
2. Slot
3. Hole

## Greasing the Attachment Adapter

If the locking lever on the attachment adapter does not pivot freely and easily, apply a light coat of grease to the area shown in Figure 18.



**Figure 18**

**Notes:**

**Notes:**

**Notes:**



## Toro General Commercial Products Warranty

### A Two-Year Limited Warranty

#### Conditions and Products Covered

The Toro Company and its affiliate, Toro Warranty Company, pursuant to an agreement between them, jointly warrant your Toro Commercial Product ("Product") to be free from defects in materials or workmanship for two years or 1500 operational hours\*, whichever occurs first. This warranty is applicable to all products with the exception of Aerators (refer to separate warranty statements for these products). Where a warrantable condition exists, we will repair the Product at no cost to you including diagnosis, labor, parts, and transportation. This warranty begins on the date the Product is delivered to the original retail purchaser.

\* Product equipped with hour meter

#### Instructions for Obtaining Warranty Service

You are responsible for notifying the Commercial Products Distributor or Authorized Commercial Products Dealer from whom you purchased the Product as soon as you believe a warrantable condition exists. If you need help locating a Commercial Products Distributor or Authorized Dealer, or if you have questions regarding your warranty rights or responsibilities, you may contact us at:

Toro Commercial Products Service Department  
Toro Warranty Company  
8111 Lyndale Avenue South  
Bloomington, MN 55420-1196  
952-888-8801  
E-mail: commercial.warranty@toro.com

#### Owner Responsibilities

As the Product owner, you are responsible for required maintenance and adjustments stated in your *Operator's Manual*. Failure to perform required maintenance and adjustments can be grounds for disallowing a warranty claim.

#### Items and Conditions Not Covered

Not all product failures or malfunctions that occur during the warranty period are defects in materials or workmanship. This warranty does not cover the following:

- Product failures which result from the use of non-Toro replacement parts, or from installation and use of add-on, or modified non-Toro branded accessories and products. A separate warranty may be provided by the manufacturer of these items.
- Product failures which result from failure to perform recommended maintenance and/or adjustments. Failure to properly maintain your Toro product per the Recommended Maintenance listed in the *Operator's Manual* can result in claims for warranty being denied.
- Product failures which result from operating the Product in an abusive, negligent or reckless manner.
- Parts subject to consumption through use unless found to be defective. Examples of parts which are consumed, or used up, during normal Product operation include, but are not limited to, brakes pads and linings, clutch linings, blades, reels, bed knives, tines, spark plugs, castor wheels, tires, filters, belts, and certain sprayer components such as diaphragms, nozzles, and check valves, etc.
- Failures caused by outside influence. Items considered to be outside influence include, but are not limited to, weather, storage practices, contamination, use of unapproved coolants,

lubricants, additives, fertilizers, water, or chemicals, etc.

- Normal noise, vibration, wear and tear, and deterioration.
- Normal "wear and tear" includes, but is not limited to, damage to seats due to wear or abrasion, worn painted surfaces, scratched decals or windows, etc.

#### Parts

Parts scheduled for replacement as required maintenance are warranted for the period of time up to the scheduled replacement time for that part. Parts replaced under this warranty are covered for the duration of the original product warranty and become the property of Toro. Toro will make the final decision whether to repair any existing part or assembly or replace it. Toro may use remanufactured parts for warranty repairs.

#### Note Regarding Deep Cycle Battery Warranty:

Deep cycle batteries have a specified total number of kilowatt-hours they can deliver during their lifetime. Operating, recharging, and maintenance techniques can extend or reduce total battery life. As the batteries in this product are consumed, the amount of useful work between charging intervals will slowly decrease until the battery is completely worn out. Replacement of worn out batteries, due to normal consumption, is the responsibility of the product owner. Battery replacement may be required during the normal product warranty period at owner's expense.

#### Maintenance is at Owner's Expense

Engine tune-up, lubrication cleaning and polishing, replacement of filters, coolant, and completing Recommended Maintenance are some of the normal services Toro products require that are at the owner's expense.

#### General Conditions

Repair by an Authorized Toro Distributor or Dealer is your sole remedy under this warranty.

**Neither The Toro Company nor Toro Warranty Company is liable for indirect, incidental or consequential damages in connection with the use of the Toro Products covered by this warranty, including any cost or expense of providing substitute equipment or service during reasonable periods of malfunction or non-use pending completion of repairs under this warranty. Except for the Emissions warranty referenced below, if applicable, there is no other express warranty. All implied warranties of merchantability and fitness for use are limited to the duration of this express warranty.**

Some states do not allow exclusions of incidental or consequential damages, or limitations on how long an implied warranty lasts, so the above exclusions and limitations may not apply to you. This warranty gives you specific legal rights, and you may also have other rights which vary from state to state.

#### Note regarding engine warranty:

The Emissions Control System on your Product may be covered by a separate warranty meeting requirements established by the U.S. Environmental Protection Agency (EPA) and/or the California Air Resources Board (CARB). The hour limitations set forth above do not apply to the Emissions Control System Warranty. Refer to the Engine Emission Control Warranty Statement printed in your *Operator's Manual* or contained in the engine manufacturer's documentation for details.

#### Countries Other than the United States or Canada

Customers who have purchased Toro products exported from the United States or Canada should contact their Toro Distributor (Dealer) to obtain guarantee policies for your country, province, or state. If for any reason you are dissatisfied with your Distributor's service or have difficulty obtaining guarantee information, contact the Toro importer.