



Groundsmaster[®] 4500-D

Model No. 30856 - 240000001 and up.

Parts Catalog

Ordering Replacement Parts

To order replacement parts, please supply the part number, the quantity, and the description of each part desired.

Understanding Reference Numbers

Each identified part in an illustration has a reference number. The reference number for a part also appears in the parts list, along with other information about the part.

This catalog uses two special reference number formats, one to indicate parts in a service assembly and another to indicate the quantity of a given part in an illustration.

Service Assembly Reference Numbers

Parts in service assemblies have reference numbers in the form a:b. The a represents the reference number of the entire service assembly and the b represents a sequential number unique to each part within the service assembly.

For example, a wheel assembly might be identified by reference number 6, the tire by 6:1, the valve by 6:2, and the wheel by 6:3. When you order the assembly identified by reference number 6, you receive all parts identified by reference numbers 6:1, 6:2, and 6:3. However, you may also order any part individually. Reference numbers of this type appear in illustrations and in part lists.

Reference Numbers Indicating Quantity

In an illustration, if a reference number indicates more than one part, the reference number has the form nX y. The n represents the quantity of the part, the X is the multiplication symbol, and the y represents the reference number.

For example, in an illustration, the reference number 2X 37 means that two of the parts identified by reference number 37 are indicated.

Contents

Description	Page	Description	Page
Hood Screen and Bumper Assembly 4	Front Frame Assembly No. 104-5469 53
Steering Tower Assembly 6	Roller Support and Access Panel Assembly 54
Steering Valve Assembly No. 104-2213 8	Manifold Assembly 55
Traction and Brake Pedal Assembly 9	Manifold Assembly No. 104-5475 56
Throttle and Seat Frame Assembly 10	4 Wheel Drive Manifold and Filter Assembly 57
Control Console Assembly 11	Filter Manifold Assembly No. 100-5558 58
Hydraulic Filter and Reservoir Assembly 12	4 Wheel Drive Manifold Assembly No. 105-9875 59
Fuel Tank and Filter Assembly 13	Traction Hydraulic Line Assembly 60
Front Drive and Brake Assembly 14	Steering Hydraulic Line Assembly 61
Planetary Assembly No. 105-4500-03 15	Mow Block Hydraulic Line Assembly 62
Brake Assembly No. 100-3070-03 16	Lift Hydraulic Line Assembly 63
Piston Motor Assembly No. 105-1218 17	Lift Valve and Counter Balance Assembly 64
Brake Assembly No. 100-3069-03 18	Manifold Assembly No. 104-5495 65
Manifold Mounting and Fitting Assembly 19	Single Spool Valve Assembly No. 104-5494 66
Hydraulic Pump Assembly 20	Crankcase Assembly 67
Triple Pump Assembly No. 105-9845 21	Oil Pan Assembly 68
Piston Pump Assembly No. 105-9846 22	Cylinder Head Assembly 69
Control Assembly No. 93-6306 24	Gear Case Assembly 70
Radiator Assembly 25	Head Cover Assembly 71
Fan and Solenoid Assembly 26	Oil Filter Assembly 72
Engine Installation Assembly 27	Dipstick and Guide Assembly 73
Air Cleaner Assembly No. 99-5410 28	Oil Pump Assembly 74
Rear Axle Assembly 29	Breather Assembly 75
Cylinder Assembly No. 105-9861 30	Main Bearing Case 76
Piston Motor Assembly No. 105-1219 31	Camshaft and Idler Gear Shaft Assembly 77
Bevel Pinion Shaft Assembly Rear Axle Assembly No. 100-3784 32	Piston and Crankshaft Assembly 78
Differential Assembly Rear Axle Assembly No. 100-3784 33	Flywheel Assembly 79
Axle Support Assembly Rear Axle Assembly No. 100-3784 34	Fuel Camshaft and Governor Shaft Assembly 80
Bevel Gear Case Assembly Rear Axle Assembly No. 100-3784 35	Engine Stop Lever Assembly 81
Bevel Gear Shaft Assembly Rear Axle Assembly No. 100-3784 36	Injection Pump Assembly 82
Axle Case Assembly Rear Axle Assembly No. 100-3784 37	Injection Pump Component Parts Assembly 83
Axle Assembly Rear Axle Assembly No. 100-3784 38	Governor Assembly 84
Coupler Spacer and Adapter Plate Assembly 39	Speed Control Plate Assembly 85
Battery Installation Assembly 40	Nozzle Holder and Glow Plug Assembly 86
Water and Fuel Filter Assembly No. 98-9305 41	Fuel Filter and Fuel Pump 87
Front Lift Arm Assembly 42	Alternator and Pulley Assembly 88
Lift Cylinder Assembly No. 104-5527 44	Alternator Component Parts Assembly 89
Lift Cylinder Assembly No. 104-5528 45	Starter Assembly 90
Lift Lever Assembly 46	Starter Component Parts Assembly 91
No. 2 and 3 Lift Arm Assembly 47	Oil Switch / Thermometer and Plug Assembly 92
Lift Cylinder Assembly No. 104-5526 48	Water Flange and Thermostat Assembly 93
Hose Installation Assembly 49	Water Pump Assembly 94
No. 1, 4 and 5 Hose Installation Assembly 50	Water Pipe Assembly 95
Hydraulic Motor Assembly No. 105-9820 51	Fan Assembly 96
Roll-Over Protection System and Frame Assembly 52	Valve and Rocker Arm Assembly 97
		Inlet Manifold Assembly 98
		Exhaust Manifold Assembly 99
		Turbo Charger Assembly 100
		Oil Pipe (Turbo Charger) Assembly 101
		Oil Cooler Assembly 102
		Muffler Gasket and Glow Controller 103
		Engine Operator Manual 104
		Gasket Kit 105

Part Description Abbreviations

Part descriptions in this catalog may include the following abbreviations.

AR.	as required	HYD.	hydraulic
ASM.	assembly	LH.	left hand
BBC.	blade brake clutch	NI.	nylon insert
CARR.	carriage	NPTF.	national pipe thread fine
DEG.	degrees	PFH.	phillips flat head
EXT.	external	PPH.	phillips pan head
FH.	flat head	PPHTF.	phillips pan head thread forming
GA.	gauge	PRH.	phillips round head
HD.	heavy-duty	PTH.	phillips truss head
HF.	hex flange	PTO.	power-take-off
HH.	hex head	RH.	right hand
HHF.	hex head flange	ROPS.	roll-over protection system
HHFTF.	hex head flange thread forming	SFH.	slotted fillister head
HJ.	hex jam	SHH.	slotted hex head
HLH.	hex lag head	SHWH.	slotted hex washer head
HOC.	height-of-cut	SPH.	slotted pan head
HSBH.	hex socket button head	SQH.	square head
HSFH.	hex socket flat head	SRH.	slotted round head
HSH.	hex socket head	STD.	standard
HWH.	hex washer head	TAP.	self tapping
HWHTF.	hex washer head thread forming	TTH.	torx truss head

Footnotes

❶ Not illustrated

❷ Not serviced separately

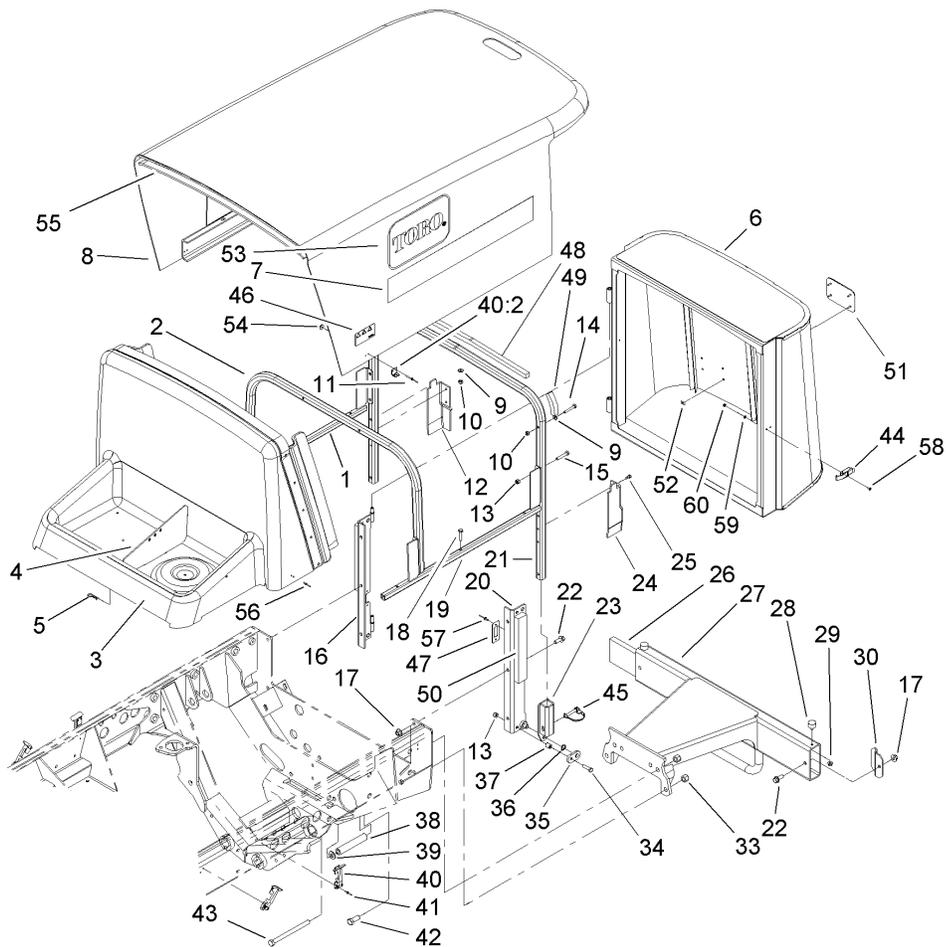

Hood Screen and Bumper Assembly

Ref	Part No.	Qty.	Description
1	107-1975-03	1	RH Hood Frame ASM
2	107-1973-03	1	Tube-Front, Hood
3	104-5430	1	Shroud-Front
4	104-5446-03	1	Divider-Shroud
5	3290-467	2	Pin-Hair
6	104-5454-03	1	Screen ASM
7	105-9877	2	Decal
8	104-5419	1	Hood
8:1	106-8116	1	Heat Tape Repair Kit
9	3256-22	12	Washer-Flat
10	3296-42	12	Nut-Lock, NI
11	3269-17	4	Rivet-Pop
12	104-5431	1	Cover-Tube, RH
13	3296-29	10	Nut-Lock, NI
14	321-10	6	Screw-HH
15	322-9	8	Screw-HH
16	104-5445-03	1	RH Support ASM
17	32128-43	6	Nut-Flange
18	321-13	6	Screw-HH
19	107-1974-03	1	LH Hood Frame ASM
20	104-5444-03	1	LH Support ASM
21	104-5435-03	1	Tube-Rear, Hood
22	3234-11	6	Screw-HHF
23	104-5440-03	2	Hood Receiver ASM

Ref	Part No.	Qty.	Description
24	104-5432	1	Cover-Tube, LH
25	32104-17	4	Screw-HWH
26	105-9199-03	1	Weight-Bumper
27	105-9221-03	1	Rear Bumper ASM
28	240-14	2	Bumper-Rubber
29	32128-33	2	Nut-HF
30	105-9200-03	2	Clamp-Weight, Bumper
33	3296-23	4	Nut-Lock, NI
34	322-17	2	Screw-HH
35	104-5450	2	Retainer-Receiver, Hood
36	3290-221	2	Washer-Spring
37	104-5451	2	Spacer-Receiver, Hood
38	76-8350	2	Stop-Axle
39	3256-26	2	Washer-Flat
40	59-9740	4	Flex Draw Latch ASM
40:2	249-40	1	Keeper
41	3290-55	8	Rivet-Pop
42	325-6	2	Screw-HH
43	325-33	2	Screw-HH
44	105-3912	1	Latch-Draw
45	105-9245	2	Pin-Lock
46	106-6754	2	Decal-Danger
47	104-5459	1	Plate-Latch
48	105-9234	1	Seal-Foam

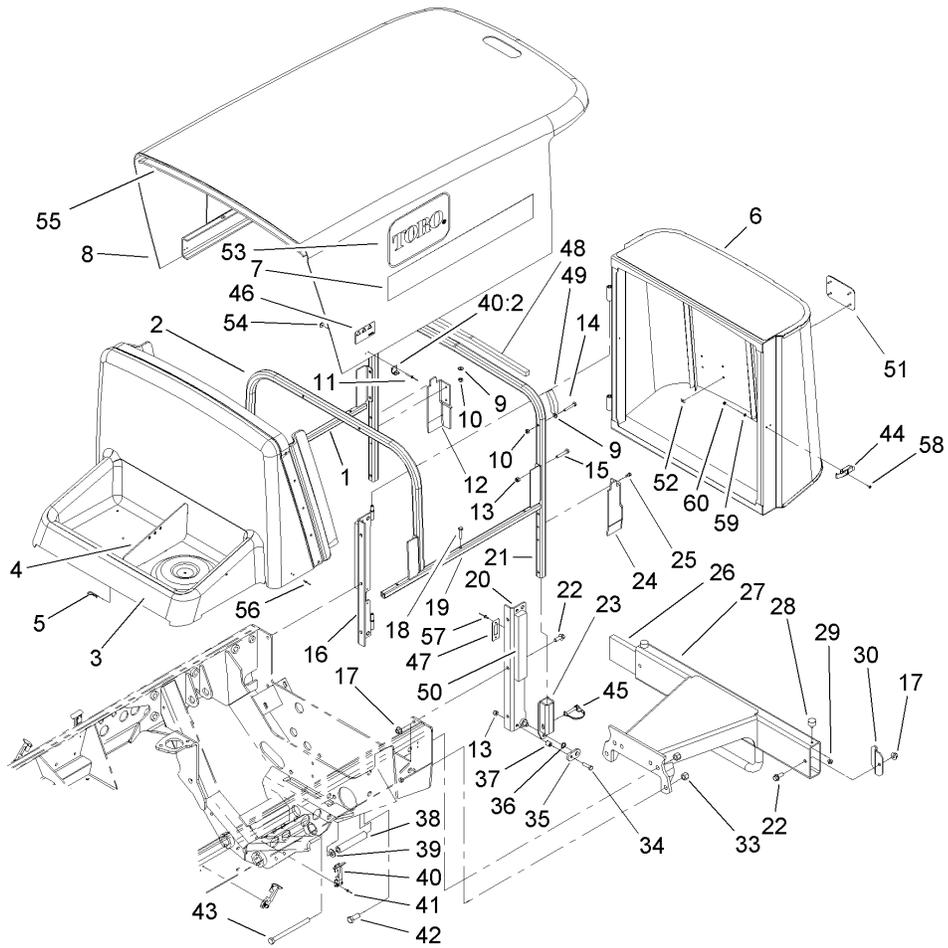

Hood Screen and Bumper Assembly (continued)

Ref	Part No.	Qty.	Description
49	105-9237	2	Seal-Foam
50	105-9235	2	Seal-Foam
51	93-6028	1	Plate-Logo
52	94-2638	4	Nut-Tinnerman
53	66-1210	2	Decal
54	3269-10	8	Washer-Back
55	105-9829	1	Seal-Foam
56	3290-55	4	Rivet-Pop
57	3269-15	2	Rivet
58	3249-3	2	Screw
59	3256-53	2	Washer-Flat
60	3296-9	2	Nut-Lock

--	--	--	--

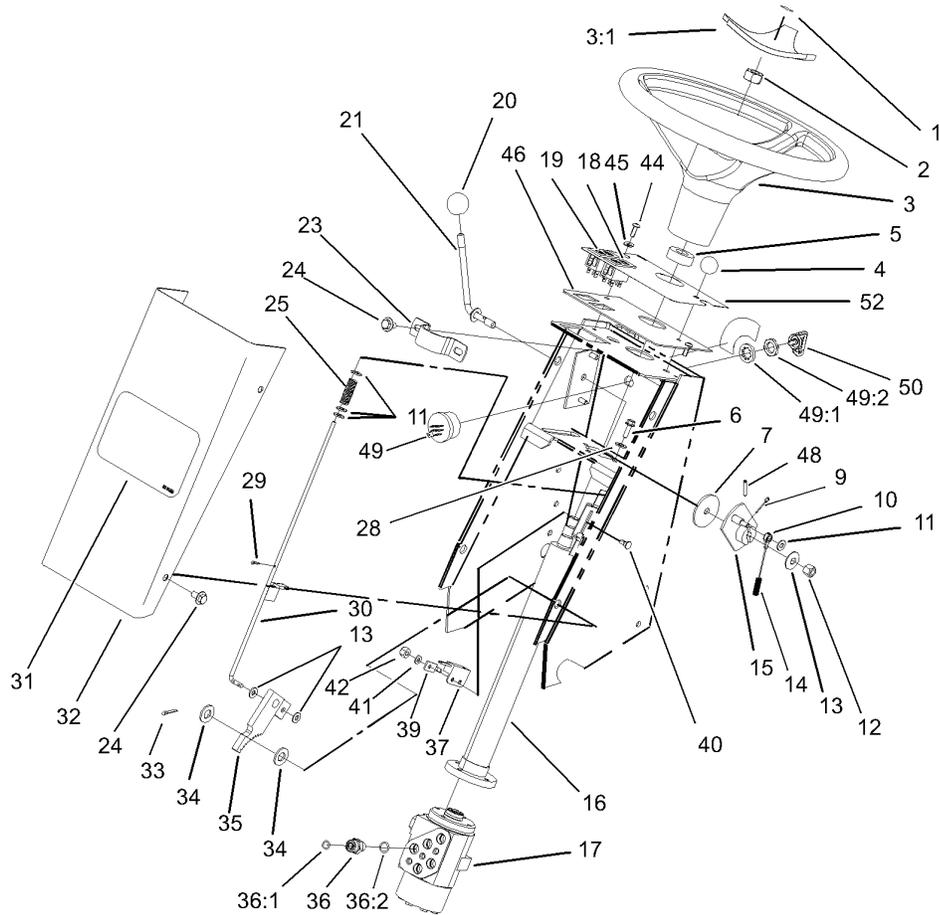

Steering Tower Assembly

Ref	Part No.	Qty.	Description
1	98-1459	1	Decal
2	94-9952	1	Nut-Hex
3	98-1471	1	Wheel-Steering
3:1	98-1468	1	Cover-Wheel, Steering
4	233-17	1	Knob
5	21-9260	1	Cover-Dust
6	33103-016	3	Screw-HHF
7	75-6550	1	Disc-Friction
9	3272-2	1	Pin-Cotter
10	75-6580	1	Cable-Pedal
11	3256-22	5	Washer-Flat
12	3296-39	1	Nut-Lock, NI
13	3290-461	1	Washer-Spring
14	95-7151	1	Tube-Convolute
15	75-6510	1	Bracket-Lever
16	94-9951	1	Column-Steering
17	104-2213	1	Valve-Steering
18	100-8071	1	Lamp-Warning
19	100-8070	1	Lamp-Warning
20	233-42	1	Knob
21	75-6490	1	Lever ASM
23	75-2810	1	Bracket-Column, Steering
24	3234-7	6	Screw-HHF
25	95-1821-03	1	Spring-Compression

Ref	Part No.	Qty.	Description
28	3256-23	6	Washer-Flat
29	3272-5	3	Pin-Cotter
30	104-1492	1	Rod ASM
31	62-5550	1	Decal
32	93-7996-01	1	Cover-Tower
33	3272-10	1	Pin-Cotter
34	3256-26	2	Washer-Flat
35	63-7900-03	1	Rack ASM
36	340-2	5	Fitting-HYD, Straight
36:1	237-22	1	O-Ring
36:2	237-42	1	O-Ring
37	100-1270	1	Switch-Proximity
39	100-4872	1	Plate-Switch, Neutral
40	104-1450	1	Bolt-CARR
41	3256-14	1	Washer-Flat
42	3296-2	1	Nut-Lock
44	87-6620	2	Screw
45	3256-1	2	Washer-Flat
46	105-9232-03	1	Plate-Instrument
48	32121-45	1	Pin-Spring
49	104-2541	1	Switch ASM
49:1	218-461	1	Nut-HH
49:2	3254-5	1	Washer-Tooth
50	63-8360	1	Key-Ignition

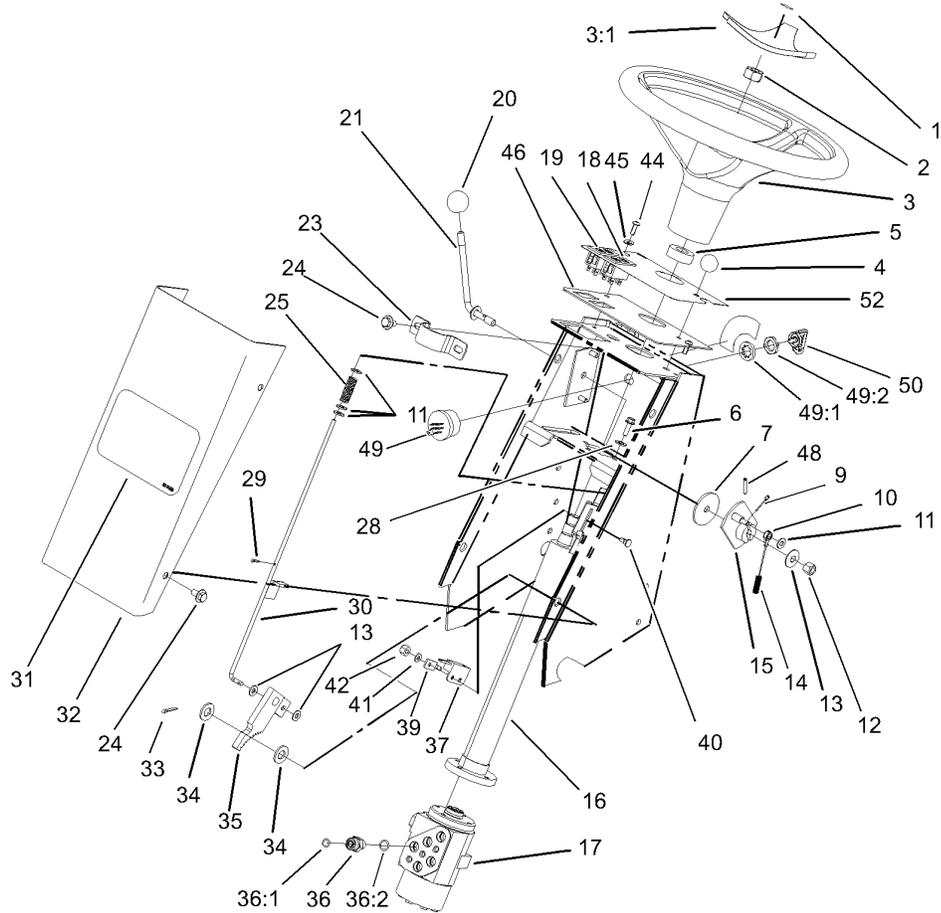

Steering Tower Assembly (continued)

Ref	Part No.	Qty.	Description
52	105-3888	1	Decal-Tower
●99	3290-379	1	Tie-Cable

--	--	--	--

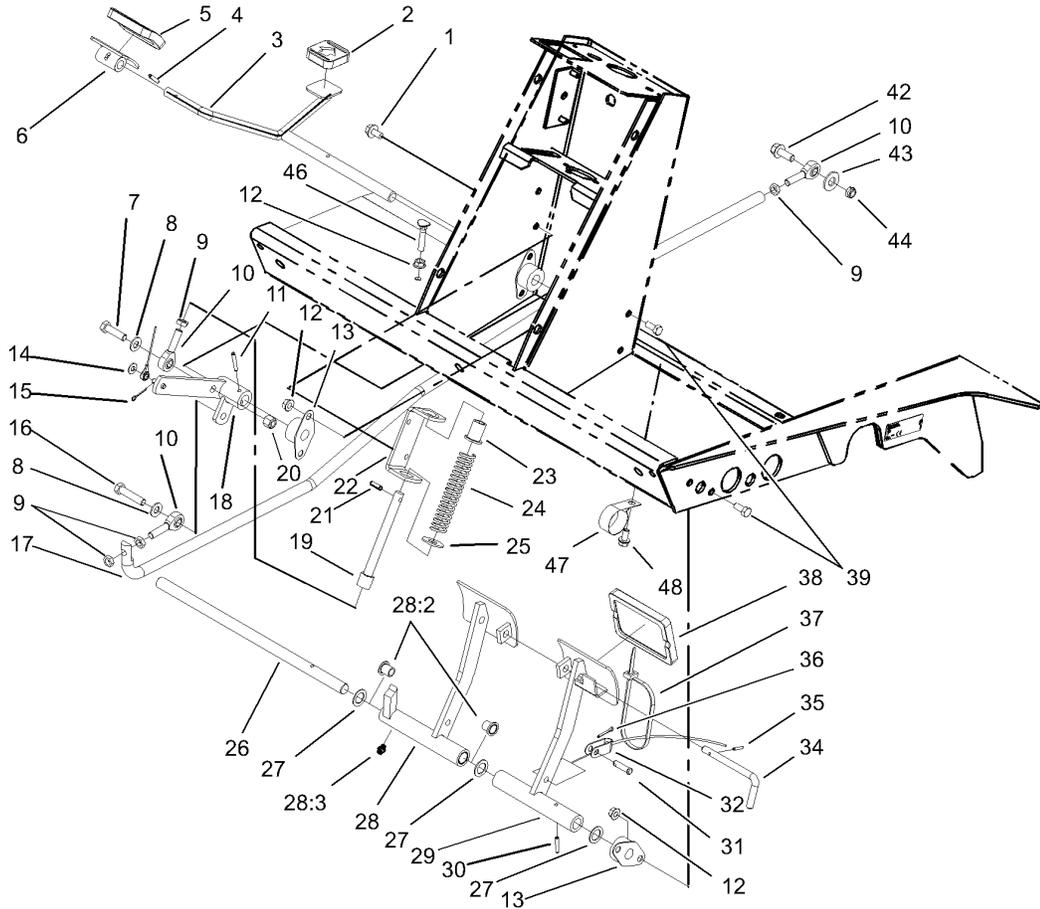

Traction and Brake Pedal Assembly

Ref	Part No.	Qty.	Description
1	32144-14	4	Screw-HWHTF
2	74-9110	1	Pad-Pedal, Reverse
3	75-2970	1	Pedal-Traction
4	32121-45	1	Pin-Spring
5	74-9100	1	Pad-Pedal, Forward
6	49-6440-03	1	Pedal-Forward
7	323-29	1	Screw-HH
8	3256-24	2	Washer-Flat
9	3220-3	4	Nut-HJ
10	2411-36	3	Bearing-End, Rod
11	32121-6	1	Pin-Roll, Slotted
12	32128-20	12	Nut-HF
13	256-236	4	Bearing-Mount, Flange
14	3256-22	1	Washer-Flat
15	3272-2	1	Pin-Cotter
16	323-9	1	Screw-HH
17	104-5632-03	1	Rod-Control, Pump
18	75-3270-03	1	Hub-Pivot, Traction
19	92-7609	1	Shaft-Spring
20	3296-39	2	Nut-Lock, NI
21	32121-11	1	Pin-Roll
22	92-7608-03	1	Bracket-Spring
23	92-7610	1	Retainer-Spring
24	84-9100	1	Spring

Ref	Part No.	Qty.	Description
25	3256-5	1	Washer-Flat
26	75-1470	1	Pin-Pivot, Brake
27	3256-69	3	Washer-Flat
28	75-1430	1	Pedal-Brake, RH
28:2	256-42	2	Bushing
28:3	302-5	1	Fitting-Grease
29	75-1440-03	1	LH Brake Pedal ASM
30	32121-16	1	Pin-Spring
31	283-58	2	Pin-Clevis
32	92-7530	1	LH Brake Cable ASM
33	92-7529	1	RH Brake Cable ASM
34	63-7880	1	Pin-Latch, Brake
35	32121-50	1	Pin-Spring
36	3272-10	2	Pin-Cotter
37	3290-378	1	Tie-Cable
38	93-8742	2	Footpad-Brake
39	322-3	8	Screw-HH
42	3234-11	1	Screw-HHF
43	5-0652	1	Spacer
44	3296-59	1	Nut-Lock, NI
46	17-9420	2	Screw-Handle
47	2412-150	1	Clip-J
48	3234-14	1	Screw-HHF

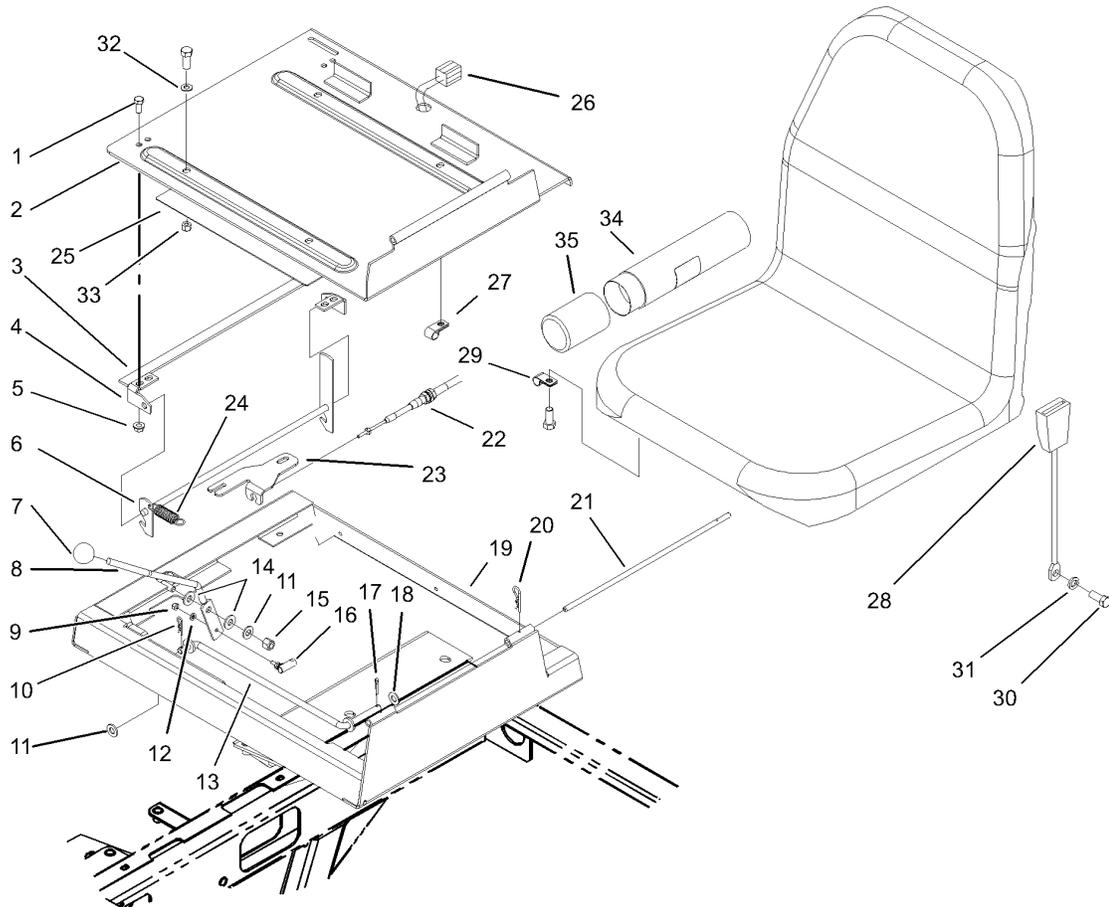

Throttle and Seat Frame Assembly

Ref	Part No.	Qty.	Description
1	322-3	8	Screw-HH
2	98-2350-03	1	Seat Plate ASM
3	94-8146	1	Strip-Foam
4	98-2353	2	Bracket-Latch, Seat
5	32128-25	4	Nut-HF
6	98-2354-03	1	Latch-Seat
7	233-42	1	Knob
8	93-7598-03	1	Lever-Throttle
9	3296-21	1	Nut-Lock, NI
10	3290-307	1	Pin-Hair
11	3256-24	3	Washer-Flat
12	3256-51	1	Washer-Flat
13	75-3680-03	1	Rod-Seat
14	66-2920	2	Washer-Friction
15	3296-39	1	Nut-Lock, NI
16	2411-38	1	Joint-Ball
17	3272-10	1	Pin-Cotter
18	52-2900	2	Washer-Plastic
19	98-2352-03	1	Frame-Seat
20	3290-467	1	Pin-Hair
21	75-3400	1	Shaft-Pivot, Seat
22	104-7547	1	Cable-Throttle
23	105-3929-03	1	Bracket-Cable, Throttle
24	66-4190-03	1	Spring-Idler, Clutch

Ref	Part No.	Qty.	Description
25	105-9895	1	Decal-Quick Reference
26	105-9189	1	Harness-Wire, Seat Switch
27	2412-133	2	R-Clamp
28	100-4928	1	Belt-Seat
29	2412-93	1	Clamp-R
30	3212-4	2	Screw-HH
31	3253-6	2	Washer-Lock
32	3256-23	4	Washer-Flat
33	3296-29	10	Nut-Lock, NI
34	104-7050	1	Housing-Manual
35	104-7048	1	Cap-Housing

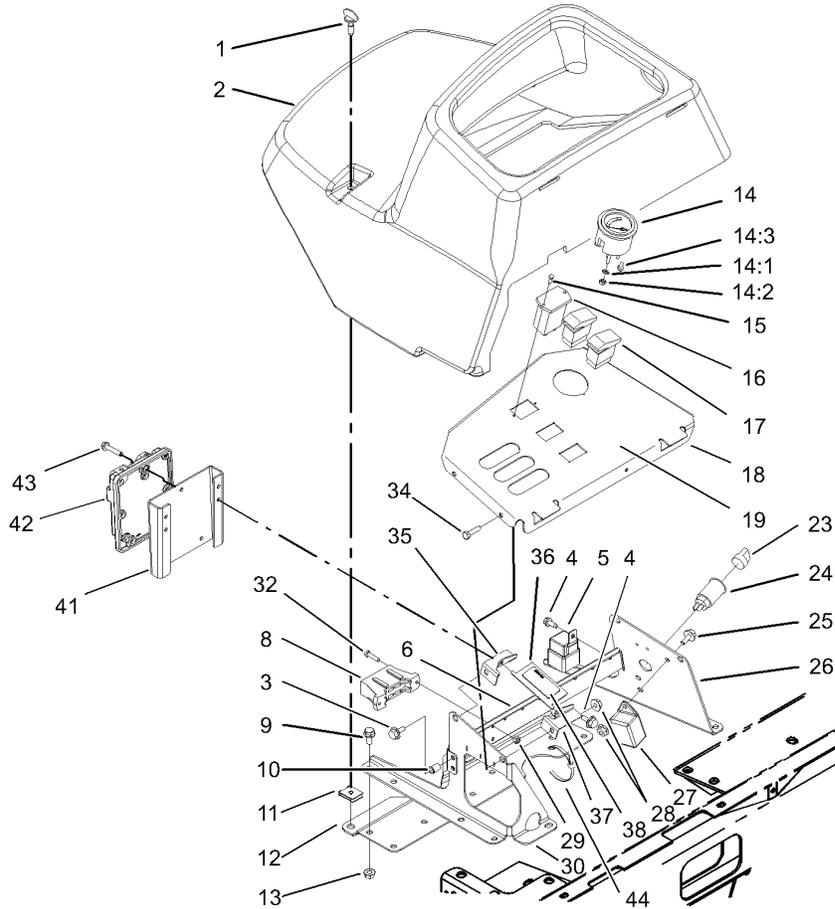

Control Console Assembly

Ref	Part No.	Qty.	Description
1	105-9208	2	Screw-Head, Wing
2	104-5599	1	Cover-Console
3	3234-13	4	Screw-HHF
4	32144-10	7	Screw-HWH
5	99-7430	3	Relay
6	104-5613-03	1	Panel-Relay
8	105-9867	1	Harness-Wire, Console
9	3234-14	9	Screw-HHF
10	32148-6	6	Insert-Nut
11	105-9209	2	Recepticle-Clip On
12	104-5612-03	1	Support-Cover
13	32128-20	4	Nut-HF
14	98-9308	1	Gauge-Temperature
14:1	3254-1	3	Washer-Lock, Int
14:2	3217-27	3	Nut-Hex
14:3	105-9265	1	Bulb And Lamp ASM
15	32144-18	2	Screw-HH
16	75-6820	1	Hourmeter
17	95-8999	2	Switch
18	104-5611-03	1	Dash
19	105-3890	1	Decal-Console
●19	105-9223	1	Decal-Console, Ce
23	99-7416	1	Cap
24	99-7411	1	Point-Power

Ref	Part No.	Qty.	Description
25	3234-4	1	Screw-HHF
26	104-5610-03	1	Panel-Dash, Rear
27	98-7611	1	Controller-Glow
28	32128-33	3	Nut-HF
29	3296-2	6	Nut-Lock
30	104-5609-03	1	Panel-Dash, Front
●31	105-3986	1	Module-Control, Deck
32	32105-13	6	Screw-HWH
34	321-6	2	Screw-HH
35	105-9840	1	Bracket-Latch, RH
36	105-9842	1	Plate-Latch, Ce
37	105-9841	1	Bracket-Latch, LH
38	105-9830	1	Decal-Lever Lock, Ce
41	105-9873-03	1	Bracket-Module
42	105-8505	1	Module-Control, Standard
43	32144-110	3	Screw-HWH
44	3290-379	5	Tie-Cable

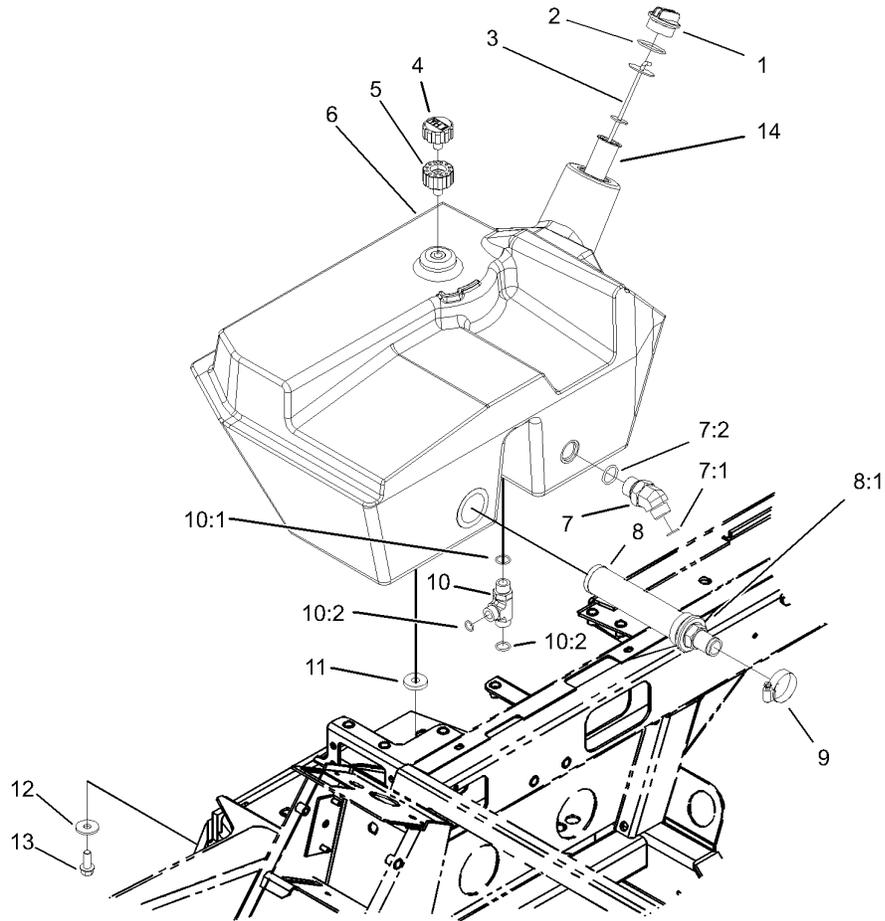

Hydraulic Filter and Reservoir Assembly

Ref	Part No.	Qty.	Description
1	93-7498	1	Plug-Plastic
2	94-8166	1	O-Ring
3	75-3710	1	Dipstick
4	68-6150	1	Breather
5	92-8020	1	Adapter-Breather
6	104-5600	1	Tank-HYD
7	340-156	1	Fitting-HYD
7:1	237-65	1	O-Ring
7:2	237-81	1	O-Ring
8	104-7546	1	Strainer-Tank
8:1	340-136	1	O-Ring
9	2412-111	2	Clamp
10	340-109	1	Fitting-HYD, Tee
10:1	237-79	1	O-Ring
10:2	237-30	2	O-Ring
11	240-11	3	Bushing-Flange
12	63-8410	3	Washer
13	3234-11	3	Screw-HHF
14	61-2790	1	Filter-Screen

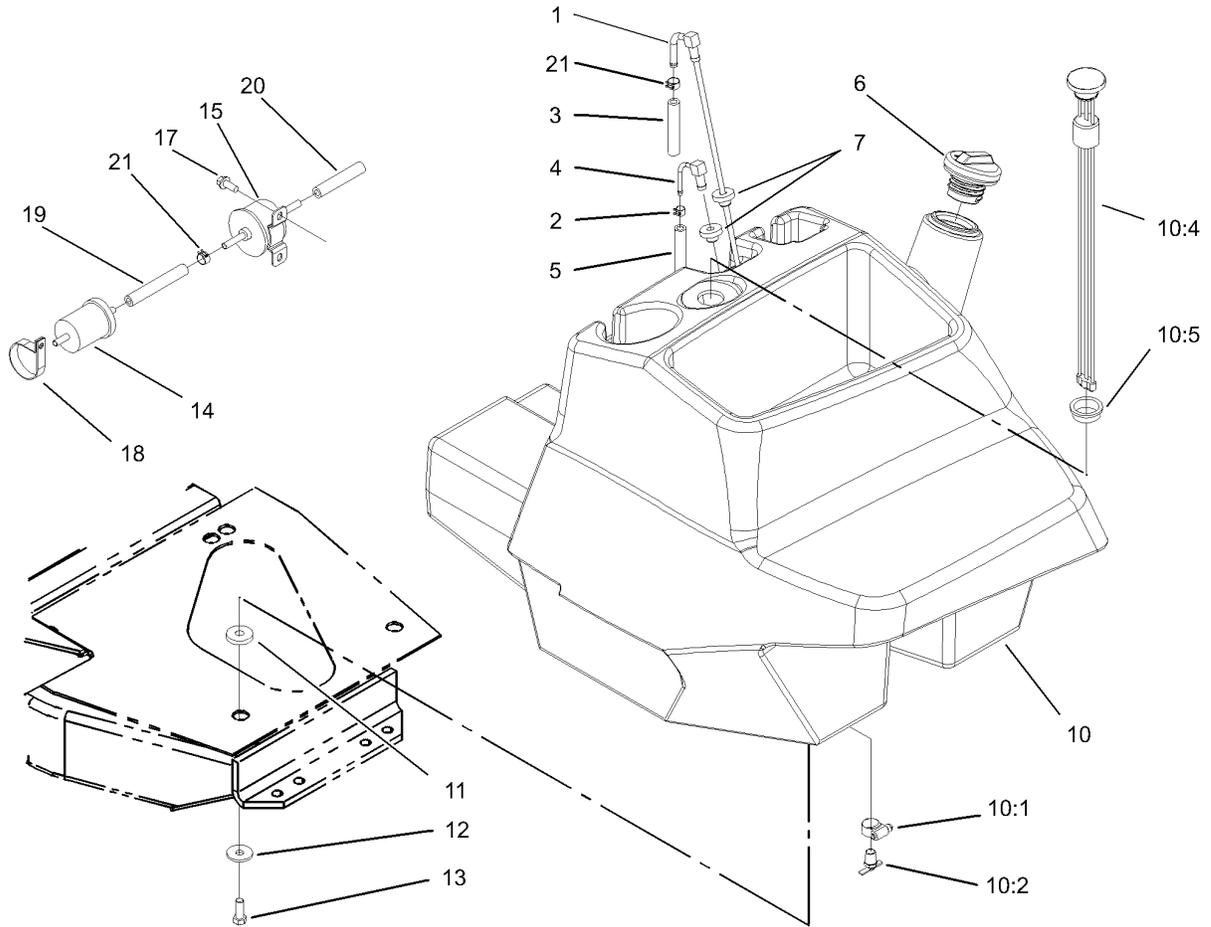

Fuel Tank and Filter Assembly

Ref	Part No.	Qty.	Description
1	104-5604	1	Fitting-Suction
2	2412-80	2	Clamp-Line, Fuel
3	39-1120	1	Hose-Fuel
4	104-5605	1	Fitting-Return
5	105-9242	1	Hose-Fuel
6	93-3102	1	Cap-Fuel
7	46-6560	2	Bushing
10	104-5601	1	Fuel Tank ASM
10:1	2412-36	1	Clamp-Hose
10:2	304-46	1	Draincock
10:4	104-5603	1	Gauge-Level, Fuel
10:5	95-8972	1	Grommet
11	240-11	4	Bushing-Flange
12	63-8410	4	Washer
13	3234-11	4	Screw-HHF
14	98-7612	1	Filter-Fuel
15	107-0122	1	Pump-Fuel, Electric
17	32144-10	3	Screw-HWH
18	2412-148	1	Clamp-R
19	105-9196	1	Hose-Fuel
20	93-2230	1	Hose-Fuel
21	92-2379	5	Clamp-Hose

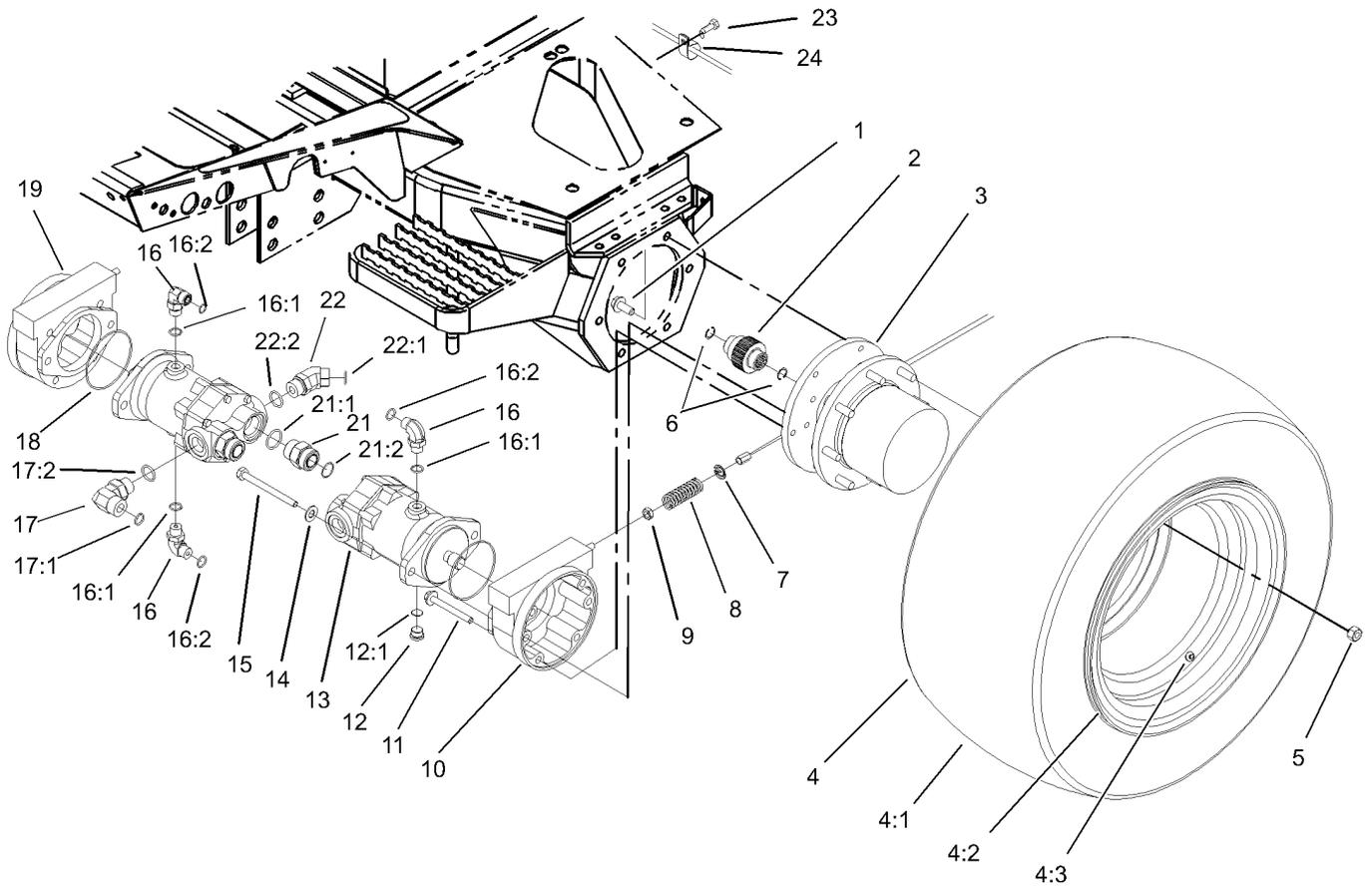

Front Drive and Brake Assembly

Ref	Part No.	Qty.	Description
1	33106-030	12	Screw-HHF
2	100-3046	2	Shaft-Brake, Splined
3	105-4500-03	2	Planetary ASM
4		2	Wheel And Tire ASM
4:1	95-3465	1	Tire
4:2	95-3464	1	Rim
4:3	232-24	1	Stem-Valve
5	92-7483	16	Nut-Lug
6	93-7972	4	Ring-Retaining, Internal
7	94-3050	2	Plate-Spring
8	94-3088	2	Spring-Compression
9	3218-4	2	Nut-Jam
10	100-3070	1	Brake ASM
11	33106-090	8	Screw-HHF
12	353-988	1	Plug-Hex
12:1	237-79	1	O-Ring
13	105-1218	2	Motor-Piston
14	3256-26	4	Washer-Flat
15	33116-120	4	Screw-HH
16	340-98	3	Fitting-HYD, 90 DEG
16:1	237-79	1	O-Ring
16:2	237-30	1	O-Ring
17	340-142	2	Fitting-HYD, 90 DEG
17:1	237-58	1	O-Ring

Ref	Part No.	Qty.	Description
17:2	237-81	1	O-Ring
18	237-166	2	O-Ring
19	100-3069	1	Brake ASM
21	104-3797	4	Fitting-HYD, Straight
21:1	237-146	1	O-Ring
21:2	340-65	1	O-Ring
22	100-5530	2	Fitting-HYD, 45 DEG
22:1	237-58	1	O-Ring
22:2	237-81	1	O-Ring
23	32144-14	2	Screw-HWHTF
24	2412-93	2	Clamp-R

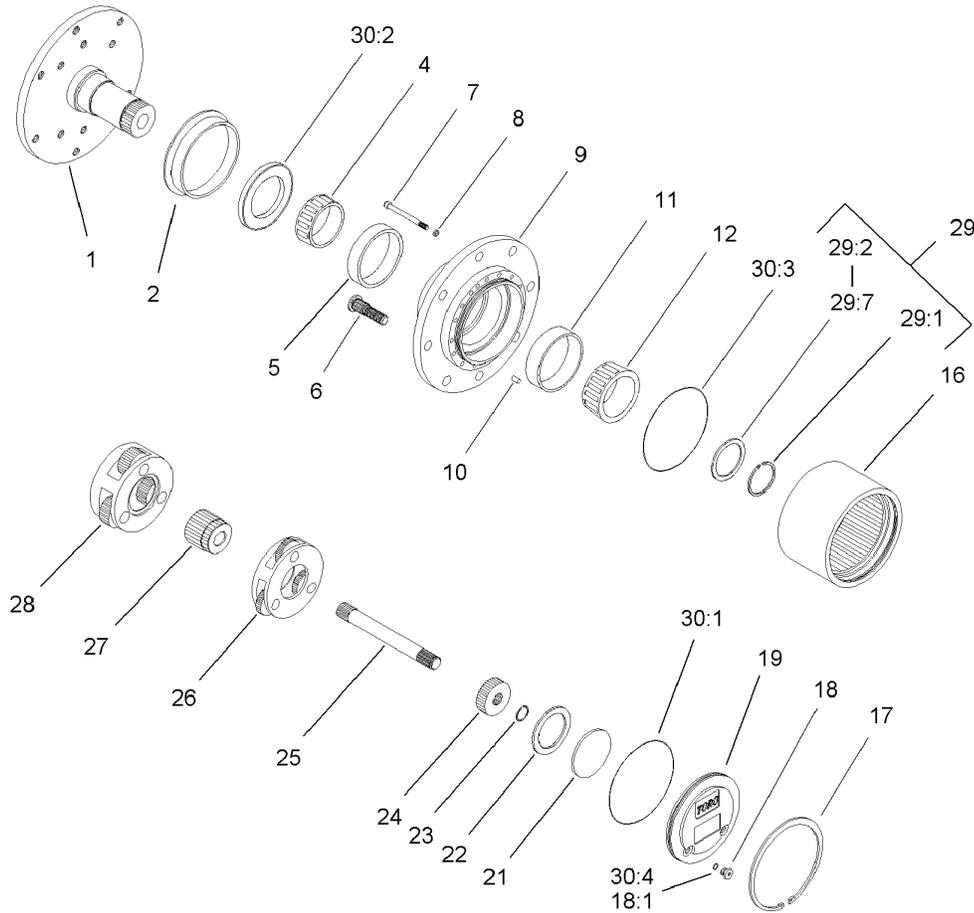

Planetary Assembly No. 105-4500-03

Ref	Part No.	Qty.	Description
②1		1	Spindle
2	105-8122	1	Seal-Boot
4	105-8120	1	Bearing-Cone
5	105-8119	1	Bearing-Cup
6	105-8124	8	Stud-Wheel
7	105-8125	16	Bolt-Head, Socket
8	3253-18	16	Washer-Lock
②9		1	Housing
10	105-8121	1	Pin-Dowel
11	105-8117	1	Bearing-Cup
12	105-8118	1	Bearing-Cone
16	105-8113	1	Gear-Ring
17	105-8132	1	Ring-Retaining
18	353-990	2	Plug
18:1	237-78	1	O-Ring
19	105-8138	1	Cap-End
21	105-8133	1	Plug-Thrust
22	105-8123	1	Washer-Thrust
23	105-8131	1	Ring-Retaining
24	105-8114	1	Gear-Primary
25	105-8115	1	Shaft-Drive
26	105-8129	1	Primary Carrier ASM
27	105-8139	1	Gear-Secondary
28	105-8130	1	Secondary Carrier ASM

Ref	Part No.	Qty.	Description
29	105-8136	1	Shim Kit
②29:1		1	Ring-Snap
②29:2		1	Shim-Bearing, 2.9Mm
②29:3		1	Shim-Bearing, 2.8Mm
②29:4		1	Shim-Bearing, 2.7Mm
②29:5		1	Shim-Bearing, 2.6Mm
②29:6		1	Shim-Bearing, 2.5Mm
②29:7		1	Shim-Bearing, 2.4Mm
①30	105-8137	1	Seal Kit
②30:1		1	O Ring-Flange Cap
②30:2		1	Seal-Oil
②30:3		2	O Ring-End Cap
30:4	237-78	2	O-Ring

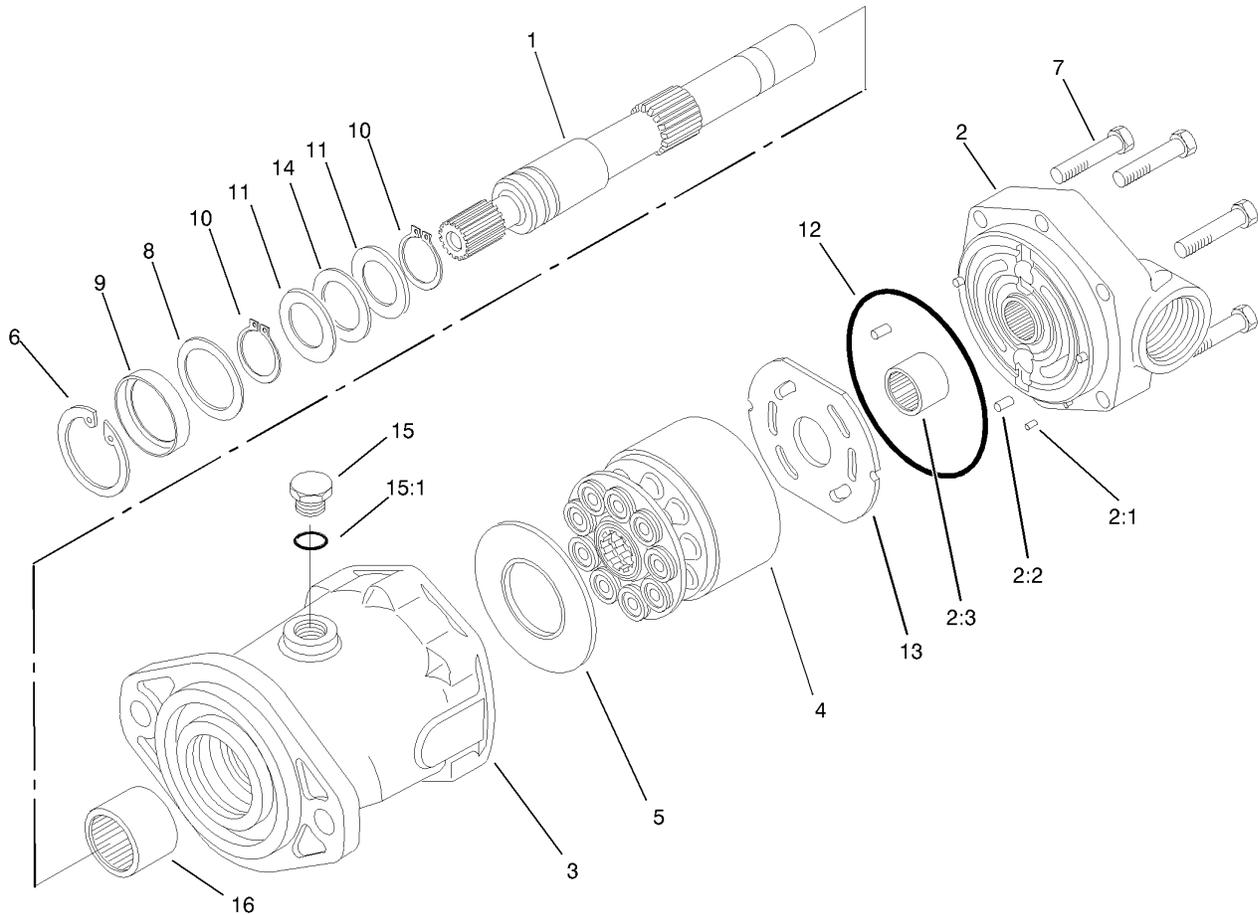

Piston Motor Assembly No. 105-1218

Ref	Part No.	Qty.	Description
1	94-3004	1	Shaft-Drive, Splined
2	105-2851	1	Backplate ASM
2:1		3	Pin-Dowel
2:2		1	Pin-Dowel
2:3		1	Bearing-Needle
2:3		1	Housing
4	76-6910	1	Rotating Kit
5	76-6970	1	Insert-Plate, Cam
6	60-6260	1	Ring
7	94-3002	6	Capscrew
8	60-6240	1	Washer
9	105-3331	1	Seal-Shaft
10	76-7000	2	Ring-Retaining
11	76-6950	2	Race-Thrust
12	76-6980	1	O-Ring
13	94-3003	1	Plate-Valve
14	60-6170	1	Bearing-Thrust
15	353-550	1	Plug-HYD, HH
15:1	237-79	1	O-Ring
16	63-4390	1	Bearing-Needle

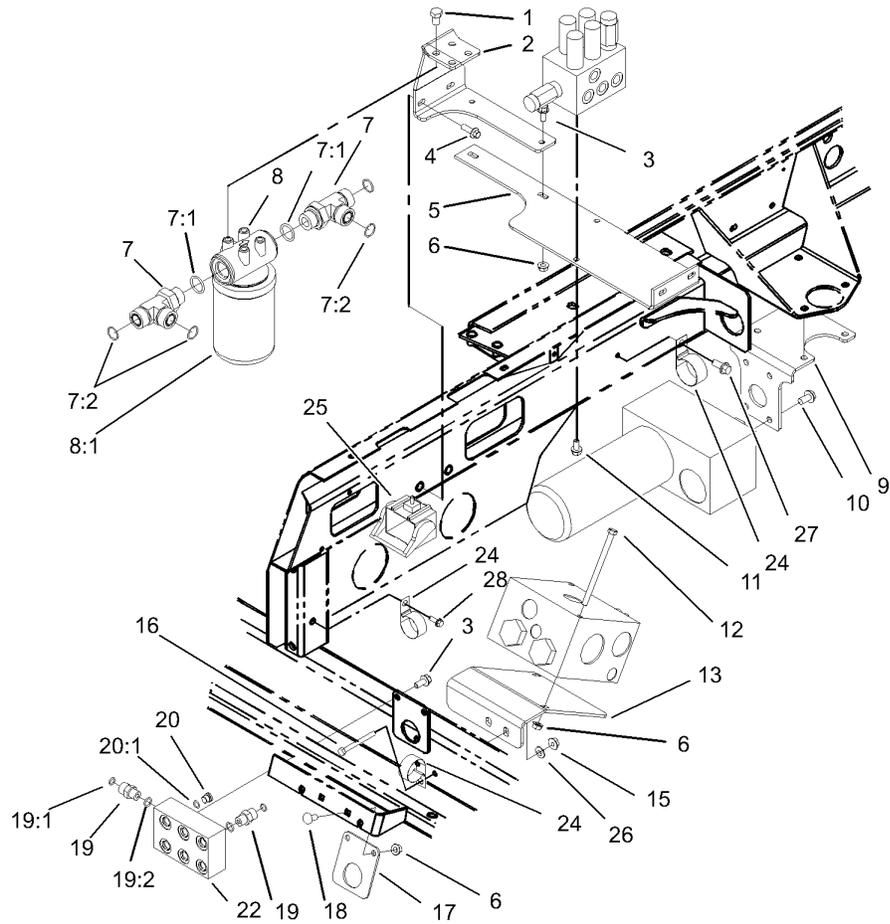

Manifold Mounting and Fitting Assembly

Ref	Part No.	Qty.	Description
1	33115-016	4	Screw-HH
2	104-5492-03	1	Bracket-Mount, Filter
3	3234-5	4	Screw-HHF
4	3234-17	4	Screw-HHF
5	104-5493-03	1	Bracket-Mount, Valve
6	32128-20	6	Nut-HF
7	340-148	2	Fitting-Tee
7:1	237-81	1	O-Ring
7:2	237-58	2	O-Ring
8	93-2242	1	Oil Filter ASM
8:1	75-1310	1	Element-Filter
9	104-5471-03	1	Bracket-Valve, Filter
10	3234-1	4	Screw-HHF
11	3234-14	2	Screw-HHF
12	322-48	2	Screw-HH
13	104-5467-03	1	Bracket-Mount, Valve
15	32128-33	2	Nut-HF
16	321-14	2	Screw-HH
17	104-5516-01	1	Support-Tube
18	3230-23	2	Screw-CARR
19	340-2	4	Fitting-HYD, Straight
19:1	237-22	1	O-Ring
19:2	237-42	1	O-Ring
20	353-990	1	Plug

Ref	Part No.	Qty.	Description
20:1	237-78	1	O-Ring
22	104-5515	1	Manifold-Junction, Lift
24	2412-150	3	Clip-J
25	105-9868	1	Harness-Wire, Main
26	3256-22	2	Washer-Flat
27	32144-14	1	Screw-HWHTF
28	3234-4	1	Screw-HHF

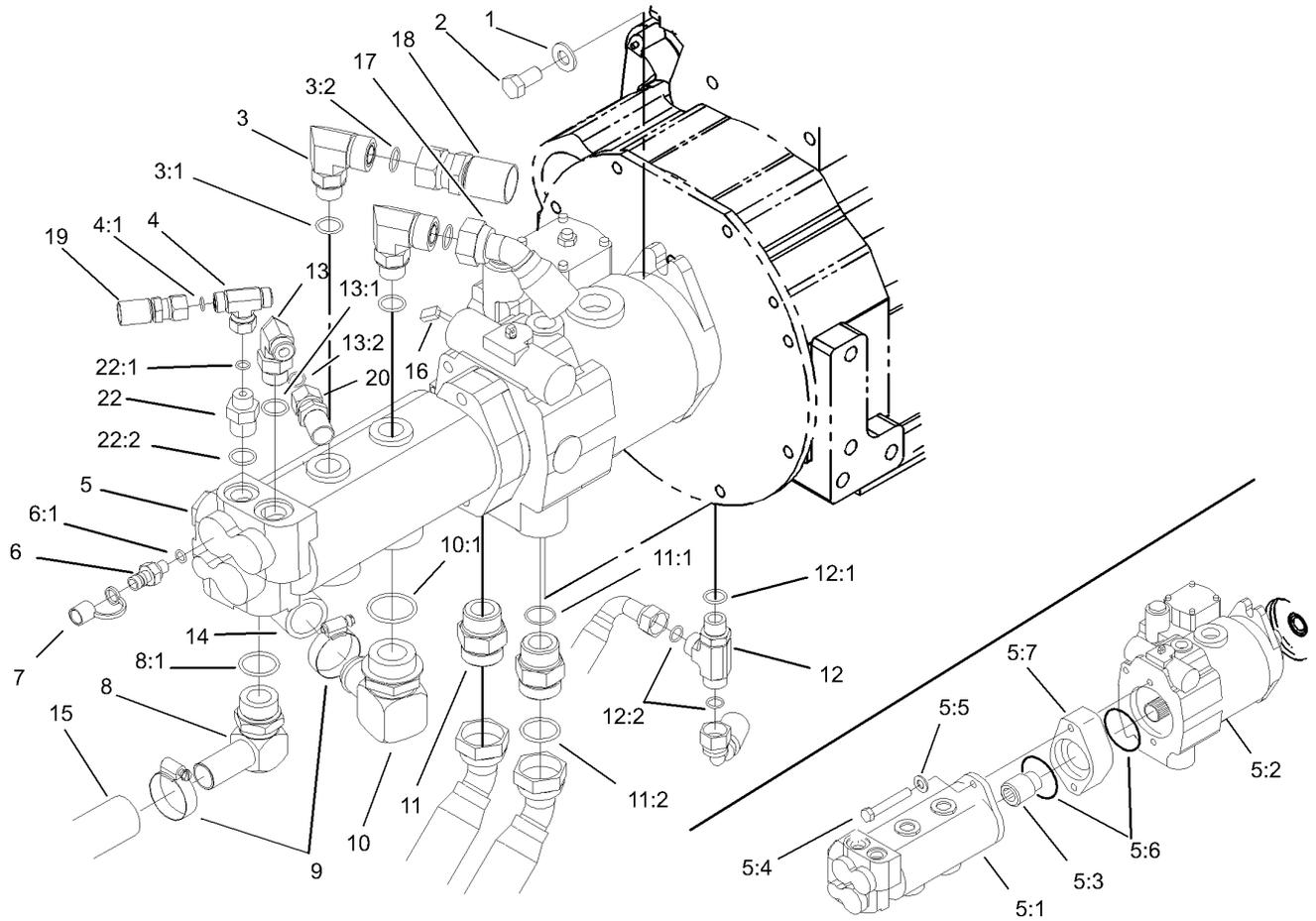

Hydraulic Pump Assembly

Ref	Part No.	Qty.	Description
1	87-7270	2	Washer-Thrust
2	3213-2	2	Screw-HH
3	340-16	2	Fitting-HYD, 90 DEG
3:1	237-80	1	O-Ring
3:2	237-58	1	O-Ring
4	340-166	1	Fitting-Tee, HYD
4:1	237-22	1	O-Ring
5		1	Pump ASM
5:1	105-9845	1	Triple Pump ASM
5:2	105-9846	1	Piston Pump ASM
5:3	74-9030	1	Coupler
5:4	323-32	2	Screw-HH
5:5	60-3540	2	Washer
5:6	60-3520	2	O-Ring
5:7	99-5510	1	Spacer
6	354-77	2	Fitting-Quick
6:1	237-78	1	O-Ring
7	354-79	2	Cap-Dust
8	56-9530	1	Fitting-HYD, 90 DEG
8:1	237-117	1	O-Ring
9	2412-111	2	Clamp
10	92-7526	1	Fitting-HYD, 90 DEG
10:1	237-101	1	O-Ring
11	104-3797	2	Fitting-HYD, Straight

Ref	Part No.	Qty.	Description
11:1	237-146	1	O-Ring
11:2	340-65	1	O-Ring
12	340-109	1	Fitting-HYD, Tee
12:1	237-79	1	O-Ring
12:2	237-30	2	O-Ring
13	340-98	1	Fitting-HYD, 90 DEG
13:1	237-79	1	O-Ring
13:2	237-30	1	O-Ring
14	104-5482	1	Hose-Suction
15	104-5484	1	Hose-Suction
16	105-0122	1	Harness-Wire
17	105-3874	1	Hose ASM
18	105-3875	1	HYD Hose ASM
19	92-7595	1	Hose ASM
20	105-3869	1	Hose ASM
22	340-141	1	Fitting-HYD, Straight
22:1	237-22	1	O-Ring
22:2	237-80	1	O-Ring

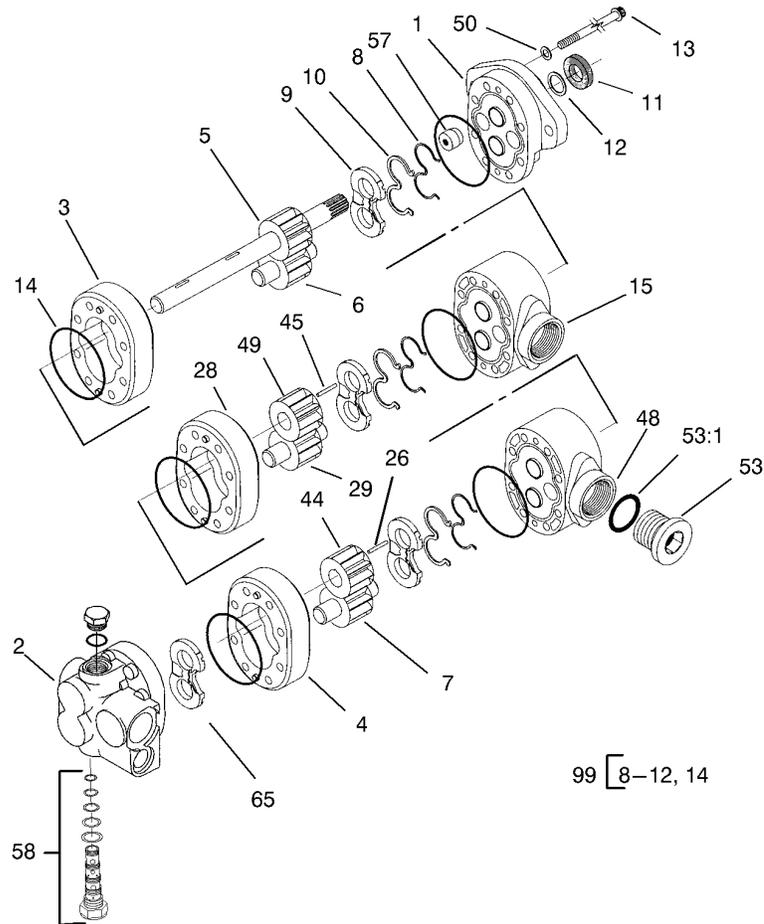

Triple Pump Assembly No. 105-9845

Ref	Part No.	Qty.	Description
1		1	Front Plate ASM
2		1	Back Plate ASM
3		1	Body
4		1	Body
5		1	Drive Gear ASM
6		1	Gear-Idler
7		1	Gear-Idler
8		3	Gasket-Backup
9		3	Plate-Wear
10		3	Seal-Pressure, Balance
11	49-2640	1	Seal-Shaft
12	60-5890	1	Washer
13	105-9849	8	Capscrew
14	105-2866	6	O-Ring
15		1	Plate-Adaptor
26		1	Key
28		1	Body
29		1	Gear-Idler
44		1	Gear
45		1	Key
48		1	Plate-Adaptor
49		1	Gear
50	105-9850	4	Washer-Copper
53	94-3013	1	Plug

Ref	Part No.	Qty.	Description
53:1		1	Seal-Dust
57	94-3011	1	Plug
58	107-1970	1	Valve-Proportional
65		1	Plate-Thrust
99	105-2868	1	Seal Kit

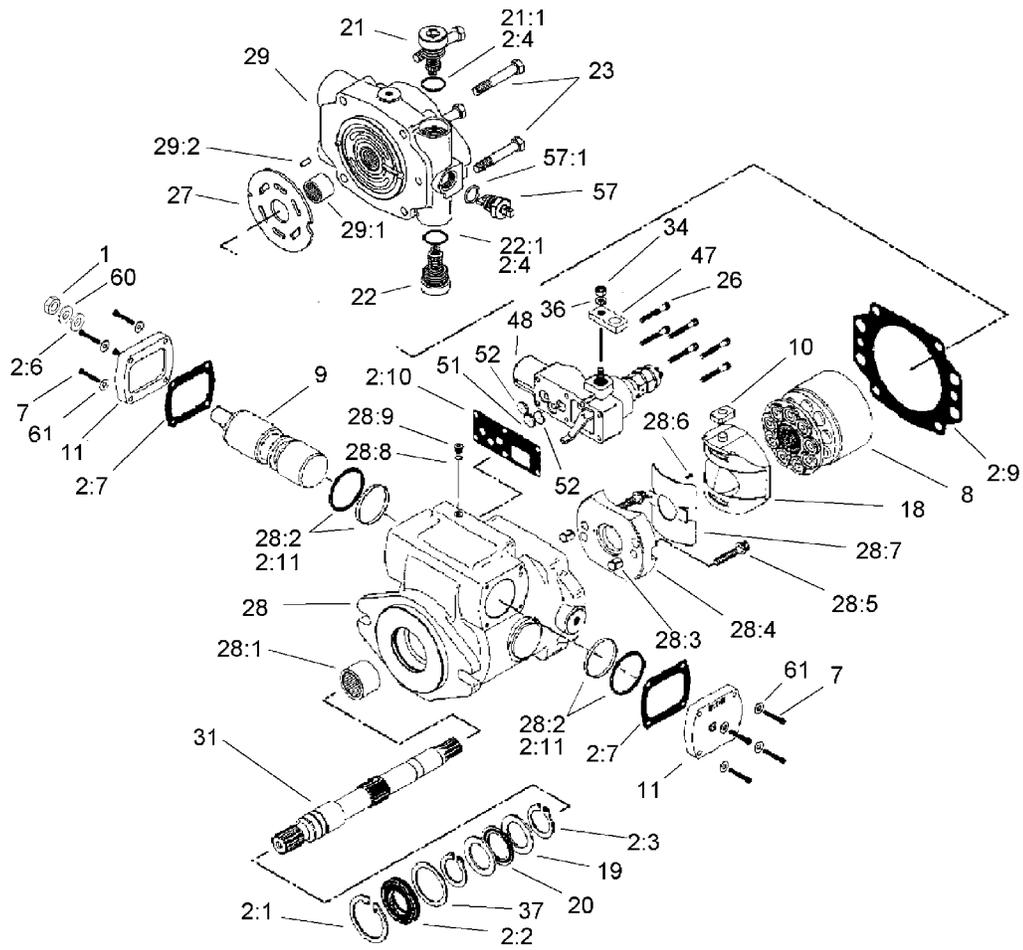

Piston Pump Assembly No. 105-9846

Ref	Part No.	Qty.	Description
1	3220-2	1	Nut-Jam
2	107-1561	1	Seal Kit
2:1	60-6260	1	Ring
2:2	105-3331	1	Seal-Shaft
2:3	76-7000	2	Ring-Retaining
2:4		2	Seal-Dust
2:5	93-6314	2	O-Ring
2:6	94-3027	1	Washer-Seal
2:7	93-6339	2	Gasket
2:8	93-6376	1	O Ring
2:9	105-2900	1	Gasket-Housing
2:10	105-2901	1	Gasket-Housing, Control
2:11		2	Seal ASM
2:12	74-9380	1	O-Ring
7	3274-81	8	Screw-HSH
8	105-9851	1	Rotating Kit
9	105-4572	1	Servo Piston ASM
10	94-3032	1	Follower-Piston
11	105-9853	1	Plate-Cover
18	94-3026	1	Camplate ASM
19	76-6950	2	Race-Thrust
20	76-6960	1	Bearing-Thrust
21	105-2857	1	Valve-Relief
21:1		1	Seal-Dust

Ref	Part No.	Qty.	Description
22	105-2857	1	Valve-Relief
22:1		1	Seal-Dust
23	323-45	4	Screw-HH
26	3274-59	6	Screw-HSH
27	105-9854	1	Plate-Valve
28	105-9855	1	Housing ASM
28:1		1	Bearing
28:2		2	Seal ASM
28:3		2	Dowel-Bushing
28:4		1	Cradle ASM
28:5		2	Screw
28:6		1	Screw
28:7		1	Bushing
28:8		1	Seal-Dust
28:9		1	Plug
29	105-9856	1	Backplate ASM
29:1		1	Bearing
29:2		1	Pin-Roll
31	105-2861	1	Shaft-Drive
34	3217-5	1	Nut-Hex
36	3253-3	1	Washer-Lock
37	60-6240	1	Washer
47	94-3031	1	Arm-Control
48	93-6306	1	Control ASM

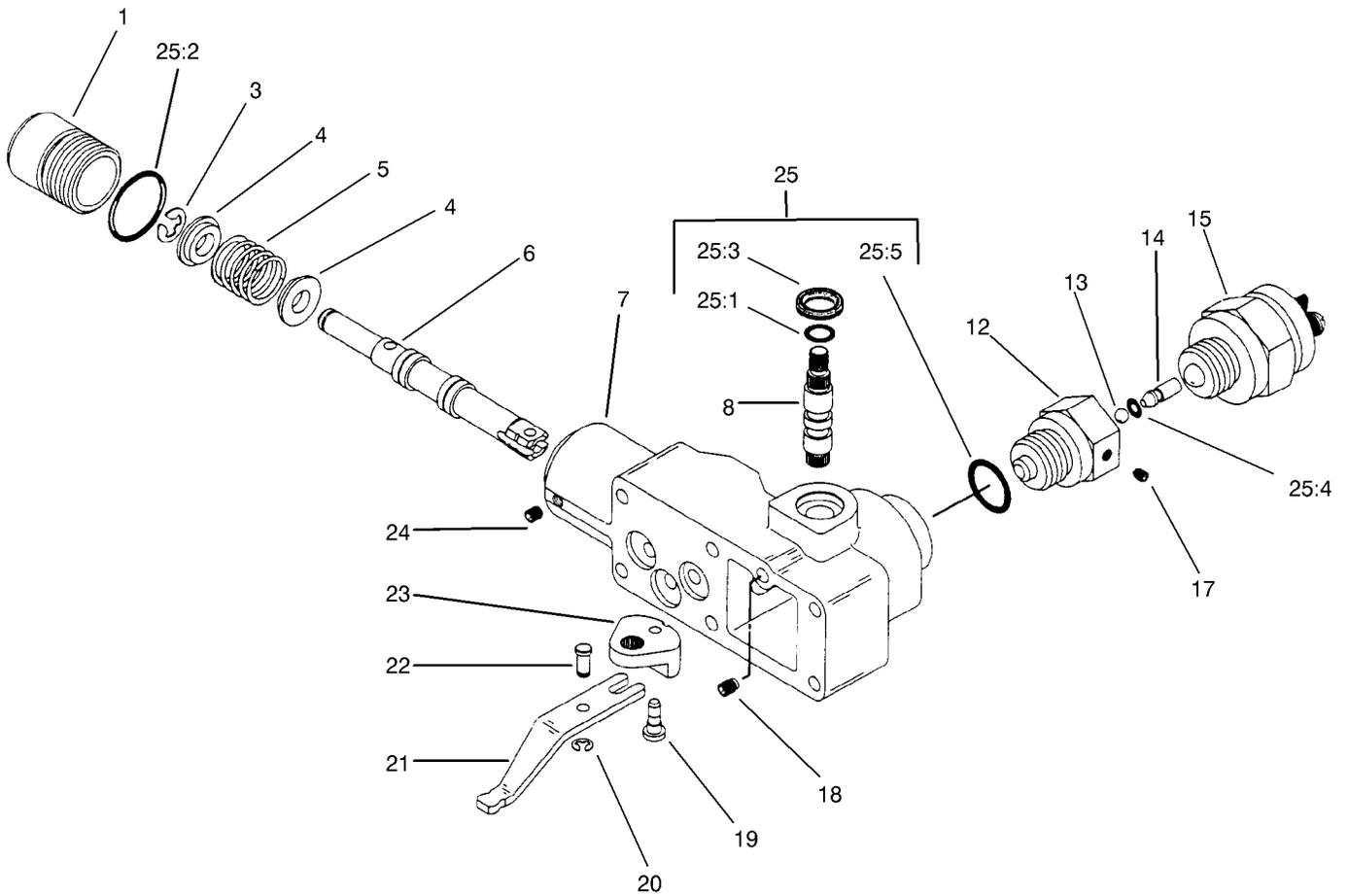

Control Assembly No. 93-6306

Ref	Part No.	Qty.	Description
21		1	Plug
23		1	Ring-Retaining
24		2	Retainer-Spring
25		1	Spring
26		1	Valve-Spool
27		1	Housing-Control
28		1	Shaft-Input
12		1	Adaptor
13		1	Ball
14		1	Pin
15	94-3043	1	Switch-Safety, Neutral
17		1	Screw-Set
18		1	Screw-Set
19		1	Pin
20		1	Ring-Retaining
21		1	Link
22		1	Pin-Dowel
23		1	Crank-Bell
24		1	Screw-Set
25	94-3044	1	Seal Kit
25:1		1	Seal-Dust
25:2		1	Seal-Dust
25:3		1	Seal-Wiper
25:4		1	Seal-Dust
25:5		1	Seal-Dust

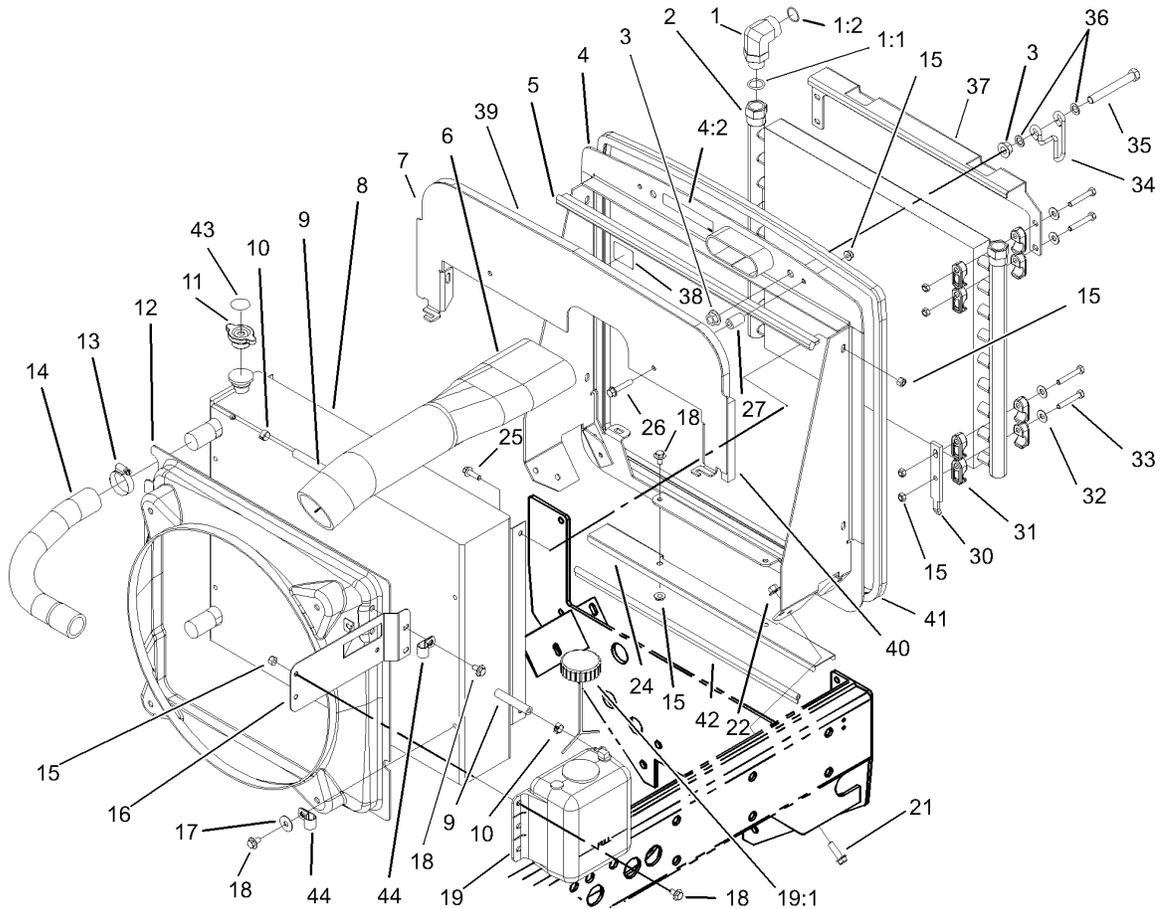

Radiator Assembly

Ref	Part No.	Qty.	Description
1	104-3796	2	Fitting-HYD, 90 DEG
1:1	237-81	1	O-Ring
1:2	340-65	1	O-Ring
2	99-5495	1	Cooler-Oil
3	32128-49	4	Nut-HHF
4	105-3994	1	Bracket-Radiator
4:2	93-7272	1	Decal-Warning
5	104-2223	1	Seal-Bulb
6	100-5550	1	Hose-Cleaner, Air
7	105-3934-03	1	Bracket-Seal, Hood
8	99-5426	1	Radiator
9	71-3370	2	Hose
10	92-2379	3	Clamp-Hose
11	93-5957	1	Cap-Radiator
12	99-5428	1	Shroud-Radiator
13	2412-111	4	Clamp
14	100-5547	2	Hose-Radiator
15	104-8300	19	Nut-Flange, NI
16	100-5505-03	1	Bracket-Tank
17	99-2900	4	Washer-Flat
18	3234-7	11	Screw-HHF
19	104-2276	1	Reservoir-Coolant
19:1	87-7050	1	Cap-Reservoir
21	3234-11	4	Screw-HHF

Ref	Part No.	Qty.	Description
22	32128-43	4	Nut-Flange
24	104-5426-03	1	Cover-Bottom
25	3234-17	4	Screw-HHF
26	94-5780	2	Screw-HWH
27	93-6981	2	Spacer
30	104-5460-03	2	Plate-Mount, Oil Cooler
31	105-3943	16	Clamp-Cooler, Oil
32	3256-23	14	Washer-Flat
33	322-10	8	Screw-HH
34	104-5429	2	Clamp-Form, Wire
35	325-17	2	Screw-HH
36	41-8440	4	Washer
37	104-5428	1	Bracket-Oil Cooler, Top
38	93-7275	1	Decal-Fluid, Starting
39	105-9233	1	Seal-Foam
40	105-9236	2	Seal-Foam
41	105-9814	1	Seal-Bulb
42	105-9858	1	Seal-Bulb
43	106-6755	1	Decal-Cap, Radiator
44	2412-81	2	Clamp-R

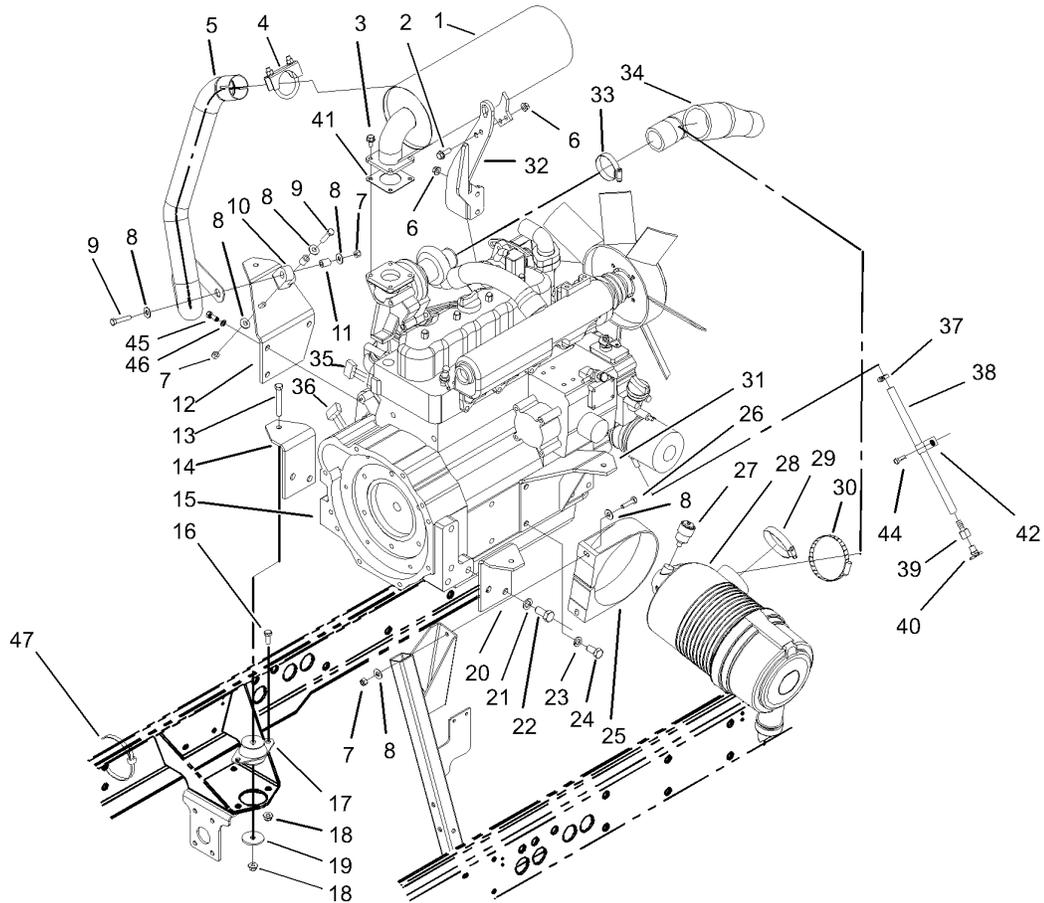

Engine Installation Assembly

Ref	Part No.	Qty.	Description
1	99-5424	1	Muffler-Turbo
2	33104-025	2	Screw-HHF
3	33104-016	4	Screw-HHF
4	18-2130	1	Clamp ASM
5	104-5461	1	Pipe-Exhaust
6	33004-00	4	Nut-HF
7	3296-29	4	Nut-Lock, NI
8	3256-3	8	Washer-Flat
9	322-9	2	Screw-HH
10	95-5622	1	Hanger-Rubber
11	93-5023	2	Spacer
12	106-2048-03	1	Mount-Engine, RH
13	323-13	4	Screw-HH
14	100-3148-03	1	Mount-Engine, RH
15	99-5413	1	Engine-Turbo, Kubota
16	3234-11	10	Screw-HHF
17	53-9682	4	Support-Engine, Rubber
18	104-8301	14	Nut-Flange, NI
19	63-7400	4	Washer-Rebound
20	100-3147-03	1	Mount-Engine, LH
21	43-5950	4	Washer-Lock, Spring
22	43-3210	4	Screw-HH
23	48-8070	5	Washer-Lock
24	42-9250	5	Bolt

Ref	Part No.	Qty.	Description
25	99-5414	1	Strap-Cleaner, Air
26	322-6	2	Screw-HH
27	104-3563	1	Indicator
●27:1	94-1416	1	Indicator Adapter ASM
28	99-5410	1	Cleaner-Air
29	2412-125	1	Clamp-Hose
30	2412-110	1	Clamp-Hose
31	106-2049-03	1	Mount-Engine, LH
32	99-5421-03	1	Bracket-Mounting
33	2412-92	1	Clamp-Hose
34	99-5415	1	Hose-Cleaner, Air
35	99-3441	1	Harness-Wire, Fusible Link
36	105-9869	1	Harness-Wire, Engine
37	2412-108	2	Clamp-Worm
38	99-7376	1	Hose-Breather
39	354-94	1	Fitting-Female, Barbed
40	93-5528	1	Fitting-Cock, Drain
41	100-9333	1	Gasket-Muffler
42	2412-150	1	Clip-J
44	32144-14	1	Screw-HWHTF
45	43-0090	1	Screw-HH
46	48-9590	1	Washer-Lock
47	3290-378	1	Tie-Cable

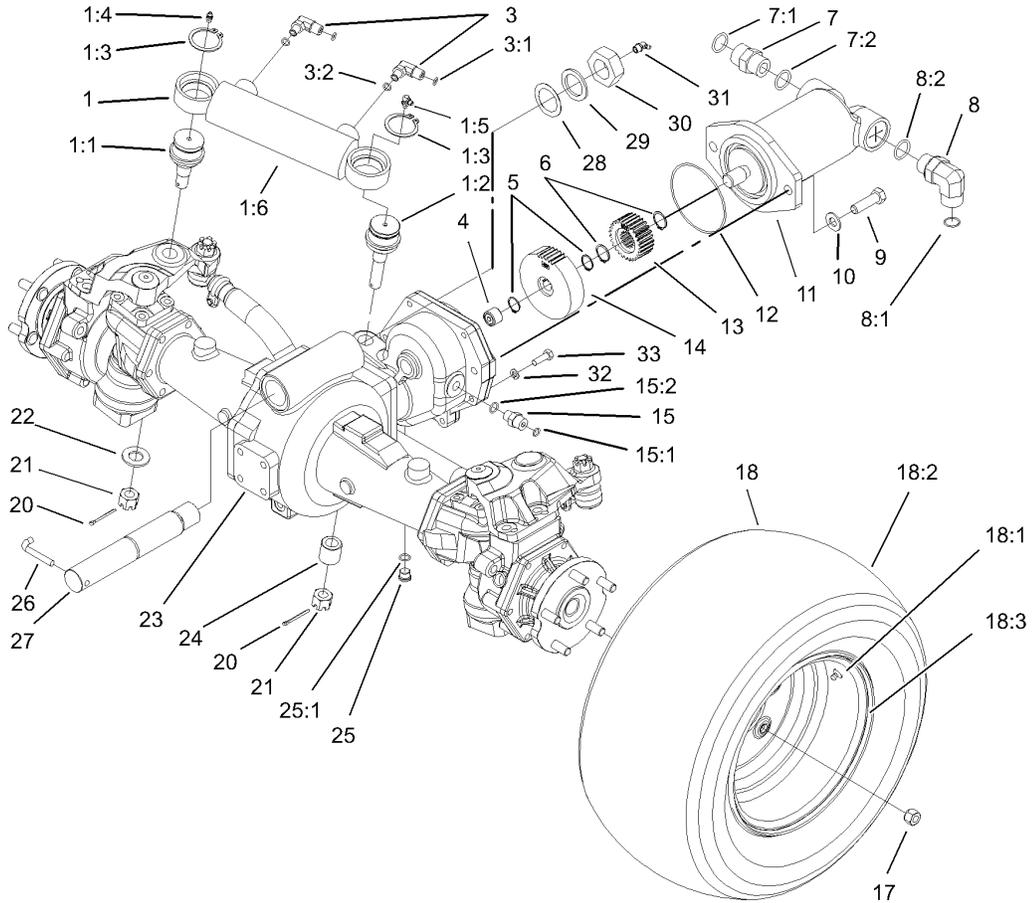

Rear Axle Assembly

Ref	Part No.	Qty.	Description
1	105-9861	1	Steering Cylinder ASM
1:1	106-6774	1	Joint-Ball
1:2	100-3795	1	Joint-Ball
1:3	32151-104	2	Ring-Retaining, External
1:4	302-5	1	Fitting-Grease
1:5	302-60	1	Fitting-Grease, 90 DEG
1:6	340-97	1	HYD Cylinder ASM
3	340-97	2	Fitting-HYD, 90 DEG
3:1	237-22	1	O-Ring
3:2	237-78	1	O-Ring
4	74-5700	1	Bearing-Needle, Roller
5	32120-15	2	Ring-Snap, EXT
6	32120-76	2	Ring-Snap, EXT
7	340-9	1	Fitting-Straight
7:1	237-58	1	O-Ring
7:2	237-81	1	O-Ring
8	340-142	1	Fitting-HYD, 90 DEG
8:1	237-58	1	O-Ring
8:2	237-81	1	O-Ring
9	325-7	2	Screw-HH
10	3256-26	2	Washer-Flat
11	105-1219	1	Motor-Piston
12	237-166	1	O-Ring
13	104-5663	1	Pinion-28T

Ref	Part No.	Qty.	Description
14	104-5664	1	Gear-44T
15	340-2	1	Fitting-HYD, Straight
15:1	237-22	1	O-Ring
15:2	237-42	1	O-Ring
17	93-5268	10	Nut-Lug
18	340-97	2	Tire And Wheel ASM
18:1	232-27	1	Stem-Valve
18:2	104-0451	1	Tire-Turf, Trac
18:3	105-9219	1	Wheel
20	3272-12	2	Pin-Cotter
21	32136-14	2	Nut-SHH
22	92-5836	1	Washer
23	100-3784	1	Drive Axle ASM
24	100-3796	1	Spacer-Joint, Ball
25	353-989	1	Plug-Hex, Hollow
25:1	237-42	1	O-Ring
26	100-3771	1	Pin-Stop
27	100-3770	1	Pin-Axle, Pivot
28	92-1765	1	Washer-Thrust
29	98-3867	2	Washer-Thrust
30	3296-68	1	Nut-Lock, NI
31	302-33	1	Fitting-Grease
32	3253-4	6	Washer-Lock
33	33114-025	6	Screw-HH

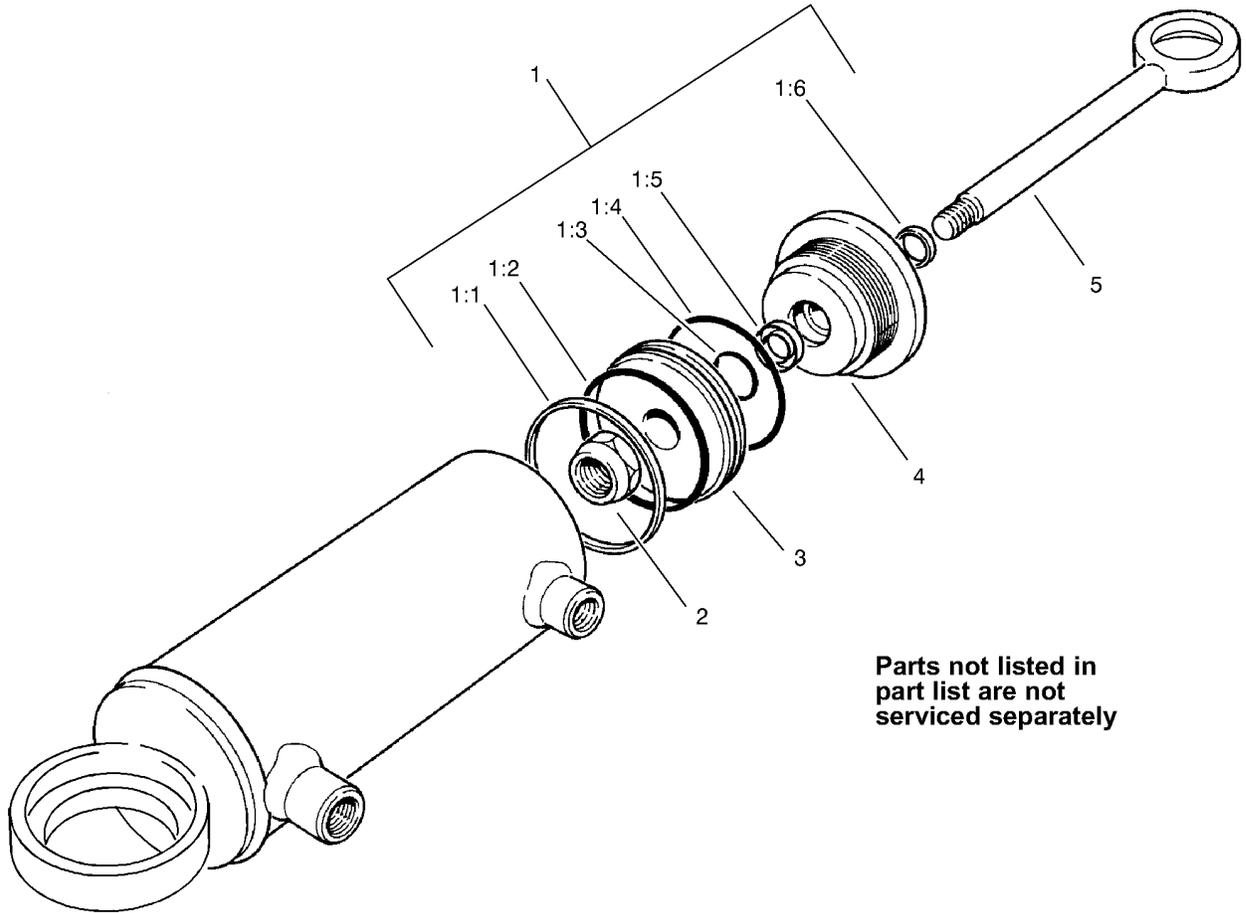

Cylinder Assembly No. 105-9861

Ref	Part No.	Qty.	Description
1	92-6593	1	Seal Kit
②1:1		1	Seal ASM
②1:2		1	Seal-Dust
②1:3		1	Seal-Dust
②1:4		1	Seal-Dust
②1:5		1	U-Cup
②1:6		1	Wiper
②2		1	Locknut
②3		1	Piston
②4		1	Gland
②5		1	Rod ASM

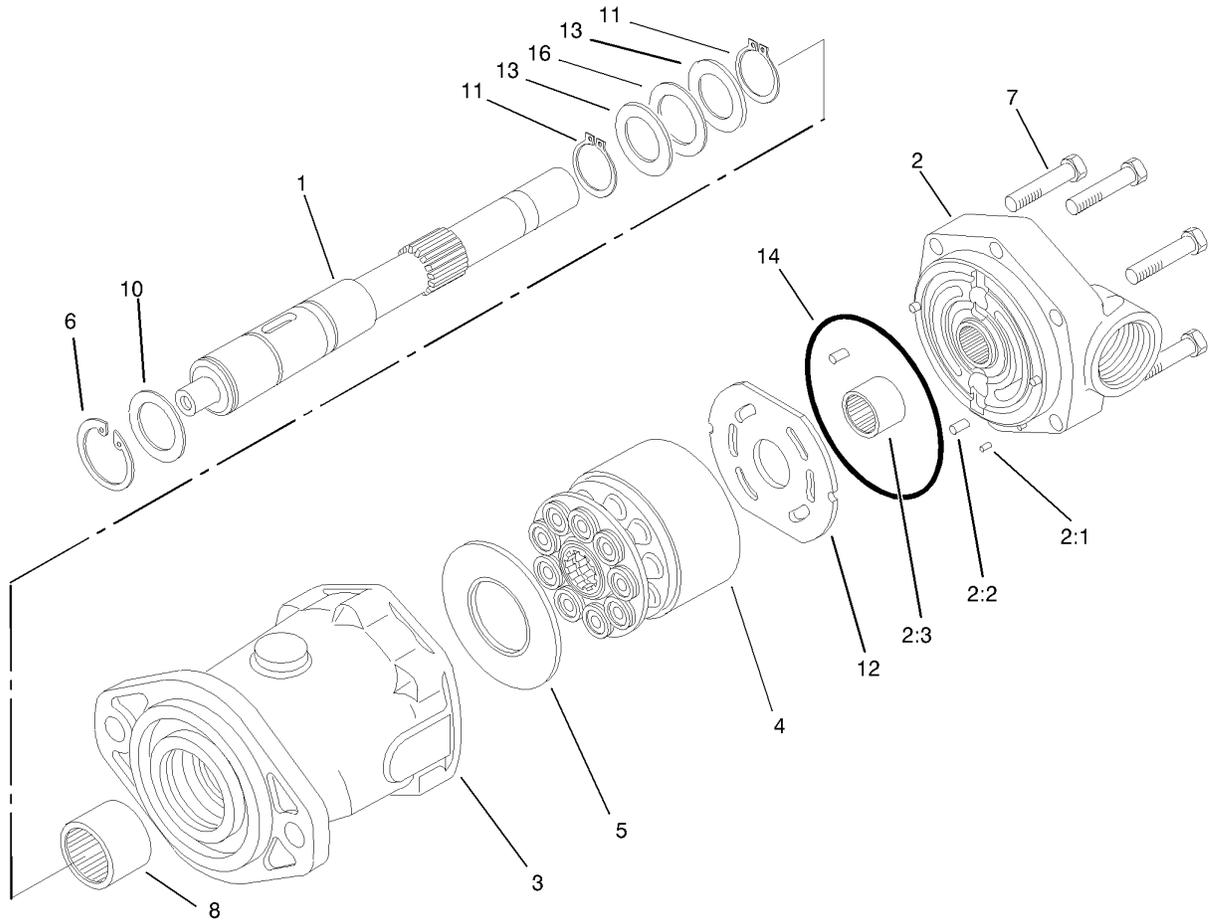

Piston Motor Assembly No. 105-1219

Ref	Part No.	Qty.	Description
1	105-2853	1	Shaft-Drive
2	100-2551	1	Backplate
2:1		3	Pin-Dowel
2:2		1	Pin-Dowel
2:3		1	Bearing-Needle
2:3		1	Housing
4	76-6910	1	Rotating Kit
5	76-6970	1	Insert-Plate, Cam
6	60-6260	1	Ring
7	94-3002	6	Capscrew
8	63-4390	1	Bearing-Needle
10	76-7020	1	Spacer
11	76-7000	2	Ring-Retaining
12	94-3003	1	Plate-Valve
13	76-6950	2	Race-Thrust
14	76-6980	1	O-Ring
16	60-6170	1	Bearing-Thrust

--	--	--	--

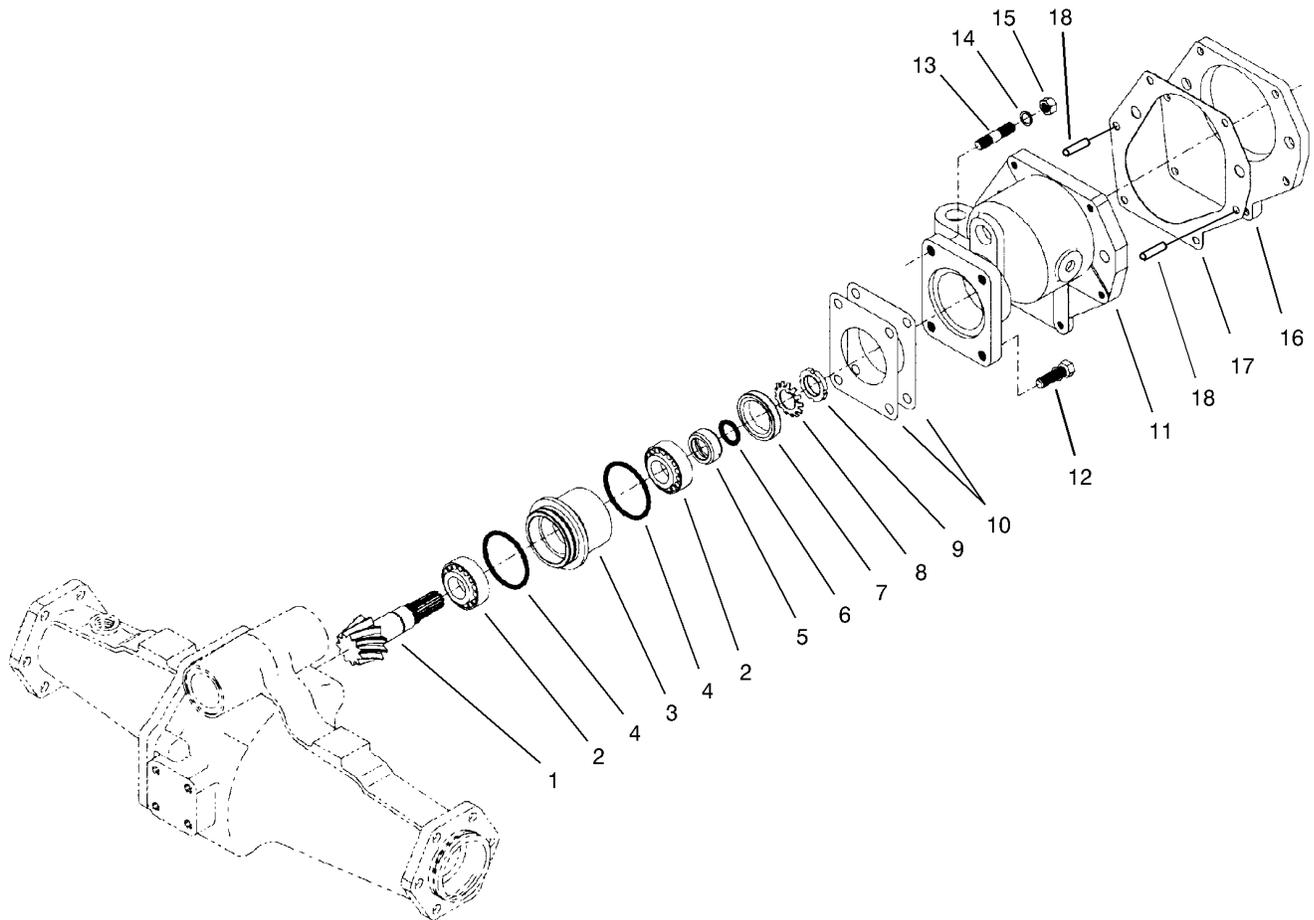

Bevel Pinion Shaft Assembly Rear Axle Assembly No. 100-3784

Ref	Part No.	Qty.	Description
1	100-2555	1	Ring And Pinion Matched Set
2	99-7570	2	Bearing-Roller, Taper
3	95-7534	1	Case-Bearing
4	99-7571	2	O-Ring
5	99-7572	1	Collar-Seal, Oil
6	99-7573	1	O-Ring
7	99-7574	1	Seal-Oil
8	99-7559	1	Washer-Lock
9	99-7560	1	Nut-Lock
10	99-7550	2	Shim 0.1
10	99-7551	2	Shim 0.2
11	95-7533	1	Case-Gear
12	99-7575	2	Bolt
13	98-7735	2	Stud
14	99-7527	2	Washer-Spring
15	99-7526	2	Nut
16	95-7541	1	Plate-Cover
17	95-7540	1	Gasket
18	104-2353	2	Pin-Dowel

--	--	--	--

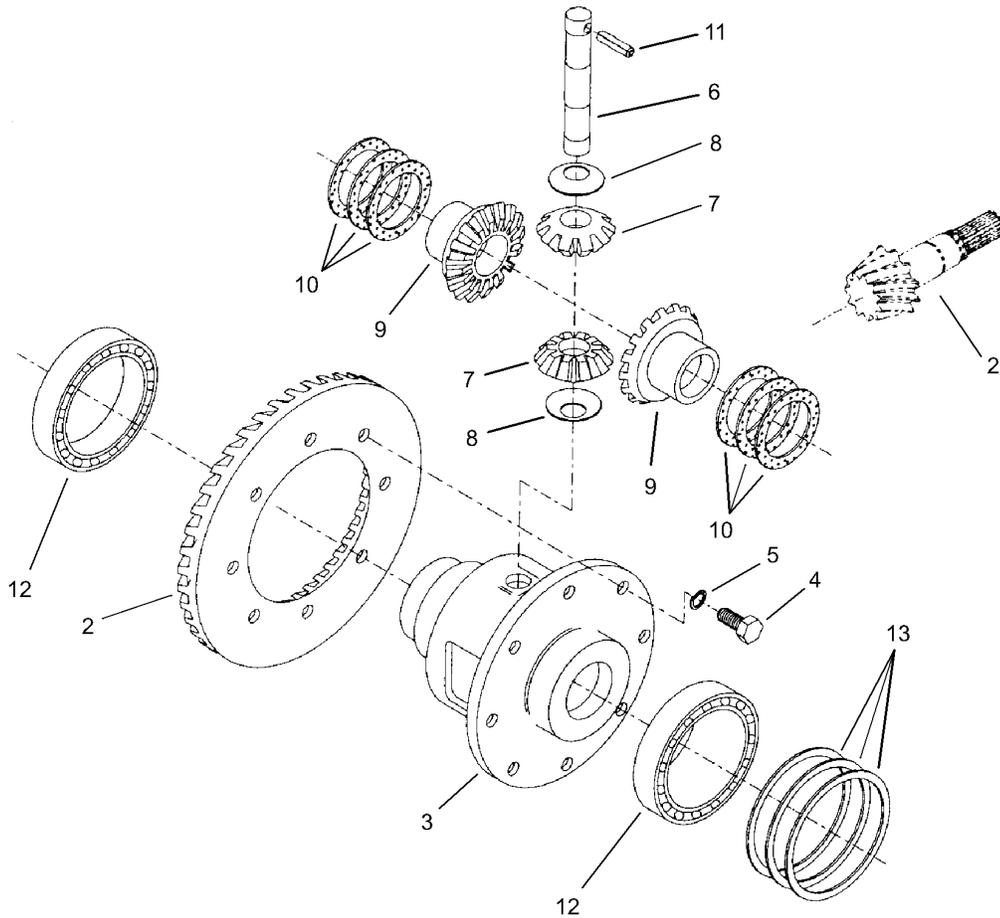

Differential Assembly Rear Axle Assembly No. 100-3784

Ref	Part No.	Qty.	Description
1	95-7503	1	Differential ASM
2	100-2555	1	Ring And Pinion Matched Set
3	95-7502	1	Case-Differential
4	99-7576	8	Bolt
5	99-7577	8	Washer-Spring
6	99-7578	1	Shaft-Differential
7	99-7579	2	Pinion-Differential
8	99-7580	2	Washer-Differential
9	99-7581	2	Gear-Differential
10	99-7582	2	Washer-Differential
10	99-7583	2	Washer-Differential
10	99-7584	2	Washer-Differential
11	99-7588	1	Pin-Spring
12	99-7562	2	Bearing-Ball
13	99-7585	2	Shim 0.1
13	99-7586	2	Shim 0.2
13	99-7587	2	Shim 0.4

--	--	--	--

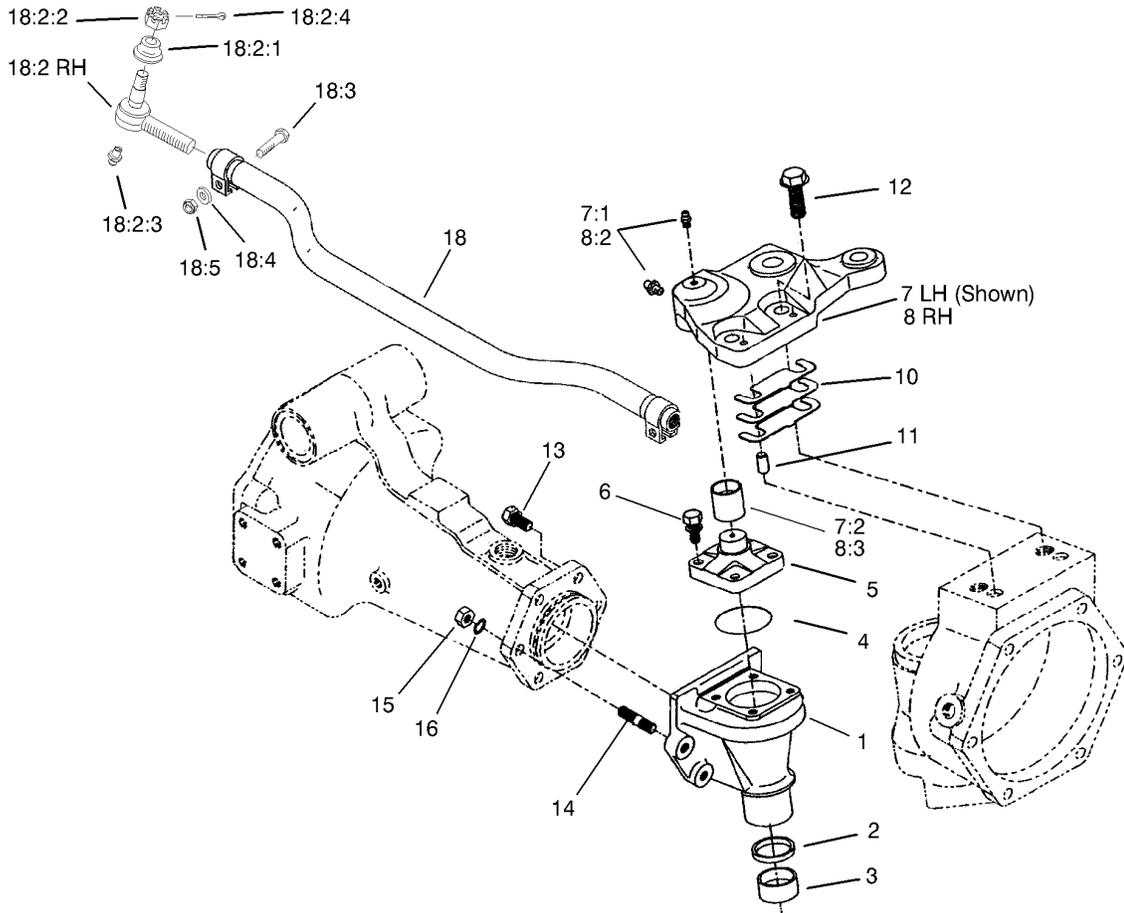

Bevel Gear Case Assembly Rear Axle Assembly No. 100-3784

Ref	Part No.	Qty.	Description
1	95-7538	2	Case-Gear, Bevel
2	100-2557	2	Seal-Oil
3	104-2378	2	Bushing
4	104-2372	2	O-Ring
5	104-2373	2	Knuckle
6	104-2374	8	Bolt
7	100-3768	1	LH Steering Arm ASM
7:1	302-5	2	Fitting-Grease
7:2	104-8634	1	Bushing
8	100-3766	1	RH Steering Arm ASM
8:2	302-5	2	Fitting-Grease
8:3	104-8634	1	Bushing
10	95-7547	2	Shim 0.1
10	95-7548	2	Shim 0.2
10	95-7549	2	Shim 0.3
11	99-7597	4	Pin-Dowel
12	104-2375	4	Bolt
13	99-7599	8	Bolt
14	99-7525	4	Stud
15	99-7526	4	Nut
16	99-7527	4	Washer-Spring
18	100-3762	1	Tie Rod ASM
●18:1	100-3851	1	LH Tie Rod End ASM
●18:1:1	100-3853	1	Cover-Dust

Ref	Part No.	Qty.	Description
●18:1:2	100-3854	1	Nut-Castle
●18:1:3	302-5	1	Fitting-Grease
●18:1:4	3272-11	1	Pin-Cotter
18:2	100-3852	1	RH Tie Rod End ASM
18:2:1	100-3853	1	Cover-Dust
18:2:2	100-3854	1	Nut-Castle
18:2:3	302-5	1	Fitting-Grease
18:2:4	3272-11	1	Pin-Cotter
18:3	100-3855	2	Bolt
18:4	99-7527	2	Washer-Spring
18:5	99-7526	2	Nut

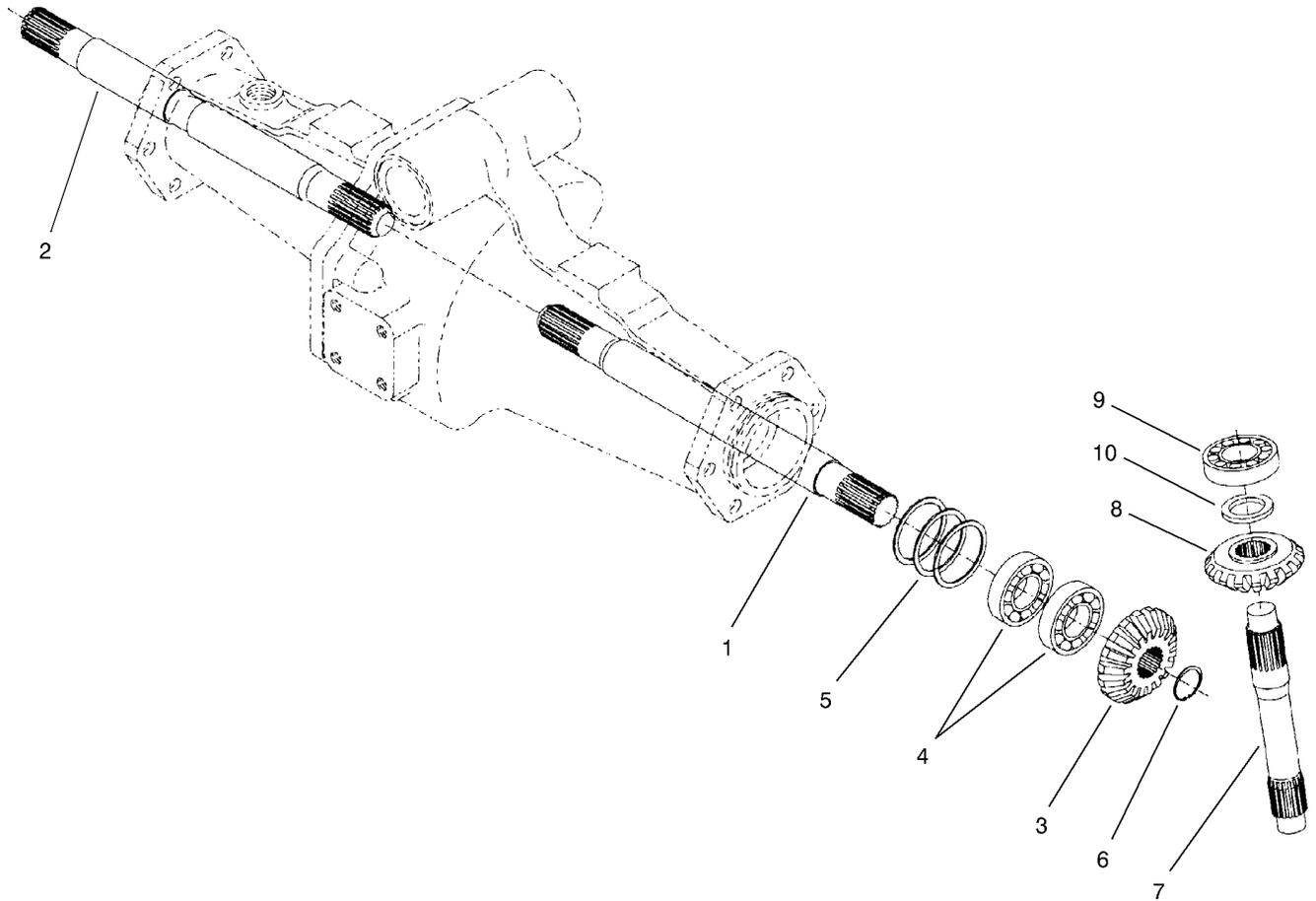

Bevel Gear Shaft Assembly Rear Axle Assembly No. 100-3784

Ref	Part No.	Qty.	Description
1	95-7509	1	Shaft-Gear, Differential
2	95-7512	1	Shaft-Gear, Differential
3	95-7517	2	Gear-Bevel, 15 Tooth
4	99-7530	4	Bearing-Ball
5	99-7552	2	Shim 0.1
5	99-7553	2	Shim 0.2
5	99-7554	2	Shim 0.5
6	99-7531	2	Clip
7	95-7529	2	Shaft-Gear, Bevel
8	95-7519	2	Gear-Bevel, 17 Tooth
9	99-7532	2	Bearing-Roller, Taper
10	99-7558	2	Collar

--	--	--	--

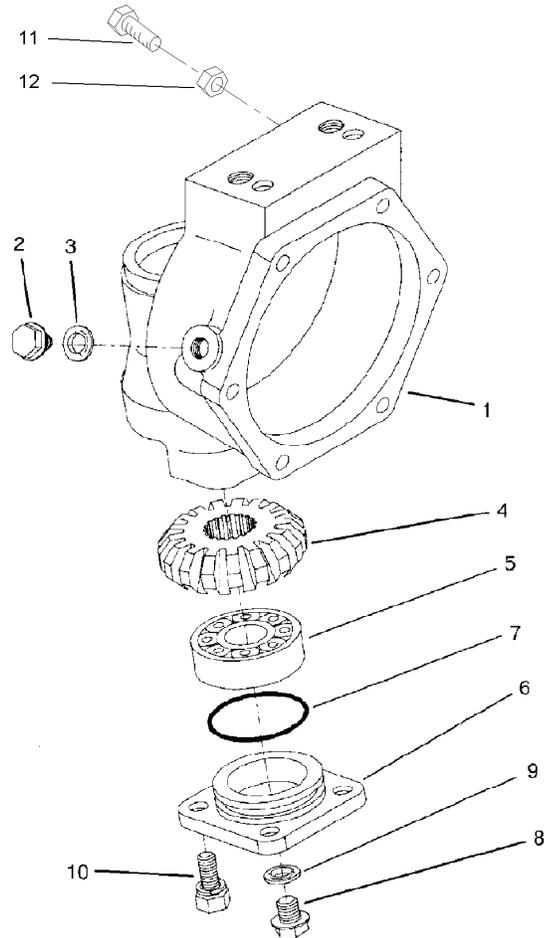

Axle Case Assembly Rear Axle Assembly No. 100-3784

Ref	Part No.	Qty.	Description				
1	95-7531	2	Case-Axle				
2	99-7535	2	Plug				
3	99-7536	2	Washer-Seal				
4	95-7527	2	Gear-Bevel, 17 Tooth				
5	99-7532	2	Bearing-Roller, Taper				
6	100-2560	2	Cover				
7	100-2561	2	O-Ring				
8	99-7589	2	Plug				
9	99-7590	2	Washer-Seal				
10	100-2562	8	Bolt				
11	106-1102	2	Bolt-Stop				
12	106-1103	2	Nut				

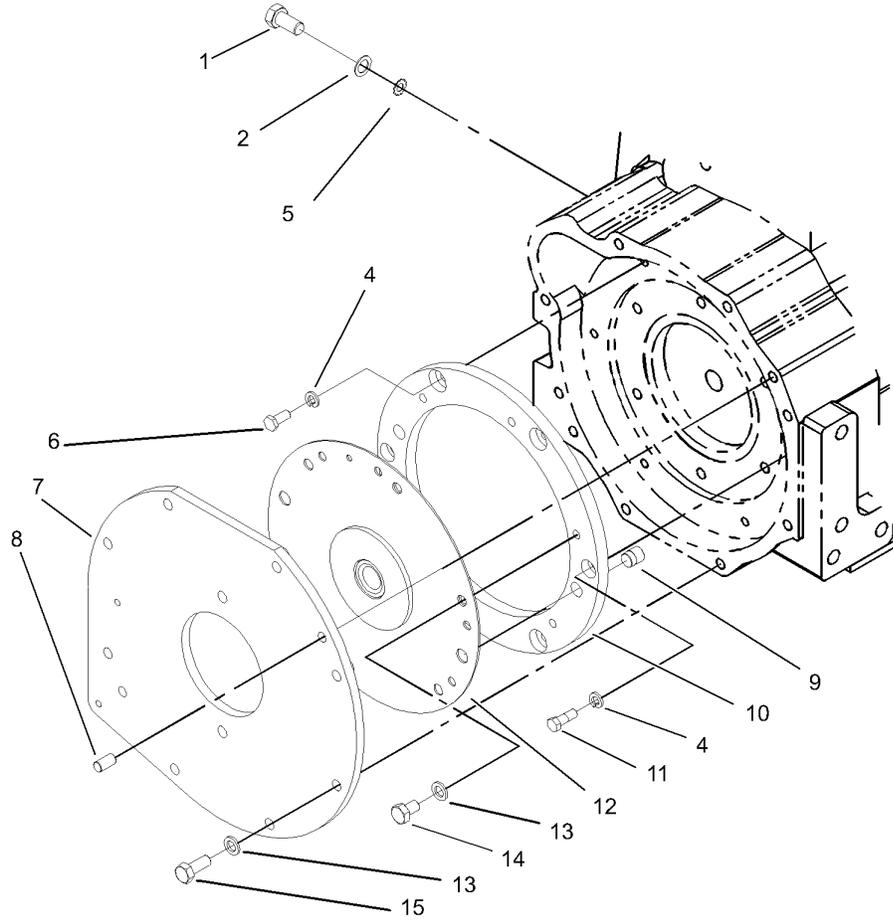

Coupler Spacer and Adapter Plate Assembly

Ref	Part No.	Qty.	Description
1	42-9250	1	Bolt
2	3255-2	1	Washer-Lock / EXT
4	42-9850	6	Washer-Lock, Spring
5	3255-9	1	Washer-Lock
6	33114-020	4	Screw-HH
7	100-5632-03	1	Plate-Adapter
8	98-1212	2	Pin-Plate, Pump
9	58-3590	2	Dowel
10	100-5633	1	Spacer-Coupling
11	100-5634	2	Bolt-Shoulder
12	92-1753	1	Coupling-Spring
13	48-9590	14	Washer-Lock
14	70-8470	6	Screw-HH
15	43-0090	8	Screw-HH

--	--	--	--

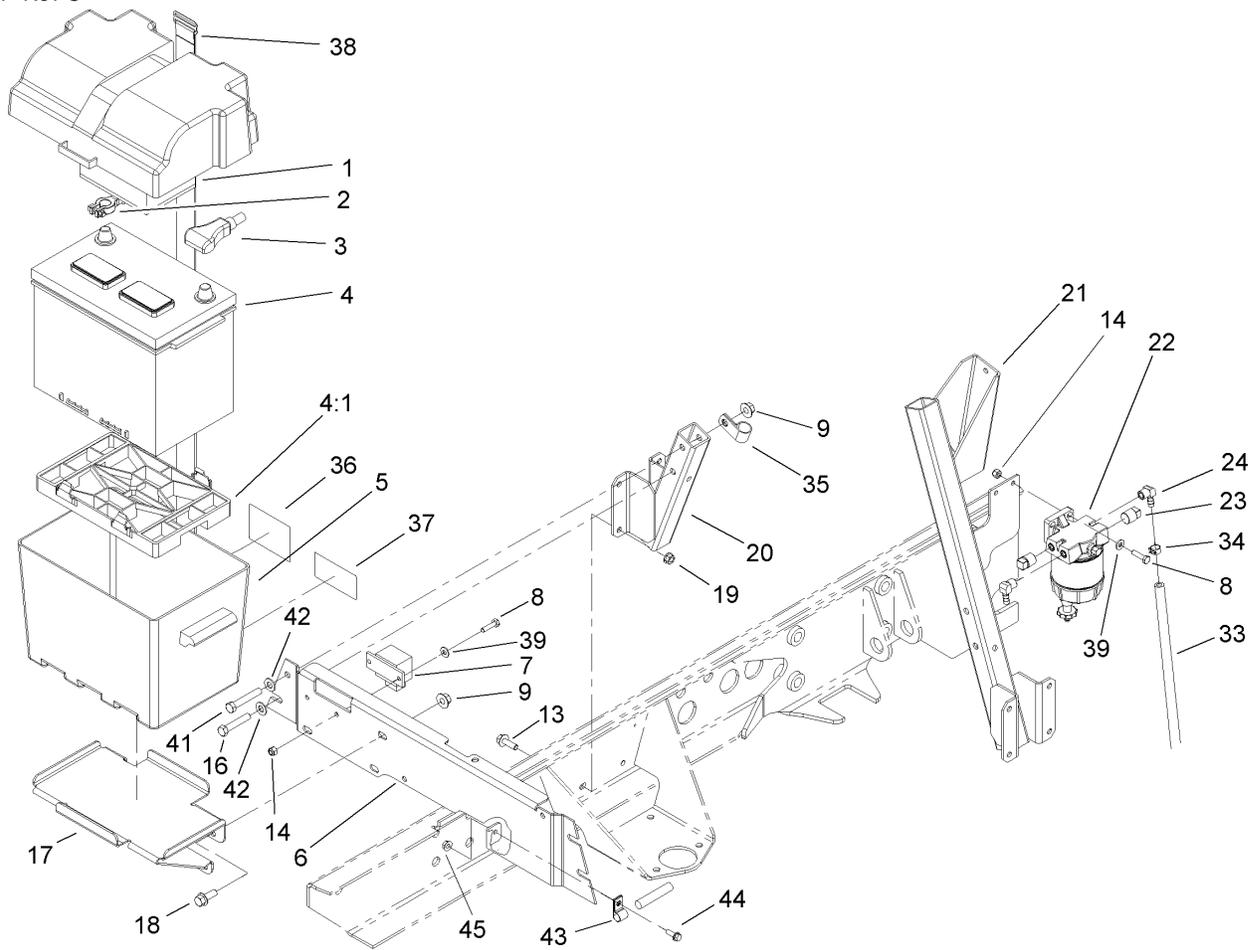

Battery Installation Assembly

Ref	Part No.	Qty.	Description
1	93-7968	1	Pad-Foam
2	105-3880	1	Cable-Battery, Negative
3	105-0114	1	Cable-Battery, Positive
24		1	Battery-12 Volt
24:1		1	Adapter-Battery Height
5	93-7595	1	Battery Box ASM
6	104-5422-03	1	Bracket-Support, Battery
7	66-8800	1	Relay
8	321-6	4	Screw-HH
9	32128-43	6	Nut-Flange
13	3234-29	8	Screw-HHF
14	3296-42	4	Nut-Lock, NI
16	323-11	3	Screw-HH
17	104-5423-03	1	Tray-Battery
18	3234-11	2	Screw-HHF
19	32128-20	8	Nut-HF
20	104-5420-03	1	Battery Support ASM
21	104-5417-03	1	Bracket-Conditioner, Air
22	98-9305	1	Water / Fuel Filter ASM
23	281-13	2	Plug-Pipe
24	353-781	2	Fitting-Elbow
33	63-7627	1	Hose-Fuel
34	92-2379	3	Clamp-Hose
35	2412-81	2	Clamp-R

Ref	Part No.	Qty.	Description
36	93-6668	1	Decal-Battery
37	93-7276	1	Decal-Danger
38	94-1445	1	Strap-Battery
39	3256-22	4	Washer-Flat
41	323-12	1	Screw-HH
42	3256-24	4	Washer-Flat
43	2412-93	1	Clamp-R
44	3234-4	1	Screw-HHF
45	32128-33	1	Nut-HF

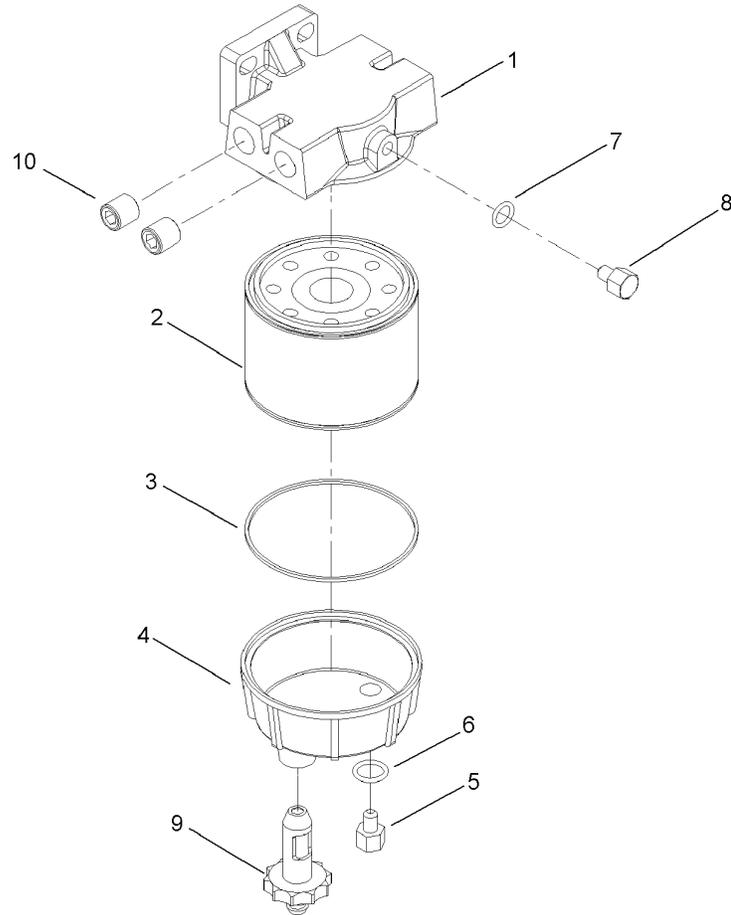

Water and Fuel Filter Assembly No. 98-9305

Ref	Part No.	Qty.	Description	
1	98-9772	1	Head-Filter	
2	98-9764	1	Element	
3	98-9774	1	O-Ring	
4	98-9775	1	Base-Filter	
5	98-9773	1	Plug-Base, Filter	
6	237-42	1	O-Ring	
7	237-78	1	O-Ring	
8	98-9776	1	Plug-Head, Filter	
9	98-9777	1	Drain Valve ASM	
10	285-22	2	Plug-Pipe	

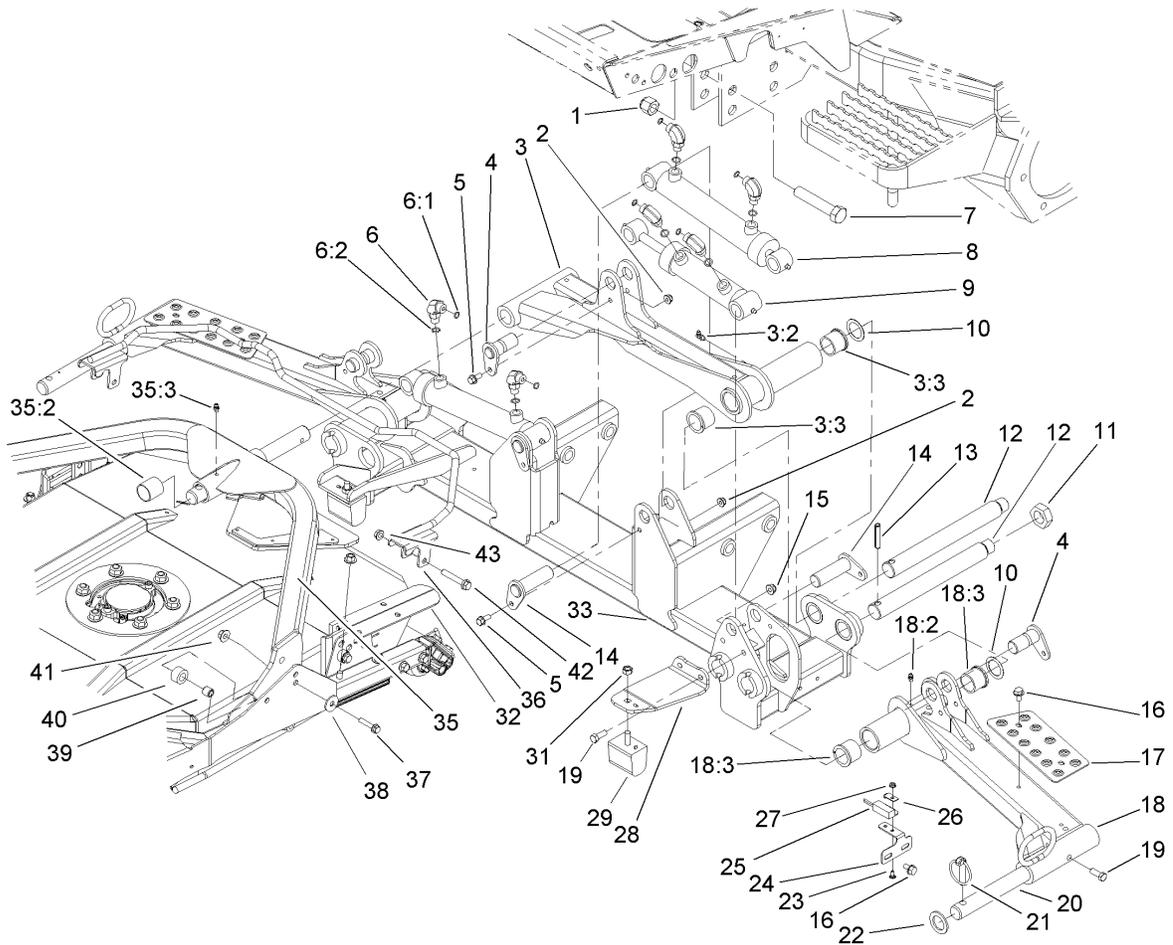

Front Lift Arm Assembly

Ref	Part No.	Qty.	Description
1	3296-51	4	Nut-Lock, NI
2	104-8300	6	Nut-Flange, NI
3	105-9201	1	No. 1 Lift Arm ASM
3:2	302-60	1	Fitting-Grease, 90 DEG
3:3	104-0015	2	Bushing-Flange
4	104-5525	3	Cylinder Pin ASM
5	3234-5	6	Screw-HHF
6	340-77	6	Fitting-HYD, 90 DEG
6:1	237-22	1	O-Ring
6:2	237-42	1	O-Ring
7	328-7	4	Screw-HH
8	104-5527	2	Cylinder-Lift, No. 4 And 5
9	104-5528	1	Cylinder-Lift, No. 1
10	76-2980	3	Washer-Thrust
11	3296-49	3	Nut-Lock, NI
12	95-7158	3	Pin-Pivot
13	32121-110	3	Pin-Roll, Slotted
14	105-9889	3	Cylinder Pin ASM
15	104-8301	2	Nut-Flange, NI
16	32144-14	8	Screw-HWHTF
17	105-3987-03	2	Plate-Skid
18	105-9204	1	No. 4 Lift Arm ASM
18	105-9205	1	No. 5 Lift Arm ASM
18:2	302-5	1	Fitting-Grease

Ref	Part No.	Qty.	Description
18:3	104-0015	2	Bushing-Flange
19	323-6	5	Screw-HH
20	95-8979	3	Shaft
21	283-71	3	Pin-Lynch
22	3-6781	3	Washer-Thrust
23	104-1450	2	Bolt-CARR
24	104-5585	2	Bracket-Switch
25	100-1270	2	Switch-Proximity
26	100-4872	2	Plate-Switch, Neutral
27	32149-7	2	Nut-Keps
28	104-5689-03	1	Bracket-Support, Bumper
29	87-3470	2	Bumper-Axle, Rear
31	33025-00	2	Nut-Lock
32	105-9831-01	2	Bracket-Bumper, No. 1
33	104-5680-03	1	Front Carrier Frame ASM
35	104-5656	5	Carrier Frame ASM
35:2	95-8795	2	Bushing
35:3	302-5	1	Fitting-Grease
36	107-7803-01	4	Guard-Foot ASM
37	3234-18	10	Screw-HHF
38	93-8806	10	Washer-Hardened
39	105-9822	10	Spacer
40	105-9823	10	Bushing-Carrier
41	32128-43	10	Nut-Flange

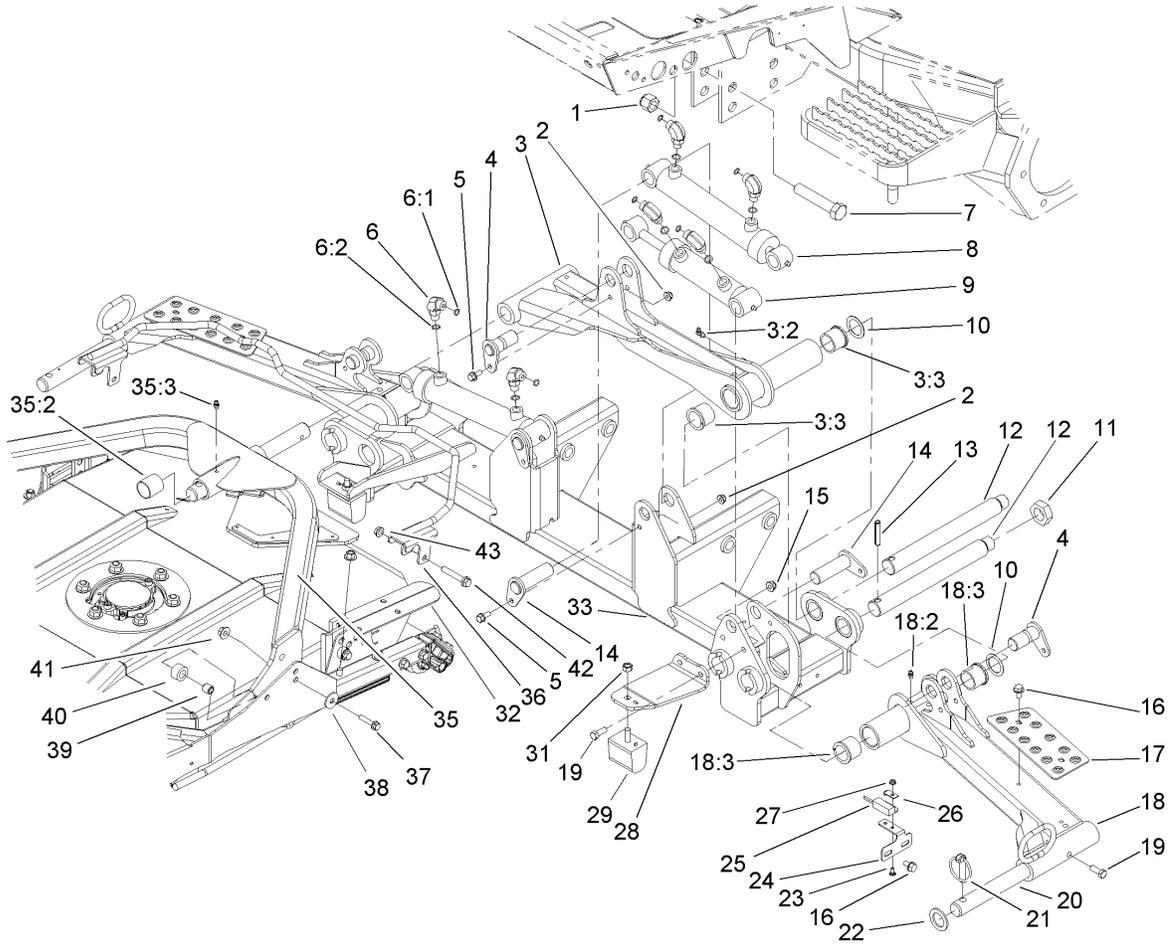

Front Lift Arm Assembly (continued)

Ref	Part No.	Qty.	Description
42	100-2592	8	Screw-HHF
43	3290-357	8	Nut-HHF, Whiz

--	--	--	--

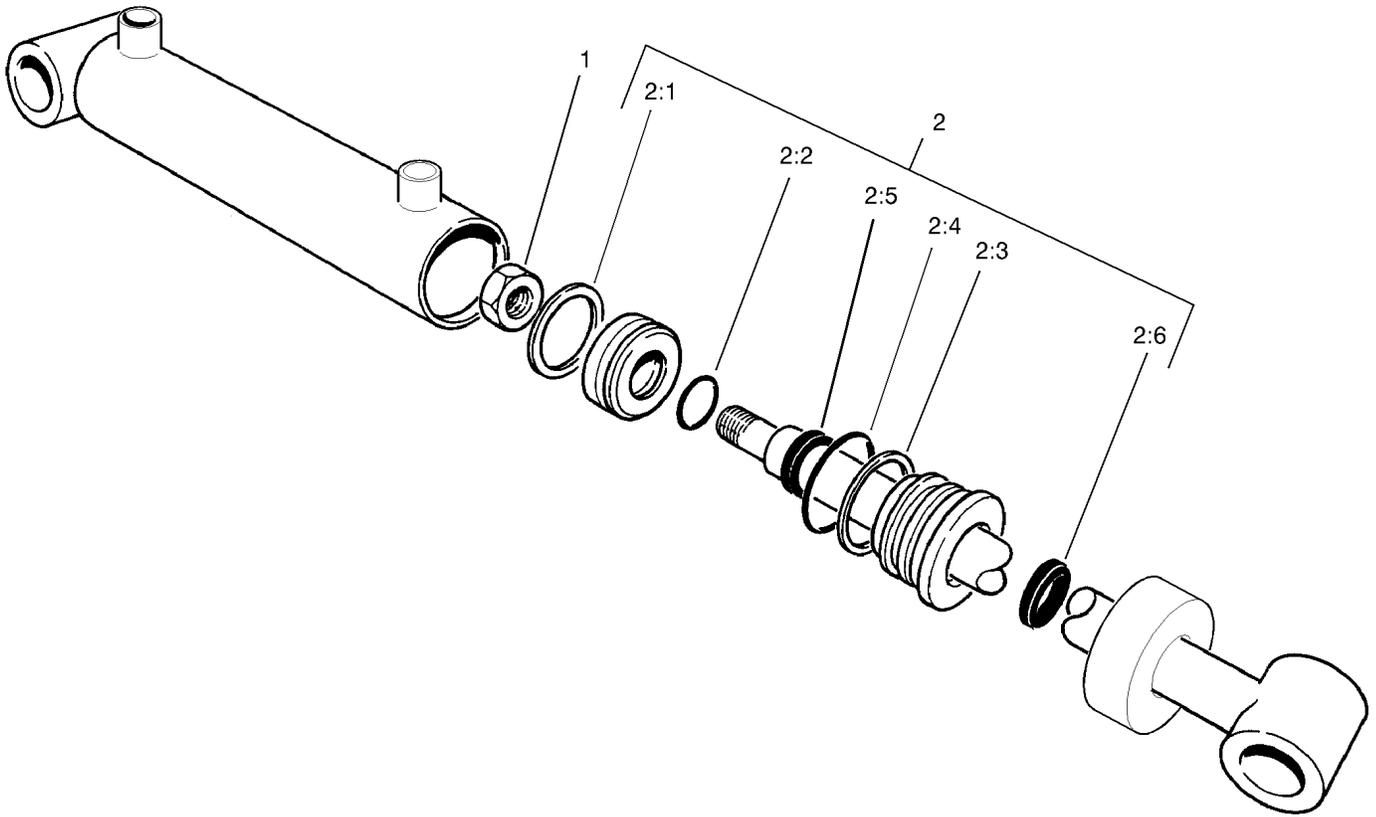

Lift Cylinder Assembly No. 104-5527

Ref	Part No.	Qty.	Description
1	32152-10	1	Locknut
2	104-5847	1	Seal Kit
2:1		2	Seal-Dust
2:2		1	Seal-Dust
2:3		2	O-Ring, Backup
2:4		1	T-Seal
2:5		2	Seal-Rod
2:6		2	Seal-Dust

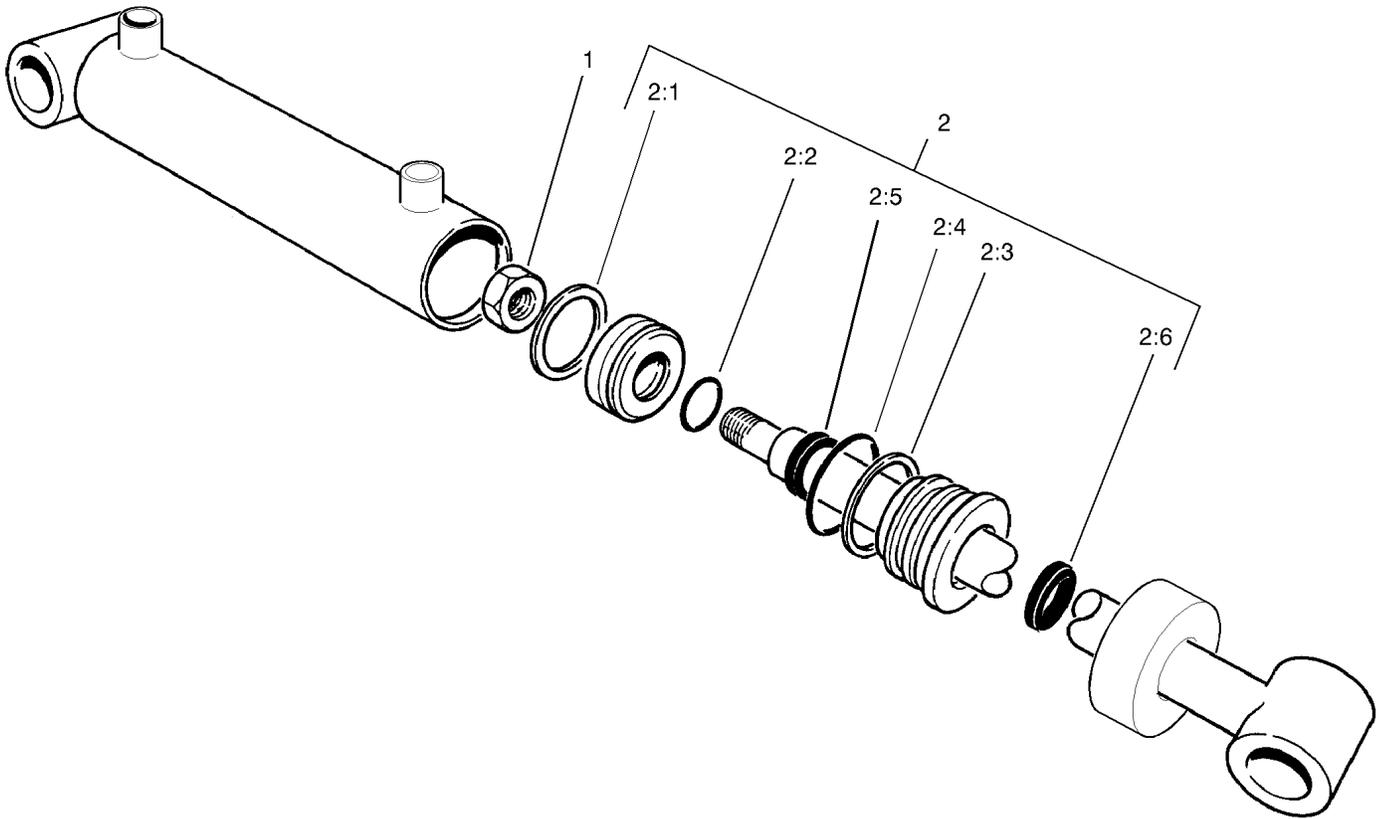

Lift Cylinder Assembly No. 104-5528

Ref	Part No.	Qty.	Description
1	32152-10	1	Locknut
2	104-5847	1	Seal Kit
2:1		2	Seal-Dust
2:2		1	Seal-Dust
2:3		2	O-Ring, Backup
2:4		1	T-Seal
2:5		2	Seal-Rod
2:6		2	Seal-Dust

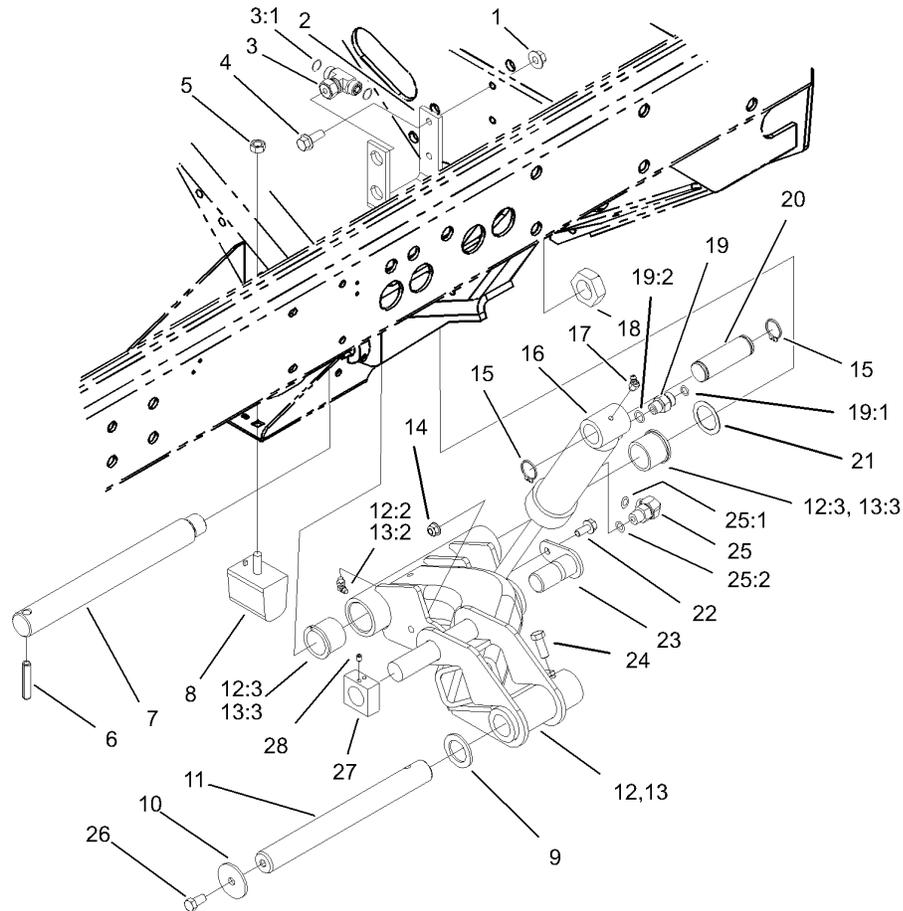

No. 2 and 3 Lift Arm Assembly

Ref	Part No.	Qty.	Description
1	32128-20	2	Nut-HF
2	105-3992-03	1	Bracket-Bulkhead
3	340-166	2	Fitting-Tee, HYD
3:1	237-22	1	O-Ring
4	3234-17	2	Screw-HHF
5	33025-00	2	Nut-Lock
6	32121-110	2	Pin-Roll, Slotted
7	95-7158	2	Pin-Pivot
8	87-3470	2	Bumper-Axle, Rear
9	3-6781	2	Washer-Thrust
10	63-7400	2	Washer-Rebound
11	105-9827	2	Shaft
12	105-9202	1	No. 2 Lift Arm ASM
12:2	302-60	1	Fitting-Grease, 90 DEG
12:3	104-0015	2	Bushing-Flange
13	105-9203	1	No. 3 Lift Arm ASM
13:2	302-60	1	Fitting-Grease, 90 DEG
13:3	104-0015	2	Bushing-Flange
14	104-8300	2	Nut-Flange, NI
15	32151-36	4	Ring-Retaining
16	104-5526	2	Cylinder-Lift, No. 2 And 3
17	302-11	2	Fitting-Lube, 45 DEG
18	3296-49	2	Nut-Lock, NI
19	340-2	2	Fitting-HYD, Straight

Ref	Part No.	Qty.	Description
19:1	237-22	1	O-Ring
19:2	237-42	1	O-Ring
20	92-7548	2	Pin-Cylinder
21	76-2980	2	Washer-Thrust
22	3234-17	2	Screw-HHF
23	104-5525	2	Cylinder Pin ASM
24	323-6	2	Screw-HH
25	340-77	2	Fitting-HYD, 90 DEG
25:1	237-22	1	O-Ring
25:2	237-42	1	O-Ring
26	323-4	2	Screw-HH
27	105-9839	2	Stop-Rotation, No. 2 And 3
28	3245-7	4	Screw-Set

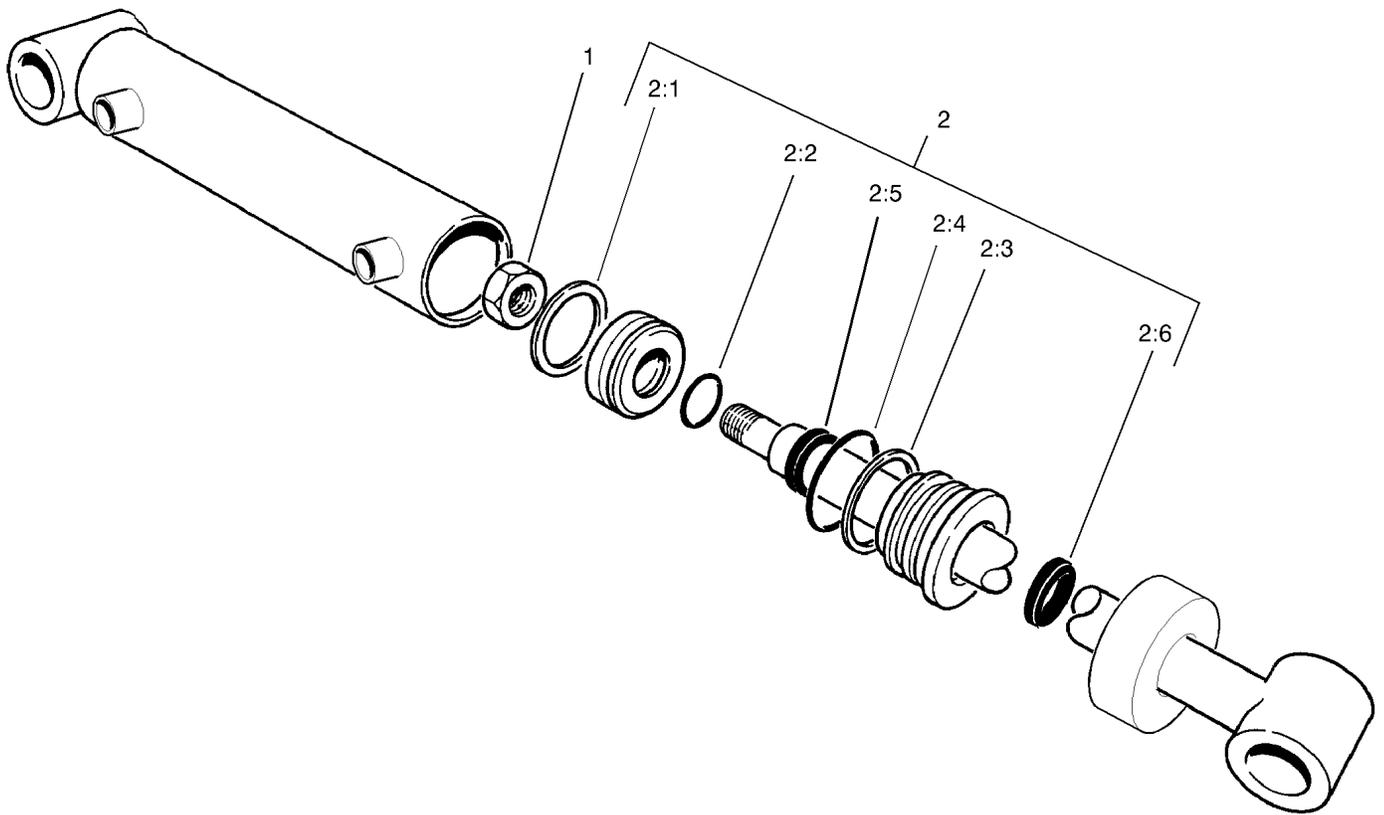

Lift Cylinder Assembly No. 104-5526

Ref	Part No.	Qty.	Description
1	32152-10	1	Locknut
2	104-5847	1	Seal Kit
2:1		2	Seal-Dust
2:2		1	Seal-Dust
2:3		2	O-Ring, Backup
2:4		1	T-Seal
2:5		2	Seal-Rod
2:6		2	Seal-Dust

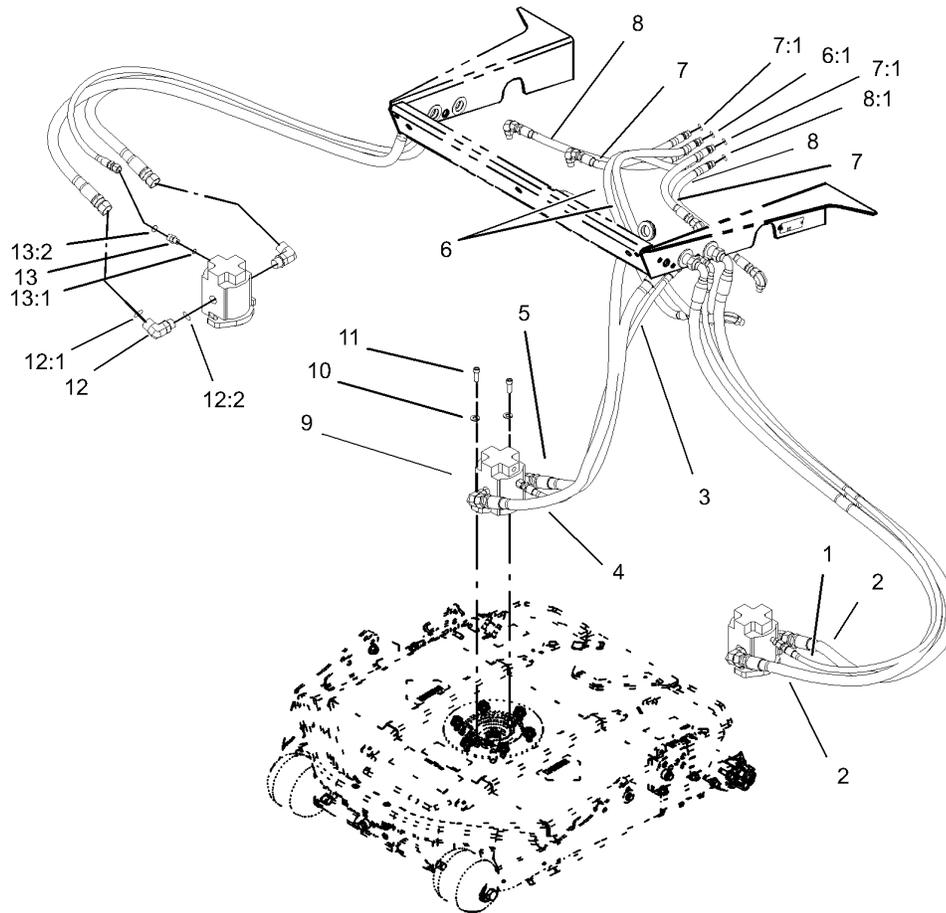

No. 1, 4 and 5 Hose Installation Assembly

Ref	Part No.	Qty.	Description
1	104-5500	2	Hose ASM
2	104-5501	4	Hose ASM
3	104-5502	1	Hose ASM
4	104-5504	1	Hose ASM
5	104-5505	1	Hose ASM
6	104-5511	2	Hose ASM
6:1	237-42	1	O-Ring
7	104-5512	2	Hose ASM
7:1	237-42	1	O-Ring
8	104-5513	2	Hose ASM
8:1	237-42	1	O-Ring
9	105-9820	5	Motor-HYD
10	3256-24	10	Washer-Flat
11	3274-7	10	Screw-HSH
12	340-17	10	Fitting-HYD, 90 DEG
12:1	237-65	1	O-Ring
12:2	237-80	1	O-Ring
13	340-92	5	Fitting-HYD, Straight
13:1	237-78	1	O-Ring
13:2	237-21	1	O-Ring

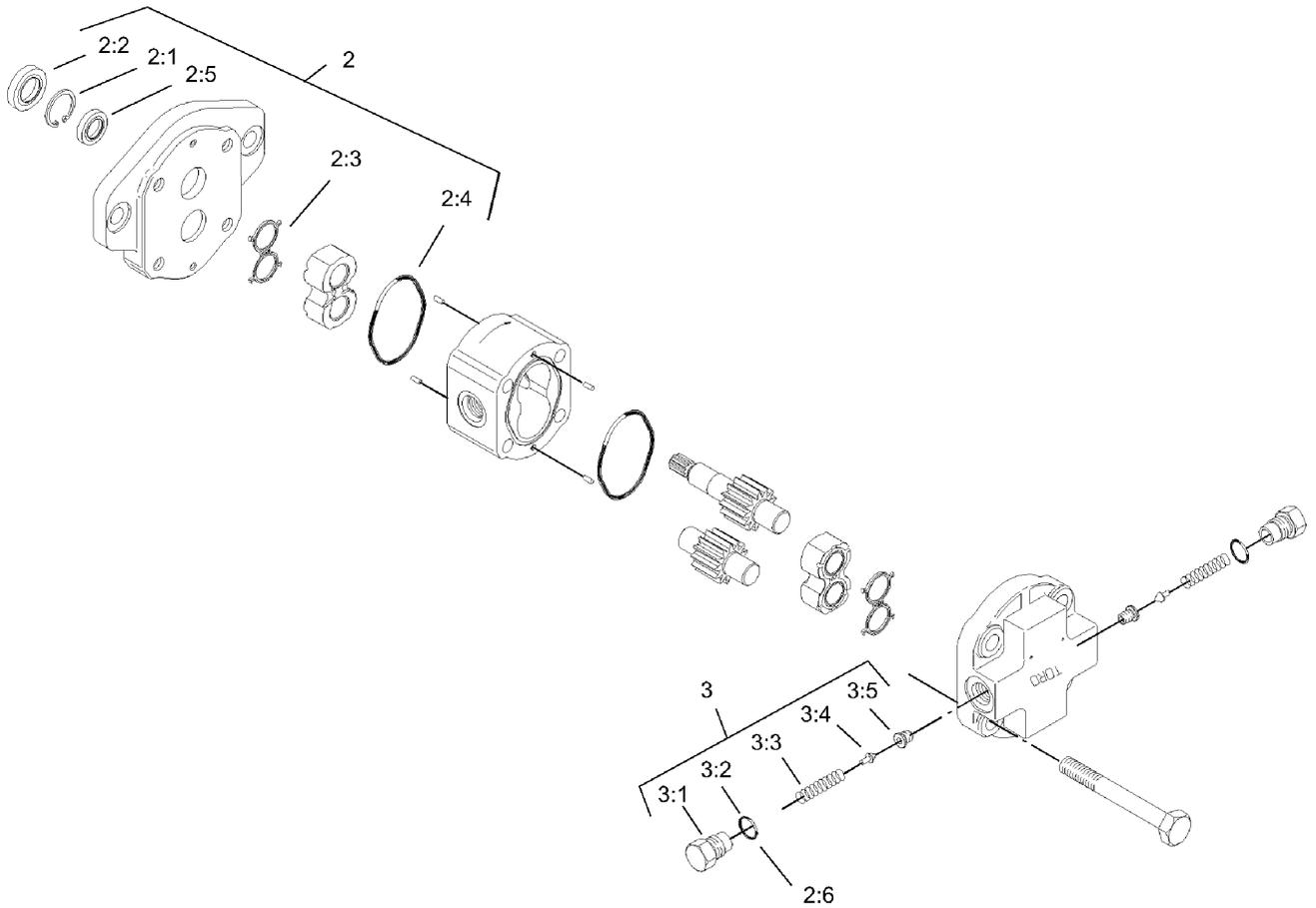

Hydraulic Motor Assembly No. 105-9820

Ref	Part No.	Qty.	Description
2	105-9191	1	Seal Kit
2:1		1	Ring-Retaining
2:2		1	Seal-Shaft
2:3		2	Seal ASM
2:4		2	Seal-Dust
2:5		1	Seal-Shaft
2:6		2	Seal-Dust
3	105-9192	1	Relief Valve Kit
3:1		1	Cap-Valve, Relief
3:2		1	Seal-Dust
3:3		1	Spring
3:4		1	Poppet
3:5		1	Seat-Valve, Relief

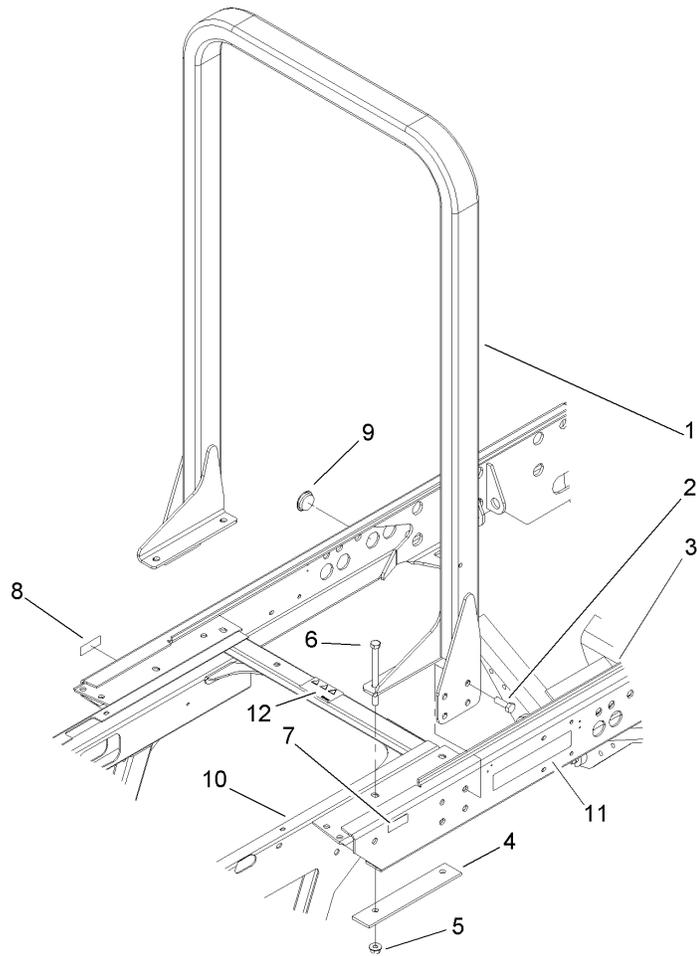

Roll-Over Protection System and Frame Assembly

Ref	Part No.	Qty.	Description				
1	104-5579-03	1	ROPS ASM				
2	3234-38	10	Screw-HHF				
3	104-5410-03	1	Frame-Rear				
4	104-5584-03	2	Plate-Reinforcement, ROPS				
5	32128-49	4	Nut-HHF				
6	325-20	4	Screw-HH				
7	93-6680	1	Decal-Diesel				
8	93-6686	1	Decal-Oil, HYD				
9	105-9194	4	Plug				
10	104-5469	1	Front Frame ASM				
11	72-3560	2	Decal				
12	106-6754	1	Decal-Danger				

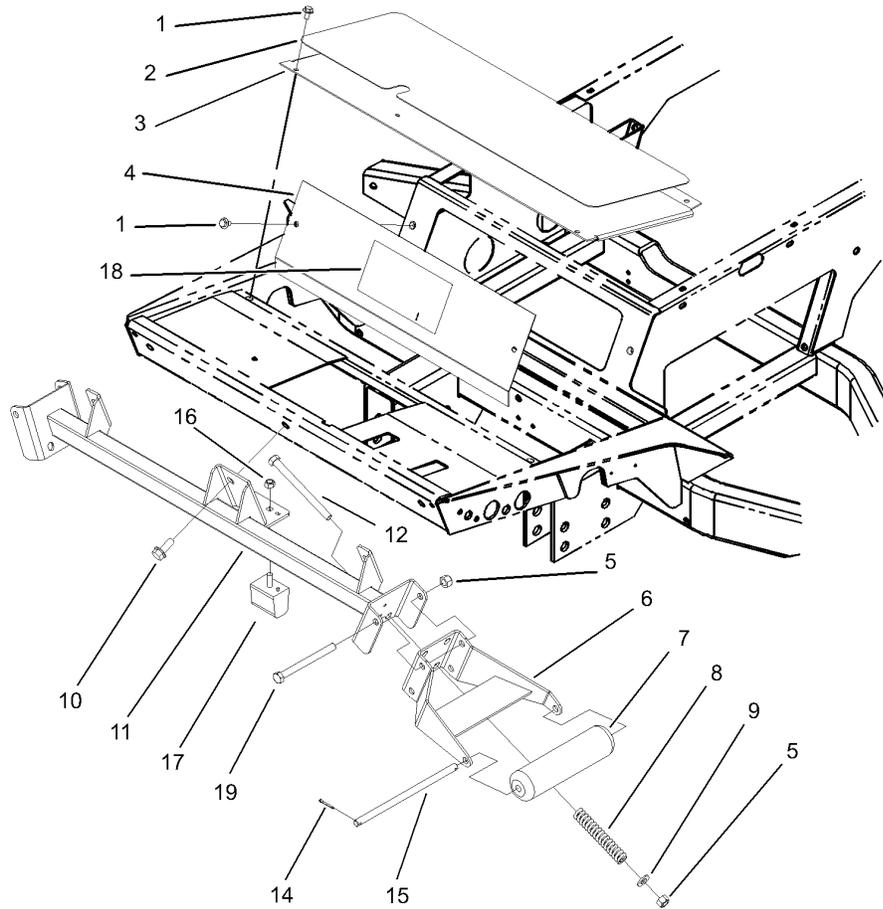

Roller Support and Access Panel Assembly

Ref	Part No.	Qty.	Description
1	3234-7	7	Screw-HHF
2	75-0630	1	Tread-Foot, Center
3	75-1410-01	1	Plate-Access, Floor
4	105-9243-01	1	Plate-Access
5	3296-23	4	Nut-Lock, NI
6	105-3996-01	2	Roller Support ASM
7	105-9816	2	Roller-Plastic
8	105-3970	2	Spring-Compression
9	3256-26	2	Washer-Flat
10	3234-38	3	Screw-HHF
11	104-5539-01	1	Roller Support ASM
12	325-22	2	Screw-HH
14	3272-11	4	Pin-Cotter
15	104-5545	2	Shaft-Roller
16	33025-00	1	Nut-Lock
17	87-3470	1	Bumper-Axle, Rear
18	105-3889	1	Decal-Danger
18	107-1983	1	Decal-Warning
19	325-20	2	Screw-HH

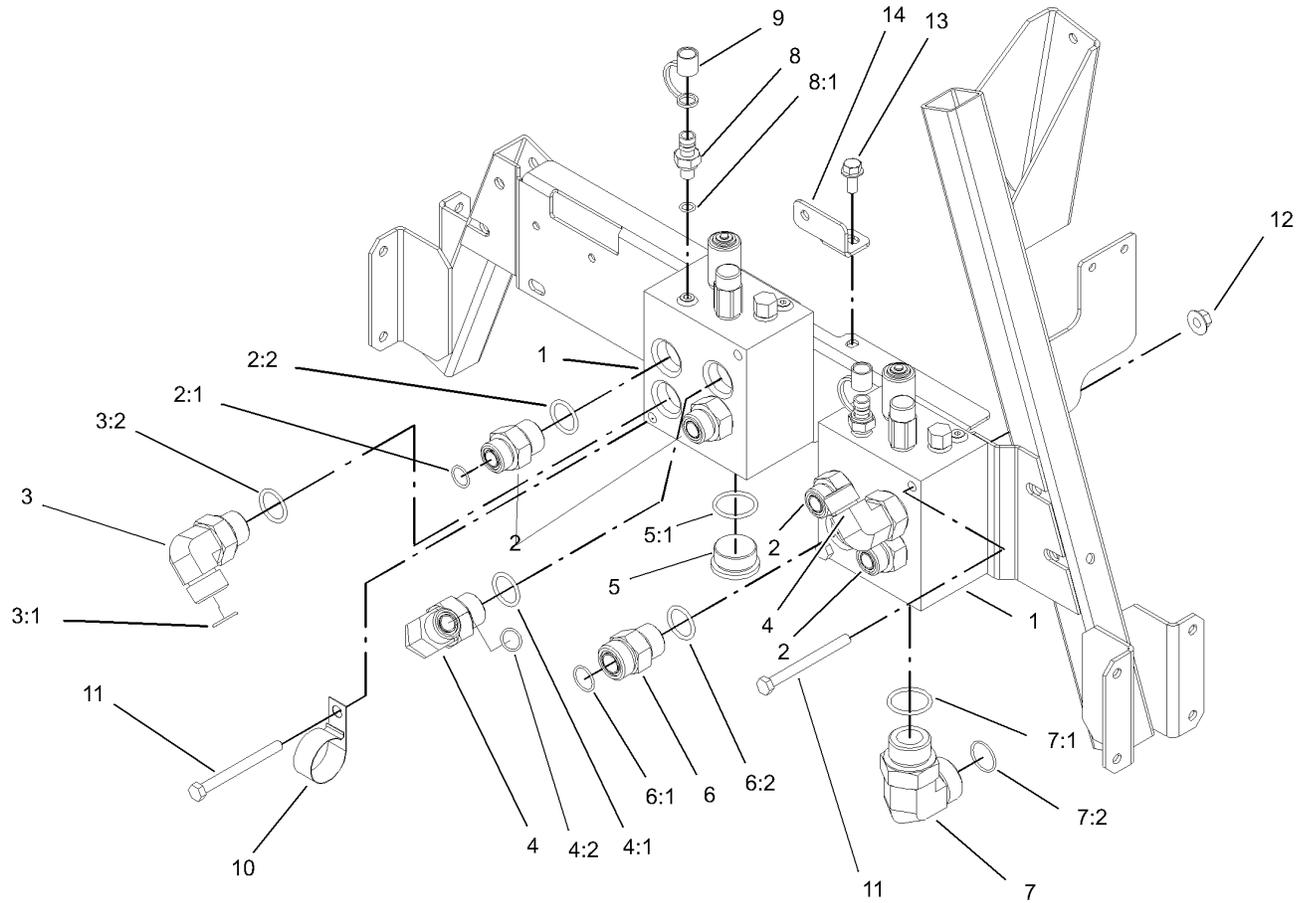

Manifold Assembly

Ref	Part No.	Qty.	Description
1	104-5475	2	Manifold ASM
2	340-8	4	Adapter
2:1	237-65	1	O-Ring
2:2	237-81	1	O-Ring
3	340-142	1	Fitting-HYD, 90 DEG
3:1	237-58	1	O-Ring
3:2	237-81	1	O-Ring
4	340-139	2	Fitting-HYD, 90 DEG
4:1	237-81	1	O-Ring
4:2	237-65	1	O-Ring
5	105-3921	1	Fitting-Plug
5:1	237-146	1	O-Ring
6	340-9	1	Fitting-Straight
6:1	237-58	1	O-Ring
6:2	237-81	1	O-Ring
7	340-129	1	Fitting-HYD, 90 DEG
7:1	237-146	1	O-Ring
7:2	340-65	1	O-Ring
8	354-77	2	Fitting-Quick
8:1	237-78	1	O-Ring
9	354-79	2	Cap-Dust
10	2412-150	1	Clip-J
11	322-22	4	Screw-HH
12	32128-44	5	Nut

Ref	Part No.	Qty.	Description
13	3234-5	1	Screw-HHF
14	104-5487	1	Bracket-L

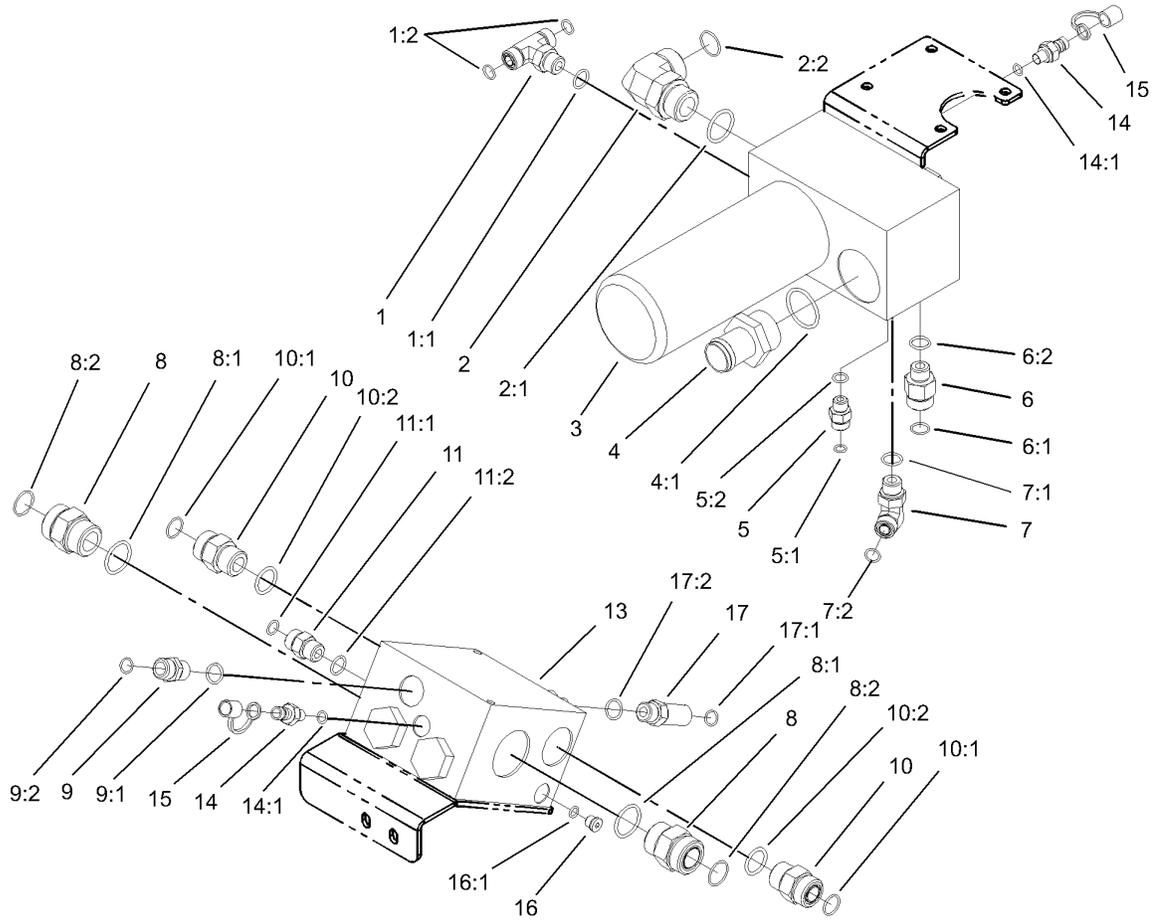

4 Wheel Drive Manifold and Filter Assembly

Ref	Part No.	Qty.	Description
1	340-157	1	Fitting-HYD, Tee
1:1	237-79	1	O-Ring
1:2	237-30	2	O-Ring
2	340-129	1	Fitting-HYD, 90 DEG
2:1	237-146	1	O-Ring
2:2	340-65	1	O-Ring
3	100-5558	1	Manifold-Filter
4	104-5480	1	Fitting-Hose, Straight
4:1	237-123	1	O-Ring
5	340-2	1	Fitting-HYD, Straight
5:1	237-22	1	O-Ring
5:2	237-42	1	O-Ring
6	340-155	1	Fitting-HYD, Straight
6:1	237-79	1	O-Ring
6:2	237-151	1	O-Ring
7	340-98	1	Fitting-HYD, 90 DEG
7:1	237-79	1	O-Ring
7:2	237-30	1	O-Ring
8	104-3797	2	Fitting-HYD, Straight
8:1	237-146	1	O-Ring
8:2	340-65	1	O-Ring
9	100-4890	1	Fitting-Check
9:1	237-79	1	O-Ring
9:2	237-30	1	O-Ring

Ref	Part No.	Qty.	Description
10	340-9	2	Fitting-Straight
10:1	237-58	1	O-Ring
10:2	237-81	1	O-Ring
11	340-4	1	Fitting-HYD, Straight
11:1	237-30	1	O-Ring
11:2	237-79	1	O-Ring
13	105-9875	1	4-Wheel Drive Manifold ASM
14	354-77	2	Fitting-Quick
14:1	237-78	1	O-Ring
15	354-79	2	Cap-Dust
16	353-990	1	Plug
16:1	237-78	1	O-Ring
17	94-2628	1	Adapter-HYD
17:1	237-79	1	O-Ring
17:2	237-30	1	O-Ring

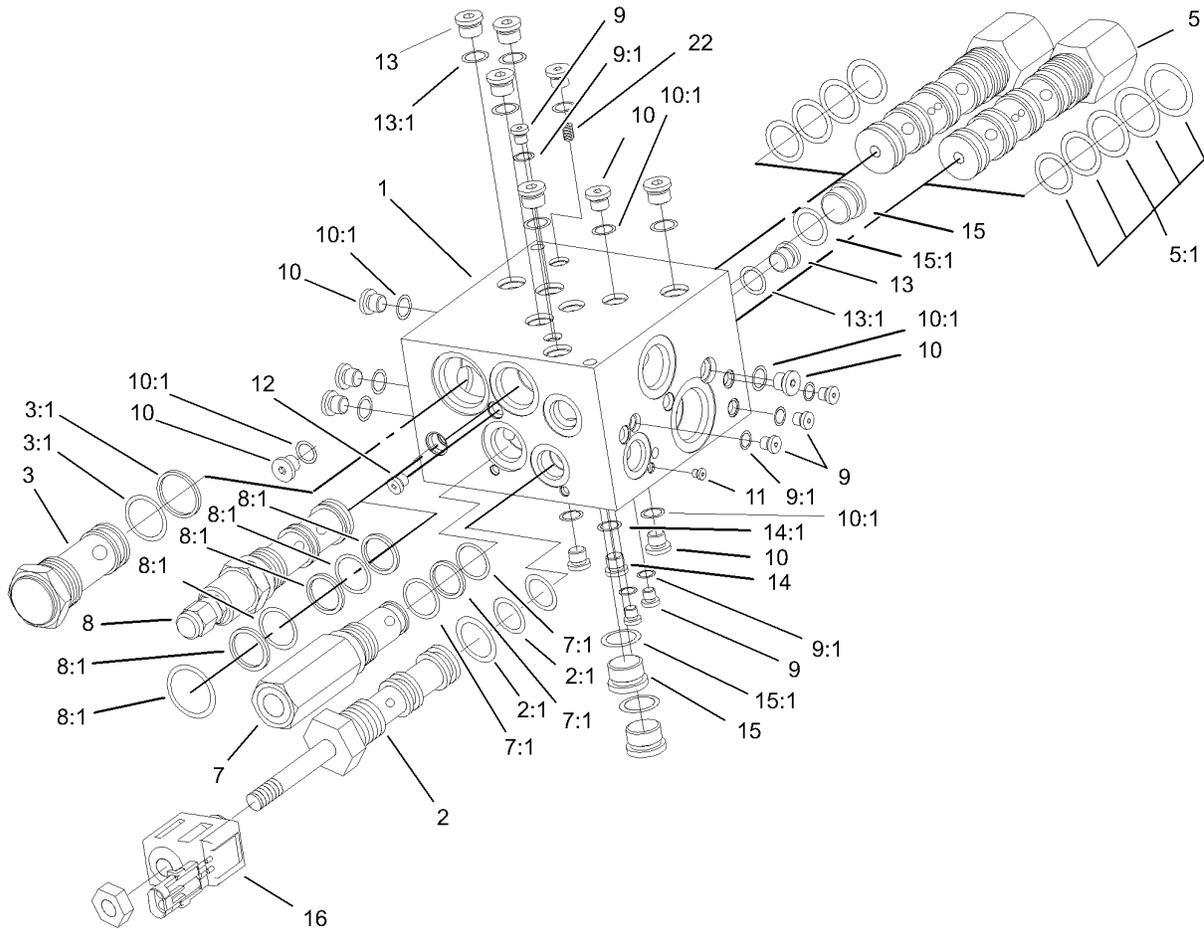

4 Wheel Drive Manifold Assembly No. 105-9875

Ref	Part No.	Qty.	Description
1		1	Manifold
2	104-8603	1	Valve-Solenoid
2:1	99-5505	1	Seal Kit
3	104-8604	1	Valve-Check
3:1	99-5506	1	Seal Kit
5	104-8605	2	Valve-Control
5:1	99-5507	1	Seal Kit
7	105-9847	1	Valve-Relief
7:1	99-5503	1	Seal Kit
8	105-9848	1	Valve-Reducing
8:1	104-4266	1	Seal Kit
9	353-991	2	Plug-Hex, Hollow
9:1	237-156	1	O-Ring
10	354-137	3	Plug
10:1	237-86	1	O-Ring
11		10	Plug-Expander
12		10	Plug-Expander
13	353-989	6	Plug-Hex, Hollow
13:1	237-42	1	O-Ring
14	353-990	1	Plug
14:1	237-78	1	O-Ring
15	354-70	3	Plug-Hex, Hollow
15:1	237-80	1	O-Ring
16	104-4264	1	Coil-Solenoid

Ref	Part No.	Qty.	Description
22	106-6766	1	Plug-Orifice

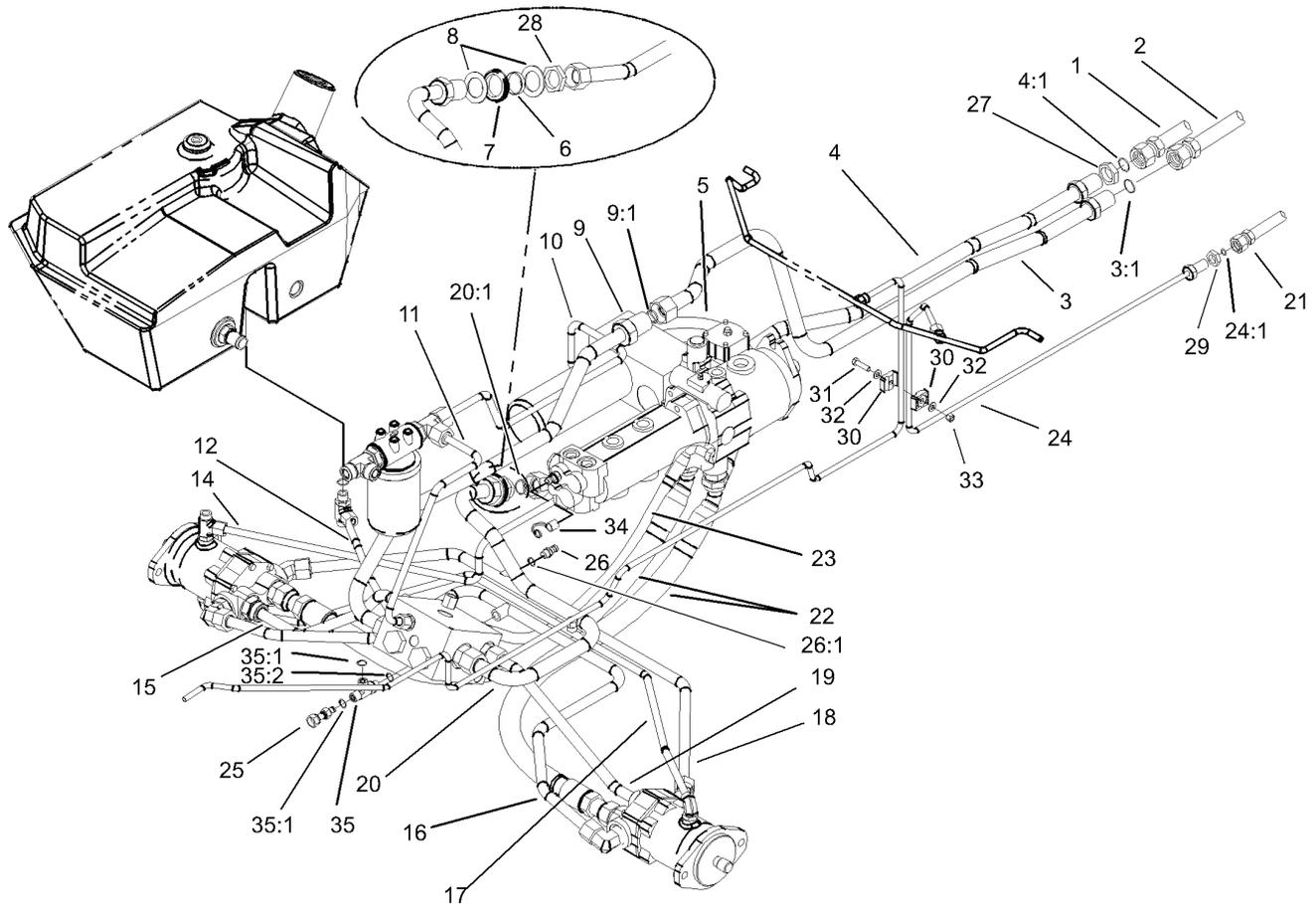

Traction Hydraulic Line Assembly

Ref	Part No.	Qty.	Description
1	92-7536	1	Hose ASM
2	105-9818	1	Hose ASM
3	104-5476	1	Tube ASM
3:1	340-65	1	O-Ring
4	104-5478	1	Tube ASM
4:1	340-65	1	O-Ring
5	105-3864	1	Hose ASM
6	69-8950	2	Spacer
7	240-2	2	Grommet-Rubber
8	69-8920	4	Washer
9	104-5472	1	Tube ASM
9:1	340-65	1	O-Ring
10	105-3861	1	Tube ASM
11	105-3915	1	Tube ASM
12	104-5489	1	Tube ASM
14	105-3866	1	Tube ASM
15	104-5470	1	Tube ASM
16	105-3984	1	Tube ASM
17	105-3865	1	Tube ASM
18	104-5462	1	Tube ASM
19	104-5468	1	Tube ASM
20	104-5473	1	Tube ASM
20:1	340-65	1	O-Ring
21	92-7534	1	Hose ASM

Ref	Part No.	Qty.	Description
22	104-5464	2	Hose ASM
23	105-3985	1	Hose ASM
24	105-9863	1	Tube-HYD
24:1	237-22	1	O-Ring
25	86-5480	1	Nipple-Test
26	59-7410	1	Tip-Nipple, Diagnostic
26:1	237-42	1	O-Ring
27	340-126	2	Nut-Bulkhead
28	340-128	2	Nut-Bulkhead
29	340-70	1	Nut-Lock
30	56-7973	2	Clamp-Tube
31	322-6	1	Screw-HH
32	3256-23	2	Washer-Flat
33	3296-29	1	Nut-Lock, NI
34	354-79	2	Cap-Dust
35	340-86	1	Fitting-Tee
35:1	237-22	2	O-Ring
35:2	237-42	1	O-Ring

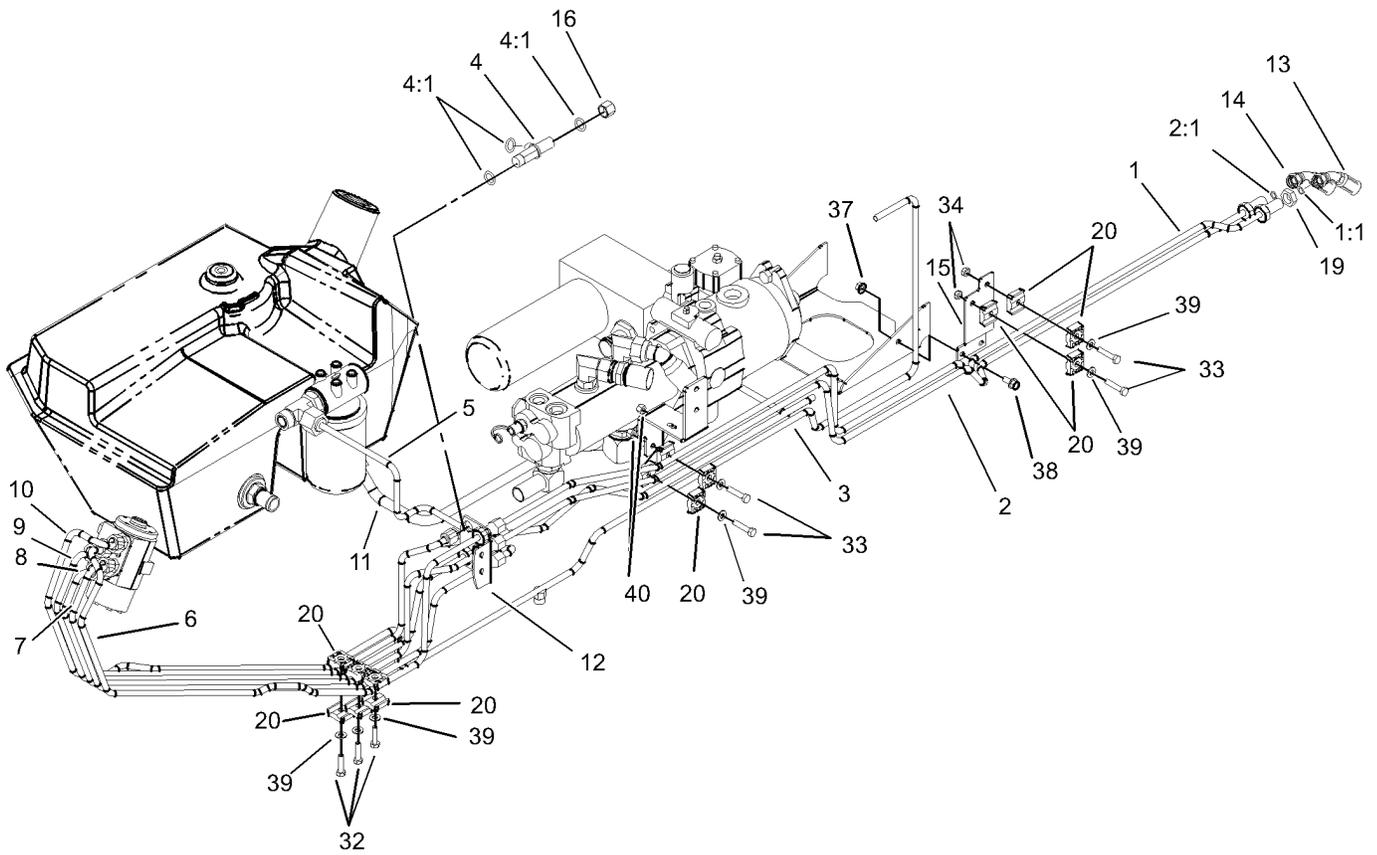

Steering Hydraulic Line Assembly

Ref	Part No.	Qty.	Description
1	105-3871	1	Tube ASM
1:1	237-22	1	O-Ring
2	105-3870	1	Tube ASM
2:1	237-22	1	O-Ring
3	105-3887	1	Tube ASM
4	340-68	1	Fitting-Tee, Bulkhead
4:1	237-22	3	O-Ring
5	105-3886	1	Tube ASM
6	94-3060	1	HYD Tube ASM
●6:1	237-22	1	O-Ring
7	94-3071	1	HYD Tube ASM
●7:1	237-22	1	O-Ring
8	94-3059	1	HYD Tube ASM
●8:1	237-22	1	O-Ring
9	94-3061	1	HYD Tube ASM
●9:1	237-22	1	O-Ring
10	94-3062	1	HYD Tube ASM
11	104-5485	1	Tube ASM
12	92-7606-03	1	Bracket-Bulkhead
13	105-9817	1	Hose ASM
14	92-7539	1	Hose ASM
15	105-3873-03	1	Bracket-Mount, Clamp
16	340-117	1	Cap
19	340-70	7	Nut-Lock

Ref	Part No.	Qty.	Description
20	56-7973	14	Clamp-Tube
32	322-6	3	Screw-HH
33	322-7	4	Screw-HH
34	3296-29	2	Nut-Lock, NI
37	32128-20	2	Nut-HF
38	3234-5	2	Screw-HHF
39	3256-23	7	Washer-Flat
40	3296-29	4	Nut-Lock, NI

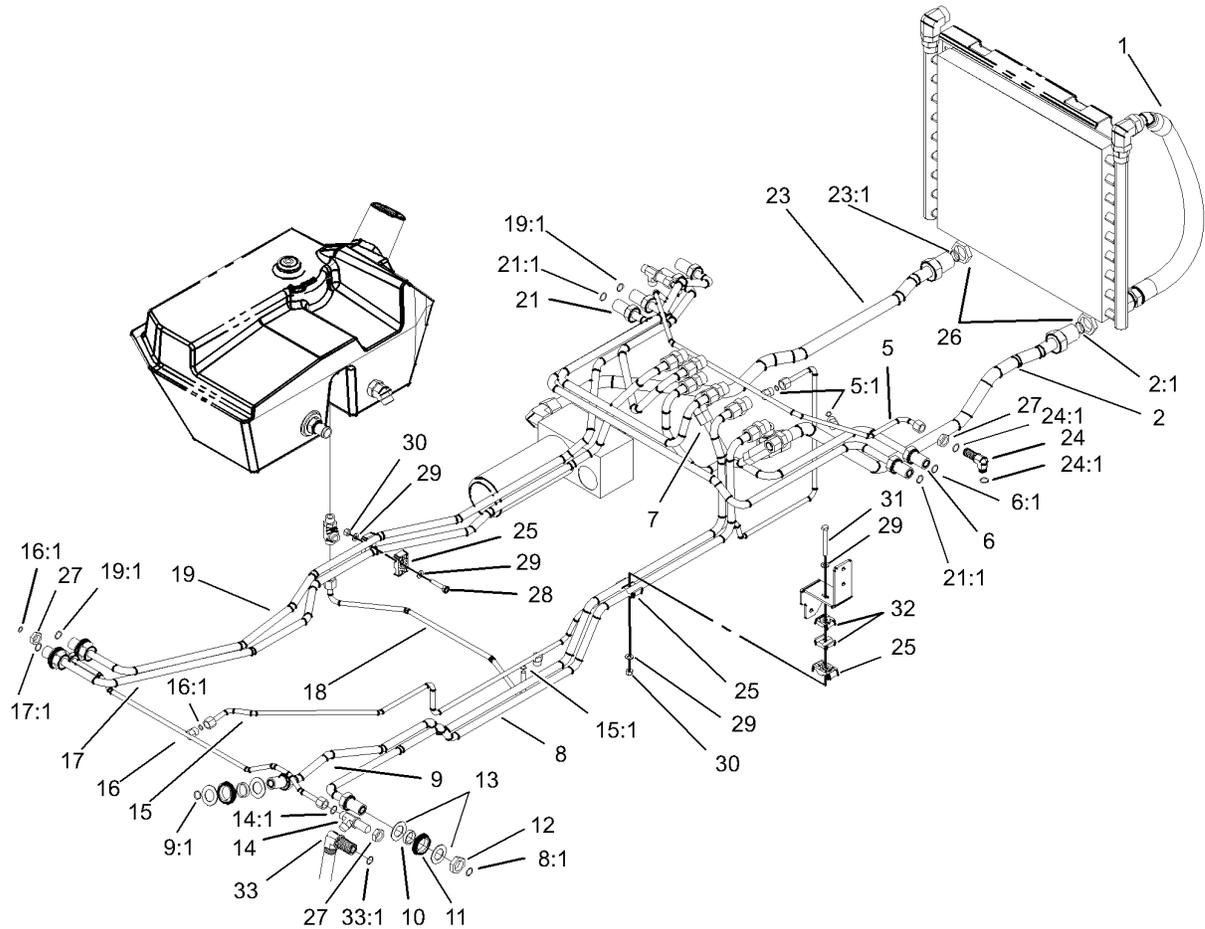

Mow Block Hydraulic Line Assembly

Ref	Part No.	Qty.	Description
1	104-5483	2	Hose ASM
2	104-5488	1	Tube ASM
2:1	340-65	1	O-Ring
5	105-9862	1	Tube ASM
5:1	237-22	2	O-Ring
6	105-3895	1	Tube ASM
6:1	237-65	1	O-Ring
7	105-3885	1	Tube ASM
8	105-3893	1	Tube ASM
8:1	237-65	1	O-Ring
9	105-3894	1	Tube ASM
9:1	237-65	1	O-Ring
10	69-9000	9	Spacer
11	240-3	9	Grommet-Rubber
12	340-74	9	Locknut-Bulkhead
13	69-9010	18	Washer
14	340-68	1	Fitting-Tee, Bulkhead
14:1	237-22	3	O-Ring
15	105-3914	1	Tube ASM
15:1	237-22	1	O-Ring
16	105-3913	1	Tube ASM
16:1	237-22	2	O-Ring
17	105-3902	1	Tube ASM
17:1	237-65	1	O-Ring

Ref	Part No.	Qty.	Description
18	105-3911	1	Tube ASM
19	105-3901	1	Tube ASM
19:1	237-65	2	O-Ring
21	105-3900	1	Tube ASM
21:1	237-65	2	O-Ring
23	104-5481	1	Tube ASM
23:1	340-65	1	O-Ring
24	340-154	2	Union-Bulkhead
24:1	237-22	2	O-Ring
25	56-7971	4	Clamp-Tube
26	340-128	2	Nut-Bulkhead
27	340-70	4	Nut-Lock
28	322-8	1	Screw-HH
29	3256-23	4	Washer-Flat
30	3296-29	2	Nut-Lock, NI
31	322-13	1	Screw-HH
32	56-7973	2	Clamp-Tube
33	340-72	1	Fitting-Bulkhead, 90 DEG
33:1	237-65	2	O-Ring

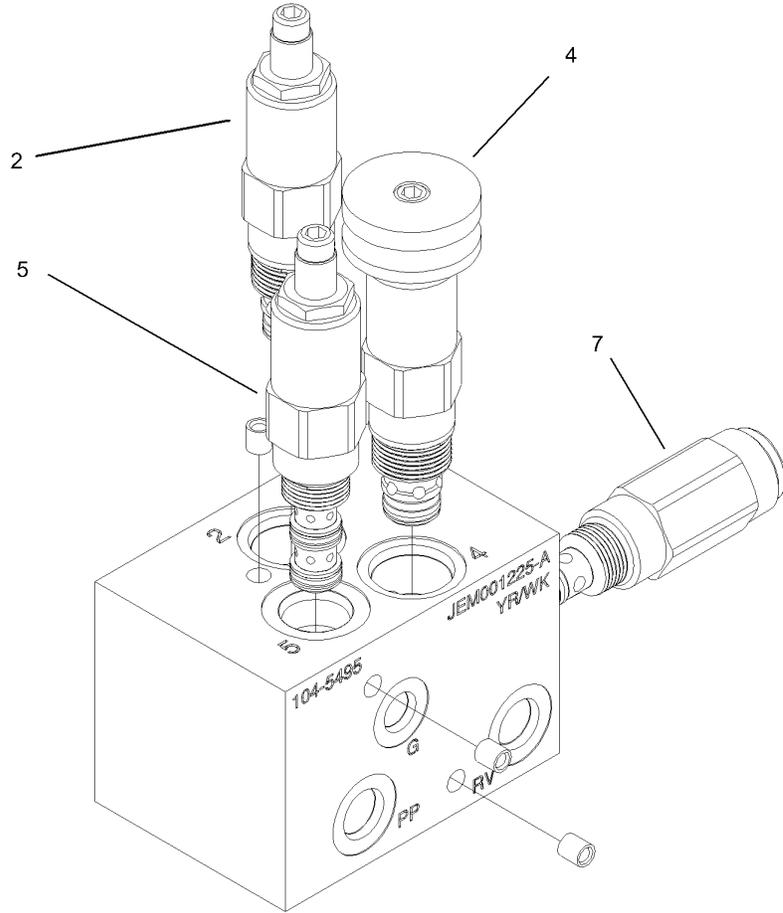

Manifold Assembly No. 104-5495

Ref	Part No.	Qty.	Description
2	105-9161	1	Relief-Operated, Pilot
●2:1	105-9151	1	Seal Kit
4	105-9162	1	Relief-Operated, Pilot
●4:1	105-9151	1	Seal Kit
5	105-9163	1	Valve-Pilot Sequence, EXT
●5:1	105-9164	1	Seal Kit
7	105-9844	1	Valve-Relief
●7:2	105-9156	1	Seal Kit

--	--	--	--

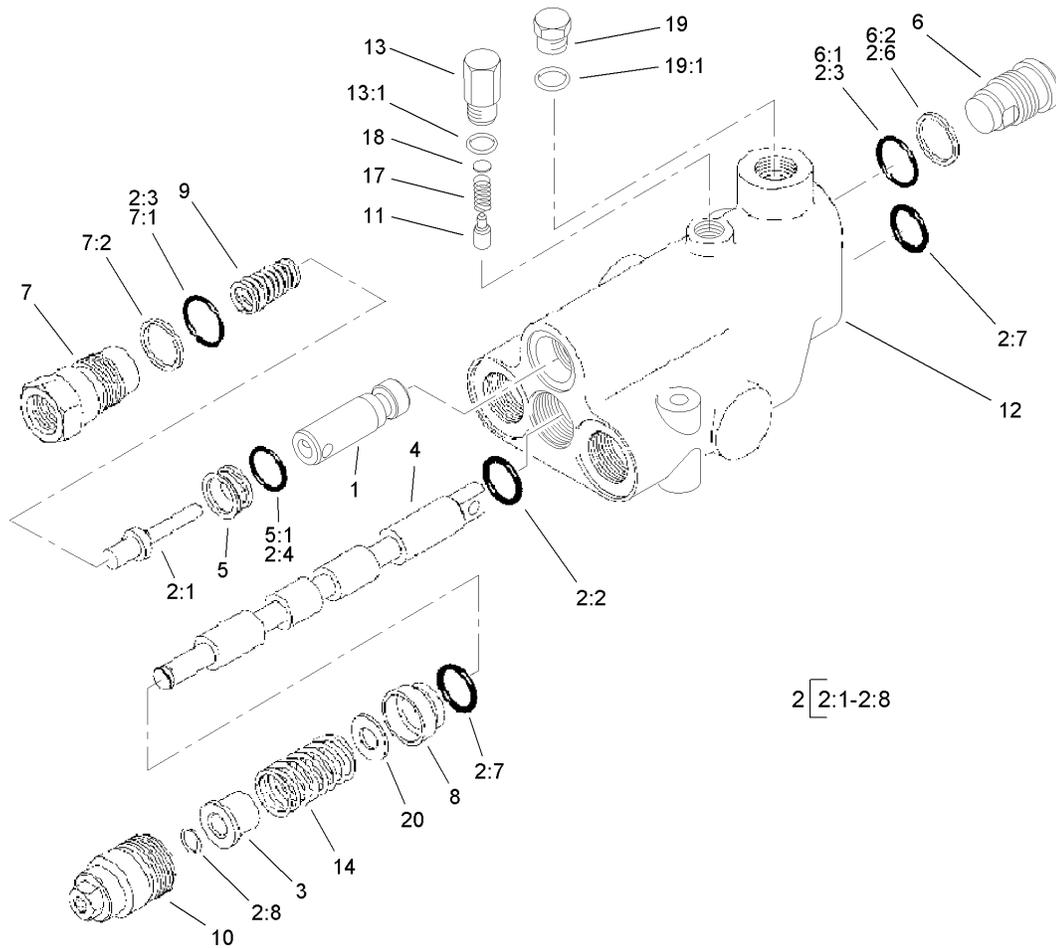

Single Spool Valve Assembly No. 104-5494

Ref	Part No.	Qty.	Description
1	84-6420	1	Plunger
2	99-3589	1	Seal Kit
2:1	58-6290	2	Poppet
2:2	58-6320	1	Wiper
2:3	60-5720	2	O-Ring
2:4	58-6340	2	O-Ring
2:5	93-6314	1	O-Ring
2:6	58-6370	2	Washer
2:7	58-6450	2	O-Ring
2:8	58-6460	1	Ring-Retaining
3	58-6310	1	Spacer
4		1	Spool
5	58-6330	1	Seat
5:1	58-6340	1	O-Ring
6	58-6350	1	Plug
6:1	60-5720	1	O-Ring
6:2	58-6370	1	Washer
7	69-1800	1	Plug ASM
7:1	60-5720	1	O-Ring
7:2	58-6370	1	Washer
8	58-6400	1	Bushing
9	69-1810	1	Spring
10	58-6420	1	Cap
11	58-6770	1	Plunger

Ref	Part No.	Qty.	Description
12		1	Body
13	58-6780	1	Plug
13:1	58-6790	1	O-Ring
14	58-6730	1	Spring
17	58-6760	1	Spring
18	60-6450	1	Disc
19	353-508	1	Plug
19:1	237-42	1	O-Ring
20	65-2770	1	Washer

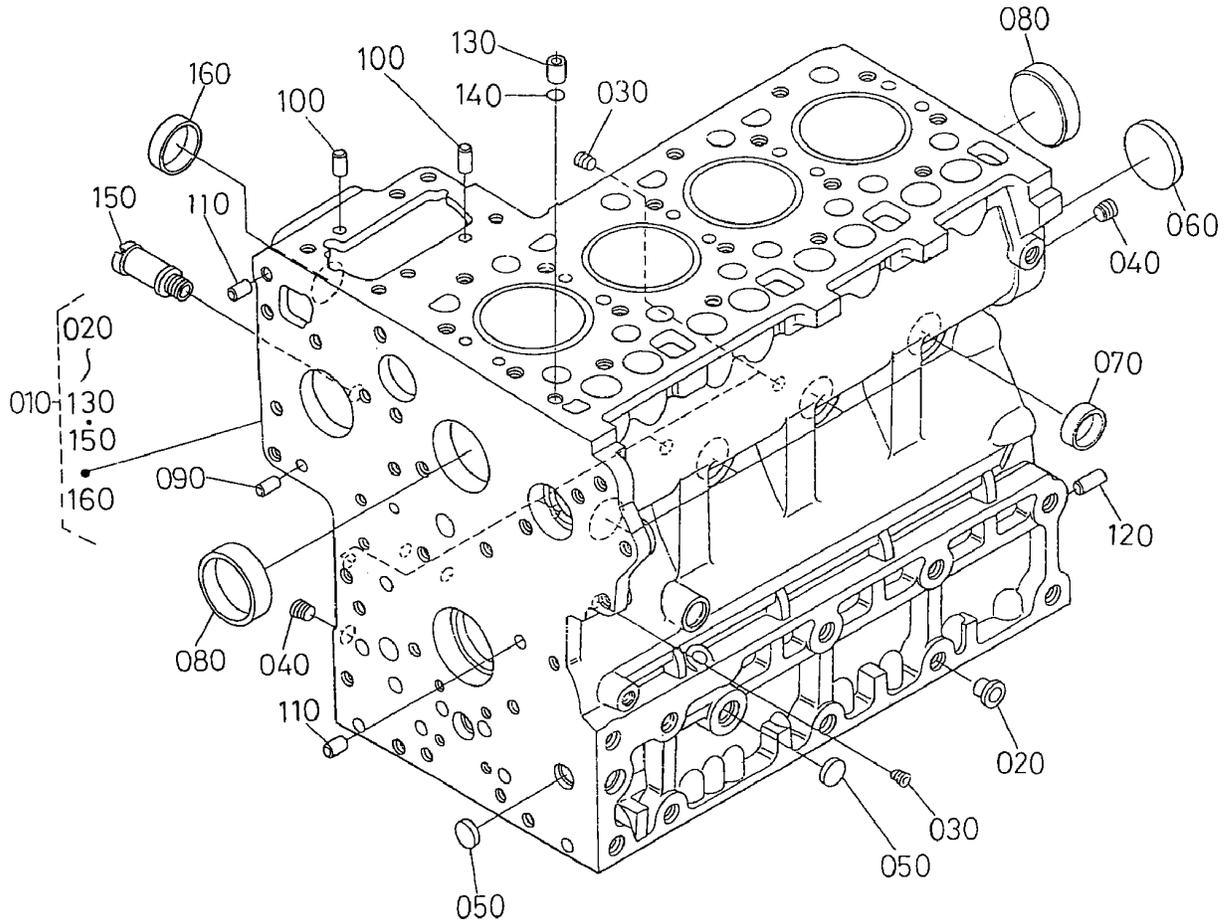

Crankcase Assembly

Ref	Part No.	Qty.	Description
10	100-9150	1	Crankcase
20	98-7486	2	Plug
30	98-7487	6	Plug
40	107-0107	2	Plug
50	98-7489	3	Plug
60	98-7490	1	Plug
70	98-7500	6	Cap-Sealing
80	98-7501	2	Cap-Sealing
90	98-7502	2	Pin-Straight
100	98-7503	2	Pin-Straight
110	98-7504	2	Pin-Straight
120	98-7505	1	Pin-Straight
130	98-7506	1	Pin-Pipe
140	98-7509	1	O-Ring
150	100-9153	1	Pipe-Return, Water
160	105-2883	1	Cap-Sealing

--	--	--	--

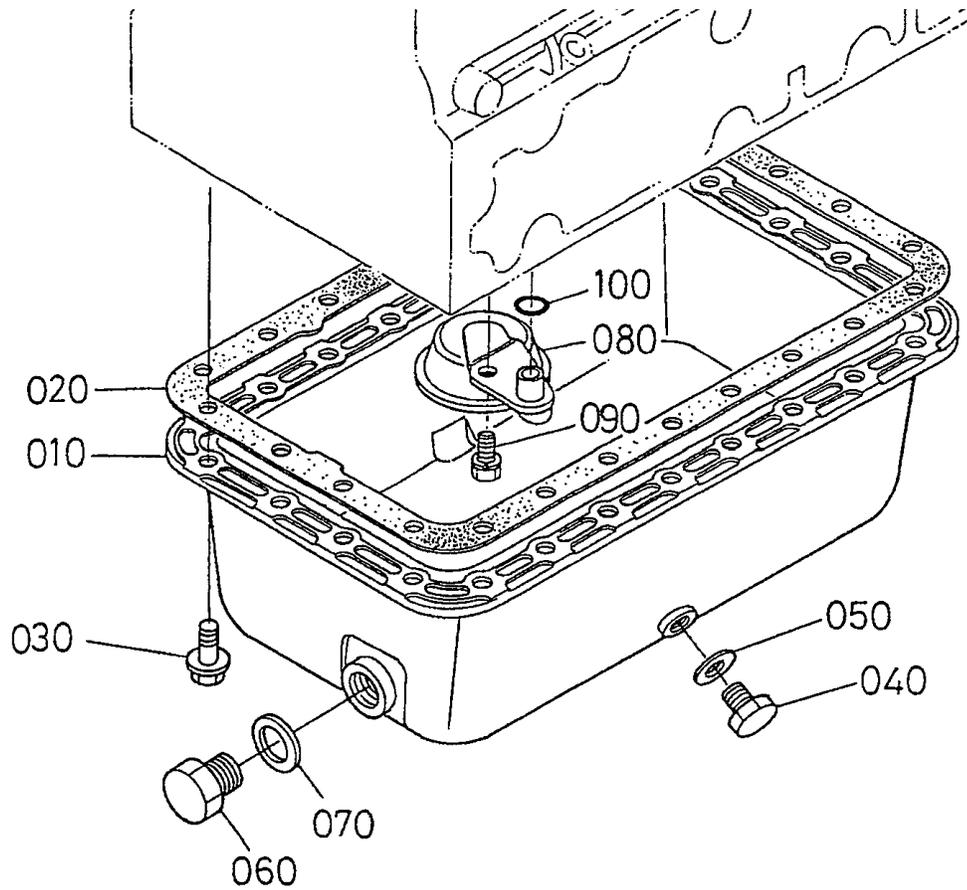

Oil Pan Assembly

Ref	Part No.	Qty.	Description				
10	98-7520	1	Pan-Oil				
20	98-7521	1	Gasket				
30	98-7522	24	Bolt-Flange				
40	98-9386	1	Plug				
50	98-7524	1	Gasket				
60	98-7529	1	Plug-Drain				
70	98-7528	1	O-Ring				
80	98-7525	1	Filter-Oil				
90	100-9192	1	*obs* Bolt				
100	107-0101	1	O-Ring				

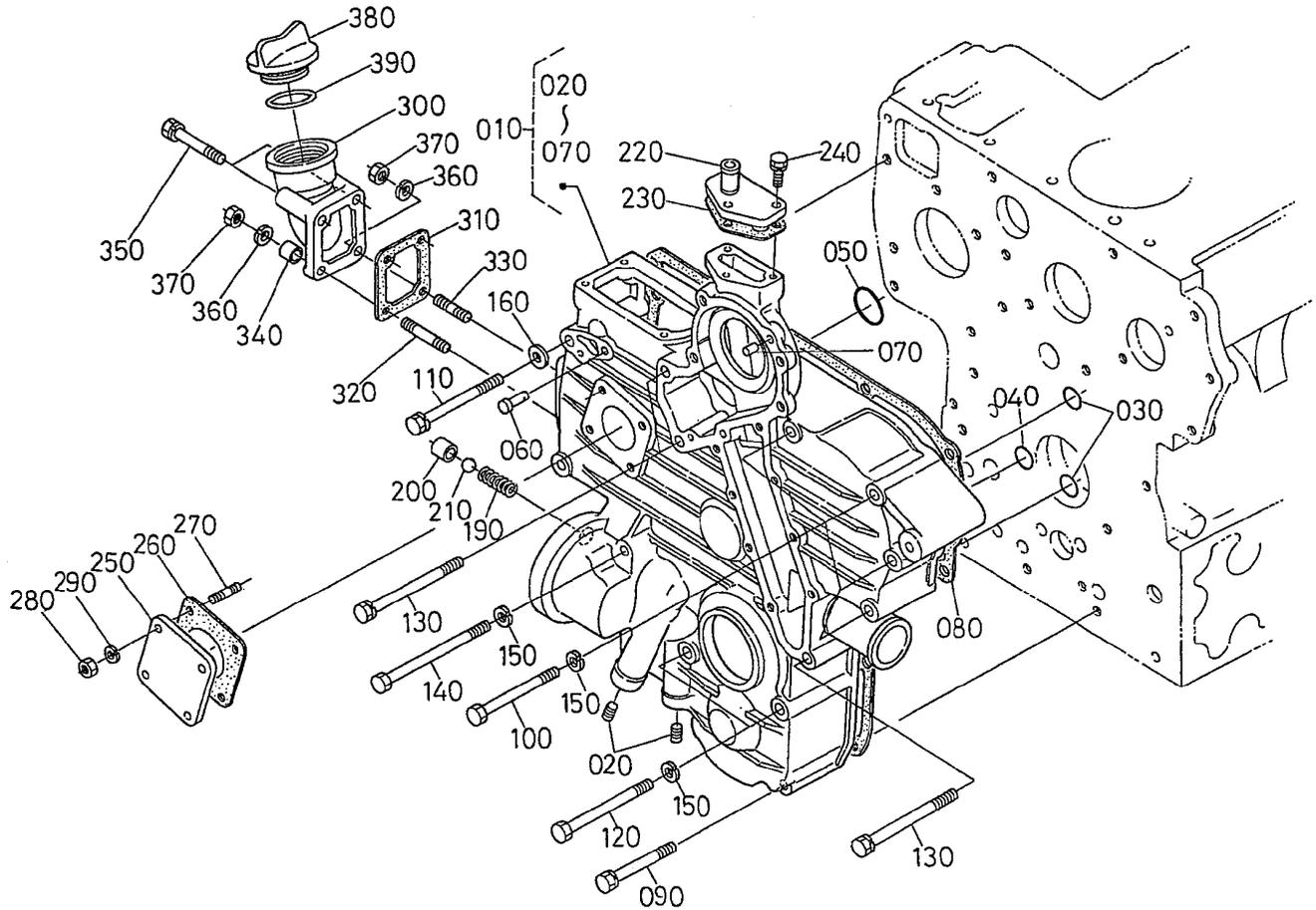

Gear Case Assembly

Ref	Part No.	Qty.	Description
10	100-9161	1	Gearcase ASM
20	107-0108	2	Plug
30	107-0104	2	O-Ring
40	107-0105	1	O-Ring
50	107-0106	1	O-Ring
60	98-7550	1	Pin-Spring, Start
70	98-7504	2	Pin-Straight
80	98-7552	1	Packing-Case, Gear
90	98-7553	2	Bolt
100	99-8336	5	Bolt
110	98-7555	1	Bolt
120	98-7556	2	Bolt
130	98-7557	3	Bolt
140	98-7558	2	Bolt
150	105-2893	9	Washer-Spring
160	98-7536	1	Washer-Plain
190	98-7563	1	Spring
200	98-7564	1	Seat-Valve
210	98-7565	1	Ball
220	98-7566	1	Flange-Return, Water
230	98-7567	1	Gasket
240	98-7568	3	Bolt
250	98-7569	1	Cover
260	98-7570	1	Gasket-Meter, Hour

Ref	Part No.	Qty.	Description
270	98-7571	4	Stud
280	98-7572	4	Nut
290	98-7699	4	Washer-Spring
300	100-9162	1	Flange-Filter, Oil
310	100-9163	1	Gasket
320	98-7571	1	Stud
330	100-9164	1	Stud
340	100-9165	1	Collar
350	98-7496	2	Bolt
360	98-7699	2	Washer-Spring
370	98-7572	2	Nut
380	98-7429	1	Plug-Filter, Oil
390	107-0102	1	O-Ring

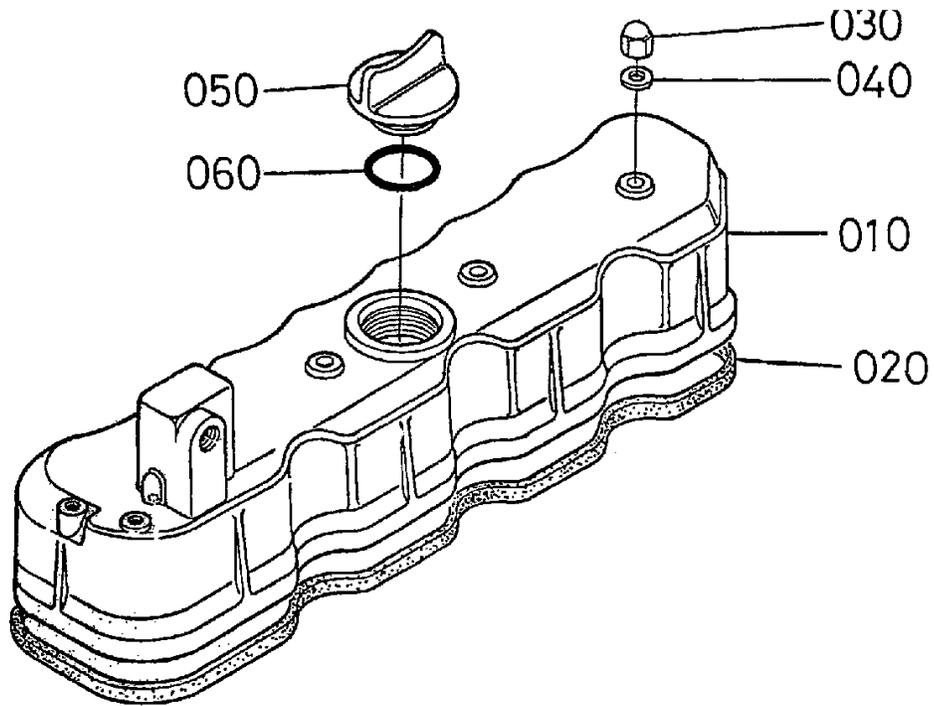

Head Cover Assembly

Ref	Part No.	Qty.	Description
10	98-7425	1	Cover-Head, Cylinder
20	98-7426	1	Gasket-Cover, Head
30	98-7427	4	Nut-Cap
40	98-7428	4	Gasket
50	98-7429	1	Plug-Filter, Oil
60	107-0102	1	O-Ring

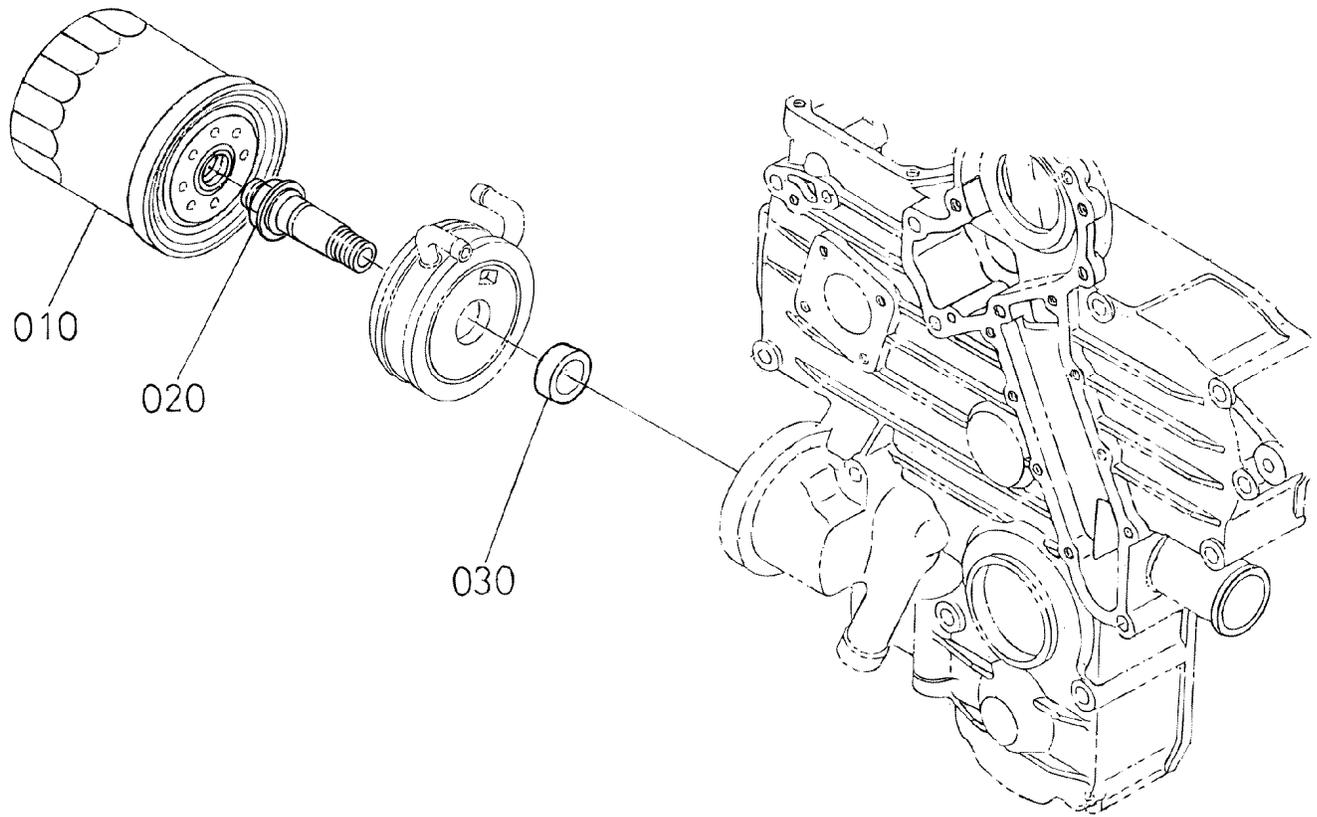

Oil Filter Assembly

Ref	Part No.	Qty.	Description
10	104-5169	1	Filter-Oil
20	100-9166	1	Connector
30	100-9167	1	Collar

--	--	--	--

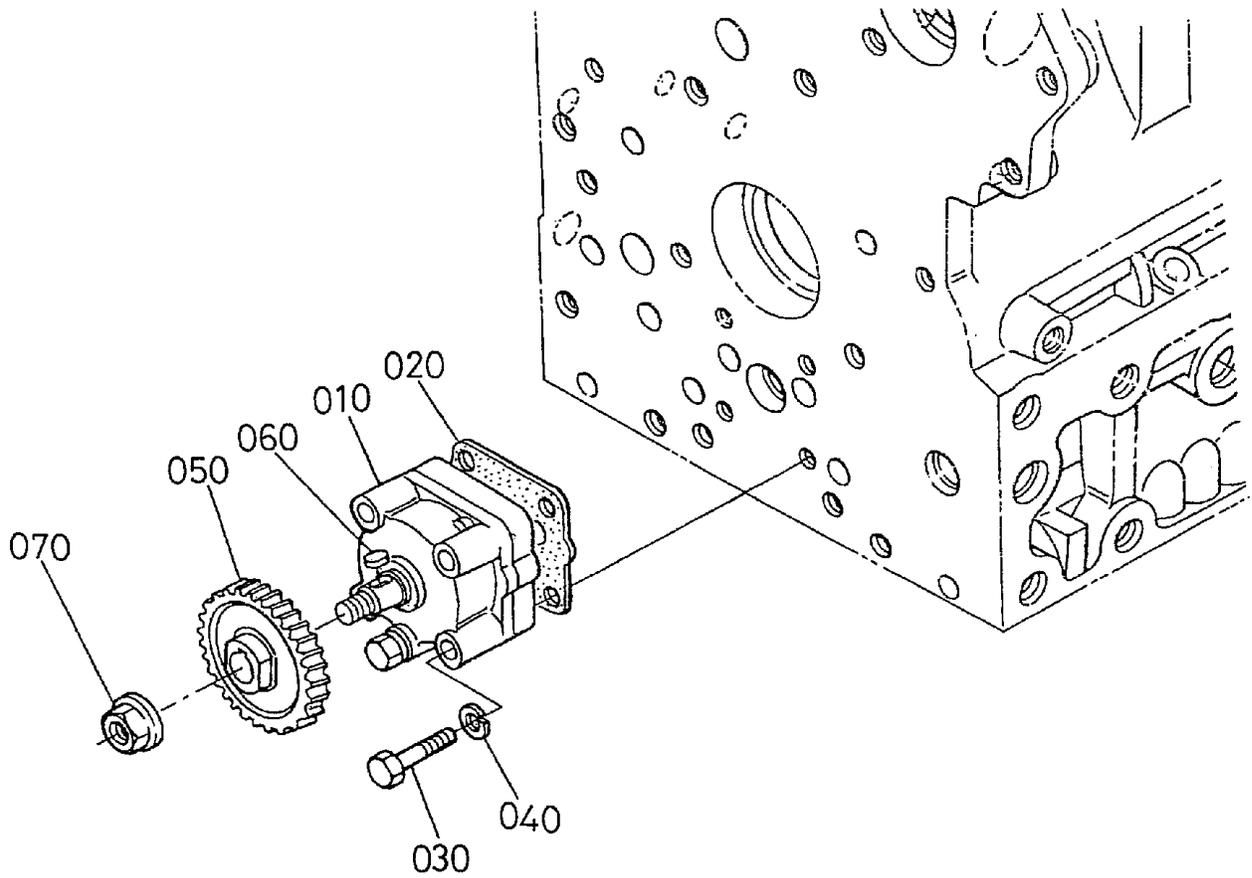

Oil Pump Assembly

Ref	Part No.	Qty.	Description
10	100-9170	1	Oil Pump ASM
20	98-7513	1	Gasket-Pump, Oil
30	98-7514	4	Bolt
40	98-7699	4	Washer-Spring
50	98-7516	1	Gear-Drive, Oil Pump
60	98-7517	1	Key-Feather
70	98-7518	1	Nut-Flange

--	--	--	--

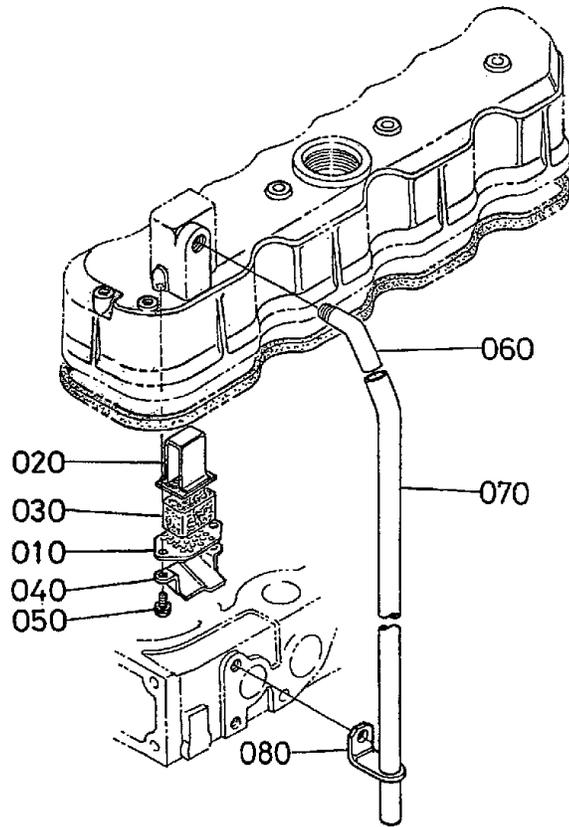

Breather Assembly

Ref	Part No.	Qty.	Description				
10	98-7417	1	Plate-Element				
20	98-7418	1	Plate-Element				
30	98-7419	1	Element-Breather				
40	98-7420	1	Shield-Breather, Oil				
50	98-7421	2	Screw W/Washer				
60	98-7422	1	Joint-Pipe, Breather				
70	98-7423	1	Pipe-Breather				
80	98-7424	1	Clamp-Pipe				

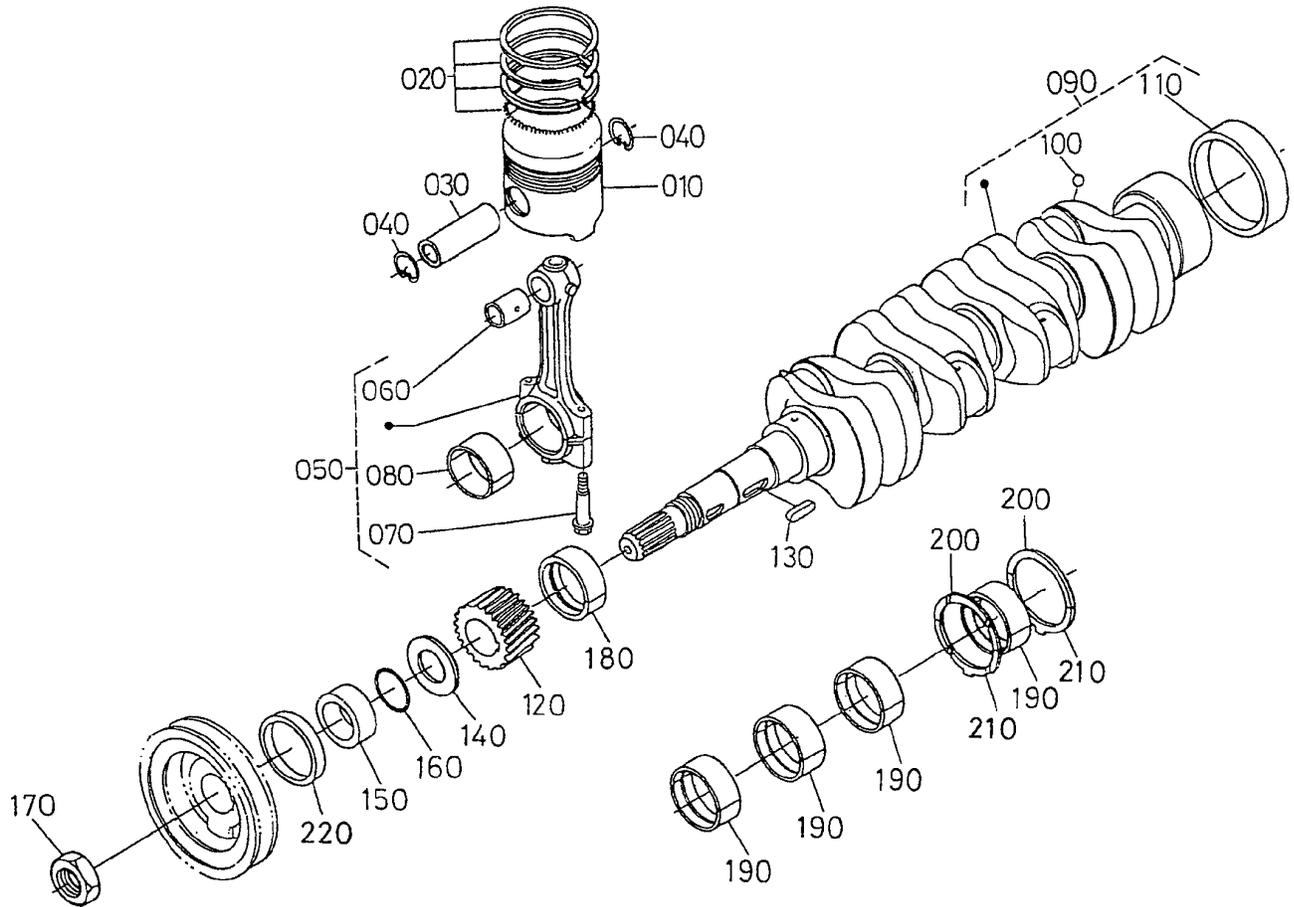

Piston and Crankshaft Assembly

Ref	Part No.	Qty.	Description
10	99-5435	1	Piston (.50Mm)
10	100-9181	4	Piston-STD
20	100-9182	4	Piston Ring ASM (STD)
20	99-5436	1	Piston Ring ASM (0.50Mm)
30	98-7464	4	Pin-Piston
40	98-7465	8	Clip-Pin, Piston
50	98-7466	4	Connecting Rod ASM
60	98-7467	4	Bushing-Pin, Piston
70	98-7468	8	Bolt-Rod, Connecting
80	98-7470	4	Metal-Crankpin (-0.20Mm)
80	98-7471	4	Metal-Crankpin (-0.40Mm)
80	98-7469	4	Metal-Crankpin (STD)
90	98-7472	1	Crankshaft-Complete
100	98-7473	4	Ball
110	98-7474	1	Sleeve-Crankshaft
120	98-7475	1	Gear-Crankshaft
130	98-7451	1	Key-Feather
140	98-7476	1	Slinger-Oil
150	98-7477	1	Collar-Crankshaft
160	98-7478	1	O-Ring
170	98-7479	1	Nut-Crankshaft
180	98-7481	1	Metal-Crankshaft (STD)
180	98-7482	1	Metal-Crankshaft (-0.20Mm)
180	98-7483	1	Metal-Crankshaft (-0.40Mm)

Ref	Part No.	Qty.	Description
190	98-7484	4	Metal-Crankshaft (STD)
190	99-6862	4	Metal-Crankshaft (-0.20Mm)
190	99-6863	4	Metal-Crankshaft (-0.40Mm)
200	98-9413	2	Bearing-Thrust (STD)
200	98-9414	2	Bearing-Thrust (0.2Mm)
200	98-9415	2	Bearing-Thrust (0.4Mm)
210	98-9688	2	Bearing-Thrust (STD)
210	98-9689	2	Bearing-Thrust (0.2Mm)
210	98-9690	2	Bearing-Thrust (0.4Mm)
220	98-7480	1	Seal-Oil

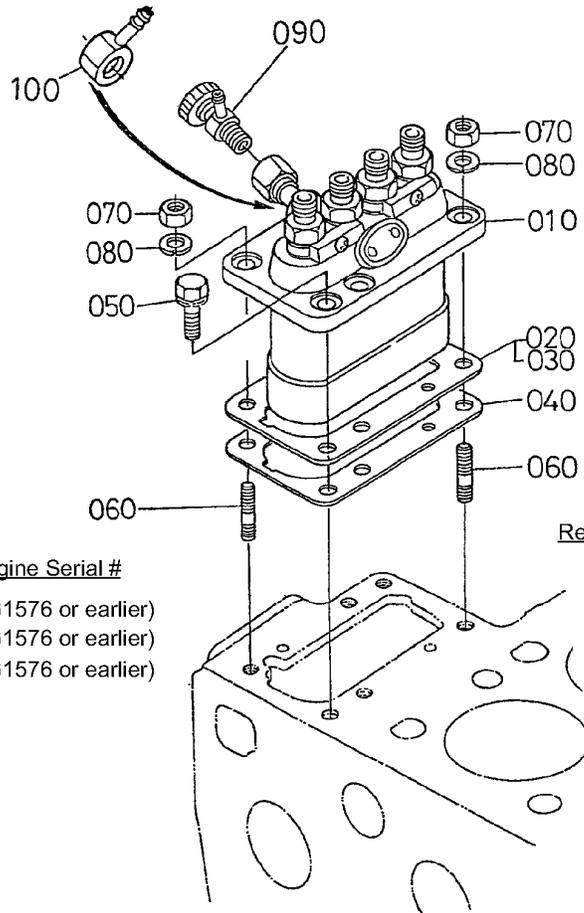

Ref. No.	Part No.	Engine Serial #
020	98-7607	(2G1576 or earlier)
030	98-7608	(2G1576 or earlier)
040	98-7609	(2G1576 or earlier)

Ref. No.	Part No.	Engine Serial #
020	107-0146	(2J0001 or newer)
030	107-0147	(2J0001 or newer)
040	107-0148	(2J0001 or newer)

Injection Pump Assembly

Ref	Part No.	Qty.	Description
10	100-9201	1	Injection Pump ASM
20	107-0146	1	Shim
20	98-7607	1	Shim
30	107-0147	1	Shim
30	98-7608	1	Shim
40	107-0148	1	Shim
40	98-7609	1	Shim-Pump, Injection
50	100-2562	4	Bolt
60	100-1558	2	Stud-Manifold, Exhaust
70	98-7534	2	Nut
80	105-2893	2	Washer-Spring
90	107-4300	1	Orifice ASM
100	98-7617	1	Joint

--	--	--	--

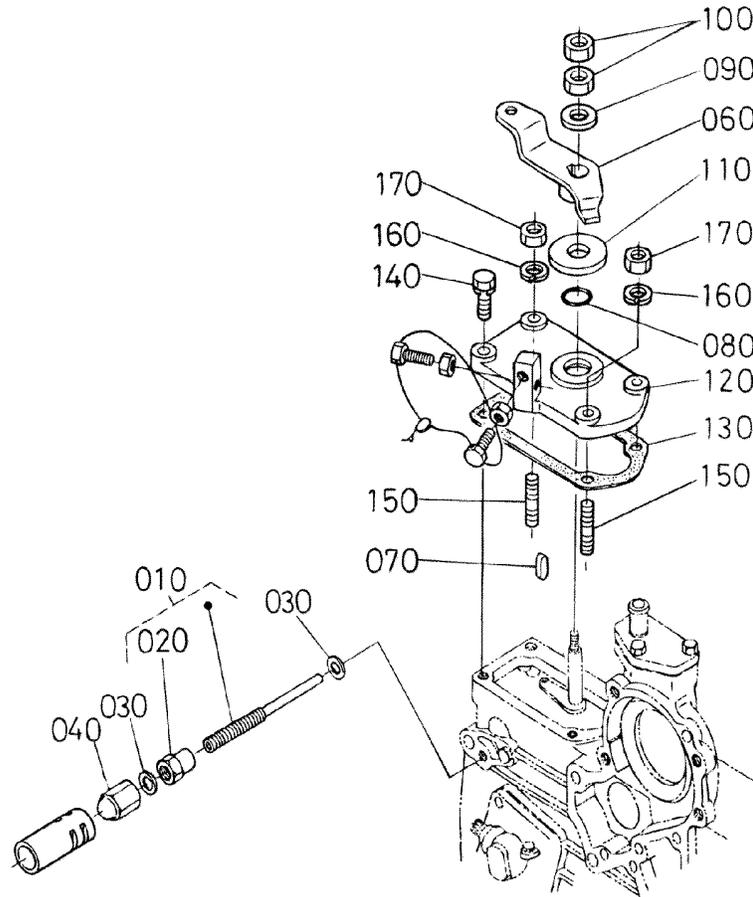

Speed Control Plate Assembly

Ref	Part No.	Qty.	Description
10	107-0132	1	Adjustable Bolt ASM
20	98-7653	1	Nut
30	98-7654	2	Gasket
40	98-7655	1	Nut-Cap
60	98-7657	1	Lever-Control, Speed
70	98-7658	1	Key-Feather
80	107-0103	1	O-Ring
90	98-7660	1	Washer-Plain
100	98-7661	2	Nut
110	98-7662	1	Collar
120	98-7663	1	Plate-Control, Speed
130	98-7664	1	Gasket
140	98-7568	2	Bolt
150	98-7571	2	Stud
160	98-7699	2	Washer-Spring
170	98-7572	4	Nut

--	--	--	--

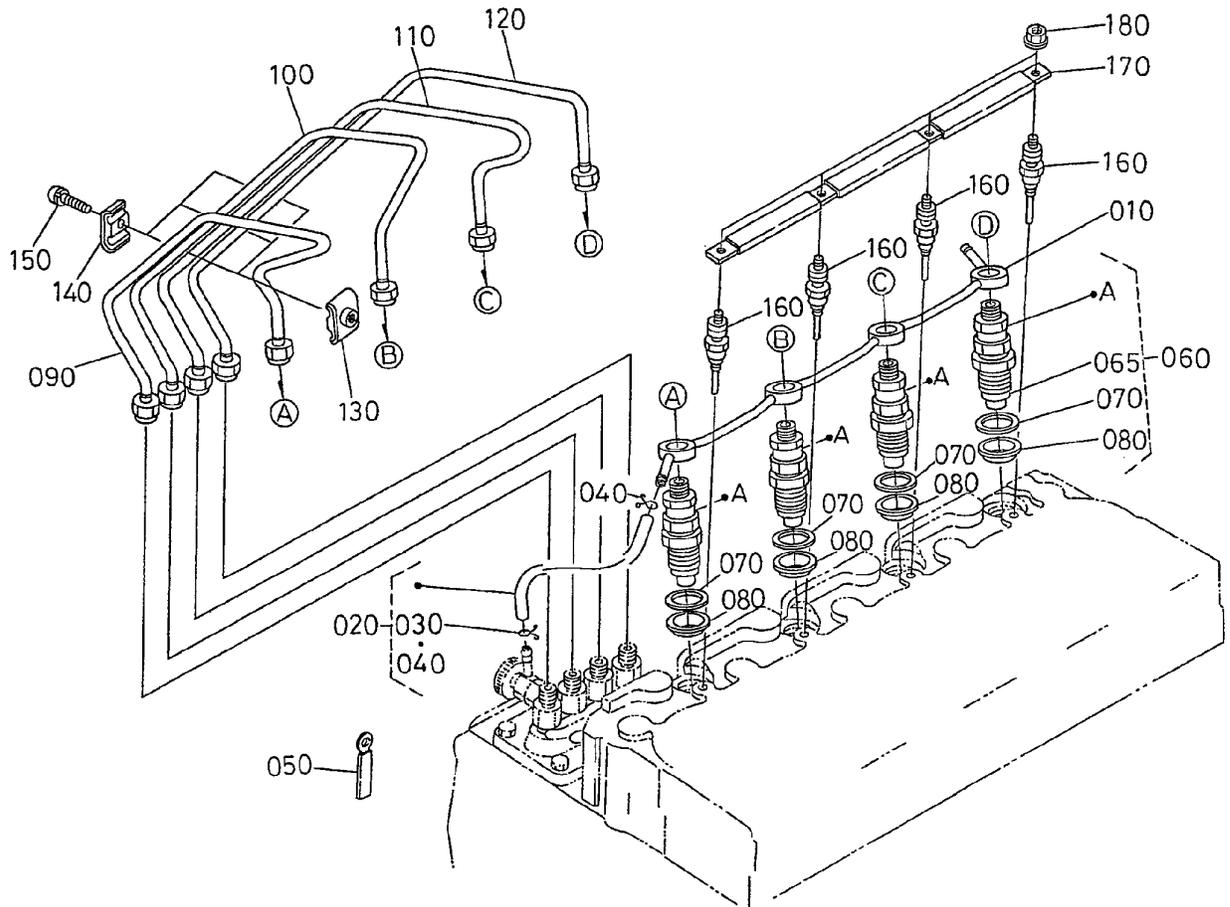

Nozzle Holder and Glow Plug Assembly

Ref	Part No.	Qty.	Description
10	100-9213	1	Overflow Pipe ASM
20	98-7670	1	Overflow Pipe ASM
30	98-7671	1	Clip-Pipe
40	98-7672	1	Clip-Pipe
50	98-7673	1	Clamp-Cord
60	100-9214	1	Nozzle Holder Kit
65	100-9215	4	Piece-Nozzle
70	98-7676	4	Gasket
80	98-7677	4	Seal-Heat
90	100-9216	1	Pipe-Injection
100	100-9217	1	Pipe-Injection
110	100-9218	1	Pipe-Injection
120	100-9219	1	Pipe-Injection
130	98-7682	3	Clamp-Pipe
140	98-7683	3	Clamp-Pipe
150	98-9364	3	Screw (With Washer)
160	98-7685	4	Plug-Glow
170	98-7686	1	Cord-Plug, Glow
180	99-8377	4	Nut-Flange

--	--	--	--

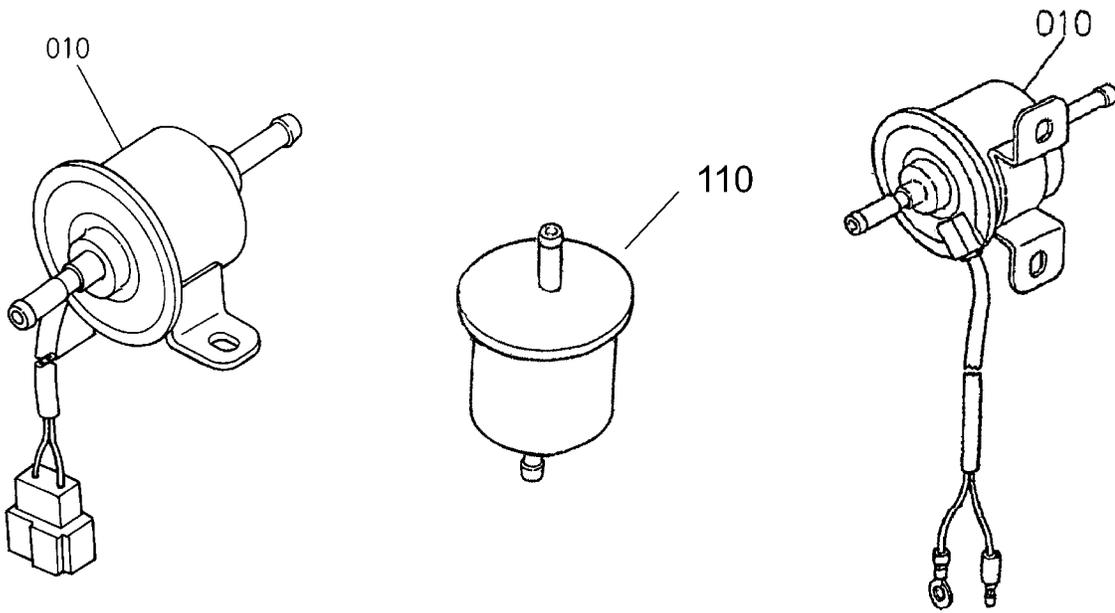

Ref. No. Part No. Engine Serial #
 010 107-0122 (2S0001 or newer)

Ref. No. Part No. Engine Serial #
 010 99-3464 (1U1056 or earlier)

Fuel Filter and Fuel Pump

Ref	Part No.	Qty.	Description
10	99-3464	1	Pump-Fuel
10	107-0122	1	Pump-Fuel, Electric
110	98-7612	1	Filter-Fuel

Ref	Part No.	Qty.	Description

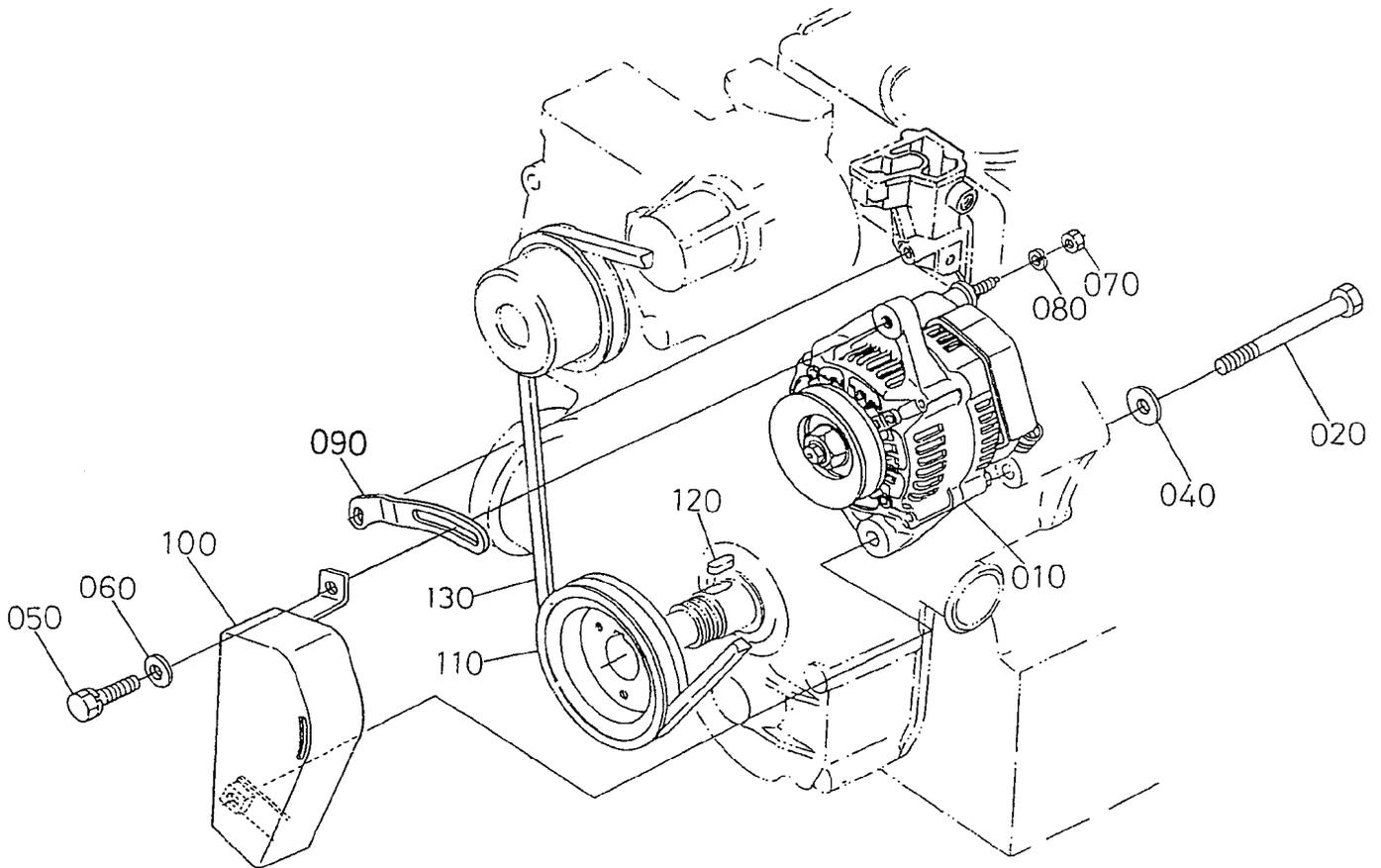

Alternator and Pulley Assembly

Ref	Part No.	Qty.	Description
10	107-0145	1	Alternator ASM
20	98-7695	1	Bolt
40	98-9366	1	Washer-Plain
50	98-7697	1	Bolt
60	100-9233	1	Washer-Plain
70	98-7572	1	Nut
80	98-7699	1	Washer-Spring
90	105-2872	1	Bracket-Alternator
100	98-7701	1	Cover-Belt
110	106-2044	1	Pulley-Drive, Fan
120	98-7451	1	Key-Feather
130	98-7705	1	V-Belt

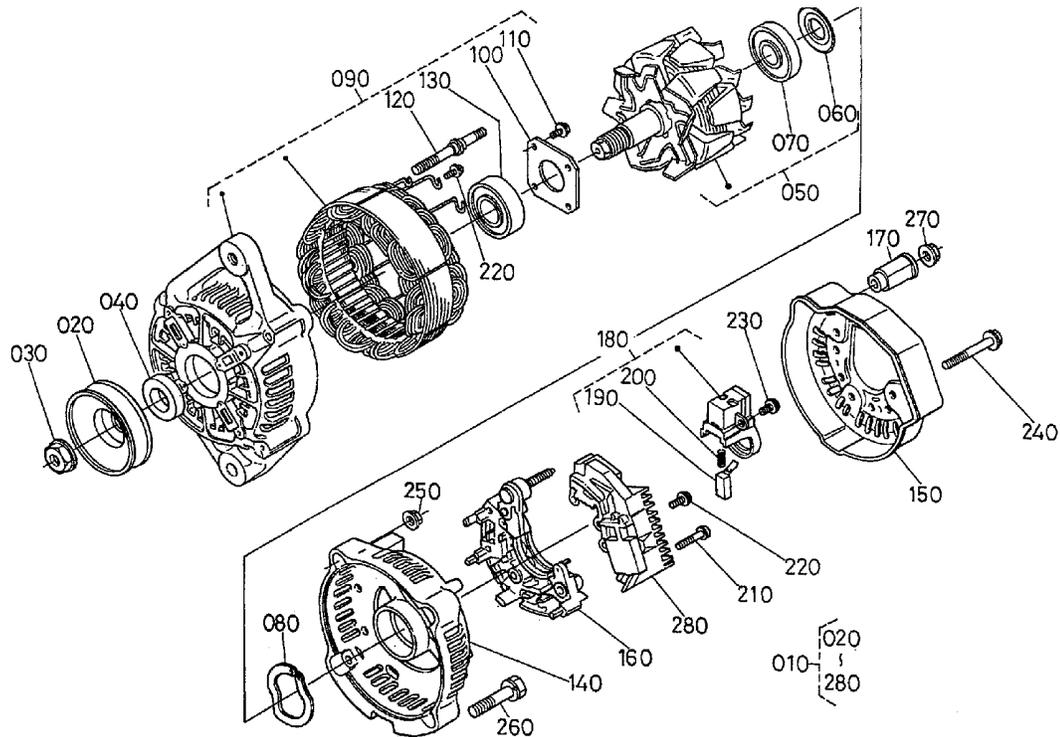

Ref. No.	Part No.	Engine Serial #	Ref. No.	Part No.	Engine Serial #
090	98-7714	(1Q1216 or earlier)	090	107-0139	(1S0001 or newer)
150	98-7720	(1Q1216 or earlier)	150	107-0140	(1S0001 or newer)
180	98-7723	(1Q1216 or earlier)	180	107-0141	(1S0001 or newer)

Alternator Component Parts Assembly

Ref	Part No.	Qty.	Description	Ref	Part No.	Qty.	Description
10	107-0145	1	Alternator ASM	220	98-7727	6	Screw-Head, Round
20	98-7707	1	Pulley-Alternator	230	98-7728	1	Screw-Head, Round
30	98-7708	1	Nut	240	98-7729	3	Bolt
40	98-7709	1	Collar	250	98-7730	2	Nut
50	107-0136	1	Rotor	260	98-7731	2	Bolt
60	98-7711	1	Cover-Bearing	270	98-7732	1	Nut
70	107-0138	1	Bearing-Ball	280	98-7733	1	Regulator ASM
80	98-7713	1	Washer-Thrust				
90	107-0139	1	Drive End Frame ASM				
90	98-7714	1	Frame-End, Drive				
100	98-7715	1	Plate-Retainer				
110	98-7716	4	Screw-Head, Round				
120	98-7717	2	Bolt-Through				
130	107-0137	1	Bearing-Ball				
140	98-7719	1	Frame-End				
150	98-7720	1	Cover-End				
150	107-0140	1	Cover-End				
160	98-7721	1	Rectifier ASM				
170	98-7722	1	Bushing-Insulation				
180	98-7723	1	Holder-Brush				
180	107-0141	1	Holder-Brush				
190	98-7724	2	Brush				
200	98-7725	2	Spring-Brush				
210	98-7726	2	Screw-Head, Round				

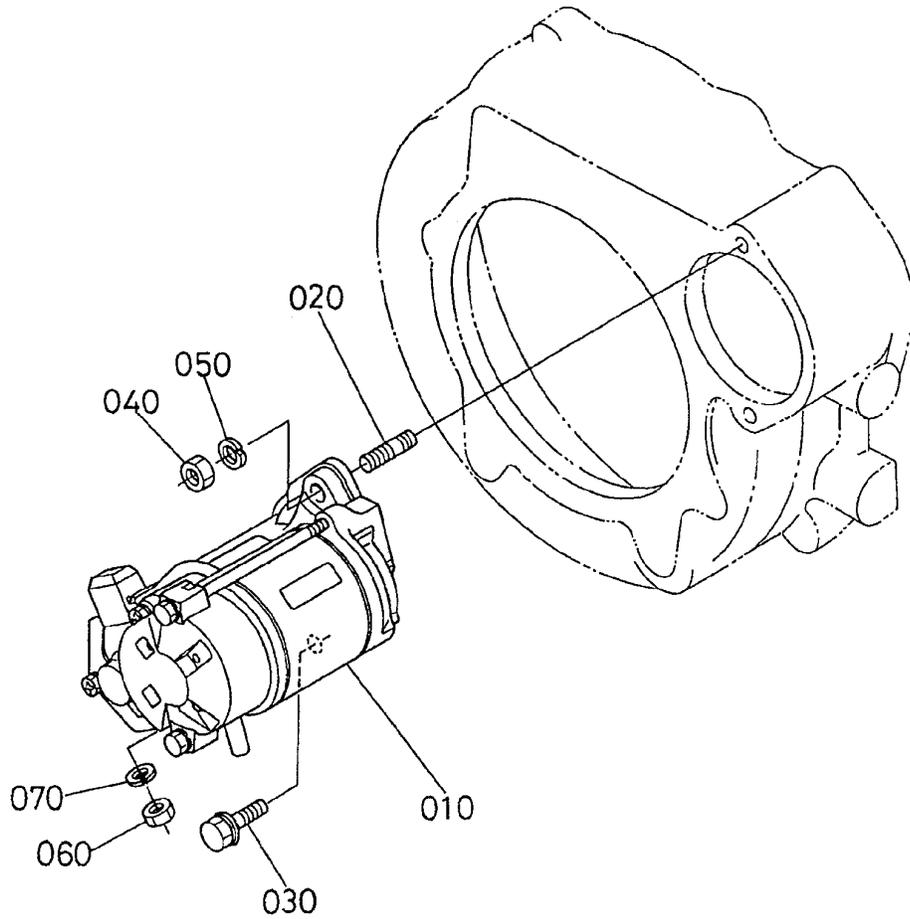

Starter Assembly

Ref	Part No.	Qty.	Description
10	100-9237	1	Starter ASM
20	98-7735	1	Stud
30	98-7736	1	Bolt
40	99-7526	1	Nut
50	98-7738	1	Washer-Spring
60	98-7739	1	Nut
70	105-2893	1	Washer-Spring

--	--	--	--

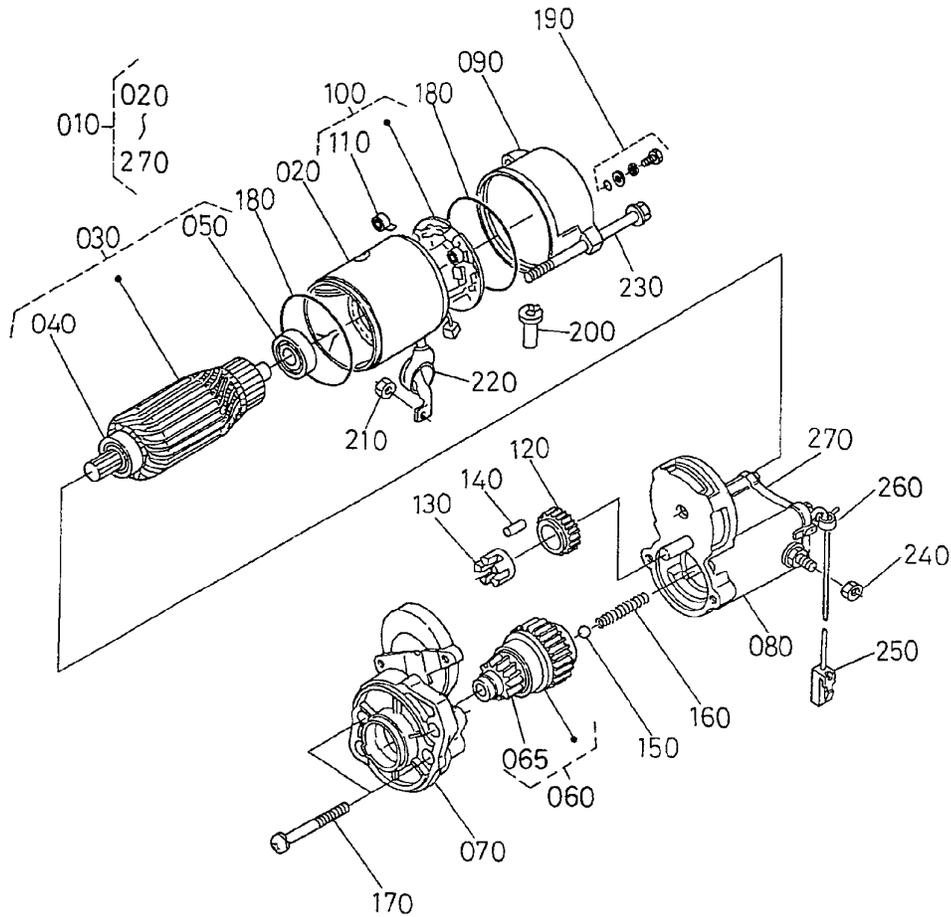

Starter Component Parts Assembly

Ref	Part No.	Qty.	Description
10	100-9237	1	Starter ASM
20	104-8608	1	Yoke ASM
30	98-7742	1	Armature ASM
40	98-7744	1	Bearing
50	98-7743	1	Bearing
60	98-7745	1	Clutch-Running, Over
65	105-2887	1	Pinion-Bevel
70	98-7746	1	Frame-End, Drive
80	100-9239	1	Magnetic Switch ASM
90	98-7748	1	Frame-End
100	98-7749	1	Brush Holder ASM
110	98-7750	4	Spring-Brush
120	98-7751	1	Gear
130	98-7752	1	Retainer
140	98-7753	5	Roller
150	98-7755	1	Ball
160	98-7754	1	Spring
170	98-7756	2	Bolt
180	98-7757	2	O-Ring
190	98-7758	2	Bolt ASM
200	98-7759	1	Pipe-Drain
210	105-2873	1	Nut
220	99-8375	1	Cover
230	100-9240	2	Bolt

Ref	Part No.	Qty.	Description
240	99-8376	1	Nut-Hex
250	98-9711	1	Cord-Solenoid, Stop
260	98-9712	1	Band-Cover
270	105-2886	1	Cover ASM

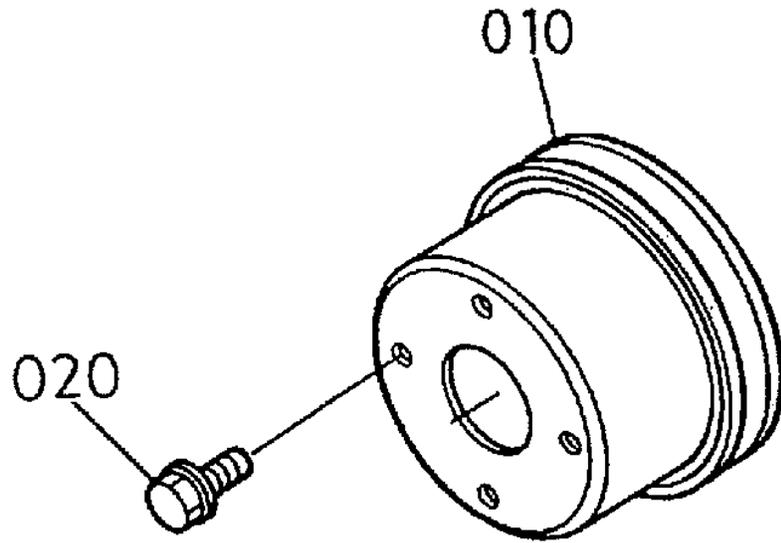

Fan Assembly

Ref	Part No.	Qty.	Description
10	98-7702	1	Pulley-Fan
20	99-8363	4	Bolt-Flange

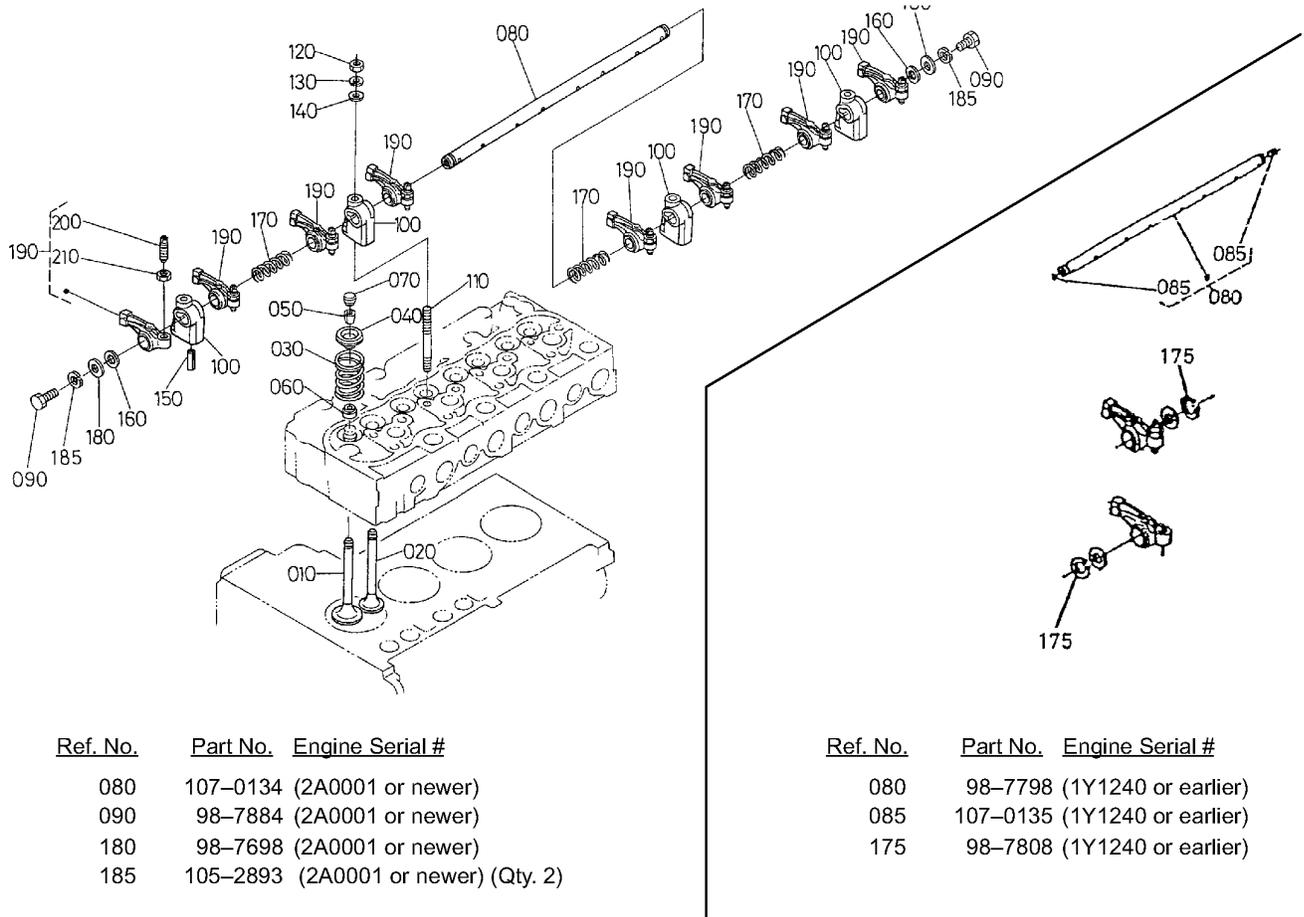

Ref. No.	Part No.	Engine Serial #
080	107-0134	(2A0001 or newer)
090	98-7884	(2A0001 or newer)
180	98-7698	(2A0001 or newer)
185	105-2893	(2A0001 or newer) (Qty. 2)

Ref. No.	Part No.	Engine Serial #
080	98-7798	(1Y1240 or earlier)
085	107-0135	(1Y1240 or earlier)
175	98-7808	(1Y1240 or earlier)

Valve and Rocker Arm Assembly

Ref	Part No.	Qty.	Description
10	98-7791	4	Valve-Inlet
20	100-9281	4	Valve-Exhaust
30	98-7793	8	Spring-Valve
40	98-7794	8	Retainer-Spring, Valve
50	98-7795	8	Collet-Spring, Valve
60	98-7796	8	Seal-Stem, Valve
70	98-7797	8	Cap-Valve
80	107-0134	1	Shaft-Arm, Rocker
80	98-7798	1	Rocker Arm Shaft ASM
85	107-0135	2	Screw-Set
90	98-7884	2	Bolt
100	98-7800	4	Bracket-Arm, Rocker
110	98-7801	4	Stud
120	98-7534	4	Nut
130	105-2893	4	Washer-Spring
140	98-7536	4	Washer-Plain
150	98-7805	1	Pin-Spring
160	98-7806	2	Washer
170	98-7807	3	Spring-Arm, Rocker
175	98-7808	2	Clip-Cir., External
180	98-7660	2	Washer-Plain
185	105-2893	2	Washer-Spring
190	98-7809	8	Rocker Arm ASM
200	98-7810	8	Screw-Adjusting

Ref	Part No.	Qty.	Description
210	98-7811	8	Nut

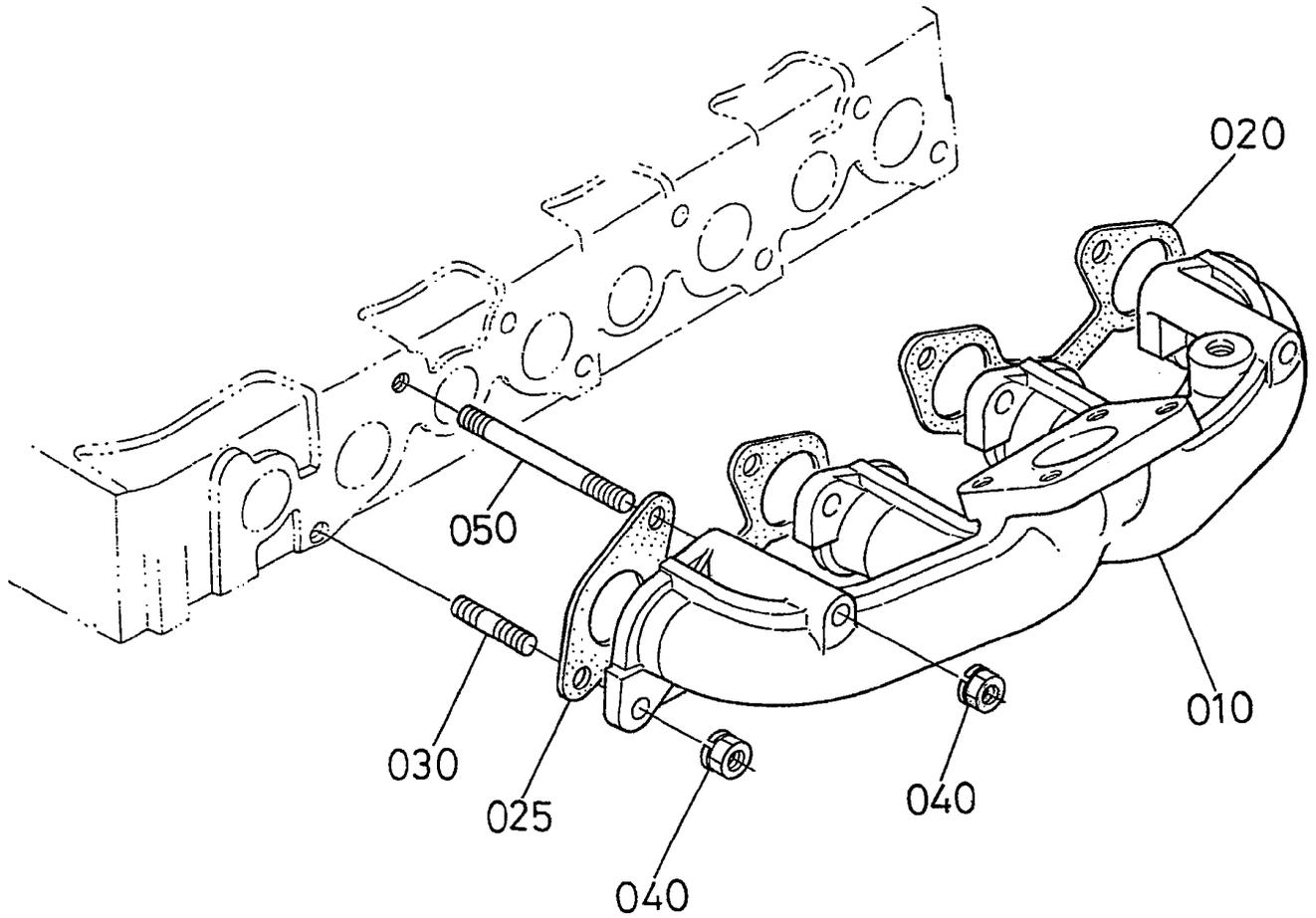

Exhaust Manifold Assembly

Ref	Part No.	Qty.	Description
10	100-9285	1	Manifold-Exhaust
20	98-7802	1	Gasket
25	98-7803	1	Gasket
30	100-1558	6	Stud-Manifold, Exhaust
40	100-9288	8	Nut
50	100-9289	2	Stud

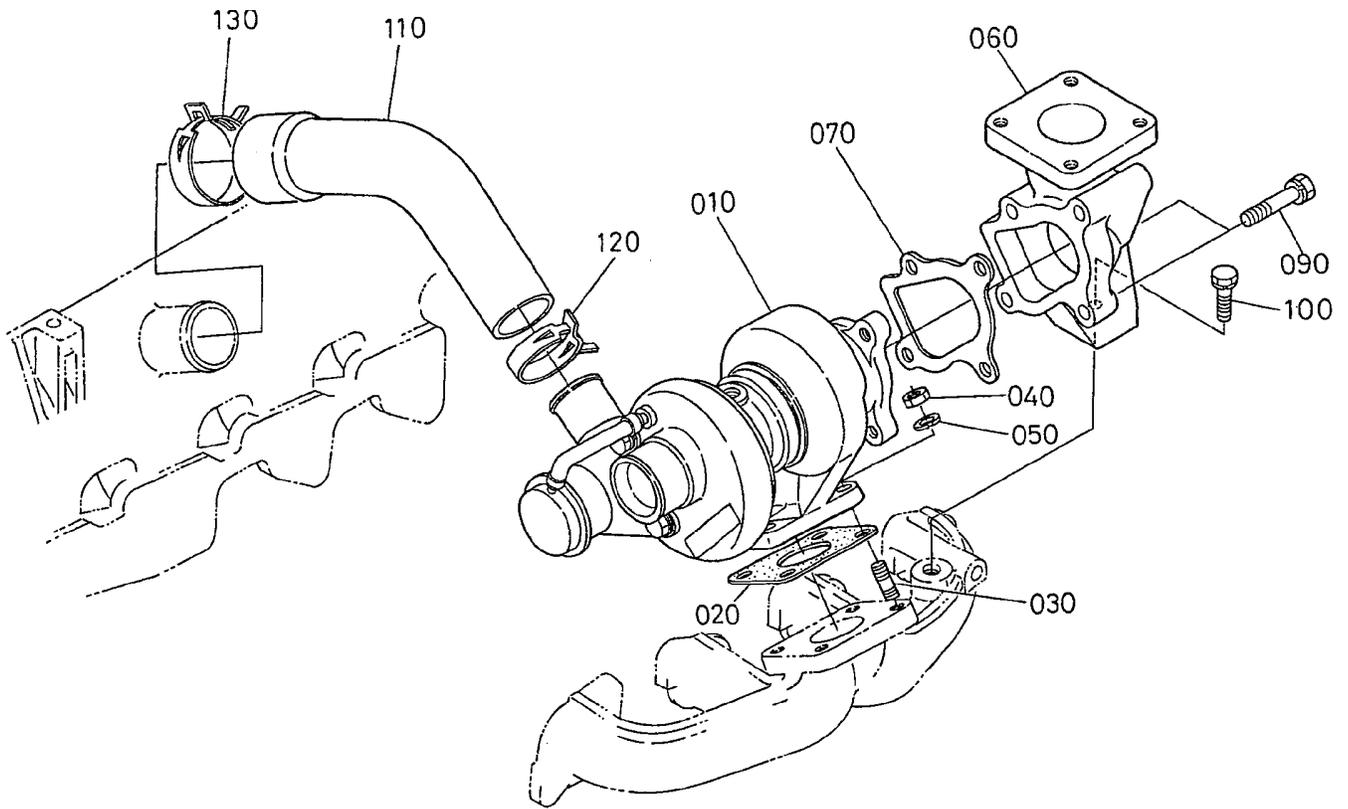

Turbo Charger Assembly

Ref	Part No.	Qty.	Description
10	100-9313	1	Turbo Charger ASM
20	100-9314	1	Gasket
30	99-8342	4	Stud
40	98-7534	4	Nut
50	105-2893	4	Washer-Spring
60	100-9315	1	Flange-Muffler
70	100-9316	1	Gasket
90	98-7697	4	Bolt
100	100-9230	1	Bolt
110	100-9318	1	Hose-Inlet
120	100-9319	1	Band-Pipe
130	99-8322	1	Band-Pipe

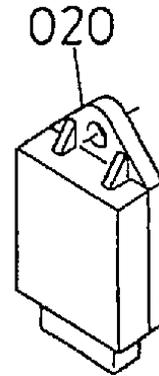
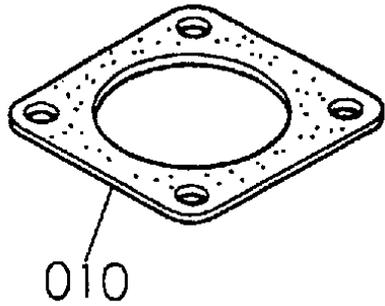

Muffler Gasket and Glow Controller

Ref	Part No.	Qty.	Description
10	100-9333	1	Gasket-Muffler
20	98-7611	1	Controller-Glow

|--|--|--|--|

NOTES

NOTES

