



## Z17-44 TimeCutter™ Z Riding Mower

Model No. 74601 - 210000001 and up.

### Parts Catalog

---

#### **Ordering Replacement Parts**

To order replacement parts, please supply the part number, the quantity, and the description of each part desired.

#### **Understanding Reference Numbers**

Each identified part in an illustration has a reference number. The reference number for a part also appears in the parts list, along with other information about the part.

This catalog uses two special reference number formats, one to indicate parts in a service assembly and another to indicate the quantity of a given part in an illustration.

#### **Service Assembly Reference Numbers**

Parts in service assemblies have reference numbers in the form a:b. The a represents the reference number of the entire service assembly and the b represents a sequential number unique to each part within the service assembly.

For example, a wheel assembly might be identified by reference number 6, the tire by 6:1, the valve by 6:2, and the wheel by 6:3. When you order the assembly identified by reference number 6, you receive all parts identified by reference numbers 6:1, 6:2, and 6:3. However, you may also order any part individually. Reference numbers of this type appear in illustrations and in part lists.

#### **Reference Numbers Indicating Quantity**

In an illustration, if a reference number indicates more than one part, the reference number has the form nX y. The n represents the quantity of the part, the X is the multiplication symbol, and the y represents the reference number.

For example, in an illustration, the reference number 2X 37 means that two of the parts identified by reference number 37 are indicated.

# Contents

Description	Page	Description	Page
Front Frame Assembly	3	Crankcase Assembly Kohler CV 490-27503	20
Height-of-Cut Assembly	4	Oil Pan / Lubrication Assembly Kohler CV 490-27503	21
Main Frame Assembly	5	Head / Valve / Breather Assembly Kohler CV 490-27503	22
Fuel Tank Assembly	6	Ignition / Electrical Assembly Kohler CV 490-27503	23
Parking Brake Assembly	7	Blower Housing and Baffle Assembly Kohler CV 490-27503	24
Motion Control Assembly	8	Starting System Assembly Kohler CV 490-27503	25
Hydro And Belt Drive Assembly	9	Fuel System Assembly Kohler CV 490-27503	26
Engine And Clutch Assembly	10	Engine Control Assembly Kohler CV 490-27503	27
Electrical Assembly	11	Air Intake / Filtration Assembly Kohler CV 490-27503	28
44 Inch Deck Assembly	12	Exhaust Assembly Kohler CV 490-27503	29
44 Inch Deck Belt Drive And Lift Assembly	13		
Wiring Schematic	14		
Right Hand Hydro Transaxle Assembly No. 100-7360	15		
Left Hand Hydro Transaxle Assembly No. 100-7361	17		
Crankshaft Assembly Kohler CV 490-27503	19		

## Part Description Abbreviations

Part descriptions in this catalog may include the following abbreviations.

AR. .... as required	HYD. .... hydraulic
ASM. .... assembly	LH. .... left hand
BBC. .... blade brake clutch	NI. .... nylon insert
CARR. .... carriage	NPTF. .... national pipe thread fine
DEG. .... degrees	PFH. .... phillips flat head
EXT. .... external	PPH. .... phillips pan head
FH. .... flat head	PPHTF. .... phillips pan head thread forming
GA. .... gauge	PRH. .... phillips round head
HD. .... heavy-duty	PTH. .... phillips truss head
HF. .... hex flange	PTO. .... power-take-off
HH. .... hex head	RH. .... right hand
HHF. .... hex head flange	ROPS. .... roll-over protection system
HHFTF. .... hex head flange thread forming	SFH. .... slotted fillister head
HJ. .... hex jam	SHH. .... slotted hex head
HLH. .... hex lag head	SHWH. .... slotted hex washer head
HOC. .... height-of-cut	SPH. .... slotted pan head
HSBH. .... hex socket button head	SQH. .... square head
HSFH. .... hex socket flat head	SRH. .... slotted round head
HSH. .... hex socket head	STD. .... standard
HWH. .... hex washer head	TAP. .... self tapping
HWHTF. .... hex washer head thread forming	TTH. .... torx truss head

## Footnotes

- ❶ Not illustrated
- ❷ Not serviced
- ❸ Obtain Parts From Kohler

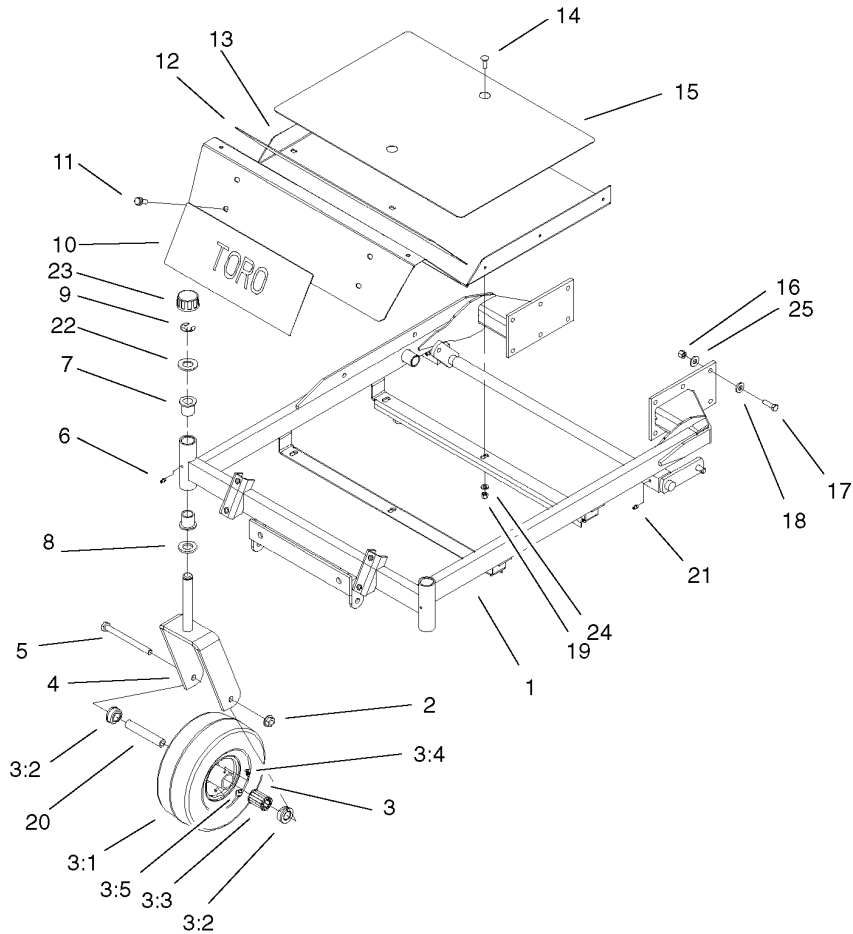

### Front Frame Assembly

Ref	Part No.	Qty.	Description
1	100-7357-01	1	Carrier Frame ASM
2	32128-23	2	Nut-HF
3	100-7364	2	Caster Wheel ASM
3:1	105-1943	1	Tire
3:2	62-5580	2	Bearing-Outside
3:3	83-4740	1	Bearing
3:4	302-11	1	Fitting-Lube, 45 DEG
3:5	232-27	1	Stem-Valve
4	100-7363-01	2	Caster Fork ASM
5	325-22	2	Screw-HH
6	302-5	2	Fitting-Grease
7	1-303514	4	Bearing-Flanged
8	1-513338	2	Washer-Flat
9	32151-103	2	Ring-Retaining, EXT
10	104-8016	1	Decal
11	66-9300	4	Screw-HF
12	104-3639	1	Pad-Skid, Anti
13	100-7386-03	1	Floorpan
14	3230-28	6	Screw-CARR
15	104-3640	1	Pad-Skid, Anti
16	3296-39	12	Nut-Lock, NI
17	323-7	12	Screw-HH
18	98-5975	12	Washer-Belleville
19	3296-29	6	Nut-Lock, NI

Ref	Part No.	Qty.	Description
20	104-3667	2	Spanner-Wheel
21	302-19	2	Fitting-Grease
22	104-8076	2	Washer
23	61-9780	2	Cap-Hub
24	3256-23	6	Washer-Flat
25	1-809107	12	Washer-Hardened



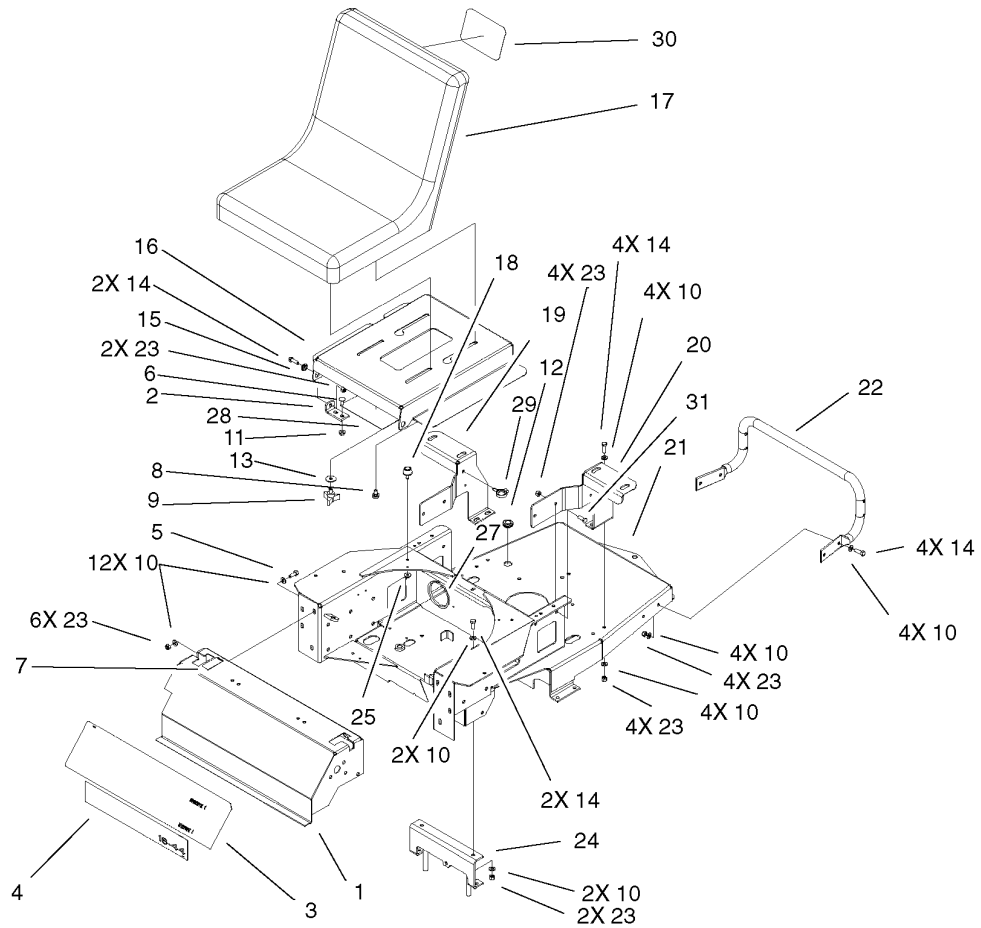

## Main Frame Assembly

Ref	Part No.	Qty.	Description
1	104-8040-03	1	Console
2	104-8057-03	2	Bracket-Pivot
3	104-8014	1	Decal-Console
4	104-8084	1	Decal
5	322-4	6	Screw-HH
6	104-8049	4	Screw-CARR
7	1-633354	2	Decal-Control, Motion
8	37-8770	2	Bolt-Shoulder
9	92-9674	2	Knob
10	3256-23	32	Washer-Flat
11	32128-25	4	Nut-HF
12	237-124	1	Grommet
13	5-4460	2	Washer-Pivot
14	322-5	12	Screw-HH
15	105503	2	Bushing
16	104-8058-03	1	Pan-Seat
17	104-3690	1	Seat
18	1-523420	2	Bumper
19	100-7376-01	1	Bracket-RH
20	100-7368-01	1	Bracket-LH
21	100-7367-01	1	Frame-Rear
22	100-7332-03	1	Rod-Support, Rear
23	3296-29	22	Nut-Lock, NI
24	104-3676-03	1	Bracket-Hydro Front

Ref	Part No.	Qty.	Description
25	32128-33	2	Nut-HF
27	105-1854	1	Cover-Conduit
28	104-8088	1	Decal-Service
29	105-1853	2	Clamp-Hose
30	93-7340	1	Decal
31	322-3	4	Screw-HH



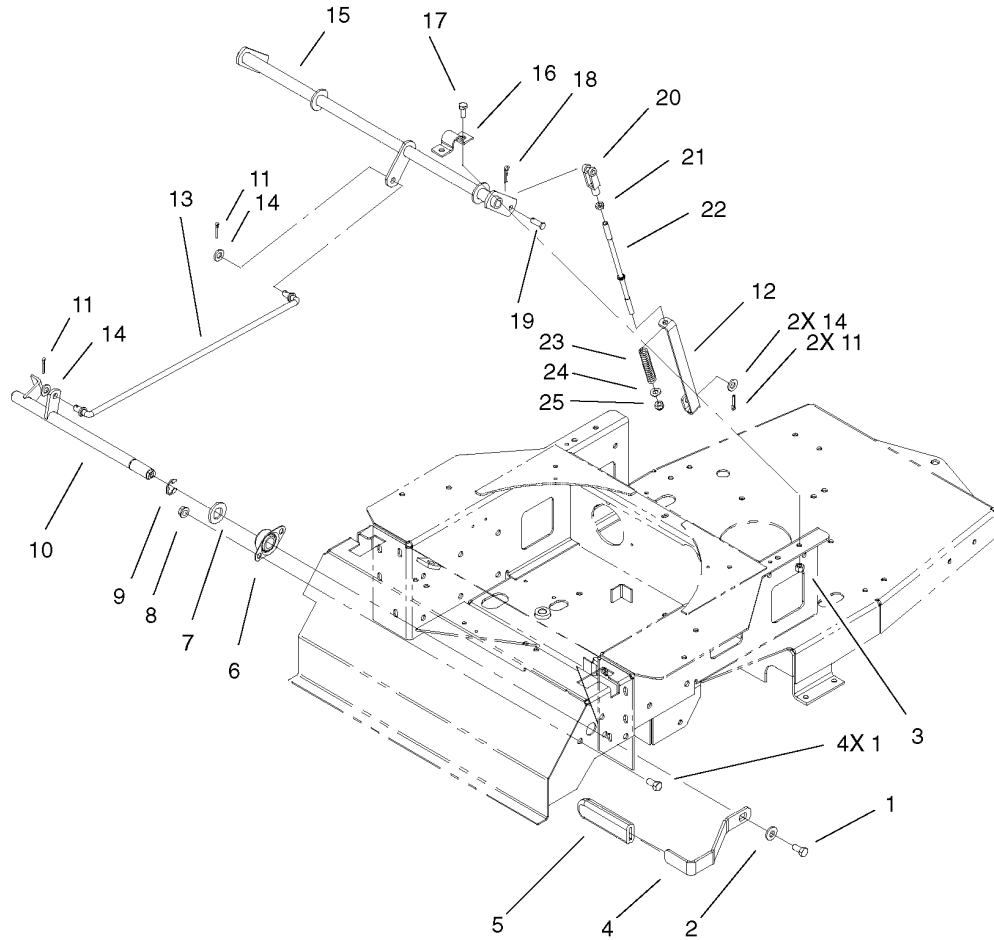

## Parking Brake Assembly

Ref	Part No.	Qty.	Description
1	323-4	5	Screw-HH
2	98-5975	1	Washer-Belleville
3	3296-29	4	Nut-Lock, NI
4	100-7346-03	1	Handle-Brake, Park
5	1-633268	1	Grip-Lever, Brake
6	1-633102	2	Bearing-Flange, Side
7	3256-28	1	Washer-Flat
8	3290-357	4	Nut-HHF, Whiz
9	32151-48	1	E-Ring
10	100-7318	1	Brake Shaft ASM
11	3272-10	4	Pin-Cotter
12	104-3675	2	Bracket-Spring, Brake
13	104-8046	1	Rod-Brake, Upper
14	3256-24	4	Washer-Flat
15	104-3670-03	1	Shaft-Brake
16	88-4730	2	Clamp-Pivot, HOC
17	322-3	4	Screw-HH
18	1-806003	2	Pin-Hair
19	1-808280	2	Pin-Clevis
20	1-303105	2	Yoke-Adjustable
21	3219-2	2	Nut-Hex
22	104-3674	2	Rod-Brake, Upper
23	38-4520	2	Spring
24	3256-23	2	Washer-Flat

Ref	Part No.	Qty.	Description
25	3296-4	2	Nut-Lock

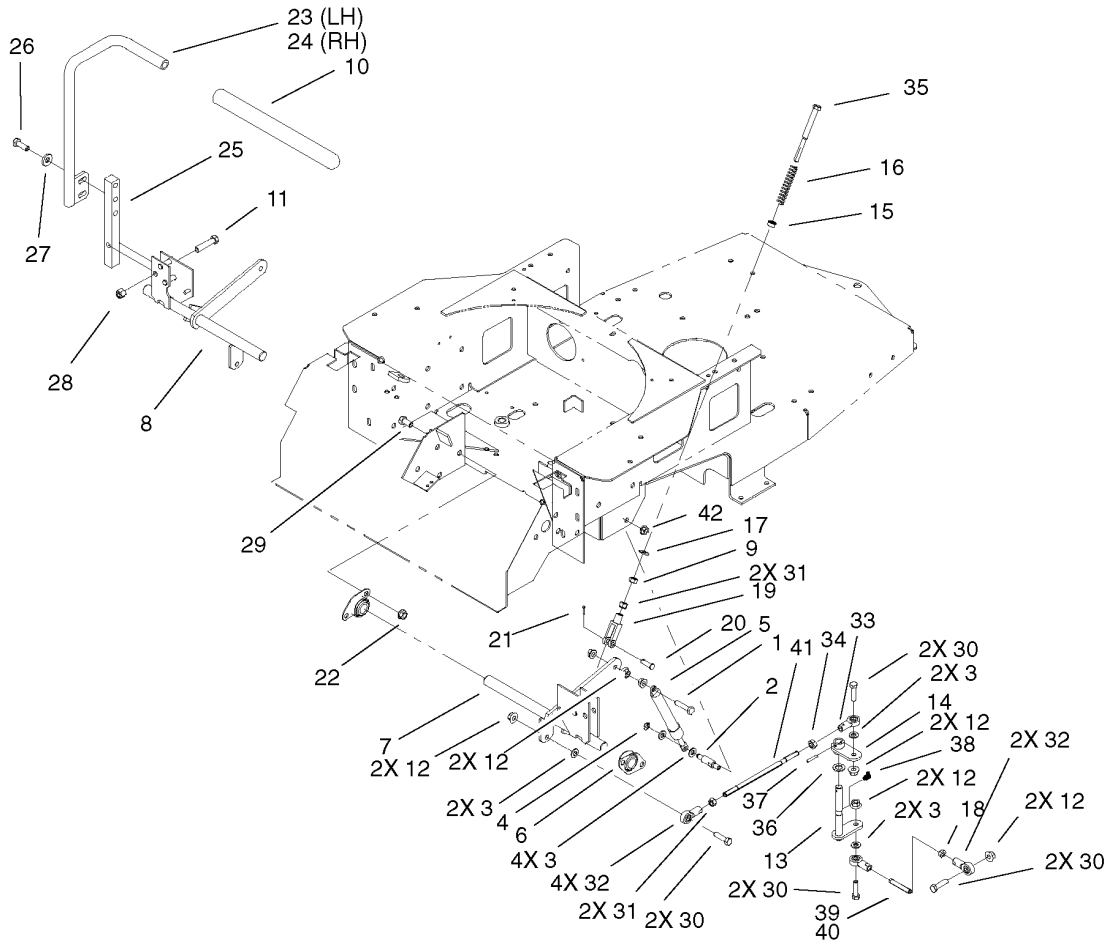

## Motion Control Assembly

Ref	Part No.	Qty.	Description
1	1-403180	2	Screw-HH
2	1-653316	2	Pin-Damper
3	3256-23	10	Washer-Flat
4	32120-35	2	Ring-Retaining, EXT
5	103-2913	2	Damper-Control, Motion
6	1-633102	4	Bearing-Flange, Side
7	100-7341	1	Bracket-Motion Control, LH
8	100-7340	1	Bracket-Motion Control, RH
9	3296-4	2	Nut-Lock
10	1-633257	2	Grip-Control, Motion
11	323-9	2	Screw-HH
12	32128-20	10	Nut-HF
13	100-7311	2	Pivot ASM
14	100-7313	2	Pivot Plate ASM
15	1-603735	2	Bushing-Flanged
16	1-603807	2	Spring-Return, Neutral
17	3256-2	2	Washer-Flat
18	3220-2	2	Nut-Jam
19	1-303105	2	Yoke-Adjustable
20	1-808280	2	Pin-Clevis
21	3272-5	2	Pin-Cotter
22	3290-357	6	Nut-HHF, Whiz
23	103-0409-03	1	Lever-Control, LH
24	103-0410-03	1	Lever-Control, RH

Ref	Part No.	Qty.	Description
25	103-0407	2	Arm-Shaft, Control
26	323-6	4	Screw-HH
27	98-5975	4	Washer-Belleville
28	3296-39	2	Nut-Lock, NI
29	323-4	6	Screw-HH
30	322-5	8	Screw-HH
31	3219-2	4	Nut-Hex
32	1-543017	6	Balljoint-RH
33	1-633152	2	Balljoint-LH
34	1-804524	2	Nut
35	1-603737	2	Bolt-Return, Neutral
36	100-7336	2	Washer
37	933156	2	Pin-Roll
38	302-11	2	Fitting-Lube, 45 DEG
39	104-3606	1	Linkage-Lower, RH
40	104-3607	1	Linkage-Lower, LH
41	104-3605	2	Linkage-Upper
42	32128-25	6	Nut-HF

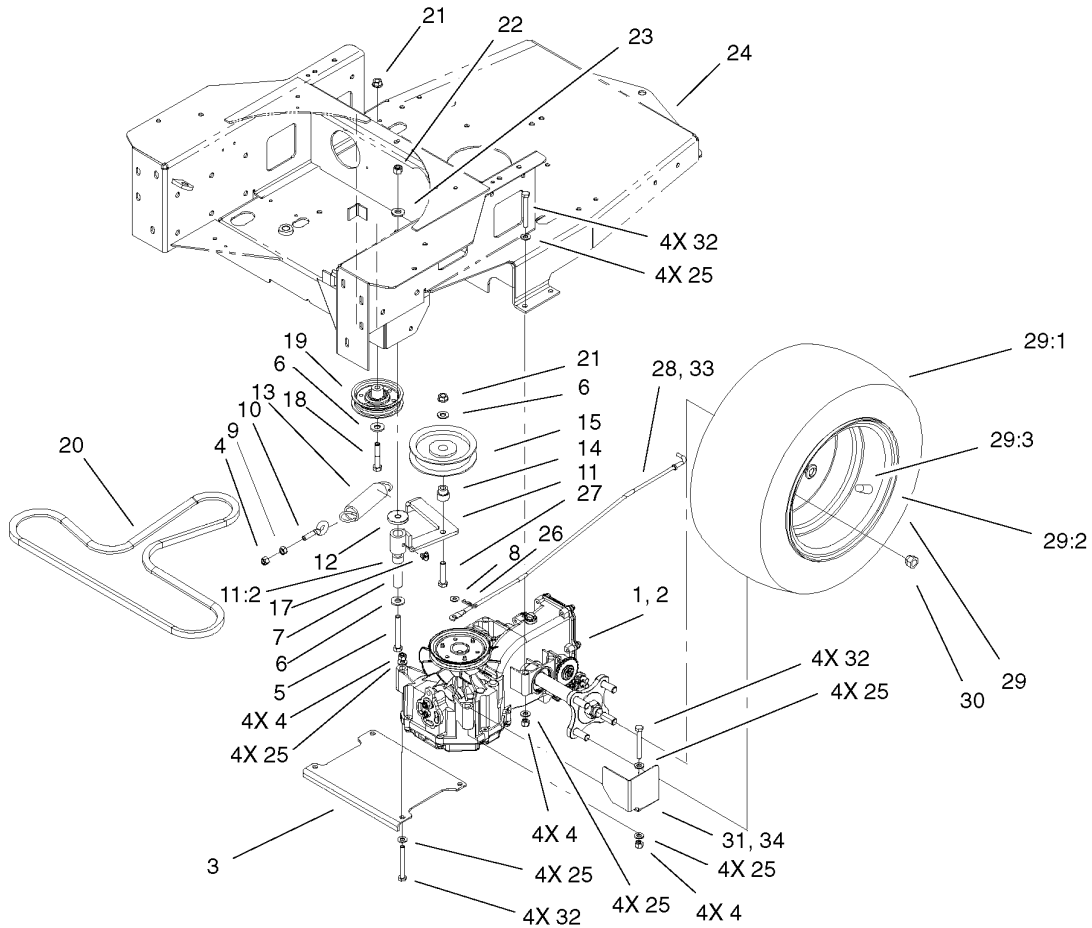

## Hydro And Belt Drive Assembly

Ref	Part No.	Qty.	Description
1	100-7361	1	Hydro-LH
2	100-7360	1	Hydro-RH
3	100-7317-03	1	Plate-Hydro, Lower
4	3296-29	13	Nut-Lock, NI
5	323-13	1	Screw-HH
6	3256-4	3	Washer-Flat
7	1-603044	1	Bushing
8	3256-1	2	Washer-Flat
9	32128-20	1	Nut-HF
10	55-9420	1	Bolt-Eye
11	104-3614	1	Idler Arm ASM
11:2	1-513034	2	Sleeve-Bearing
12	104-8005	1	Spacer
13	1-603414	1	Spring-Extension
14	1-603496	1	Bushing-Idler
15	1-603843	1	Pulley-Idler
17	302-40	1	Fitting-Grease
18	323-10	1	Screw-HH
19	104-3630	1	Pulley-Idler
20	104-3622	1	Belt-V
21	32128-21	2	Nut-HF
22	3296-39	1	Nut-Lock, NI
23	98-5975	1	Washer-Belleville
24	104-8008	1	Decal-Transport

Ref	Part No.	Qty.	Description
25	3256-23	24	Washer-Flat
26	1-806003	2	Pin-Hair
27	323-9	1	Screw-HH
28	104-3669	1	Rod-LH
29		2	Wheel And Tire ASM
29:1	105-1944	1	Tire
29:2	105-1946	1	Wheel
29:3	232-27	1	Stem-Valve
30	105-4070	1	Tube-Inner
31	104-8013-03	1	Guard-Fan, RH
32	322-13	12	Screw-HH
33	104-3668	1	Rod-RH
34	104-8033-03	1	Guard-Fan, LH

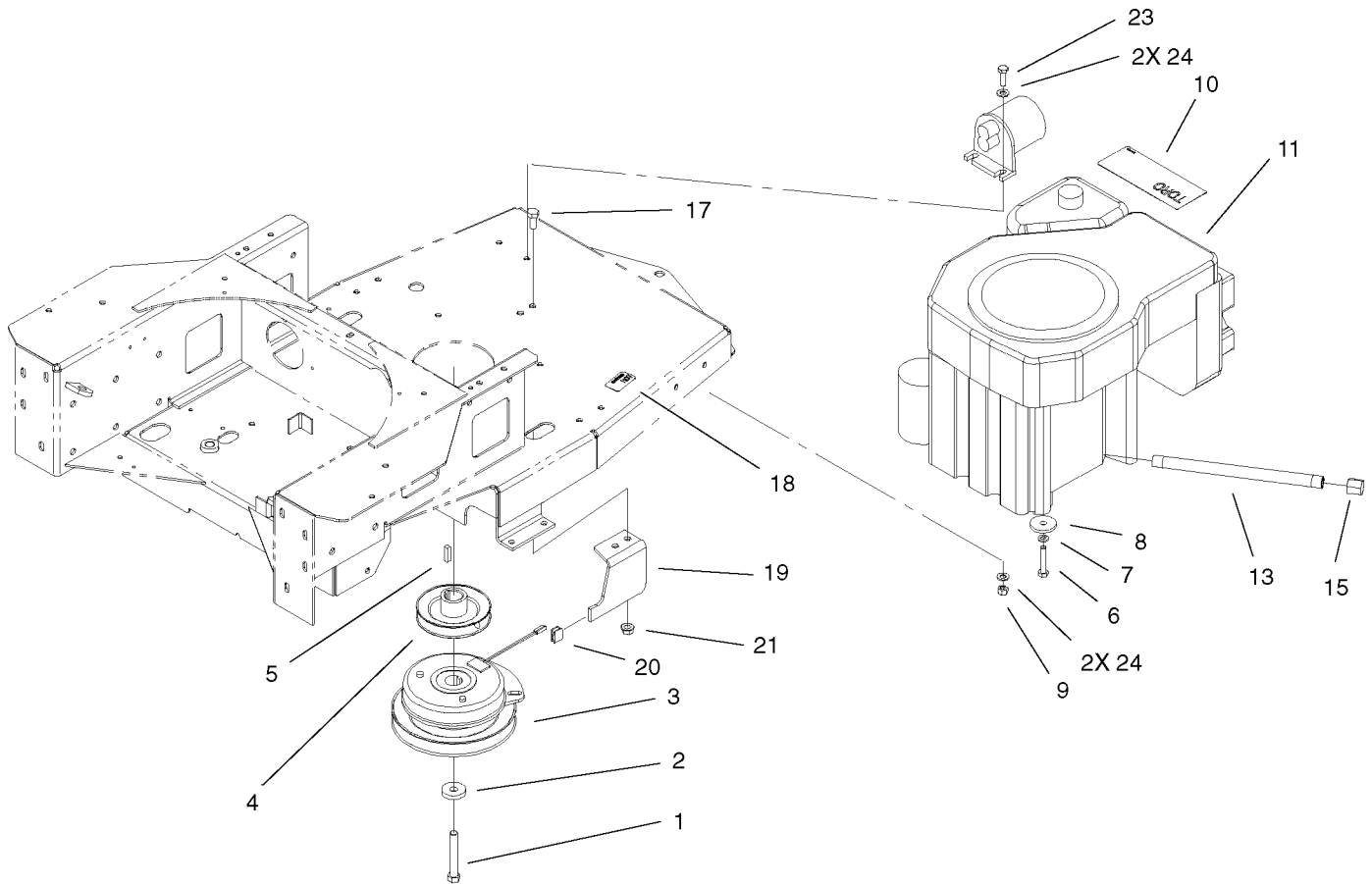

## Engine And Clutch Assembly

Ref	Part No.	Qty.	Description
1	3212-12	1	Screw-HH
2	112843	1	Washer
3	104-3624	1	Clutch
4	100-7314	1	Pump Drive Pulley ASM
5	5-7280	1	Key
6	33114-030	4	Screw-HH
7	3253-4	4	Washer-Lock
8	62-7190	4	Spacer-Steel
9	3296-29	2	Nut-Lock, NI
10	104-8020	1	Decal-Engine Kohler
11		1	Engine-Kohler, Cv 490-27503
13	104-8018	1	Nipple-Pipe
15	288-10	1	Cap-Pipe
17	323-4	2	Screw-HH
18	65-2690	1	Decal-Surface, Hot
19	104-3613-03	1	Stop-Clutch
20	98-5023	1	Bumper
21	32128-21	2	Nut-HF
23	322-5	2	Screw-HH
24	3256-23	4	Washer-Flat

Ref	Part No.	Qty.	Description

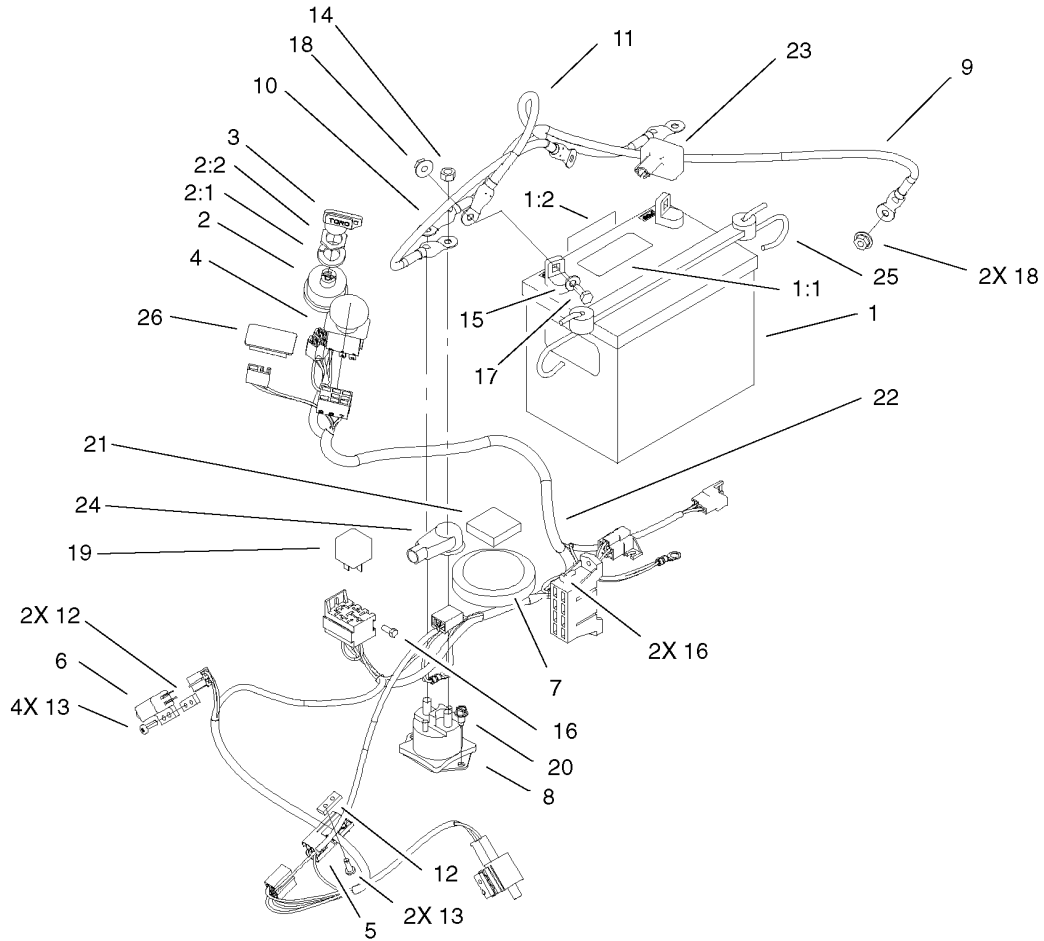

## Electrical Assembly

Ref	Part No.	Qty.	Description
1	104-2491	1	Battery
1:1	104-4163	1	Decal-Battery
1:2	104-5091	1	Decal-Battery
2	88-9830	1	Key Switch ASM
2:1	3254-5	1	Washer-Tooth
2:2	218-461	1	Nut-HH
3	63-8360	1	Key-Ignition
4	95-7489	1	Switch-PTO
5	1-633111	1	Switch
6	65-7410	2	Switch-Pole, Single
7	100-3524	1	Switch-Seat
8	28-4210	1	Solenoid
9	28-3891	1	Wire-Solenoid/Starter
10	93-1189	1	Wire ASM
11	93-0324	1	Cable
12	1-633181	3	Plate-Tapped
13	32144-8	6	Screw-PPHTF
14	32149-1	2	Nut-Keps
15	3256-22	2	Washer-Flat
16	32144-1	3	Screw-Taptite
17	321-4	2	Screw-HH
18	32128-33	3	Nut-HF
19	98-7249	1	Relay
20	32144-4	2	Screw-HWH

Ref	Part No.	Qty.	Description
21	104-2488	1	Foam-Switch, Seat
22	104-3686	1	Harness-Wire Kohler
23	28-8080	1	Boot-Terminal
24	93-3190	1	Boot-Insulator, Terminal
25	104-2466	1	Holddown-Battery
26	99-7420	1	Plug-Hole

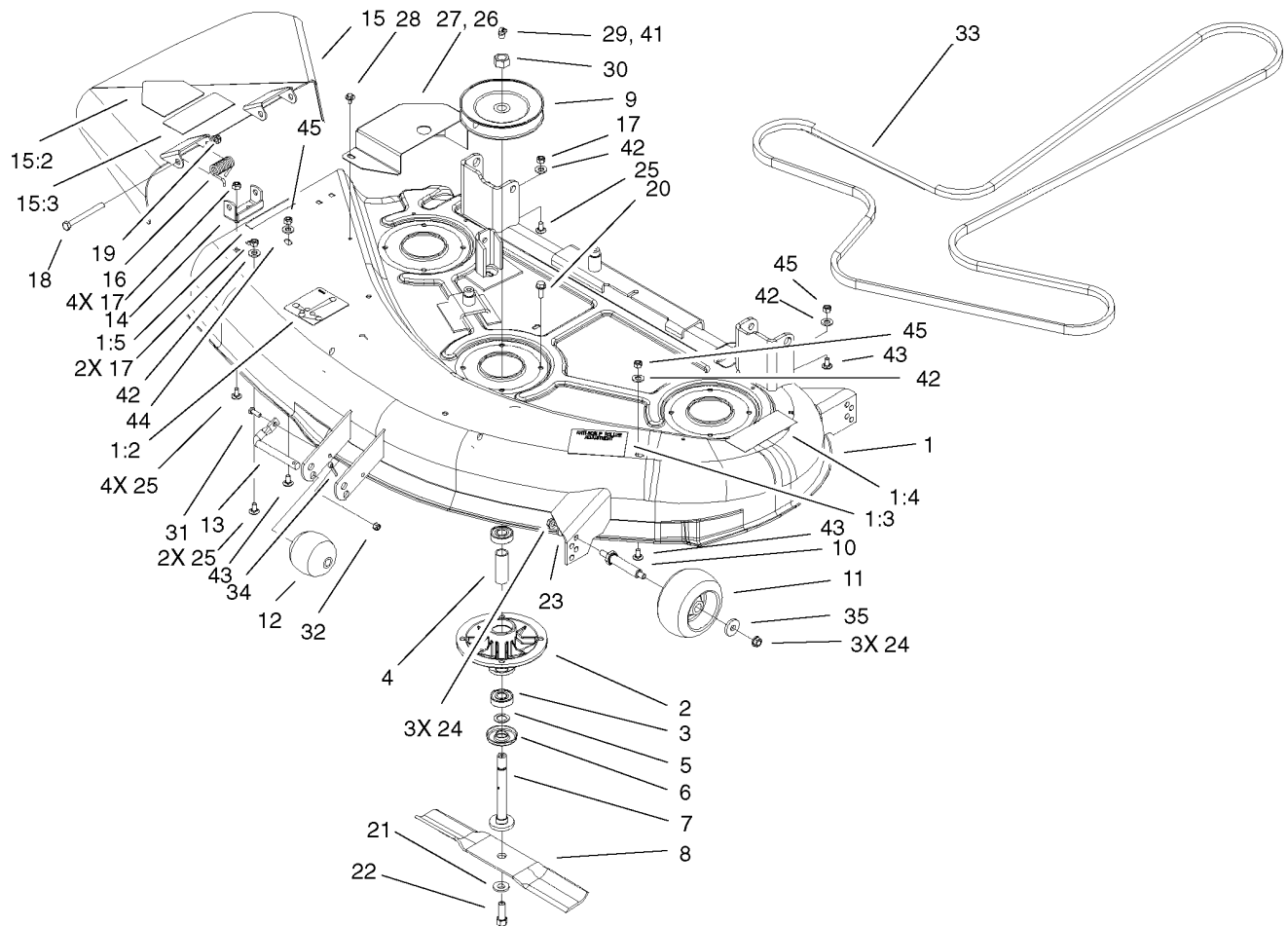

### 44 Inch Deck Assembly

Ref	Part No.	Qty.	Description
1	105-1948	1	44 Inch Deck ASM
1:2	99-3943	1	Decal-Routing, Belt
1:3	98-3798	1	Decal-Wheel, Gage
1:4	92-7108	1	Decal-Danger
1:5	92-7109	1	Decal-Caution
2	88-4510	3	Housing-Spindle
3	109966	6	Bearing-Ball
4	94-7959	3	Spacer - Bearing
5	80-4380	3	Spacer
6	80-4360	3	Shield-Bearing
7	94-7547	3	Shaft-Center, Spindle
8	54-0010-03	3	Blade
9	100-7321	3	Pulley ASM
10	99-2842	3	Spacer
11	68-2730	3	Wheel-Gage
12	29-4820	1	Roller
13	118960-03	1	Shaft-Roller
14	29-5590-03	2	Bracket-Pivot
15	100-8003	1	Deflector/Decal ASM
15:2	93-1122	1	Decal-Danger
15:3	92-7108	1	Decal-Danger
16	40-6230	2	Spring
17	3296-29	7	Nut-Lock, NI
18	3211-15	2	Screw-HH

Ref	Part No.	Qty.	Description
19	3296-5	2	Nut-Lock
20	32144-41	12	Screw-Taptite
21	3290-465	3	Washer-Belleville
22	26-0671	3	Screw-Blade
23	98-5975	3	Washer-Belleville
24	3290-357	6	Nut-HHF, Whiz
25	3230-18	7	Screw-CARR
26	104-3646-01	1	Cover-Belt, LH
27	104-3645-01	1	Cover-Belt, RH
28	46-8560	4	Screw-HHF
29	302-5	2	Fitting-Grease
30	3219-6	3	Nut-Hex
31	321-4	1	Screw-HH
32	3296-42	1	Nut-Lock, NI
33	98-3780	1	V-Belt-Drive
34	3272-21	1	Pin-Cotter
35	1-373034	3	Washer
41	302-60	1	Fitting-Grease, 90 DEG
42	3256-24	4	Washer-Flat
43	3231-21	2	Screw-CARR
44	3256-5	1	Washer-Flat
45	3296-39	4	Nut-Lock, NI

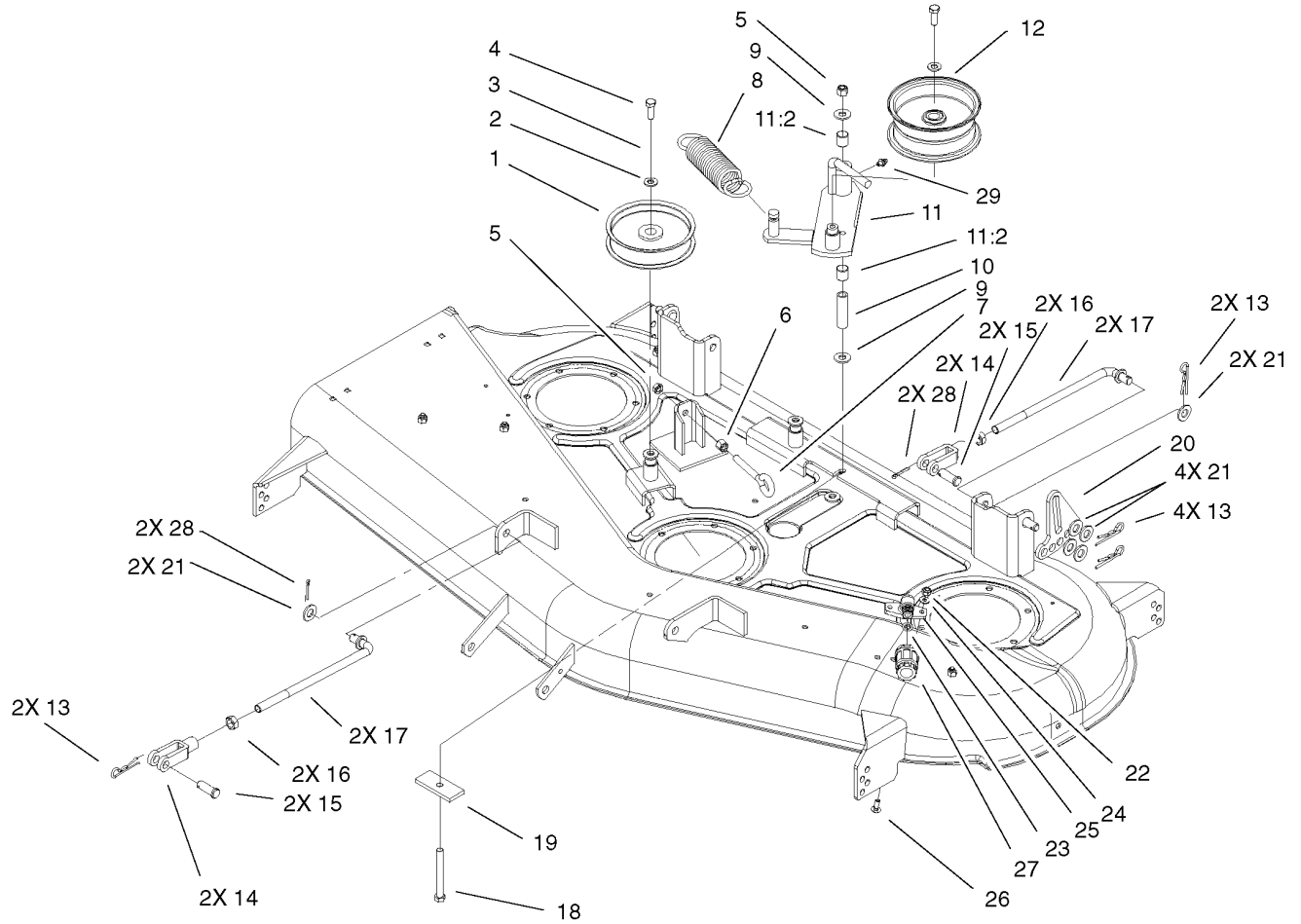

## 44 Inch Deck Belt Drive And Lift Assembly

Ref	Part No.	Qty.	Description
1	1-613098	2	Pulley-Idler
2	3256-24	3	Washer-Flat
3	98-5975	3	Washer-Belleville
4	323-6	3	Screw-HH
5	3296-39	2	Nut-Lock, NI
6	3217-7	1	Nut-Hex
7	94-2547	1	Bolt-Eye
8	1-633151	1	Spring-Extension
9	1-809107	2	Washer-Hardened
10	1-603384	1	Bushing-Pivot, Idler
11	99-3879	1	Idler Arm ASM
11:2	1-513034	2	Sleeve-Bearing
12	1-413099	1	Pulley-Idler
13	1-806005	8	Pin-Hair
14	100-7338	4	Clevis
15	104-3634	4	Pin-Clevis
16	3220-5	4	Nut-Jam
17	104-8047	4	Rod-Trunion
18	1-800805	1	Screw-HH
19	104-8037-01	1	Plate-Bolt, Retainer
20	104-3699-01	2	Link-HOC, Adjusting
21	3256-26	12	Washer-Flat
22	3296-16	2	Nut-Lock, NI
23	46-6290	1	O-Ring

Ref	Part No.	Qty.	Description
24	3256-1	2	Washer-Flat
25	95-2747	1	Fitting-Washout
26	3229-1	2	Screw-CARR
27	95-3270	1	Connector-Hose
28	3272-10	4	Pin-Cotter
29	302-19	1	Fitting-Grease



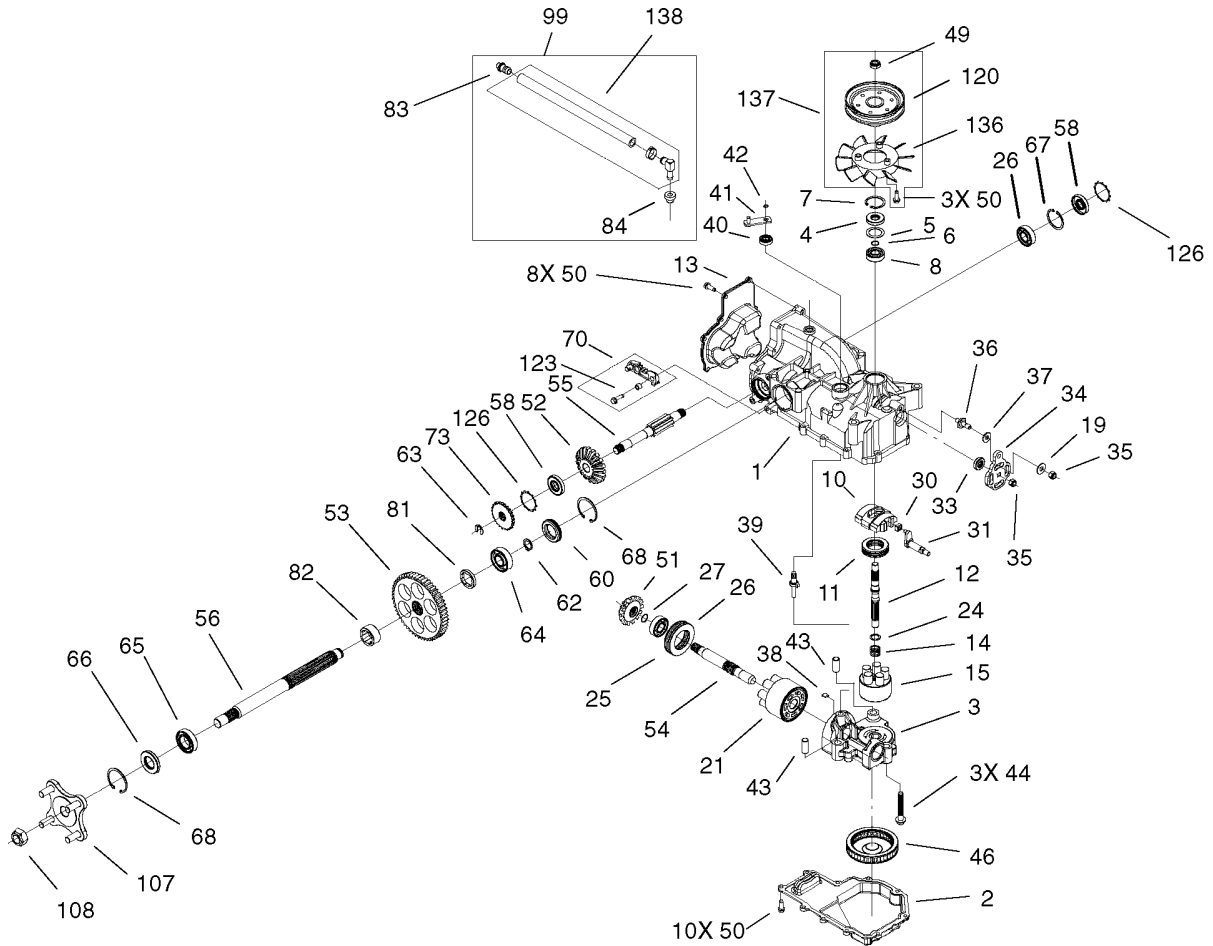

## Right Hand Hydro Transaxle Assembly No. 100-7360

Ref	Part No.	Qty.	Description
1	105-1867	1	Main Housing Kit
2	105-1868	1	Housing-Lower
3	105-1869	1	Center Section Kit ASM
4	92-6543	1	Seal-Lip
5	104-2104	1	Spacer
6	94-1902	1	Ring-Wire, Retaining
7	94-1903	1	Ring-Retaining
8	94-1904	1	Bearing-Shaft, Ball
10	94-1907	1	Swashplate-Variable
11	94-6922	1	Bearing-Thrust
12	104-5067	1	Shaft-Input
13	105-1870	1	Cover-Back
14	94-1936	1	Spring-Block
15	104-2106	1	Cylinder Block ASM
19	104-2146	1	Washer
21	94-1913	1	Cylinder Block ASM
24	94-1937	1	Washer-Thrust, Block
25	94-6923	1	Bearing-Thrust
26	104-5311	2	Bearing-Ball
27	104-5307	1	Ring-Retaining
30	94-1910	1	Guide-Slot
31	104-2112	1	Trunnion ASM
33	92-6544	1	Seal-Lip
34	105-1871	1	Arm-Control

Ref	Part No.	Qty.	Description
35	105-1872	2	Nut
36	104-2116	1	Stud
37	105-1873	1	Puck-Friction
38	94-6925	1	Plate-Bypass
39	94-1914	1	Actuator-Bypass
40	92-6545	1	Seal-Lip
41	104-2117	1	Arm-Bypass
42	936109	1	Ring-Retaining
43	94-1927	2	Pin
44	94-6926	3	Bolt
46	105-1874	1	Filter
49	105-1875	1	Nut-Lock
50	104-2120	21	Screw
51	105-1876	1	Gear-Bevel, 14T
52	105-1877	1	Gear-Bevel, 19T
53	105-1878	1	Gear-Bevel, 53T
54	105-1879	1	Shaft-Motor
55	105-1880	1	Shaft-Brake
56	105-1881	1	Shaft-Axle
58	104-5310	2	Seal-Lip
60	105-1882	1	Plug-Side Seal
62	105-1883	1	Ring-Axle, Retaining
63	105-1884	1	Ring-Retaining
64	105-1885	1	Bearing-Ball



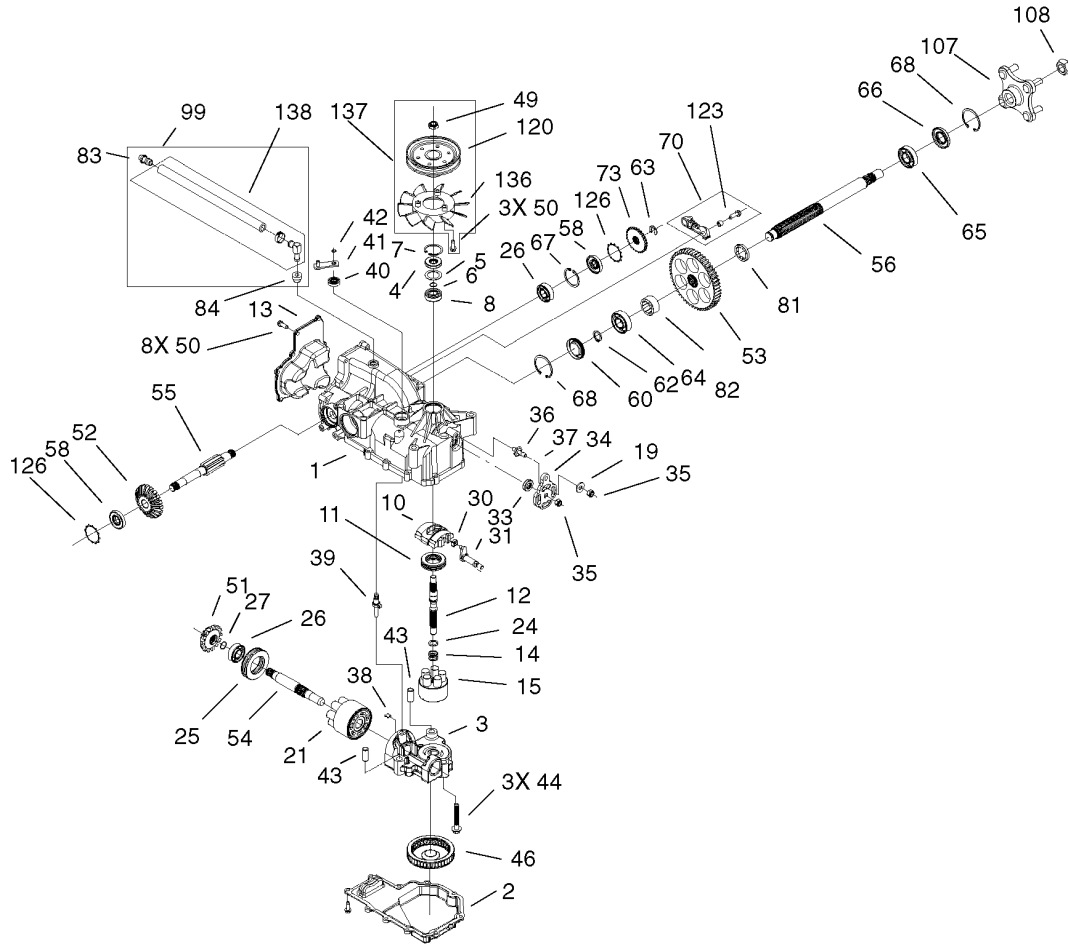

## Left Hand Hydro Transaxle Assembly No. 100-7361

Ref	Part No.	Qty.	Description
1	105-1867	1	Main Housing Kit
2	105-1868	1	Housing-Lower
3	105-1869	1	Center Section Kit ASM
4	92-6543	1	Seal-Lip
5	104-2104	1	Spacer
6	94-1902	1	Ring-Wire, Retaining
7	94-1903	1	Ring-Retaining
8	94-1904	1	Bearing-Shaft, Ball
10	94-1907	1	Swashplate-Variable
11	94-6922	1	Bearing-Thrust
12	104-5067	1	Shaft-Input
13	105-1870	1	Cover-Back
14	94-1936	1	Spring-Block
15	104-2106	1	Cylinder Block ASM
19	104-2146	1	Washer
21	94-1913	1	Cylinder Block ASM
24	94-1937	1	Washer-Thrust, Block
25	94-6923	1	Bearing-Thrust
26	104-5311	2	Bearing-Ball
27	104-5307	1	Ring-Retaining
30	94-1910	1	Guide-Slot
31	104-2112	1	Trunnion ASM
33	92-6544	1	Seal-Lip
34	105-1871	1	Arm-Control

Ref	Part No.	Qty.	Description
35	105-1872	2	Nut
36	104-2116	1	Stud
37	105-1873	1	Puck-Friction
38	94-6925	1	Plate-Bypass
39	94-1914	1	Actuator-Bypass
40	92-6545	1	Seal-Lip
41	104-2117	1	Arm-Bypass
42	936109	1	Ring-Retaining
43	94-1927	2	Pin
44	94-6926	3	Bolt
46	105-1874	1	Filter
49	105-1875	1	Nut-Lock
50	104-2120	21	Screw
51	105-1876	1	Gear-Bevel, 14T
52	105-1877	1	Gear-Bevel, 19T
53	105-1878	1	Gear-Bevel, 53T
54	105-1879	1	Shaft-Motor
55	105-1880	1	Shaft-Brake
56	105-1881	1	Shaft-Axle
58	104-5310	2	Seal-Lip
60	105-1882	1	Plug-Side Seal
62	105-1883	1	Ring-Axle, Retaining
63	105-1884	1	Ring-Retaining
64	105-1885	1	Bearing-Ball

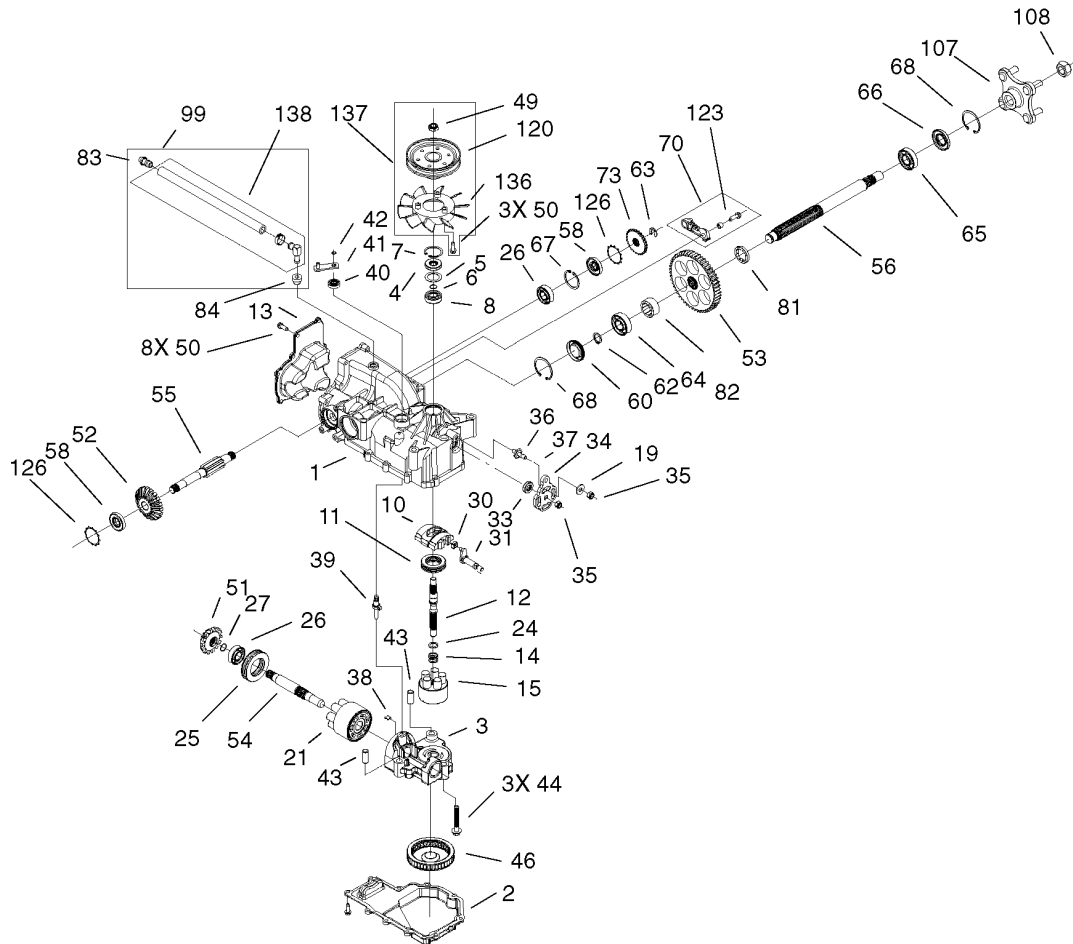

## Left Hand Hydro Transaxle Assembly No. 100-7361 (continued)

Ref	Part No.	Qty.	Description
65	105-1886	1	Bearing-Ball
66	105-1887	1	Seal
67	104-5309	1	Ring-Retaining
68	105-1888	2	Ring-Retaining, Axle
70	105-1889	1	LH Brake Arm ASM
73	105-1890	1	Disc-Brake
81	105-1891	1	Bushing-Axle
82	105-1892	1	Bushing-Axle
83	104-2167	1	Vent Cap ASM
84	104-2165	1	Bushing-Rubber
99	105-1893	1	Kit-Breather
100	104-2147	1	Sealant
107	105-1894	1	Hub ASM
108	105-1895	1	Nut
120	105-1896	1	Pulley
123	105-1897	1	Screw
126	105-1898	2	Ring-Retaining
134	105-1899	1	Seal Kit
136	105-1927	1	Fan
137	105-1928	1	Fan Pulley Kit
138	105-1929	1	Kit-Hose

--	--	--	--

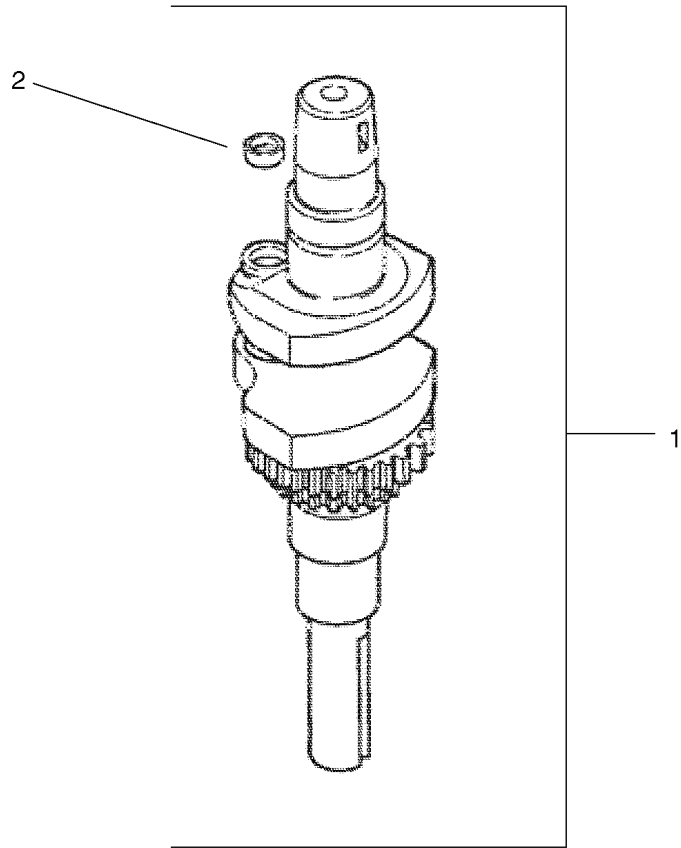

## Crankshaft Assembly Kohler CV 490-27503

Ref	Part No.	Qty.	Description
1	12 014 57-S	1	Crankshaft (Includes 2)
2	25 139 27-S	1	Plug-Cup

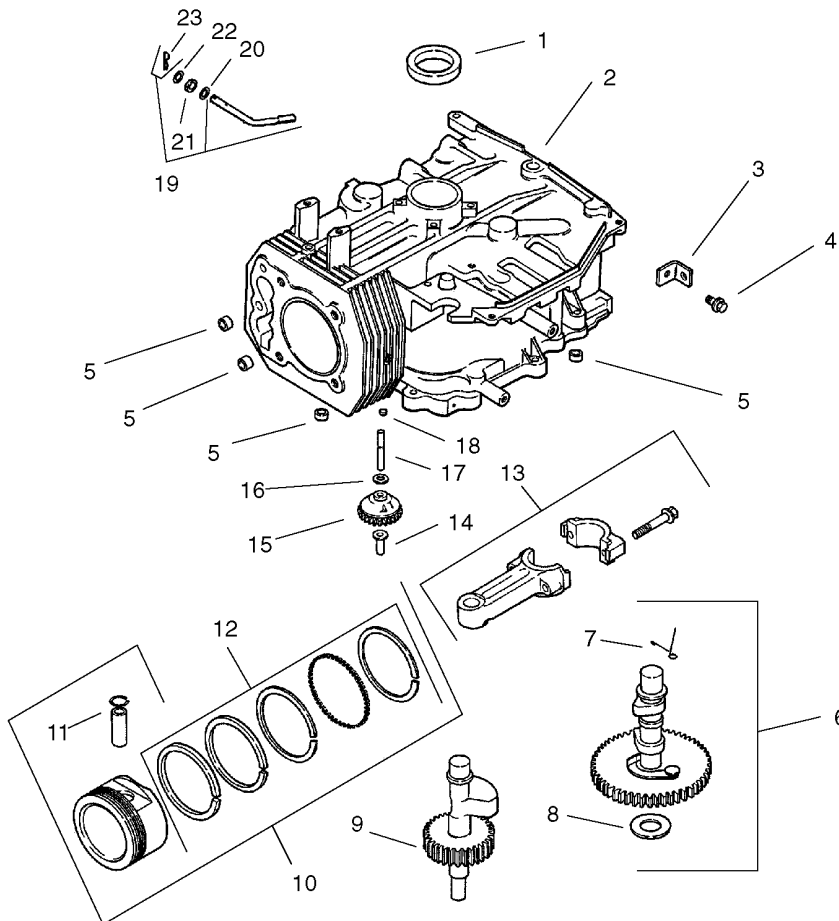

## Crankcase Assembly Kohler CV 490-27503

Ref	Part No.	Qty.	Description
1	12 032 03-S	1	Seal-Oil
2		0	Block, Cylinder (Use:short Block 12 522 51)
3	12 445 02-S	1	Strap-Lifting
4	M-839025-S	1	Screw-HF (M8X1.25X25)
5	24 380 13-S	1	Pin-Locating
6	12 755 49-S	1	Kit, Camshaft (Includes 7, 8)
7	12 089 31-S	1	Spring-Actuating
8	12 422 08-S	1	Shim-Camshaft (Blue .03)
9	12 422 09-S	1	Shim-Camshaft (Red .032)
10	12 422 10-S	1	Shim-Camshaft (Yellow .034)
11	12 422 11-S	1	Shim-Camshaft (Green .036)
12	12 422 12-S	1	Shim-Camshaft (Gray .038)
13	12 422 13-S	1	Shim-Camshaft (Black .04)
14	12 422 07-S	1	Shim-Camshaft (White .028)
15	12 144 28-S	1	Shaft-Balance
16	12 874 07-S	1	Piston W/Ring Set (STD.) (Includes 11, 12)
17	12 874 08-S	1	Piston W/Ring Set (.25)
18	12 874 09-S	1	Piston W/Ring Set (.50)
19	12 874 11-S	1	Piston W/Ring Set (.08)
20	12 018 02-S	1	Retainer-Pin, Piston
21	12 108 07-S	1	Ring Set (STD. And .08)
22	12 108 08-S	1	Ring Set (.25)

Ref	Part No.	Qty.	Description
1	12 108 09-S	1	Ring Set (.50)
13	12 067 11-S	1	Rod-Connecting (STD)
14	12 067 12-S	1	Rod-Connecting (.25)
15	12 380 01-S	1	Pin-Regulating, Governor
16	12 043 05-S	1	Gear-Governor
17	M-631005-S	1	Washer-Flat (6 Mm)
18	12 144 02-S	1	Shaft-Gear, Governor
19	52 139 09-S	1	Plug-Cup
20	12 755 64-S	1	Kit, Governor Cross Shaft W/Clip (Includes 23)
21	X-25-102-S	1	Washer-Flat (1/4)
22	12 032 01-S	1	Seal-Cross Shaft, Governor
23	M-631015-S	1	Washer-Flat (6Mm)
24	12 154 05-S	1	Clip-Pin, Hitch

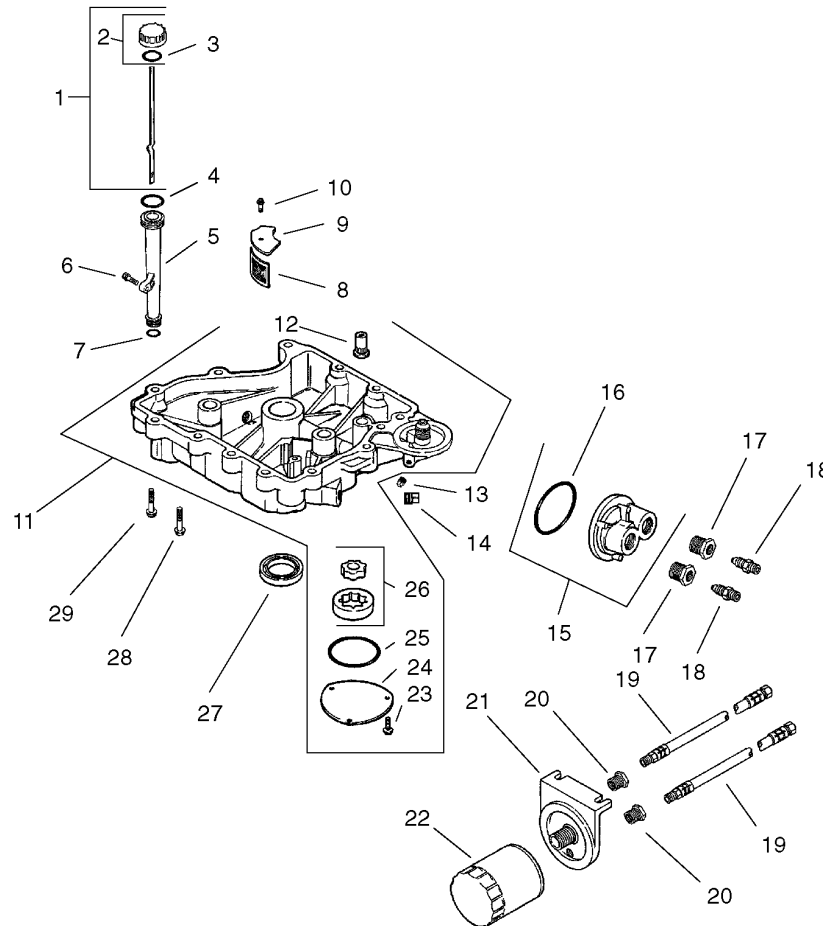

## Oil Pan / Lubrication Assembly Kohler CV 490-27503

Ref	Part No.	Qty.	Description
❶	12 038 02-S	1	Dipstick (Includes 2, 3)
❷	24 755 46-S	1	Kit, Oil Fill Cap (Includes 3)
❸	12 153 03-S	1	O-Ring
❹	12 153 02-S	1	O-Ring
❺	12 123 04-S	1	Oil Fill Tube Kit
❻	M-545020-S	1	Screw-Flange, Thread Forming (M5X0.8X20)
❼	12 153 01-S	1	O-Ring
❽	25 162 07-S	1	Screen-Pickup, Oil
❾	12 096 03-S	1	Cover-Screen, Oil Pickup
❿	M-545016-S	1	Screw-Flange, Thread Forming (M5X0.8X16)
⓫	12 199 50-S	1	Pan, Oil (Includes 12, 23-26)
⓬	25 462 09-S	1	Valve-Relief, Oil Pressure
⓭	25 139 52-S	1	Plug-Pipe (1/8In)
⓮	25 139 57-S	1	Plug-Pipe, Sq HD (3/8)
⓯	24 029 02-S	1	Adapter, Oil Filter (Includes 16)
⓰	24 153 13-S	1	O-Ring
⓱	25 158 10-S	1	Bushing, Reducing 7/8X1/4X1/2 N.P.T.F.
⓲	52 136 02-S	1	Nipple-Metallic
⓳	52 326 11-S	1	Hose, Oil (Red Tracer) (2) 1/8-27 N.P.T.F. Male Coupling, 1/4-18 N.P.S.M. Female Coupling X 23In Long

Ref	Part No.	Qty.	Description
⓴	25 158 15-S	1	Bushing, Reducing 1/8X1/4 N.P.T.F.
⓵	12 029 02-S	1	Adapter, Oil Filter
⓶	12 050 01-S	1	Filter-Oil
⓷	M-545016-S	1	Screw-Flange, Thread Forming (M5X0.8X16)
⓸	12 096 34-S	1	Cover-Pump, Oil
⓹	12 153 06-S	1	O-Ring (Oil Pump Cover)
⓺	12 393 01-S	1	Oil Pump ASM
⓻	12 032 03-S	1	Seal-Oil
⓼	24 086 16-S	1	Screw-HF (M8X1.25X45)
⓽	24 086 17-S	1	Screw-Flange (M8X1.25X45)

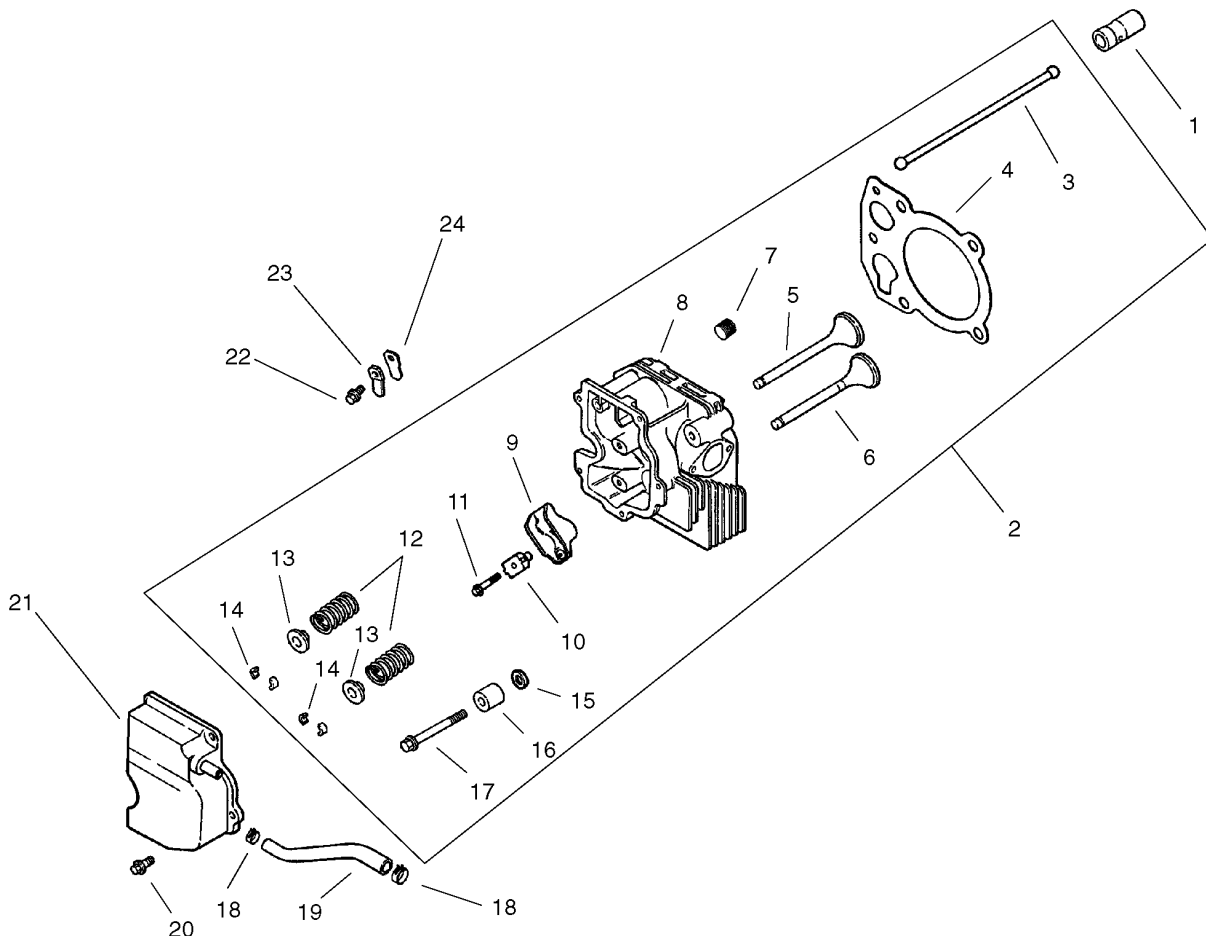

## Head / Valve / Breather Assembly Kohler CV 490-27503

Ref	Part No.	Qty.	Description
③1	25 351 01-S	1	Lifter-Valve
③	12 755 94-S	1	Kit, Cylinder Head (Includes 3-17, Carburetor Gasket (2), Air Cleaner Base Gasket, Exhaust Manifold Gasket)
③3	12 411 03-S	1	Rod-Push
③4	12 041 10-S	1	Gasket-Head, Cylinder
③5	12 017 01-S	1	Valve-Intake (STD)
③6	12 016 01-S	1	Valve-Exhaust (STD)
③7	25 139 60-S	1	Plug-Pipe, Countersunk (1/8)
③8	12 318 36-S	1	Cylinder Head
③9	25 186 01-S	1	Arm-Rocker
③10	12 599 03-S	1	Pivot-Arm, Rocker
③11	M-640034-S	1	Screw-Flange (M6X1.0X34)
③12	12 089 34-S	1	Spring-Valve
③13	12 173 01-S	1	Cap-Spring, Valve
③14	12 755 03-S	1	Retainer Kit
③15	12 468 05-S	1	Washer-Flat (1/2)
③16	12 112 13-S	1	Spacer-Head Bolt (Exhaust Port)
③17	12 086 15-S	1	Screw, M10X1.5X81
③18	25 237 14-S	1	Clamp-Hose, Spring (1/2)
③19	12 326 03-S	1	Hose-Breather
③20	M-645020-S	1	Screw-Flange, Thread Forming (M6X1.0X20)
③21	12 096 07-S	1	Cover-Valve W/Nipple

Ref	Part No.	Qty.	Description
③22	M-545010-S	1	Screw-Flange, Thread Forming (M5X.8X10)
③23	12 018 01-S	1	Retainer-Reed, Breather
③24	12 402 02-S	1	Reed-Breather
③	12 017 02-S	1	Valve-Intake (.25)
③	12 016 02-S	1	Valve-Exhaust (.25)
③	12 041 01-S	1	Gasket-Carburetor
③	12 041 02-S	1	Gasket-Base, Air Cleaner
③	12 041 03-S	1	Gasket-Manifold, Exhaust

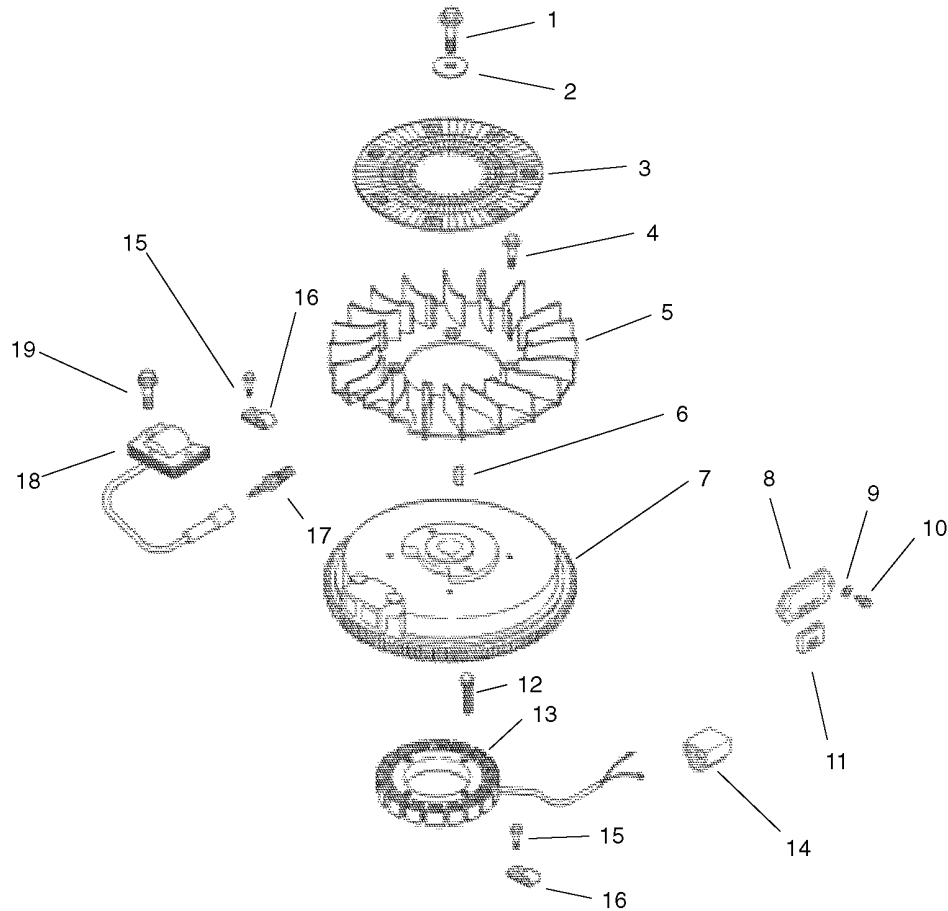

## Ignition / Electrical Assembly Kohler CV 490-27503

Ref	Part No.	Qty.	Description
❶	12 086 14-S	1	Screw-Flange (M10X1.5X45)
❷	12 468 03-S	1	Washer-Flat (13/32)
❸	24 162 03-S	1	Screen-Grass
❹	25 086 47-S	1	Bolt-Shoulder
❺	12 157 06-S	1	Fan
❻	X-42-15-S	1	Key (3/16 X 5/8)
❼	12 025 15-S	1	Flywheel
❽	41 403 09-S	1	Rectifier-Regulator
❾	X-22-11-S	1	Washer-Lock, Internal Tooth (1/4)
❿	M-639016-S	1	Screw-HF (M6X1.0X16)
⓫	236602-S	1	Connector (3 Contact)
⓬	M-548025-S	1	Screw-Thread Forming (M5X0.8X25)
⓭	237878-S	1	Kit, Stator (Includes Terminal 25 452 01-S)
⓮	48 155 01-S	1	Connector (5 Contact)
⓯	M-545010-S	1	Screw-Flange, Thread Forming (M5X.8X10)
⓰	X-728-1-S	1	Clip
⓱	12 132 02-S	1	Plug-Spark
⓲	12 584 04-S	1	Module-Ignition
⓳	M-545020-S	1	Screw-Flange, Thread Forming (M5X.8X20)
⓴	25 518 05-S	1	Lead
⓵	12 518 01-S	1	Lead

Ref	Part No.	Qty.	Description
⓶	24 518 12-S	1	Lead-Black



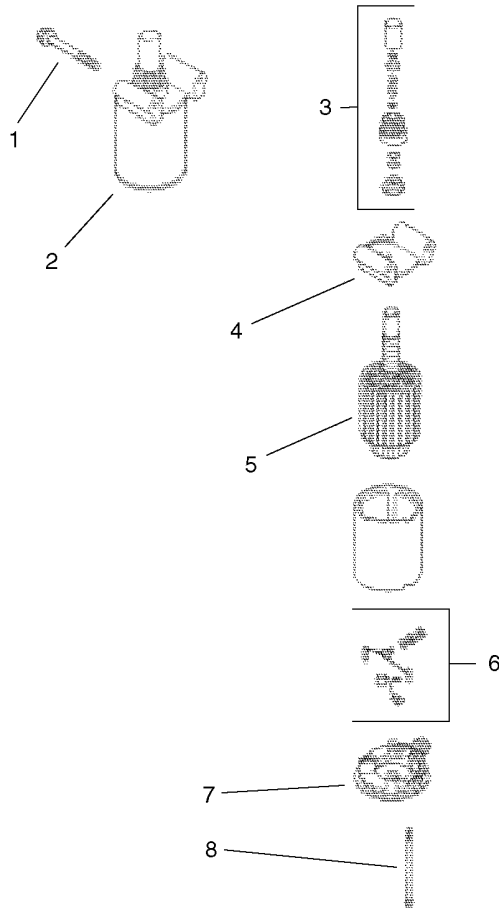

## Starting System Assembly Kohler CV 490-27503

Ref	Part No.	Qty.	Description
❶	M-839070-S	1	Screw-HF (M8X1.25X70)
❷	12 098 15-S	1	Starter Assembly (Includes 3-8)
❸	12 755 53-S	1	Drive Kit
❹	12 227 19-S	1	Cap-End, Drive
❺	12 170 05-S	1	Armature
❻	12 221 01-S	1	Brush ASM
❼	12 227 13-S	1	Commutator-Cap, End
❽	12 211 01-S	1	Bolt

--	--	--	--

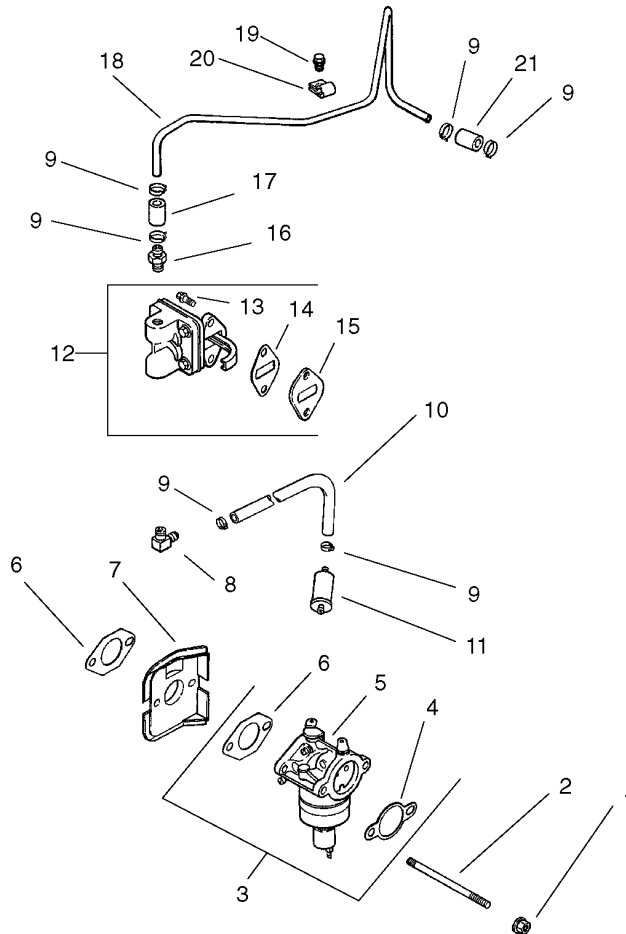

## Fuel System Assembly Kohler CV 490-27503

Ref	Part No.	Qty.	Description
❶	M-641060-S	1	Nut-Flange (M6X1.0)
❷	M-629116-S	1	Stud (M6X1.0X116)
❸	12 853 117-S	1	Kit, Carburetor W/Gaskets (Includes 4, 5, 6 Qty. 1, Tie 12 454 03-S And Terminal 25 452 20- S)
❹	12 041 02-S	1	Gasket-Base, Air Cleaner
❺	12 053 117	1	Carburetor Assembly (For Information Only Not Available Separately)(Service With Kits: 12 757 02-S, 12 757 03-S, 12 757 33-S)
❻	12 041 01-S	1	Gasket-Carburetor
❼	12 265 06-S	1	Deflector-Heat
❽	25 155 02-S	1	Connector-Hose, 90 DEG
❾	25 237 14-S	1	Clamp-Hose, Spring (1/2)
❿	25 353 14-S	1	Line-Fuel, 7 Inch
⓫	25 050 02-S	1	Filter-Fuel
⓬	12 559 01-S	1	Kit, Fuel Pump (Includes 13-15)
⓭	M-645020-S	1	Screw-Flange, Thread Forming (M6X1.0X20)
⓮	25 041 09-S	1	Gasket-Pump, Fuel
⓯	12 112 05-S	1	Spacer-Pump, Fuel
⓰	25 326 03-S	1	Connector-Hose, Straight
⓱	12 353 01-S	1	Line-Fuel (1-1/4In)
⓲	12 123 19-S	1	Line-Fuel. Metal

Ref	Part No.	Qty.	Description
❸	M-545010-S	1	Screw-Flange, Thread Forming (M5X.8X10)
❹	12 154 01-S	1	Clamp-Insulated
❺	41 353 18-S	1	Line-Fuel (2-1/2In)
❻	12 757 02-S	1	Float Repair Kit
❼	12 757 03-S	1	Carburetor Repair Kit
❽	12 757 33-S	1	Solenoid Repair Kit
❾	12 518 24-S	1	Lead-Red (20In-18 Gauge- Insulated Socket And Uninsulated Push On Tab Terminals)
❿	12 454 03-S	1	Tie-Wire
⓫	M-561010-S	1	Screw-HWHTF (M5X0.8X10)
⓬	X-22-11-S	1	Washer-Lock, Internal Tooth (1/4)



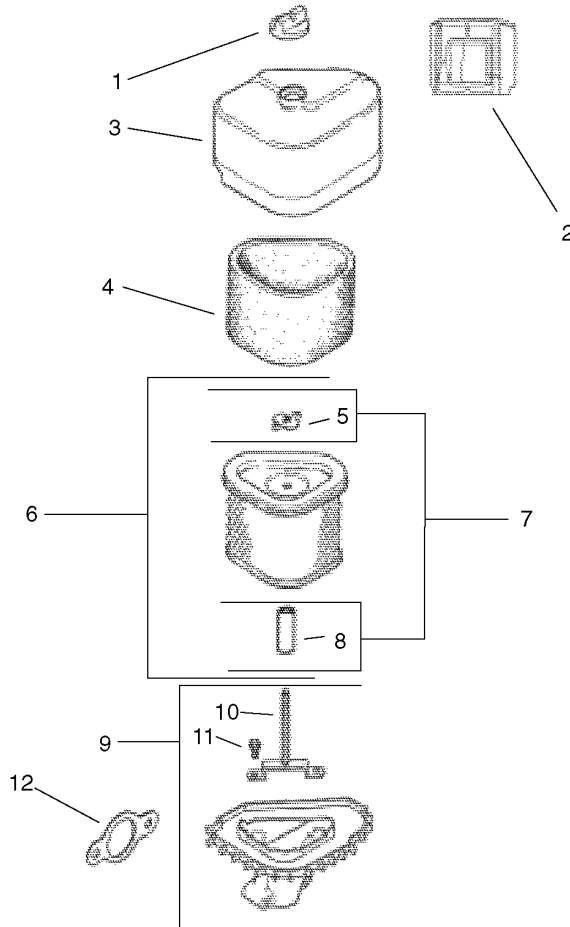

## Air Intake / Filtration Assembly Kohler CV 490-27503

Ref	Part No.	Qty.	Description				
❶	25 341 03-S	1	Knob-Cover				
❷	12 281 01-S	1	Duct, Air				
❸	12 096 24-S	1	Cover-Air Cleaner				
❹	12 083 12-S	1	Element-Precleaner				
❺	12 100 08-S	1	Nut-Wing				
❻	12 083 10-S	1	Element, Air Cleaner (Includes 5, 7, 8)				
❼	12 743 12-S	1	Kit, Air Cleaner Seal (Includes 5, 8)				
❽	12 032 11-S	1	Seal				
❾	12 094 07-S	1	Base, Air Cleaner (Includes 10, 11)				
❿	12 072 04-S	1	Stud				
⓫	12 086 01-S	1	Screw				
⓬	12 041 02-S	0	Gasket-Base, Air Cleaner				

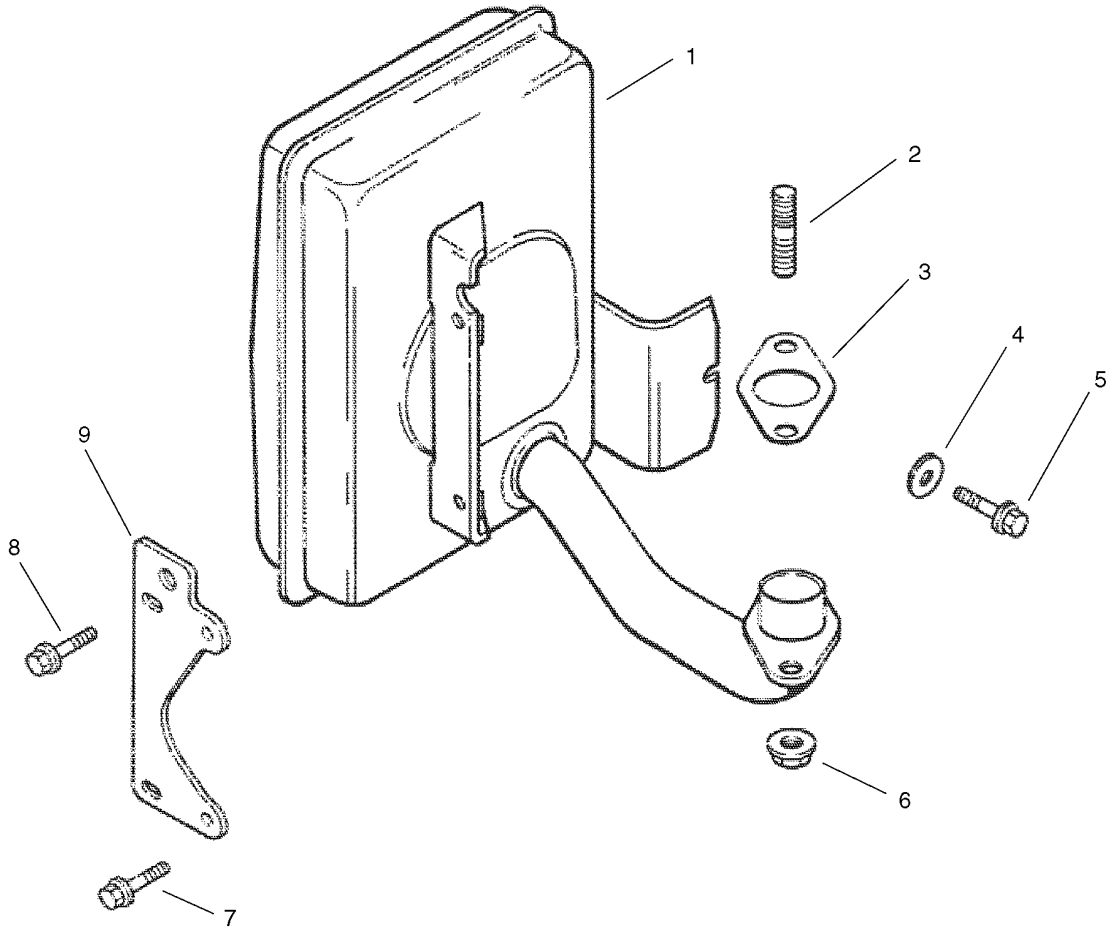

## Exhaust Assembly Kohler CV 490-27503

Ref	Part No.	Qty.	Description
❶	12 068 55-S	1	Muffler
❷	25 072 04-S	1	Stud (M8X1.25X33)
❸	12 041 03-S	1	Gasket-Manifold, Exhaust
❹	X-25-78-S	1	Washer-Plain (1/4In)
❺	M-545016-S	1	Screw-Flange, Thread Forming (M5X0.8X16)
❻	M-841080-S	1	Nut-Flange (M8X1.25)
❼	M-645016-S	1	Screw-Flange, Thread Forming (M6X1.0X16)
❽	M-645025-S	1	Screw-Flange, Thread Forming (M6X1.0X25)
❾	12 126 71-S	1	Bracket-Muffler
❿	12 755 70-S	1	Kit, Muffler Guard (Includes Screw (4) M-545010-S)
⓫	M-545010-S	1	Screw-Flange, Thread Forming (M5X.8X10)
⓬	12 522 51	1	Short Block
⓭	12 755 93-S	1	Gasket Set

--	--	--	--

## NOTES

# NOTES

