



Bio-Diesel Kit

2006 and Before Kubota®-Powered Z Master® Riding Mowers

Model No. 115-3564

Installation Instructions

This kit is for machines with a serial number of 269999999 and Below.

After this kit is installed, this machine can use a biodiesel blended fuel of up to B20 (20% biodiesel, 80% petrodiesel). The petrodiesel portion should be low or ultra low sulfur. Refer to the Operation Section for fuel precautions.



Fuel is harmful or fatal if swallowed. Long-term exposure to vapors can cause serious injury and illness.

- Avoid prolonged breathing of vapors.
- Keep face away from nozzle and gas tank or conditioner opening.
- Keep fuel away from eyes and skin.



In certain conditions, fuel is extremely flammable and highly explosive. A fire or explosion from fuel can burn you and others and can damage property.

- Wipe up any fuel that spills.
- Never fill the fuel tank inside an enclosed trailer.
- Never smoke when handling fuel, and stay away from an open flame or where fuel fumes may be ignited by a spark.

Loose Parts

Use the chart below to verify that all parts have been shipped.

| Procedure | Description | Qty. | Use |
|-----------|---|---------------------------------|---|
| 1 | Fuel selector valve with hoses | 1 | Install the new fuel selector valve. |
| 2 | Template (located in the back of these instructions) | 1 | Drill holes for the water separator and fuel pump brackets. |
| 3 | Small R-clamp Bolt (1/4 x 1-1/4 inches) Locknut (1/4 inch) Large R-clamp Bolt (5/16 x 1-3/4 inches) Bolt (5/16 x 3/4 inch) Locknut (5/16 inch) Water separator | 1 1 1 1 1 2 1 | Install the water separator and fuel pump. |
| 4 | Hose Hose clamp Fuel pump harness | 1 8 1 | Connect the fuel hoses and the fuel pump harness. |
| 5 | Low sulfur decal Fuel cap Diesel decal | 2 2 1 | Install the decals and fuel caps. |
| 6 | No parts required | – | Verify the connections. |

1

Installing the New Fuel Selector Valve

Parts needed for this procedure:

| | |
|---|--------------------------------|
| 1 | Fuel selector valve with hoses |
|---|--------------------------------|

Procedure

Important: Allow the engine to cool before installing this kit.

1. Drive the machine to a well ventilated area away from an open flame or where fuel fumes may be ignited by a spark.
2. Disengage the power take off (PTO) and set the parking brake.
3. Turn off the engine, remove the key, and wait for all moving parts to stop before leaving the operating position.
4. Disconnect the negative battery cable from the battery.
5. Close the fuel selector valve.
6. Allow the engine to cool before installing this kit.
7. Tilt the seat forward and remove the front engine panel (Figure 1).

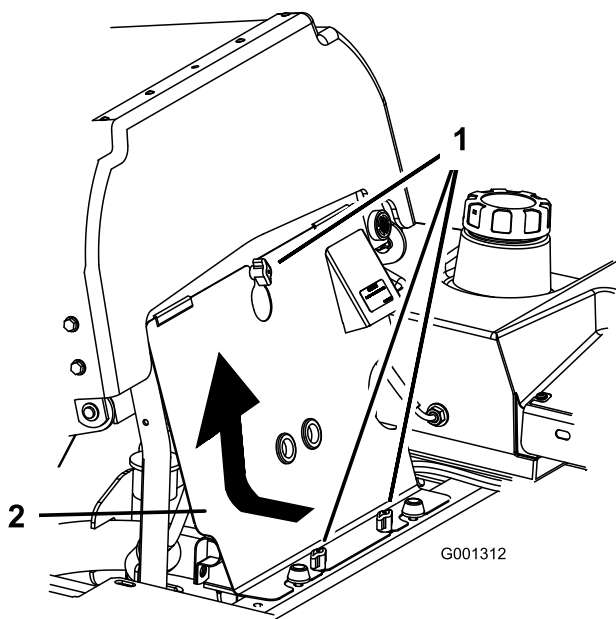

Figure 1

1. Knob
2. Front engine panel

8. To drain the fuel tank, place a clean container under the front fuel tank connection, remove the fuel hose from the connection or cut the fuel line and direct the fuel line into the container (Figure 2).
9. Allow the fuel to drain into the container and wipe up any spilled fuel. Ensure the fuel line is removed from the tank connection (Figure 2).
10. Drain the fuel from the opposite tank.

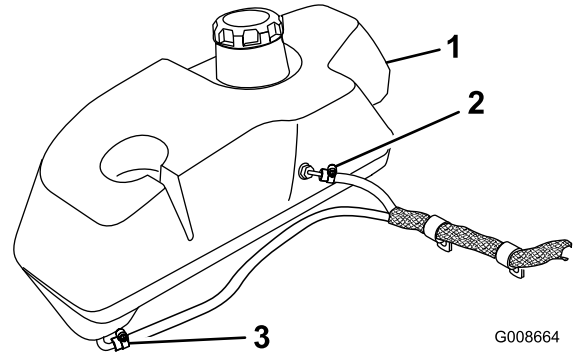

Figure 2

1. Right hand fuel tank
2. Rear fuel tank connection
3. Front fuel tank connection shown

11. Follow the fuel hoses from the existing selector valve and remove the hoses from the fuel filter and the fuel tanks.
12. Disconnect the electrical connection for the fuel pump from the main wire harness. Remember the location of this connection because it will be used for the new fuel pump.
13. Remove the existing fuel hose from the engine and remove the existing fuel filters from the machine (Figure 3).

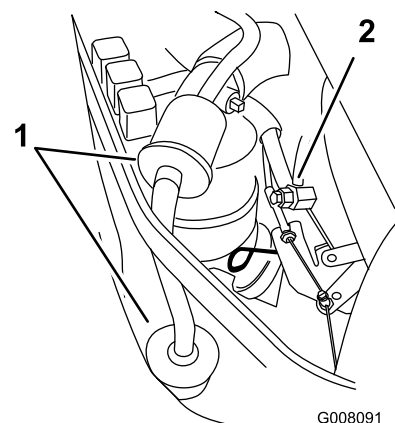

Figure 3

1. Existing fuel filters
2. Fuel hose connected to engine

14. Remove the existing fuel selector valve. Refer to Figure 4. Save the existing software.

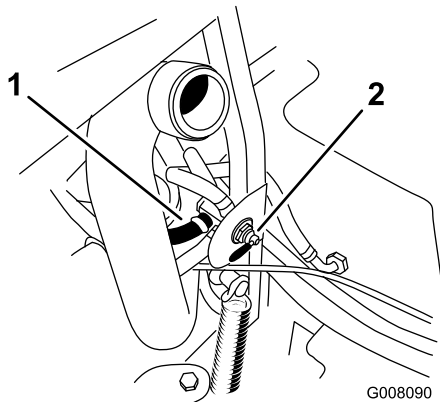
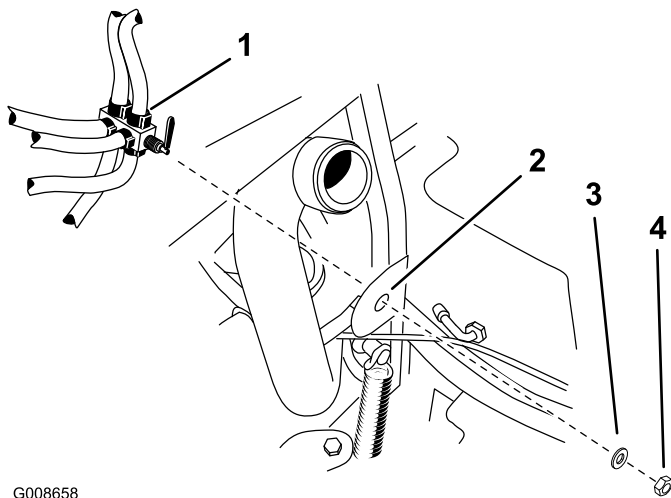

Figure 4

1. Hose to remove
2. Close fuel selector valve

15. Using the previously removed hardware, install the new fuel selector valve (Figure 5).



G008658

Figure 5

1. New fuel selector valve
2. Bracket
3. Existing washer
4. Existing nut

2. Remove the nuts and bolts holding the hood support bracket. Save the nuts and bolts (Figure 6).
3. Remove the bolt for the top engine guard strap from the machine (Figure 6).

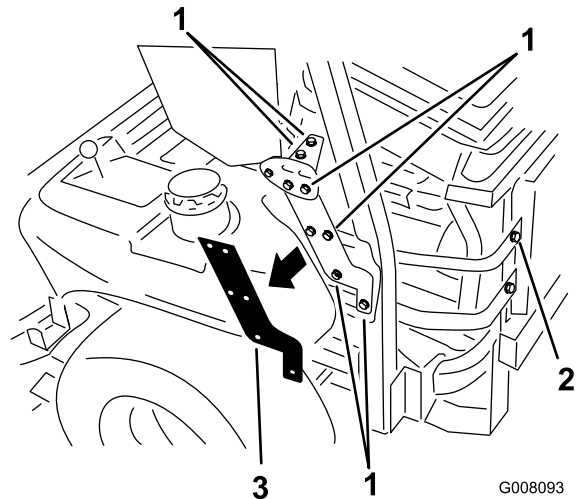

G008093

Figure 6

1. Remove these nuts and bolts from the hood support bracket
2. Remove this bolt from the top engine guard strap
3. Hood side plate bolts

4. Using the paper template in the back of these instructions, mark and drill 2 holes (11/32 inch diameter) into the hood support bracket (Figure 7).
5. Drill a 17/64 inch diameter hole into the existing hole in the engine guard strap (Figure 7).

2

Drilling Holes for the Water Separator and the Fuel Pump Brackets

Parts needed for this procedure:

| | |
|---|--|
| 1 | Template (located in the back of these instructions) |
|---|--|

Procedure

1. Raise the hood on the engine.

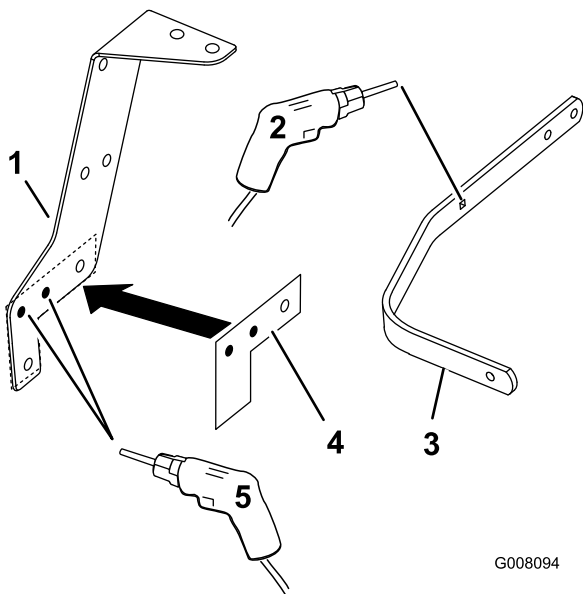

Figure 7

1. Hood side plate
2. Drill a 17/64 inch hole into the existing hole
3. Engine strap
4. Template
5. Drill two 11/32 inch holes into the hood support bracket here

2. Install the small R-clamp around the fuel pump and install it to the engine strap with a bolt (1/4 x 1-1/4 inches) and nut (1/4 inch) (Figure 8).

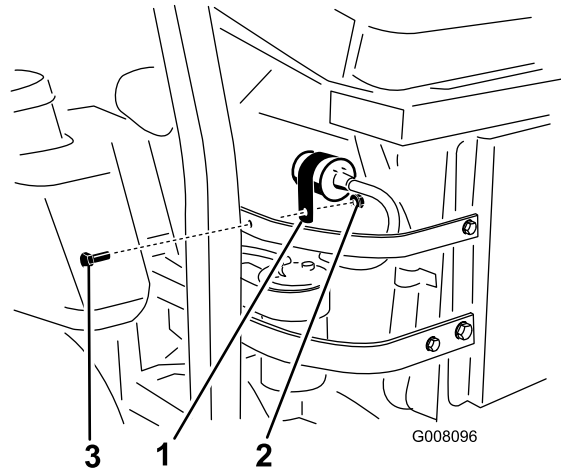

Figure 8

1. Small R-clamp with fuel pump installed
2. Locknut (1/4 inch)
3. Bolt (1/4 x 1-1/4 inches)

6. Install the engine guard strap to the back of the machine.
7. Install the hood support bracket with the previously removed nuts and bolts.

3

Installing the Water Separator and Fuel Pump

Parts needed for this procedure:

| | |
|---|----------------------------|
| 1 | Small R-clamp |
| 1 | Bolt (1/4 x 1-1/4 inches) |
| 1 | Locknut (1/4 inch) |
| 1 | Large R-clamp |
| 1 | Bolt (5/16 x 1-3/4 inches) |
| 1 | Bolt (5/16 x 3/4 inch) |
| 2 | Locknut (5/16 inch) |
| 1 | Water separator |

Procedure

1. Route the fuel filter and fuel pump towards the back of the engine. Make sure no parts or hoses are touching the machine in areas that will get hot.

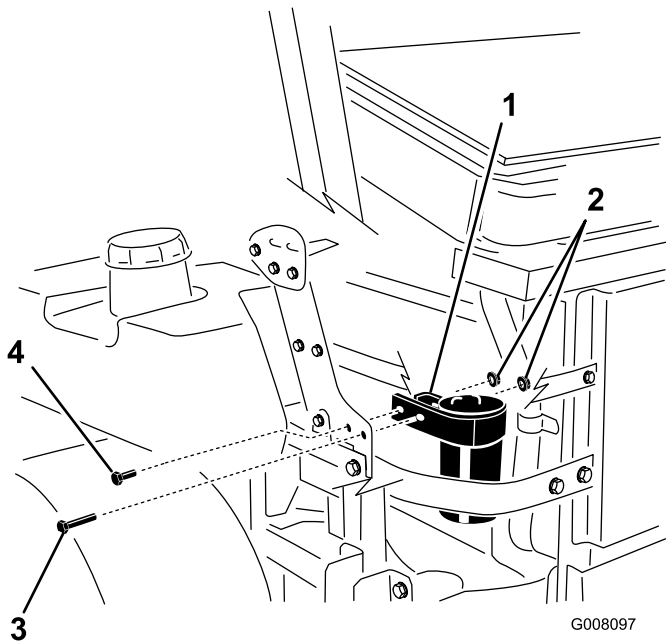

Figure 9

1. Large R-clamp with water separator
2. Locknut (1/4 inch)
3. Bolt (5/16 x 1-3/4 inches)
4. Bolt (5/16 x 3/4 inch)

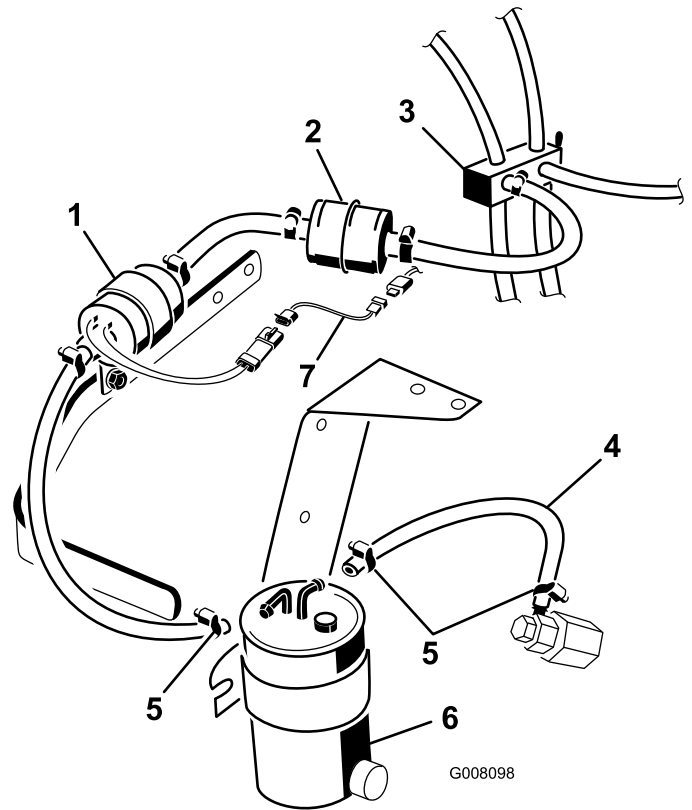

Figure 10

1. Fuel pump
2. Fuel filter
3. Valve selector
4. Hose
5. Hose clamp
6. Water separator
7. Fuel pump harness

4

Connecting the Fuel Hoses and the Fuel Pump Harness

Parts needed for this procedure:

| | |
|---|-------------------|
| 1 | Hose |
| 8 | Hose clamp |
| 1 | Fuel pump harness |

Procedure

1. Install the hose installed on the fuel pump to the water separator with a hose clamp. See Figure 10 for the correct connection to use on the top of the water separator.
2. Install the hose to the water separator and to the engine fuel intake with 2 hose clamps (Figure 10).
3. Install the electrical fuel pump wire to the fuel pump harness.
4. Install the fuel pump harness to the main wire harness (Figure 10).

5. Install the fabric sleeve on the right hand tank hoses. See Figure 11 for the correct hoses.
6. Install the hoses with the fabric sleeve into the two R-clamps (Figure 11).
7. Install the longer hose to the front right hand fuel tank connection (Figure 11).
8. Install the short hose to the back right hand fuel tank connection (Figure 11).

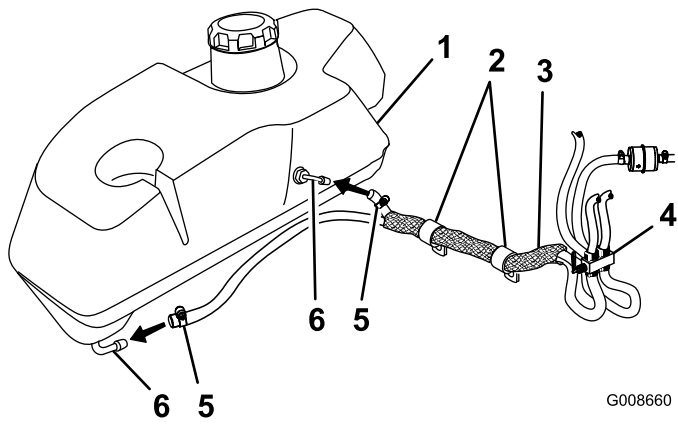

Figure 11

G008660

- 1. Right hand fuel tank
- 2. R-clamp
- 3. Fabric sleeve
- 4. Fuel selector valve
- 5. Hose clamp
- 6. Fuel tank connection

5

Installing the Decals and Fuel Caps

Parts needed for this procedure:

| | |
|---|------------------|
| 2 | Low sulfur decal |
| 2 | Fuel cap |
| 1 | Diesel decal |

Procedure

1. Lower the engine hood.
2. Remove the existing decal on each side.
3. Install a low sulfur decal on each side of the engine hood. See Figure 13 for the correct position.

9. Install the longer fuel hose to the front left hand fuel tank connection. See Figure 12. for the correct hoses.
10. Install the short hose to the back left hand fuel tank connection (Figure 12).

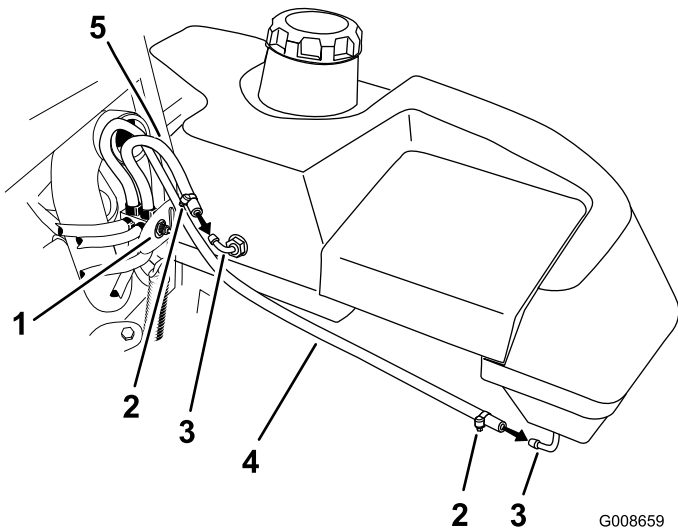

Figure 12

G008659

- 1. Fuel selector valve
- 2. Hose clamp
- 3. Fuel tank connection
- 4. Long fuel hose
- 5. Short fuel hose

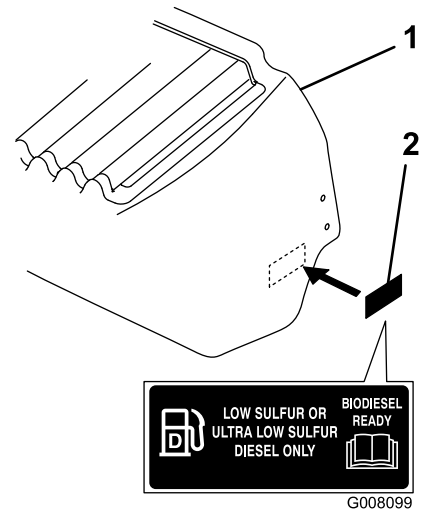

Figure 13

G008099

- 1. Engine hood
- 2. Low sulfur decal

4. Clean the existing front decal and the area around it and let it dry (Figure 14).
5. Install the new diesel decal over the existing one. See Figure 14.

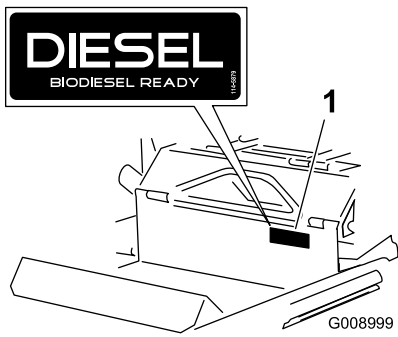

Figure 14

1. Diesel decal

6. Remove both existing fuel caps and replace them with the new fuel caps (Figure 15).

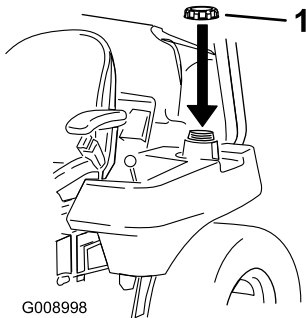

Figure 15

1. New fuel cap

6

Verifying the Connections

No Parts Required

Procedure

1. Open the fuel selector valve.
2. Open the water separator drain valve until fuel starts to drain out and close the valve (Figure 16).
3. Ensure there are no leaks at the fuel hose connections.
4. Install the negative battery onto the battery.
5. Start the engine and ensure there are no leaks.

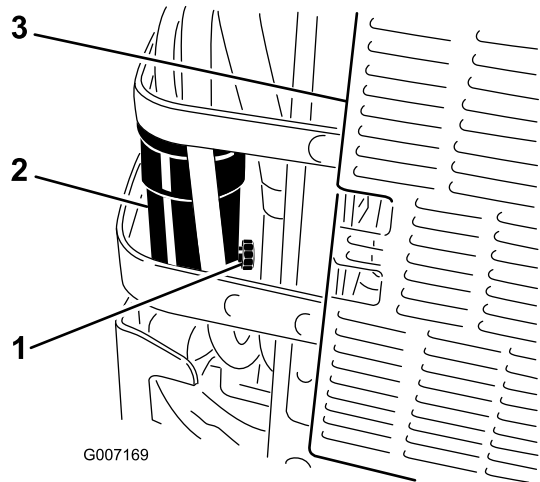

Figure 16

1. Drain valve
2. Water separator
3. Back of machine

Operation

Adding Fuel

After this kit is installed, this machine can use a biodiesel blended fuel of up to B20 (20% biodiesel, 80% petrodiesel). The petrodiesel portion should be low or ultra low sulfur.

Observe the following precautions:

- The biodiesel portion of the fuel meet specification ASTM D6751 or EN14214.
- The blended fuel composition should meet ASTM D975 or EN590.
- Painted surfaces may be damaged by biodiesel blends.
- Use B5 (biodiesel content of 5%) or lesser blend in cold weather.
- Monitor seals, hoses, gaskets in contact with fuel as they may be degrade over time.
- Fuel filter plugging maybe expected for a time after converting to biodiesel blends.
- Contact your distributor if you wish for more information on biodiesel.

Purchase fuel in quantities that can be used within 30 days to ensure fuel freshness.

Use summer grade diesel fuel (No. 2-D) at temperatures above 20° F (-7° C) and winter grade diesel fuel (No. 1-D or No. 1-D/2-D blend) below 20° F (-7° C). Use of winter grade diesel fuel at lower temperatures provides lower flash point and pour point characteristics, therefore easing startability and lessening chances of chemical separation of the fuel due to lower temperatures (wax appearance, which may plug filters).

Use of summer grade diesel fuel above 20° F (-7° C) will contribute toward longer life of the pump components.

Important: Do not use kerosene or gasoline instead of diesel fuel. Failure to observe this caution will damage the engine.



In certain conditions, fuel is extremely flammable and highly explosive. A fire or explosion from fuel can burn you and others and can damage property.

- Fill the fuel tank outdoors, in an open area, when the engine is cold. Wipe up any fuel that spills.
- Never fill the fuel tank inside an enclosed trailer.
- Do not fill the fuel tank completely full. Add fuel to the fuel tank until the level is 1/4 to 1/2 inch (6 to 13 mm) below the bottom of the filler neck. This empty space in the tank allows fuel to expand.
- Never smoke when handling fuel, and stay away from an open flame or where fuel fumes may be ignited by a spark.
- Store fuel in an approved container and keep it out of the reach of children. Never buy more than a 30-day supply of fuel.
- Always place fuel containers on the ground away from your vehicle before filling.
- Do not fill fuel containers inside a vehicle or on a truck or trailer bed because interior carpets or plastic truck bed liners may insulate the container and slow the loss of any static charge.
- When practical, remove gas-powered equipment from the truck or trailer and refuel the equipment with its wheels on the ground.
- If this is not possible, then refuel such equipment on a truck or trailer from a portable container, rather than from a fuel dispenser nozzle.
- If a fuel dispenser nozzle must be used, keep the nozzle in contact with the rim of the fuel tank or container opening at all times until fueling is complete.



Fuel is harmful or fatal if swallowed. Long-term exposure to vapors can cause serious injury and illness.

- **Avoid prolonged breathing of vapors.**
- **Keep face away from nozzle and gas tank or conditioner opening.**
- **Keep gas away from eyes and skin.**

Filling the Fuel Tank

1. Shut the engine off and set the parking brake.
2. Clean around each fuel tank cap and remove the cap. Add fuel to both fuel tanks, until the level is 1/4 to 1/2 inch (6 to 13 mm) below the bottom of the filler neck. This space in the tank allows the fuel to expand. Do not fill the fuel tanks completely full.
3. Install fuel tank caps securely. Wipe up any fuel that may have spilled.
4. If possible, fill the fuel tank after each use. This will minimize possible buildup of condensation inside the fuel tank.

Maintenance

Servicing the Fuel Filter and Water Separator

Service Interval: Every 40 hours—Drain the water separator.

Every 400 hours/Yearly (whichever comes first)—Replace the fuel filter (more often in dirty or dusty conditions).

Draining the Water Separator

1. Position the machine on a level surface.
2. Disengage the PTO, move the motion control levers to the neutral locked position and set the parking brake.
3. Stop the engine, remove the key, and wait for all moving parts to stop before leaving the operating position.
4. Locate the water separator at the back left of the machine.
5. Place a drain pan below the water separator.
6. Open the drain valve on the water separator approximately one turn to allow water and other contaminants to drain (Figure 17).
7. Close the drain valve when only diesel fuel comes out (Figure 17).

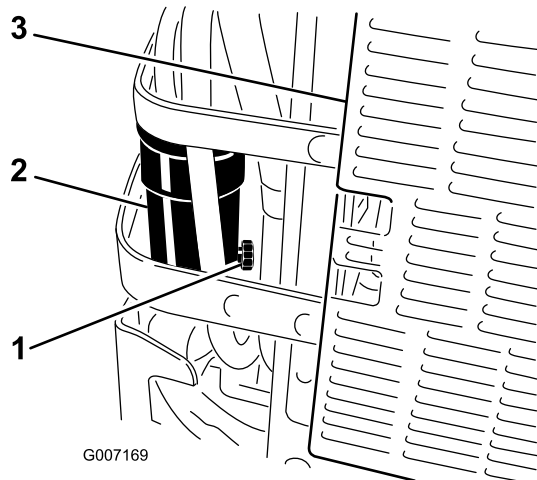

Figure 17

- | | |
|--------------------|--------------------|
| 1. Drain valve | 3. Back of machine |
| 2. Water separator | |

Changing the Fuel Filter

Never install a dirty fuel filter if it is removed from the fuel line.

1. Allow the machine to cool down.
2. Disengage the PTO, move the motion control levers to the neutral locked position and set the parking brake.
3. Stop the engine, remove the key, and wait for all moving parts to stop before leaving the operating position.
4. Close the fuel shut-off valve (Figure 18).
5. Loosen the two hose clamps and disconnect the fuel lines from the fuel filter (Figure 18).
6. Install a new filter. Connect the fuel lines to the fuel filter and install the two hose clamps (Figure 18).
7. Open the fuel shut-off valve.
8. Start the engine and check for leaks.

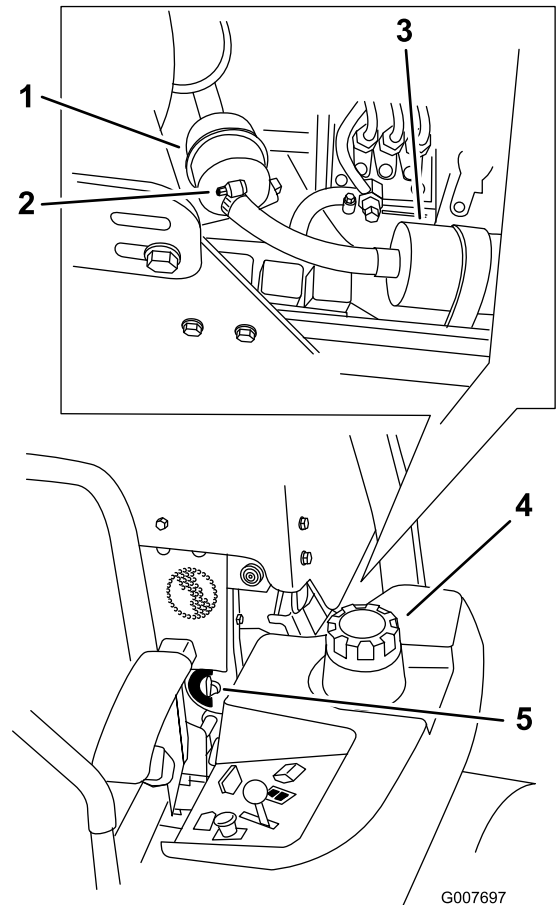
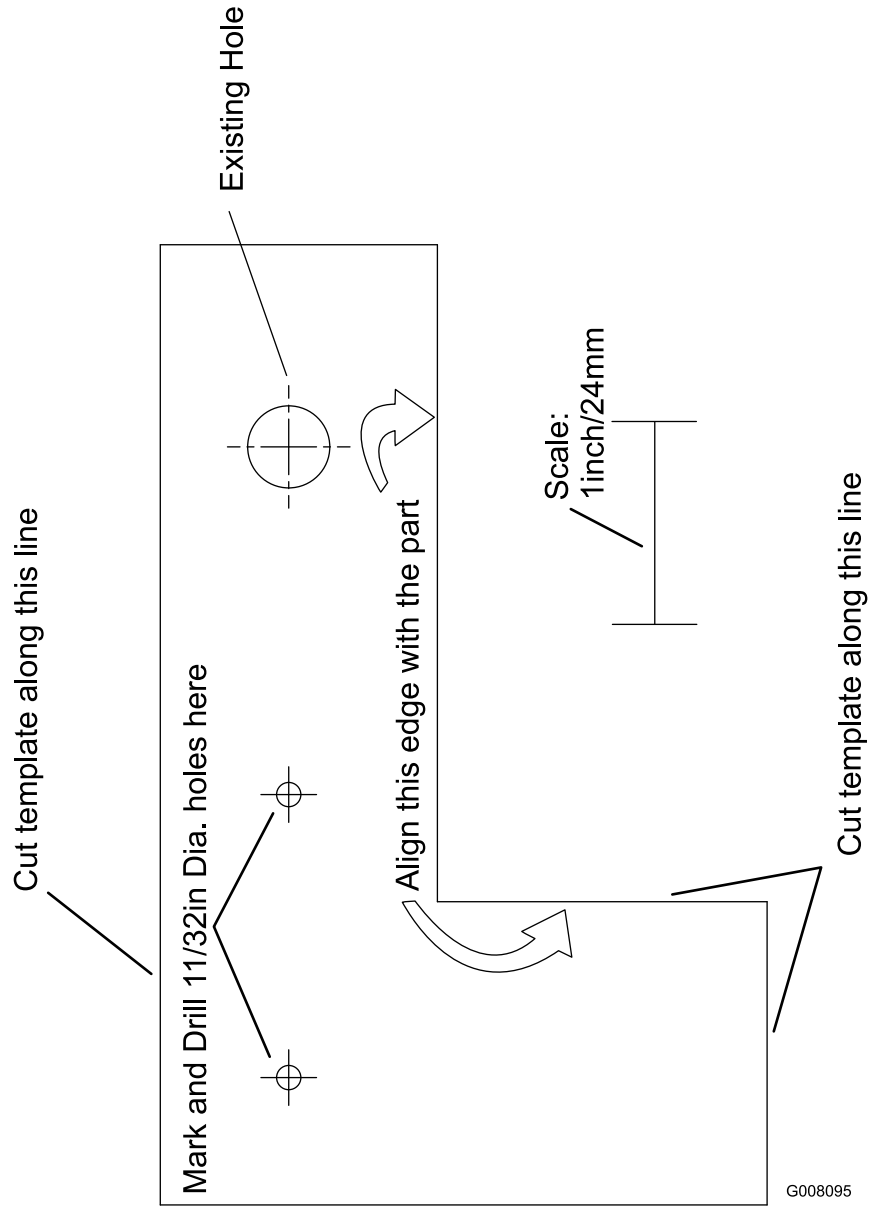

Figure 18

- | | |
|----------------|-------------------------|
| 1. Fuel filter | 4. Left side of machine |
| 2. Hose clamp | 5. Fuel shut-off valve |
| 3. Fuel pump | |

Template





Count on it.