



60in E-Z Vac™ Triple Bagging System Gen II Z Master® Mower

Model No. 78563 - 290000001 and up.

Parts Catalog

Ordering Replacement Parts

To order replacement parts, please supply the part number, the quantity, and the description of each part desired.

Understanding Reference Numbers

Each identified part in an illustration has a reference number. The reference number for a part also appears in the parts list, along with other information about the part.

This catalog uses two special reference number formats, one to indicate parts in a service assembly and another to indicate the quantity of a given part in an illustration.

Service Assembly Reference Numbers

Parts in service assemblies have reference numbers in the form a:b. The a represents the reference number of the entire service assembly and the b represents a sequential number unique to each part within the service assembly.

For example, a wheel assembly might be identified by reference number 6, the tire by 6:1, the valve by 6:2, and the wheel by 6:3. When you order the assembly identified by reference number 6, you receive all parts identified by reference numbers 6:1, 6:2, and 6:3. However, you may also order any part individually. Reference numbers of this type appear in illustrations and in part lists.

Reference Numbers Indicating Quantity

In an illustration, if a reference number indicates more than one part, the reference number has the form nX y. The n represents the quantity of the part, the X is the multiplication symbol, and the y represents the reference number.

For example, in an illustration, the reference number 2X 37 means that two of the parts identified by reference number 37 are indicated.

Contents

Description	Page	Description	Page
Bagger Mount Assembly 3	Bag and Tube Assembly 5
Hood and Frame Assembly 4	Weight Assembly 6

Part Description Abbreviations

Part descriptions in this catalog may include the following abbreviations.

AR. as required	HYD. hydraulic
ASM. assembly	LH. left hand
BBC. blade brake clutch	NI. nylon insert
CARR. carriage	NPTF. national pipe thread fine
DEG. degrees	PFH. phillips flat head
EXT. external	PPH. phillips pan head
FH. flat head	PPHTF. phillips pan head thread forming
GA. gauge	PRH. phillips round head
HD. heavy-duty	PTH. phillips truss head
HF. hex flange	PTO. power-take-off
HH. hex head	RH. right hand
HHF. hex head flange	ROPS. roll-over protection system
HHFTF. hex head flange thread forming	SFH. slotted fillister head
HJ. hex jam	SHH. slotted hex head
HLH. hex lag head	SHWH. slotted hex washer head
HOC. height-of-cut	SPH. slotted pan head
HSBH. hex socket button head	SQH. square head
HSFH. hex socket flat head	SRH. slotted round head
HSH. hex socket head	STD. standard
HWH. hex washer head	TAP. self tapping
HWHTF. hex washer head thread forming	TTH. torx truss head

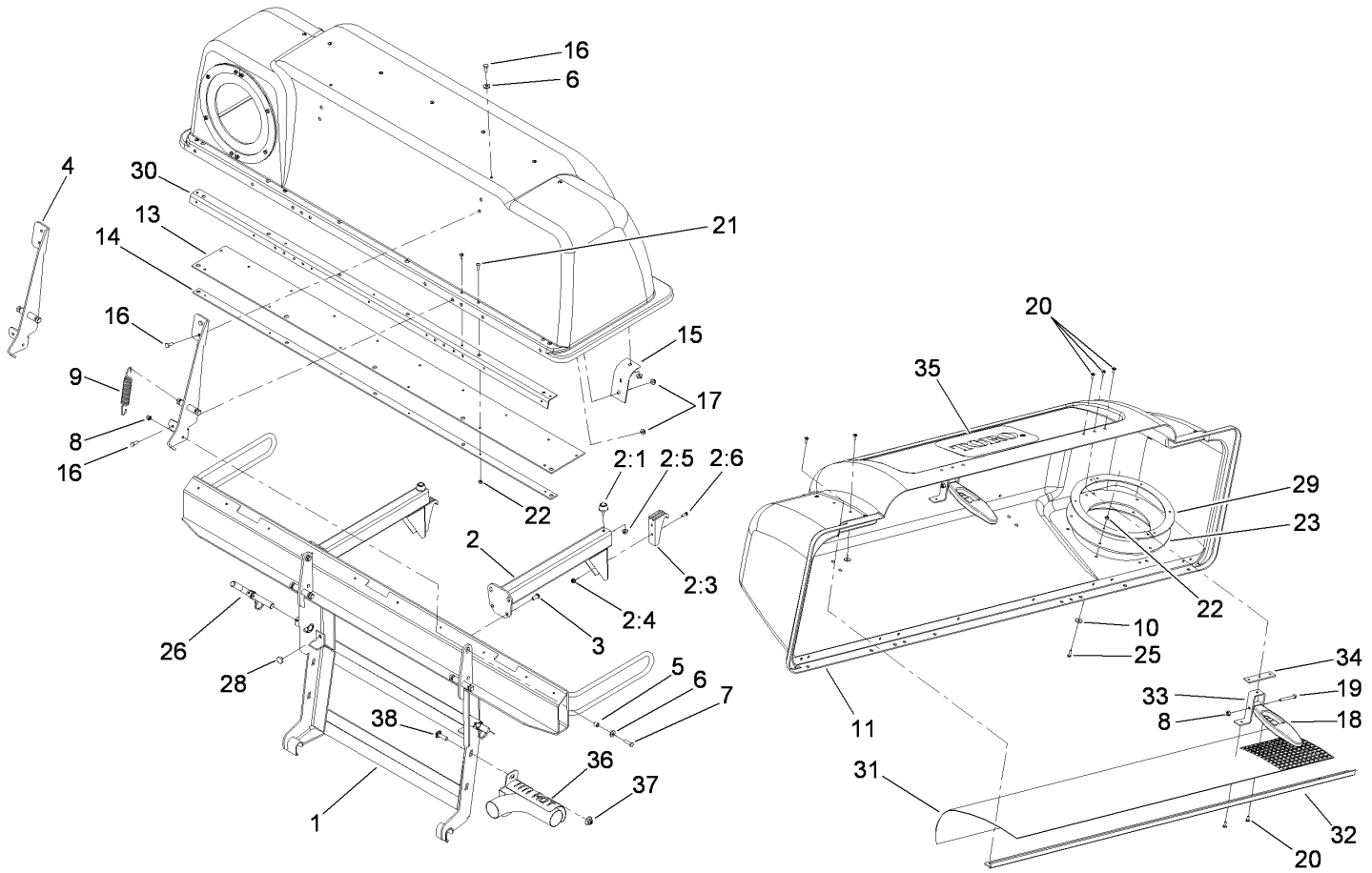

Hood and Frame Assembly

Ref	Part No.	Qty.	Description
1	109-8706-03	1	Frame-Uv, 3-Bag
2	103-5166	2	Bag Support ASM
2:1	1-523420	1	Bumper
2:3	1-653404	1	Catch
2:4	3290-148	2	Nut-HF
2:5	32128-33	1	Nut-HF
2:6	3290-500	2	Screw-PPH
3	3274-55	8	Screw-HSBH
4	109-8351-03	2	Hinge
5	1-633545	2	Spacer
6	3256-2	4	Washer-Flat
7	321-6	2	Screw-HH
8	3296-42	4	Nut-Lock, NI
9	1-653544	4	Spring-Extension
10	3256-61	23	Washer-Flat
11	112-1760	1	Hood ASM
13	103-0451	1	Seal-Hinge
14	103-0452-03	1	Plate-Backing
15	103-0391	2	Reinforcement-Hood, Bagger
16	321-4	10	Screw-HH
17	32128-33	10	Nut-HF
18	1-653403	2	Latch
19	321-11	2	Screw-HH
20	114439	46	Rivet-Pop

Ref	Part No.	Qty.	Description
21	1-803075	6	Screw-Head, Truss
22	3296-2	14	Nut-Lock NI
23	103-0439	1	Seal-Tube
25	3250-27	8	Screw-PPH
26	116-0458	2	Bagger Mount Pin ASM
28	1-513658	2	Bumper
29	103-0378	2	Clamp-Seal
30	103-0382-03	1	Stiffener-Bagger, Top
31	103-0440	1	Screen-Bagger
32	103-0380-03	1	Support-Screen
33	103-0379	2	Bracket-Mount
34	103-0376	2	Plate-Latch, Reinforcement
35	67-7310	1	Decal
36	109-9338	1	Diverter-Exhaust
37	109-6658	2	Nut-Flange, NI (Split)
38	3231-28	2	Screw-CARR

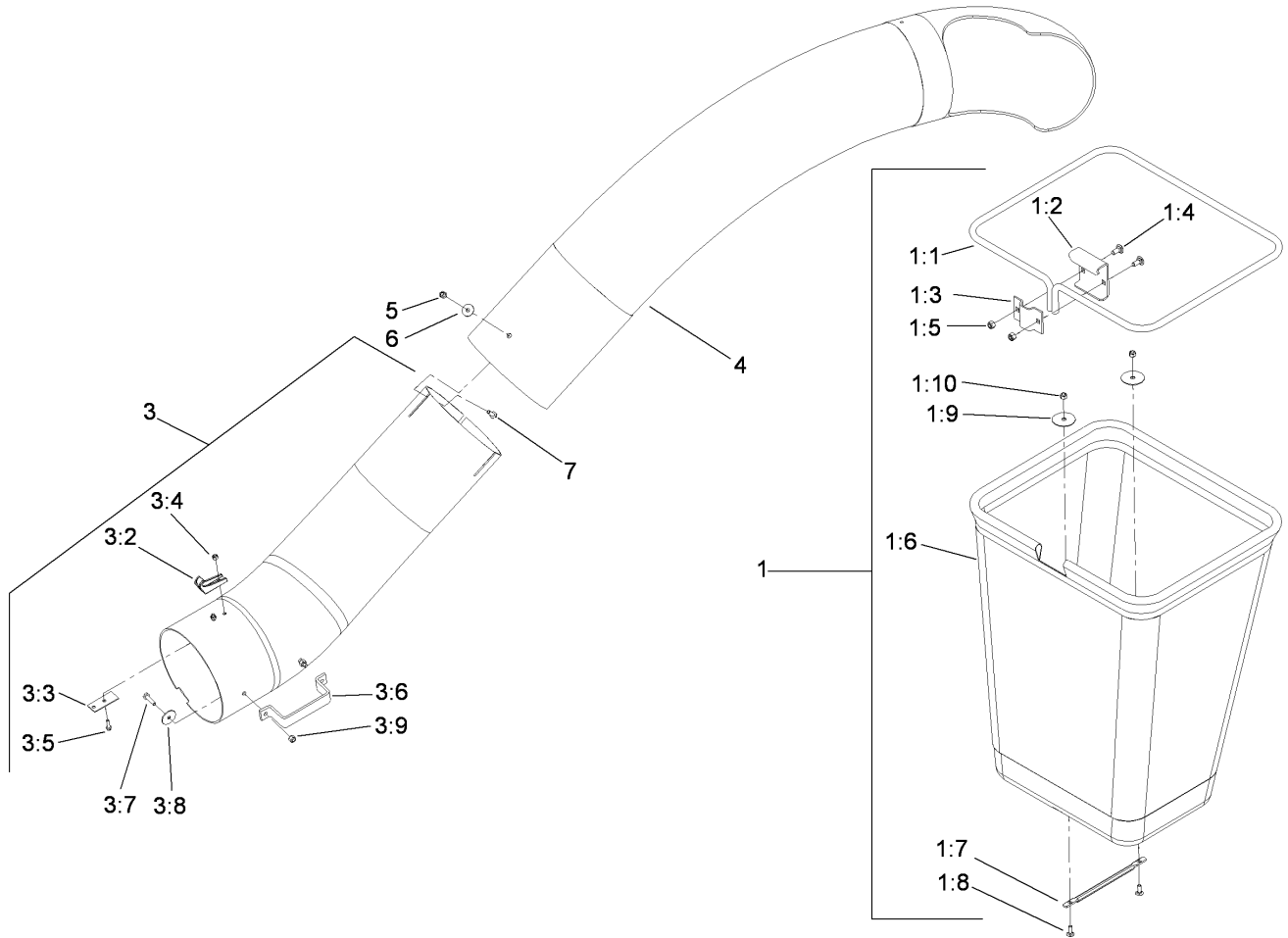

Bag and Tube Assembly

Ref	Part No.	Qty.	Description
1	116-0754	3	Bag And Frame ASM
1:1	1-653529-03	1	Frame-Bag
1:2	114973-03	1	Hanger-Bag
1:3	114974-03	1	Clamp
1:4	3230-1	2	Bolt-CARR
1:5	3296-29	2	Nut-Lock, NI
1:6	116-0757	1	Bag ASM
1:7	1-653566	1	Handle-Bag
1:8	3229-1	2	Screw-CARR
1:9	1-653036	2	Washer
1:10	3296-42	2	Nut-Lock, NI
3	109-1973	1	Lower Tube ASM
3:2	103-2897	2	Latch-Catch
3:3	103-3079	2	Plate-Backing
3:4	3296-2	4	Nut-Lock NI
3:5	32105-13	4	Screw-HWH
3:6	1-353005-03	1	Handle
3:7	321-6	2	Screw-HH
3:8	3256-55	2	Washer-Flat
3:9	3296-42	2	Nut-Lock, NI
4	109-1968	1	Tube-Upper
5	3296-2	3	Nut-Lock NI
6	3256-61	3	Washer-Flat
7	32105-13	3	Screw-HWH

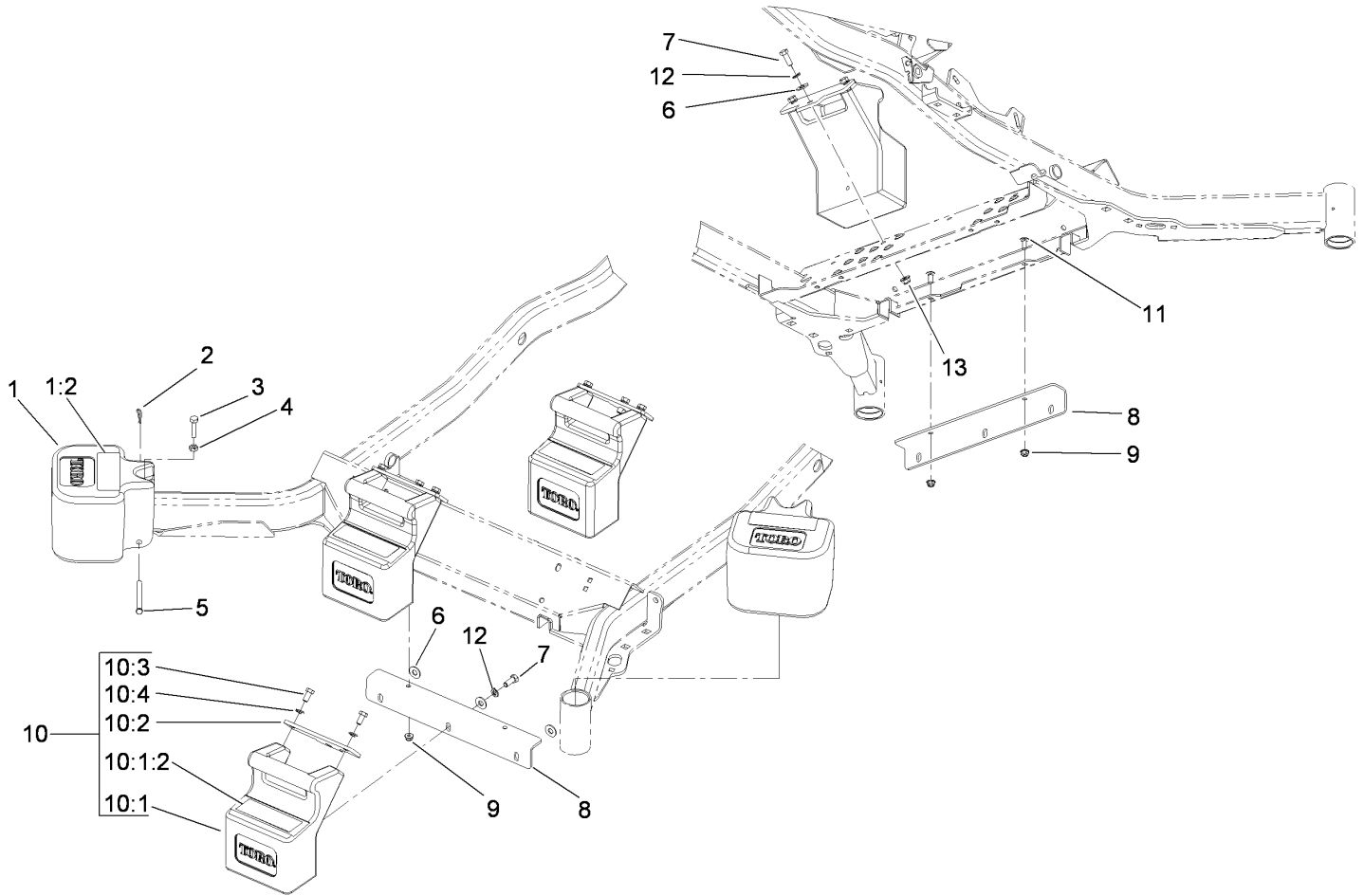

Weight Assembly

Ref	Part No.	Qty.	Description
1	115-3636	2	63 Lbs Weight ASM
1:2	106-0871	1	Decal-Warning, Counterweight
2	1-806003	2	Pin-Hair
3	323-50	2	Bolt-TAP
4	3217-7	2	Nut-Hex
5	100-1413	2	Pin-Clevis
6	3256-4	6	Washer-Flat
7	323-6	6	Screw-HH
8	115-3615-01	1	Bracket-Weight Mount
9	104-8300	2	Nut-Flange, NI
10	115-3617	3	Weight ASM
10:1	115-3618	1	Weight
10:1:2	106-0871	1	Decal-Warning, Counterweight
10:2	115-3616-01	1	Tab-Weight Support
10:3	323-4	2	Screw-HH
10:4	3253-5	2	Washer-Lock
11	3230-23	2	Screw-CARR
12	3253-5	6	Washer-Lock
13	104-8301	3	Nut-Flange, NI

NOTES

