



190-DH Lawn Tractor

Model No. 74590 - 230000001 and up.

Parts Catalog

Ordering Replacement Parts

To order replacement parts, please supply the part number, the quantity, and the description of each part desired.

Understanding Reference Numbers

Each identified part in an illustration has a reference number. The reference number for a part also appears in the parts list, along with other information about the part.

This catalog uses two special reference number formats, one to indicate parts in a service assembly and another to indicate the quantity of a given part in an illustration.

Service Assembly Reference Numbers

Parts in service assemblies have reference numbers in the form a:b. The a represents the reference number of the entire service assembly and the b represents a sequential number unique to each part within the service assembly.

For example, a wheel assembly might be identified by reference number 6, the tire by 6:1, the valve by 6:2, and the wheel by 6:3. When you order the assembly identified by reference number 6, you receive all parts identified by reference numbers 6:1, 6:2, and 6:3. However, you may also order any part individually. Reference numbers of this type appear in illustrations and in part lists.

Reference Numbers Indicating Quantity

In an illustration, if a reference number indicates more than one part, the reference number has the form nX y. The n represents the quantity of the part, the X is the multiplication symbol, and the y represents the reference number.

For example, in an illustration, the reference number 2X 37 means that two of the parts identified by reference number 37 are indicated.

Contents

Description	Page	Description	Page
Body Assembly	3	Operation Mower Lift Assembly	30
Front Axle Assembly	5	Electrical Wiring Harness Assembly	31
Steering Assembly	6	Electrical Switch Assembly	32
Body Hood Assembly	7	Electrical Switch Assembly (continued)	33
Engine Assembly	9	Electrical Switch Assembly (continued)	34
Operation Brake/By-Pass Assembly	10	Cylinder Assembly Briggs and Stratton 406777-0157-E1	35
Operation Travel Pedal Assembly	11	Cylinder Head Assembly Engine Briggs and Stratton Model 406777-0157-E1	36
Transmission Drive Assembly	12	Crankshaft Assembly Engine Briggs and Stratton Model 406770-0157-E1	37
Control Shaft Assembly	14	Carburetor Assembly Briggs and Stratton 406777-0157-E1	38
Differential Gear Assembly	15	Blower Housing Assembly Briggs and Stratton 406777-0157-E1	39
Final Pinion Assembly	16	Governor Assembly Briggs and Stratton 406777-0157-E1	40
Axle Shaft Assembly	17	Oil Filter, Tube, and Pump Assembly Briggs and Stratton 406777-0157-E1	41
Brake Assembly	18	Flywheel Assembly Briggs and Stratton 406777-0157-E1	42
Fan Pulley Assembly	19	Starter Assembly Briggs and Stratton 406777- 0157-E1	43
Range Shift Assembly	20	Carburetor Overhaul Kit Assembly Briggs and Stratton 406777-0157-E1	44
Center Case Assembly	21		
Pump Shaft Assembly	22		
Motor Shaft Assembly	23		
Transaxle Case Assembly	24		
Grass Collector Assembly	25		
Chute Collector Assembly	26		
Cutting Pan, Mower Housing Assembly	27		
Cutting Pan-Bag on Demand Assembly	28		
Cutting Pan Drive Assembly	29		

Part Description Abbreviations

Part descriptions in this catalog may include the following abbreviations.

AR. as required	HYD. hydraulic
ASM. assembly	LH. left hand
BBC. blade brake clutch	NI. nylon insert
CARR. carriage	NPTF. national pipe thread fine
DEG. degrees	PFH. phillips flat head
EXT. external	PPH. phillips pan head
FH. flat head	PPHTF. phillips pan head thread forming
GA. gauge	PRH. phillips round head
HD. heavy-duty	PTH. phillips truss head
HF. hex flange	PTO. power-take-off
HH. hex head	RH. right hand
HHF. hex head flange	ROPS. roll-over protection system
HHFTF. hex head flange thread forming	SFH. slotted fillister head
HJ. hex jam	SHH. slotted hex head
HLH. hex lag head	SHWH. slotted hex washer head
HOC. height-of-cut	SPH. slotted pan head
HSBH. hex socket button head	SQH. square head
HSFH. hex socket flat head	SRH. slotted round head
HSH. hex socket head	STD. standard
HWH. hex washer head	TAP. self tapping
HWHTF. hex washer head thread forming	TTH. torx truss head

Footnotes

- | | |
|---|---|
| ❶ Not illustrated | ❷ Not serviced separately |
| ❸ Included in Gasket Set-Ref. 358. | ❹ Included in Carburetor Kit-Ref. 121 |
| ❺ Included in Valve Overhaul Kit-Ref. 1033. | ❻ Included in Carburetor Gasket Set-Ref. 977. |

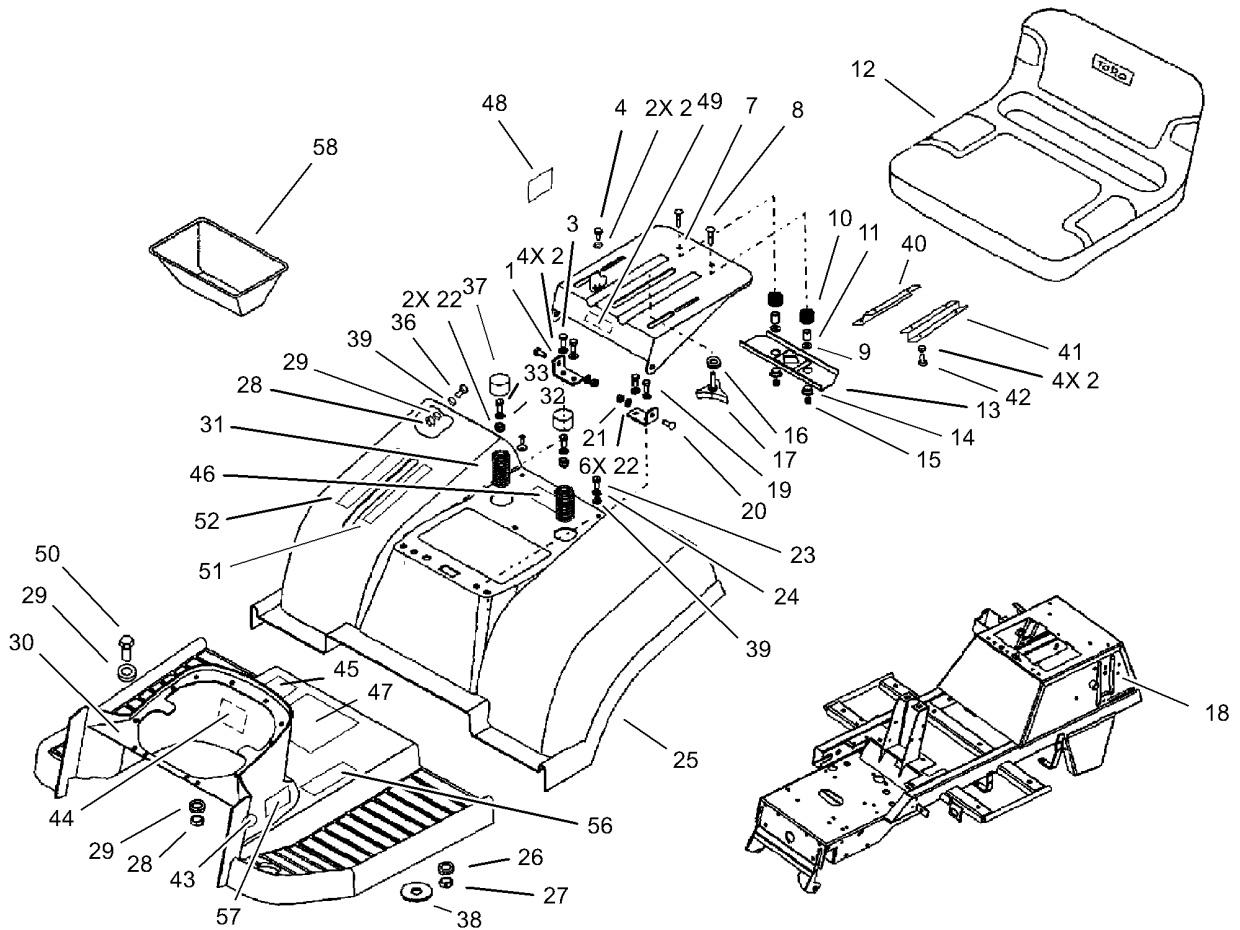

Body Assembly

Ref	Part No.	Qty.	Description
1	104-2926	2	Bracket-Support, Seat
2	42-9850	10	Washer-Lock, Spring
3	33114-025	4	Screw-HH
4	104-3192	2	Bolt-Hex
7	104-2929	1	Support-Seat
8	104-2930	2	Bolt-Carriage
9	104-2931	2	Washer-Flat
10	104-2932	2	Spring-Seat
11	104-2933	2	Spacer-Split
12	92-6511	1	Seat-V-511
13	104-2934	1	Bracket
14	104-2935	2	Bushing
15	33023-00	2	Nut-Lock
16	104-2936	2	Washer-Spring
17	104-2937	2	Knob-Adj.
18	104-2938	1	Frame-Chassis
19	33114-030	1	Screw-HH
20	104-2939	2	Screw-Support, Seat
21	33094-00	6	Washer-Plain
22	33024-00	8	Nut-Lock
23	104-2940	2	Screw-HSFH
24	104-2941	2	Washer-Finish
25	106-5752	1	Fender
26	33095-00	4	Washer-Flat

Ref	Part No.	Qty.	Description
27	33025-00	4	Nut-Lock
28	87-5140	6	Nut-Lock
29	104-2943	6	Washer-Flat
30	104-2944	1	Footrest ASM
31	104-2945	2	Spring-Seat
32	104-2946	6	Washer-Plain
33	33114-020	2	Screw-HH
36	104-2948	6	Bolt-Carriage
37	104-2857	2	Cap-Hub
38	104-2951	2	Washer-Rubber
39	104-2952	2	Washer-Rubber
40	104-2953	1	Bracket-Right Seat
41	104-2954	1	Bracket-Left Seat
42	104-3195	4	Screw
43	104-3237	1	Decal-Brake, Parking
44	104-3238	1	Decal-Starting
45	104-3241	1	Decal-Operation, Hydro
46	104-3242	1	Decal-Bag To Frame
47	104-2903	1	Decal-Instruction
48	99-5340	1	Decal-Switch
49	93-7276	1	Decal-Danger
50	60-6910	6	Screw
51	104-3239	1	Decal-HOC, LH
52	104-3240	1	Decal-HOC, RH

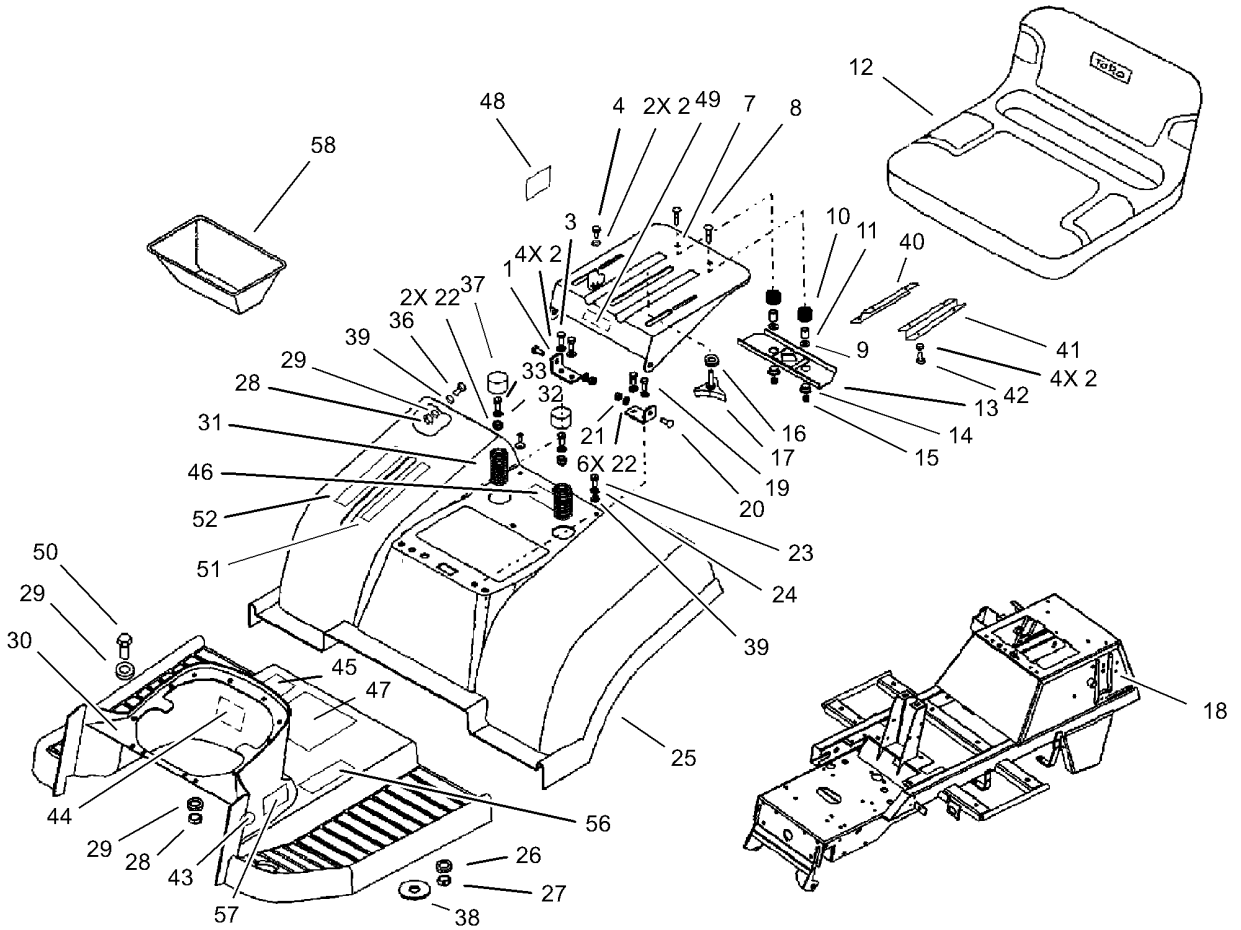

Body Assembly (continued)

Ref	Part No.	Qty.	Description
56	106-8552	1	Decal-Operation
57	106-8554	2	Decal-Tower
58	106-5756	1	Box-Battery

--	--	--	--

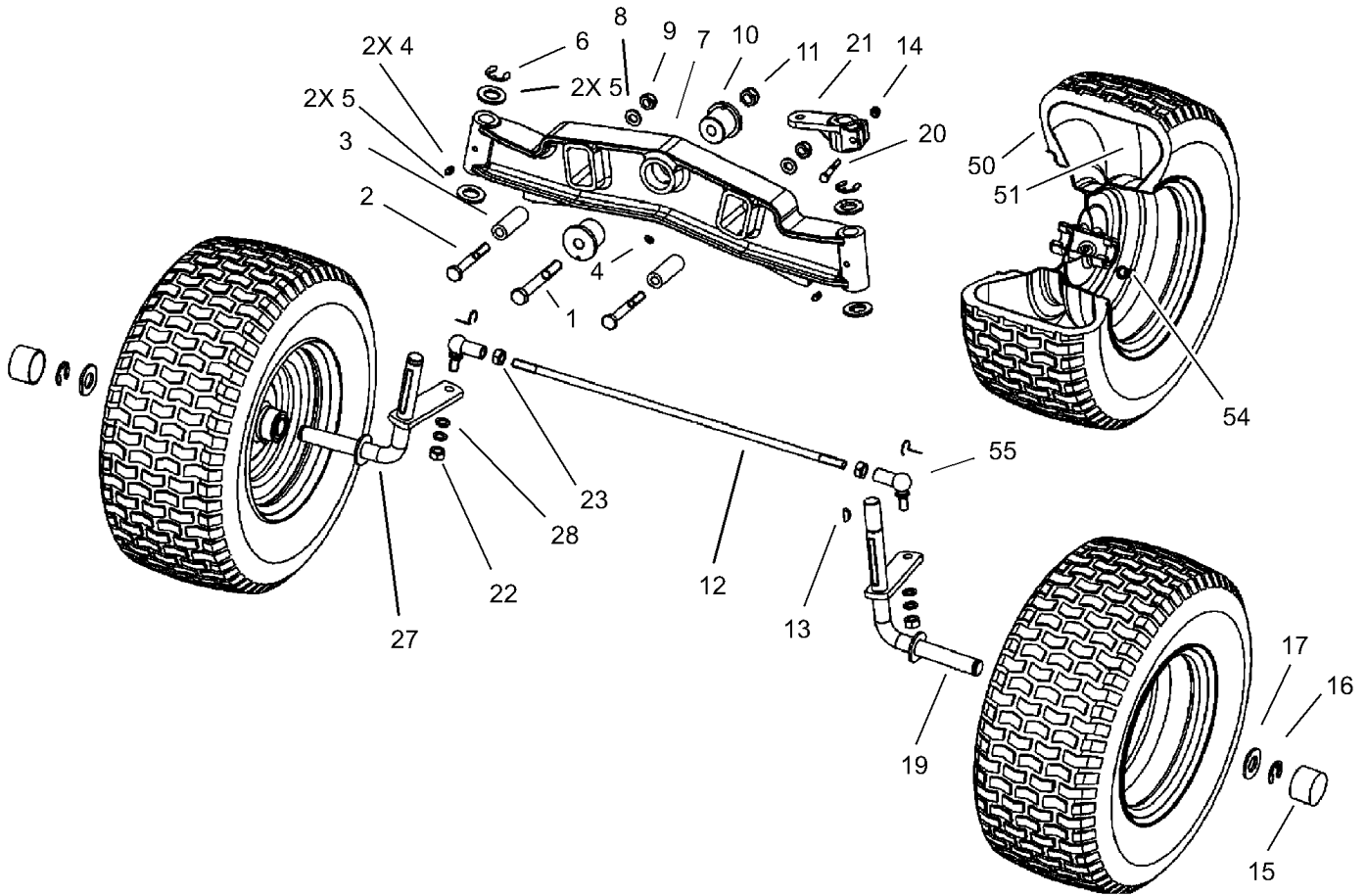

Front Axle Assembly

Ref	Part No.	Qty.	Description
1	33116-090	1	Screw-HH
2	33115-080	2	Screw-HH
3	104-2851	2	Spacer
4	104-2904	3	Fitting-Grease
5	104-2905	4	Washer-Flat
6	104-2891	2	Clip-Spring
7	104-2852	1	Axle-Front
8	104-2906	2	Washer-Flat
9	33025-00	2	Nut-Lock
10	104-2890	2	Bushing-Axle, Front
11	104-2907	1	Nut-Self Locking
12	104-2855	1	Rod-Tie, Front Axle
13	104-2856	1	Key-Woodruff
14	33023-00	1	Nut-Lock
15	104-2857	2	Cap-Hub
16	104-2891	2	Clip-Spring
17	104-3206	2	Washer
19	104-2861	1	Spindle-LH
20	33113-045	1	Screw-HH
21	104-2862	1	Lever-Spindle, Steering
22	33015-00	2	Nut-Hex
23	21-0360	2	Nut-Hex
27	104-2867	1	Spindle-RH
28	106-5757	4	Washer

Ref	Part No.	Qty.	Description
50	104-2869	2	Tire- Turf Saver 2 Ply
51	104-2870	2	Tube
54	104-2875	2	Valve-Tyre
55	104-2876	2	Joint-Ball, Angle

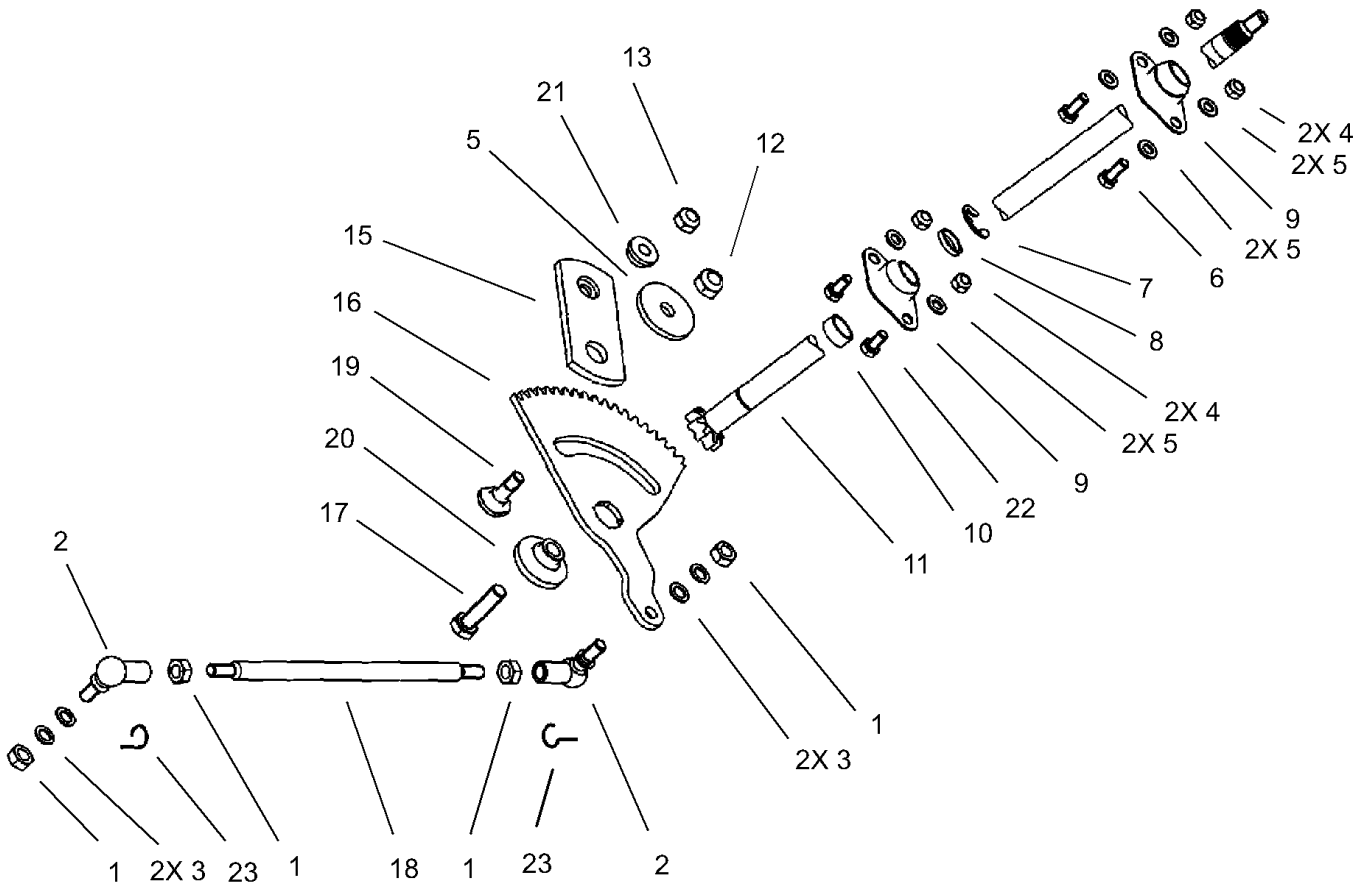

Steering Assembly

Ref	Part No.	Qty.	Description
1	33015-00	4	Nut-Hex
2	104-2876	2	Joint-Ball, Angle
3	106-5757	4	Washer
4	33024-00	4	Nut-Lock
5	33094-00	6	Washer-Plain
6	33114-020	2	Screw-HH
7	104-2891	1	Clip-Spring
8	104-2877	1	Spacer-Upper
9	104-2878	2	Bearing-Spherical
10	104-2879	1	Spacer-Lower
11	106-5773	1	Shaft-Steering
12	33026-00	1	Nut-Lock
13	33025-00	1	Nut-Lock
15	105-1238	1	Plate-Steering
16	104-2883	1	Gear-Sector
17	104-2910	1	Screw-Hex
18	104-2886	1	Link-Drag
19	105-1239	1	Bolt-Shoulder
20	105-1240	1	Pivot-Steering
21	105-1241	1	Bushing
22	33114-016	2	Screw-HH
23	104-2865	2	Stirrups-Locking

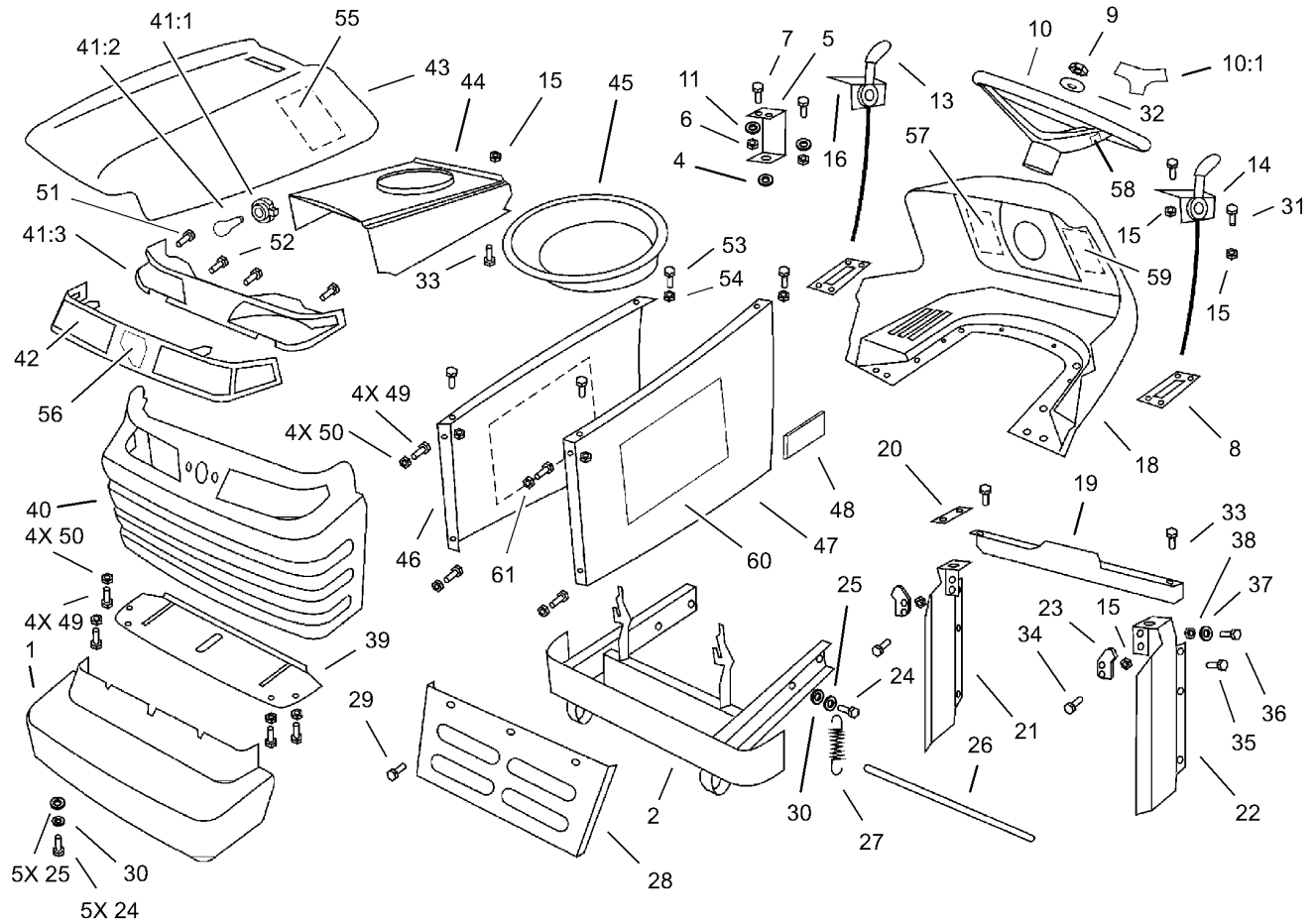

Body Hood Assembly

Ref	Part No.	Qty.	Description
1	104-2955	1	Cover-Bumper
2	104-2956	1	Bumper
3	104-2958	1	Hood ASM
4	104-2959	1	Bushing
5	104-2960	1	Holder-Tank, Fuel
6	33023-00	2	Nut-Lock
7	104-2961	2	Screw
8	104-2962	2	Brace
9	33026-00	1	Nut-Lock
10	98-1472	1	Wheel-Steering
10:1	98-1468	1	Cover-Wheel, Steering
11	33094-00	2	Washer-Plain
13	66-0120	2	Knob
14	92-6783	1	Control-Choke, Twin
15	87-5140	14	Nut-Lock
16	92-6784	1	Control-Throttle, Twin
18	104-2969	1	Panel-Dash
19	104-2970	1	Brace
20	104-2971	1	Bracket
21	104-2972	1	Panel-Right
22	104-2973	1	Panel-Left
23	92-6960	2	Latch-Hood
24	33114-020	6	Screw-HH
25	104-2946	6	Washer-Plain

Ref	Part No.	Qty.	Description
26	104-2974	1	Bar-Safety
27	104-2975	1	Spring-Hood
28	104-2976	1	Shield-Heat
29	104-2977	3	Screw-Slf Drl
30	42-9850	5	Washer-Lock, Spring
31	106-5759	2	Screw
32	106-5758	1	Washer
33	104-2980	6	Screw
34	104-2981	4	Screw
35	104-2982	4	Screw
36	104-2983	2	Screw
37	104-3175	6	Washer
38	104-2985	6	Nut-Hex
39	104-2986	1	Bracket
40	100-1344	1	Grill
41	7228	2	Bulb
41	88-3970	1	Reflector And Lamp ASM
41:1	111686	2	Socket-Light
41:2	7228	2	Bulb
41:3	93-8741	1	Reflector
42	92-6656	1	Lens - Headlight
43	92-6658	1	Hood-Top
44	104-2987	1	Hood - Baffle
45	104-2989	1	Plenum-Air

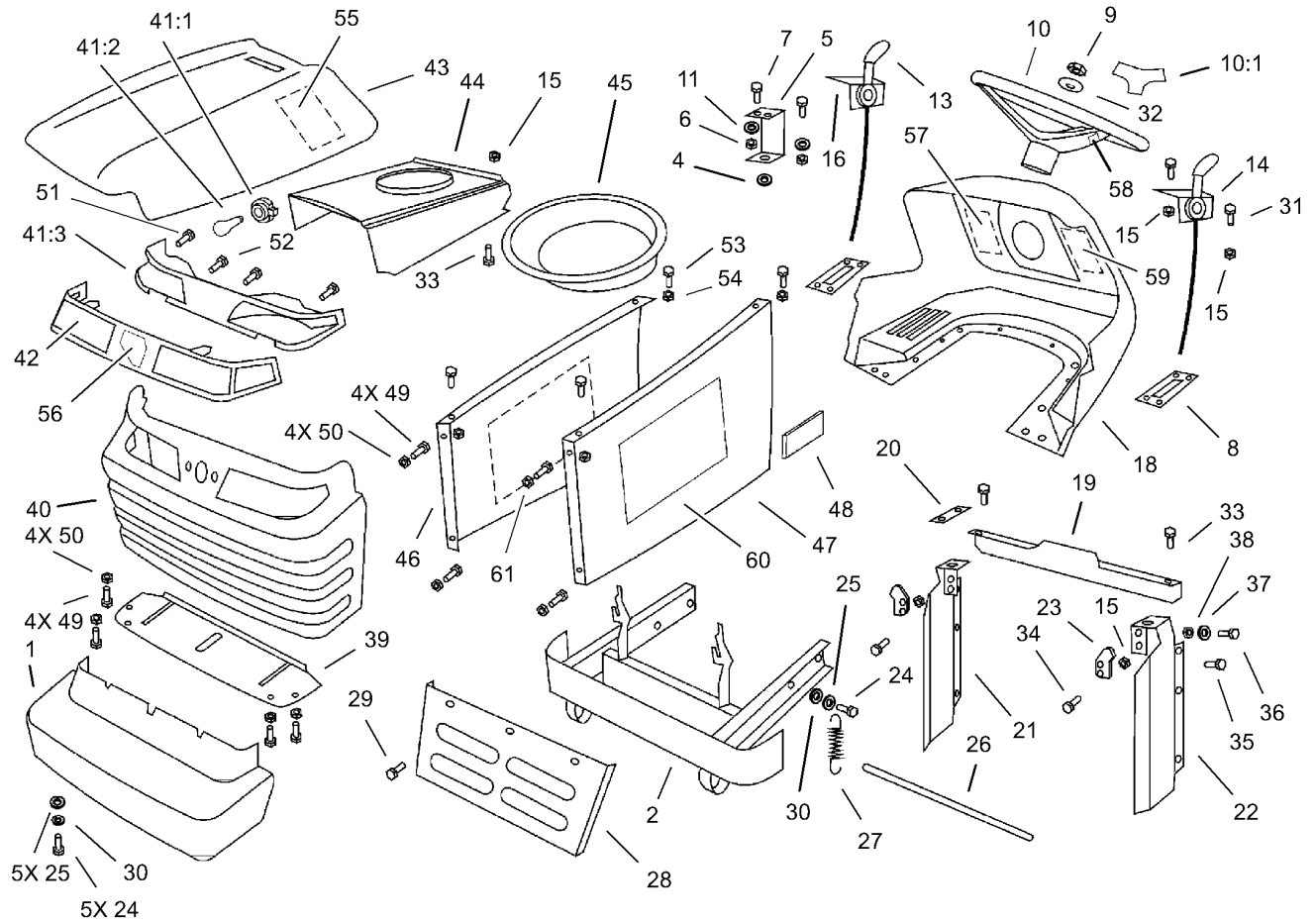

Body Hood Assembly (continued)

Ref	Part No.	Qty.	Description
46	92-6650	1	Side-Hood, RH
47	92-6652	1	Side-Hood, LH
48	92-7148	2	Foam-Sidepanel
49	104-2990	8	Screw
50	104-2991	8	Nut-Hex
51	46-8093	2	Screw-Plastite
52	32144-32	2	Screw
53	32105-15	4	Screw
54	92-7006	4	Nut
55	94-1980	2	Foam-Hood
56	92-6987	1	Emblem-Horsehead
57	104-3234	1	Decal
58	98-1459	1	Decal
59	104-3233	1	Decal-Choke/PTO
60	95-0801	1	Decal-Hood, LH
61	95-0800	1	Decal-Hood, RH

--	--	--	--

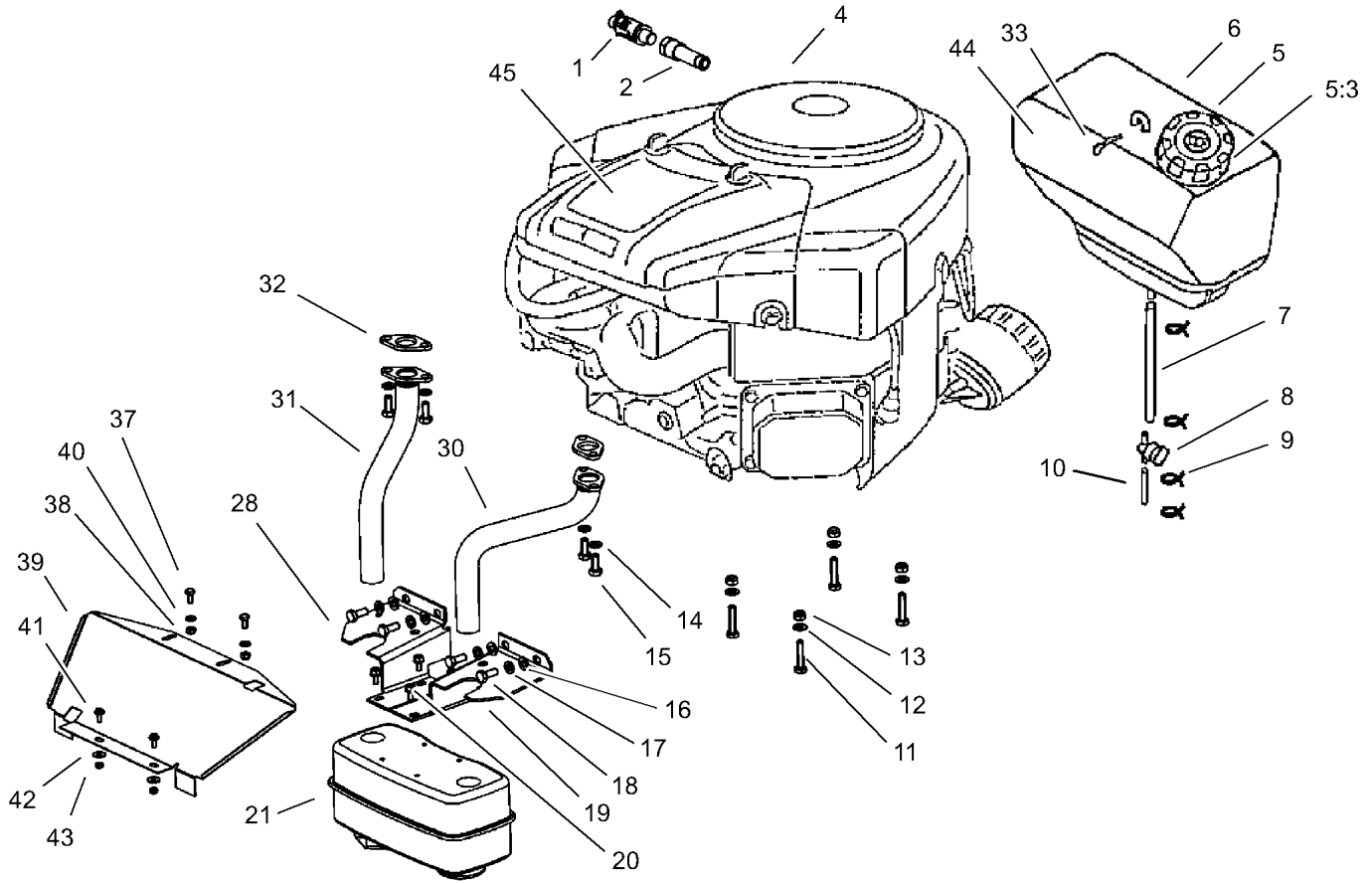

Engine Assembly

Ref	Part No.	Qty.	Description
1	104-3208	1	Valve-Oil Drain
2	106-5764	1	Coupler-Oil Drain
24		1	Engine-Briggs And Stratton Model No. 406777-0157-E1
5	88-3980	1	Gas Cap ASM
5:3	88-4010	1	Gasket-Cap, Gas
6	104-3057	1	Tank-Fuel
7	106-0890	1	Line-Fuel
8	104-3224	1	Valve-Tank, Fuel
9	104-3212	4	Clamp-Line, Fuel
10	106-0891	1	Line-Fuel
11	33114-035	4	Screw-HH
12	33094-00	4	Washer-Plain
13	33024-00	4	Nut-Lock
14	104-2927	4	Washer-Spring
15	322-3	4	Screw-HH
16	33094-00	4	Washer-Plain
17	104-2927	4	Washer-Spring
18	33114-020	4	Screw-HH
19	104-3214	1	Guard-Muffler, LH
20	106-5763	4	Screw
21	104-3225	1	Muffler
28	104-3215	1	Guard-Muffler, RH
30	104-3216	1	Tube-Exhaust, LH

Ref	Part No.	Qty.	Description
31	104-3217	1	Tube-Exhaust, RH
32	104-3226	2	Gasket-Exhaust
33	104-3144	1	Pin-Hair
37	33113-012	2	Screw-HH
38	33023-00	2	Nut-Lock
39	104-3219	1	Shield-Heat
40	33093-00	2	Washer-Flat
41	104-2980	2	Screw
42	104-2943	2	Washer-Flat
43	87-5140	2	Nut-Lock
44	104-3220	1	Tank-Fuel W/Cap
45	104-2901	1	Decal-Engine

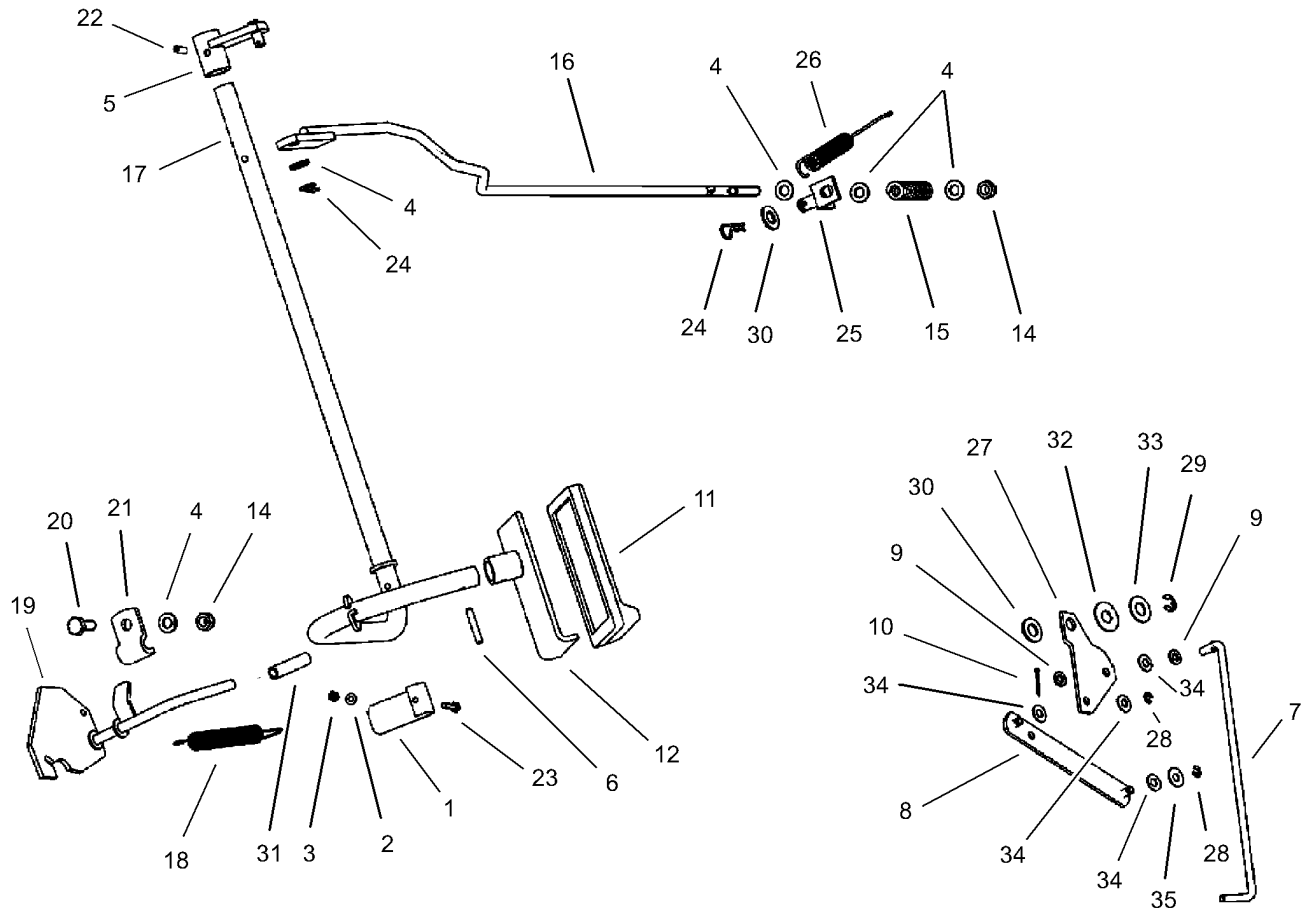

Operation Brake/By-Pass Assembly

Ref	Part No.	Qty.	Description
1	104-2992	1	Lever-Spring
2	104-2984	1	Washer
3	104-2985	1	Nut-Hex
4	33094-00	5	Washer-Plain
5	104-2993	1	Bracket-Rod, Brake
6	104-2994	1	Pin-Spring
7	104-2995	1	Rod-Lever, Bypass
8	104-3324	1	Lever-Bypass
9	104-3193	2	Washer
10	104-2997	1	Pin-Cotter
11	104-2998	1	Pad-Pedal
12	104-2999	1	Pedal
14	33024-00	2	Nut-Lock
15	104-3002	1	Spring-Brake
16	104-3003	1	Rod-Connecting, Brake
17	104-3246	1	Shaft-Brake
18	104-3005	1	Spring-Brake, Hand
19	104-3006	1	Lever-Brake, Hand
20	33114-020	1	Screw-HH
21	104-3007	1	Clamp-Lever, Parking Brake
22	104-3008	1	Pin-Spring
23	104-3009	1	Screw-Hex
24	104-3016	2	Pin-Cotter
25	104-3011	1	Bracket-Rod, Brake

Ref	Part No.	Qty.	Description
26	104-3012	1	Spring
27	104-3323	1	Plate-Bypass
28	104-3014	2	Stirrup
29	104-3015	1	Stirrup
30	33095-00	2	Washer-Flat
31	104-3247	1	Cap
32	106-5768	1	Washer
33	106-5769	1	Washer
34	106-5770	4	Washer
35	106-5771	1	Washer

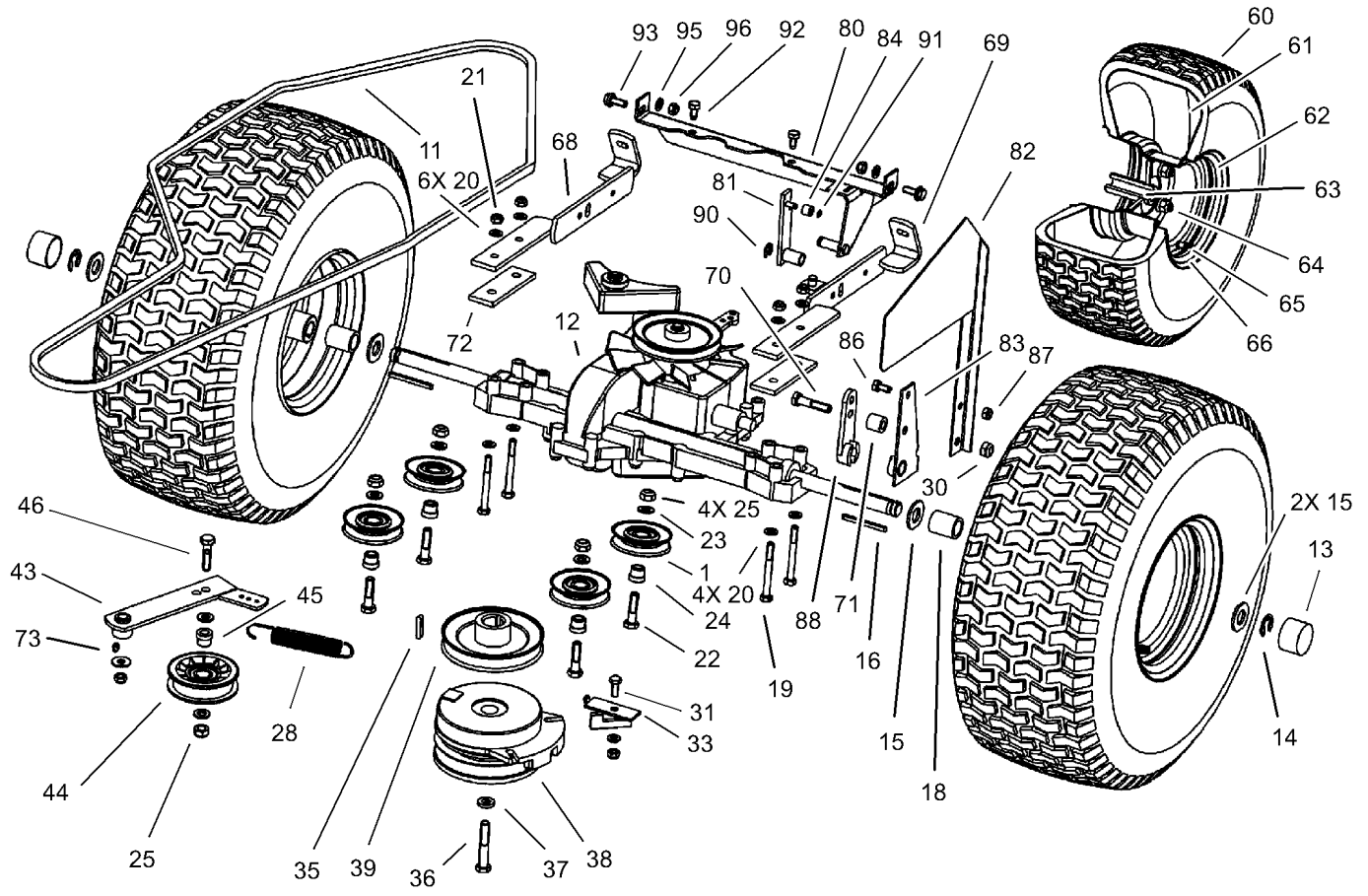

Transmission Drive Assembly

Ref	Part No.	Qty.	Description
1	104-2887	4	Pully-Idler
11	104-2888	1	V-Belt-Traction
12	104-2889	1	Transmission
13	104-2857	2	Cap-Hub
14	104-2891	2	Clip-Spring
15	104-3206	4	Washer
16	104-2892	2	Key-Square
18	104-2895	2	Spacer-Axle
19	33114-080	4	Screw-HH
20	33094-00	10	Washer-Plain
21	33024-00	6	Nut-Lock
22	33115-040	4	Screw-HH
23	33095-00	4	Washer-Flat
24	104-2896	4	Bushing-Idler
25	33025-00	5	Nut-Lock
28	104-2897	1	Spring
30	33025-00	1	Nut-Lock
31	33114-020	1	Screw-HH
33	104-2898	1	Retainer
35	104-2899	1	Key-Square
36	3212-10	1	Screw-HH
37	93-9043	1	Washer-Spring, Belleville
38	104-3334	1	Clutch-Electric
39	104-2911	1	Pulley-Engine

Ref	Part No.	Qty.	Description
43	104-2912	1	Arm-Idler
44	104-2913	1	Pulley-Idler
45	104-2896	1	Bushing-Idler
46	33115-040	1	Screw-HH
60	104-2917	2	Tire-Turf Saver 4 Ply
61	104-2918	2	Tube
62	104-3196	2	Wheel ASM
63	104-2921	2	Hub-Wheel
64	104-2922	8	Nut-Wheel
65	106-8596	2	Valve-Tire
66	104-2919	2	Rim
68	106-8594	1	Bracket-Right
69	106-8593	1	Bracket-Left
70	33115-045	1	Screw-HH
71	104-2925	1	Sleeve
72	104-3343	2	Plate-Reinforcing
73	104-2904	1	Fitting-Grease
80	104-3327	1	Bar ASM
81	104-3328	1	Arm-Switch
82	104-3325	1	Arm-Control, Cruise
83	104-3326	1	Tenon
84	104-3329	1	Roller
86	33114-010	1	Screw-HH
87	33024-00	1	Nut-Lock

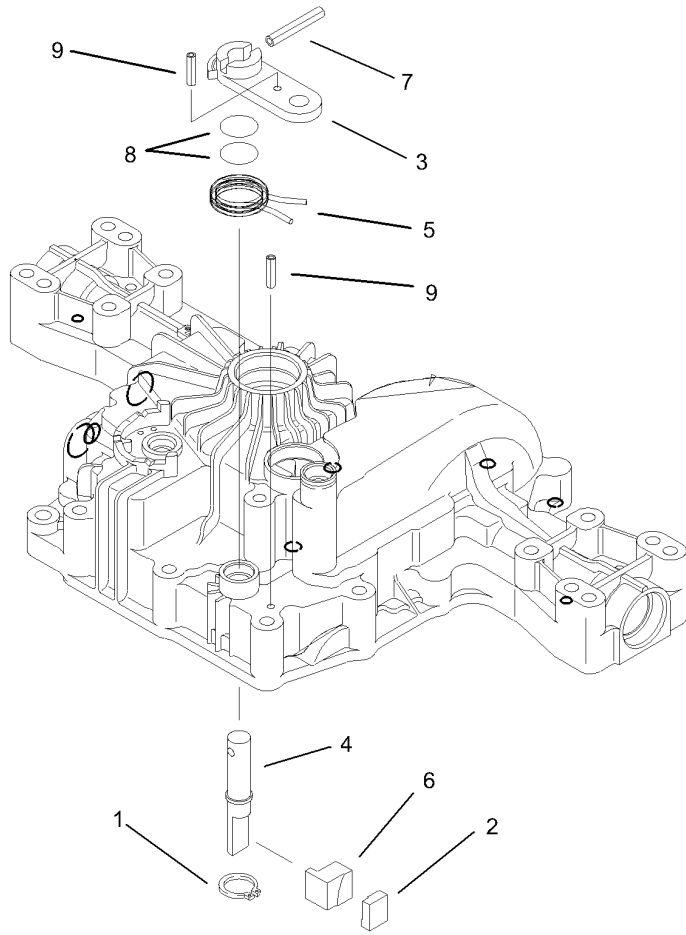

Brake Assembly

Ref	Part No.	Qty.	Description	
1	104-3313	1	Ring	
2	104-3314	1	Shoe-Brake	
3	104-3315	1	Arm-Brake	
4	104-3316	1	Shaft-Brake	
5	104-3317	1	Spring-Return, Brake	
6	104-3318	1	Actuator-Brake	
7	92-0767	1	Pin	
8	92-0786	2	O-Ring	
9	104-3319	2	Pin	

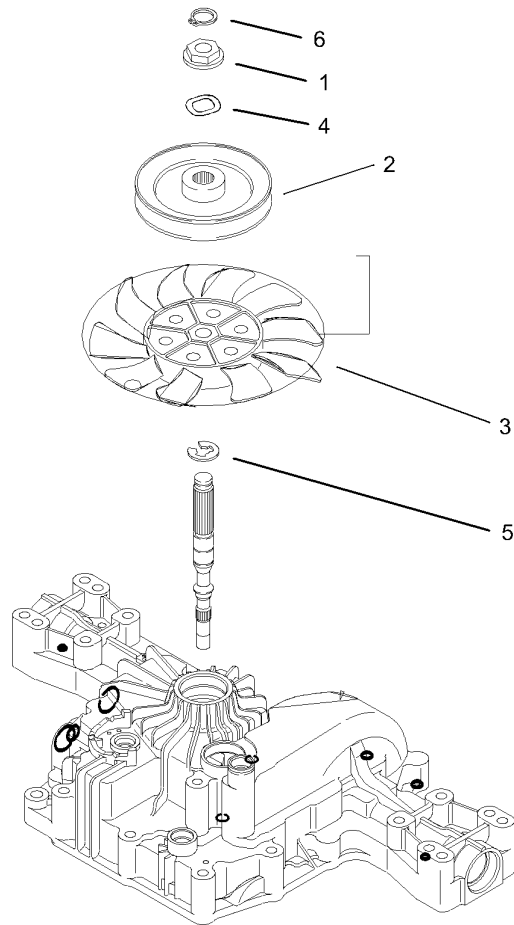

Fan Pulley Assembly

Ref	Part No.	Qty.	Description				
1	104-3320	1	Collar-Spline				
2	104-3197	1	Pulley-Transmission				
3	104-3199	1	Fan- Transmission				
4	104-3321	1	Washer-Lock				
5	93-0387	1	E-Ring				
6	104-3198	1	E-Ring				

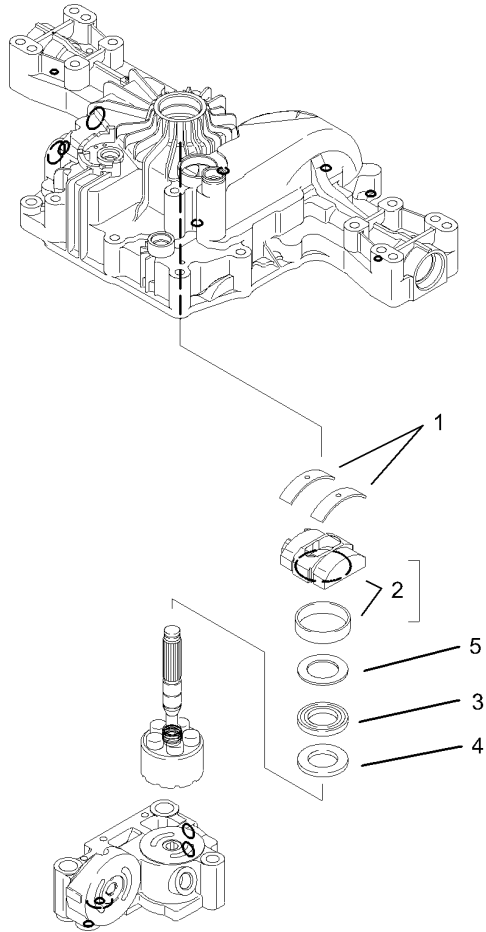

Range Shift Assembly

Ref	Part No.	Qty.	Description
1	104-3286	2	Metal-Thrust
2	104-3287	1	Plate-Swash
3	104-3288	1	Bearing
4	104-3289	1	Plate-Thrust, A
5	104-3290	1	Plate-Thrust, B

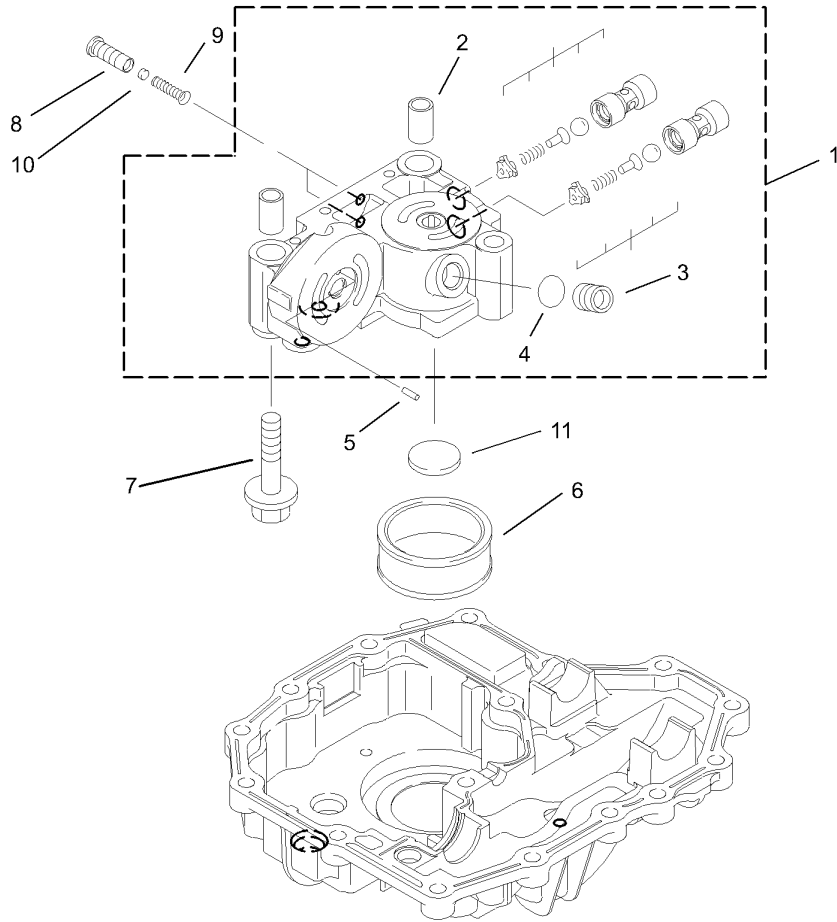

Center Case Assembly

Ref	Part No.	Qty.	Description				
1	104-3267	1	Case-Center				
2	104-3268	2	Pin-Knock				
3	104-3269	1	Plug				
4	93-0419	1	Packing				
5	104-3270	1	Pin				
6	104-3271	1	Filter				
7	104-3272	3	Bolt				
8	104-3273	2	Valve				
9	104-3274	2	Spring				
10	104-3275	2	Filter				
11	104-3257	1	Magnet				

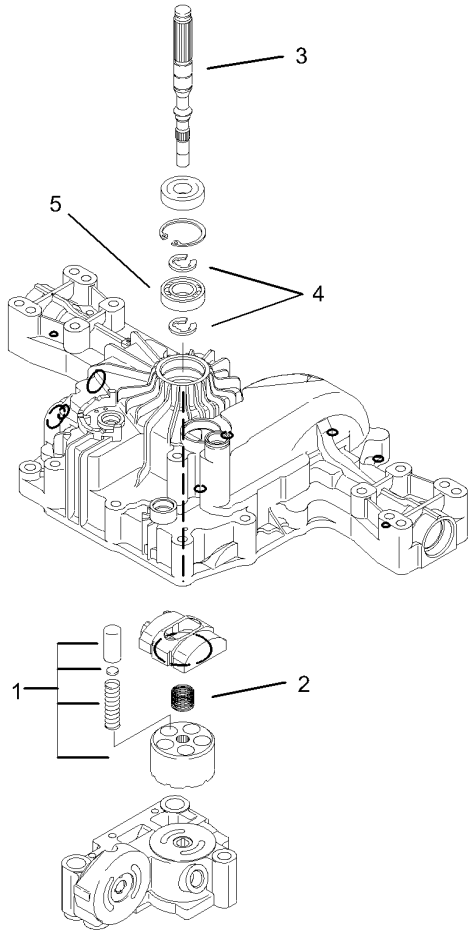

Pump Shaft Assembly

Ref	Part No.	Qty.	Description
1	104-3276	1	Block-Cylinder
2	104-3277	1	Spring-Pump
3	104-3278	1	Shaft-Pump
4	93-0387	2	E-Ring
5	93-0374	1	Bearing-Ball

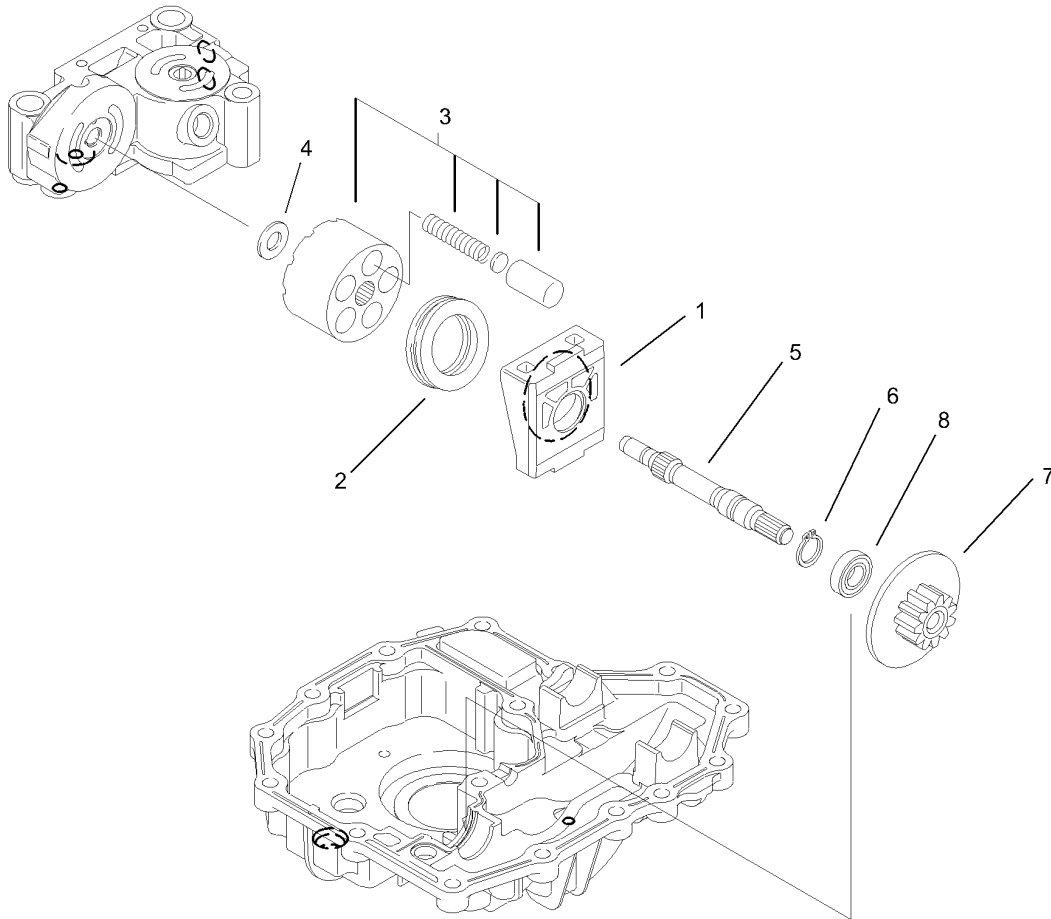

Motor Shaft Assembly

Ref	Part No.	Qty.	Description
1	104-3279	1	Housing
2	104-3280	1	Bearing
3	104-3281	1	Block-Cylinder
4	104-3282	1	Washer
5	104-3283	1	Shaft-Motor
6	93-0373	1	Ring-Snap
7	104-3284	1	Motor-Gear
8	104-3285	1	Bearing

--	--	--	--

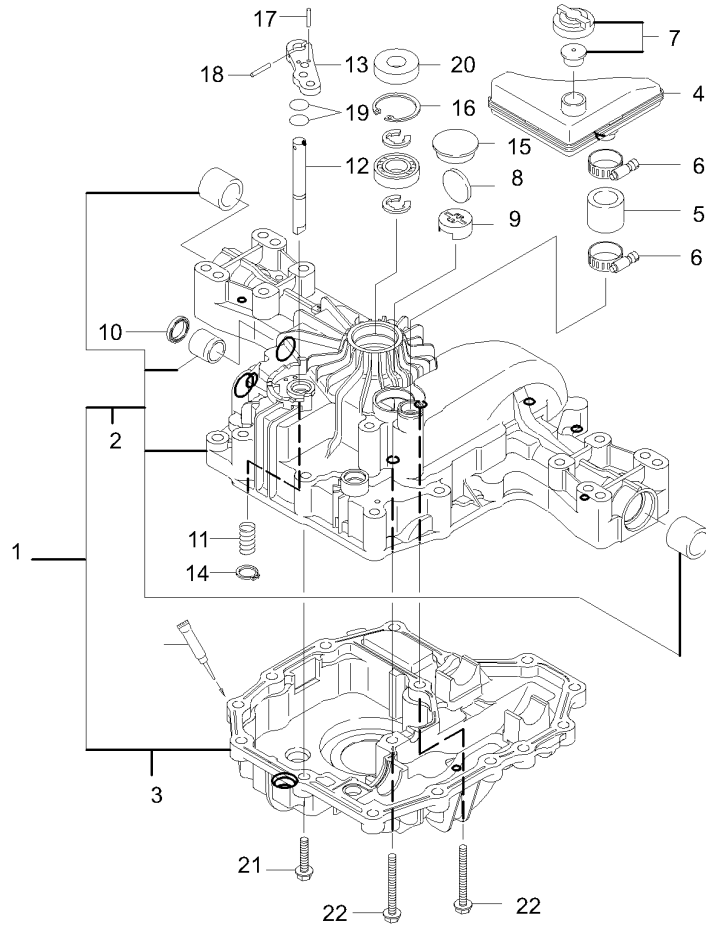

Transaxle Case Assembly

Ref	Part No.	Qty.	Description
1	104-3251	1	Transaxle Case Set
2	104-3252	1	Housing-Upper
3	104-3253	1	Housing-Lower
4	104-2914	1	Tank-Reservoir, With Cap
5	104-3254	1	Tube
6	104-3255	2	Clamp-Miniature
7	104-3256	1	Valve-Vent, 15
8	104-3257	1	Magnet
9	104-3258	1	Holder-Magnet
10	104-3259	1	Seal-Oil
11	93-0396	1	Spring
12	104-3260	1	Shaft-Bypass
13	104-3261	1	Lever-Bypass
14	104-3262	1	Ring
15	104-3263	1	Plug-Bore
16	93-0360	1	Ring
17	104-3264	1	Pin
18	104-3265	1	Pin
19	93-0419	2	Packing
20	93-0361	1	Seal
21	93-0363	14	Screw-TAP
22	104-3266	2	Screw-TAP

--	--	--	--

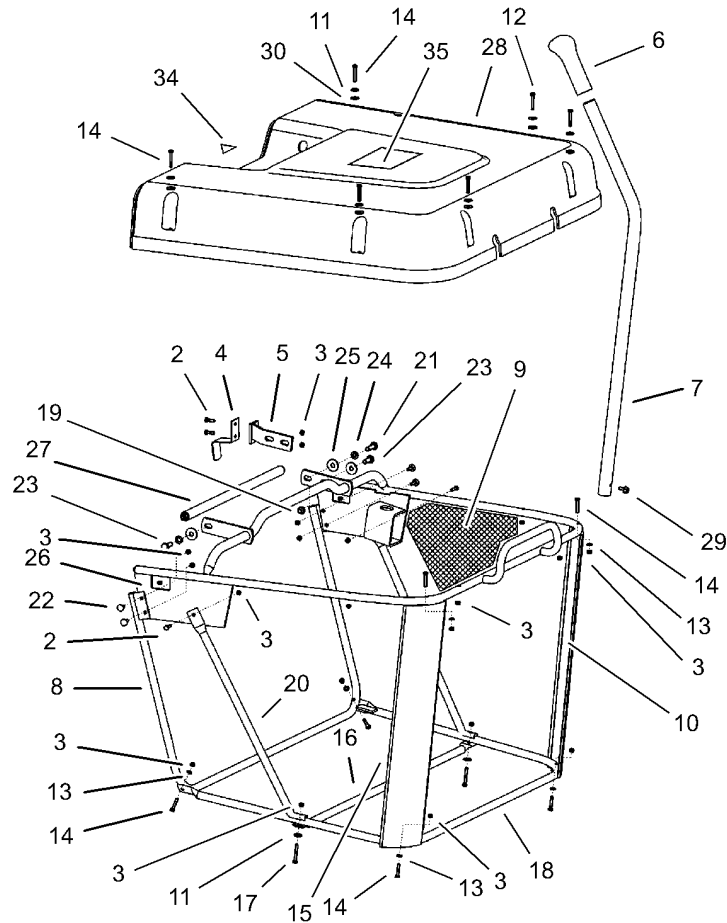

Grass Collector Assembly

Ref	Part No.	Qty.	Description
1	106-5760	1	Collector ASM
2	60-6910	2	Screw
3	87-5140	22	Nut-Lock
4	104-3033	1	Spring-Coll, Interlock Switch
5	106-5761	1	Bracket-Spring
6	104-3035	1	Grip-Handle
7	104-3036	1	Lever-Dumping
8	104-3037	1	Front Frame ASM
9	104-3038	1	Bag-Grass
10	104-3039	1	Support-Corner, Right
11	104-2943	8	Washer-Flat
12	104-2891	6	Clip-Spring
13	52-6430	14	Washer
14	104-3041	10	Screw-Hex
15	104-3042	1	Support-Corner, Left
16	104-3043	1	Brace-Connecting
17	104-3044	2	Screw-Hex
18	104-3045	1	Bottom Frame ASM
19	33024-00	1	Nut-Lock
20	104-3046	2	Brace
21	33114-025	1	Screw-HH
22	104-2948	4	Bolt-Carriage
23	33114-020	2	Screw-HH
24	42-9850	2	Washer-Lock, Spring

Ref	Part No.	Qty.	Description
25	104-2946	3	Washer-Plain
26	104-3047	1	Top Frame ASM
27	104-3048	1	Handle-Lift
28	106-5762	1	Cover-Collector
29	106-5763	1	Screw
30	104-2952	6	Washer-Rubber
34	104-3242	1	Decal-Bag To Frame
35	104-3322	1	Decal - Horsehead

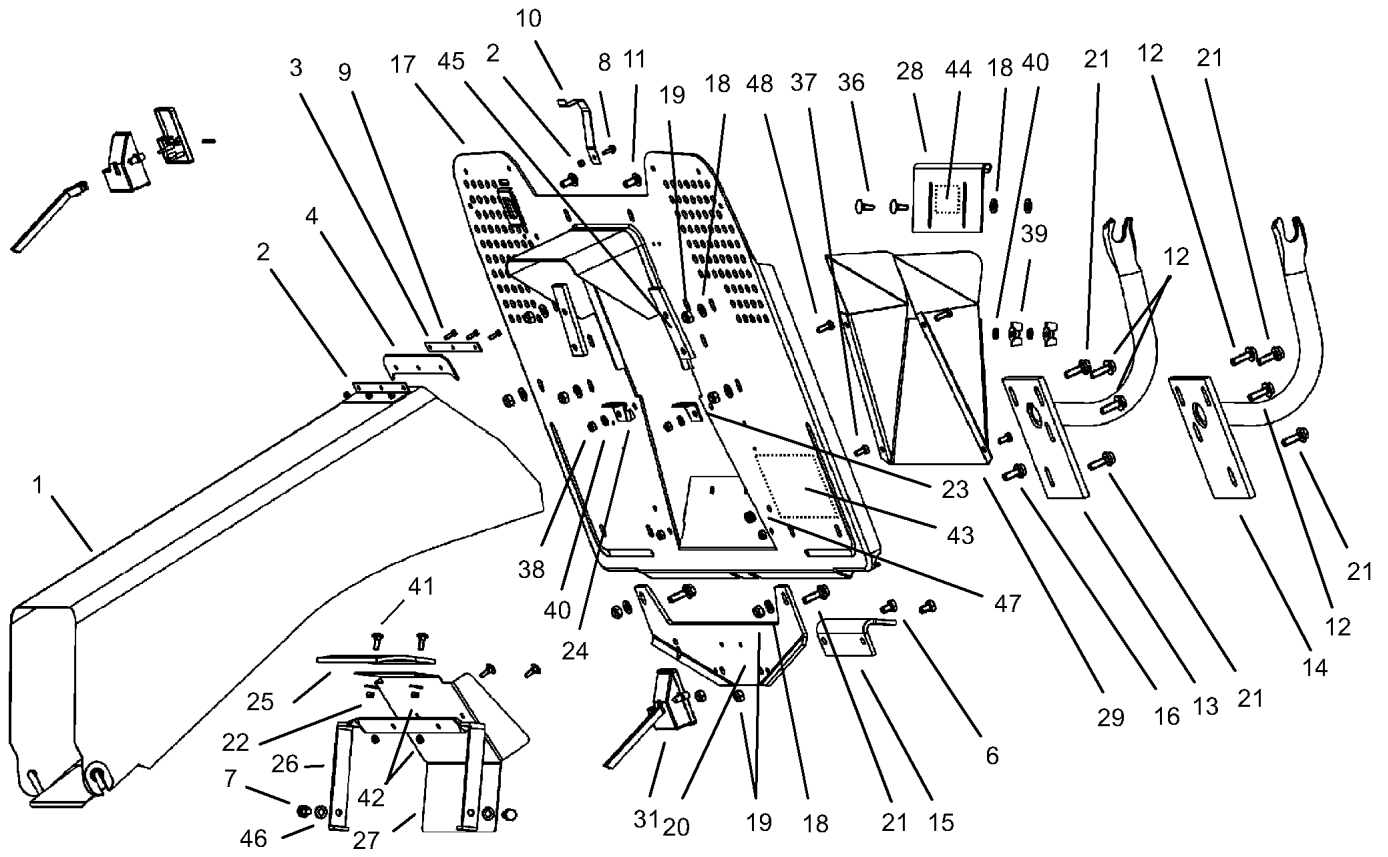

Chute Collector Assembly

Ref	Part No.	Qty.	Description
1	106-8562	1	Tunnel
2	104-2985	4	Nut-Hex
3	104-3055	1	Plate-Support
4	104-3056	1	Seal-Rubber
6	33114-020	2	Screw-HH
7	68-9410	2	Screw-Flange
8	104-2983	1	Screw
9	104-3058	3	Screw-SFH
10	104-3059	1	Cover-Switch
11	104-3060	2	Bolt-Carriage
12	104-3061	4	Screw
13	104-3062	1	Support-Collector, Right
14	104-3063	1	Support-Collector, Left
15	104-3064	1	Hitch-Tow
16	104-3065	6	Screw-Hex
17	104-3066	1	Collector Plate ASM
18	33095-00	9	Washer-Flat
19	33024-00	9	Nut-Lock
20	104-3067	1	Support-Hitch, Tow
21	104-3068	5	Screw-Hex
23	106-8597	1	Support-Tunnel, Left
24	106-8598	1	Support-Tunnel, Right
25	106-8599	1	Shield-Rubber
26	104-3069	1	Bracket-Shield, Protective

Ref	Part No.	Qty.	Description
27	104-3070	1	Shield-Protective
28	104-3336	1	Shield-Adjustable
29	104-3335	1	Hopper-Receiving
31	104-3074	1	Overload Switch ASM
36	104-2961	2	Screw
37	33113-012	2	Screw-HH
38	33023-00	4	Nut-Lock
39	32103-28	2	Nut-Wing
40	33093-00	4	Washer-Flat
41	104-2948	4	Bolt-Carriage
42	87-5140	4	Nut-Lock
43	104-3243	1	Decal-Bypass, Hydro
44	104-2853	1	Decal-Position, Bagging
45	104-3347	2	Plate-Reinforcing
46	104-3348	2	Washer-Spring
47	106-5772	1	Bushing
48	106-8575	2	Screw-HH

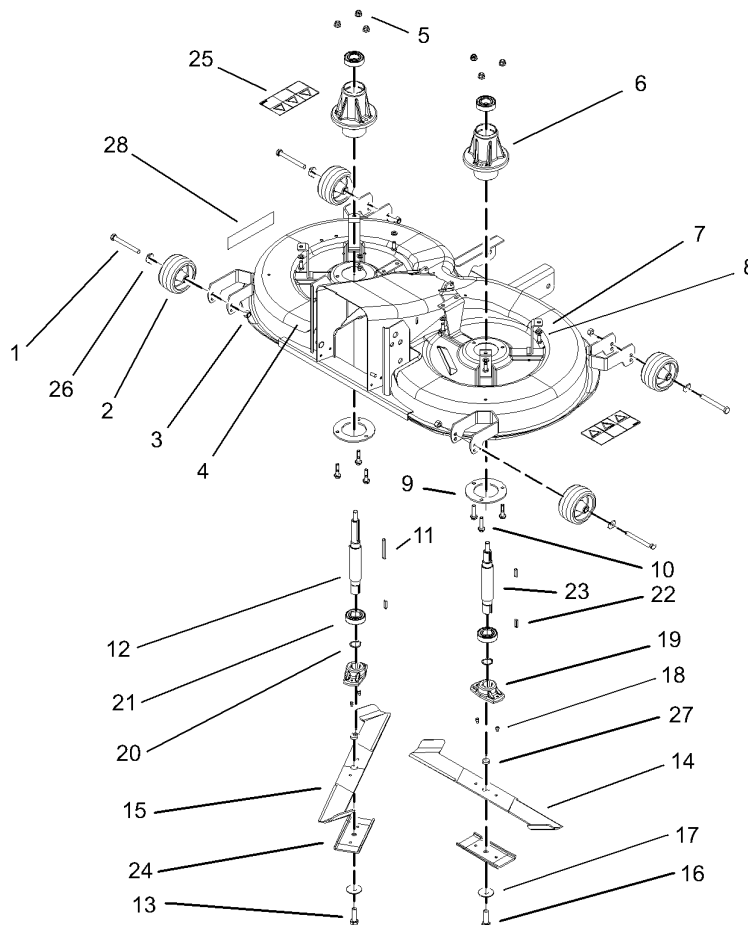

Cutting Pan, Mower Housing Assembly

Ref	Part No.	Qty.	Description
1	33115-090	4	Screw-HH
2	104-3080	4	Wheel-Gauge
3	33025-00	4	Nut-Lock
4	106-8564	1	Mower Housing ASM
5	104-3082	6	Nut-Lock, HF
6	104-3083	2	Housing-Quill
7	33094-00	8	Washer-Plain
8	33114-020	8	Screw-HH
9	104-3084	2	Support-Ring
10	104-3085	6	Bolt-HHF
11	104-3086	1	Key
12	106-8565	1	Shaft-Blade, Left
13	106-5797	1	Bolt-HH, Blade
14	106-8557	1	Blade-RH
15	106-8558	1	Blade-LH
16	106-5798	1	Bolt-Blade, HH
17	106-6532	2	Washer-Blade
18	104-3093	4	Pin-Shear, Grooved
19	106-4185	2	Adapter-Blade
20	104-3095	2	Ring-Locking
21	104-6325	4	Bearing-Ball
22	104-3097	3	Key-Square
23	106-8566	1	Shaft-Blade, Right
24	106-6533	2	Stiffener-Blade

Ref	Part No.	Qty.	Description
25	93-7824	2	Decal-Danger
26	106-5767	4	Washer
27	106-6530	2	Spacer
28	106-8563	1	Decal-Recycler

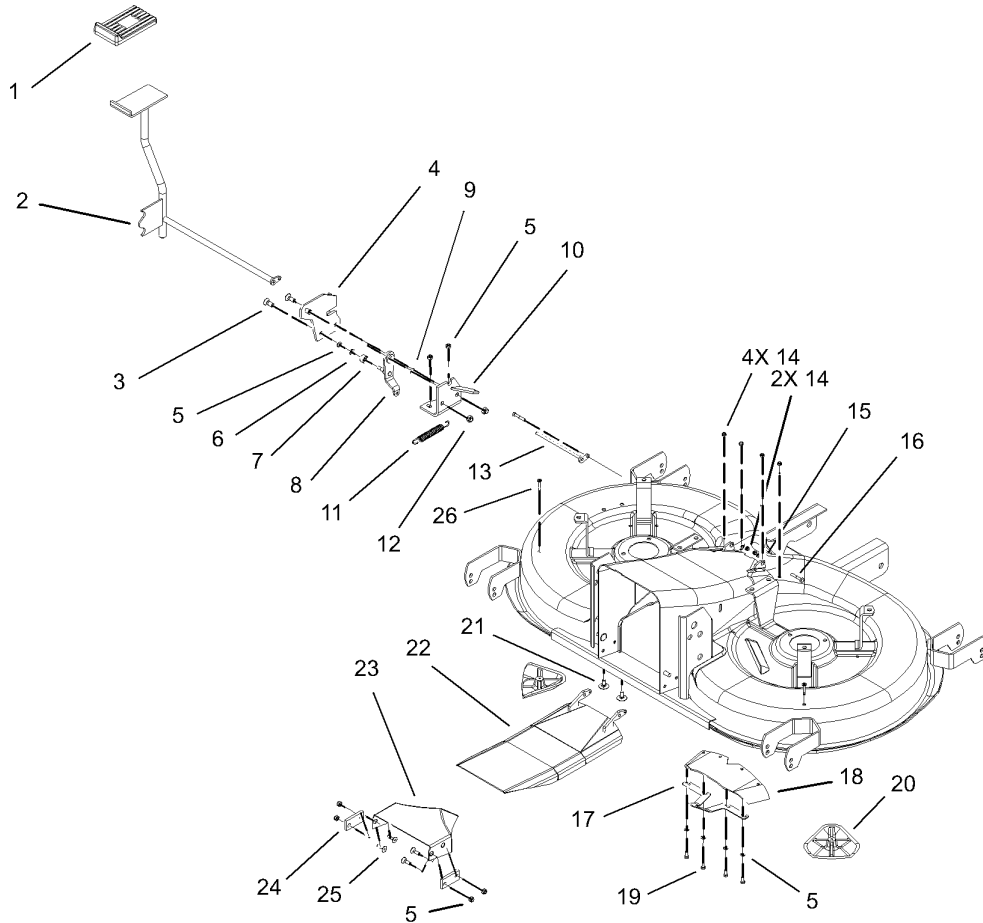

Cutting Pan-Bag on Demand Assembly

Ref	Part No.	Qty.	Description
1	106-8583	1	Cover-Lever, Foot
2	106-8582	1	Lever-Foot
3	100-8159	2	Screw-HSFH
4	106-8578	1	Plate-Stop
5	33023-00	7	Nut-Lock
6	33093-00	1	Washer-Flat
7	106-8581	1	Roller
8	106-8579	1	Lever-Spring
9	106-8592	1	Ring-Locking
10	106-8577	1	Bracket-Mounting
11	106-8580	1	Spring
12	48-9510	2	Nut
13	106-8585	1	Rod-Door, Mulch
14	87-5140	6	Nut-Lock
15	52-6430	6	Washer
16	87-5150	2	Bolt
17	106-8567	2	Guide
18	106-8586	1	Gasket-Door, Mulch
19	106-8575	4	Screw-HH
20	106-8587	1	Kicker
21	33123-016	2	Screw-CARR
22	106-8584	1	Door-Mulch
23	106-8573	1	Baffle-Center
24	106-8572	2	Plate-Baffel, Center

Ref	Part No.	Qty.	Description
25	106-8574	4	Screw
26	104-1451	2	Screw-TAP, PPH

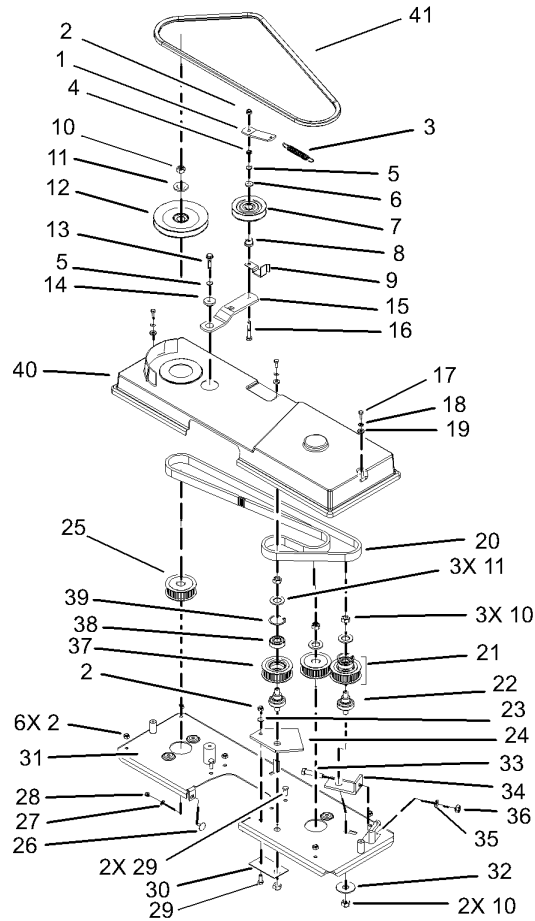

Cutting Pan Drive Assembly

Ref	Part No.	Qty.	Description
1	104-3099	1	Lever-Engagement
2	48-9510	8	Nut
3	104-3101	1	Spring
4	57-6390	1	Nut-Jam
5	42-9850	2	Washer-Lock, Spring
6	106-8588	1	Washer-Flat
7	104-3103	1	Pulley-Idler
8	104-3104	1	Bushing
9	104-3105	1	Retainer-Belt
10	48-9540	6	Nut-Lock, Hex NI
11	33099-00	4	Washer-Flat
12	104-3107	1	Pulley-Drive
13	104-3085	1	Bolt-HHF
14	104-3108	1	Spacer-Shoulder
15	104-3109	1	Arm-Idler
16	33114-050	1	Screw-HH
17	33113-016	3	Screw-HH
18	106-8568	3	Washer-Flat
19	83-7420	3	Washer-Rubber
20	106-8591	1	Belt-Cog
21	104-3113	2	Cog Pulley ASM
22	104-3114	2	Pin-Pulley, Cog
23	33094-00	1	Washer-Plain
24	104-3115	1	Support-Pulley

Ref	Part No.	Qty.	Description
25	104-3116	2	Pulley-Cog, Drive
26	33123-016	2	Screw-CARR
27	33093-00	2	Washer-Flat
28	33023-00	2	Nut-Lock
29	33114-025	3	Screw-HH
30	104-3117	1	Plate-Anchor
31	106-8590	1	Blade-Drive Plate
32	104-2909	1	Washer
33	33115-050	1	Screw-HH
34	104-3120	1	Bracket-Idler
35	33095-00	1	Washer-Flat
36	48-9520	1	Nut
37	104-3121	1	Pulley-Cog
38	100-1048	1	Bearing-Ball
39	104-3123	1	Ring-Locking
40	106-8589	1	Belt-Cover
41	104-3126	1	V-Belt

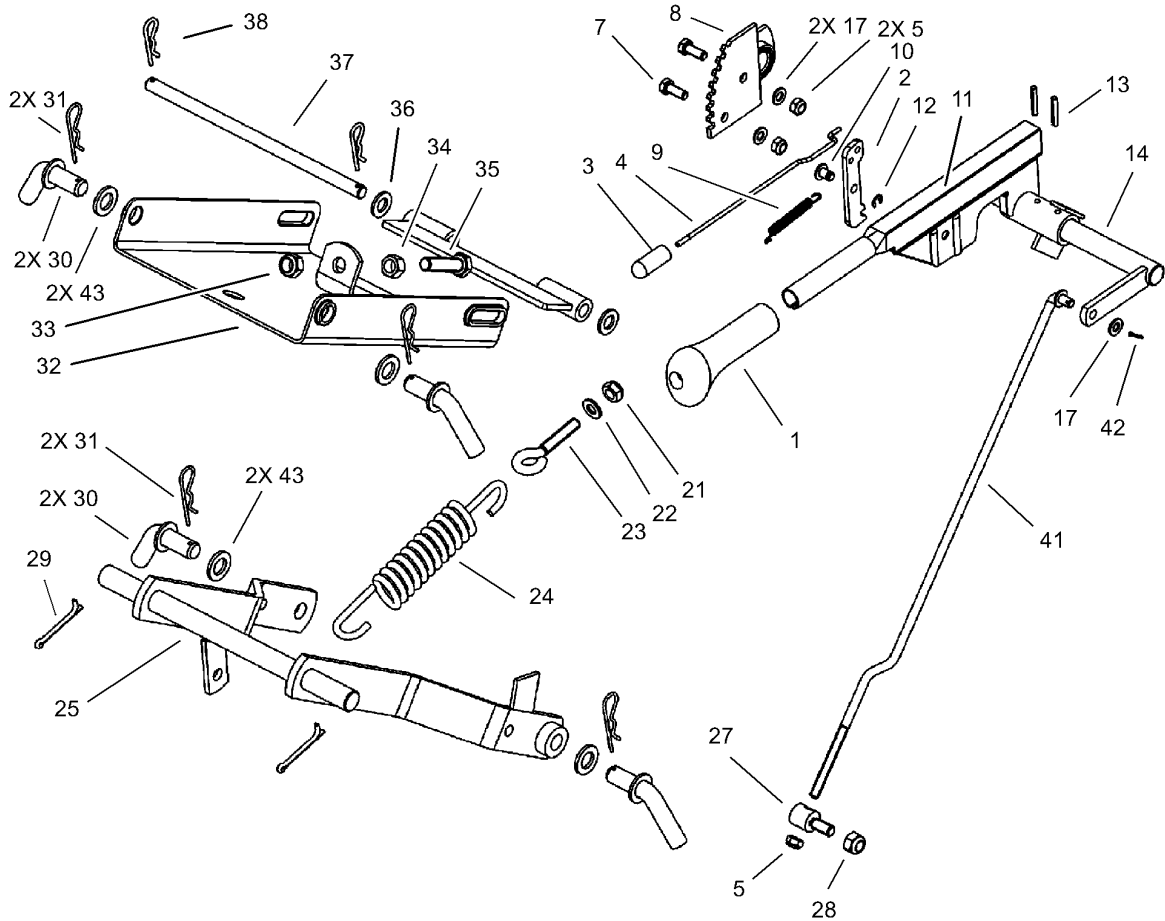

Operation Mower Lift Assembly

Ref	Part No.	Qty.	Description
1	104-3129	1	Grip-Handle
2	104-3130	1	Ratchet-Plate, Pivot
3	104-3131	1	Button-Plunger
4	104-3132	1	Rod-Connection
5	33024-00	3	Nut-Lock
7	33114-020	2	Screw-HH
8	104-3133	1	Segment-Gear
9	104-3134	1	Spring
10	104-3135	1	Pin-Arm Lever
11	104-3136	1	Lever-Arm, Height Adj.
12	104-3137	1	Clip-Pin
13	104-2994	2	Pin-Spring
14	104-3138	1	Shaft-Height Adj.
17	33094-00	3	Washer-Plain
21	33025-00	1	Nut-Lock
22	33095-00	1	Washer-Flat
23	104-3139	1	Bolt-Eye
24	104-3140	1	Spring-Lift
25	104-3141	1	Pivot Arm ASM
27	104-3142	1	Pin-Lifting
28	33025-00	1	Nut-Lock
29	104-3016	2	Pin-Cotter
30	104-3143	4	Pin-Bent
31	104-3144	4	Pin-Hair

Ref	Part No.	Qty.	Description
32	104-3145	1	Suspension-Mower Deck, Front
33	33026-00	1	Nut-Lock
34	33016-00	1	Nut-Hex
35	104-3146	1	Holder-Front
36	104-3124	2	Washer-Flat
37	104-3147	1	Pin
38	104-3148	2	Clip-Hair Pin
41	104-3149	1	Rod-Height Adj.
42	104-3151	1	Pin-Cotter
43	34-9270	4	Washer-Hose

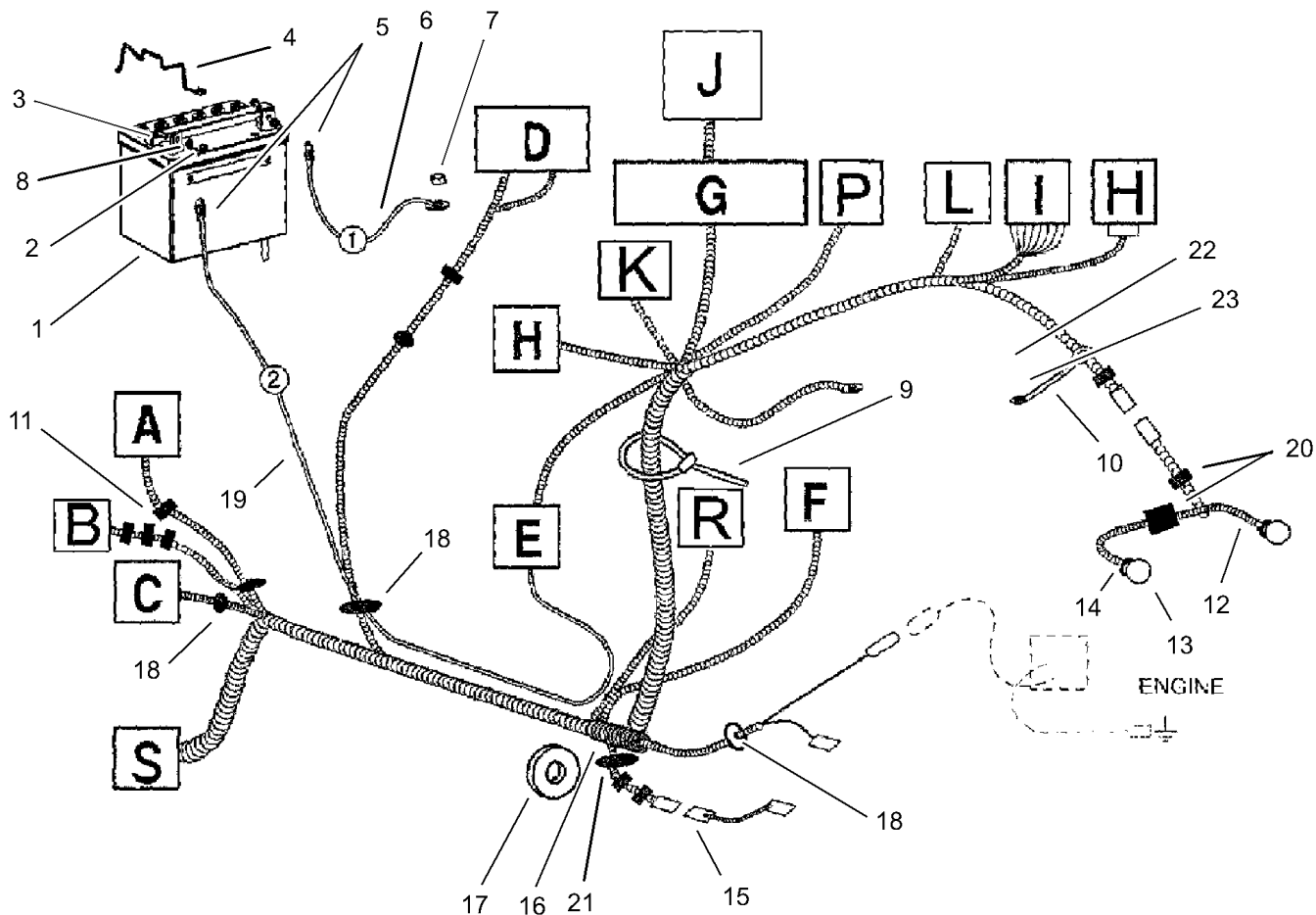

Electrical Wiring Harness Assembly

Ref	Part No.	Qty.	Description
1	104-3152	1	Battery-12V
2	33013-00	2	Nut-Hex
3	33113-016	2	Screw-HH
4	104-3153	1	Clamp-Battery
5	104-3154	2	Boot-Rubber
6	104-3155	1	Cable-Battery, Negative
7	33024-00	1	Nut-Lock
8	33093-00	2	Washer-Flat
9	3334-945	3	Tie-Cable
10	104-3156	1	Holder- Harness, Wiring
11	104-3157	10	Clip-Snap
12	88-4320	1	Harness-Wire, Lights
13	104-3158	2	Bulb-Light
14	104-3159	2	Socket-Light
15	104-3160	1	Harness-Clutch
16	104-3340	1	Harness-Wiring,
17	104-3163	1	Cap
18	104-3165	3	Bushing
19	104-3166	1	Cable-Battery Positive
20	104-3167	2	Clip-Nylon
21	104-3168	1	Bushing
22	33114-020	1	Screw-HH
23	104-2946	1	Washer-Plain

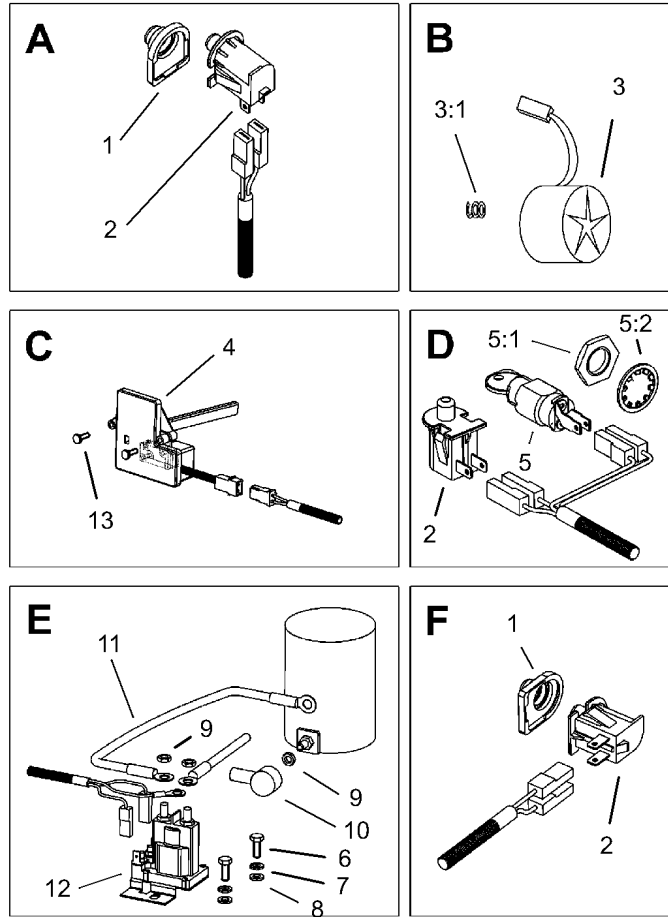

Electrical Switch Assembly

Ref	Part No.	Qty.	Description
1	104-3178	2	Cover-Protective
2	104-3179	3	Switch-Delta
3	99-8090	1	Magnet ASM
3:1	93-6601	1	Spring-Compression
4	104-3185	1	Switch-Omron
5	46-5780	1	Switch-Starter
5:1	3254-5	1	Washer-Tooth
5:2	218-461	1	Nut-HH
6	33113-012	2	Screw-HH
7	104-3186	2	Washer-Spring
8	33093-00	2	Washer-Flat
9	32128-32	1	Nut-HHF
10	104-3187	1	Boot-Rubber
11	104-3188	1	Lead-Starter, Electric
12	104-3189	1	Solenoid
13	104-3349	2	Screw

--	--	--	--

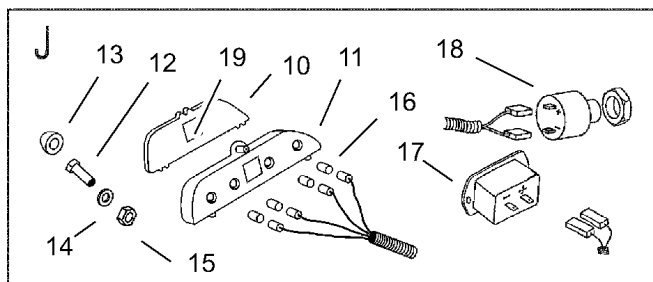
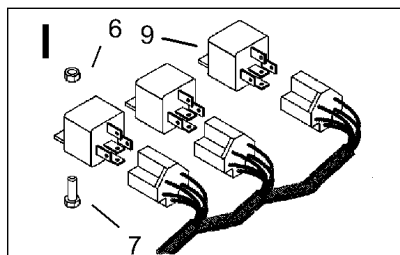
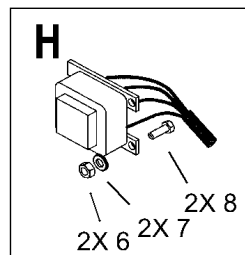
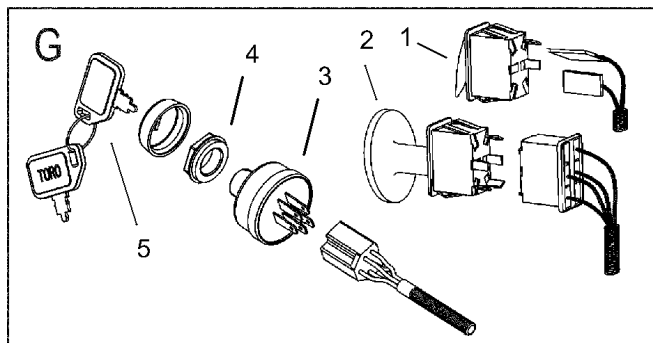

Electrical Switch Assembly (continued)

Ref	Part No.	Qty.	Description
1	93-0527	1	Switch-Cruise
2	93-9998	1	Switch-PTO
3	92-6785	1	Switch-Ignition
4	104-3172	1	Nut-Hex
5	62-7770	2	Key-Ignition
6	87-5140	3	Nut-Lock
7	104-2943	3	Washer-Flat
8	104-2978	2	Screw-Hex
9	104-3173	3	Relay
10	92-6705	1	Lens-Dash
11	92-6732	1	Housing-Light, Indicator
12	104-3191	3	Screw
13	104-3174	3	Screw-Cap
14	104-3175	3	Washer
15	104-2985	3	Nut-Hex
16	104-3176	4	Bulb
17	104-3177	1	Buzzer
18	94-4208	1	Hourmeter
19	104-2854	1	Decal-Dash

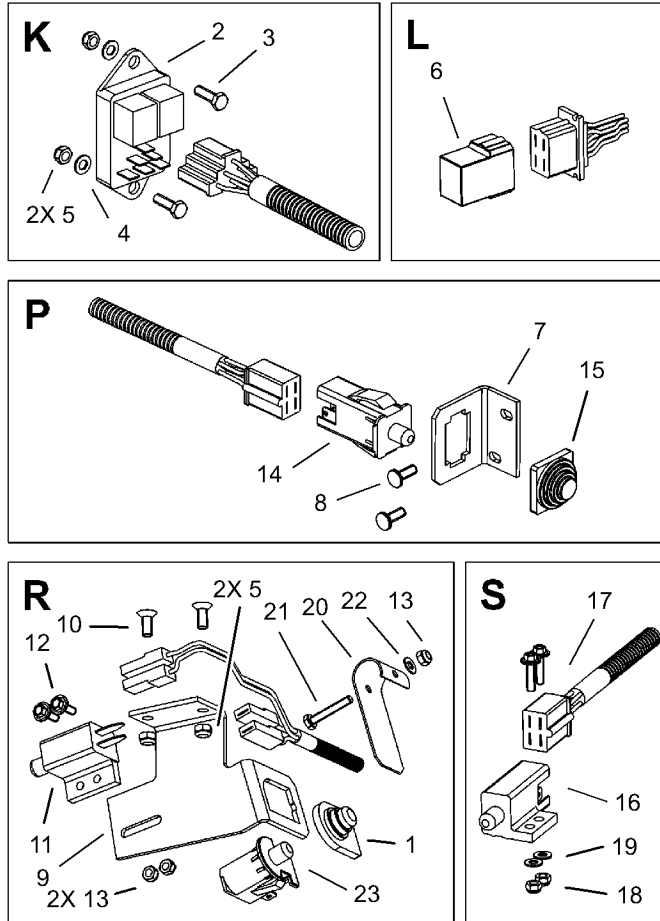

Electrical Switch Assembly (continued)

Ref	Part No.	Qty.	Description
1	104-3178	1	Cover-Protective
2	99-3701	1	Module-Clutch
3	60-6910	2	Screw
4	52-6430	2	Washer
5	87-5140	4	Nut-Lock
6	104-3169	1	Circuit-Memory
7	104-3333	1	Holder-Switch
8	104-3190	2	Screw
9	104-3332	1	Holder-Switch
10	104-2980	2	Screw
11	95-1653	1	Switch-Pole, Single
12	104-2983	2	Screw
13	104-2985	3	Nut-Hex
14	104-3338	1	Switch-Delta
15	104-3339	1	Cover-Switch
16	104-3330	1	Switch-Delta
17	104-3331	2	Bolt
18	46-0430	2	Nut-Lock
19	52-6430	2	Washer
20	106-5765	1	Lever-Spring
21	104-3009	1	Screw-Hex
22	106-5766	1	Washer
23	104-3179	1	Switch-Delta

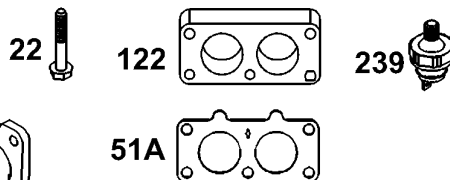
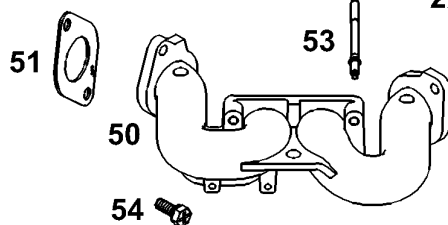
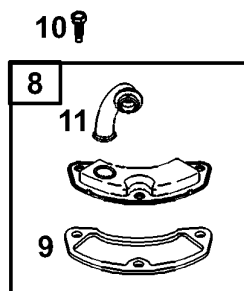
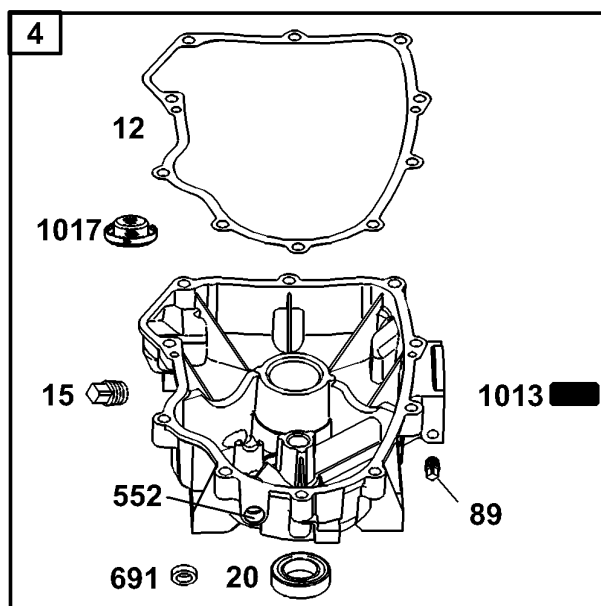
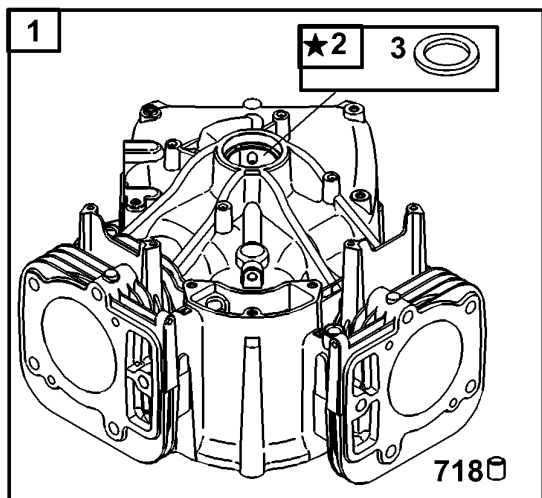

★ REQUIRES SPECIAL TOOLS TO INSTALL. SEE REPAIR INSTRUCTION MANUAL.

1058 OWNER'S MANUAL

Assemblies include all parts shown in frames.

Cylinder Assembly Briggs and Stratton 406777-0157-E1

Ref	Part No.	Qty.	Description
1	690231	1	Cylinder Assembly
2	499585	1	Bushing And Seal Kit
3	391086	1	Seal-Oil
4	690069	1	Sump-Engine
8	499601	1	Breather ASM
9	273370	1	Gasket-Breather
10	690960	1	Screw
11	690942	1	Tube-Breather
12	273488	1	Gasket-Crankcase
15	94239	1	Plug-Pipe
20	690947	1	Seal-Oil
22	690308	1	Screw (Crankcase Cover/Sump)
50	690948	1	Manifold-Intake
51	273487	1	Gasket-Intake
51A	690950	1	Gasket-Intake
53	690951	1	Stud
54	94913	1	Screw-Torx Hex
89	690283	1	Plug-Oil
122	690952	1	Spacer-Carburetor
239	491657	1	Switch-Oil Pressure
250	690957	1	Retainer-Breather
252	690956	1	Collector-Oil

Ref	Part No.	Qty.	Description
552	690552	1	Bushing-Crank, Governor
654	94010	1	Nut
691	690657	1	Seal-Shaft, Governor
718	230192	1	Pin-Dowel
1013	690954	1	Nipple-Filter, Oil
1017	690770	1	Screen-Pump, Oil
1058	274277	1	Owner-S Manual

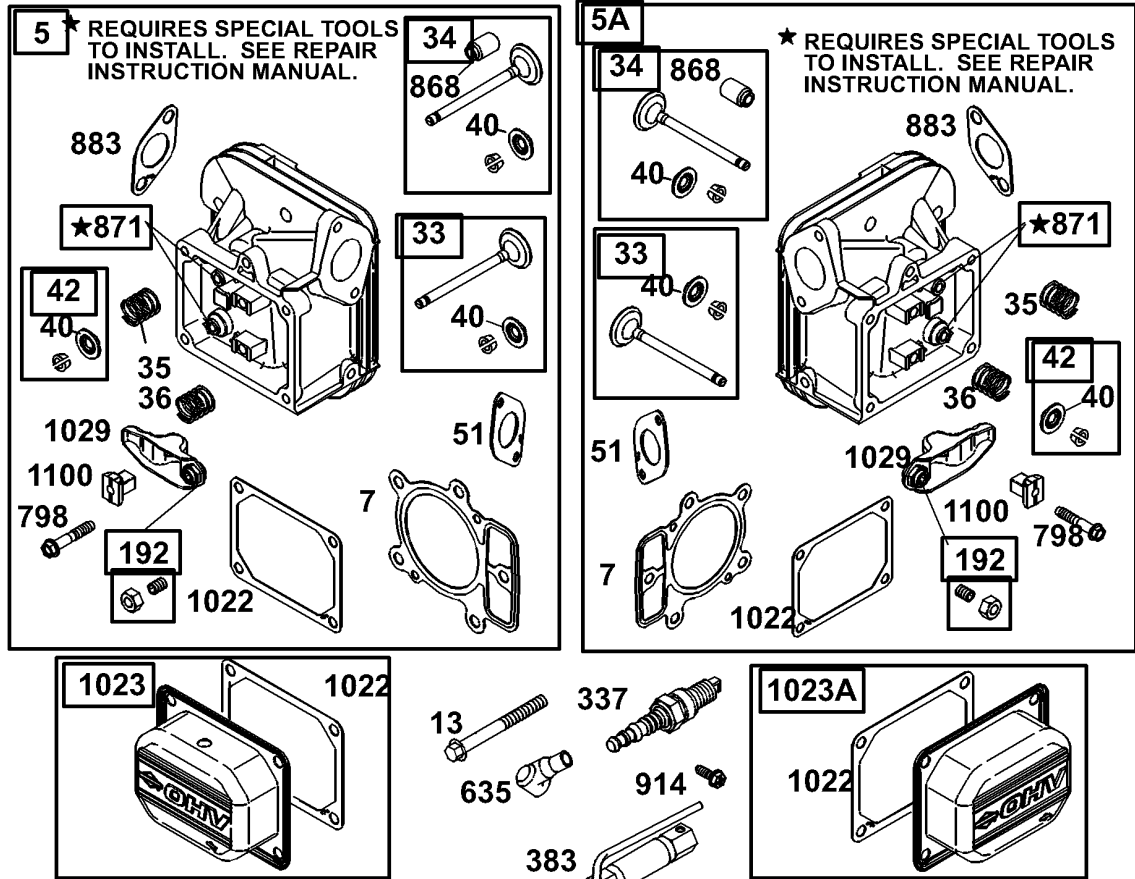

Assemblies include all parts shown in frames.

Cylinder Head Assembly Engine Briggs and Stratton Model 406777-0157-E1

Ref	Part No.	Qty.	Description
5	499587	1	Head-Cylinder(Cylinder #1)
5A	499595	1	Head-Cylinder (Cylinder #2)
57	690962	1	Gasket-Head, Cylinder
13	690360	1	Screw
33	499596	1	Valve-Exhaust
34	499597	1	Valve-Intake
35	690963	1	Spring-Valve
36	690963	1	Spring-Valve
40	263215	1	Retainer-Valve
42	499586	1	Keeper-Valve
51	273487	1	Gasket-Intake
192	690083	1	Adjuster-Arm, Rocker
337	691043	1	Spark Plug
383	19374	1	Wrench-Spark Plug
635	66538	0	Boot-Plug, Spark
798	690967	1	Screw (Rocker Arm)
868	690968	1	Seal-Valve
871	690969	1	Bushing-Valve Guide
883	690970	1	Gasket-Exhaust
914	690960	1	Screw
1022	273486	1	Gasket-Rocker Cover
1023	499599	1	Cover-Rocker
1023A	499600	1	Cover-Arm, Rocker

Ref	Part No.	Qty.	Description
1029	690972	1	Arm-Rocker
1100	690973	1	Pivot-Arm, Rocker

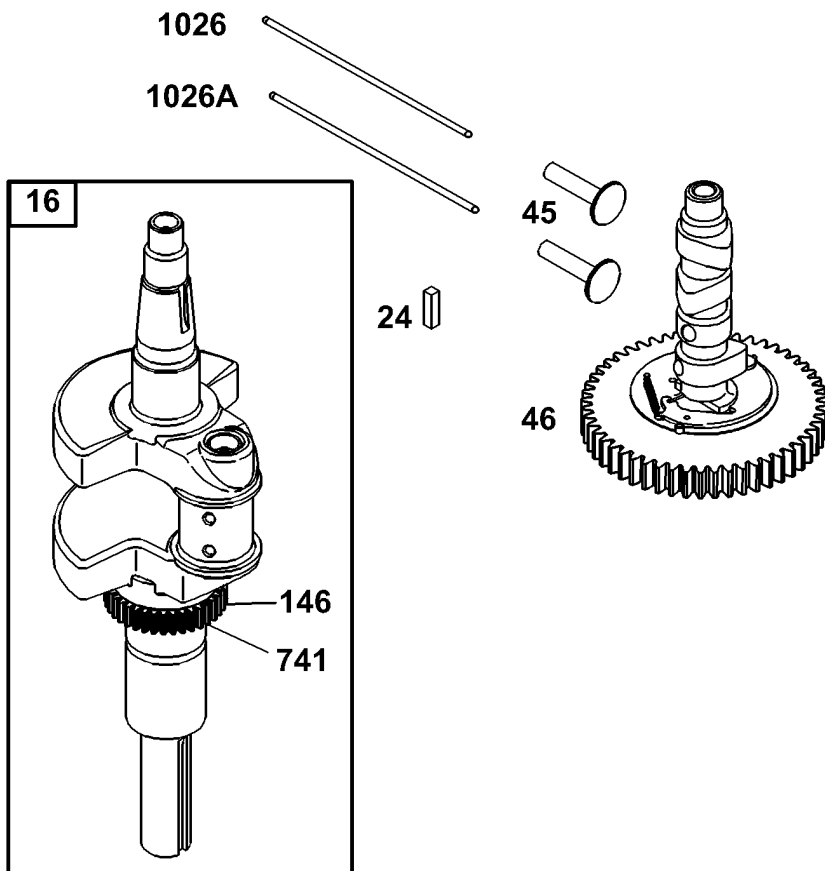
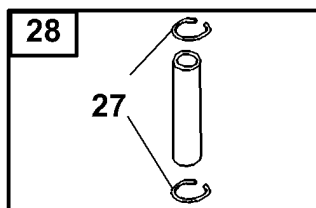
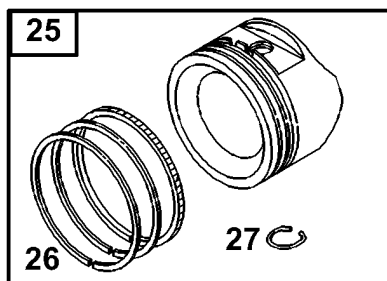
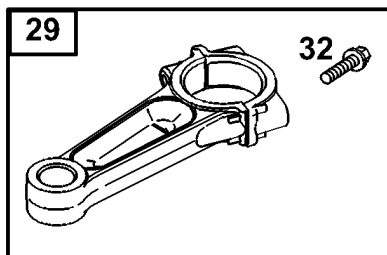

Assemblies include all parts shown in frames.

Crankshaft Assembly Engine Briggs and Stratton Model 406770-0157-E1

Ref	Part No.	Qty.	Description
16	691046	1	Crankshaft
24	222698	1	Key
25	499588	1	Piston ASM (Standard)
	499589	1	Piston Assembly (.010 Oversize)
	499590	1	Piston ASM (.020In Oversize)
	499591	1	Piston Assembly (.030 Oversize)
26	499604	1	Ring Set (Standard)
	499605	1	Ring Set (.010 Oversize)(Connecting Rod)
45	262679	1	Tappet-Valve
46	690978	1	Camshaft
146	94388	1	Key-Timing
741	690980	1	Gear-Timing
1026	690981	1	Rod-Push (Steel)
1026A	690982	1	Rod-Push (Aluminum)

--	--	--	--

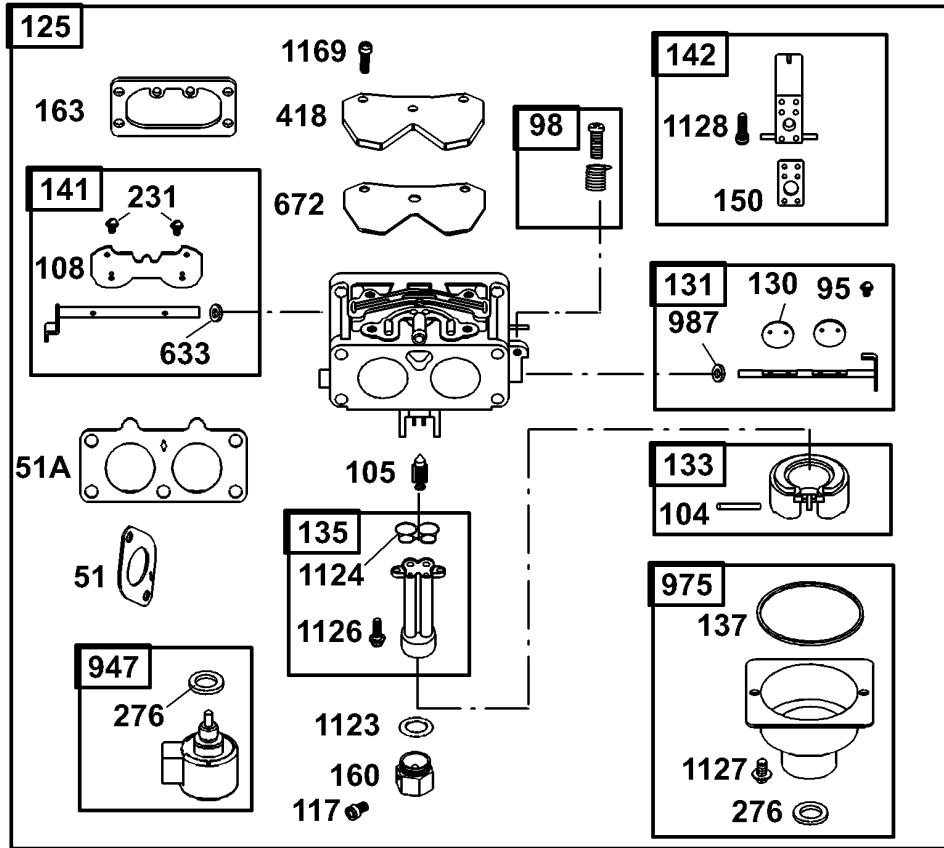

Assemblies include all parts shown in frames.

Carburetor Assembly Briggs and Stratton 406777-0157-E1

Ref	Part No.	Qty.	Description
3 5 51	273487	1	Gasket-Intake
3 4 51A	690950	1	Gasket-Intake
6 95	690718	1	Screw
98	499802	1	Idle Speed Kit
4 104	690984	1	Guard-Muffler
4 105	690985	1	Valve-Float, Needle
108	690986	1	Valve-Choke
4 117	690232	1	Jet-Main
	690989	1	Jet-Main(High Altitude)
125	499804	1	Carburetor
130	690993	1	Valve-Throttle
131	499805	1	Throttle Shaft Kit
133	499806	1	Float-Carburetor
135	499803	1	Tube-Fuel Transfer
4 6 137	690994	1	Gasket-Bowl, Float
141	499807	1	Kit-Choke Shaft
142	D499808	1	Nozzle-Carburetor
4 6 150	690995	1	Gasket-Nozzle
160	690996	1	Retainer-Solenoid
3 4 163	273640	1	Gasket-Air Cleaner
231	690718	1	Screw
3 4 276	690997	1	Washer-Sealing
6			

Ref	Part No.	Qty.	Description
418	690999	1	Plate-Cover, Carburetor
4 6 633	690998	1	Seal-Shaft, Choke
4 6 672	690234	1	Gasket-Cover Plate, Carburetor
947	499809	1	Solenoid-Fuel
975	499810	1	Bowl-Float
4 6 987	691000	1	Seal-Shaft, Throttle
4 6 1123	690987	1	O-Ring Seal (Solenoid Retainer)
4 6 1124	690988	1	Seal-O Ring
1126	690991	1	Screw
1127	690992	1	Screw (Float Bowl)
4 1128	690990	1	Screw
4 1169	690990	1	Screw

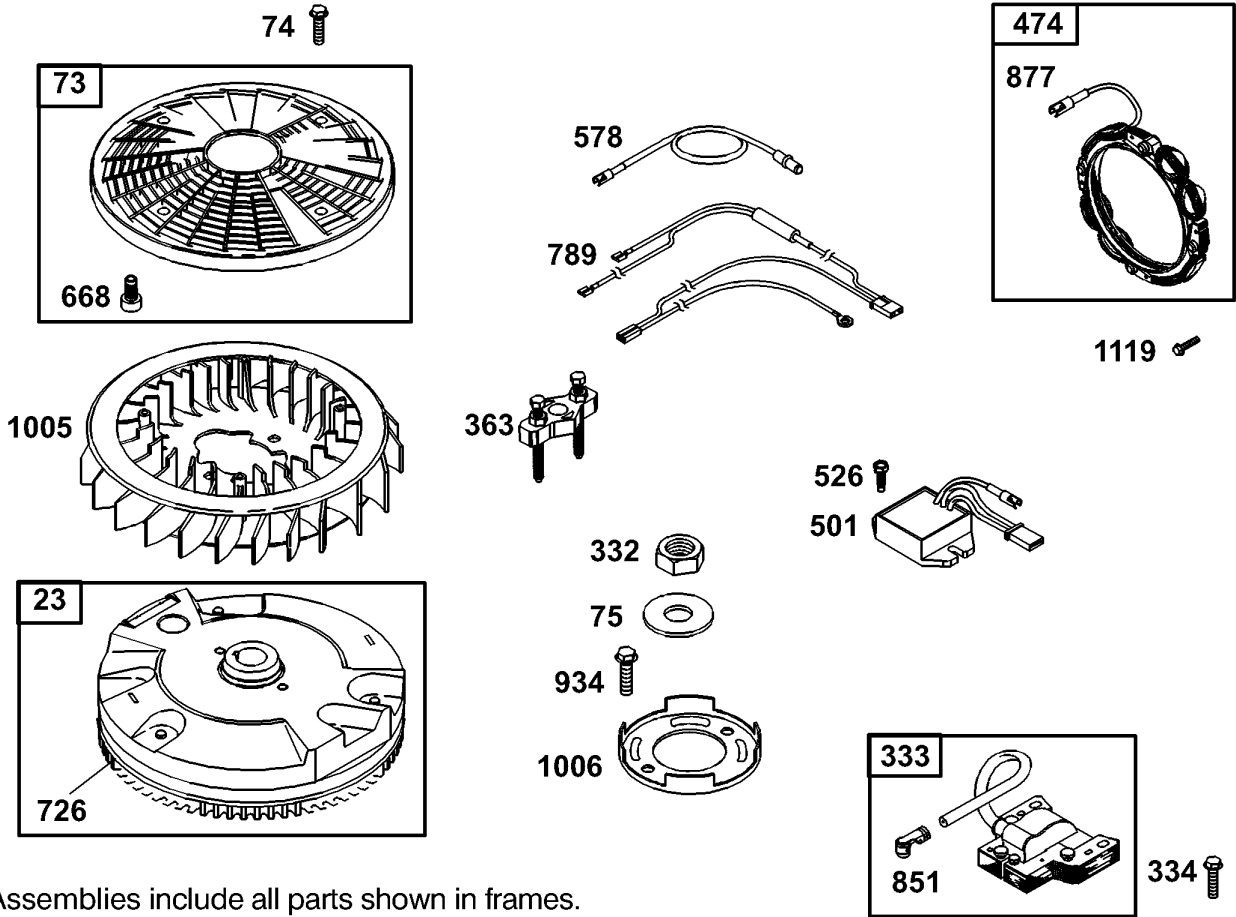

Assemblies include all parts shown in frames.

Flywheel Assembly Briggs and Stratton 406777-0157-E1

Ref	Part No.	Qty.	Description
23	691053	1	Flywheel
73	691055	1	Screen-Rotating
74	691057	1	Screw (Rotating Screen)
75	691056	1	Washer
332	230674	1	Nut-Hex
333	691060	1	Armature-Magneto
334	691061	1	Screw
363	691062	1	Puller-Flywheel
474	392595	1	Alternator
501	491546	1	Regulator
526	691129	1	Screw
578	691208	1	Wire ASM
668	691215	1	Spacer
726	499612	1	Gear-Ring
789	691220	1	Harness-Wiring
851	493880	1	Terminal-Spark Plug
877	393537	1	Connector-Wire, Tri Circuit
934	94627	1	Screw
1005	691243	1	Fan-Flywheel
1006	691247	1	Retainer-Fan
1119	93621	1	Screw

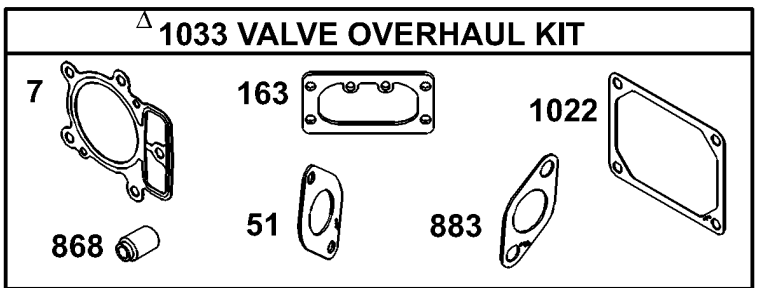
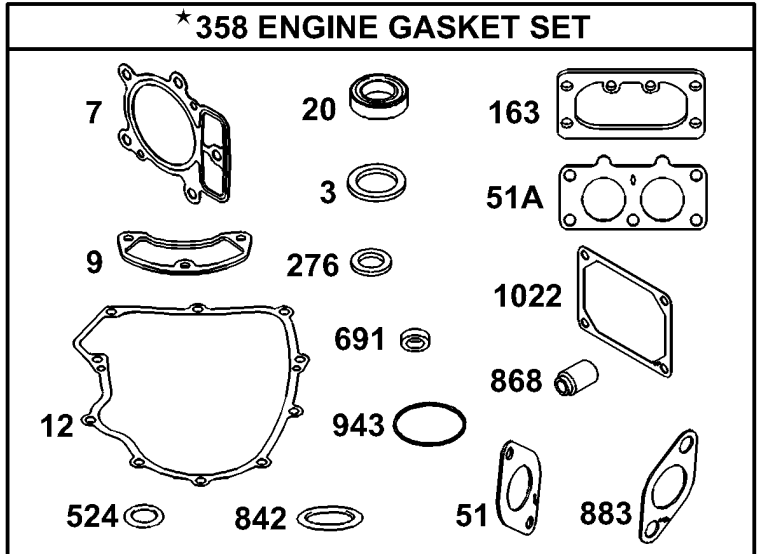
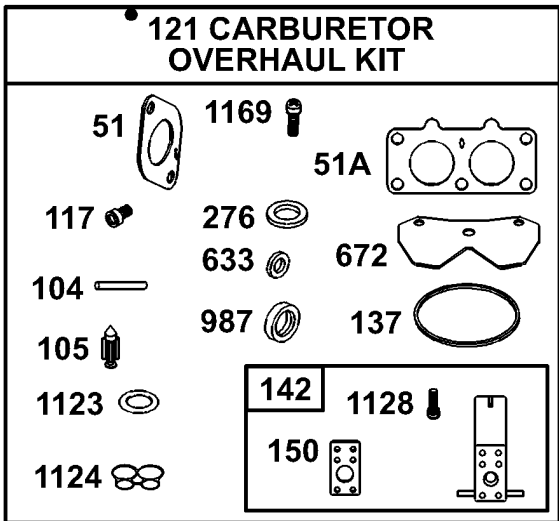
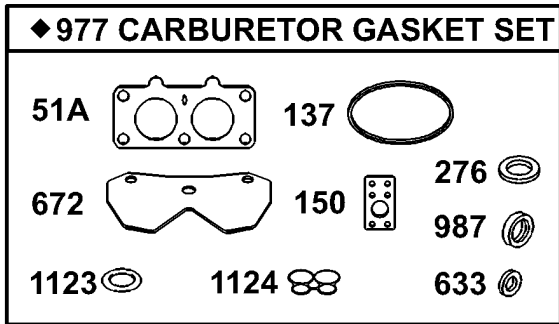

Assemblies include all parts shown in frames.

Carburetor Overhaul Kit Assembly Briggs and Stratton 406777-0157-E1

Ref	Part No.	Qty.	Description
3	391086	1	Seal-Oil
57	690962	1	Gasket-Head, Cylinder
9	273370	1	Gasket-Breather
12	273488	1	Gasket-Crankcase
20	690947	1	Seal-Oil
451	273487	1	Gasket-Intake
451A	690950	1	Gasket-Intake
104	690984	1	Guard-Muffler
105	690985	1	Valve-Float, Needle
117	690232	1	Jet-Main
121	499811	1	Carburetor Overhaul Kit
6137	690994	1	Gasket-Bowl, Float
142	499808	1	Nozzle-Carburetor
6150	690995	1	Gasket-Nozzle
5163	273640	1	Gasket-Air Cleaner
4276	690997	1	Washer-Sealing
358	499889	1	Engine Gasket Set
524	691032	1	Seal-O Ring
633	690998	1	Seal-Shaft, Choke
672	690234	1	Gasket-Cover Plate, Carburetor
691	690657	1	Seal-Shaft, Governor
842	280393	1	O-Ring Seal

Ref	Part No.	Qty.	Description
5868	690968	1	Seal-Valve
5883	690970	1	Gasket-Exhaust
943	690589	1	Seal-O Ring
977	499812	1	Carburetor Gasket Set
987	691000	1	Seal-Shaft, Throttle
51022	273486	1	Gasket-Rocker Cover
1033	499890	1	Valve Overhaul Kit
61123	690987	1	O-Ring Seal (Solenoid Retainer)
61124	690988	1	Seal-O Ring
1128	690990	1	Screw
1169	690990	1	Screw

NOTES

NOTES

NOTES

