

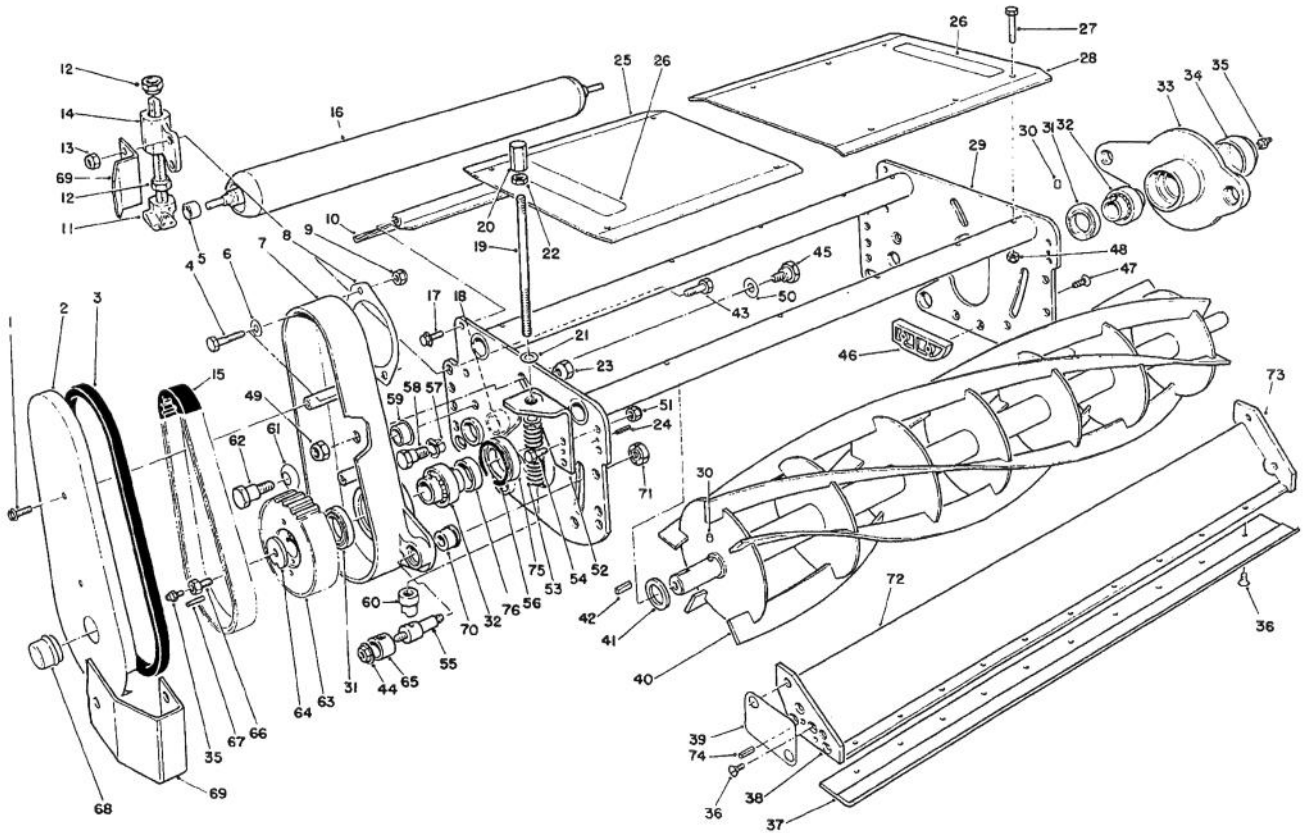

MODEL NO. 03753-50001 & UP MODEL NO. 03756-50001 & UP MODEL NO. 03751-50001 & UP MODEL NO. 03752-50001 & UP MODEL NO. 03754-50001 & UP MODEL NO. 03741-50001 & UP	<b>PARTS CATALOG</b>
<b>5, 7 &amp; 11 BLADE CUTTING UNITS</b> For Reelmaster 335D, 450D & 4500D	



T-0178A

## CUTTING UNIT ASSEMBLY – R.H. & CENTER

Ref. No.	Part No.	Description	No. Used	Ref. No.	Part No.	Description	No. Used
1	3234-14	Screw – Flange Hd.	2	18	62-6110	Assembly – Bushing	4
2	75-7580	Cover – Drive Housing R.H.	1	19	72-0390	Rod – Bedknife, Adj.	2
3	47-7170	Gasket	1	20	72-0380	Knob – Hex.	2
4	324-6	Bolt	2	21	257-5	Washer – Thrust	4
5	59-5780	Bushing – Roller	2	22	3218-5	Nut – Jam	2
6	3256-25	Washer – Flat	1	23	242-50	Nut – Cone	2
7	92-6098	Housing – Drive, R.H.	1	24	32121-2	Pin – Roll	2
8	48-9050	Plate – Shield, Drive	1	25	59-5840	Cover – Outboard	1
9	3296-48	Nut – Lock	2	26	76-8760	Decal	2
10	75-7680	Deflector – Grass	1	27	3234-34	Screw	10
11	84-6100	Assembly – Collar	2	28	59-5830	Cover – Inboard	1
12	59-5820	Nut – Cone	4	29	14-0829	Frame (Incl. Ref. #18)	1
13	3296-25	Nut – Lock	4	30	48-8880	Pin – Dowel	1
14	59-5770	Housing – Roller, Adj.	2	31	93-1414	Seal	2
15	47-7160	Belt	1	32	59-6140	Bearing	2
16	59-5630	Assembly – Roller, Rear	1	33	59-5550	Housing – Bearing	1
17	3234-12	Screw – Flange Hd.	2				

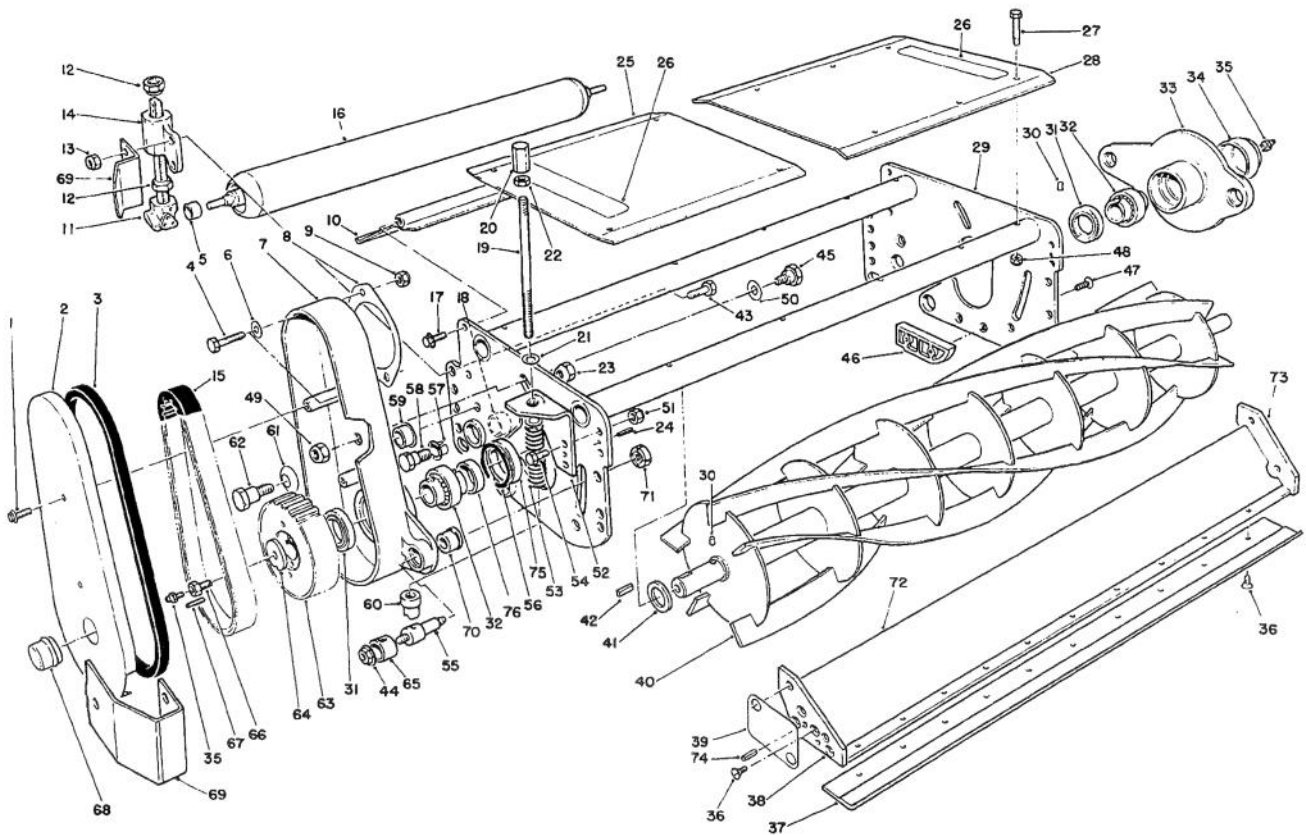

T-0178A

## CUTTING UNIT ASSEMBLY – R.H. & CENTER (Continued)

Ref. No.	Part No.	Description	No. Used
34	59-5560	Cap - Dust	1
35	302-5	Fitting - Grease	2
36	57-4910	Screw (5 & 7 Blade)	10
36	57-4910	Screw (11 Blade)	19
37	59-5890	Bedknife (7 Blade)	1
*	72-0480	Bedknife (5 Blade)	1
*	76-3620	Bedknife (11 Blade)	1
38	76-3610	Plate - End, R.H. (11 Blade)	1
39	76-3580	Spacer	2
40	14-7419	Reel (5-Blade)	1
*	13-8219	Reel (7-Blade)	1
*	14-0919	Reel (11-Blade)	1
41	38-7330	Shield - Grass	2
42	75-7570	Key - Rectangular	1
43	325-7	Screw - Cap Hex. Hd.	4
44	32128-15	Nut - Flange	2
45	62-6080	Bolt - Shoulder	2
46	77-4810	Block - Deflector	2
47	32108-101	Screw - Flat Hd. (7 & 11 Blade)	4
48	3296-42	Nut - Lock	10
49	3296-28	Nut - Lock	1
50	3256-69	Washer - Flat	1
51	3296-26	Nut - Lock	4
52	72-0460	Bracket - L.H. Bedknife Adj.	1
*	72-0450	Bracket - R.H. Bedknife Adj.	1
53	92-9231	Spring	2
54	323-7	Screw - Cap Hex. Hd.	4

Ref. No.	Part No.	Description	No. Used
55	72-0440	Pin - Pivot	2
56	32151-71	Ring - Retaining	1
57	256-292	Bushing - Nylon	4
58	84-6090	Bolt - Shoulder	4
59	256-252	Bushing - Flange	2
60	72-0410	Stand Off	2
61	3290-440	Washer - Belleville	2
62	48-9020	Bolt	2
63	47-7140	Pulley - Driven	1
64	59-6150	Washer - Pulley	1
65	72-0420	Clamp Tube	2
66	59-6190	Screw - Cap, Reel	1
67	32121-50	Pin - Roll	1
68	59-7490	Plug - Grease Fitting	1
69	72-0470	Guard	2
70	92-9252	Bushing - Flange	2
71	82-9390	Nut - Special	2
72	59-5470	Bedbar, Welded Assembly (5 & 7 Blade)	1
*72	77-4340	Bedbar (11 Blade)	1
73	76-3600	Plate - End, L.H. (11 Blade)	1
74	32121-11	Pin - Roll	4
75	92-9250	Seal - Grease	1
76	92-9251	Sleeve - Wear	1
*	14-2099	Kit - Overhaul (Incl. Ref. #18, 30-32, 36, 39, 42, 56, 57, 59 & 70)	1

\*Not Illustrated

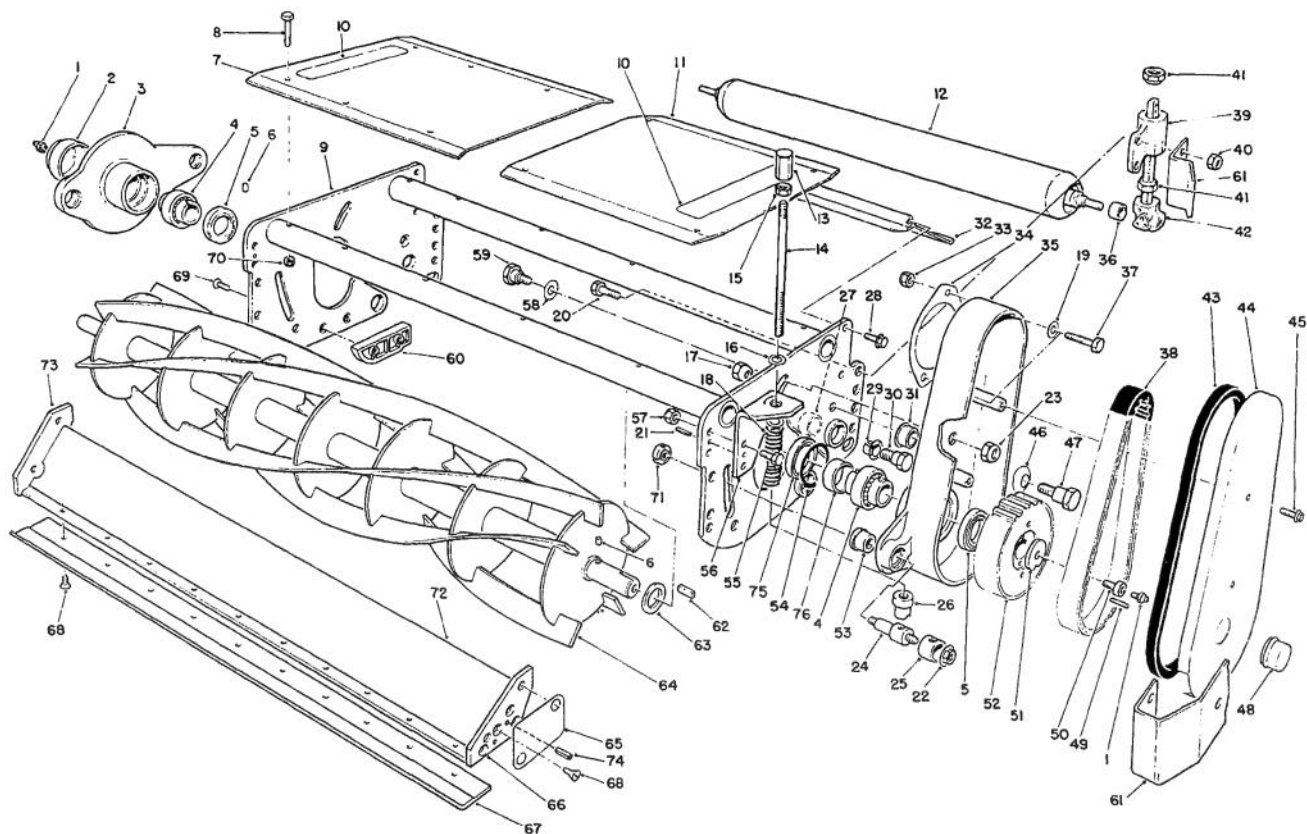

T-0179A

## CUTTING UNIT ASSEMBLY – L.H.

Ref. No.	Part No.	Description	No. Used
1	302-5	Fitting – Grease	2
2	59-5560	Cap – Dust	1
3	59-5550	Housing – Bearing	1
4	59-6140	Bearing	2
5	93-1414	Seal	2
6	48-8880	Pin – Dowel	2
7	59-5830	Cover – Inboard	1
8	3234-34	Screw – Cap Hex. Hd.	10
9	14-0829	Frame (Incl. Ref. #27)	1
10	76-8760	Decal	2
11	59-5840	Cover – Outboard	1
12	59-5630	Assembly – Roller, Rear	1
13	72-0380	Knob – Hex.	2
14	72-0390	Rod – Bedknife Adj.	2
15	3218-5	Nut – Jam	2
16	257-5	Washer	4
17	242-50	Nut – Cone	2
18	92-9231	Spring	2
20	325-7	Screw – Cap Hex. Hd.	4
19	3256-25	Washer – Flat	2
21	32121-2	Pin – Roll	2
22	32128-15	Nut – Flange	2
23	3296-28	Nut – Lock	1
24	72-0440	Pin – Pivot	2
25	72-0420	Clamp – Tube	2

Ref. No.	Part No.	Description	No. Used
26	72-0410	Stand Off	2
27	62-6110	Assembly – Bushing	4
28	3234-12	Screw – Flange Hd.	2
29	256-292	Bushing – Nylon	4
30	84-6090	Bolt – Shoulder	4
31	256-252	Bushing – Flange	2
32	75-7680	Deflector – Grass	1
33	3296-48	Nut – Lock	2
34	48-9050	Plate – Shield, Drive	1
35	92-6099	Housing – Drive, L.H.	1
36	59-5780	Bushing – Roller	2
37	324-6	Screw – Cap Hex. Hd.	2
38	47-7160	Belt	1
39	59-5770	Housing – Roller, Adj.	2
40	3296-25	Nut – Lock	6
41	59-5820	Nut – Cone	4
42	84-6100	Assembly – Collar	2
43	47-7170	Gasket	1
44	75-7590	Cover – Drive Housing L.H.	1
45	3234-14	Screw – Flange Hd.	2
46	3290-440	Washer – Belleville	2
47	48-9020	Bolt	2
48	59-7490	Plug – Grease Fitting	1
49	32121-50	Pin – Roll	1
50	59-6190	Screw – Cap, Reel	1
51	59-6150	Washer – Pulley	1

\*Not Illustrated

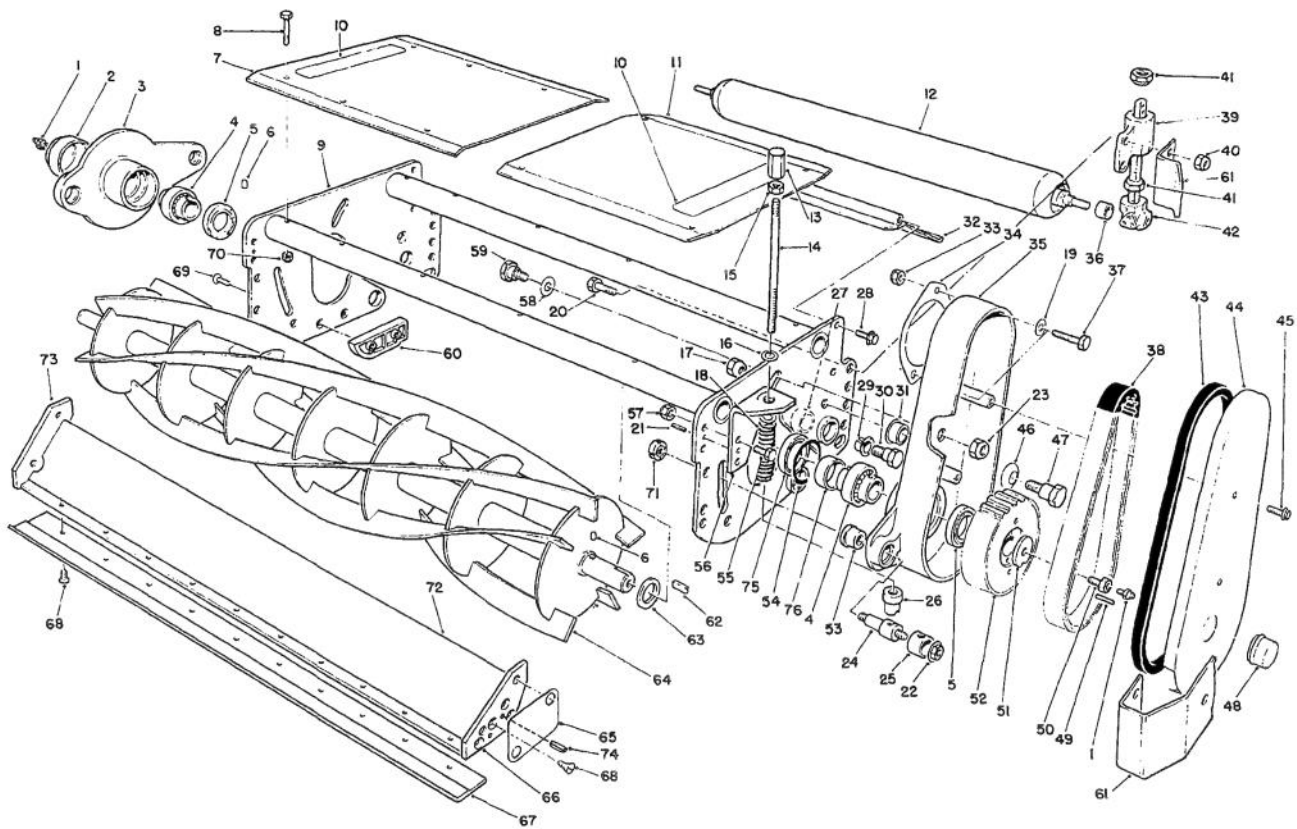

T-0179A

## CUTTING UNIT ASSEMBLY – L.H. (Continued)

Ref. No.	Part No.	Description	No. Used
52	47-7140	Pulley – Driven	1
53	92-9252	Bushing – Flange	2
54	32151-71	Ring – Retaining	1
55	323-7	Bolt	4
56	72-0460	Bracket – L.H. Bedknife Adj.	1
*	72-0450	Bracket – R.H. Bedknife Adj.	1
57	3296-26	Nut – Lock	4
58	3256-69	Washer – Flat	1
59	62-6080	Bolt – Shoulder	1
60	77-4810	Block – Deflector	2
61	72-0470	Guard	1
62	75-7570	Key – Rectangular	1
63	38-7330	Shield – Grass	2
64	14-7419	Reel (5-Blade)	1
*	13-8219	Reel (7-Blade)	1
*	14-0919	Reel (11 Blade)	1
65	76-3580	Spacer	2
66	76-3600	Plate – End, L.H. (11 Blade)	1
67	59-5890	Bedknife (7 Blade)	1

Ref. No.	Part No.	Description	No. Used
67	72-0480	Bedknife (5 Blade)	1
*	76-3620	Bedknife (11 Blade)	1
68	57-4910	Screw (5 & 7 Blade)	10
68	57-4910	Screw (11 Blade)	19
69	32108-101	Screw – Flat Head (7 & 11 Blade)	4
70	3296-42	Nut – Lock	10
71	82-9390	Nut – Special	2
72	59-5470	Bedbar – Welded Assembly (5 & 7 Blade)	1
*72	77-4340	Bedbar (11 Blade)	1
73	76-3610	Plate – End, R.H. (11 Blade)	1
74	32121-11	Pin – Roll	4
75	92-9250	Seal – Grease	1
76	92-9251	Sleeve – Wear	1
*	63-4330	Decal – 5 Blade	1
*	14-2099	Overhaul Kit (Incl. Ref. #4-6, 27, 29, 31, 53, 54, 62, 65 & 68)	1

\*Not Illustrated

Litho in U.S.A.