

FH381V FH430V

4–stroke air cooled v-twin gasoline engine

Service Manual

All rights reserved. No parts of this publication may be reproduced, stored in a retrieval system, or transmitted in any form or by any means, electronic mechanical photocopying, recording or otherwise, without the prior written permission of Quality Assurance Department/Consumer Products & Machinery Company/ Heavy Industries, Ltd., Japan.

No liability can be accepted for any inaccuracies or omissions in this publication, although every possible care has been taken to make it as complete and accurate as possible.

The right is reserved to make changes at any time without prior notice and without incurring an obligation to make such changes to products manufactured previously.

All information contained in this publication is based on the latest product information available at the time of publication. Illustrations and photographs in this publication are intended for reference use only and may not depict actual model component parts.

LIST OF ABBREVIATIONS

A	ampere(s)	lb	pound(s)
ABDC	after bottom dead center	m	meter(s)
AC	alternating current	min	minute(s)
ATDC	after top dead center	N	newton(s)
BBDC	before bottom dead center	Pa	pascal(s)
BDC	bottom dead center	PS	horsepower
BTDC	before top dead center	psi	pound(s) per square inch
°C	degree(s) Celsius	r	revolution
DC	direct current	rpm	revolution(s) per minute
F	farad(s)	TDC	top dead center
°F	degree(s) Fahrenheit	TIR	total indicator reading
ft	foot, feet	V	volt(s)
g	gram(s)	W	watt(s)
h	hour(s)	Ω	ohm(s)
L	liter(s)		

Read OWNER'S MANUAL before operating.

EMISSION CONTROL INFORMATION

1. Crankcase Emission Control System

A sealed-type crankcase emission control system is used to eliminate blow-by gases. The blow-by gases are led to the breather chamber through the crankcase. Then, it is led to the air cleaner.

Oil is separated from the gases while passing through the inside of the breather chamber from the crankcase, and then returned back to the bottom of crankcase.

2. Exhaust Emission Control System

The exhaust emission control system applied to this engine consists of a carburetor and an ignition system having optimum ignition timing characteristics.

The carburetor has been calibrated to provide lean air/fuel mixture characteristics and optimum fuel economy with a suitable air cleaner and exhaust system.

TAMPERING WITH EMISSION CONTROL SYSTEM PROHIBITED

Federal law and California State law prohibits the following acts or the causing thereof: (1) the removal or rendering inoperative by any person other than for purposes of maintenance, repair, or replacement, of any device or element of design incorporated into any new engine for the purpose of emission control prior to its sale or delivery to the ultimate purchaser or while it is in use, or (2) the use of the engine after such device or element of design has been removed or rendered inoperative by any person.

Among those acts presumed to constitute tampering are the acts listed below:

Do not tamper with the original emission related part:

- Carburetor and internal parts
- Spark plugs
- Magneto or electronic ignition system
- Fuel filter element
- Air cleaner elements
- Crankcase
- Cylinder heads
- Breather chamber and internal parts
- Intake pipe and tube

Foreword

This manual is designed primarily for use by trained mechanics in a properly equipped shop. However, it contains enough detail and basic information to make it useful to the owner who desires to perform his own basic maintenance and repair work. A basic knowledge of mechanics, the proper use of tools, and workshop procedures must be understood in order to carry out maintenance and repair satisfactorily. Whenever the owner has insufficient experience or doubts as to his ability to do the work, all adjustments, maintenance, and repair should be carried out only by qualified mechanics.

In order to perform the work efficiently and to avoid costly mistakes, read the text, thoroughly familiarize yourself with the procedures before starting work, and then do the work carefully in a clean area. Whenever special tools or equipment are specified, do not use makeshift tools or equipment. Precision measurements can only be made if the proper instruments are used, and the use of substitute tools may adversely affect safe operation.

To get the longest life out of your engine:

- Follow the Periodic Maintenance Chart in the Service Manual.
- Be alert for problems and non-scheduled maintenance.
- Use proper tools and genuine engine parts.
Genuine parts provided as spare parts are listed in the Parts Catalog.
- Follow the procedures in this manual carefully. Don't take shortcuts.
- Remember to keep complete records of maintenance and repair with dates and any new parts installed.

How to Use This Manual

In this manual, the product is divided into its major systems and these systems make up the manual's chapters. The Quick Reference Guide shows you all of the product's system and assists in locating their chapters. Each chapter in turn has its own comprehensive Table of Contents.

For example, if you want ignition coil information, use the Quick Reference Guide to locate the Electrical System

chapter. Then, use the Table of Contents on the first page of the chapter to find the Ignition coil section.

Whenever you see these WARNING and CAUTION symbols, heed their instructions! Always follow safe operating and maintenance practices.

⚠ WARNING

This warning symbol identifies special instructions or procedures which, if not correctly followed, could result in personal injury, or loss of life.

CAUTION

This caution symbol identifies special instructions or procedures which, if not strictly observed, could result in damage to or destruction of equipment.

This manual contains four more symbols (in addition to WARNING and CAUTION) which will help you distinguish different types of information.

NOTE

- *This note symbol indicates points of particular interest for more efficient and convenient operation.*
- Indicates a procedural step or work to be done.
- Indicates a procedural sub-step or how to do the work of the procedural step it follows. It also precedes the text of a WARNING, CAUTION, or NOTE.
- ★ Indicates a conditional step or what action to take based on the results of the test or inspection in the procedural step or sub-step it follows.

In most chapters an exploded view illustration of the system components follows the Table of Contents. In these illustrations you will find the instructions indicating which parts require specified tightening torque, oil, grease or a locking agent during assembly.

General Information

Table of Contents

Before Servicing.....	1-2
Model Identification	1-4
General Specifications	1-5
Torque and Locking Agent.....	1-6
Special Tools.....	1-8

1-2 GENERAL INFORMATION

Before Servicing

Before starting to service the engine, carefully read the applicable section to eliminate unnecessary work. Photographs, diagrams, notes, cautions, warnings, and detailed descriptions have been included wherever necessary. Nevertheless, even a detailed account has limitations, a certain amount of basic knowledge is required for successful work.

Especially note the following:

- (1) **Dirt**

Before removal and disassembly, clean the engine. Any dirt entering the engine, carburetor, or other parts, will work as an abrasive and shorten the life of engine. For the same reason, before installing a new part, clean off any dust or metal filings.
- (2) **Battery Ground**

Remove the ground (—) lead from the battery before performing any disassembly operations on the equipment. This prevents:
 - (a) the possibility of accidentally turning the engine over while partially disassembled.
 - (b) sparks at electrical connections which will occur when they are disconnected.
 - (c) damage to electrical parts.
- (3) **Tightening Sequence**

Generally, when installing a part with several bolts, nuts, or screws, start them all in their holes and tighten them to a snug fit. Then tighten them evenly, in a staggered sequence. This is to avoid distortion of the part and/or causing gas or oil leakage. Conversely when loosening the bolts, nuts, or screws, first loosen all of them by about a quarter of a turn and then remove them. Where there is a tightening sequence indication in this Service Manual, the bolts, nuts, or screws must be tightened in the order and method indicated.
- (4) **Torque**

When torque values are given in this Service Manual, use them. Either too little or too much torque may lead to serious damage. Use a good quality, reliable torque wrench.
- (5) **Force**

Common sense should dictate how much force is necessary in assembly and disassembly. If a part seems especially difficult to remove or install, stop and examine what may be causing the problem. Whenever tapping is necessary, tap lightly using a wooden or plastic-faced mallet. Use an impact driver for screws (particularly for the removal of screws held by a locking agent) in order to avoid damaging the heads.
- (6) **Edges**

Watch for sharp edges, especially during major engine disassembly and assembly. Protect your hands with gloves or a piece of thick cloth when lifting the engine or turning it over.
- (7) **High-Flash Point Solvent**

A high-flash point solvent is recommended to reduce fire danger. A commercial solvent commonly available in North America is Standard solvent (generic name). Always follow manufacturer and container directions regarding the use of any solvent.
- (8) **Gasket, O-Ring**

Do not reuse a gasket or O-ring once it has been in service. The mating surfaces around the gasket should be free of foreign matter and perfectly smooth to avoid oil or compression leaks.
- (9) **Liquid Gasket, Non-Permanent Locking Agent**

Follow manufacturer's directions for cleaning and preparing surfaces where these compounds will be used. Apply sparingly. Excessive amounts may block engine oil passages and cause serious damage. An example of a non-permanent locking agent commonly available in North America is Loctite Lock'n Seal (Blue).
- (10) **Press**

A part installed using a press or driver, such as a journal, should first be coated with oil on its outer or inner circumference so that it will go into place smoothly.
- (11) **Ball Bearing**

When installing a ball bearing, the bearing race which is affected by friction should be pushed by a suitable driver. This prevents severe stress on the balls and races, and prevents races and balls from being dented. Press a ball bearing until it stops at the stop in the hole or on the shaft.
- (12) **Oil Seal and Grease Seal**

Replace any oil or grease seals that were removed with new ones, as removal generally damages seals.
When pressing in a seal which has manufacturer's marks, press it in with the marks facing out. Seals should be pressed into place using a suitable driver, which contacts evenly with the side of seal, until the face of the seal is even with the end of the hole.
- (13) **Seal Guide**

A seal guide is required for certain oil or grease seals during installation to avoid damage to the seal lips. Before a shaft passes through a seal, apply a little oil, preferably high temperature grease on the lips to reduce rubber to metal friction.
- (14) **Circlip, Retaining Ring**

Replace any circlips and retaining rings that were removed with new ones, as removal weakens and deforms them. When installing circlips and retaining rings, take care to compress or expand them only enough to install them and no more.

Before Servicing

(15) Cotter Pin

Replace any cotter pins that were removed with new ones, as removal deforms and breaks them.



(16) Lubrication

Engine wear is generally at its maximum while the engine is warming up and before all the rubbing surfaces have an adequate lubricative film. During assembly, oil or grease (whichever is more suitable) should be applied to any rubbing surface which has lost its lubricative film. Old grease and dirty oil should be cleaned off. Deteriorated grease has lost its lubricative quality and may contain abrasive foreign particles.

Don't use just any oil or grease. Some oils and greases in particular should be used only in certain applications and may be harmful if used in an application for which they are not intended. This manual makes reference to molybdenum disulfide grease (MoS₂) in the assembly of certain engine parts. Always check manufacturer recommendations before using such special lubricants.

(17) Electrical Wires

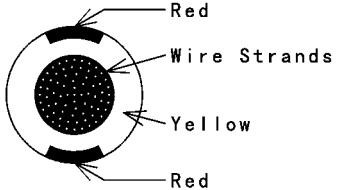
All the electrical wires are either single-color or two-color and, with only a few exceptions, must be connected to wires of the same color. On any of the two-color wires there is a greater amount of one color and a lesser amount of a second color, so a two-color wire is identified by first the primary color and then the secondary color. For example, a yellow wire with thin red stripes is referred to as a "yellow/red" wire; it would be a "red/yellow" wire if the colors were reversed to make red the main color.

Wire (cross-section)	Color Indicated on the Wire	Color Indicated on the Wiring Diagram
	Yellow/Red	

6B020801W1 C

(18) Replacement Parts

When there is a replacement instruction, replace these parts with new ones every time they are removed. There replacement parts will be damaged or lose their original function once removed.

(19) Inspection

When parts have been disassembled, visually inspect these parts for the following conditions or other damage. If there is any doubt as to the condition of them, replace them with new ones.

Abrasion	Crack	Hardening	Warp
Bent	Dent	Scratch	Wear
Color change	Deterioration	Seizure	

(20) Specifications

Specification terms are defined as follows:

"Standards" show dimensions or performances which brand-new parts or systems have.

"Service Limits" indicate the usable limits. If the measurement shows excessive wear or deteriorated performance, replace the damaged parts.

1-4 GENERAL INFORMATION

Model Identification

Electric Starter Model

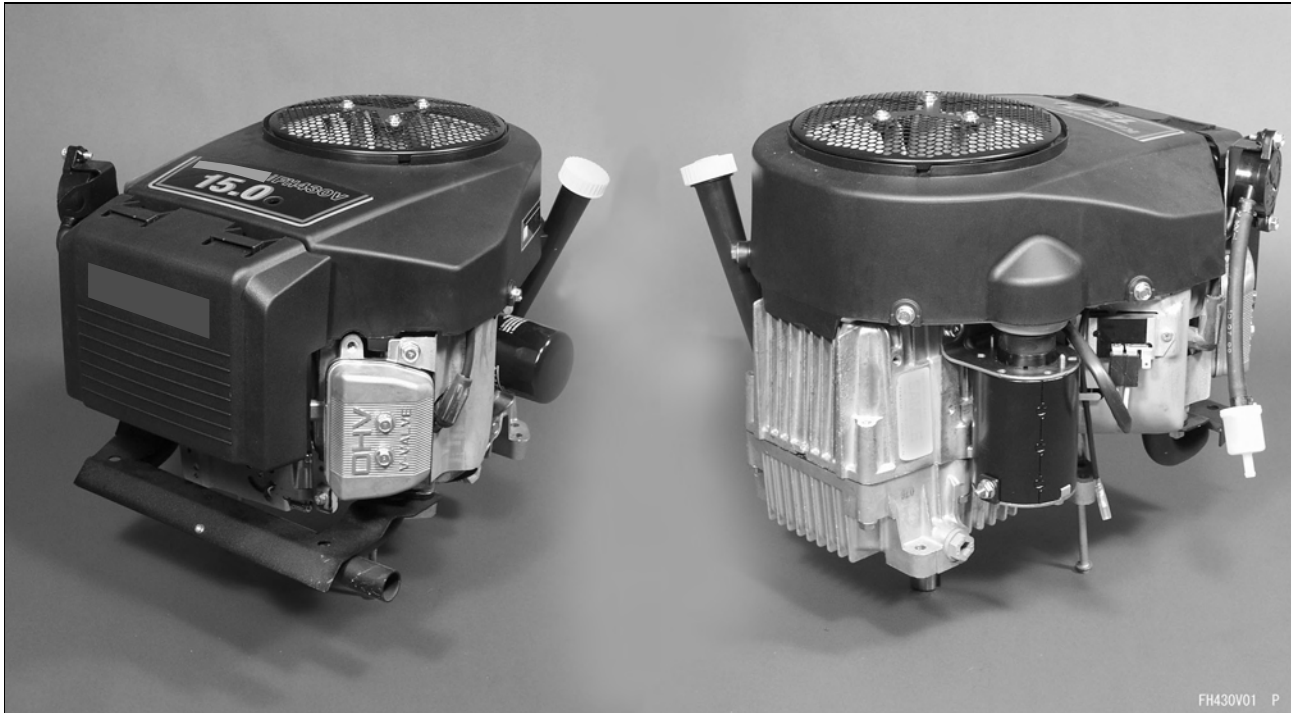

Recoil Starter Model

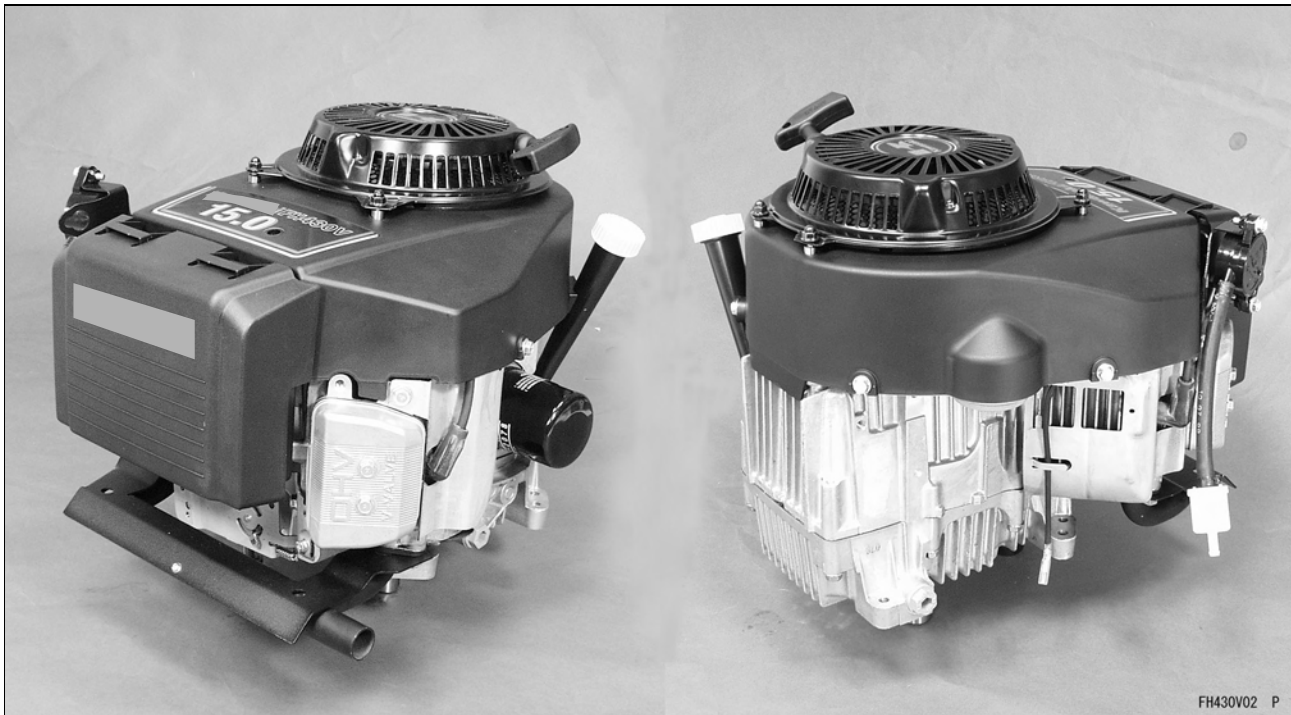

Cylinder Number Designation:

- No.1 Cylinder is the left-hand cylinder viewed from the air cleaner.
- No.2 Cylinder is the right-hand cylinder viewed from the air cleaner.

GENERAL INFORMATION 1-5

General Specifications

Items	FH381V, FH430V
Type of engine	Forced air-cooled, vertical shaft, OHV, 4-stroke gasoline engine.
Cylinder layout	90 V-Twin
Bore x Stroke	65 mm x 65 mm (2.56 in x 2.56 in)
Piston displacement	431 mL (26.3 cu. in)
Direction of rotation	Counterclockwise facing the PTO shaft
Compression release	Automatic compression release
Low idle speed	1550 rpm
Fast idle speed	3600 rpm
Ignition system	Transistorized-fly wheel magneto
RFI	Per Canada and U.S.A. requirements
Starting system	Electric starter and/or recoil starter
Charging system	12 V - 15 amps with regulator
Spark plug	CHAMPION RCJ8Y
Carburetor	Float type, fixed main jet
Fuel pump	Diaphragm type pulse pump
Air cleaner	Dual stage element, dry type
Governor	Flyweight all speed governor
Lubrication system	Pressure feed by positive displacement pump
Oil filter	Cartridge type full flow filter
Oil capacity (when engine is completely dry)	1.8 L (1.9 US-qt)
Cooling system	Forced air cooling by fan
Dimensions (L x W x H) Electric starter model	421 mm x 350 mm x 325 mm (16.6 in x 13.8 in x 12.8 in)
Recoil starter model	421 mm x 350 mm x 353 mm (16.6 in x 13.8 in x 13.9 in)
Dry weight	
Electric starter model	31.8 kg (70.1 lb)
Recoil starter model	29.8 kg (65.7 lb)

Specifications subject to change without notice.

1-6 GENERAL INFORMATION

Torque and Locking Agent

The following tables list the tightening torque for the major fasteners, and the parts requiring use of a non-permanent locking agent or liquid gasket.

Letters used in the "Remarks" column mean:

L : Apply a non-permanent locking agent to the threads.

M : Apply a molybdenum disulfide lubricant (grease or oil) to the threads, seated surface, or washer.

O : Apply an oil to the threads, seated surface, or washer.

S : Tighten the fasteners following the specified sequence.

SS : Apply silicone sealant.

Fastener	Torque			Remarks
	N·m	kgf·m	ft·lb	
Fuel System:				
Throttle Valve Screws	0.7	0.07	6 in·lb	
Main Jet	2.3	0.23	20 in·lb	
Float Chamber Mounting Bolt (Carburetor)	4.5	0.46	40 in·lb	
Governor Arm Clamp Nut	7.8	0.80	69 in·lb	
Governor Shaft Plate Screws	2.0	0.20	18 in·lb	
Holder Plate Nuts (Air Cleaner, Carburetor Mounting)	5.9	0.60	52 in·lb	
Intake Manifold Mounting Bolts	★6.9	★0.70	★61 in·lb	★=S
Cleaner Body Mounting Bolts	5.9	0.60	52 in·lb	
Control Panel Mounting Bolts	5.9	0.60	52 in·lb	
Cooling System:				
Engine-shroud Bolt (M8)	15	1.5	11	
Engine-shroud Bolts (M6)	5.9	0.60	52 in·lb	
Engine-shroud Bolts (Studs)	7.8	0.80	69 in·lb	
Plug Screw (Engine-shroud)	3.4	0.35	30 in·lb	
Flywheel Bolt	56	5.7	41	
Engine Top End				
Cylinder Head Bolts	★25	★2.6	★19	★=S
Valve Clearance Lock Screws	6.9	0.70	61 in·lb	
Connecting Rod Big End Cap Bolts	★5.9	★0.60	★52 in·lb	★=O
Rocker Arm Bolts	28	2.8	20	
Rocker Cover Mounting Bolts	5.9	0.60	52 in·lb	
Exhaust Pipe Flange Nuts	15	1.5	11	
Spark Plugs	22	2.2	16	

GENERAL INFORMATION 1-7

Torque and Locking Agent

Fastener	Torque			Remarks
	N·m	kgf·m	ft·lb	
Lubrication System:				
Engine Drain Plugs	6.9	0.70	61 in·lb	
Oil Passage Plug	3.9	0.40	35 in·lb	
Oil Pump Cover Plate Mounting Bolts	5.9	0.60	52 in·lb	
Oil Filter	in the text	←	←	
Camshaft/Crankshaft:				
Crankcase Cover Bolts	★25	★2.6	★19.0	★= S
Breather Chamber Cover Bolts	5.9	0.60	52 in·lb	
Electrical System:				
Starter Coil Screws	3.4	0.35	30 in·lb	
Flywheel Bolt	56	5.7	41	
Fan Housing Bolts	5.9	0.60	52 in·lb	
Screen Screws	5.9	0.60	52 in·lb	
Regulator Screws	3.4	0.35	30 in·lb	
Ignition Coil Bolts (Studs)	7.8	0.80	69 in·lb	
Ignition Coil Bolts (Bolts)	5.9	0.60	52 in·lb	
Starter Motor Mounting Bolts	15	1.5	11	
Starter Motor Through Bolts	3.9	0.40	35 in·lb	
Recoil Starter Mounting Nuts	5.9	0.60	52 in·lb	
Recoil Starter Retainer Screw	7.8	0.80	69 in·lb	
Spark Plugs	22	2.2	16	

The table below, relating tightening torque to thread diameter, lists the basic torque for the bolts and nuts. Use this table for only the bolts and nuts which do not require a specific torque value. All of the values are for use with dry solvent-cleaned threads.

Basic Torque for General Fasteners

Threads dia (mm)	Torque		
	N·m	kgf·m	ft·lb
4	2.0	0.20	17 in·lb
5	3.4	0.35	30 in·lb
6	5.9	0.60	52 in·lb
8	15	1.5	11

1-8 GENERAL INFORMATION

Special Tools

Piston Ring Pliers: 57001-115

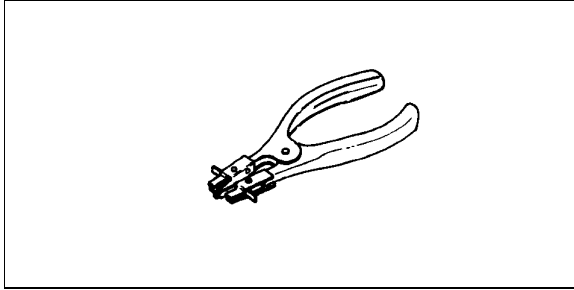

Piston Ring Compression Belt, Ø55 – Ø67: 57001-1096

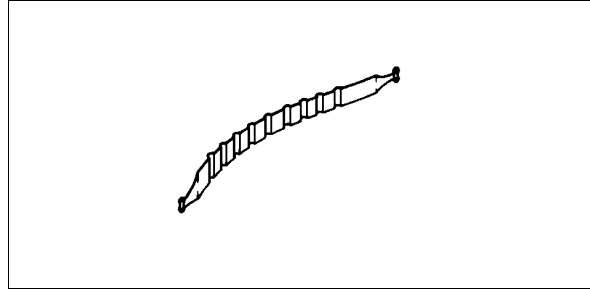

Oil Pressure Gauge, 5kgf/cm²: 57001-125

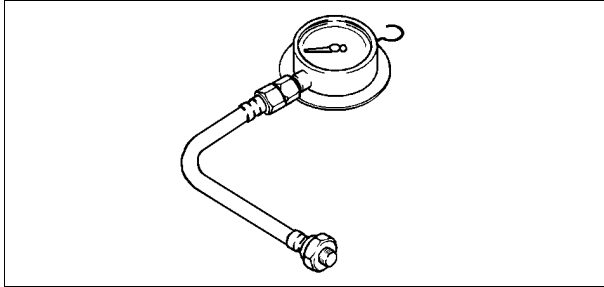

Valve Seat Cutter, 45° - Ø27.5: 57001-1114

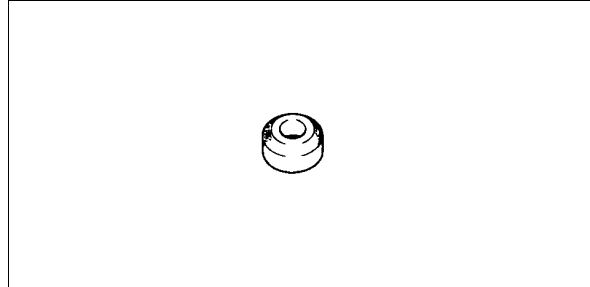

Compression Gauge: 57001-221

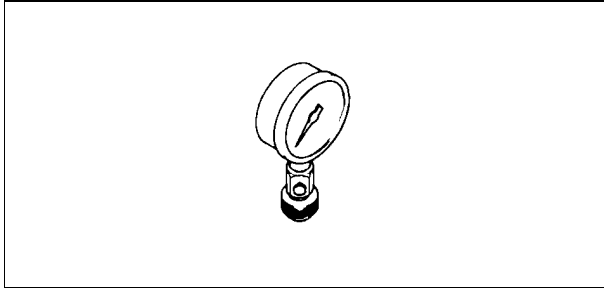

Valve Seat Cutter, 32° - Ø25.0: 57001-1118

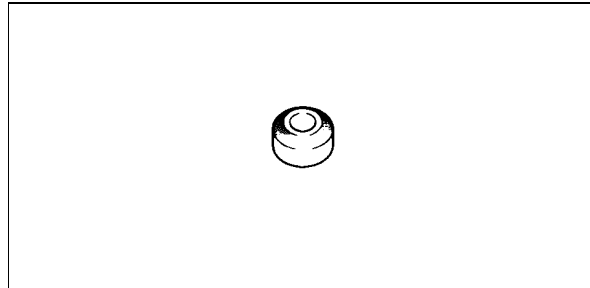

Oil Pressure Gauge Adapter, PT 1/8: 57001-1033

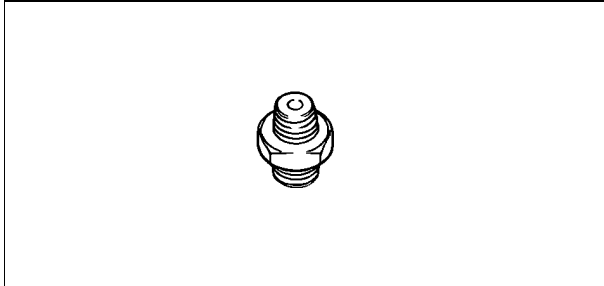

Valve Seat Cutter, 32° - Ø28.0: 57001-1119

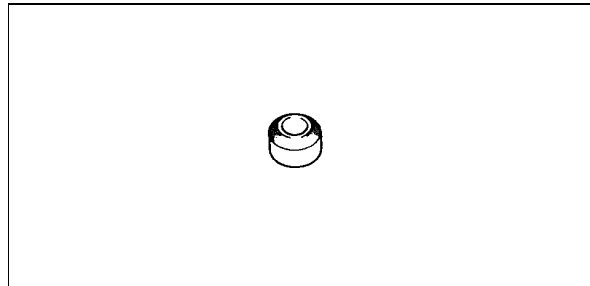

Piston Ring Compression Grip: 57001-1095

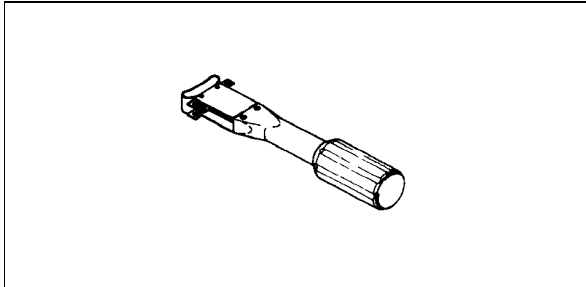

Valve Seat Cutter Holder Bar: 57001-1128

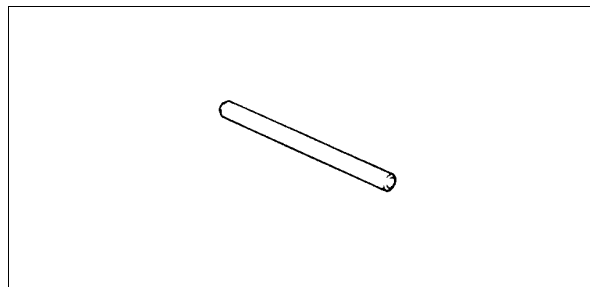

Special Tools

Compression Gauge Adapter M14 x 1.25: 57001-1159

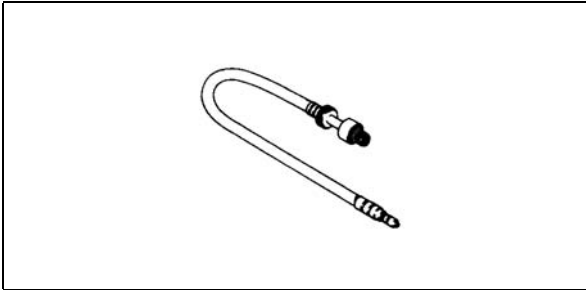

Bond (Silicone Sealant) : 56019-120

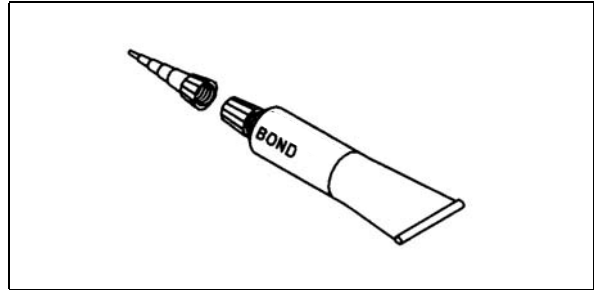

Oil Filter Wrench: 57001-1249

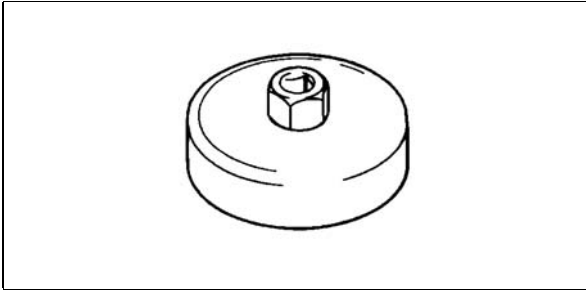

Valve Seat Cutter Holder Ø6: 57001-1360

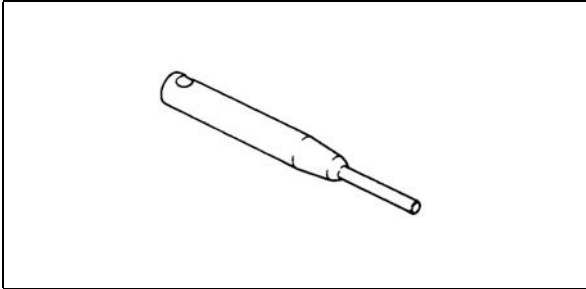

Hand Tester: 57001-1394

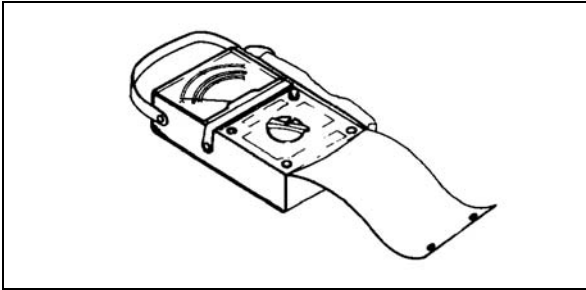

Periodic Maintenance

Table of Contents

Periodic Maintenance Chart.....	2-2
Specifications.....	2-3
Periodic Maintenance Procedures.....	2-4
Fuel System.....	2-4
Low Idle Speed Adjustment.....	2-4
High Idle Speed Adjustment.....	2-4
Fuel system Cleanliness Inspection.....	2-5
Fuel Pump Inspection.....	2-5
Fuel Filter Inspection.....	2-5
Air Element Removal.....	2-6
Air Element Installation.....	2-6
Air Element Cleaning and Inspection.....	2-6
Air Cleaner Housing (Case and Body) Inspection.....	2-7
Engine Top End.....	2-7
Cylinder Head Cleaning and Inspection.....	2-7
Valve Clearance Inspection.....	2-8
Valve Clearance Adjustment.....	2-8
Valve Seat Inspection.....	2-9
Valve Seat Repair.....	2-9
Lubrication System.....	2-11
Oil Level Inspection.....	2-11
Oil Change.....	2-12
Oil Filter Change.....	2-12
Oil Filter Installation.....	2-12
Electrical System.....	2-13
Spark Plug Cleaning and Inspection.....	2-13
Spark Plug Gap Inspection.....	2-13

2-2 PERIODIC MAINTENANCE

Periodic Maintenance Chart

To ensure satisfactory operation over an extended period of time, any engine requires normal maintenance regular intervals. The Periodic Maintenance Chart below shows periodic inspection and maintenance items and suitable intervals. The bullet mark (●) designates that the corresponding item should be performed at that interval.

Some adjustments require the use of special tools or other equipment. An electronic tachometer will facilitate setting idle and running speeds.

OPERATION	INTERVAL							Refer-ence
	Daily	First 8 hr.	Every 25 hr.	Every 50 hr.	Every 100 hr.	Every 200 hr.	Every 300 hr.	
Check or clean air intake screen	●							
Check and add engine oil	●							P11
Check for fuel and oil leakage	●							
Check for loose or lost nuts and screws	●							
Check battery electrolyte level	●							
Clean air cleaner foam element (1)			●					P6~P7
Clean air cleaner paper element (1)				●				P6~P7
Clean dust and dirt from cylinder and cylinder head fins (1)					●			
Tighten nuts and screws					●			
Change engine oil		●			●			P12
Clean and re-gap spark plugs					●			P13
Change Oil filter						●		P12
Change air cleaner paper element (1)						●		P6~P7
★ Check and adjust valve clearance							●	P8
★ Clean and lap valve seating surface							●	P9~P11
★ Clean combustion chamber							●	P7

(1): Service more frequently under dusty conditions.

★: These items must be performed with the proper tools. See your authorized Engine Dealer for service, unless you have the proper equipment and mechanical proficiency.

Specifications

Item	Standard
Fuel System	
Idle speed: (1)	
Low idle speed	1550 r/min (rpm)
High idle speed	3600 r/min (rpm)
Air cleaner:	
Type	Dual stage filtration system
Pre-cleaner	Foam element
Second-stage cleaner	Paper element
Engine Top End	
Valve clearance	Intake, Exhaust 0.10 ~ 0.15 mm (0.004 ~ 0.006 in.)
Valve seating surface angle	Intake, Exhaust 45°
Valve seating surface width	Intake, Exhaust 0.6 ~ 0.9 mm (0.024 ~ 0.035 in.)
Lubrication System	
Engine oil	
Type	SF, SG, SH or SJ class
Viscosity	SAE40, SAE30, SAE10W-30/10W-40 or SAE5W-20
Capacity	[When filter is not removed] 1.5 L (1.6 US qt) [When filter is removed] 1.7 L (1.8 US qt) [When engine is completely dry] 1.8 L (1.9 US qt)
Level	Operating range (grid area) on dipstick
Electrical System	
Spark plug gap	0.75 mm (0.030 in.)

(1) Idle speeds may vary depending on each equipment. Refer to the equipment specification.

- Special Tools - Valve Seat Cutter, 45° - φ27.5 : 57001-1114**
Valve Seat Cutter, 32° - φ25.0 : 57001-1118
Valve Seat Cutter, 32° - φ28.0 : 57001-1119
Valve Seat Cutter Holder Bar : 57001-1128
Valve Seat Cutter Holder - φ6.0 : 57001-1360
Oil Filter Wrench : 57001-1249

2-4 PERIODIC MAINTENANCE

Periodic Maintenance Procedures

Fuel System

Low Idle Speed Adjustment

- Disconnect all possible external loads from the engine.
- Start the engine and warm it up thoroughly.

WARNING

Always keep your hands clear of the moving parts.

- Move the throttle lever on dash to the idle position, and hold the throttle lever on the carburetor in closed position (turn the governor arm clockwise all the way) and adjust the low idle speed screw [A] until the engine idles at specified speed.

Idle Speed (Carburetor idle rpm)
1450 rpm

- Release the throttle lever and adjust the low idle speed set screw [B] on the control plate to obtain the specified governed low idle speed.

Low Idle Speed (Governed idle rpm)
1550 rpm

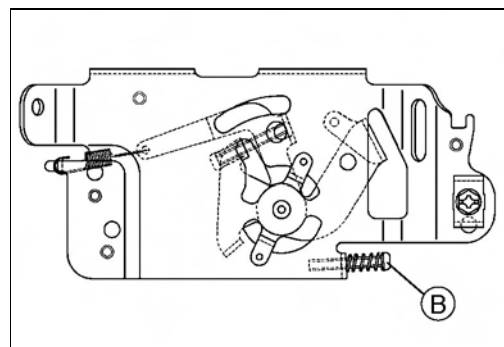

High Idle Speed Adjustment

NOTE

- High idle speed adjustment should be made after the idle speed adjustment is performed.

CAUTION

Do not adjust high idle speed with the air cleaner removed.

- Start and warm up the engine thoroughly.

WARNING

Always keep your hands clear of the moving parts.

- Move the throttle lever at a dash to the high idle position and match the lever hole position with the panel hole by inserting 6 mm dia., pin or bolt [A].
- Loosen two M6 control panel mounting bolts [B] enough to move the control panel assembly.
- Carefully move the control panel assembly right side [C] up or down to obtain the specified high idle speed.

High Idle Speed
3600 rpm

- Tighten the M6 Mounting bolts.
Torque - Control Panel Mounting Bolts: 5.9 N·m (0.60 kgf·m, 52 in·lb)
- Remove the 6 mm dia., pin or bolt.
- Check the idle speed, and readjust the idle speed if necessary.

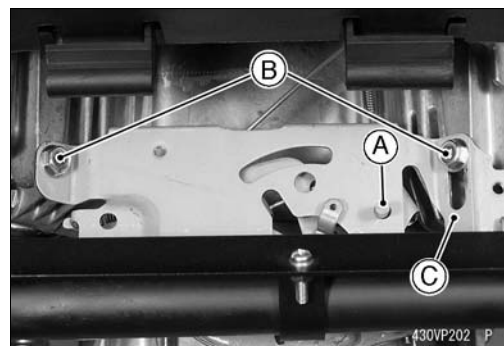

CAUTION

Be sure to make the idle and high idle speeds respectively correspond to those of the equipment.

Periodic Maintenance Procedures

Fuel system Cleanliness Inspection

⚠ WARNING
Gasoline is extremely flammable and can be explosive under certain conditions. Turn the ignition switch OFF. Do not smoke. Make sure the area is well-ventilated and free from any source of flame or sparks; this includes any appliance with a pilot light.

- Remove the air cleaner (see Fuel System chapter).
- Place a suitable container [A] under the float chamber mounting bolt [B] on the carburetor.
- Remove the float chamber to drain the carburetor and check to see if water or dirt has accumulated in the carburetor.
- Tighten the float chamber mounting bolt.

Torque - Float Chamber Mounting Bolt: 4.5 N·m (0.46 kgf·m, 40 in·lb)

- If any water or dirt is found, clean the carburetor (see Fuel System chapter), and fuel tank, and check the fuel filter.

Fuel Pump Inspection

- Check the vent hole [A] and filter [B] for plugging or clogging.
- ★ If vent hole and filter are plugged or clogged, remove the foreign matter from them.

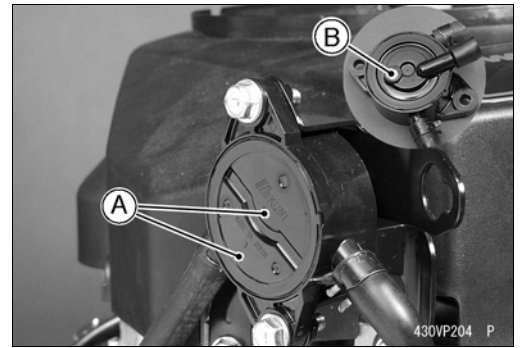
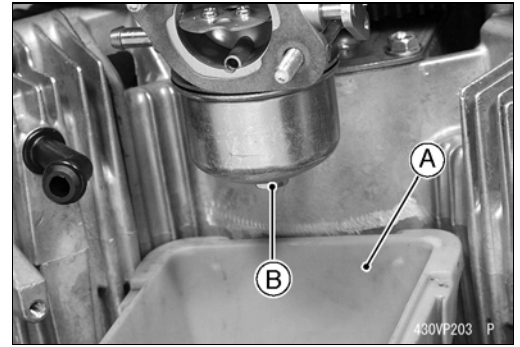

Fuel Flow Test:

⚠ WARNING
Gasoline is extremely flammable and can be explosive under certain conditions. Turn the ignition switch OFF. Do not smoke. Make sure the area is well-ventilated and free from any source of flame or sparks; this includes any appliance with a pilot light.

- Disconnect the fuel pump outlet nozzle from the tube.
- Connect a suitable hose [A] to the outlet nozzle.
- Run the lower end of the hose into a container.
- Start the engine, Check the fuel flow.
- ★ If fuel flow is none or little, replace the fuel pump.
- ★ Check for clogged or damaged tubes and fuel filter. Replace the faulty parts.

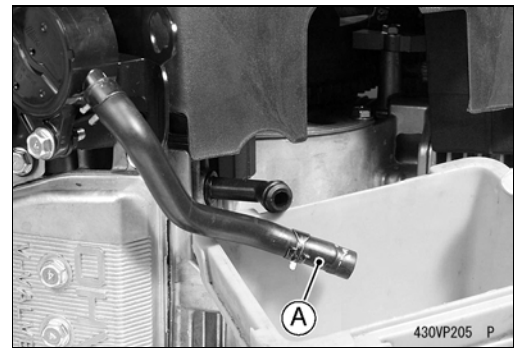

Fuel Filter Inspection

- Visually inspect the fuel filter [A].
- ★ If the filter is clear with no signs of dirt or other contamination, it is OK and need not be replaced.
- ★ If the filter is dark or looks dirty, replace with a new one. Also check the rest of the fuel system for contamination.

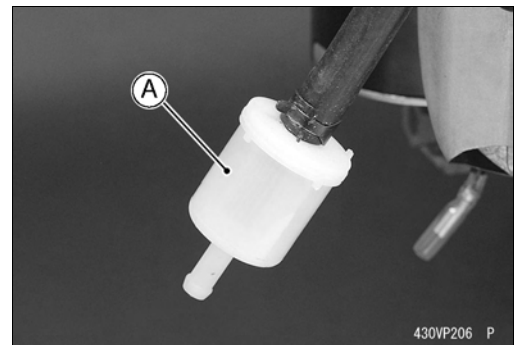

2-6 PERIODIC MAINTENANCE

Periodic Maintenance Procedures

Air Element Removal

- Push down the latches [A] and remove the air cleaner case [B].

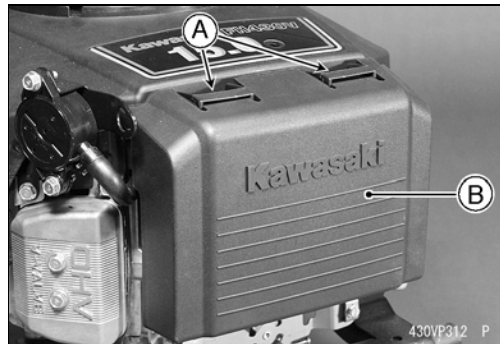

- Remove:
 - Paper Element [A]
 - Foam Element [B]

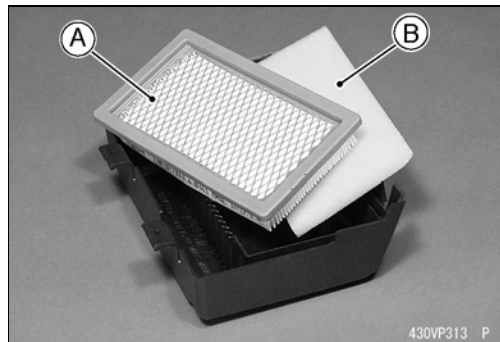

Air Element Installation

- Install the element correctly on the air cleaner case.
- Be sure the foam element is in-place in the air cleaner case.
- Be sure the paper element is in-place in the air cleaner case.
- Install the air cleaner case on the air cleaner body.
- Be sure the latches of air cleaner case are in place in the air cleaner body.
- Be sure that the hollows [A] of the air cleaner case and projection [B] of the air cleaner body are fitting.

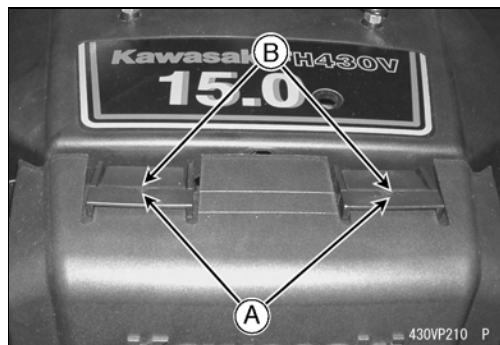

Air Element Cleaning and Inspection

NOTE

- In dusty areas, the elements should be cleaned more frequently than the recommended intervals.

⚠ WARNING

Because of the danger of highly flammable liquids, do not use gasoline or a low flash-point solvent to clean the element.

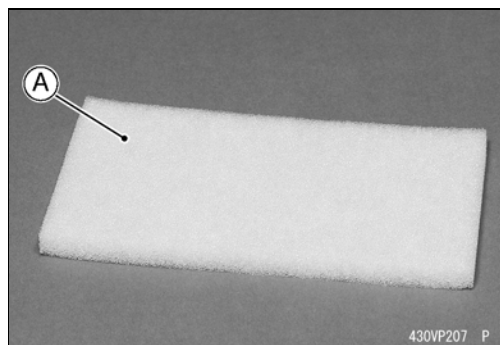

Periodic Maintenance Procedures

- Remove the foam element and the paper element.
- Clean the foam element [A] in a bath of detergent and water, and let the element air-dry thoroughly before installing it.
- Clean the paper element [A] by tapping it gently on a flat surface to remove dust. If the element is very dirty, replace it with a new one.

CAUTION
Do not use compressed air to clean the paper element. Do not oil the paper or foam element.

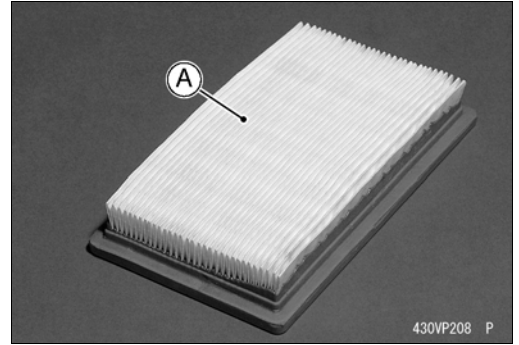

Air Cleaner Housing (Case and Body) Inspection

- Clean the housing with detergent and water and dry thoroughly.
- Check the housing for deformation or other damage. The housing must seal well and permit only filtered air to reach the carburetor.
- ★ If the housing is damaged, it must be replaced.
- Check that no foreign material is obstructing the air passage.

Engine Top End

Cylinder Head Cleaning and Inspection

- Scrape the carbon deposits from the head and exhaust port with a suitable tool [A].
- To avoid gouging, use scrapers that are made of a material that will not cause damage.
- Clean the head in a bath of high flash-point solvent and dry it with compressed air.

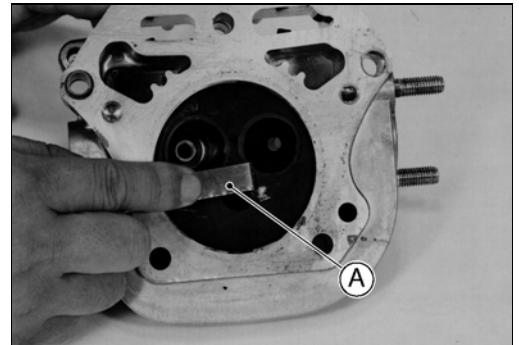

⚠ WARNING
Clean the cylinder head in a well-ventilated area, and take care that there are no sparks or flame anywhere near the working area; this includes any appliance with a pilot light. Do not use gasoline or a low flash-point solvent to clean the cylinder head. A fire or explosion could result.

- Straight edge [A] across the mating surface of the head at several different points, and measure warp by inserting a thickness gauge [B] between the straightedge and head.
- ★ If warp exceeds the service limit, repair the mating surface. Replace the cylinder head if the mating surface is badly damaged.

Cylinder Head Warp

Service Limit: 0.03 mm (0.001 in.)

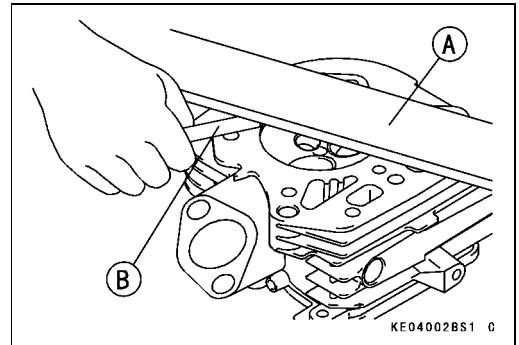

- Check the cylinder head for cracks or other damage.
- Cracks not visible to the eye may be detected by using a metal crack detection system. (Visual color check: commonly found at automotive parts tore.)
- If a crack is present in the cylinder head, replace it.
- Inspect the mating surface for burrs and nicks.

2-8 PERIODIC MAINTENANCE

Periodic Maintenance Procedures

Valve Clearance Inspection

NOTE

- Valve clearance must be checked when the engine is cold (at room temperature).
- Remove the rocker cover (see Engine Top End chapter).
- Place the piston at top dead center (TDC) of the compression stroke turning the crankshaft clockwise facing the flywheel.

No.1 Cylinder:

- The left projection [A] on the flywheel is faced with the right leg [B] on the #1 ignition coil [C] as shown.
- Check the intake and exhaust valves are closed completely, if not, turn the flywheel one turn (360°) clockwise and face the left projection with the right leg again.

No.2 Cylinder:

- The left projection [A] on the flywheel is faced with the right leg [B] on the #2 ignition coil [C] as shown. Follow No.1 Cylinder alignment.

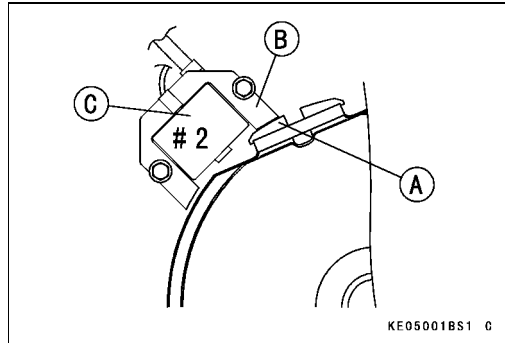
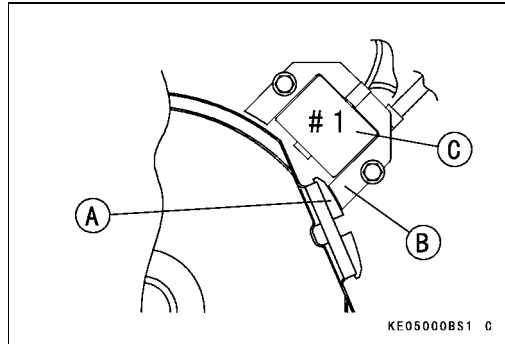

- Then check the valve clearance.
- Using a thickness gauge [A], measure the valve clearance between the rocker arm [B] and the valve stem end.
- ★ If the valve clearance is incorrect, adjust it.

Valve Clearance (when cold)

Intake, Exhaust 0.10 ~ 0.15 mm (0.004 ~ 0.006in.)

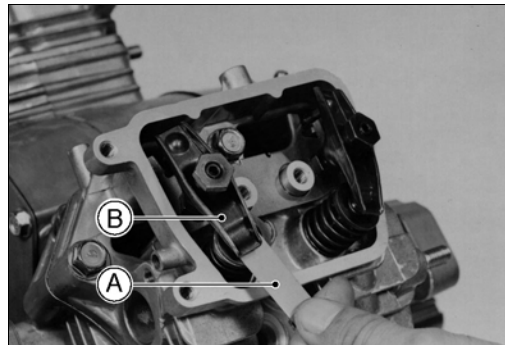

Valve Clearance Adjustment

- Since valve repairs change the valve clearance, adjust the valve clearance to the specification.
- Assemble the cylinder head and install the cylinder head assembly on the block (see Engine Top End chapter).
- Turn the crankshaft to the proper direction until the piston is at TDC of the compression stroke (described above).
- Loosen the lock screws [A] and valve clearance adjusting nuts [B].
- Insert a 0.10 mm (0.004 in.) thickness gauge [C] between the rocker arm and valve stem, and tighten the adjusting nut until the thickness gauge begins to bind between the rocker arm and valve stem end. Use a sweeping motion with the thickness gauge while making this adjustment.

Valve Clearance (when cold)

Intake, Exhaust 0.10 ~ 0.15 mm (0.004 ~ 0.006in.)

- Holding the adjusting nut with a wrench, tighten the lock screw to the specified torque.

Torque - Valve Clearance Lock Screws: 6.9 N·m (0.70 kgf·m, 61 in·lb)

- Do not overtighten.
- Remeasure any clearance that was adjusted. Readjust if necessary.

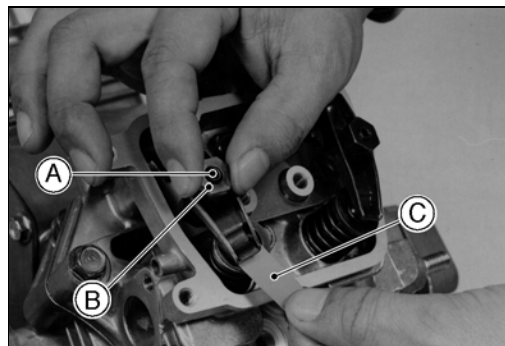

Periodic Maintenance Procedures

Valve Seat Inspection

- Remove the valve (see Engine Top End chapter).
- Inspect the valve seats for damage.
- ★ If the seats are warped or distorted beyond reconditioning, replace the cylinder head.
- Pitted or worn valve seats can be refaced. Lap the valves to the seats after refacing.
- Coat the valve seat with machinist's dye.
- Push the valve into the guide.
- Rotate the valve against the seat with a lapping tool.
- Pull the valve out, and check the seating pattern on the valve head. It must be the correct width [A] and even all the way around.

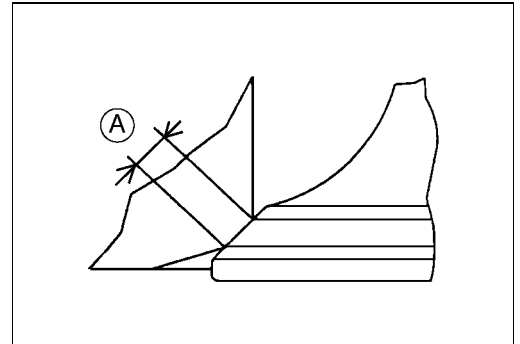

NOTE

- *The valve stem and guide must be in good condition or this check will not be valid.*
- ★ If the valve seating pattern is not correct, repair the seat.

Valve Seating Surface Width (STD)

Inlet, Exhaust 0.6 ~ 0.9 mm (0.024 ~ 0.035 in.)

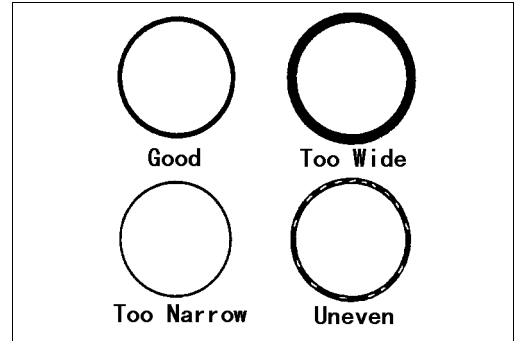

Valve Seat Repair

- Follow the manufacturer's instructions for use of valve seat cutters.

Special Tools

Intake Valve:

Seat Cutter 45° - ϕ 27.5 57001-1114
Outside Cutter 32° - ϕ 28.0 57001-1119

Exhaust Valve:

Seat Cutter 45° - ϕ 27.5 57001-1114
Outside Cutter 32° - ϕ 25.0 57001-1118

Valve Seat Cutter Holder- ϕ 6.0: 57001-1360

Valve Seat Cutter Holder Bar: 57001-1128

- ★ If the manufacturer's instructions are not available, use the following procedure.

Seat Cutter Operating Cares:

1. This valve seat cutter is designed only for valve seat repair. Therefore the cutter must not be used for other purposes.
2. Do not drop or hit the valve seat cutter, or the diamond particles may fall off.
3. Do not fail to apply engine oil to the valve seat cutter before grinding the seat surface. Also wash off ground particles sticking to the cutter with washing oil.

NOTE

- *Do not use a wire brush to remove the metal particles from the cutter. It will take off the diamond particles.*

4. Setting the valve seat cutter holder [A] in position, operate the cutter [B] with one hand [C]. Do not apply too much force to the diamond portion.

NOTE

- *Prior to grinding, apply oil to the cutter, and during the operation wash off any ground particles sticking to the cutter with washing oil.*

5. After use wash the cutter with washing oil and apply a thin layer of engine oil before storing.

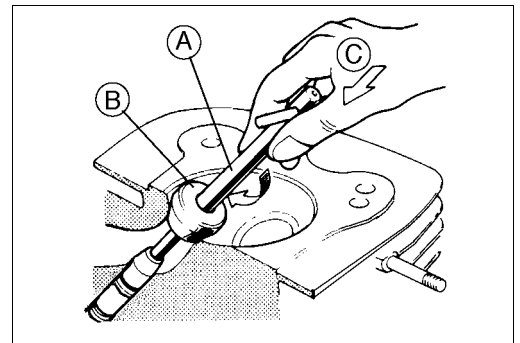

2-10 PERIODIC MAINTENANCE

Periodic Maintenance Procedures

Marks Stamped on the Cutter:

The marks stamped on the back of the cutter represent the following.

1	Cutter number, selected from 1 to 12
30°	Cutter angle [A]
37.5	Cutter diameter of cutter [B]
KS8B	Manufactured lot number

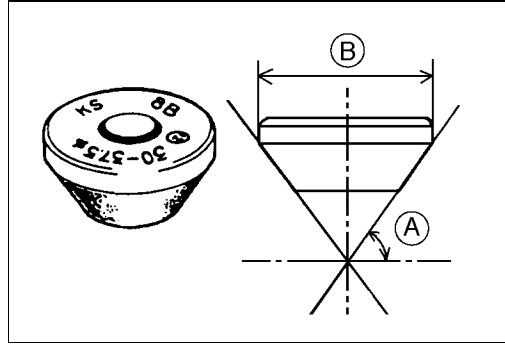

Operating Procedures:

- Clean the seat area carefully.
- Recondition the valve seats with the valve seat cutters (45°, 32°) and lap the valves.
- Check the seats for good contact all the way around with machinist's dye.
- Measure the seat width [A]. If it is more than the STD width, the seating surface should be refaced.
- If the valve seating pattern is not correct, repair the seat.

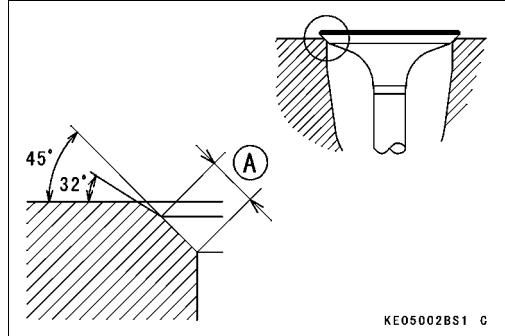

- Coat the seat with machinist's dye.
- Fit a 45° cutter [A] to the holder and slide it into the valve guide.
- Resurface the valve seat with a 45° cutter, removing only enough material to produce a smooth and concentric seat.

CAUTION

Do not grind the seat too much. Overgrinding will reduce valve clearance by sinking the valve into the head. If the valve sinks too far into the head, it will be impossible to adjust the clearance, and the cylinder head must be replaced. Do not turn the cutter counterclockwise or drop it against the seat, or it will be dulled.

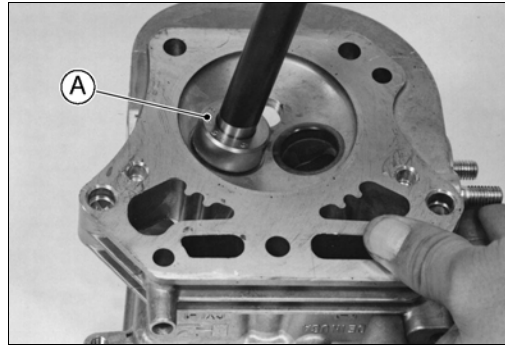

- Use a 32° seat cutter [A] to narrow the seat width to the STD width.
- Turn the seat cutter one turn at a time while pressing down very lightly. Check the seat width after each turn.

CAUTION

The 32° cutter removes material very quickly. Check the seat width frequently to prevent over grinding.

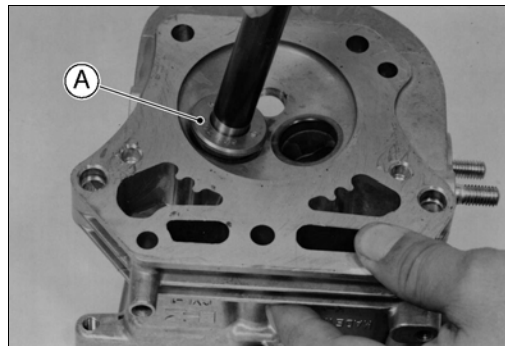

NOTE

- *Keep the seat width as close as possible to the STD width.*
- Make a light pass with the 45° cutter to remove any possible burrs at the edge of the seat.
- After resurfacing the seat, inspect for even valve seating.
- Apply a machinist's dye to the valve face, insert the valve, and snap it closed against the seat several times. The valve surface should show good contact all the way around. Be sure the valve seat is centered on the valve face. The position of the valve in the seat is evident after lapping the valve.
- ★ If the seat does not make proper contact, lap the valve into seat with a vacuum cap tool.

Periodic Maintenance Procedures

- Coat the face of valve sparingly with a fine lapping compound.
- Use the vacuum cup tool [A], to grip top of the valve [B]. Rotate the valve in a circular motion to lap the valve to the seat.
- Lift the valve slightly from the seat every 8 to 10 strokes, continue lapping operation until a uniform ring appears around entire surface of the valve face.

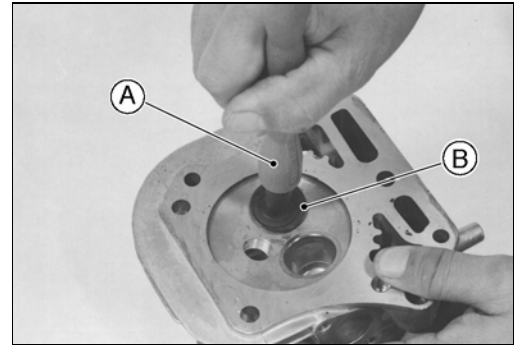

- When lapping is completed, wash all parts in solvent to remove lapping compound. Dry the parts thoroughly.
- Note the position of the lapping mark on the valve face. The lapping mark should appear on or near the center of the valve face.
- When the engine is assembled, be sure to adjust the valve clearances (see Valve Clearance Adjustment).

Lubrication System

Oil Level Inspection

- Place the engine on a level surface.
- Remove the oil filler cap [A] and wipe its dipstick [B] with a clean cloth.
- Insert the dipstick into tube [C] without screwing it in, then check the oil level.
- The oil level should be the operating range [D] (grid area) on the dipstick.
- ★ If the oil level is "ADD" range [E], add enough engine oil to bring oil level to the operating range.

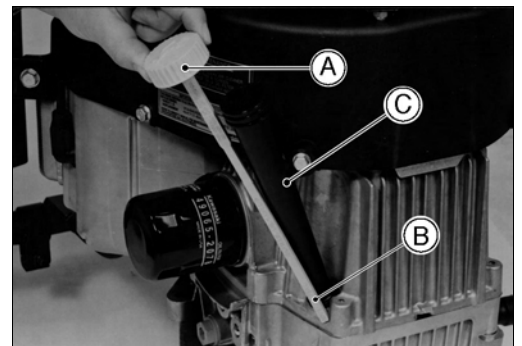

CAUTION
Do not add more oil above the operating range. Excess oil will cause a smoking condition.

- Use the same type and make of oil that is already in the engine.

NOTE

- *If the engine oil type and make are unknown, use any brand of the specified oil to top up the level in preference to running the engine with the oil level low. Then at your earliest convenience, change the oil completely.*
- ★ If the oil level is "FULL" range [F], drain the excess oil by loosening the drain plug.

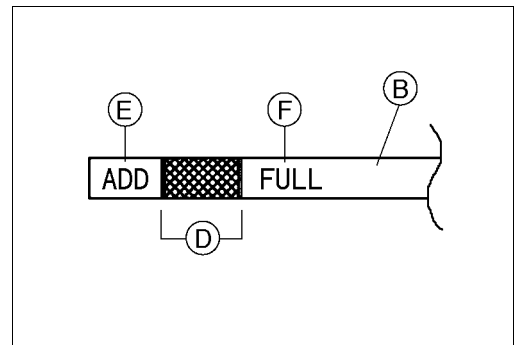

2-12 PERIODIC MAINTENANCE

Periodic Maintenance Procedures

Oil Change

- Change the oil after first 8 hours of operation. Thereafter change oil every 100 hours.
- Start and warm up the engine so the oil will drain easily. Stop the engine.
- Place the engine on a level surface.
- Place a suitable container under the engine.
- Remove the drain plug [A] and drain the oil.

⚠ WARNING

Be careful of hot oil when drained. It may be hot enough to burn you severely.

- Check the O-ring [B] at the drain plug for damage. Replace the O-ring with a new one if it is damaged.
- Install the drain plug with the O-ring and tighten it.

Torque - Oil Drain Plug : 6.9 N·m (0.70 kgf·m, 61 in·lb)

- Remove the oil filler cap and pour in the specified type and amount of oil.

Engine Oil :

Type: SF, SG, SH or SJ Class
Viscosity: SAE40, SAE30, SAE10W-30/SAE10W-40, or SAE5W-20
Capacity: [When filter is not removed] 1.5 L (1.6 US qt)
[When filter is removed] 1.7 L (1.8 US qt)

NOTE

- Some increase in oil consumption may be expected when a multi grade engine oil (10W-30/10W-40, 5W-20) is used. Check the oil level frequently.

Oil Filter Change

- Using a strap wrench or oil filter wrench [A], remove the oil filter [B].
- Special Tool - Oil Filter Wrench : 57001-1249**
- When unscrewing the oil filter, place a suitable container beneath the oil drip tray to receive oil from the oil filter and oil passages in the engine. Turn the filter counterclockwise to remove it.

Oil Filter Installation

- Apply light film of engine oil to the seal [A].
- Install new filter.
- Turn the filter until the seal contacts mounting surface [B] of the engine. Then turn the filter BY HAND (S) 3/4 turn more.
- Run the engine at slow idle speed 2 minutes. Check for leaks around the engine.
- Stop the engine. Check the oil level (see Oil Level Inspection).

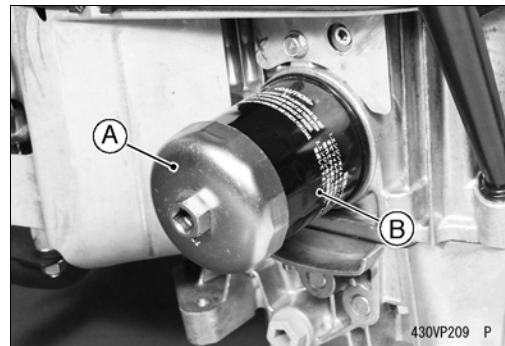
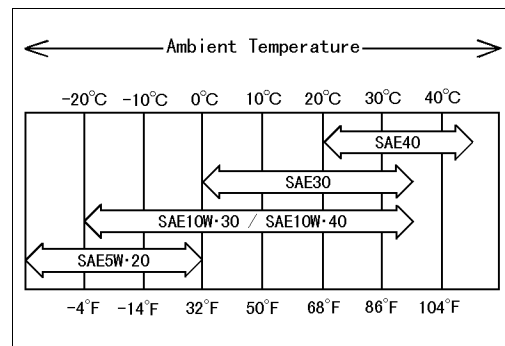
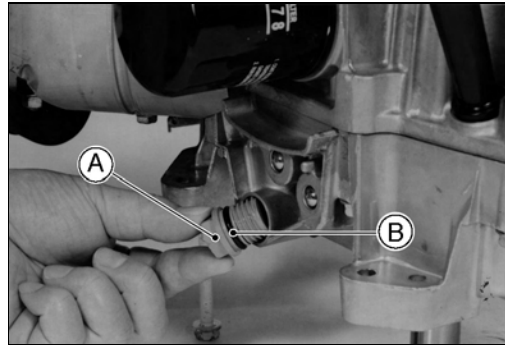

Periodic Maintenance Procedures

Electrical System

Spark Plug Cleaning and Inspection

- Remove the spark plug (See Electrical System chapter).
- ★ If the plug is oily or has carbon build up on it, clean the plug using a high flash-point solvent and a wire brush or other suitable tool.
- ★ If the spark plug electrodes are corroded or damaged, or if the insulator is cracked, replace the plug. Use the standard spark plug or its equivalent.
 - [A] Insulator
 - [B] Center Electrode
 - [C] Plug Gap
 - [D] Side Electrode

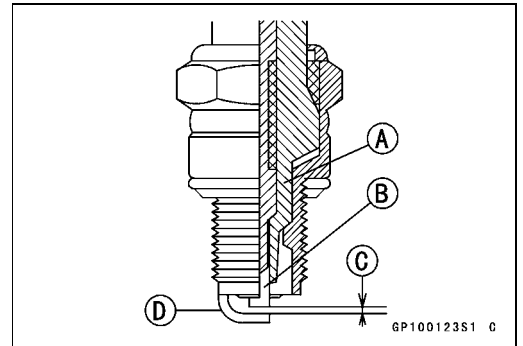

Spark Plug Gap Inspection

- Measure the gap with a wire-type thickness gauge.
- ★ If the gap is incorrect, carefully bend the side electrode with a suitable tool to obtain the correct gap.

Spark Plug Gap

Standard: 0.75 mm (0.030 in.)

Fuel System

Table of Contents

Exploded View.....	3-2
Specifications.....	3-4
Governor Link Mechanism.....	3-5
Control Panel Assembly Removal.....	3-5
Control Panel Assembly Installation.....	3-5
Governor Arm Removal.....	3-5
Governor Arm Installation.....	3-6
Governor Assembly Removal.....	3-6
Governor Assembly Installation.....	3-6
Governor Assembly Inspection.....	3-7
Governor Shaft Removal.....	3-7
Governor Shaft Installation.....	3-7
Carburetor.....	3-8
Fuel and Air Flow.....	3-8
Low Idle Speed Adjustment.....	3-9
High Idle Speed Adjustment.....	3-9
High Altitude Operation.....	3-9
Main Jet Replacement.....	3-9
Fuel system Cleanliness Inspection.....	3-9
Carburetor Removal.....	3-10
Carburetor Installation.....	3-10
Carburetor Disassembly/Assembly.....	3-11
Carburetor Cleaning.....	3-12
Carburetor Inspection.....	3-12
Intake Manifold.....	3-14
Intake Manifold Removal.....	3-14
Intake Manifold Installation.....	3-14
Intake Manifold Inspection.....	3-15
Fuel Pump, Fuel Filter.....	3-16
Fuel Pump Inspection.....	3-16
Fuel Filter Inspection.....	3-16
Air Cleaner.....	3-17
Element Removal.....	3-17
Element Installation.....	3-17
Element Cleaning and Inspection.....	3-17
Cleaner Body Removal.....	3-17
Cleaner Body Installation.....	3-17
Housing (Case and Body) Inspection.....	3-17

3-2 FUEL SYSTEM

Exploded View

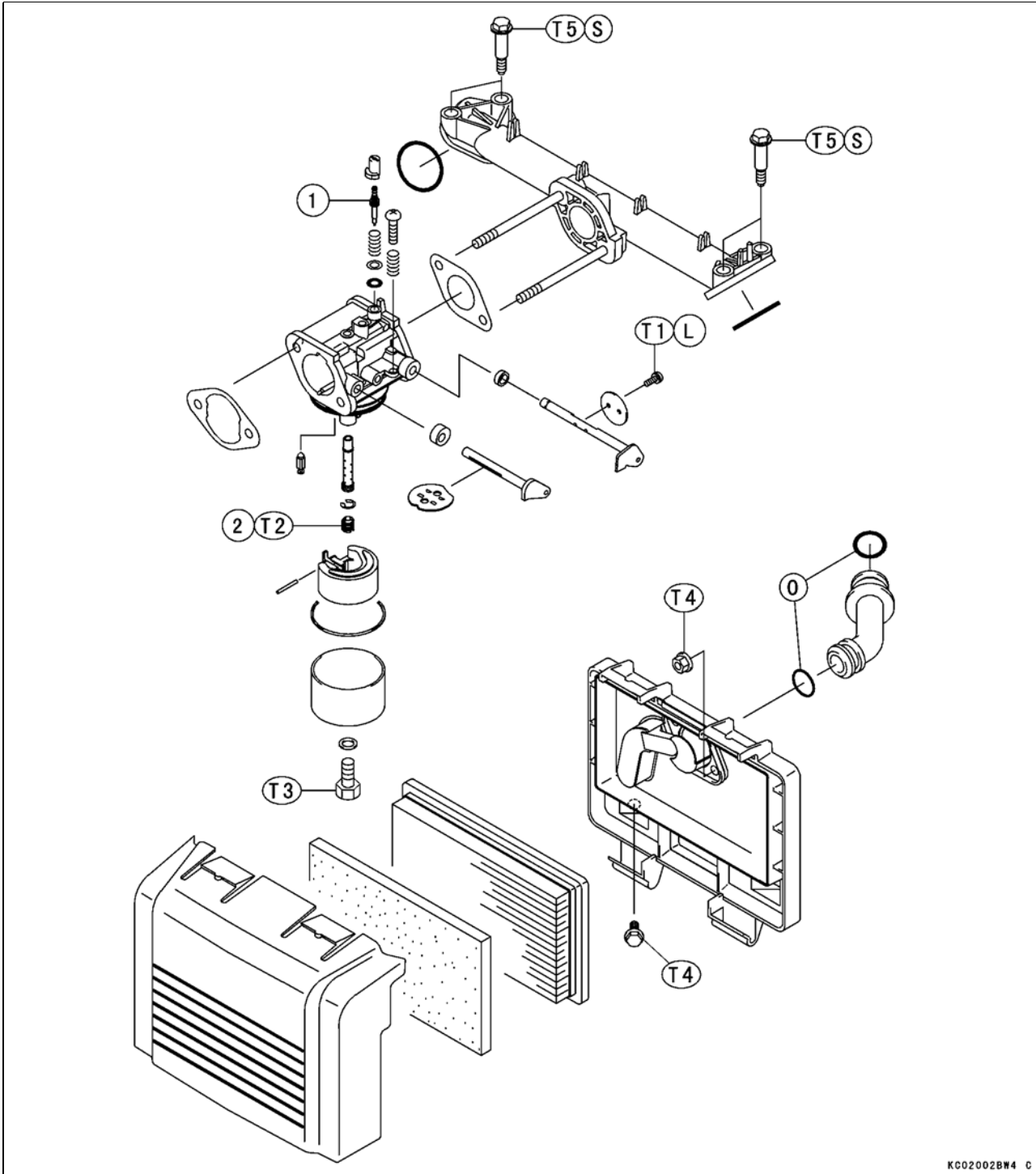

KC02002BW4 C

- 1. Pilot Screw
- 2. Main Jet

- T1: 0.7 N·m (0.07 kgf·m, 6 in·lb)
- T2: 2.3 N·m (0.23 kgf·m, 20 in·lb)
- T3: 4.5 N·m (0.46 kgf·m, 40 in·lb)
- T4: 5.9 N·m (0.60 kgf·m, 52 in·lb)
- T5: 6.9 N·m (0.70 kgf·m, 61 in·lb)

L: Apply non-permanent locking agent.
 O: Apply engine oil.
 S: Follow the specific tightening sequence.

Exploded View

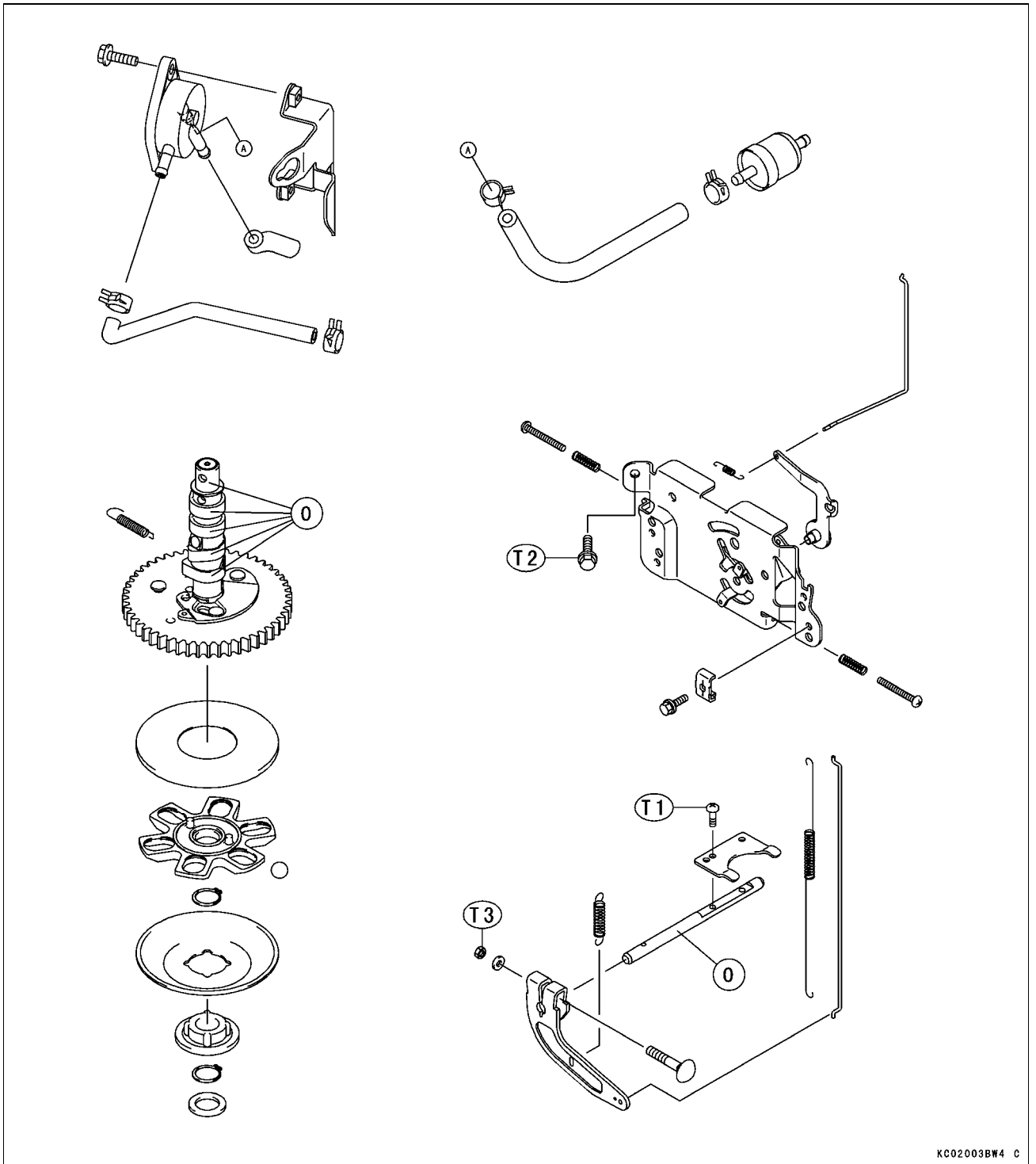

KC02003BW4 C

- T1: 2.0 N·m (0.20 kgf·m , 18 in·lb)
- T2: 5.9 N·m (0.60 kgf·m , 52 in·lb)
- T3: 7.8 N·m (0.80 kgf·m , 69 in·lb)

O: Apply engine oil.

3-4 FUEL SYSTEM

Specifications

Item	Standard	
	FH381V	FH430V
Carburetors Specifications:		
Make/ type	Walbro LMF-2	Walbro LMF-1
Throttle bore diameter	24 mm (0.94 in.)	←
Venturi diameter	14 mm (0.55 in)	16 mm (0.63 in.)
Main Jet (MJ)	#78	#88
Pilot jet (PJ)	#40	←
Pilot air screw turns out (PS) (Idle mixture screw turns out)	1 1/4	1 5/8
Float level	Float parallel to carburetor body	←
Idle Speed: (1)		
Low idle speed	1550 r/min (rpm)	
High idle speed	3600 r/min (rpm)	
Air Cleaner:		
Type	Dual stage filtration system	
Pre-cleaner	Foam element	
Second-stage cleaner	Paper element	
Fuel:		
Fuel requirement	Unleaded regular grade gasoline	
Fuel Pump:		
Type	Pulse-diaphragm pump	
Governor:		
Type	Flyweight all speed governor	

(1) Idle speeds may vary depending on each equipment. Refer to the equipment specification.

Governor Link Mechanism

Control Panel Assembly Removal

- Remove:
 - Air Cleaner (see Cleaner Body Removal)
 - Control Panel Mounting Bolts [A]

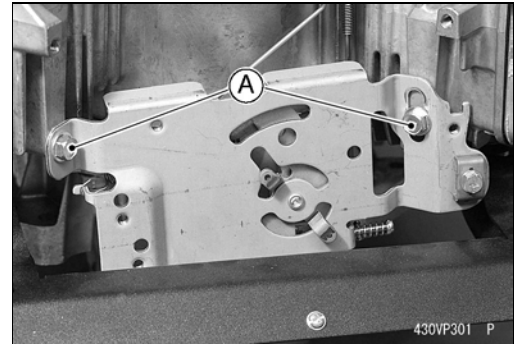

- Remove the control panel assembly [A] while unhooking the governor spring [B] end loop at the panel bracket.
- Clear the choke link rod lower end [C] from the choke lever.

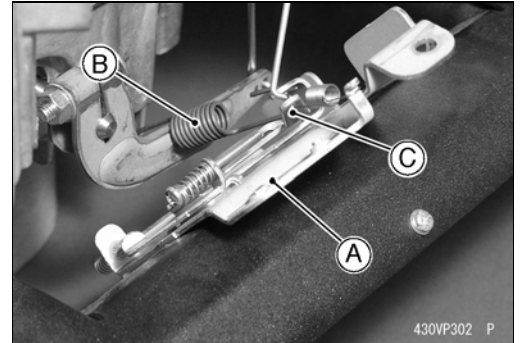

Control Panel Assembly Installation

- Before installing the control panel assembly, check to see that the choke lever [A] and engine speed control lever [B] move smoothly in all directions.
- ★ If any part is worn or damaged, replace the control panel assembly.
- After installation, adjust the low idle speeds and high idle speeds to the specifications (see Periodic Maintenance chapter).

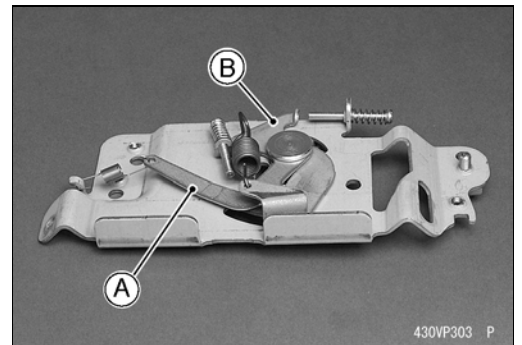

Governor Arm Removal

- Remove:
 - Control Panel Assembly
- Loosen the clamp nut [A] and take off the governor arm [B].
- Unhook the throttle link rod spring [C] end loop and clear the throttle link rod lower end [D].

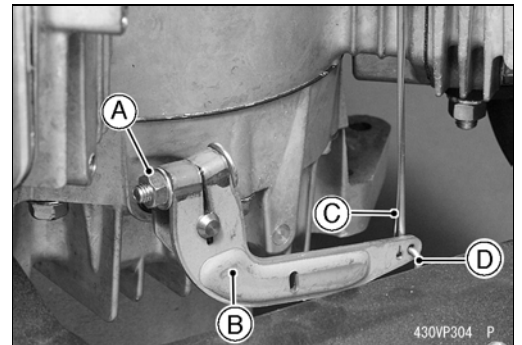

3-6 FUEL SYSTEM

Governor Link Mechanism

Governor Arm Installation

- Install the governor arm [A] onto the governor shaft [B] temporarily.
- Be sure the link spring [C] around the throttle link rod [D] is in place and that it pulls the governor arm and throttle lever [E] toward each other.
- Loosen the clamp nut [F] on the governor arm enough to move the governor shaft.
- Turn the top end of the governor arm counterclockwise to fully open the carburetor [G] throttle valve and hold it there.
- Turn the governor shaft counterclockwise, fully turn the shaft to end of its travel.
- Tighten the clamp nut.

Torque - Governor Arm Clamp Nut: 7.8 N·m (0.80 kgf·m, 69 in·lb)

- Install the control panel assembly, and connect the governor arm with the governor spring.

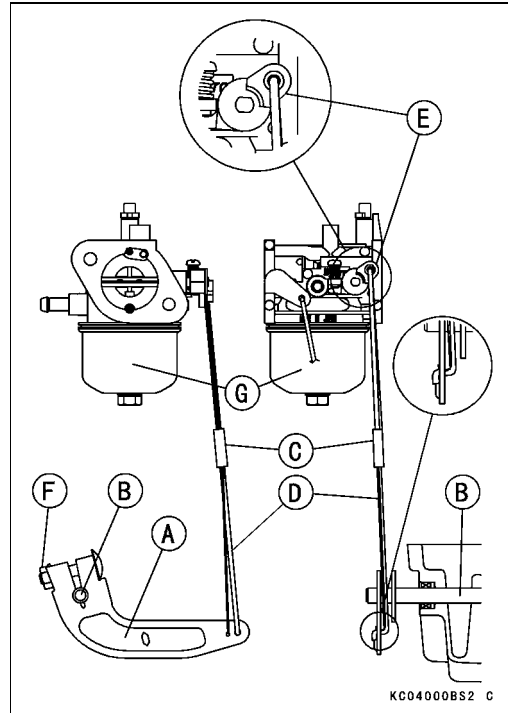

Governor Assembly Removal

- Remove the crankcase cover (see Camshaft/Crankshaft chapter).
- Remove the push rod (see Engine Top End chapter).
- Invert the engine.
- Remove the camshaft [A].

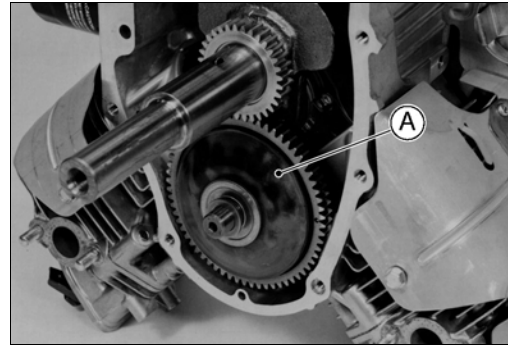

- Remove:
 - Washer [A]
 - Snap Ring [B]
 - Sleeve [C]
 - Governor Plate [D]
 - Snap Ring [B]
 - Steel balls [E]
 - Ball Guide [F]
 - Ball Plate [G]

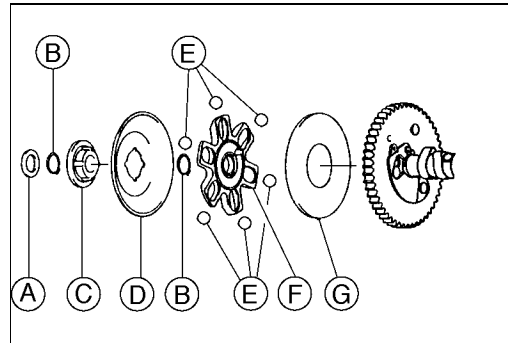

Governor Assembly Installation

- Fit the snap rings [A] into the grooves securely.
- Spin the governor plate by hand and check that the steel balls and governor plate operate freely.

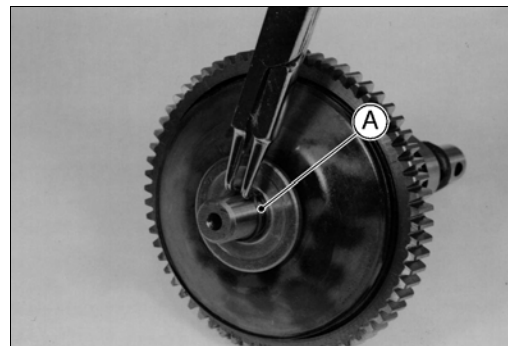

Governor Link Mechanism

Governor Assembly Inspection

- Visually check all governor parts for wear and damage.
- ★ If any parts are worn or damaged, replace them.

Governor Shaft Removal

- Split the crankcase (see Camshaft/Crankcase chapter).
- Unscrew the governor shaft plate screws [A], and pull out the governor shaft [B] outside.

NOTE

- *It is not necessary to remove the governor shaft unless it is being replaced.*
- Replace the oil seal only if the lip shows signs of leakage or it has been damaged.
- The oil seal [A] must be assembled with seal lip towards inside of the engine.
- Press in the oil seal 0 ~ 1.0 mm (0.04 in.) [B] flush or below the crankcase surface [C].

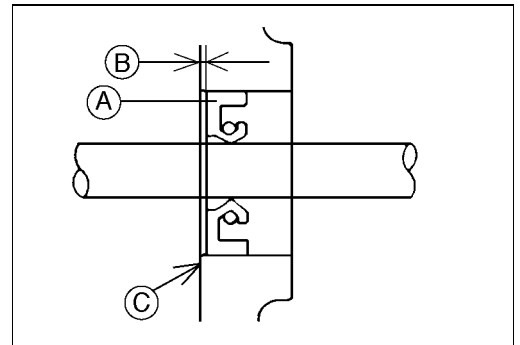
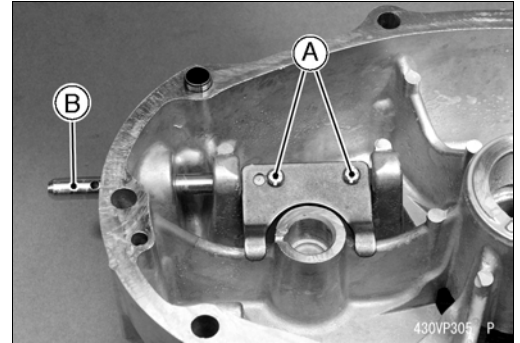

Governor Shaft Installation

- Apply engine oil to the governor shaft.
 - Insert the governor shaft into the crankcase.
 - Install the governor shaft plate [A] to the shaft [B] as shown.
- Torque - Governor Shaft Plate Screws: 2.0 N·m (0.20 kgf·m, 18 in·lb)**
- Check that the governor shaft moves freely in its operating range.

NOTE

- *If the oil seal is removed, oil seal is put on after shaft is installed.*

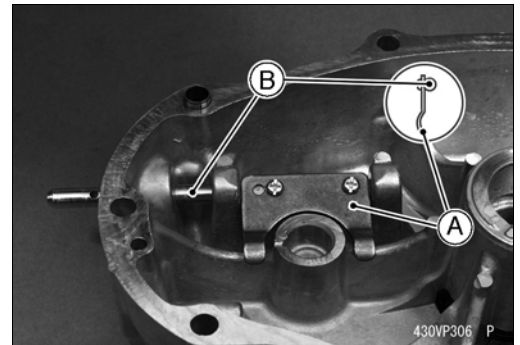

3-8 FUEL SYSTEM

Carburetor

Fuel and Air Flow

The main system of the carburetor consists of the main jet [A], main nozzle [B], and the main air passage [C] (main air jet [D]). The main system meters fuel to the engine during moderate to heavy load conditions. Fuel flows through the main jet and into the main nozzle, where it is joined by air from the main air passage (main air jet). The resulting mixture flows out the end of the main nozzle into the carburetor bore, where it is atomized by the high speed air flow, and carried into the engine.

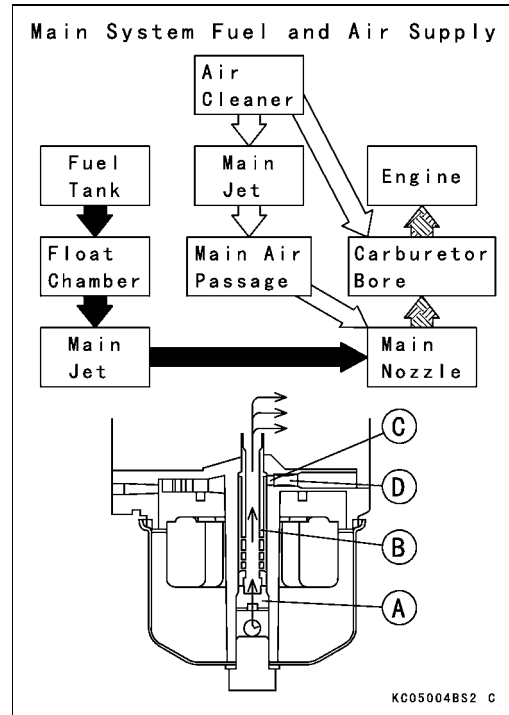

The pilot system includes the pilot jet [E], pilot screw [F] (Idle mixture screw), pilot air jet [G], pilot outlet [H], and the bypass holes [I]. The pilot system meters the fuel/air mixture while the engine is idling and running under a light load. Under these conditions there is very little air flow through the carburetor bore; so little that it is not enough to draw fuel through the main system of the carburetor and atomize it. Instead, the fuel is drawn through the pilot system, since the nearly closed throttle valve [J] causes high speed air flow past the pilot outlet and bypass holes (even at low engine speed).

Fuel flow in the pilot system is metered by the pilot jet. Air for better atomization is admitted via the pilot air jet in the mouth of the carburetor. The fuel/air mixture passes into the bore of the carburetor side stream of the throttle valve through the bypass holes and pilot outlet. While the throttle valve is almost closed, it covers the small bypass holes opening into the bore from the pilot system. As the throttle valve begins to open, it uncovers the bypass holes, allowing more fuel/air mixture to flow. The extra flow is needed because the engine starts to run faster as the throttle is opened. The pilot screw controls the amount of fuel/air mixture allowed through the pilot outlet, but does not meter the bypass holes. A moderate amount of air comes in around the throttle valve at idle, so adjusting the pilot screw changes the fuel/air ratio. Turning the pilot screw (Idle mixture screw) out (Counterclockwise) enriches the mixture; turning it in (clockwise) leans the mixture.

Main Fuel Flow →
Pilot Fuel Flow ⇒

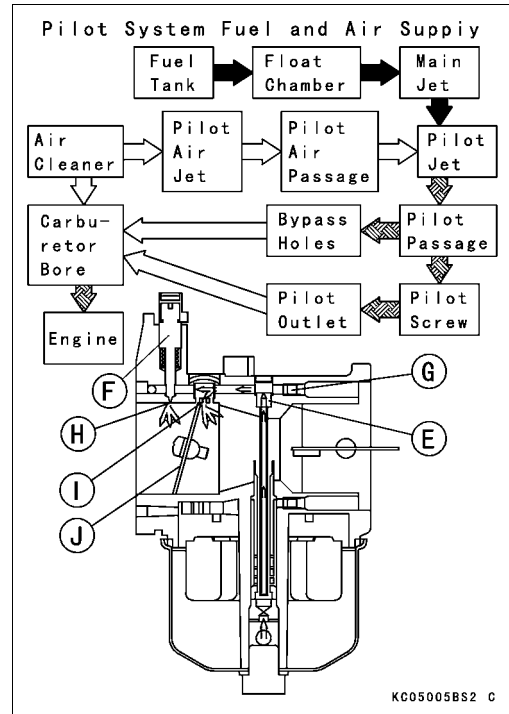

Carburetor

Low Idle Speed Adjustment

- Refer to Low Idle Speed Adjustment in the Periodic Maintenance Chapter (2nd chapter).

High Idle Speed Adjustment

- Refer to High Idle Speed Adjustment in the Periodic Maintenance Chapter (2nd chapter).

High Altitude Operation

At high altitude, the standard carburetor air-fuel mixture will be excessively rich. Performance will decrease, and fuel consumption will increase. High altitude performance can be improved by installing a smaller diameter main-jet in the carburetor and correct idle speed.

NOTE

- The main jet high altitude kits are available if the equipment is to be used in the high altitudes. The main jet numbers are stamped on ends of the main jets.

High Altitude Main Jet

Altitude	Main Jet No.	
	FH380V	FH430V
0 ~ 1 000 m (0 ~ 3 000 ft)	#78	#88
1 000 ~ 2 000 m (3 000 ~ 6 000 ft)	#75	#85
2 000 m (6 000 ft) and higher	#72	#82

Main Jet Replacement

- Place the engine (equipment) on a level surface.
 - Close the fuel shut off valve in the equipment.
 - Remove the carburetor (see Carburetor Removal).
 - Unscrew the float chamber mounting bolt [A] and take off the float chamber [B] and gasket.
-
- Using a properly sized blade screw driver, carefully replace the main jet [A] with a new one for altitude expected.
 - Tighten the main jet to the specification (see Carburetor Disassembly Assembly Notes).
 - Install the float chamber and gasket.
 - Tighten float chamber mounting bolt.

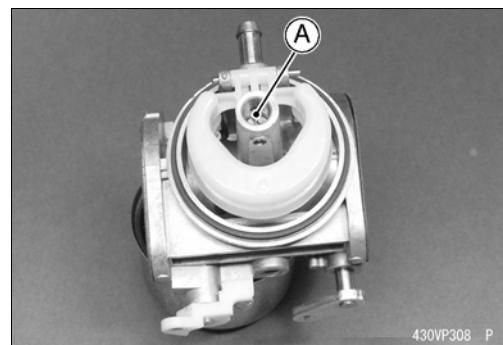
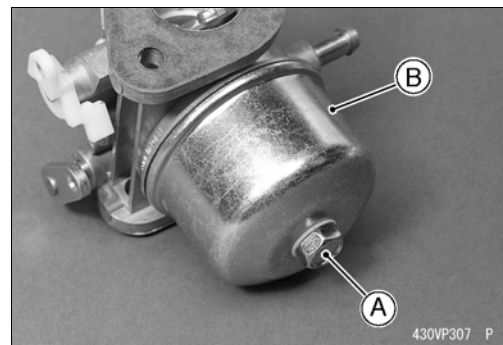

Fuel system Cleanliness Inspection

- Refer to Fuel System Cleanliness Inspection in the Periodic Maintenance Chapter (2nd chapter).

3-10 FUEL SYSTEM

Carburetor

Carburetor Removal

⚠ WARNING

Gasoline is extremely flammable and can be explosive under certain conditions. Turn the ignition switch OFF. Do not smoke. Make sure the area is well-ventilated and free from any source of flame or sparks; this includes any appliance with a pilot light.

- Remove:
 - Air Cleaner and Related Parts (see Cleaner Body).
- Turn the fuel shut off valve to the OFF position.
- Drain the carburetor.
- Disconnect the fuel tube at the fuel inlet joint [A] of the carburetor.
- Unhook the throttle link spring [B] at the throttle shaft lever [C] top end with a long nose pliers.
- Unhook the throttle [D] and choke link rods [E] at the top ends of their arms while pull off the carburetor.

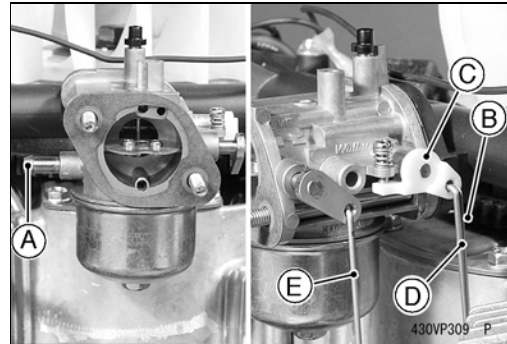

Carburetor Installation

- Clean the mating surfaces of the carburetor and intake manifold, and fit the new gaskets.
- Take care not to bend the throttle and choke link rods during installation. Make sure the link spring around the throttle link rod is in place and that it pulls the governor arm and carburetor throttle shaft lever toward each other.
- Adjust:
 - Carburetor Pilot Screw
 - Idle Speed

Carburetor

Carburetor Disassembly/Assembly

- Refer to the illustration shown for disassembly and assembly.
- There are several passage plugs (Ball plugs) in the carburetor body. Do not remove.
- Before disassembly, mark the out side of choke valve and throttle valves for assembling them.
- Replace the pilot screw in accordance with the following procedure if necessary.
 - Carefully mark the position of the pilot screw limiter on the carburetor body so that it can be installed and set to its original position later.
 - Remove the limiter. Be careful not to turn pilot screw at this point.
 - Turn the pilot screw clockwise and count the number of turns until screw is gently seated in the pilot passage. Record the number of turns needed to closed the screw.
 - Turn out the pilot screw to replace it with a new one.
 - Install the new pilot screw until the screw is gently seated. Then open the screw the same number of turns as recorded prior to removal.
 - Align the limiter with the mark on the carburetor body to install, taking care not to turn the pilot screw.
- Install the choke valve and throttle valve on the shaft as the out side mark of them facing out side.
- Drive the float pin into the carburetor body from the choke valve side.
- Assemble carburetor parts with recommended tightening torque (see Exploded View).

1. Limiter
2. Pilot Screw
3. Spring
4. Washer
5. O-Ring
6. Low Idle Speed Screw
7. Spring
8. Screws
9. Throttle Valve
10. Throttle Shaft
11. Dust Seal
12. Choke Valve
13. Choke Shaft
14. Dust Seal
15. Bolt
16. Gasket
17. Float Chamber
18. Gasket
19. Float Pin
20. Float
21. Main Jet
22. Nozzle Assembly
23. Float Valve

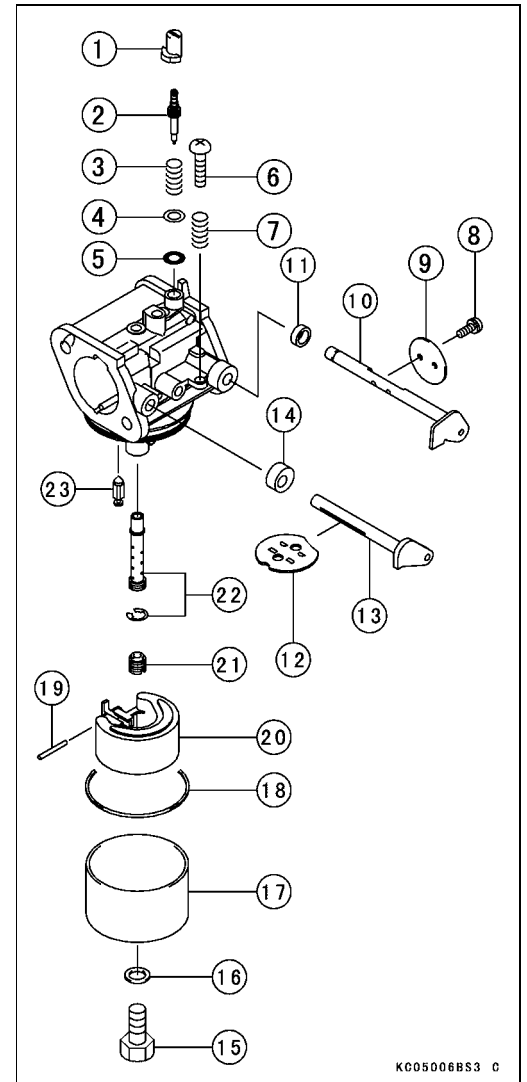

3-12 FUEL SYSTEM

Carburetor

Carburetor Cleaning

⚠ WARNING

Clean the carburetor in a well-ventilated area, and take care that there is no sparks or flame anywhere near the working area; this includes any appliance with a pilot light. Because of the danger of highly flammable liquids, do not use gasoline or low flash-point solvents to clean the carburetors.

CAUTION

Do not use compressed air on an assembled carburetor, or the floats may be crushed by the pressure.

Remove as many rubber or plastic parts from the carburetor as possible before cleaning the carburetor with a cleaning solution. This will prevent to damage or deterioration of the parts.

The carburetor body has plastic parts that cannot be removed. Do not use a strong carburetor cleaning solution which could attack these parts; instead, use a mild high flash-point cleaning solution safe for plastic parts.

Do not use wire or any other hard instrument to clean carburetor parts, especially jets, as they may be damaged.

- Disassemble the carburetor.
- Immerse all the carburetor metal parts in a carburetor cleaning solution and clean them.
- Rinse the parts in water and dry them with compressed air.
- Do not use rags or paper to dry parts. Lint may plug the holes or passages.
- Blow air through the holes and fuel passages with the compressed air. All holes must be open.
- Assemble the carburetor.

Carburetor Inspection

⚠ WARNING

Gasoline is extremely flammable and can be explosive under certain. Turn the ignition switch OFF. Do not smoke. Make sure the area is well ventilated and free from any source of flame or sparks; this includes any appliance with a pilot light.

- Inspect the carburetor body for damage. Flange sealing surfaces should be smooth and free of burrs and nicks. Replace the gasket if necessary.
- Turn the throttle and choke shafts to check that the throttle and choke butterfly valves move smoothly.
- ★ If the valves do not move smoothly, replace the carburetor body and/or throttle shaft and choke shaft assembly.
- Check the gasket on the carburetor body.
- ★ If the gasket is not in good condition, replace it.
- Check the other parts of the carburetor for wear or damage. Replace the part if necessary.
- Clean and check the float level as follows.

CAUTION

Do not push down on the float during float level checking.

Carburetor

- With the float [A] assembly installed onto the carburetor body [B], hold the carburetor upside down at eye level. Gently support the float with a finger and bring it down slowly so that the float arm tab [C] just touches the float valve [D]. The float lower surface [E] should be parallel with the carburetor body mating surfaces [F].
- ★ If the float position is not correct, replace the float with a new one.

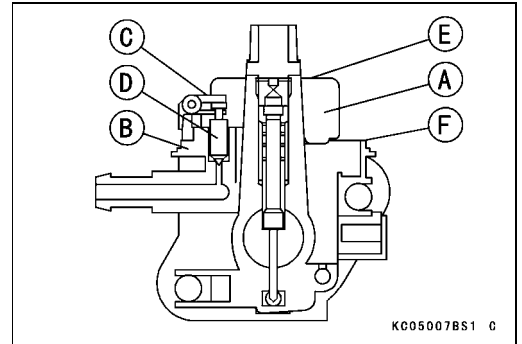

- Inspect the float valve for excessive wear or damage. The tip should be smooth, without any grooves, scratches, or tears. The rod at the other end of the needle should move smoothly when push in and released.
- ★ If either the needle or the seat is worn or damaged, replace the float assembly and carburetor body as a set.

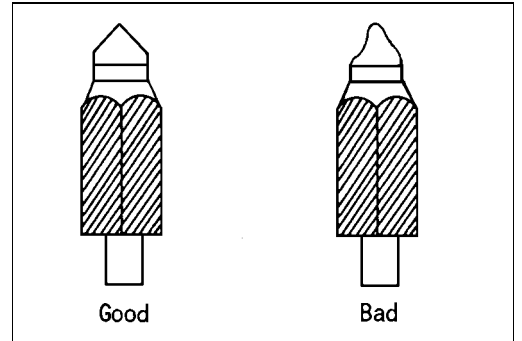

- Inspect the tapered portion [A] of the pilot screw [B] for wear or damage.
- ★ If the pilot screw is worn or damaged on the tapered portion, replace it.
- Check the spring for weakened condition, replace it, if necessary.

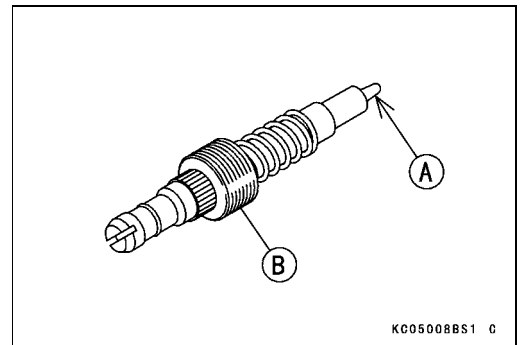

3-14 FUEL SYSTEM

Intake Manifold

Intake Manifold Removal

- Remove:
 - Air Cleaner (see Cleaner Body Removal)
 - Engine Upper Cover
 - Carburetor (see Carburetor Removal)
- Remove the harness from the clamps [A] on the intake manifold.
- Unscrew the manifold mounting bolts [B].

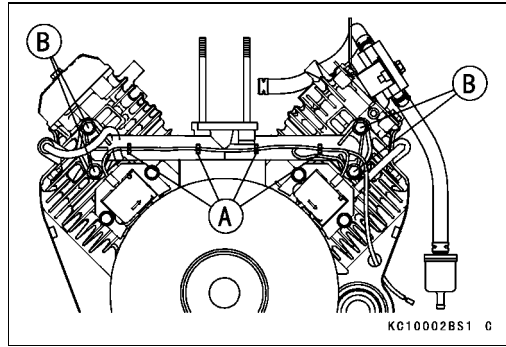

Intake Manifold Installation

- Replace the O-rings [A] with new ones.
- Clean the mating surfaces of the cylinders and intake manifolds.

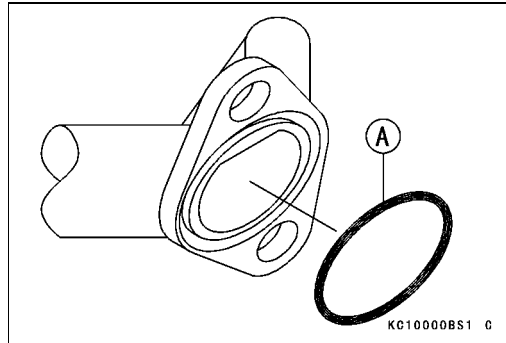

- Clean the mating surfaces of the carburetor and intake manifold and install the new gaskets [A] and intake manifold.

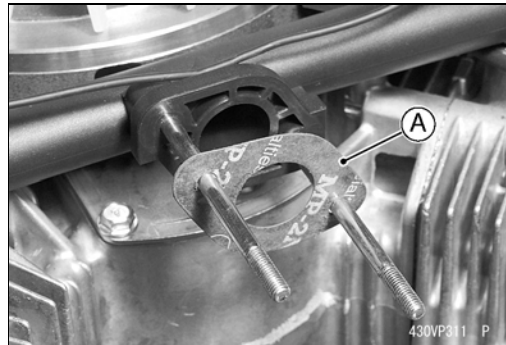

- Tighten the mounting bolts following the tightening sequence.
Torque - Intake Manifold Mounting Bolts: 6.9 N·m (0.70 kgf·m, 61 in·lb)

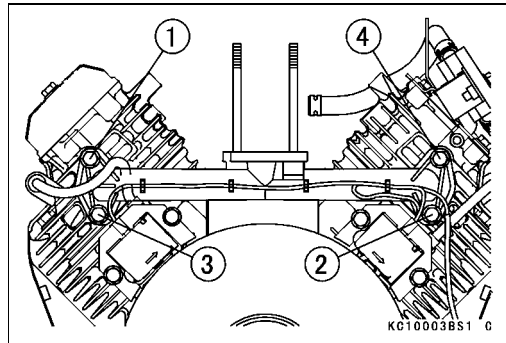

- Fasten the harness [A] into the clamps [B] on the intake manifold [C].
- Position the harness on top of the manifold as shown.
- Install the other removed parts.

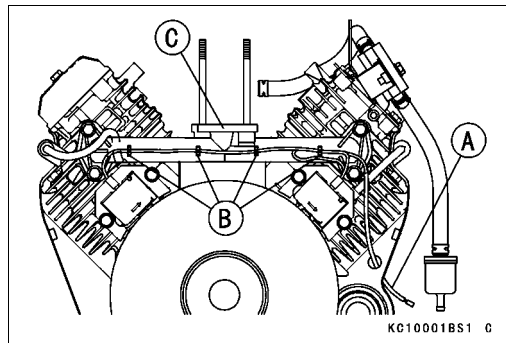

Intake Manifold

Intake Manifold Inspection

- Inspect the intake manifold for cracks.
- Cracks not visible to the eye may be detected by using a metal crack detection system. (Visual color check: commonly found at automotive parts store.)
- ★ If a crack is present in the intake manifold, replace it.
- Inspect the gasket surfaces for burrs and nicks.

3-16 FUEL SYSTEM

Fuel Pump, Fuel Filter

The fuel pump cannot be disassembled, if any damage to the pump is noticed replace it with a new one.

Fuel Pump Inspection

- Refer to Fuel Pump Inspection in the Periodic Maintenance Chapter (2nd chapter).

Fuel Filter Inspection

- Refer to Fuel Filter Inspection in the Periodic Maintenance Chapter (2nd chapter).

Air Cleaner

Element Removal

- Refer to Air Element Removal in the Periodic Maintenance Chapter (2nd chapter).

Element Installation

- Refer to Air Element Installation in the Periodic Maintenance Chapter (2nd chapter).

Element Cleaning and Inspection

- Refer to Air Element Cleaning and Inspection in the Periodic Maintenance Chapter (2nd chapter).

Cleaner Body Removal

- Remove the elements (see Periodic Maintenance chapter).
- Remove the cleaner body mounting bolts [A] and holder plate nuts [B].

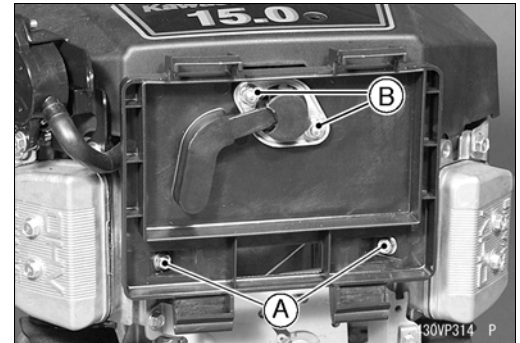

- Pull the breather tube [A] off the pipe at the back of the body, and remove the cleaner body [B].

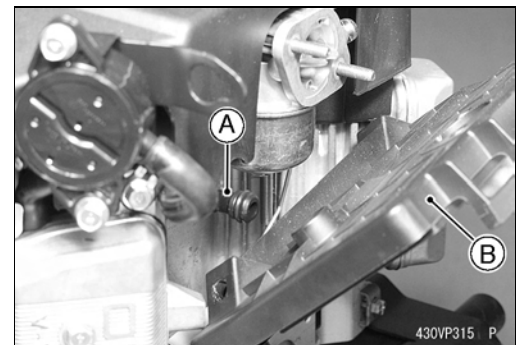

Cleaner Body Installation

- Connect the breather tube from the crankcase to the pipe at the back of the cleaner body.
- Tighten the holder plate nuts and cleaner body mounting bolts.

Torque - Holder Plate Nuts: 5.9 N·m (0.60 kg·m, 52 in·lb)
Cleaner Body Mounting Bolts 5.9 N·m (0.60 kg·m, 52 in·lb)

Housing (Case and Body) Inspection

- Refer to Air Cleaner Housing (Case and Body) Inspection in the Periodic Maintenance Chapter (2nd chapter).

Cooling System

Table of Contents

Exploded View.....	4-2
Cooling Fan.....	4-3
Cooling Fan Removal.....	4-3
Cooling Fan Installation.....	4-3
Cooling Fan Inspection.....	4-3

4-2 COOLING SYSTEM

Exploded View

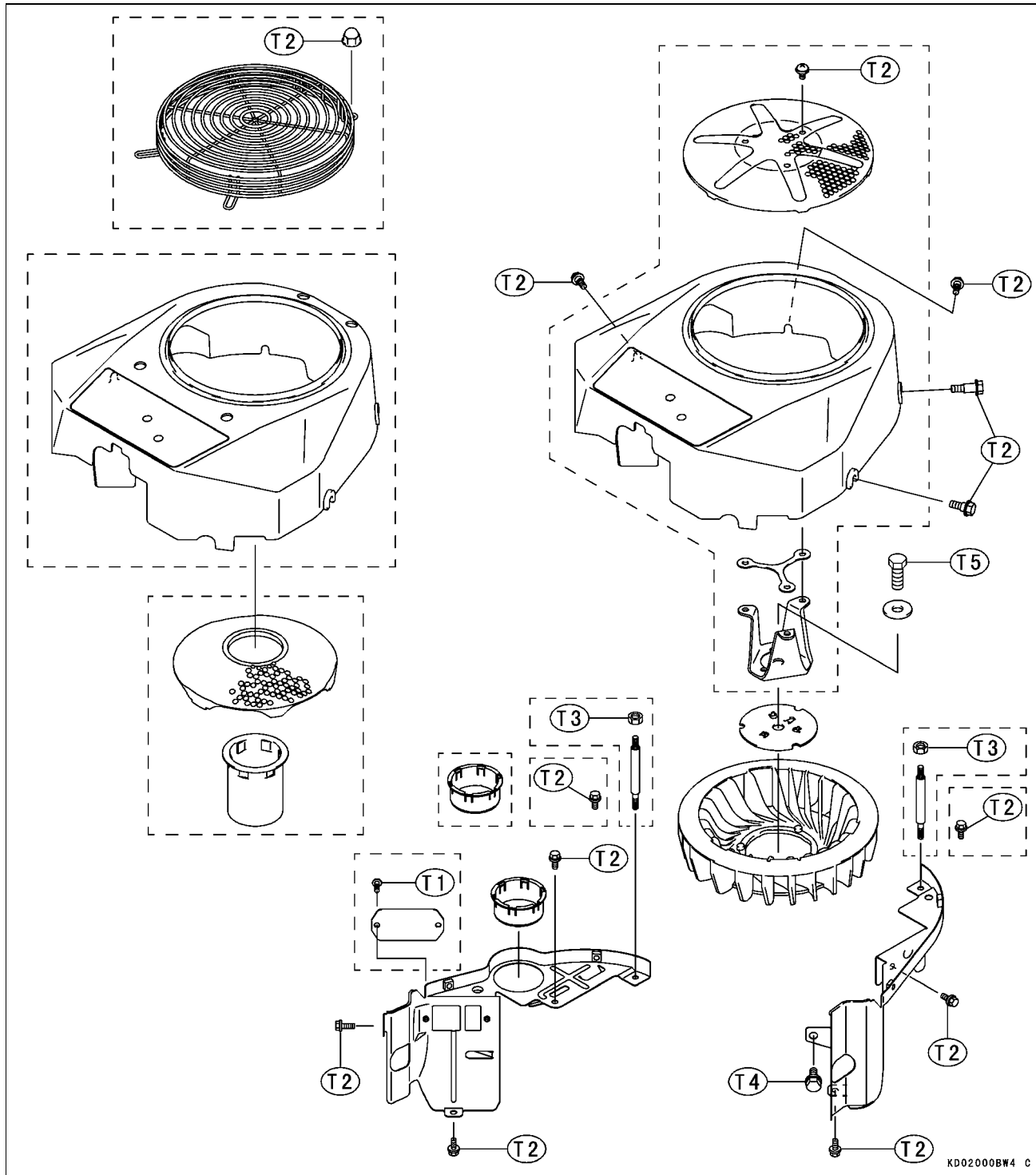

- T1: 3.4 N·m (0.35 kgf·m, 30 in·lb)
- T2: 5.9 N·m (0.60 kgf·m, 52 in·lb)
- T3: 7.8 N·m (0.80 kgf·m, 69 in·lb)
- T4: 15 N·m (1.5 kgf·m, 11 ft·lb)
- T5: 56 N·m (5.7 kgf·m, 41 ft·lb)

Cooling Fan

Cooling Fan Removal

- Refer to Flywheel Removal in Electrical System Chapter.

Cooling Fan Installation

- Refer to Flywheel Installation in Electrical System Chapter.

Cooling Fan Inspection

- Visually inspect the blades [A] in the cooling fan [B].
- ★ If there are any cracks, warps or damage, replace the cooling fan.
- ★ If any mud or dust has stuck to the cooling fan, clean it.
- Cooling fan is cleaned by washing in detergent and water.

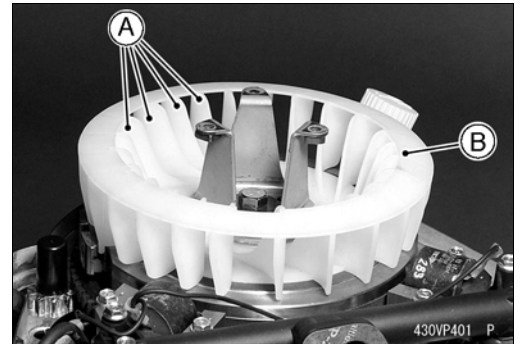

CAUTION

Do not clean the cooling fan in oil solvent. It may be damaged by oil solvent.

Engine Top End

Table of Contents

Exploded View.....	5-2
Specifications.....	5-4
Cylinder Head.....	5-5
Compression Measurement.....	5-5
Cylinder Head Assembly Removal.....	5-6
Cylinder Head Assembly Installation.....	5-6
Push Rod Removal.....	5-7
Push Rod Installation.....	5-7
Push Rod Inspection.....	5-8
Valve Mechanism Removal/Installation.....	5-8
Cleaning and Inspection.....	5-9
Rocker Arm Inspection.....	5-9
Valves.....	5-10
Valve Clearance Inspection.....	5-10
Valve Clearance Adjustment.....	5-10
Valve Seat Inspection.....	5-10
Valve Seat Repair.....	5-10
Valve Head Thickness.....	5-10
Valve Stem Runout.....	5-10
Valve Stem Diameter.....	5-10
Valve Guide Inside Diameter.....	5-10
Valve Spring Inspection.....	5-11
Cylinder, Piston.....	5-12
Piston Removal.....	5-12
Piston Installation.....	5-13
Piston/Cylinder Seizure.....	5-14
Piston Cleaning.....	5-15
Piston Ring and Ring Groove Wear.....	5-15
Piston Ring End Gap.....	5-16
Piston Pin, Piston Pin Hole, and Connecting Rod Wear.....	5-16
Piston Diameter.....	5-17
Cylinder Inside Diameter.....	5-17
Cylinder Boring and Honing.....	5-17
Muffler/Exhaust Pipe Installation.....	5-19
Muffler/Exhaust Pipe Removal.....	5-19
Muffler/Exhaust Pipe Installation.....	5-19
Inspection.....	5-19

5-2 ENGINE TOP END

Exploded View

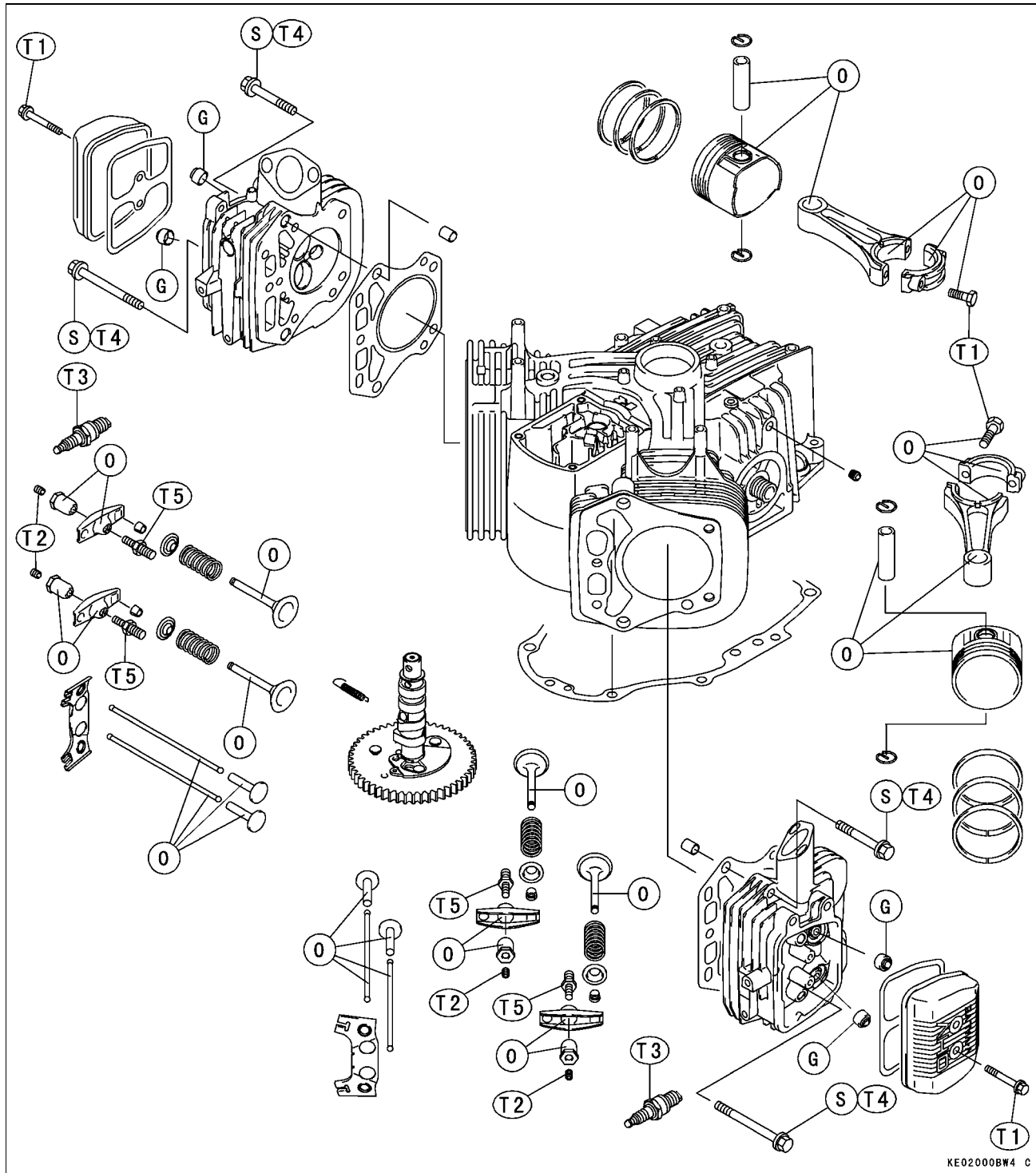

KE02000BW4 C

- T1: 5.9 N·m (0.60 kgf·m, 52 in·lb)
- T2: 6.9 N·m (0.70 kgf·m, 61 in·lb)
- T3: 22 N·m (2.2 kgf·m, 16 ft·lb)
- T4: 25 N·m (2.6 kgf·m, 19 ft·lb)
- T5: 28 N·m (2.8 kgf·m, 20 ft·lb)

- O: Apply engine oil.
- G: Apply grease.
- S: Follow the specific tightening sequence.

Exploded View

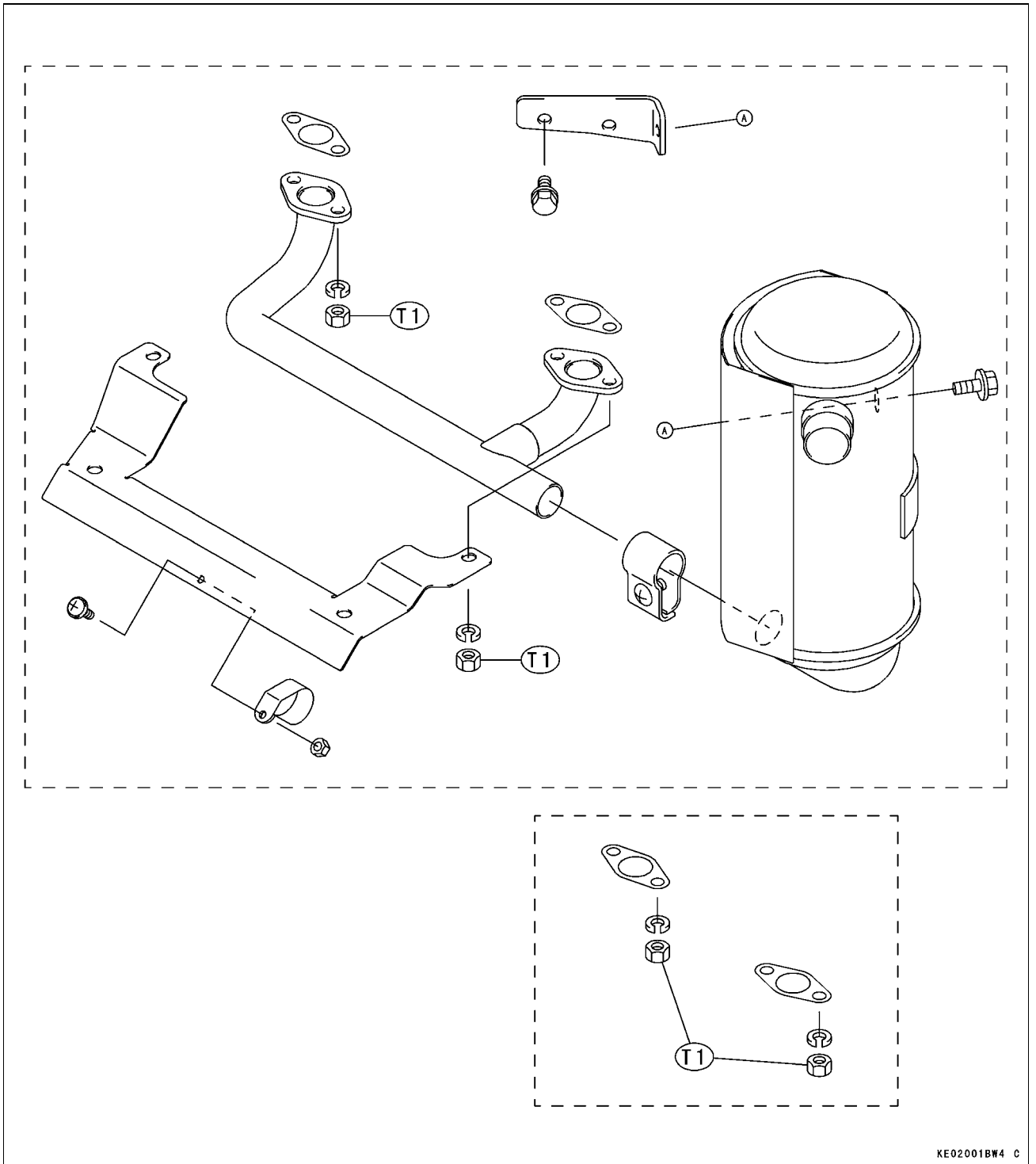

T1: 15 N·m (1.5 kgf·m, 11 ft·lb)

5-4 ENGINE TOP END

Specifications

Item	Service Limit
Cylinder Head:	
Cylinder compression (MIN)	[390 kPa (57 psi)] (MIN)
Cylinder head warp	0.03 mm (0.001 in.)
Valves:	
Valve head thickness	Intake, Exhaust 0.35 mm (0.014 in.)
Valve stem runout	Intake, Exhaust 0.05 mm (0.002 in.)
Valve stem diameter	Intake 5.95 mm (0.0234 in.)
	Exhaust 5.93 mm (0.0233 in.)
Valve guide inside diameter	Intake, Exhaust 6.08 mm (0.239 in.)
Valve spring free length	Intake, Exhaust 31.5 mm (1.24 in.)
Rocker arm push rod runout	Intake, Exhaust 0.5 mm (0.02 in.)
Cylinder, Piston	
Piston diameter	64.79 mm (2.551 in.)
Piston ring/groove clearance	Top 0.18 mm (0.007 in.)
	Second 0.18 mm (0.007 in.)
Piston ring thickness	Top, Second 1.40 mm (0.055 in.)
Piston ring end gap	Top 0.75 mm (0.029 in.)
	Second 0.75 mm (0.029 in.)
	Oil 1.05 mm (0.041 in.)
Piston pin outside diameter	15.96 mm (0.628 in.)
Piston pin hole inside diameter	16.08 mm (0.633 in.)
Connecting rod small end inside diameter	16.05 mm (0.632 in.)
Cylinder inside diameter:	Standard Cylinder 65.10 mm (2.563 in.)
	0.50 mm Oversize 65.60 mm (2.583 in.)
Cylinder bore out round	0.056 mm (0.0022 in.)

Item	Standard
Valve clearance	Intake, Exhaust 0.10 ~ 0.15 mm (0.004 ~ 0.006 in.)
Valve seating surface angle	Intake, Exhaust 45°
Valve seating surface width	Intake, Exhaust 0.6 ~ 0.9 mm (0.024 ~ 0.035 in.)
Valves guide inside diameter	Intake, Exhaust 6.00 ~ 6.012 mm (0.2362 ~ 0.2367 in.)
Cylinder bore diameter standard cylinder	
Standard cylinder	65.00 ~ 64.98 mm (2.559 ~ 2.558 in.)
0.50 mm Over size	65.50 ~ 65.48 mm (2.579 ~ 2.578 in.)

Special Tools - Compression Gauge : 57001 - 221
Compression Gauge Adapter M14 x 1.25: 57001-1159
Piston Ring Pliers: 57001 - 115
Piston Ring Compression Grip: 57001 - 1095
Piston Ring Compression Belt, ϕ 55 - ϕ 67: 57001-1096
Valve Seat Cutter Holder Bar: 57001-1128
Valve Seat Cutter Holder, ϕ 6: 57001-1360
Valve Seat Cutter, 45° - ϕ 27.5 : 57001-1114
Valve Seat Cutter, 32° - ϕ 28.0 : 57001-1119
Valve Seat Cutter, 32° - ϕ 25.0 : 57001-1118

Cylinder Head

Compression Measurement

- Before measuring compression, do the following:
 - Be sure the battery is fully charged.
 - Thoroughly warm up the engine so that engine oil between the piston and cylinder wall will help seal compression as it does during normal running.
 - Stop the engine.
- Disconnect the spark plug caps of each cylinder and remove the spark plugs.
- Attach the compression gauge assembly firmly into one plug hole.

Special Tools - Compression Gauge: 57001-221 [A]

Compression Gauge Adapter: 57001-1159 [B]

- Ground the spark plugs to the engine.

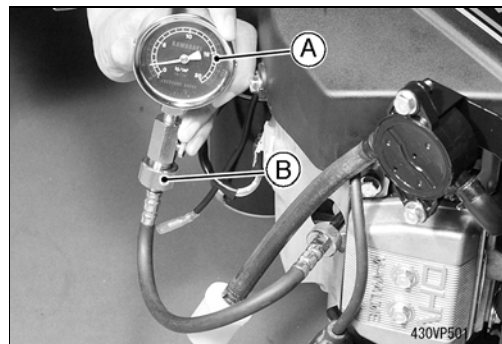

⚠ WARNING

To avoid fire, do not ground the spark plugs in proximity to the plug holes. Keep the plugs as far away as possible from the plug holes.

- With the throttle fully open, turn engine over with the recoil starter several times until the compression gauge stops rising; the compression is the highest reading obtainable. (Recoil Starter Model)

Cylinder Compression (MIN) 390 kPa (57 psi)

- Using the starter motor, turn the engine over with the throttle fully open until the compression gauge stops rising; (Electric Starter Model).

Cylinder Compression (MIN) 390 kPa (57 psi)

- Cylinder compression reaches more than 1000 kpa (145 psi) in a case when cranking speed is over 700 rpm.
- Repeat the measurement to the other cylinder.
- ★ If the compression is higher than the specified value, the piston rings, cylinder and valves are probably in good condition.
- ★ If the compression is too high, check the following.
 1. Carbon build-up on the piston crown and cylinder head - clean off any carbon on the piston crown and cylinder head.
 2. Cylinder head gasket - use only the proper gasket. The use of a gasket of incorrect thickness will change the compression.
 3. Valve guides and piston rings - rapid carbon accumulation in the combustion chamber may be caused by worn valve guides and/or worn piston oil rings. This may be indicated by white exhaust smoke.
- ★ If cylinder compression is lower than the (MIN), check the following:
 1. Gas leakage around the cylinder head - replace the damaged gasket and check and check the cylinder head warp.
 2. Condition of the valve seating.
 3. Valve clearance.
 4. Piston/cylinder wear, piston seizure.
 5. Piston ring, piston ring groove.

5-6 ENGINE TOP END

Cylinder Head

Cylinder Head Assembly Removal

- Remove:
 - Air Cleaner and Carburetor (see Fuel System chapter)
 - Muffler (see Muffler Exhaust Pipe Removal)
 - Intake Manifold (see Fuel System chapter)
 - Spark Plug
- Unscrew the rocker cover mounting bolts [A], and remove the cover [B] and gasket.

- When removing the #1, #2 cylinder head, set each cylinder at T.D.C [A] of power stroke in.

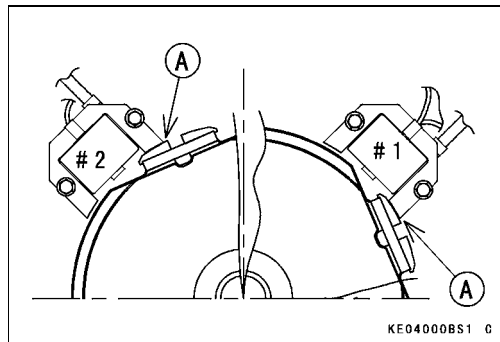
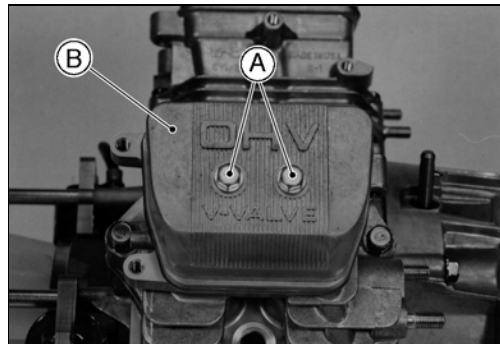

- Loosen the cylinder head bolts 1/4 turn in the sequence shown.

CAUTION

If the above procedure is not followed, the cylinder head may be warped during removal.

- Repeat the sequence until all bolts are removed and lift off the cylinder head assembly.

NOTE

- Mark the push-rods so they can be installed in their original position during assembly.

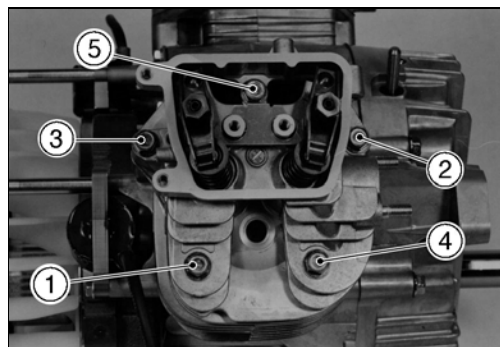

Cylinder Head Assembly Installation

- Clean the mating surfaces of the cylinder heads and cylinder.
- Install the push rods in their original positions on each cylinder (see Push Rod Installation).
- Install the knock pins.
- Set each cylinder at T.D.C [A] of power stroke in.
- Put new gaskets and the cylinder head assemblies on each cylinder, then align the push rods under the rocker arms.

NOTE

- Because the head gaskets are coated with sealing agents, be careful not to damage the surfaces.

- Tighten the cylinder head bolts following the tightening sequence.

Torque - Cylinder Head Bolts: 25 N·m (2.6 kgf·m, 19 ft·lb)

CAUTION

A torque wrench must be used to assure proper torque. Improper tightening of the head bolts can result in warping of the cylinder head.

- Check and adjust the valve clearance.
- Install the gasket and rocker cover.
 - Torque - Rocker Cover Mounting Bolts: 5.9 N·m (0.60 kgf·m, 52 in·lb)**
- Install the other removed parts.

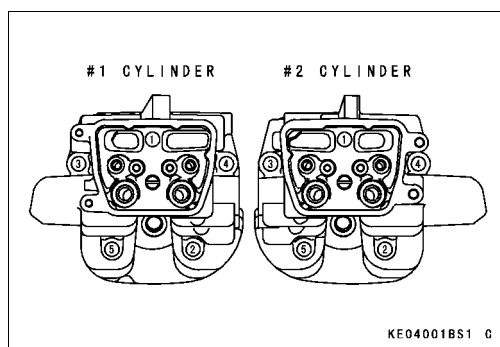
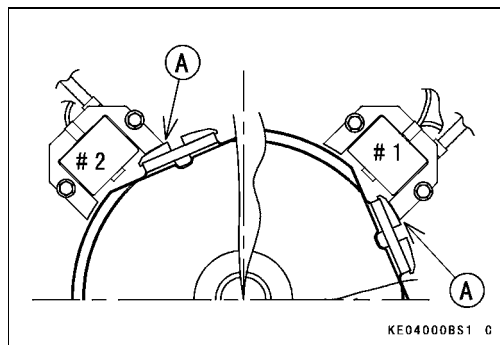

Cylinder Head

Push Rod Removal

- Set each cylinder at T.D.C of power stroke.
- Remove the rocker covers (see Cylinder Head Assembly Removal).
- Loosen the valve clearance adjusting nuts [A].
- Move the rocker arms [B] to clear the push rod upper ends.
- Pull out the push rods.

NOTE

- Mark the push rods so they can be installed in their original position during assembly.

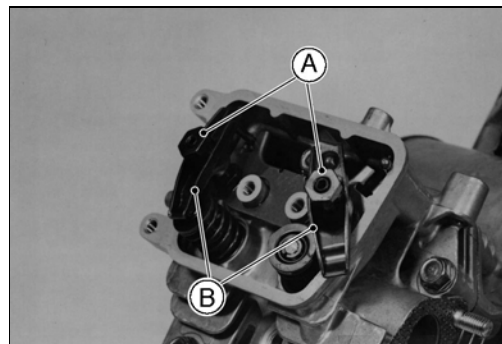

Push Rod Installation

- Set each cylinder at T.D.C of power stroke.
- Install the push rods [A] in their original positions on each cylinder.
- To Install the push rod in the correct position on the tappet [B], insert the push rod so end of the push rod is sliding down [C] along inside wall [D] of the crankcase and position the push rod end onto the tappet.
- Check that both intake and exhaust push rods on each cylinder are at lowest position on the cam lobes [E], if not, turn the flywheel clockwise one turn (360°) and reset each cylinder at T.D.C of power stroke in.
- Be sure the end of the push rods are correctly seated on the tappets.
- Tighten the valve clearance adjusting nuts.
- Check and adjust the valve clearance.

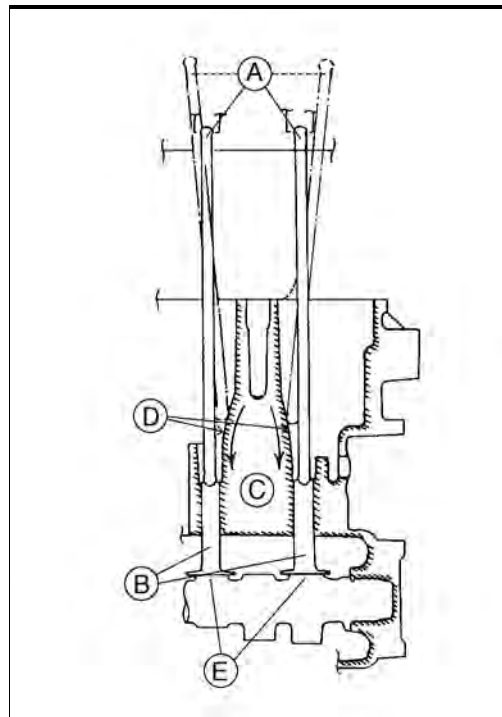

5-8 ENGINE TOP END

Cylinder Head

Push Rod Inspection

- Place the rocker arm push rod in V blocks that are as far apart as possible, and set a dial gauge on the rod at a point halfway between the blocks. Turn the rod to measure the runout. The difference between highest and the lowest dial readings is the amount of runout.
- ★ If the runout exceeds the service limit, replace the rod.

Rocker Arm Push Rod Runout Service Limit: 0.5 mm (0.02 in.)

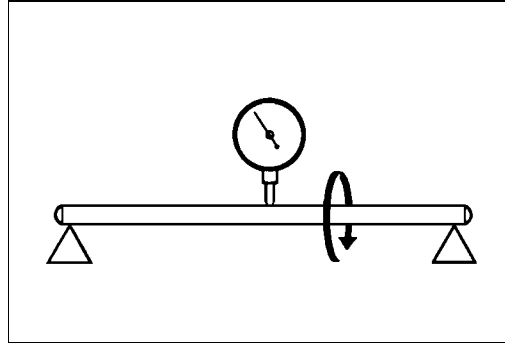

Valve Mechanism Removal/Installation

- Remove the cylinder head assembly (see Cylinder Head Assembly Removal).

NOTE

- When removing the valve mechanism parts, note their position so that they may be reinstalled in their original position during assembly.
- Remove:
 - Valve Clearance Adjusting Nuts [A]
 - Rocker Arms [B]
- Support the valve head in the combustion chamber with a suitable block.
- To remove the collets [A], push down the valve retainer [B] with thumbs and remove the Collets.
- Remove the spring [C] and valve [D].

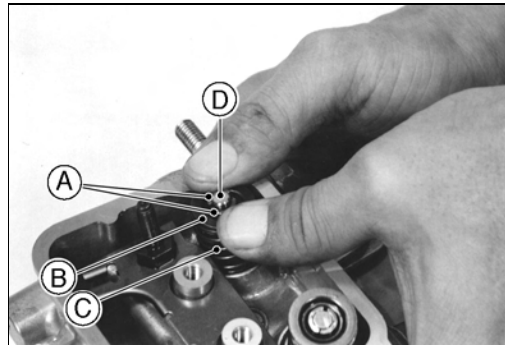
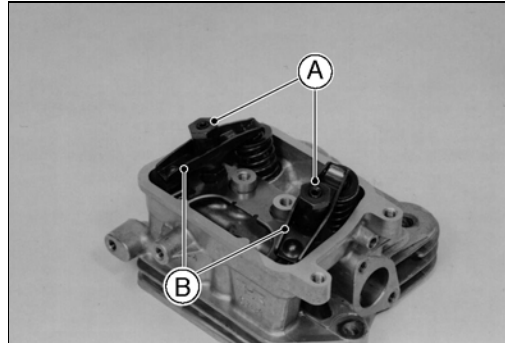

- Remove the stem seals [A].

NOTE

- It is not necessary to remove the stem seal unless it is being replaced.
- Valve guide [B] is not replaceable, do not remove it.

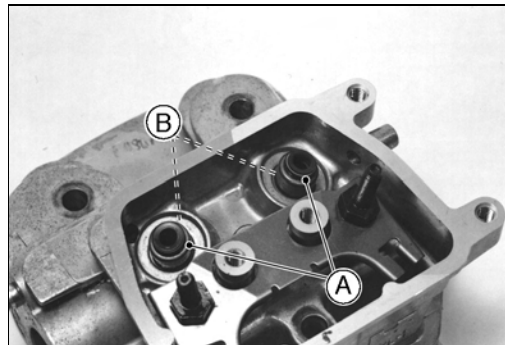

- Valve Installation.
 - Apply engine oil to the valve stem to avoid damaging the stem seal.
 - Check to see that the valve moves smoothly up and down in the guide.
 - Check the valve seating surface [A] between the valve [B] and valve seat [C].
- Rocker Arm Installation
 - Soak the valve clearance adjusting nuts and rocker arm in the engine oil.
 - Install the rocker arm.

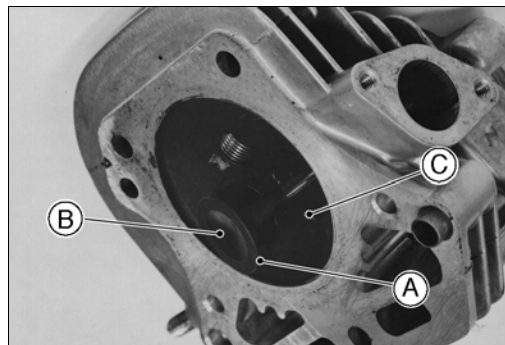

Cylinder Head

Cleaning and Inspection

- Refer to Cylinder Head Cleaning and Inspection in the Periodic Maintenance Chapter (2nd chapter).

Rocker Arm Inspection

- Clean and inspect the rocker arm where it touches the push rod and valve stem.
- ★ If the contact points [A] are worn or damaged, replace the rocker arm.

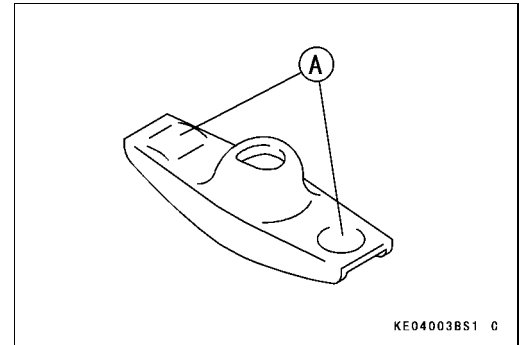

5-10 ENGINE TOP END

Valves

Valve Clearance Inspection

- Refer to Valve Clearance Inspection in the Periodic Maintenance Chapter (2nd chapter).

Valve Clearance Adjustment

- Refer to Valve Clearance Adjustment in the Periodic Maintenance Chapter (2nd chapter).

Valve Seat Inspection

- Refer to Valve Seat Inspection in the Periodic Maintenance Chapter (2nd chapter).

Valve Seat Repair

- Refer to Valve Seat Repair in the Periodic Maintenance Chapter (2nd chapter).

Valve Head Thickness

- Remove the valve (see Valve Mechanism Removal/Installation).
- Measure the thickness of the valve head.
- ★ If the valve head thickness (valve margin) [A] is less than the service limit, replace the valve.

Valve Head Thickness
Service Limit (IN, EX): **0.35 mm (0.014 in)**

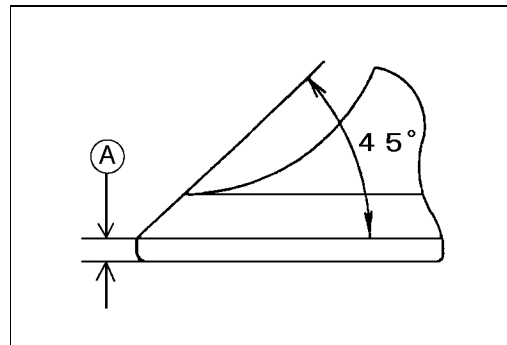

Valve Stem Runout

- Support the valve in V blocks at each end of the stem.
- Position a dial gauge perpendicular to the stem.
- Turn the valve and read the variation on the dial gauge.
- ★ If the stem runout is greater than service limit, replace the valve.

Valve Stem Runout
Service Limit (IN, EX): **0.05 mm (0.002 in.)**

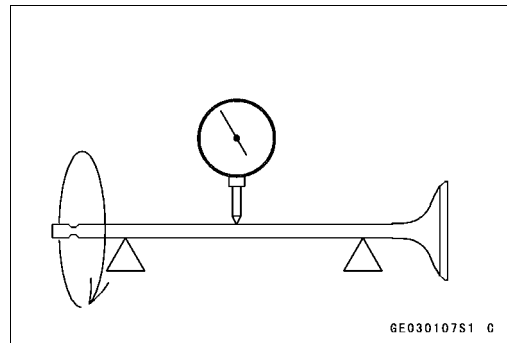

Valve Stem Diameter

- Measure the diameter of the valve stem [A] in two directions at right angles, at four different positions on the stem.
- ★ If any single measurement is less than the service limit, replace the valve.

Valve Stem Diameter
Service Limit:
Intake: **5.95 mm (0.234 in.)**
Exhaust: **5.93 mm (0.233 in.)**

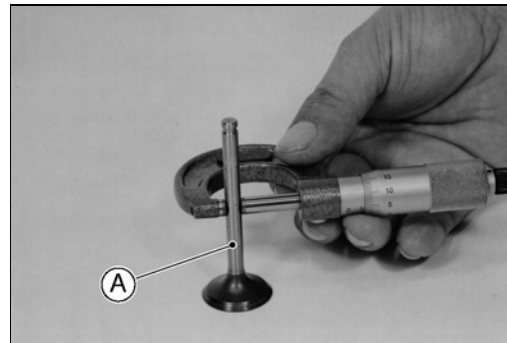

Valve Guide Inside Diameter

- Use a small bore gauge or a micrometer to measure the inside diameter [A] of the valve guide [B] at three places down the length of the guide.
- ★ If the measurement is more than the service limit, replace the cylinder head with a new one.

Valve Guide Inside Diameter
Service Limit:
Intake, Exhaust **6.08 mm (0.239 in.)**

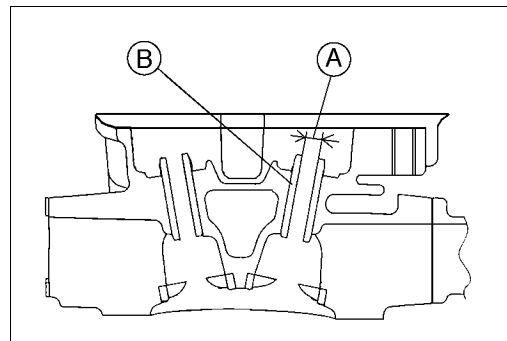

Valves

Valve Spring Inspection

- Inspect the valve spring for pitting, cracks, rusting, and burns.
Replace the spring if necessary.
- Measure the free length [A] of the spring.
- ★ If the measurement is less than the service limit, replace the spring.

Valve Spring Free Length

Service Limit: 31.5 mm (1.24 in.)

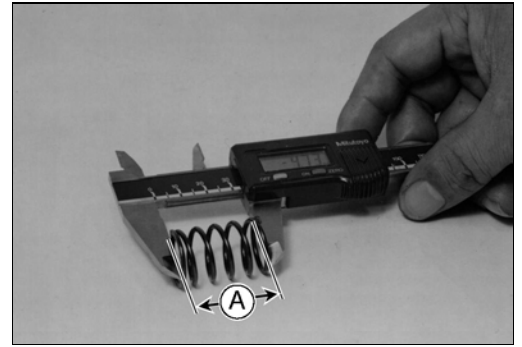

5-12 ENGINE TOP END

Cylinder, Piston

Piston Removal

- Split the crankcase (see Camshaft/Crankshaft chapter).
- Remove the camshaft (see Camshaft/Crankshaft chapter).
- Turn the crankshaft to expose the connecting rod cap bolts [A].
- Remove the bolts and take off the connecting rod caps [B].

NOTE

- Note the position of the connecting rod caps for reinstalling the caps.

- Push the connecting rod end into the cylinder, and pull the piston and connecting rod out of the cylinder.

CAUTION

Note the location of the arrow match mark [A] on the piston head in relation to K Mark [B] on the connecting rod.
No.1 cyl. K Mark on the connecting rod is face to face with No.2 cyl. K Mark on the connecting rod.
Keep parts together as a set.

- Remove one of the piston pin snap rings [A] with needle nose pliers [B].

- Remove the piston by pushing the piston pin [A] out the side from which the snap ring was removed.

- Remove the top and second rings with piston ring pliers.

Special Tool - Piston Ring Pliers: 57001-115

- If the special tool is not available, carefully spread the ring opening with your thumbs and then push up on the opposite side of the ring [A] to remove it.
- Remove the 3-piece oil ring with your thumbs in the same manner.

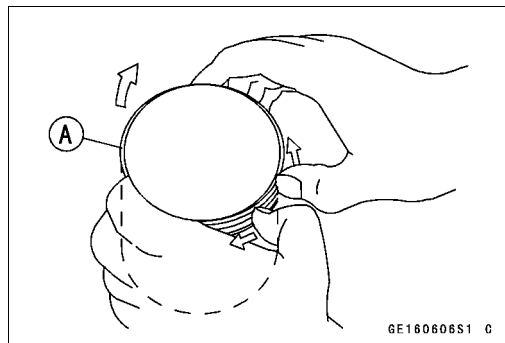
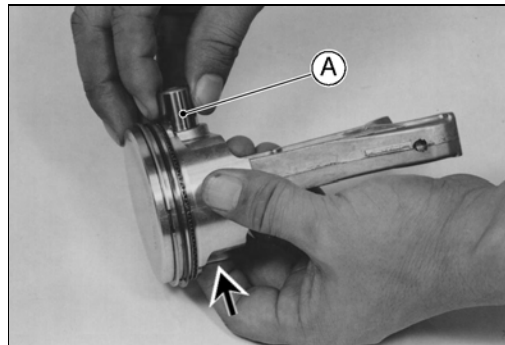
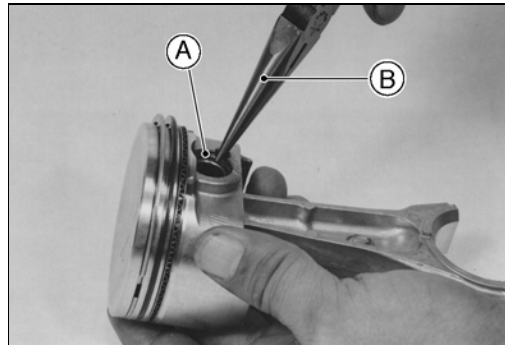
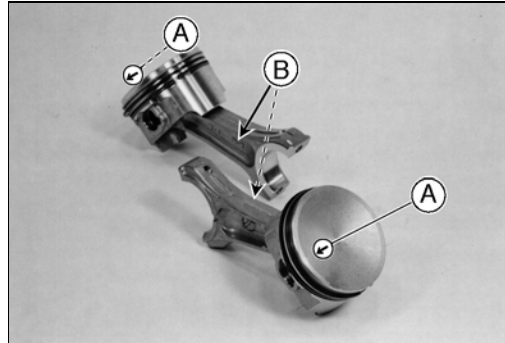
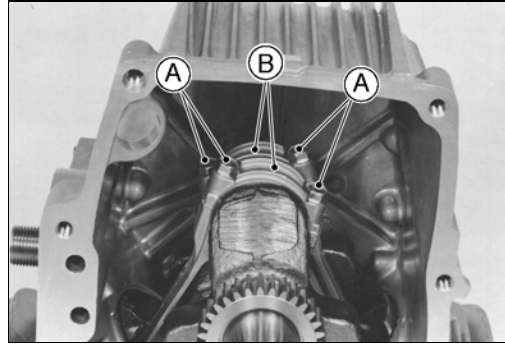

Cylinder, Piston

Piston Installation

- Install the expander [A] in the piston oil ring groove so that the expander ends [B] touch together, never overlap.
- Install the upper and lower steel rails. There is no UP or Down to the rails. They can be installed either way.

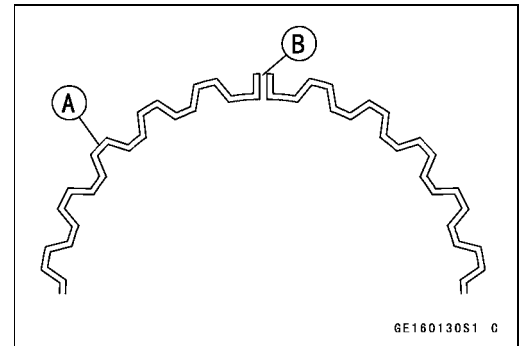

- Do not mix up the top and second rings.
- Install the second ring so that the "0" mark faces up.
- Install the top ring.
- The rings should turn freely in the grooves.
 - [A] Piston Head
 - [B] Top Ring
 - [C] Second Ring

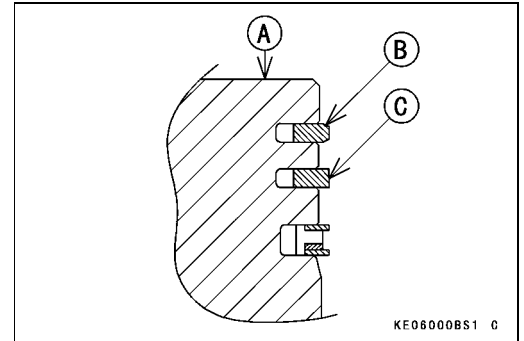

- Align the piston and rings with the piston ring end gap as shown.
 - [A]. Arrow Match Marks
 - [B]. Top ring End Gap, Upper Steel Rail End Gap
 - [C]. 30° ~ 45°
 - [D]. Second Ring End Gap, Lower Steel Rail End Gap

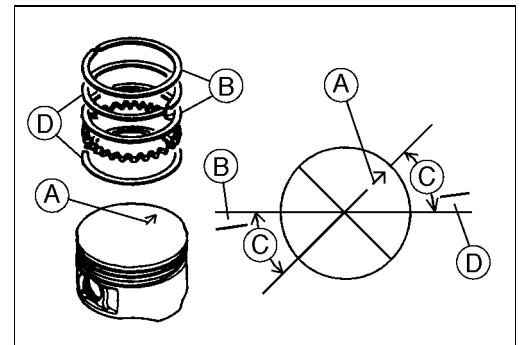

- Apply engine oil to the piston pins.
 - Assemble the pistons onto the connecting rods as follow:
 - No.1 cyl. Piston, align the arrow mark on the piston head with the raised letters (K Mark) on the connecting rod.
 - No.2 cyl. piston, align the arrow mark on the piston head opposite K Mark on the connecting rod.
 - [A]. No.1 Cyl. Piston
 - [B]. No.2 Cyl. Piston
 - [C]. Arrow Marks
 - [D]. K Mark
 - [E]. Opposite K Mark

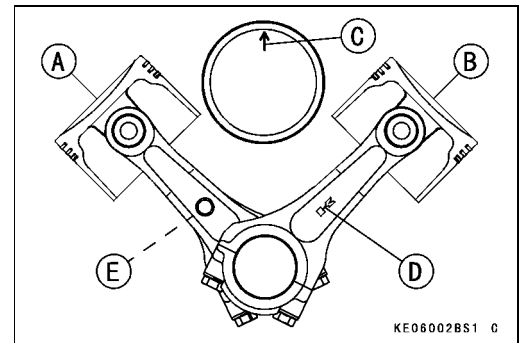

- When installing a piston pin snap ring, compress it only enough to install it and no more.
 - Fit a new piston pin snap ring into the side of the piston so that the ring opening [A] does not coincide with the notch [B] in the edge of the piston pin hole.

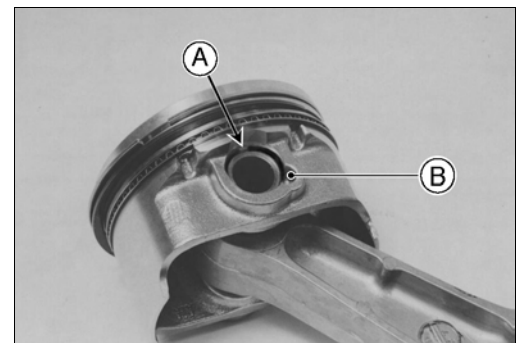

CAUTION

Do not reuse the snap rings, as removal weakens and deforms them. They could fall out and score the cylinder wall.

5-14 ENGINE TOP END

Cylinder, Piston

- Apply engine oil to the piston skirt and the cylinder bore.
- ★ Using the piston ring compressor grip [A] and the belt [B], lightly tap the top of the piston with a plastic mallet [C] to insert the piston and connecting rod into the cylinder.

**Special Tools - Piston Ring Compressor Grip: 57001-1095
Piston Ring Compressor Belt: 57001-1096**

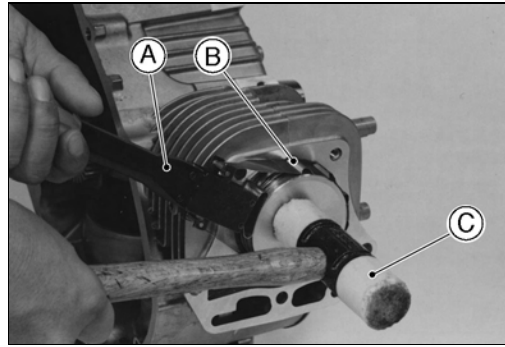

- Insert the piston and connecting rod so that the arrow mark [A] on the top of the piston is facing the flywheel side [B].

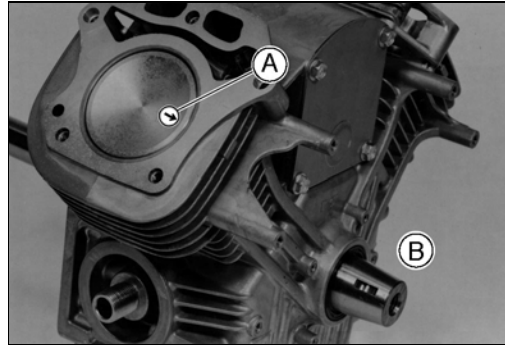

CAUTION

The connecting rod and the connecting rod big end cap are machined at the factory in the assembled state, so they must be replaced together as a set.

- Apply engine oil to the inner surface [A] of the connecting rod big end [B] and caps [C].
- Install the connecting rod big end caps in their original position on each connecting rod big ends.
- Apply a small amount of engine oil to the thread [D] and seating surface [E] of the cap bolts.
- Tighten the cap bolts.

Torque - Connecting Rod Big End Cap Bolts: 5.9 N·m (0.60 kgf·m, 52 in·lb)

- Install:
 - Camshaft (see Camshaft/Crankshaft chapter)
 - Crankcase Cover (see Camshaft/Crankshaft chapter)

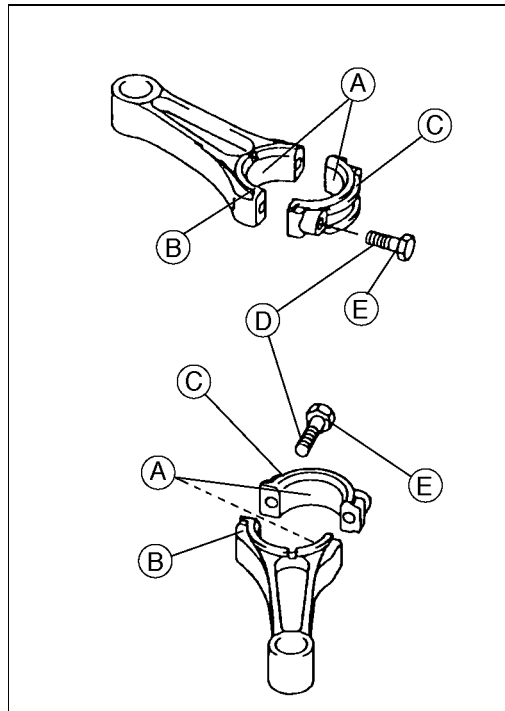

Piston/Cylinder Seizure

- In case of seizure, remove the piston.
- Visually inspect the cylinder and piston damage.
- ★ If there is only light damage, smooth the position with #400 emery cloth. Remove the small aluminum deposits from the cylinder with #400 emery cloth or light honing.
- ★ If the damage is severe, both cylinders must be bored oversize and oversized pistons installed.

Cylinder, Piston

Piston Cleaning

- Remove the piston and piston rings (see Piston Removal).

CAUTION
Never clean the piston head with the engine assembled. Carbon particles will fall between the piston and cylinder, and damage the crankshaft bearings.

- Scrape the carbon off [A] the piston head.
- Use the scraping tools carefully. Do not gouge the piston head. To avoid gouging, use scrapers that are made of a material that will not cause damage.
- Clean the piston ring grooves [A] with a broken piston ring or other suitable tools.

CAUTION
Be careful not to widen the ring grooves. Damaged ring grooves will require piston replacement.

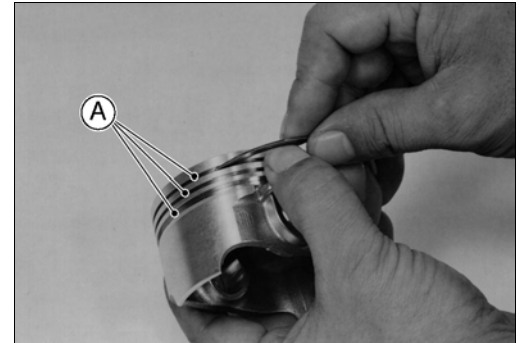

Piston Ring and Ring Groove Wear

- Clean the piston (see Piston Cleaning).
- Visually inspect the piston rings and ring grooves.
- ★ If the piston rings are worn unevenly or damaged, replace them.
- ★ If the ring grooves are worn unevenly or damaged, replace both the piston and piston rings.
- Check ring grooves for wear by inserting a new ring in the proper groove at several points around the piston.
- Measure the clearance between the top and second rings and their grooves using a thickness gauge [A].
- ★ If the piston ring/groove clearance is greater than the specified value, replace the piston.

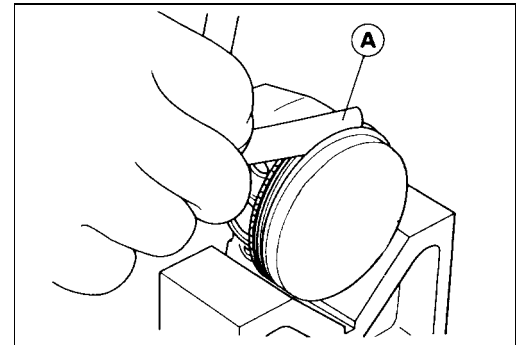

Piston Ring/Groove Clearance
Service Limit

Top	0.18 mm (0.007 in.)
Second	0.18 mm (0.007 in.)

NOTE

- *The oil ring is a three piece assembled ring. It is difficult to measure the ring groove clearance and thickness, visually inspect only.*
- Measure the piston ring thickness [A].
- Use a micrometer to measure at several points around the rings.
- ★ If any of the measurement are less than the service limit, replace the entire set of rings.

Piston Ring Thickness

	Service Limit
Top, Second	1.40 mm (0.055 in.)

NOTE

- *When using new rings in a used piston, check for uneven groove wear. The rings should fit perfectly parallel to the groove sides. If not, replace the piston.*

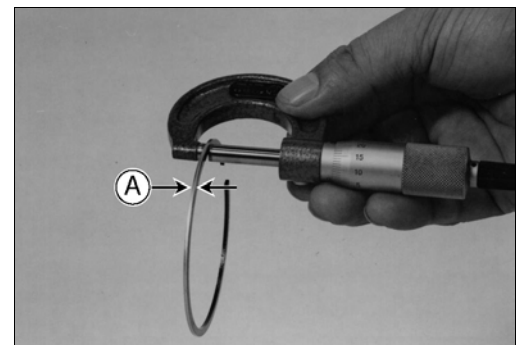

5-16 ENGINE TOP END

Cylinder, Piston

Piston Ring End Gap

- Remove the piston rings.
 - Push each ring (one at a time) in the cylinder bore to a point close to the bottom of the cylinder bore.
 - Use the piston to push it in to be sure it is square.
 - Measure the gap [A] between the ends of the ring [B] with a thickness gauge.
- ★ If the end gap of any ring is greater than the service limit, replace the entire set of rings.

Piston Ring End Gap

	Service Limit
Top	0.75 mm (0.029 in.)
Second	0.75 mm (0.029 in.)
Oil	1.05 mm (0.041 in.)

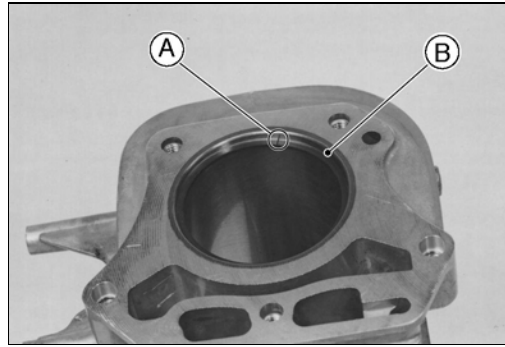

Piston Pin, Piston Pin Hole, and Connecting Rod Wear

- Remove the piston pin.
 - Measure the diameter of the piston pin with a micrometer at several points.
- ★ If the outside diameter is less than service limit, replace the piston pin.

Piston Pin Outside Diameter

Service Limit:	15.96 mm (0.628 in.)
----------------	----------------------



- Measure the inside diameter [A] of the piston pin hole at several points on both side. Use a dial bore gauge.
- ★ If the inside diameter is more than the service limit, replace the piston.

Piston Pin Hole Inside Diameter

Service Limit:	16.08 mm (0.633 in.)
----------------	----------------------

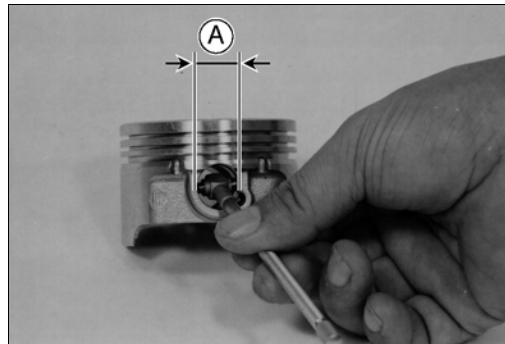

- Measure the inside diameter [A] of the small end of the connecting rod at several points. Use a dial bore gauge.
- ★ If the inside diameter is more than the service limit, replace the connecting rod.

Connecting Rod Small End Inside Diameter

Service Limit:	16.05 mm (0.632 in.)
----------------	----------------------

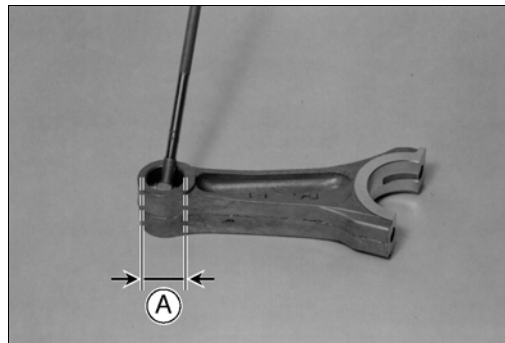

Cylinder, Piston

Piston Diameter

- Measure the outside diameter [A] of the piston 12.5 mm (0.9 in.) up [B] from the bottom of the piston at a right angle to the direction of the piston pin hole.
- ★ If the measurement is less than the service limit, replace the piston.

Piston Diameter
Service Limit: 64.79 mm (2.551 in.)

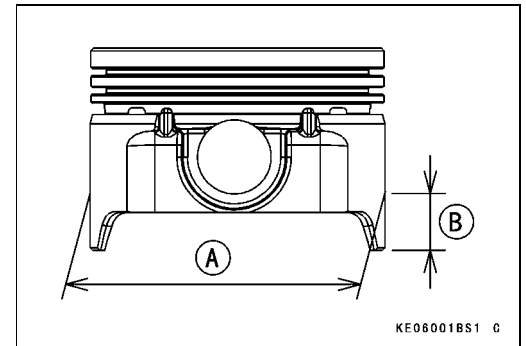

Cylinder Inside Diameter

- Clean and measure the cylinder inside diameter.
- Use a dial bore gauge to measure front-to-back and side-to-side at the points shown figure.
- ★ If any of the cylinder bore measurements is greater than the service limit, the cylinder must be bored to the next oversize and then honed (see Cylinder Boring and Honing).

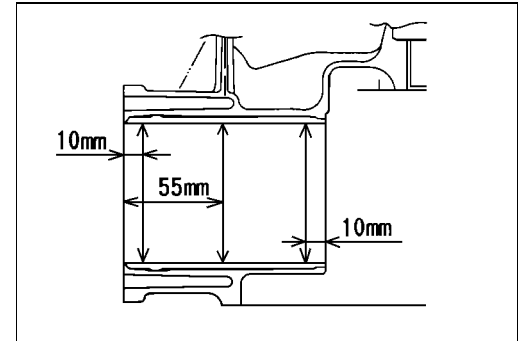

Cylinder Inside Diameter

Item	standard	Service Limit
Standard Cylinder	64.98 ~ 65.00 mm (2.558 ~ 2.559 in.)	65.10 mm (2.563 in.)
0.5 mm Oversize Cylinder	65.48 ~ 65.50 mm (2.578 ~ 2.579 in.)	65.60 mm (2.583 in.)

Cylinder Bore Out-of-Round

Standard: 0.01 mm (0.004 in.)
Service Limit: 0.056 mm (0.0022 in.)

Cylinder Boring and Honing

Always resize to exactly 0.5 mm (0.02 in.) over the standard bore size.

If this is done accurately, the stock oversize rings and piston will fit perfectly and proper clearance will be maintained.

Resizing the cylinder bore can be done by reliable repair shop or by using a drill press and honing tool.

Use the stone recommended by the hone manufacturer to produce correct cylinder wall finish.

Machine-bore first, the bore diameters should be shown in the table.

Final Boring Bore Diameter

Oversize	Final Boring Bore Diameter
0.50 mm	65.46 ~ 65.48 mm (2.577 ~ 2.578 in.)

Final Bore Diameter

Oversize	Final Bore Diameter
0.50 mm	65.48 ~ 65.50 mm (2.578 ~ 2.579 in.)

5-18 ENGINE TOP END

Cylinder, Piston

Change to a honing stone for finishing, the final bore diameter should be as shown in the table.

Be sure the correct stone is used and the stone is not worn.

- Clean the cylinder at the top and bottom of the cylinder to remove burns and pieces of the base and head gasket.
- Anchor the cylinder (block) on the drill press table before honing.
- Align the center of the cylinder bore to the press center. Set the press to operate from 200 to 250 rpm.
- Connect the drive shaft to the hone and set the stop on the drill press so the hone can only extend 20 to 25 mm (3/4 to 1.0 in.) above the top or below the bottom of the cylinder liner.
- Rotate the adjusting nut (knob) on the hone until the stones contact snugly against the cylinder wall at the narrowest point. "Do not Force".
- Turn the stone by hand. If you cannot turn it, the stone is too tight. Loosen the hone until it can be turned by hand.
- Be sure that the cylinder and hone are centered and aligned with the drive shaft and drill spindle.
- Pour honing oil inside of the cylinder during the honing operation. Start the drill press. Move the hone up and down in the cylinder approximately 20 cycles-per-minute.
- Check the diameter of the cylinder bore regularly during honing, using an inside micrometer.

CAUTION

Stop the drill press before measuring and remove the hone from the cylinder.

NOTE

- *The finish should not be smooth, but have a 40 to 60 degree crosshatch pattern.*
- Hone the cylinder until it is about 0.007 to 0.009 mm (0.0003 to 0.0004 in) large to allow for shrinkage when the cylinder cools.

NOTE

- *Do not use gasoline, kerosene, or commercial solvent to clean the cylinder bore. These fluids only wash all the oil from the cylinder wall. They do not remove the metal particles produced during honing.*
- Using soap, warm water and clean rags, clean the cylinder wall. A clean white rag should not show soil from the cylinder wall.
- Dry the cylinder and coat with an engine oil.

CAUTION

The cylinder must be thoroughly cleaned after honing to eliminate all grit.

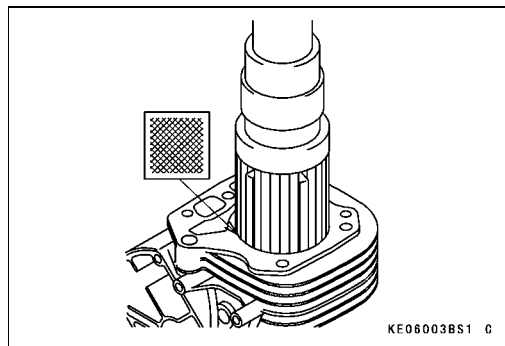

Muffler/Exhaust Pipe Installation

Muffler/Exhaust Pipe Removal

- Loosen the clamp nut [A].
- Remove the bolt [B] on the muffler bracket and take off the muffler.

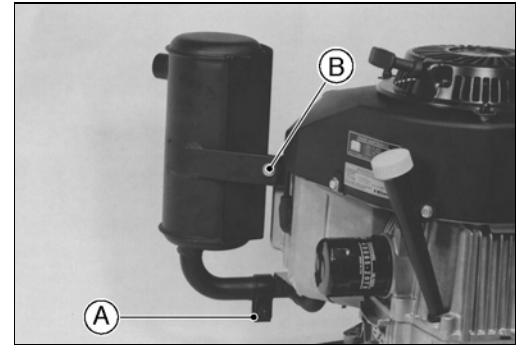

- Unscrew the exhaust pipe flange nuts [A], and remove the exhaust pipe [B] with pipe cover [C]. Use a penetrating oil if necessary to break threads loose.
- Remove the gaskets.
- Unscrew the hook nut [D], separate the exhaust pipe and pipe cover.
- Do not use unnecessary force on the exhaust pipes when removing the muffler assembly, or they could become damaged or distorted.

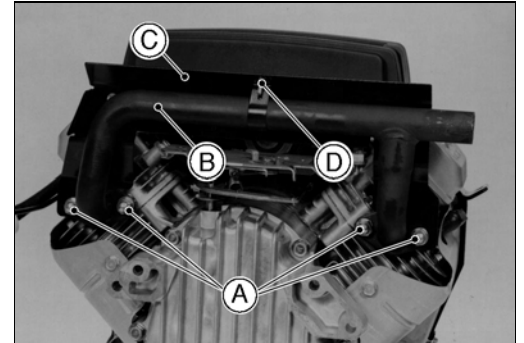

Muffler/Exhaust Pipe Installation

- Clean the exhaust pipe flanges and the exhaust port gasket surfaces and install a new gaskets each time the muffler installed.
- Install the gasket.
- To prevent mis-threading, finger tight the flange nuts first. Next tighten the hook nut.
- Tighten the nuts.

Torque - Exhaust Pipe Flange Nuts: 15 N·m (1.5 kgf·m, 11 ft·lb)

- Install the muffler.
- After installation, thoroughly warm up the engine, wait until the engine cools down and retighten the bolts and nuts.

Inspection

- Inspect the exhaust pipe or muffler for dents, cracks, rust and holes.
- ★ If the exhaust pipe or muffler is damaged, it should be replaced for best performance and least noise.
- Check the muffler for distortion and/or loose internal components. Loss of power could develop if loose internal muffler components restrict exhaust flow.
- Check for breaks in the seams and check weld at the junction of the exhaust pipes and muffler.
- Tap the muffler with a plastic hammer to decarbonize.

Lubrication System

Table of Contents

Exploded View.....	6-2
Engine Oil Flow Chart.....	6-3
Specifications.....	6-4
Engine Oil and Oil Filter.....	6-5
Oil Level Inspection.....	6-5
Oil Change.....	6-5
Oil Filter Change.....	6-5
Pressurized Lubrication System.....	6-6
Oil Pressure Measurement.....	6-6
Oil Pump, Relief Valve.....	6-7
Oil Pump, Relief Valve Removal.....	6-7
Oil Pump, Relief Valve Installation.....	6-7
Oil Pump, Relief Valve Inspection.....	6-7
Oil Screen.....	6-9
Oil Screen Removal.....	6-9
Oil Screen Installation.....	6-9
Cleaning and Inspection.....	6-9

6-2 LUBRICATION SYSTEM

Exploded View

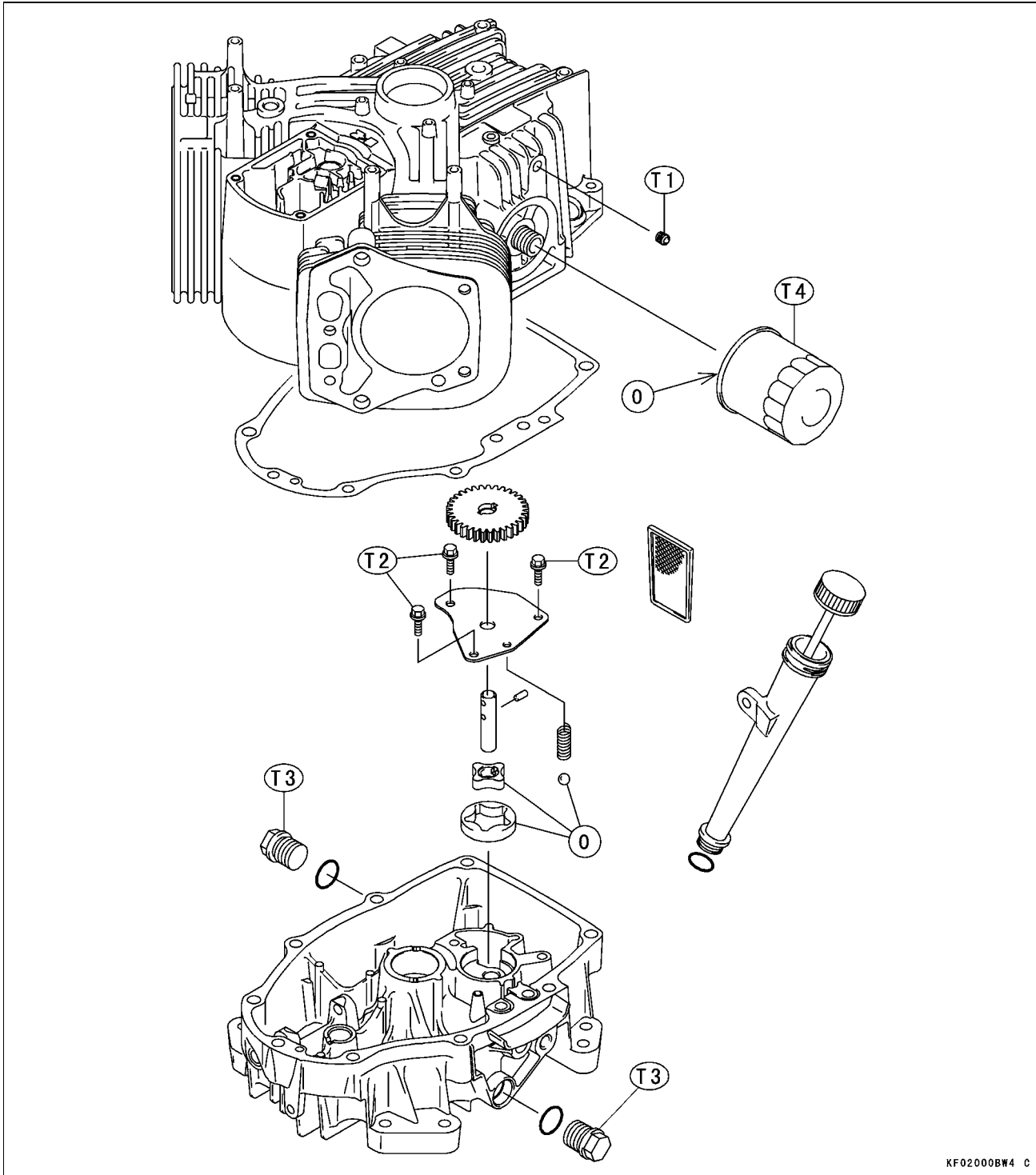

- T1: 3.9 N·m (0.40 kgf·m, 35 in·lb)
T2: 5.9 N·m (0.60 kgf·m, 52 in·lb)
T3: 6.9 N·m (0.70 kgf·m, 61 in·lb)
T4: See the text

O: Apply engine oil.

Specifications

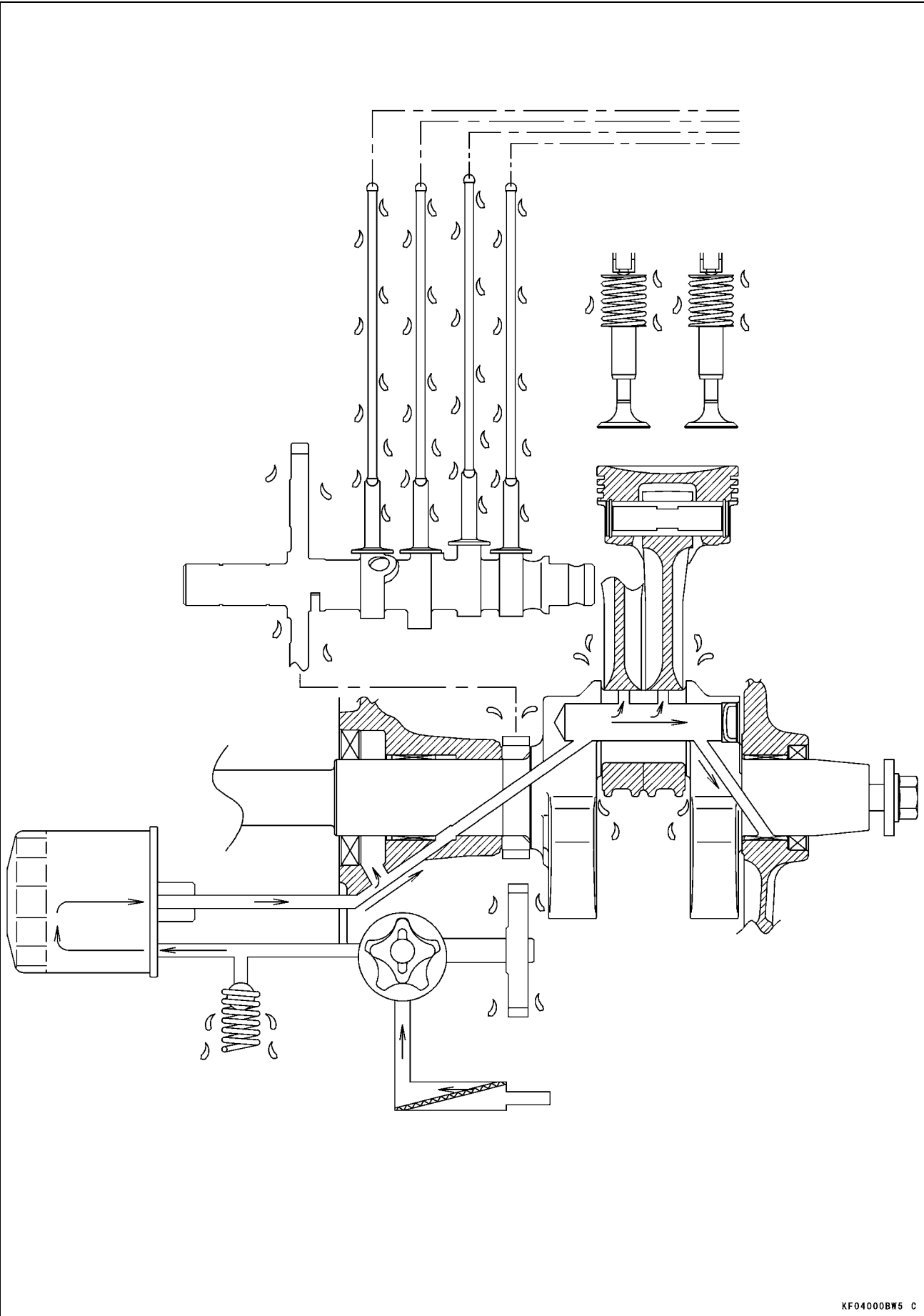

6-4 LUBRICATION SYSTEM

Specifications

Item	Standard
Engine Oil:	
Type	SF, SG, SH or SJ class
Viscosity	SAE40, SAE30, SAE10W-30/SAE10W-40, or SAE5W-20
Capacity	[When filter is not removed] 1.5 L (1.6 US qt) [When filter is removed] 1.7 L (1.8 US qt)
Level	Operating range (grid area) on dipstick
Oil Pressure	241 to 310 kPa (35 to 45 psi)/3000 rpm
Oil Filter By-pass Valve Opening Pressure	78.5 ~ 117.5 kPa (11.4 ~ 17.1 psi)

Item	Service Limit
Oil Pump:	
Inner and outer rotor clearance	0.2 mm (0.008 in.)
Outer rotor outside diameter	40.470 mm (1.5933 in.)
Outer rotor thickness	9.830 mm (0.3870 in.)
Pump housing inside diameter	40.801 mm (1.6063 in.)
Pump housing depth	10.230 mm (0.4028 in.)
Pump shaft outside diameter	10.923 mm (0.4300 in.)
Pump shaft bearing inside diameter	11.072 mm (0.4359 in.)
Relief valve spring free length	19.50 mm (0.77 in.)

Special Tool - Oil Filter Wrench : 57001-1249

Engine Oil and Oil Filter

CAUTION

Engine operation with insufficient, deteriorated, or contaminated engine oil will cause accelerated wear and may result in engine seizure and accident.

Before starting the engine for the first time, add oil: The engine is shipped dry. Preoil the engine to force all air from the internal oil passages and the oil filter.

- Fill fresh engine oil to the specified level (see Periodic Maintenance chapter).
- Run the engine at slow speed 2 minutes.
- Stop the engine and check the oil level.

Oil Level Inspection

- Refer to Oil Level Inspection in the Periodic Maintenance Chapter (2nd chapter).

Oil Change

- Refer to Oil Change in the Periodic Maintenance Chapter (2nd chapter).

Oil Filter Change

- Refer to Oil Filter Change in the Periodic Maintenance Chapter (2nd chapter).

6-6 LUBRICATION SYSTEM

Pressurized Lubrication System

The engine lubrication circuit is a pressurized system consisting of a positive displacement pump which picks up oil through a filter screen from the crankcase. The oil is pumped to a replaceable oil filter cartridge, through the engine's oil passages to lubricate internal components, and return to the crankcase. A pressure relief valve is used between the oil pump and oil filter to relieve excessive oil pressure by returning excess oil to the crankcase (see Oil Flow Chart).

Oil Pressure Measurement

- Remove the oil passage plug from the crankcase.
- Install the oil pressure gauge adapter [A] and oil pressure gauge [B].
- Run the engine and allow warm up completely.
- Run the engine at fast idle speed and read the oil pressure gauge.
- Stop the engine.
- Remove the oil pressure gauge and adapter.
- Tighten the oil passage plug.

Special Tools - Oil Pressure Gauge, 5 kgf/cm²: 57001-125

Oil Pressure Gauge Adapter, PT 1/8: 57001-1033

Torque - Oil Passage Plug : 3.9 N·m (0.40 kg·m, 35 in·lb)

- ★ If the oil pressure is below the specification, inspect the oil pump and relief valve.
- ★ If the oil pump and relief valve are not at fault, inspect the rest of the lubrication system.

Oil Pressure

241 to 310 kPa (35 to 45 psi)/3000 rpm

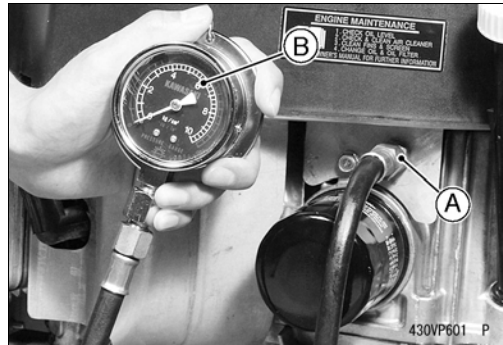

Oil Pump, Relief Valve

Oil Pump, Relief Valve Removal

- Remove the crankcase cover (see Camshaft/Crankshaft chapter).
- Unscrew the mounting bolts and remove the oil pump parts assembly (pump gear, pump cover plate, pump shaft, pins and rotors).
- Take off the relief valve spring and ball.
- Disassemble the pump parts assembly.
 - [A] Pins
 - [B] Pump Gear
 - [C] Mounting Bolts
 - [D] Outer Rotor
 - [E] Inner Rotor
 - [F] Pump Shaft
 - [G] Relief Valve Ball
 - [H] Spring
 - [I] Pump Cover Plate
 - [J] 6 mm dia Hole

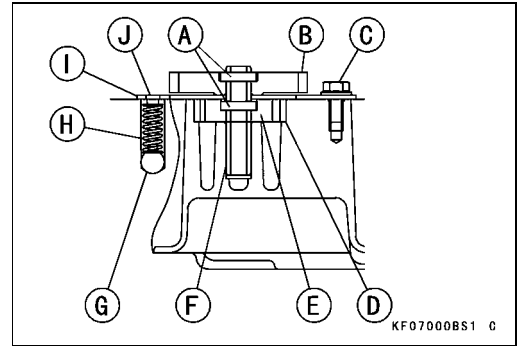

Oil Pump, Relief Valve Installation

- Fill the rotor housing with engine oil for initial lubrication.
- Install the relief valve ball and spring in position, then install the pump parts assembly in the crankcase cover.

NOTE

- When installing the pump parts assembly, align the 6 mm dia hole [A] on the cover plate with center of the relief valve.
- Install the mounting bolts and tighten them.

Torque - Oil Pump Cover Plate Mounting Bolts : 5.9 N·m (0.60 kgf·m, 52 in·lb)

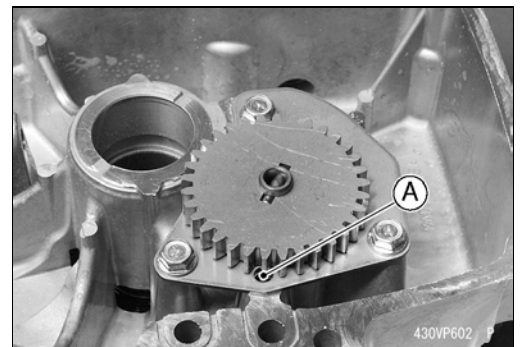

Oil Pump, Relief Valve Inspection

- Remove the oil pump (see Oil Pump, Relief Valve Removal).
- Visually inspect the pump gear, outer and inner rotor, and cover plate.
- ★ If there is any damage or uneven wear, replace them.
- Check the clearance [A] between the inner and outer rotor with a feeler gauge. Measure the clearance between the high point of the inner rotor and the high point of the outer rotor.
- ★ If the measurement exceed the service limit, replace the rotors as a set.

Inner and Outer Rotor Clearance

Service Limit: 0.2 mm(0.008 in.)

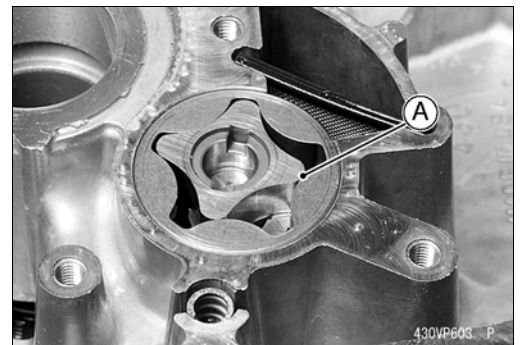

- Measure the outside diameter [A] of the outer rotor with a micrometer at several points.
- ★ If the rotor diameter is less than the service limit, replace both the inner and outer rotor.

Outer Rotor Outside Diameter

Service Limit: 40.470 mm(1.5933 in.)

- Measure the thickness [B] of the outer rotor with a micrometer at several points
- ★ If the rotor thickness is less than the service limit, replace both the inner and outer rotor.

Outer Rotor Thickness

Service Limit: 9.830 mm (0.3870 in.)

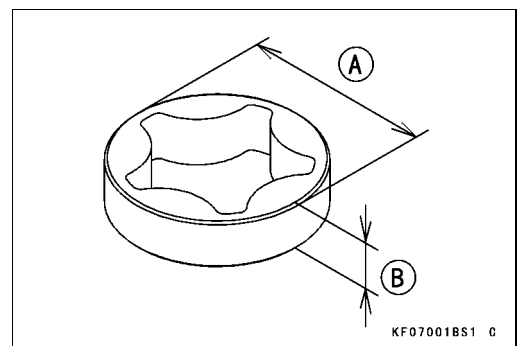

6-8 LUBRICATION SYSTEM

Oil Pump, Relief Valve

- Measure the inside diameter [A] of the pump housing with an inside micrometer at several points.
- ★ If the inside diameter is more than the service limit, replace the crankcase cover.

Pump Housing Inside Diameter

Service Limit: 40.801 mm (1.6063 in.)

- Measure the depth [B] of the pump housing with a depth micrometer at several points.
- ★ If any of measurement is more than the service limit, replace the crankcase cover.

Pump Housing Depth

Service Limit: 10.230 mm (0.4028 in.)

- Measure the outside [A] diameter of the pump shaft with a micrometer at several points.
- ★ If the diameter is less than the service limit, replace the pump shaft.

Pump Shaft Outside Diameter

Service Limit: 10.923 mm (0.4300 in.)

- Measure the inside diameter [A] of the pump shaft bearing in the crankcase cover with an inside micrometer at several points.
- ★ If the inside diameter is more than the service limit replace the crankcase cover.

Pump Shaft Bearing Inside Diameter

Service Limit: 11.072 mm (0.4359 in.)

- Visually inspect the relief valve spring, steel ball and valve seat in the crankcase cover.
- ★ If any rough spots are found during above inspection, wash the valve clean with a high flash-point solvent and blow out any foreign particles that may be in the valve with compressed air.

⚠ WARNING

Clean the parts in a well ventilated area, and take care that there is no spark or flame anywhere near the working areas. Because of the danger of highly flammable liquids, do not use gasoline or low flash-point solvents.

- ★ If cleaning does not solve the problem, replace the relief valve parts.
- ★ If necessary, put the ball in position and lightly tap the ball with a suitable tools to form a perfect seat.
- Measure free length [A] of the spring with a vernier caliper.
- ★ If the free length of the spring is less than the service limit, replace the spring.

Relief Valve Spring Free Length

Service Limit: 19.50 mm (0.77 in.)

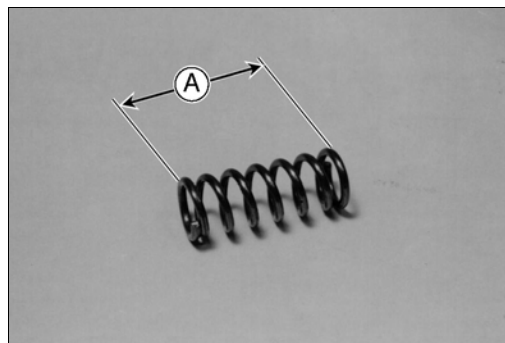
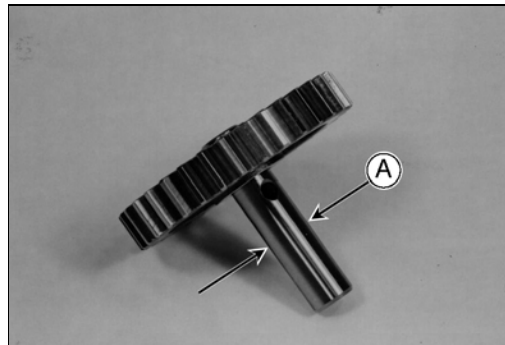
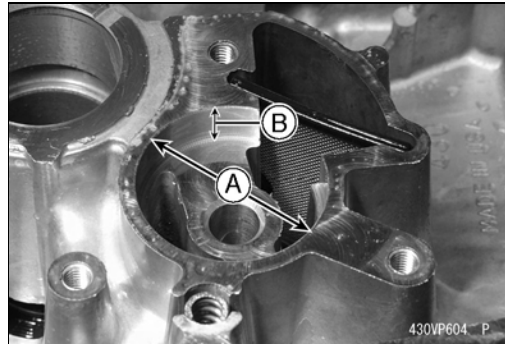

Oil Screen

Oil Screen Removal

- Remove the crankcase cover (see Camshaft/Crankcase chapter).
- Unscrew the mounting bolts [A] and remove the oil pump parts assembly.

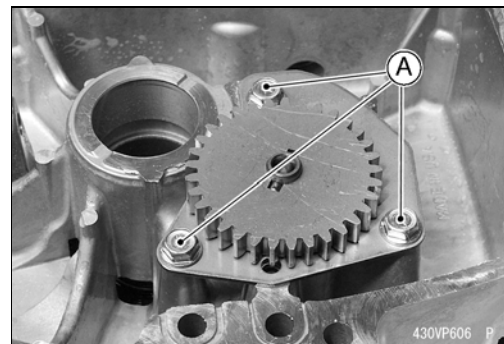

- Remove the oil screen [B]

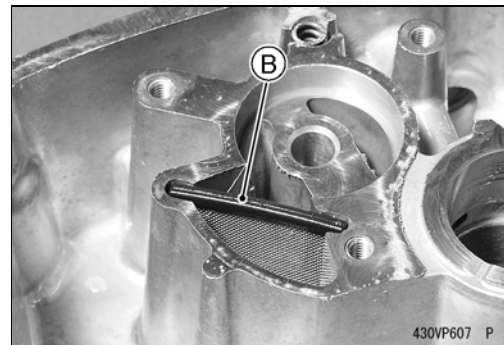

Oil Screen Installation

- Clean the oil screen thoroughly whenever it is removed for any reason.
- Insert the oil screen [A] in position and install the oil pump parts assembly (see Oil Pump, Relief Valve Installation).

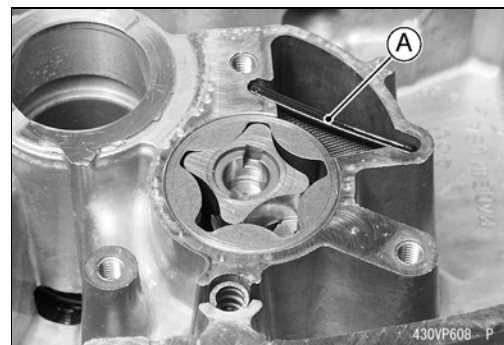

Cleaning and Inspection

- Clean the oil screen with high flash-point solvent and remove any particles stuck to it.

⚠ WARNING

Clean the screen in a well-ventilated area, and take care that there is no spark or flame anywhere near the working area. Because of the danger of highly flammable liquids, do not use gasoline or low flash-point solvents.

NOTE

- While cleaning the screen, check for any metal particles that might indicate internal engine damage.
- Check the screen carefully for any damage: holes and broken wire.
- ★ If the screen is damaged, replace it.

Camshaft/Crankshaft

Table of Contents

Exploded View.....	7-2
Specifications.....	7-3
Crankcase.....	7-4
Crankcase Cover Removal.....	7-4
Crankcase Cover Installation.....	7-4
Inspection.....	7-5
Cleaning.....	7-5
Breather.....	7-6
Breather Chamber Cover Removal.....	7-7
Breather Chamber Cover Installation.....	7-7
Camshaft, Tappet.....	7-8
Camshaft, Tappet Removal.....	7-8
Camshaft, Tappet Installation.....	7-8
Camshaft Disassembly.....	7-9
Camshaft Assembly.....	7-9
Camshaft Inspection.....	7-9
Camshaft Bearing/Journal Wear.....	7-9
Crankshaft, Connecting Rod.....	7-11
Connecting Rod Removal.....	7-11
Connecting Rod Installation.....	7-11
Crankshaft Removal.....	7-11
Crankshaft Installation.....	7-11
Cleaning/Inspection.....	7-11
Connecting Rod Bend/Twist.....	7-11
Connecting Rod Big End/Crankpin Width Wear.....	7-12
Connecting Rod Big End Bearing/Crankpin Wear.....	7-12
Crankshaft Runout.....	7-13
Crankshaft Main Journal/Wear.....	7-13
Crankpin Resizing.....	7-13

7-2 CAMSHAFT/CRANKSHAFT

Exploded View

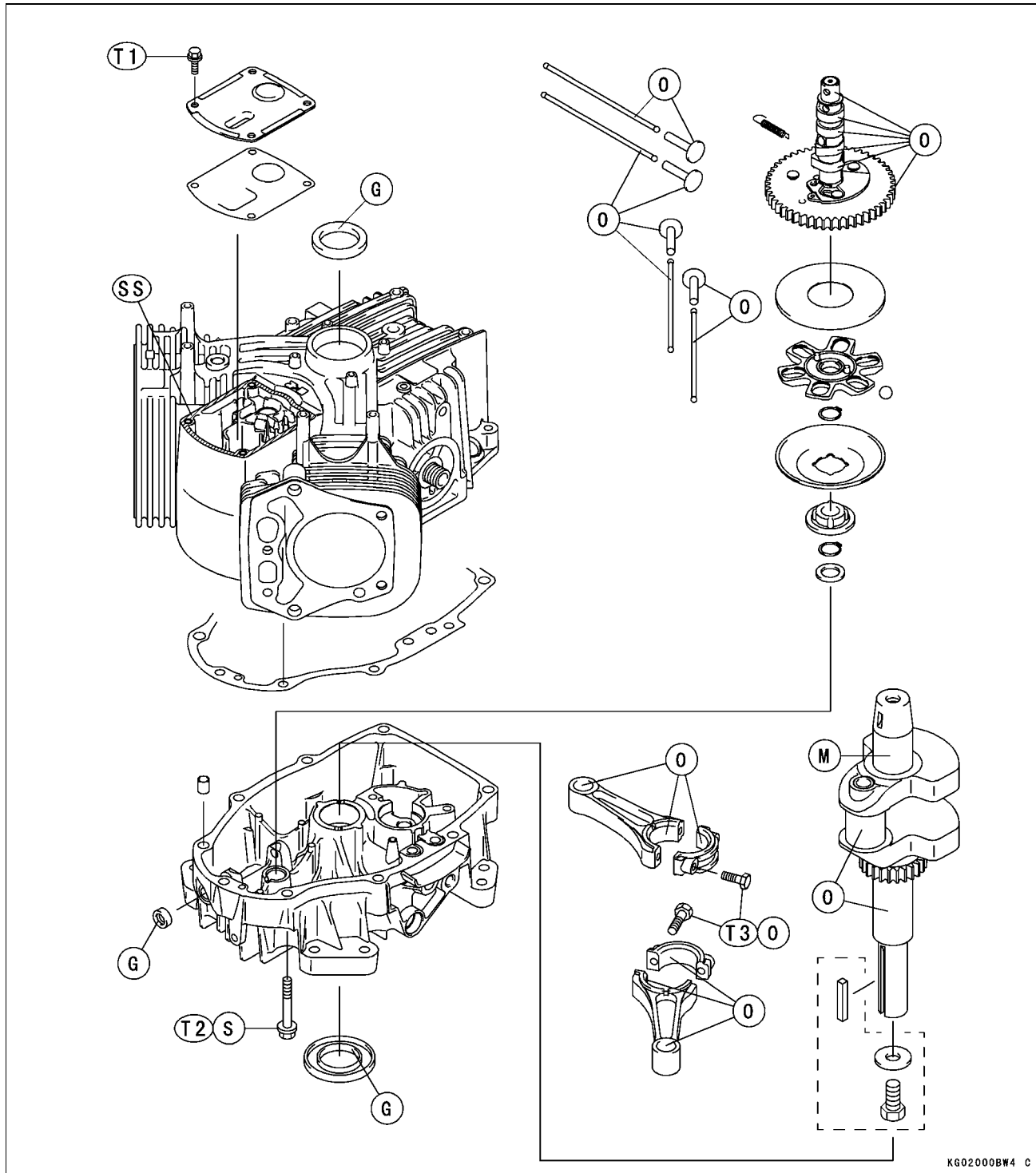

T1: 5.9 N·m (0.60 kgf·m, 52 in·lb)
T2: 25 N·m (2.6 kgf·m, 19 ft·lb)
T3: See Engine Top End chapter.

O: Apply engine oil.
G: Apply grease.
M: Apply molybdenum disulfide grease.
SS: Apply silicone sealant.
S: Follow the specific tightening sequence.

CAMSHAFT/CRANKSHAFT 7-3

Specifications

Item	Service Limit
Camshaft, Tappet:	
Cam lobe height	Intake 29.131 mm (1.1469 in.) Exhaust 29.131 mm (1.1469 in.)
Camshaft journal diameter	PTO side 15.985 mm (0.6293 in.) Flywheel side 15.985 mm (0.6293 in.)
Camshaft bearing inside diameter	Crankcase 16.136 mm (0.6352 in.) Crankcase cover 16.136 mm (0.6352 in.)
Crankshaft, Connecting Rod:	
Connecting rod bend	0.15/100 mm (0.006/3.94 in.)
Connecting rod twist	0.15/100 mm (0.006/3.94 in.)
Connecting rod big end width	18.80 mm (0.74 in.)
Crankpin width	39.50 mm (1.56 in.)
Connecting rod big end inside diameter	33.055 mm (1.301 in.)
Crankpin Outside diameter	32.94 mm (1.297 in.)
Crankshaft runout	0.05 mm (0.002 in.) TIR
Crankshaft journal diameter	PTO side 34.90 mm (1.374 in.) Flywheel side 34.94 mm (1.376 in.)
Crankcase:	
PTO shaft bearing inside diameter	
Crankcase Cover	35.15 mm (1.384 in.)
Crankshaft journal bearing inside diameter	
Crankcase	35.15 mm (1.384 in.)

Sealant - Bond (Silicone Sealant): 56019-120

7-4 CAMSHAFT/CRANKSHAFT

Crankcase

Crankcase Cover Removal

- Set the engine on a clean surface while parts are being removed.
- Drain the oil (see Lubrication System chapter).
- Remove:
 - Exhaust Pipe and Muffler (see Engine Top End chapter)
 - Control Panel (see Fuel System chapter)
 - Governor Arm (see Fuel System chapter)
- When inverting the engine is necessary to remove the crankcase cover, be sure to remove the air cleaner cover and air filter elements. Gasoline may drain from the carburetor and soak into the filter elements if the air cleaner case is not removed.

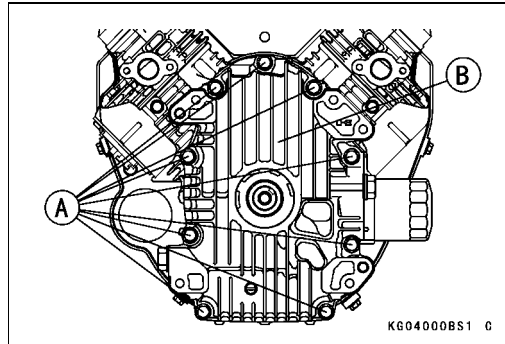

CAUTION

If the carburetor bowl has gasoline in it, the gasoline may spill out if the engine is turned upside-down. Use caution when inverting the engine.

- Unscrew the mounting bolts [A] and remove the crankcase cover [B] from the crankcase.
- There are two knock pins on the crankcase mating surface. A wooden or plastic mallet may be used to gently tap loose the crankcase cover.

Crankcase Cover Installation

- Chip off the old gasket from the mating surfaces of the crankcase and cover.
- Using compressed air, blow out the oil passage in the crankcase cover.
- With a high flash-point solvent, clean off the mating surfaces of the crankcase and cover, and wipe dry.

WARNING

Clean the crankcase and cover in a well-ventilated area, and take care that there are no sparks or flame anywhere near the working area; this includes any appliance with a pilot light. Do not use gasoline or a low flash-point solvent to clean parts. A fire or explosion could result.

- Be sure to replace any oil seal removed with a new one.
 - Install the oil seal so that the marks [A] face out.
 - Thoroughly pack high temperature grease [B] into the space between the seal lip [C] and dust lip [D]. Press in the new oil seal using a press or suitable tools until it is flush with flange surface [E]. Do not damage the seal lips.
-
- When replacing the oil seal [A] of the governor shaft, note the following.
 - Install the oil seal into the crankcase cover [B] after the governor shaft is inserted in the cover, and so that the marks [C] face out.
 - The depth is 0~1 mm (0~0.04 in.) [D].
 - When installing the governor shaft and plate in the crankcase cover, see Fuel System chapter.

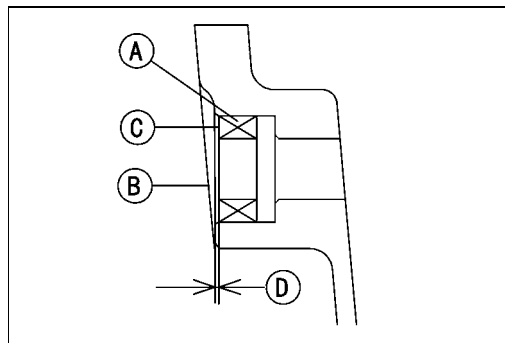
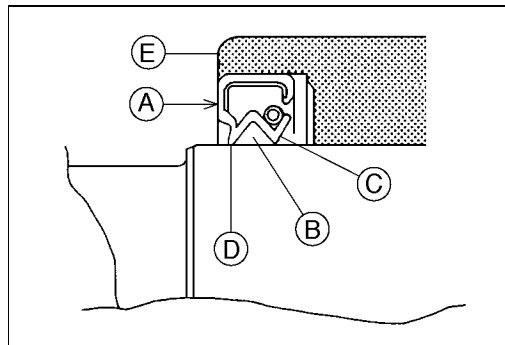

Crankcase

- Check to see that the crankcase dowel pins [A] are in place on the crankcase.
- Install the gasket on the crankcase.

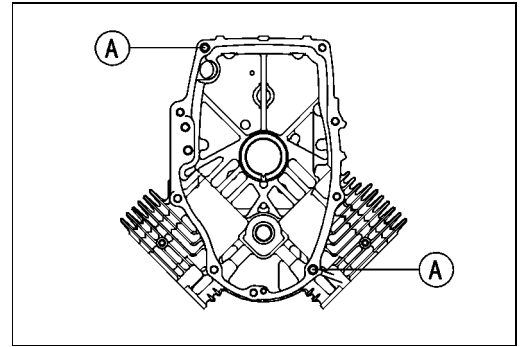

- Install the crankcase cover and tighten the crankcase cover bolts following the tightening sequence shown.

Torque - Crankcase Cover Bolts: 25 N·m (2.6 kgf·m, 19.0 ft·lb)

- Do not turn one bolt down completely before the others, as it may cause the crankcase cover to warp.

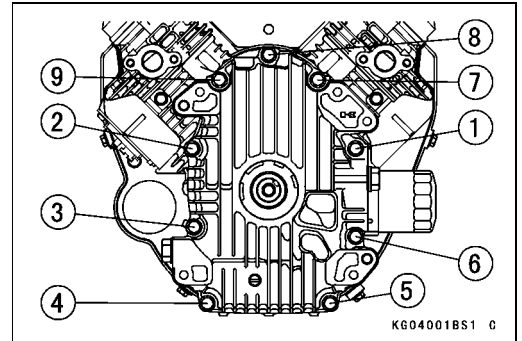

Inspection

- Measure the inside diameter [A] of the PTO shaft bearing on the crankcase cover at several points. This bearing is not replaceable. Replace the crankcase cover if the inside diameter is more than the service limit.

PTO Shaft Bearing Inside Diameter

Service Limit: 35.15 mm (1.384 in.)

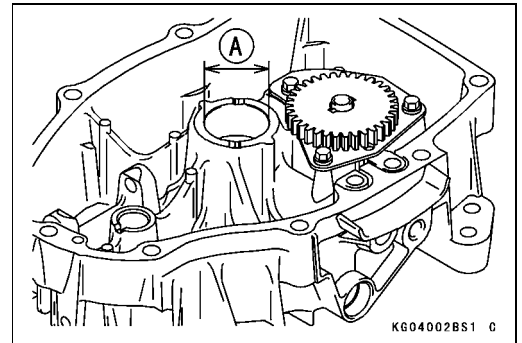

- Measure the inside diameter [A] of the crankshaft journal bearing on the crankcase at several points. This bearing is not replaceable. Replace the crankcase if the inside diameter is more than the service limit.

Crankshaft Journal Bearing Inside Diameter

Service Limit: 35.15 mm (1.384 in.)



Cleaning

- Remove:
 - Camshaft and Tappets (see Camshaft, Tappet Removal)
 - Crankshaft (see Crankshaft Removal)
- Clean up the crankcase and cover with a high flash-point solvent, and blow out any foreign particles that may be in the pockets inside of the crankcase with compressed air.

⚠ WARNING

Clean the crankcase and cover in a well-ventilated area, and take care that there is no spark or flame anywhere near the working area. Because of the danger of highly flammable liquids, do not use gasoline or low flash-point solvents.

7-6 CAMSHAFT/CRANKSHAFT

Breather

The function of the breather is to create a vacuum in the crankcase which prevents oil from being forced out of the engine through the piston rings, oil seals or gaskets. A sealed-type crankcase emission control system is used to eliminate blow-by gases. The blow-by gases are led to the breather chamber through the crankcase and the camshaft. Then, it is drawn into the clean side of the air cleaner through the cylinder head and the hose and mixed with the clean air flow, and subsequently comes into the combustion chamber through the carburetor and the intake manifold.

Oil is primarily separated from the gases while passing through the inside of the rocker chamber from the crankcase, and secondly separated from the gases in the breather chamber, and then returned back to the crankcase cover.

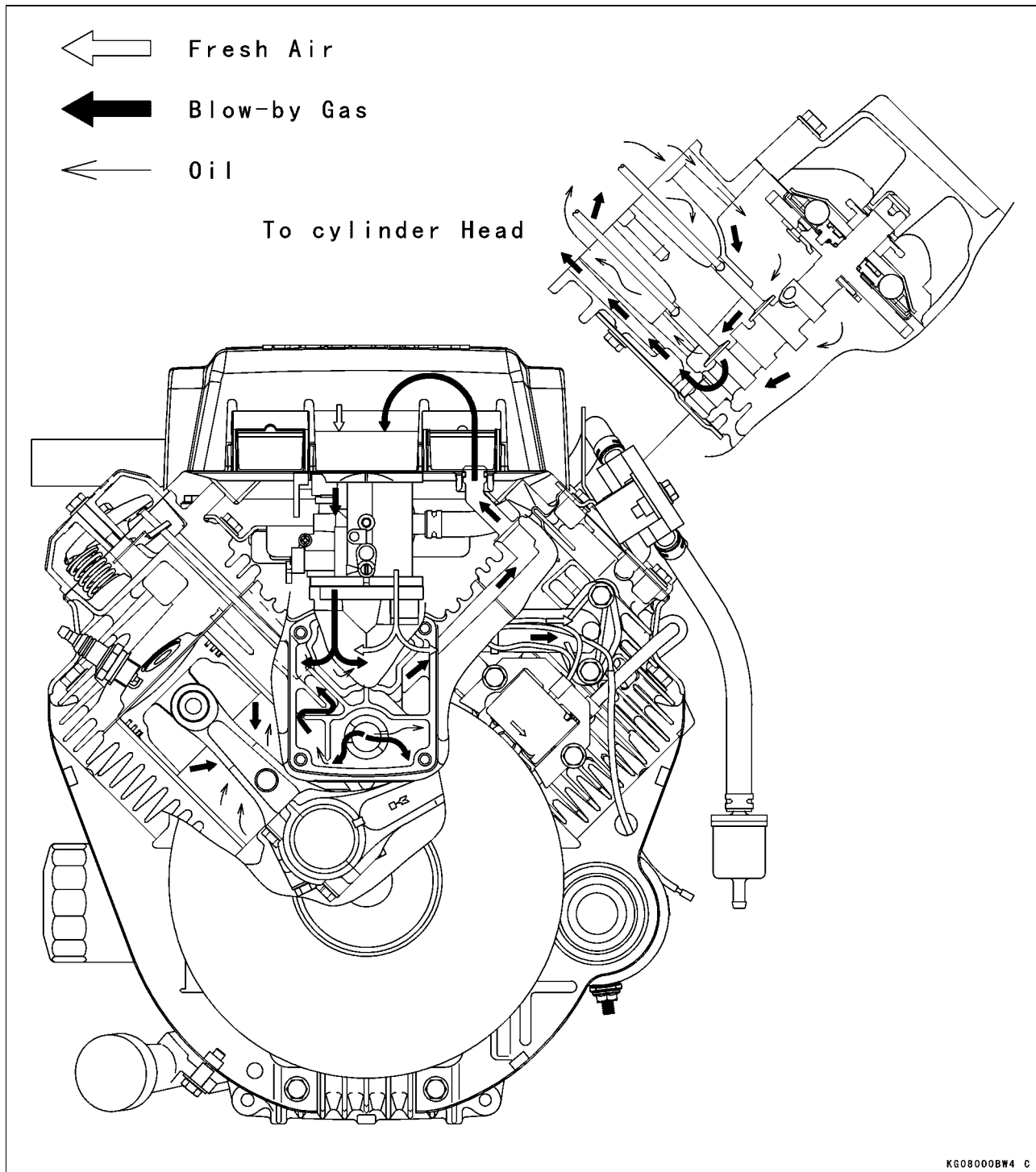

Breather

Breather Chamber Cover Removal

- Remove the bolts [A] and breather chamber cover [B].

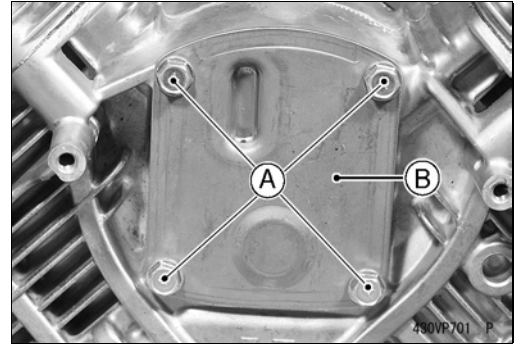

Breather Chamber Cover Installation

- Apply sealant [A] to the mating surface of the crankcase.
 - Sealant - **Bond (Silicone Sealant) : 56019-120**
- Install a new gasket and the breather chamber cover, and tighten the bolts.
 - Torque - **Breather Chamber Cover Bolts: 5.9 N·m (0.60 kgf·m, 52 in·lb)**

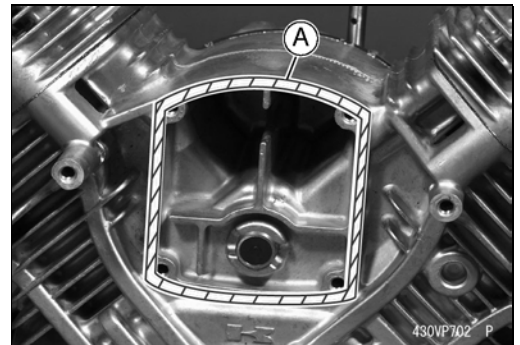

7-8 CAMSHAFT/CRANKSHAFT

Camshaft, Tappet

Camshaft, Tappet Removal

- Set the engine on a clean surface while parts are being removed.
- Drain the oil (see Lubrication System chapter).
- Remove:

- Muffler (see Engine Top End chapter)
- Throttle Control Panel (see Fuel System chapter)
- Carburetor (see Fuel System chapter)
- Intake Manifold (see Fuel System chapter)
- Crankcase Cover (see Crankcase Cover Removal)
- Rocker Covers [A]

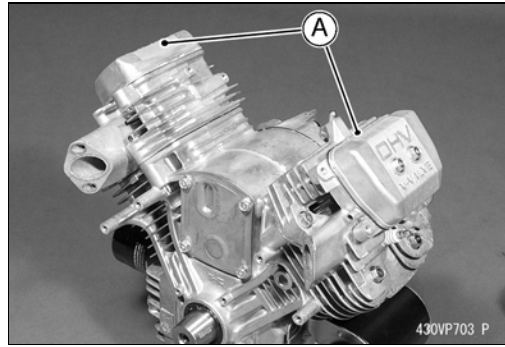

- Position the piston TDC at the end of the compression stroke.
- Push down [A] the spring side of the rocker arm [B] and move it to clear the push rod [C].
- Remove the push rods and mark them so they can be installed in their original positions during assembly.

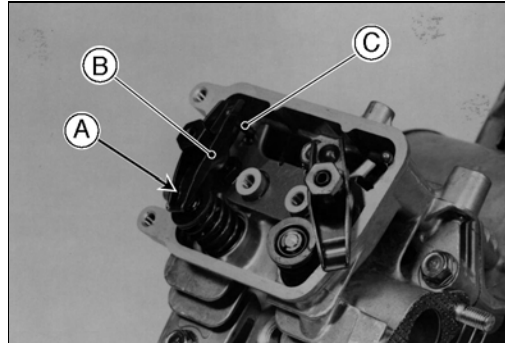

- Turn the crankcase up side down so that the tappets will fall away from the cam lobes.
- Pull the camshaft [A] out of the crankcase.

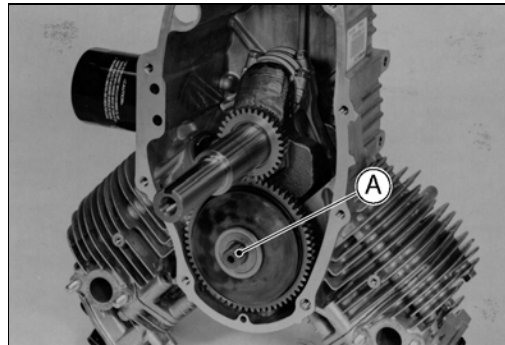

- Remove the tappets [A] and mark them so they can be installed in their original positions during assembly.

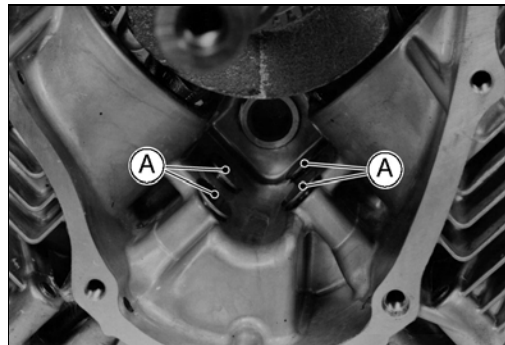

Camshaft, Tappet Installation

- Apply engine oil to the following.
 - Tappet Journal
 - Camshaft Journal
 - Cam Lobe Surface
 - Camshaft Gear
- Align the punch marks [A] on the crankshaft gear and camshaft gear.
- Install the shim [B] on the camshaft.

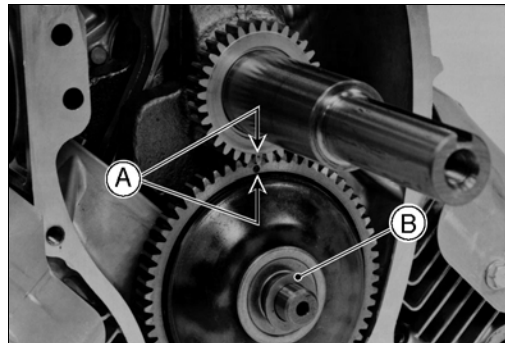

Camshaft, Tappet

Camshaft Disassembly

- Remove the governor assembly (see Fuel System chapter).
- Remove:
 - Spring [A]
 - Do not remove the ACR (automatic compression release) weight [B].

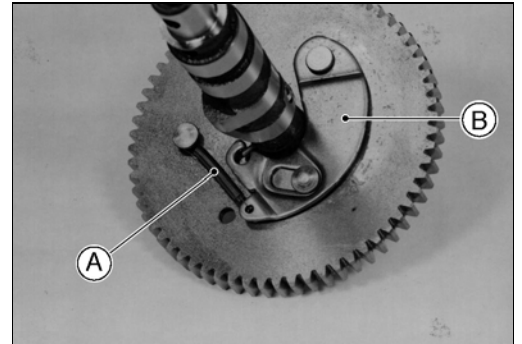

Camshaft Assembly

- Install the governor assembly (see Fuel System chapter).
- After assembling the camshaft, check the following items.
 - The governor plate [A] must move freely.
 - While shaking the camshaft, ACR weight [B] swings smoothly.

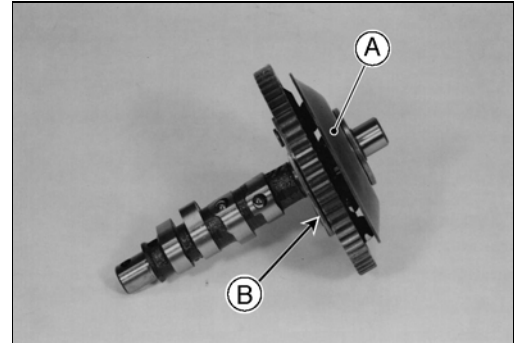

Camshaft Inspection

- Check the camshaft gear [A] for pitting, fatigue cracks, burrs or an evidence of improper tooth contact.
 - ★ Replace the shaft if necessary.
- Check the top of the cam lobes [B] for wear, burrs or uneven contact.
 - ★ Replace the shaft if necessary.

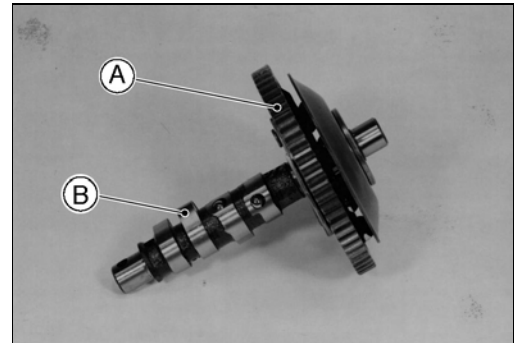

Camshaft Bearing/Journal Wear

- Measure the height of each cam lobe.
- ★ If the cam height is less than the service limit for either lobe, replace the camshaft.

Cam Lobe Height

Service Limit: **IN. 29.131 mm (1.1469 in)**
 EX. 29.131 mm (1.1469 in)



- Measure both camshaft journals at several points around the journal circumference.
- ★ If the journal diameter is less than the service limit, replace the camshaft.

PTO Side Camshaft Journal Diameter

Service Limit: **15.985 mm (0.6293 in.)**

Flywheel Side Camshaft Journal Diameter

Service Limit: **15.985 mm (0.6293 in.)**

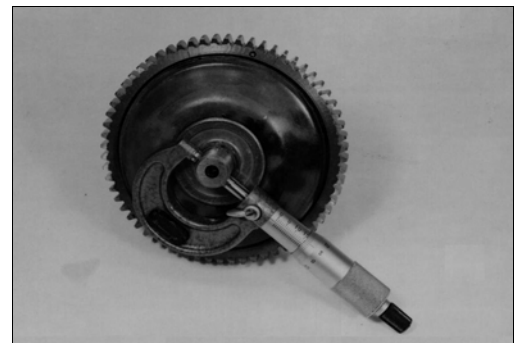

7-10 CAMSHAFT/CRANKSHAFT

Camshaft, Tappet

- Measure the inside diameter [A] of the camshaft bearing on the crankcase at several points. This bearing is not replaceable.
- ★ Replace the crankcase if the inside diameter is more than the service limit.

Camshaft Bearing Inside Diameter (Crankcase)

Service Limit: 16.136 mm (0.6352 in.)

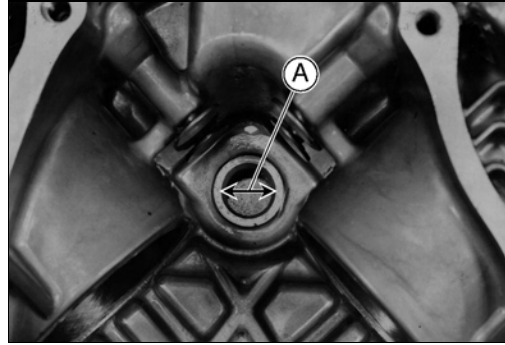

- Measure the inside diameter [A] of the camshaft bearing on the crankcase cover at several points. This bearing is not replaceable.
- ★ Replace the crankcase cover if the inside diameter is more than the service limit.

Camshaft Bearing Inside Diameter (Crankcase Cover)

Service Limit: 16.136 mm (0.6352 in.)

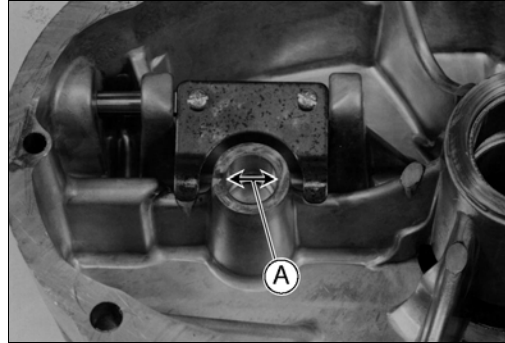

Crankshaft, Connecting Rod

Connecting Rod Removal

- Remove:
 - Piston (see Engine Top End chapter)

Connecting Rod Installation

- Install:
 - Piston (see Engine Top End chapter)

Crankshaft Removal

- Set the engine on a clean surface while parts are being removed.
- Drain the oil (see Lubrication System chapter).
- Remove:
 - Flywheel (see Electrical System chapter)
 - Camshaft (see Camshaft, Tappet Removal)
 - Connecting Rod and Piston Assembly (see Engine Top End chapter)
- Pull the crankshaft [A] out of the crankcase. Tap gently with a wooden or plastic mallet if necessary to loosen the crankshaft.

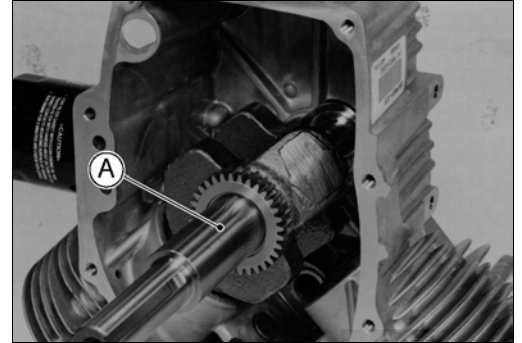

Crankshaft Installation

- Clean up the crankshaft and crankcase thoroughly, especially at the bearing contact surfaces.
- Pack some amount of high temperature grease into the oil seal on the crankcase.
- Apply engine oil to the PTO side, journal crank pin and bearing.
- Apply molybdenum disulfide grease.
- Carefully insert the crankshaft flywheel end into the main bearing and oil seal in the crankcase.

Cleaning/Inspection

- After removing, clean the crankshaft and connecting rods with a high flash-point solvent and dry them with compressed air.
- Inspect the teeth of the crankshaft gear for pitting, fatigue cracks, burrs and evidence of improper tooth contact.
- ★ Replace the gear if necessary.
- Inspect the crankshaft and connecting rods especially at the bearing surfaces for wear, scratches, evidence of improper contact or other damages.
- ★ Replace them if necessary.

Connecting Rod Bend/Twist

- Measure connecting rod bend.
 - Select an arbor of the same diameter as the connecting rod big end, and insert the arbor through the connecting rod big end.
 - Select an arbor of the same diameter as the piston pin and at least 100 mm long, and insert the arbor through the connecting rod small end.
 - On a surface plate, set the big-end arbor on V blocks.
 - With the connecting rod held vertically, use a height gauge to measure the difference in the height of the small end arbor above the surface plate over a 100 mm length to determine the amount of connecting rod bend.
- ★ If connecting rod bend exceeds the service limit, the connecting rod must be replaced.

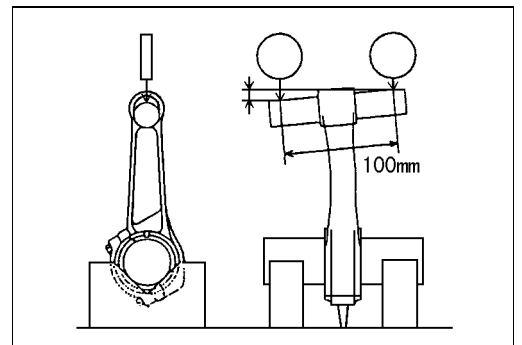

Connecting Rod Bend

Service Limit: 0.15/100 mm (0.006/3.94 in.)

7-12 CAMSHAFT/CRANKSHAFT

Crankshaft, Connecting Rod

- Measure connection rod twist.
- With the big-end arbor still on the V blocks, hold the connection rod horizontally and measure the amount that the small end arbor varies from being parallel with the surface plate over a 100 mm length of the arbor to determine the amount of connecting rod twist.
- ★ If connection rod twist exceeds the service limit, the connecting rod must be replaced.

Connecting Rod Twist

Service Limit: 0.15/100 mm (0.006/3.94 in.)

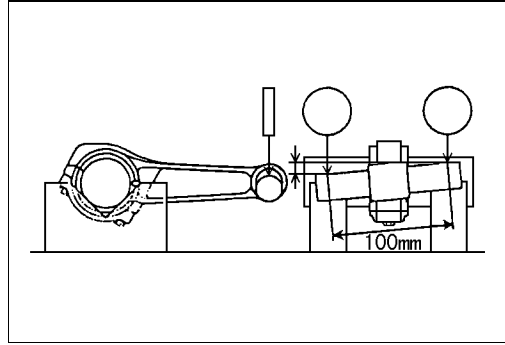

Connecting Rod Big End/Crankpin Width Wear

- Measure the connecting rod big end width [A] with a micrometer or dial caliper.
- ★ If the measurement is less than the service limit, replace the connecting rod.

Connecting Rod Big End Width

Service Limit: 18.80 mm (0.74 in.)

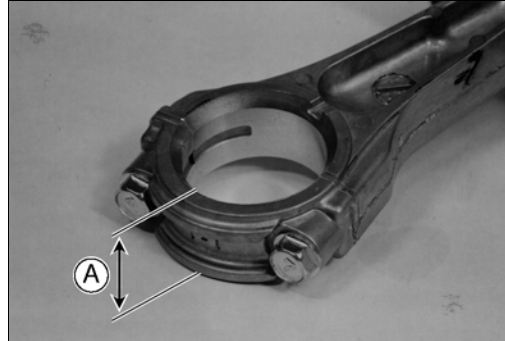

- Measure the crankpin width [A] with a dial caliper.
- ★ If the crankpin width is more than the service limit, replace the crankshaft.

Crankpin Width

Service Limit: 39.50 mm (1.56 in.)

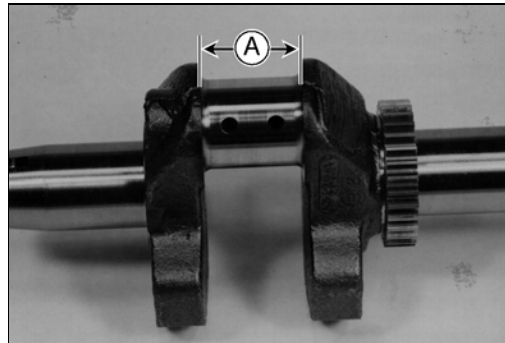

Connecting Rod Big End Bearing/Crankpin Wear

- Apply a light film of oil on the thread of the cap bolts.
- Install the cap bolts and tighten the bolts to the specified torque (see Piston Installation in Engine Top End chapter).
- Measure the inside diameter [A] of big end at several points with a telescoping gauge or inside micrometer.
- ★ If the inside diameter is more than the service limit, replace the connecting rod with a new one.

Connecting Rod Big End Inside Diameter

Service Limit: 33.055 mm (1.301 in.)

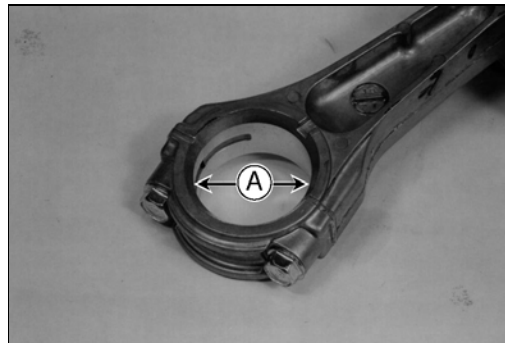

- Measure the crankpin outside diameter [A].
- Use a micrometer to measure several points around the crankpin circumference.
- ★ If the crankpin diameter is less than the service limit, replace the crankshaft with a new one.

Crankpin Outside Diameter

Service Limit: 32.94 mm (1.297 in.)

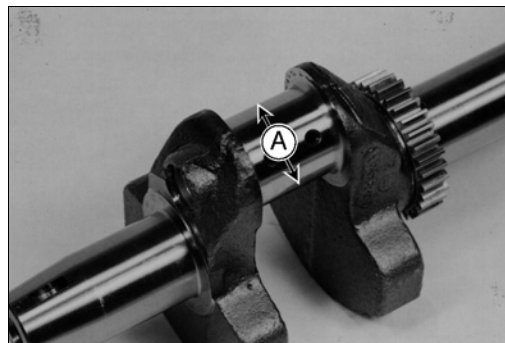

Crankshaft, Connecting Rod

Crankshaft Runout

- Measure the crankshaft runout.
- Set the crankshaft in a flywheel alignment jig or on V blocks gauge.
- Set a dial gauge against both bearing journals.
- Turn the crankshaft slowly to measure the runout. The difference between the highest and lowest dial gauge readings (TIR) is the amount of runout.
- ★ If the measurement exceeds the service limit, replace the crankshaft.

Crankshaft Runout

Service Limit: 0.05 mm (0.002 in.) TIR

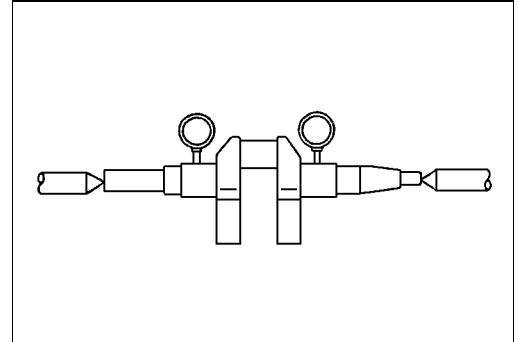

Crankshaft Main Journal/Wear

- Measure both main journals at several points around the journal circumference.
- ★ If the journal diameter is less than the service limit, replace the crankshaft with a new one.

PTO Side Crankshaft Journal Diameter [A]

Service Limit: 34.90 mm (1.374 in)

Flywheel Side Crankshaft Journal Diameter [B]

Service Limit: 34.94 mm (1.376 in.)

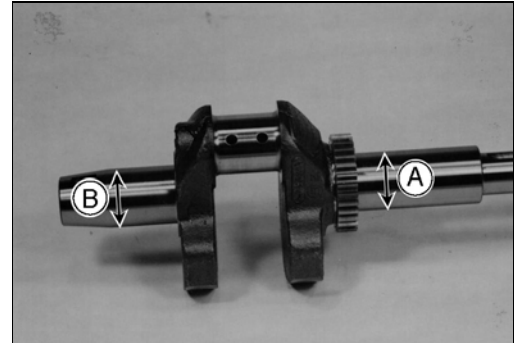

Crankpin Resizing

Crankpin can be resized to accept 32.5 mm (1.2795 in.) dia under size connecting rod. The crankpin should be reground if the crankpin is so much undersized and so much scored that a lapping operation will prove unsatisfactory. Regrinding can be done by a reliable repair shop.

- Before sending the crankshaft, inspect the crankpin for cracks.
- ★ If any cracks, no matter how small, are found, the crankshaft must be rejected.
- The final finishing dimensions should be shown in the table.

Finishing Dimensional Specifications

[A]	32.470 ~ 32.457 mm (1.278 ~ 1.277 in.)
[B]	R 2.0 ~ 2.4 mm
[C]	39.50 mm MAX (1.555 in. MAX)
[D]	34.550 ~ 32.450 mm (1.281 ~ 1.278 in.)

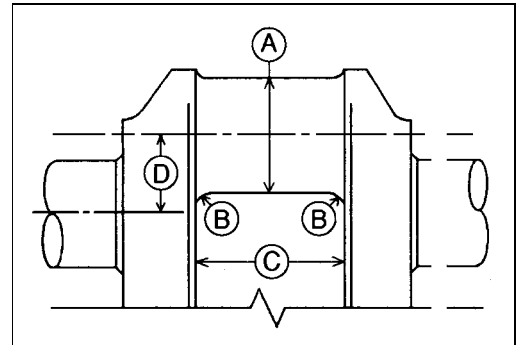

- The crankpin surface should be concentric and parallel to each other within 0.006 mm (0.0002 in.) full indicator reading.
- Finish the crankpin surface with a super finishing stone.

Electrical System

Table of Contents

- Exploded View.....8-2
- Specifications.....8-4
- Wiring Diagram8-5
- Precautions8-8
- Charging, Ignition System.....8-9
 - Flywheel, Stator Coil Removal.....8-9
 - Flywheel, Stator Coil Installation.....8-10
 - Charging System Operational Inspection.....8-11
 - Stator Coil Resistance.....8-12
 - Unregulated Stator Output.....8-12
 - Regulator Removal.....8-12
 - Regulator Installation.....8-12
 - Regulator Resistance.....8-13
 - Ignition Coil Removal.....8-15
 - Ignition Coil Installation.....8-15
 - Ignition Coil Inspection.....8-16
 - Spark Plug Removal.....8-16
 - Spark Plug Installation.....8-16
 - Spark Plug Cleaning and Inspection.....8-16
 - Spark Plug Gap Inspection.....8-16
- Starter System8-17
 - Starter Motor Removal.....8-17
 - Starter Motor Installation.....8-17
 - Starter Motor Disassembly.....8-17
 - Starter Motor Assembly8-18
 - Starter Motor Brush Inspection.....8-18
 - Brush Spring Inspection.....8-18
 - Armature Inspection.....8-19
 - Pinion Clutch Inspection.....8-20
 - Recoil Starter Removal.....8-20
 - Recoil Starter Installation.....8-20
 - Recoil Starter Disassembly.....8-20
 - Recoil Starter Assembly.....8-22

8-2 ELECTRICAL SYSTEM

Exploded View

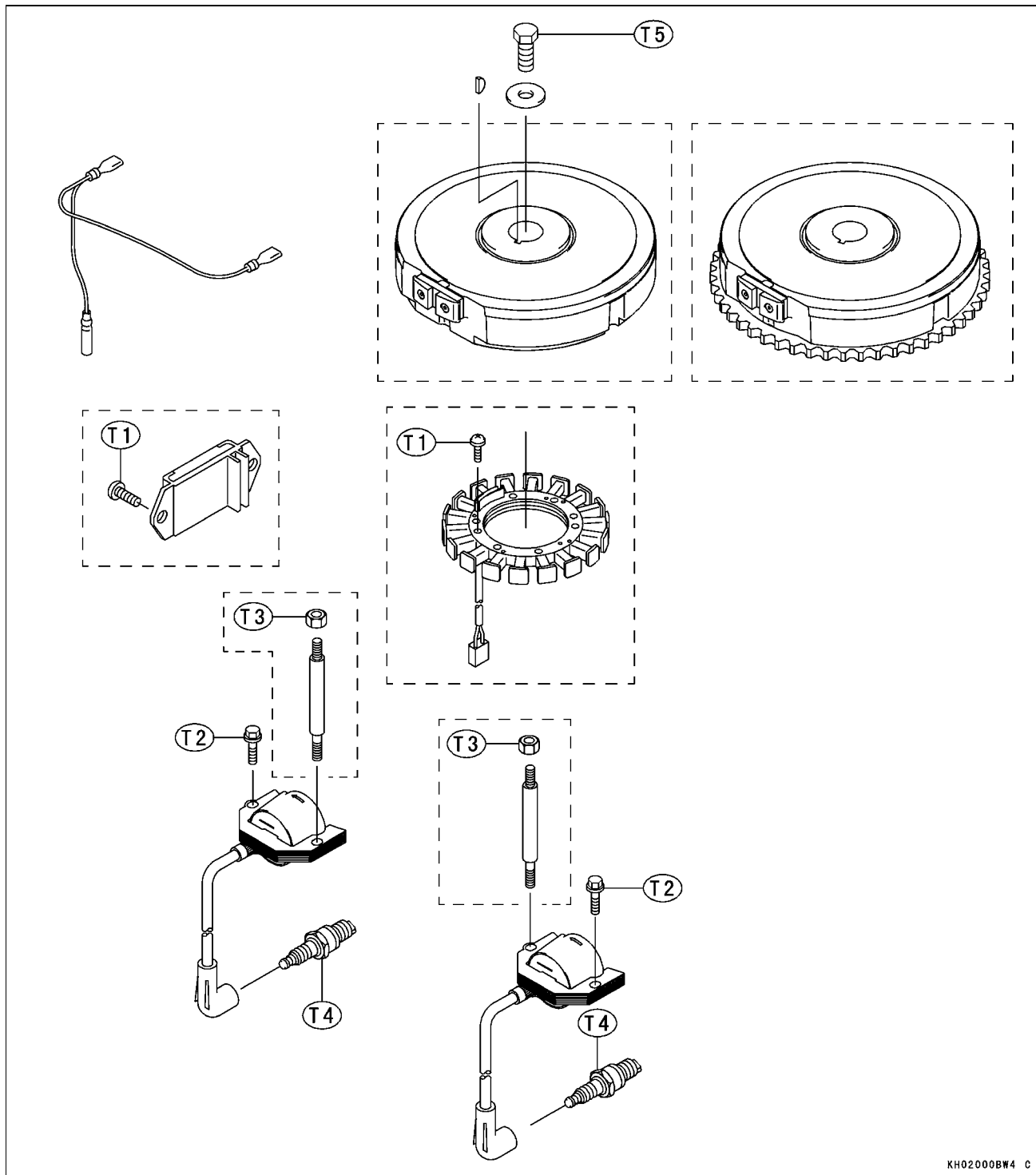

KH02000BW4 C

T1: 3.4 N·m (0.35 kgf·m, 30 in·lb)

T2: 5.9 N·m (0.60 kgf·m, 52 in·lb)

T3: 7.8 N·m (0.80 kgf·m, 69 in·lb)

T4: 22 N·m (2.2 kgf·m, 16 ft·lb)

T5: 56 N·m (5.7 kgf·m, 41 ft·lb)

Exploded View

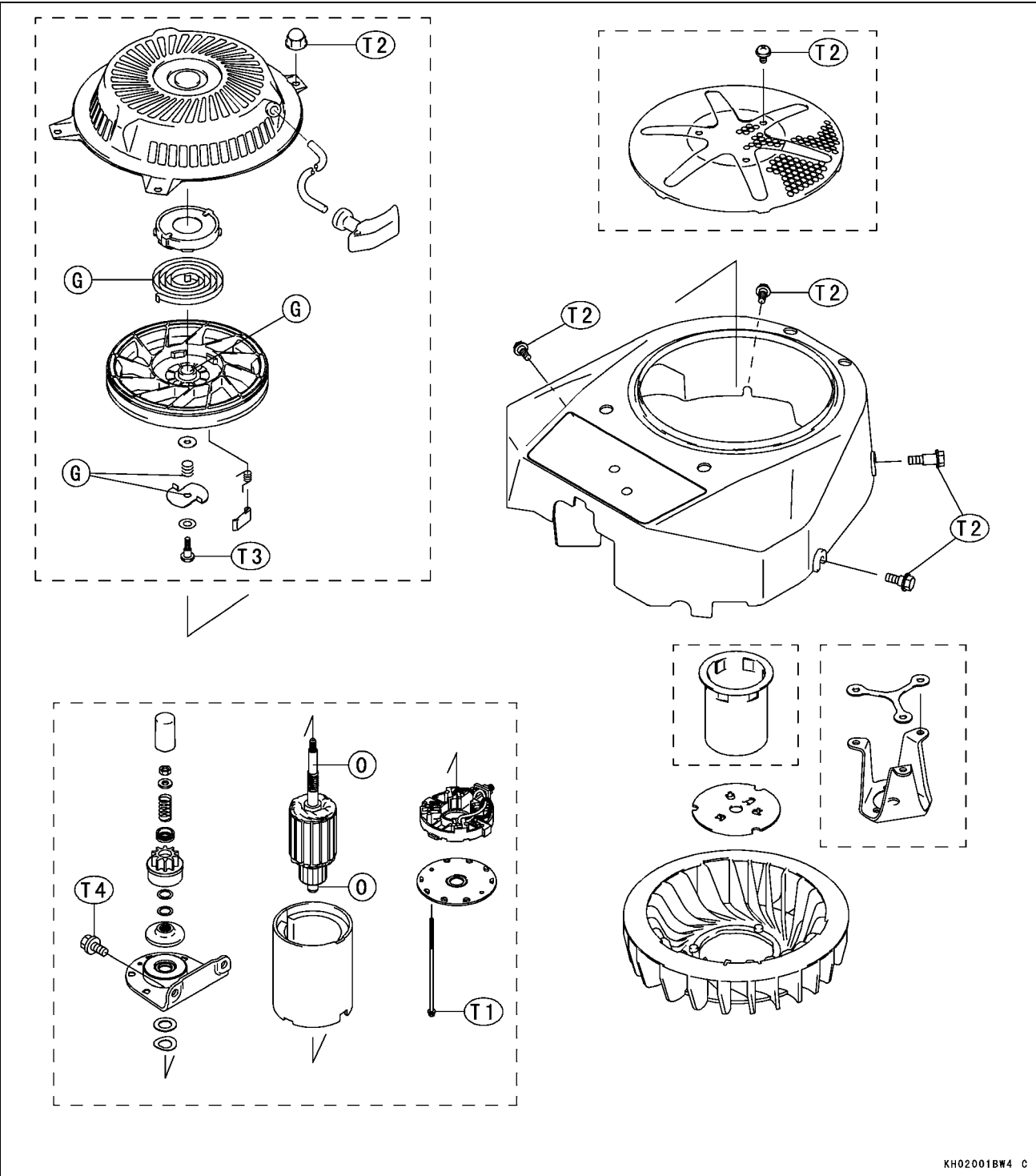

KH02001BW4 C

- T1: 3.9 N·m (0.40 kgf·m, 35 in·lb)
- T2: 5.9 N·m (0.60 kgf·m, 52 in·lb)
- T3: 7.8 N·m (0.80 kgf·m, 69 in·lb)
- T4: 15 N·m (1.5 kgf·m, 11 ft·lb)

- G: Apply grease.
- O: Apply engine oil.

8-4 ELECTRICAL SYSTEM

Specifications

Item	Standard	Service Limit
Charging System:		
Regulated output voltage	14.1 V DC/3600 rpm	15 V DC/3600 rpm
Alternator stator coil resistance	in the text	---
Unregulated stator output	28.4 V AC/3000 rpm	26V AC/3000 rpm
Regulator resistance	in the text	
Ignition System:		
Ignition coil:		
Primary winding resistance	in the text	---
Secondary winding resistance	8 to 11 k Ω	---
Spark Plug	CHAMPION RCJ8Y	---
Plug gap	0.75 mm (0.030 in.)	---
Electric Starter System:		
Starter motor:		
Carbon brush length (with spring boss)	12.0 mm (0.500 in.)	4.0 mm (0.157 in.)
Commutator groove depth (approx)	2.0 mm (0.078 in.)	1.0 mm (0.039 in.)
Commutator diameter	31.5 mm (1.240 in.)	29.5 mm (1.161 in.)
Commutator runout	---	0.0178 mm (0.007 in.)

Special Tool - Hand Tester: 57001-1394

Wiring Diagram

Note: Portion surrounded by /// shows KHI procurement parts

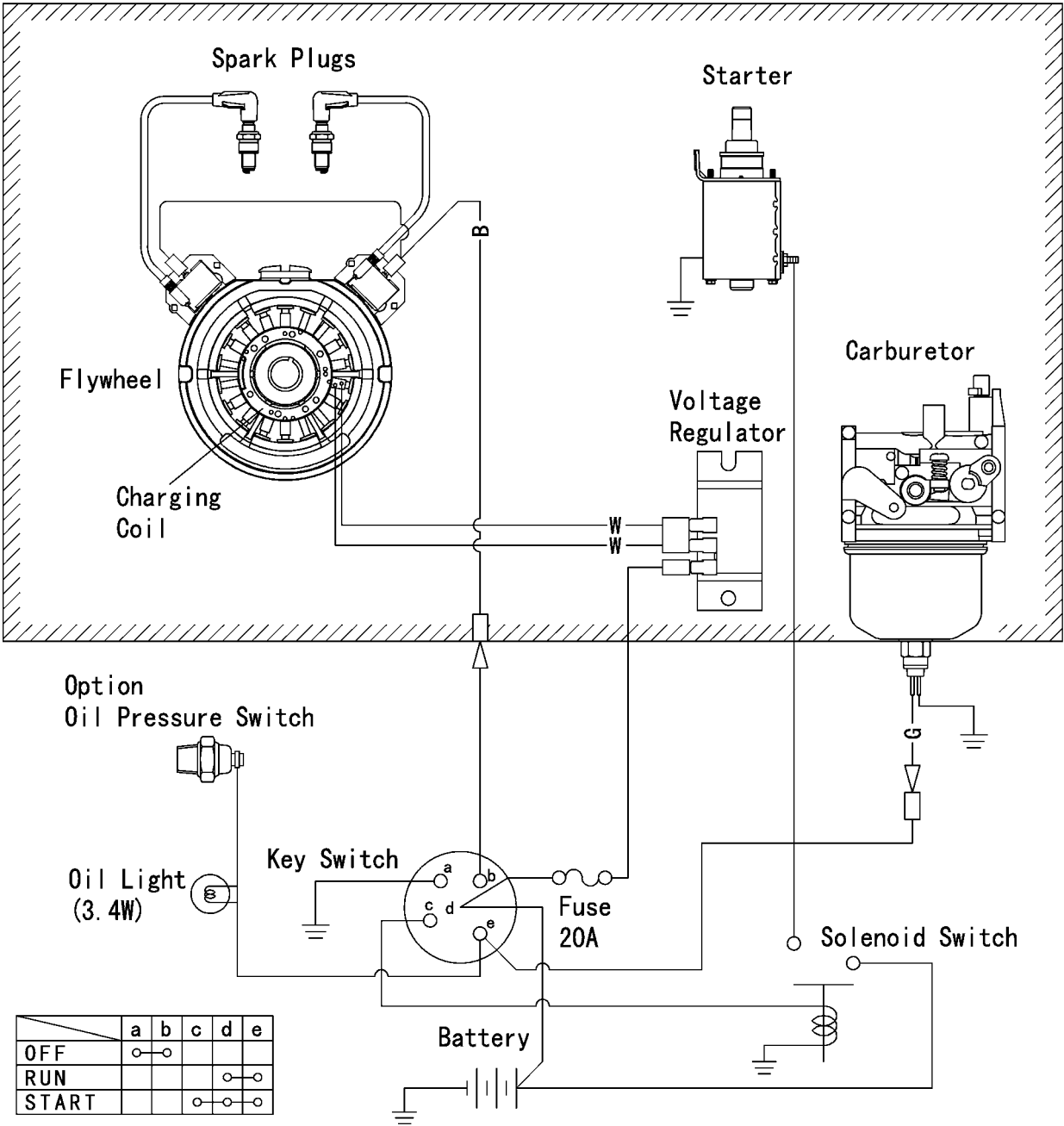

8-6 ELECTRICAL SYSTEM

Wiring Diagram

Note: Portion surrounded
by /// shows KHI
procurement parts

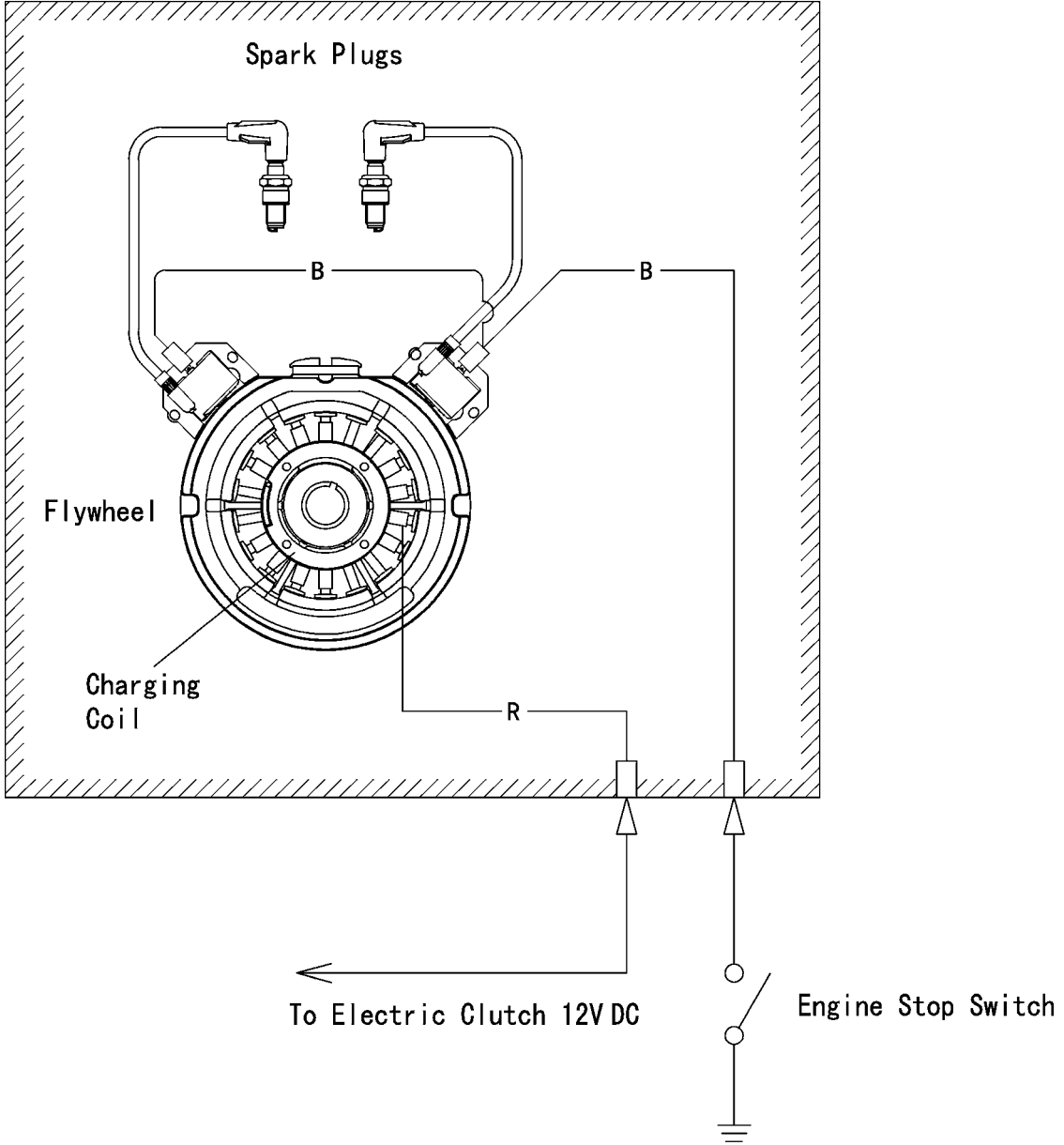

Wiring Diagram

Note: Portion surrounded by /// shows KHI procurement parts

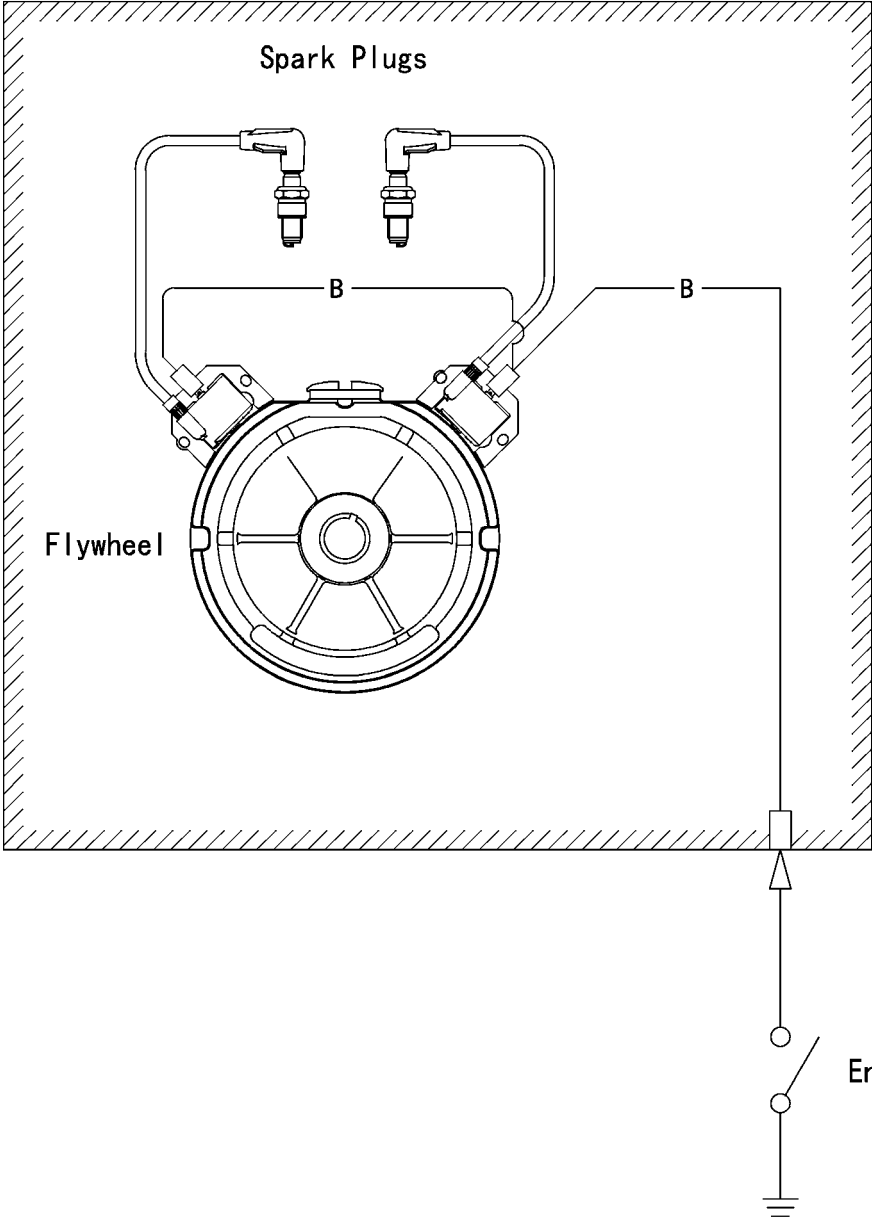

8-8 ELECTRICAL SYSTEM

Precautions

There are a number of important precautions that are musts when servicing electrical systems. Learn and observe all the rules below.

- Do not reverse the battery lead connections. This will burn out the diodes in the electrical parts.
- Always check battery condition before condemning other parts of an electrical system. A fully charged battery is a must for conducting accurate electrical system tests.
- The electrical parts should never be struck sharply, as with a hammer, or allowed to fall on a hard surface. Such a shock to the parts can damage them.
- To prevent damage to electrical parts, do not disconnect the battery leads or any other electrical connections when the engine switch is on, or while the engine is running.
- Because of the large amount of current, never keep the engine switch turned to the start position when the starter motor will not turn over, or the current may burn out the starter motor windings.
- Take care not to short the leads that directly connect the battery positive (-) terminal to the chassis ground.
- Troubles may involve one or in some cases all items. Never replace a defective part without determining what CAUSED the failure. If the failure was brought on by some other item or items, they too must be repaired or replaced, or the replacement part will soon fail again.
- Make sure all connectors in the circuit are clean and tight, and examine wires for signs of burning, fraying, etc. Poor wires and bad connections will affect electrical system operation.
- Measure coil and winding resistance when the part is cold (at room temperature).
- Electrical Connectors:

Female Connectors [A]

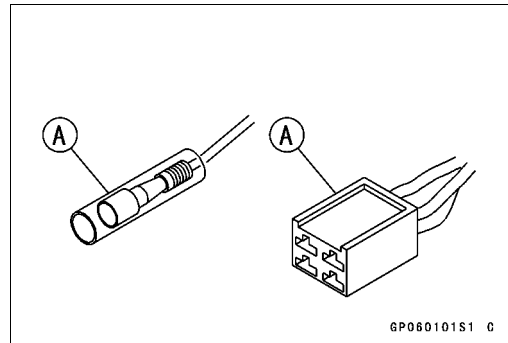

Male Connectors [B]

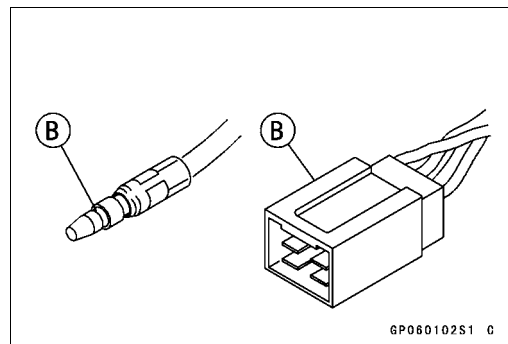

Charging, Ignition System

Flywheel, Stator Coil Removal

- Remove:
 - Recoil Starter (see Recoil Starter Removal)
 - Nuts [A] and Guard [B]
 - Screws [C] and Screen [D]
 - Spacer [E]

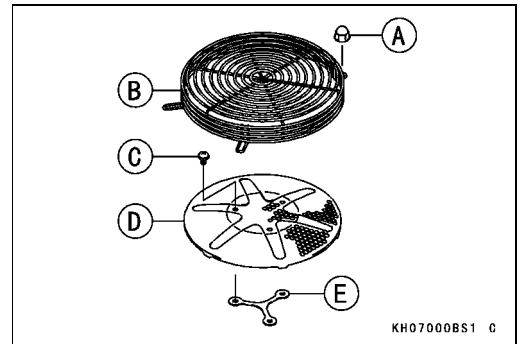

- Loosen the fan housing bolts [A] and remove the fan housing [B].

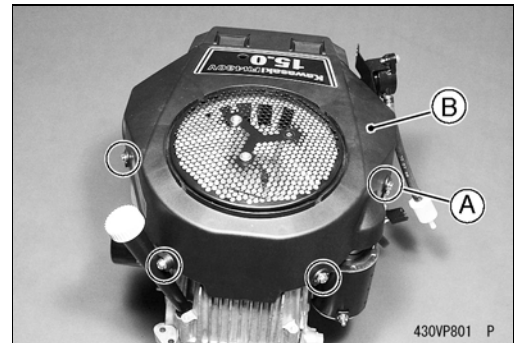

- Remove:
 - Ignition Coils (see Ignition Coil Removal)
 - Stud Bolts [A]

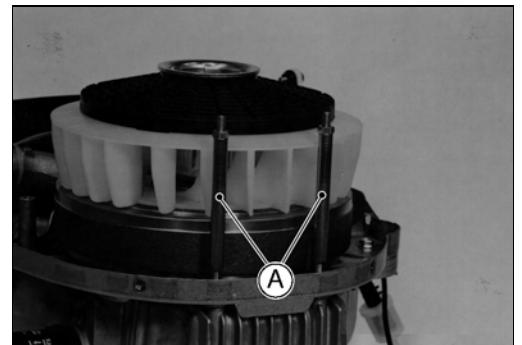

- Hold the flywheel with a suitable tool, remove the flywheel bolt and washer.

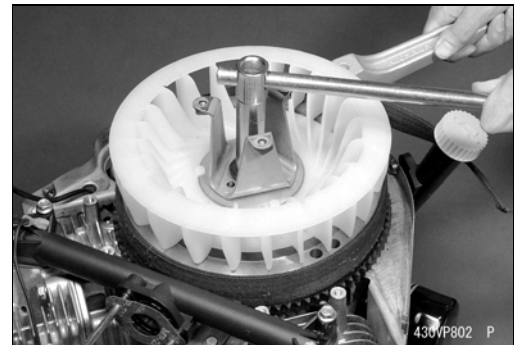

- Using a suitable flywheel puller [A], remove the flywheel [B].

CAUTION
Always use flywheel puller.

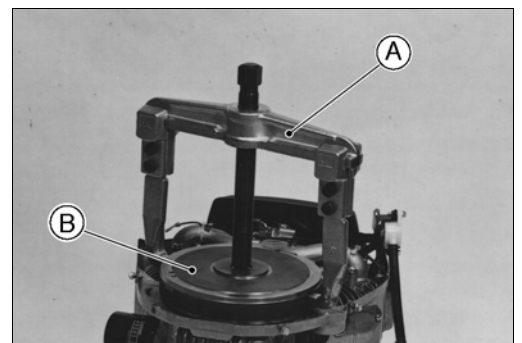

8-10 ELECTRICAL SYSTEM

Charging, Ignition System

- Remove:
 - Woodruff Key [A]
 - Stator Coil Lead Connector [B]
 - Stator Coil Screw [C]
 - Stator Coil [D]

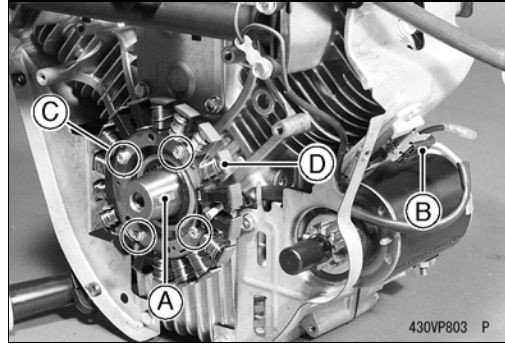

Flywheel, Stator Coil Installation

- Install the stator coil and tighten the screws.
 - Torque - Stator Coil Screws: 3.4 N·m (0.35 kgf·m, 30 in·lb)**
- Using a cleaning fluid, clean off any oil or dirt on the following portions and dry them with a clean cloth.
 - [A] Crankshaft Tapered Portion
 - [B] Flywheel Tapered Portion
- Fit the Woodruff key [C] securely in the slot in the crankshaft before installing the flywheel.
- Install the flywheel onto the crankshaft taper so that the woodruff key fits in the key way in the hub of the flywheel.
- Install the fan [A] so that two positioning bosses [B] fit around flywheel ignition magnet [C].
- Install the plate [D] so that the notch [E] inserts into the slot in the flywheel.
- Install the screen [A] so that the projections [B] fit into the recess [C] of the fan (Recoil starter model).

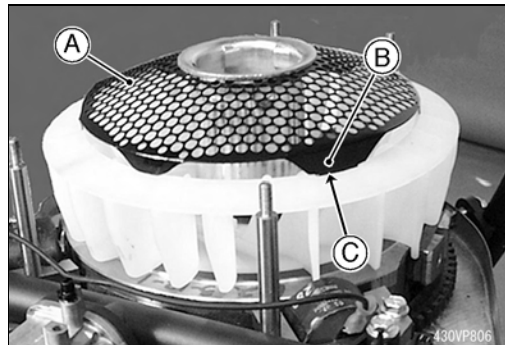
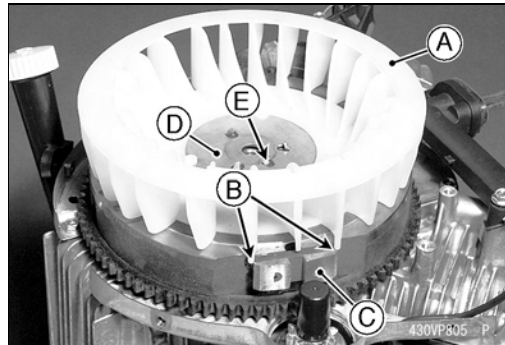
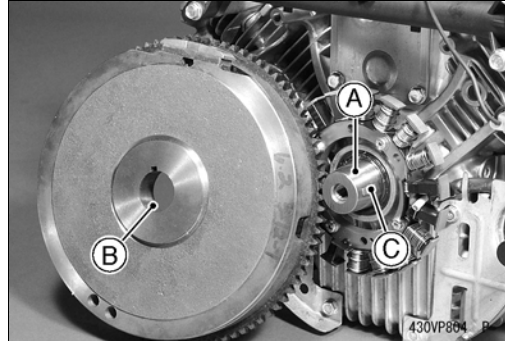

- Install the pulley or bracket [A] so that the tabs of the plate fit into holes [B].
- Put the washer [C] as shown.
- Tighten the flywheel bolt [D].
 - Torque - Flywheel Bolt: 56 N·m (5.7 kgf·m, 41 ft·lb)**

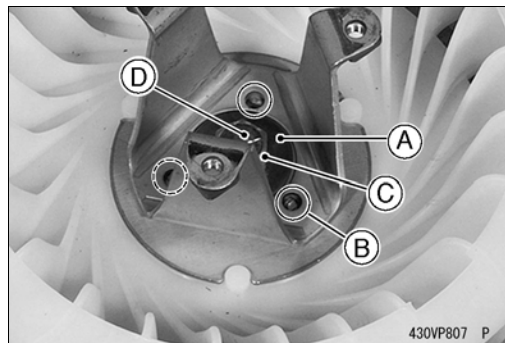

Charging, Ignition System

- Install the fan housing and tighten the bolts.
 - Torque - Fan housing Bolts: 5.9 N·m (0.60 kgf·m, 52 in·lb)**
- Install:
 - Recoil Starter (see Recoil Starter Installation)
- Install:
 - Spacer [A]
 - Screen [B]
- Position three sets [C] of screen notches around the fan blades.
- Tighten the screen screws [D].
 - Torque - Screen Screws: 5.9 N·m (0.60 kgf·m, 52 in·lb)**

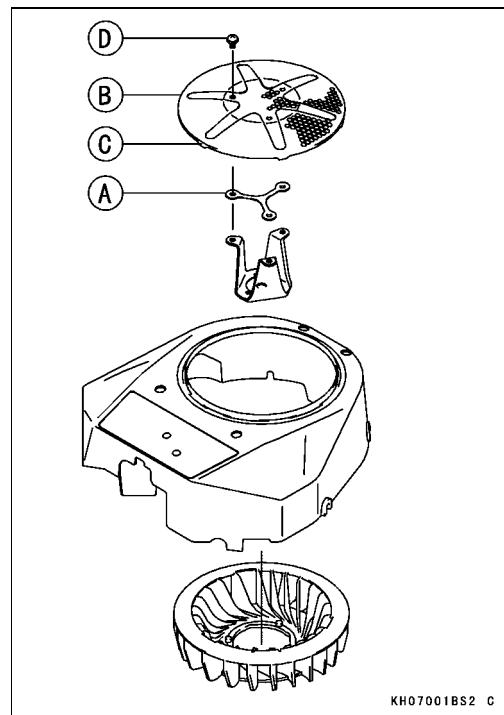

Charging System Operational Inspection

- Check battery condition.

NOTE

- Always check battery condition before condemning other parts of the charging system. The battery must be fully charged in order to conduct accurate charging system tests.
- Warm up the engine to bring the components up to their normal operating temperatures.
- Measure regulated output voltage at various engine speeds.
- Connect a voltmeter across the battery terminals.
- ★ The readings should show nearly battery voltage when the engine speed is low, and as the engine speed rises, the readings should also rise. But they must stay within the specified range.
- ★ If the output voltage is much higher than the specification, the regulator is defective, or the regulator leads are loose or open.
- ★ If the output voltage does not rise as the engine speed increases, the regulator is defective or the alternator output is insufficient for the loads.

Regulated Output Voltage

Battery Voltage to 15 VDC/3600 rpm

8-12 ELECTRICAL SYSTEM

Charging, Ignition System

Stator Coil Resistance

- Disconnect the connector [A].
- Measure the stator coil resistance.
(Electric Starter Model)
- Connect an ohmmeter between stator pins [B].

Stator Coil Resistance (Electric Starter Model)

0.01 to 0.1 Ω

(Recoil Starter Model with Electric Clutch)

- Connect an ohmmeter between stator pin and engine-body.

Stator Coil Resistance (Recoil Starter Model with Electric Clutch)

4.4 to 15 Ω

- ★ If the meter does not read as specified, replace the stator coil.
- ★ If the coil has normal resistance, but the voltage inspection showed the alternator to be defective; the flywheel magnets have probably weakened, and the flywheel must be replaced.
- Check for continuity between each stator pin and ground. There should be no continuity (infinite ohm).
- ★ If the stator coil fails any of these tests, replace the coil with a new one.

Unregulated Stator Output

- Disconnect the connector [A].
- Connect AC voltmeter to the stator pins [B].
- Start the engine. Run the engine at the 3 000 rpm speed.
- Voltage reading should be minimum 26 VAC/3 000 rpm.
- ★ If the AC voltage reading is less than the specification, replace the stator.

Unregulated Stator Output (MIN)

26 VAC/3 000 rpm

Regulator Removal

- Remove:
 - Stator Coil Lead Connector [A]
 - Regulator Screws [B]
 - Regulator [C]

Regulator Installation

- Install the regulator and tighten the screws.
Torque - Regulator Screws: 3.4 N·m (0.35 kgf·m, 30 in·lb)

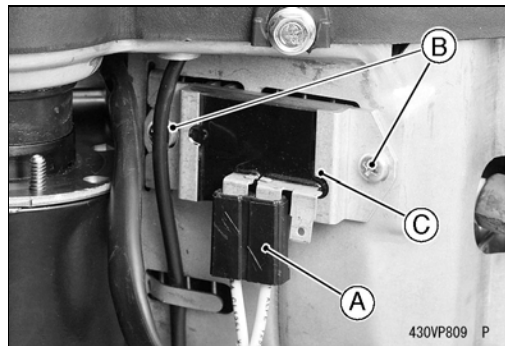
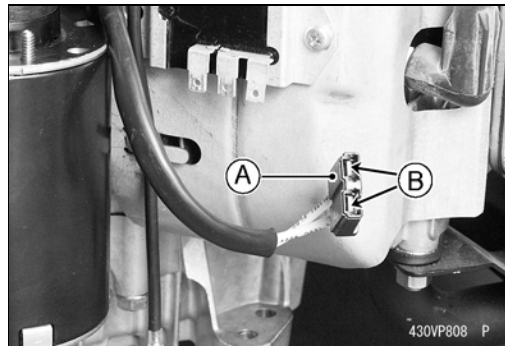
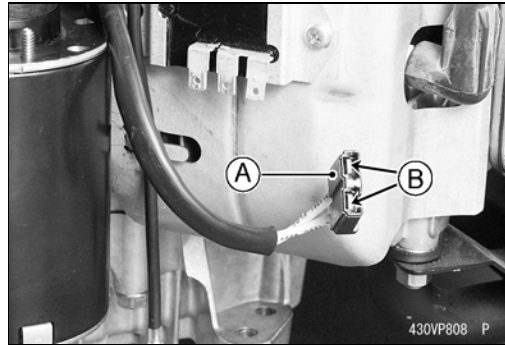

Charging, Ignition System

Regulator Resistance

- Set the Hand Tester selector switch to the $R \times 100 \Omega$ position.
- Connect the test leads to the points shown on the chart and read the resistance.
- There are two(2) types of Regulator on FH engines as follows:

(with out Charging Monitor Type ...3 Blades)

+	A	B	C	D
-	A	B	C	D
A	∞	∞	∞	∞
B	∞	0	500 $\Omega \sim \infty$	500 $\Omega \sim \infty$
C	∞	0	500 $\Omega \sim \infty$	500 $\Omega \sim \infty$
D	7.8 k $\Omega \sim \infty$	800 $\Omega \sim \infty$	800 $\Omega \sim \infty$	800 $\Omega \sim \infty$

NOTE

- Resistance value may vary with individual meters.

(With Charging Monitor type ... 5 Blades)

+	A	B	C	D	E	F
-	A	B	C	D	E	F
A	∞	∞	∞	19 $\Omega \sim 3 K \Omega$	3 K $\Omega \sim \infty$	3 K $\Omega \sim \infty$
B	∞	0	500 $\Omega \sim \infty$	∞	∞	∞
C	∞	0	500 $\Omega \sim \infty$	∞	∞	∞
D	7.5 K $\Omega \sim \infty$	925 $\Omega \sim \infty$	925 $\Omega \sim \infty$	10 K $\Omega \sim \infty$	10 K $\Omega \sim \infty$	10 K $\Omega \sim \infty$
E	330 $\Omega \sim 14 K \Omega$	∞	∞	∞	∞	1.2 K $\Omega \sim \infty$
F	14 k $\Omega \sim \infty$	∞	∞	∞	110 $\Omega \sim \infty$	110 $\Omega \sim \infty$

★ If the resistance is not as specified replace the regulator.

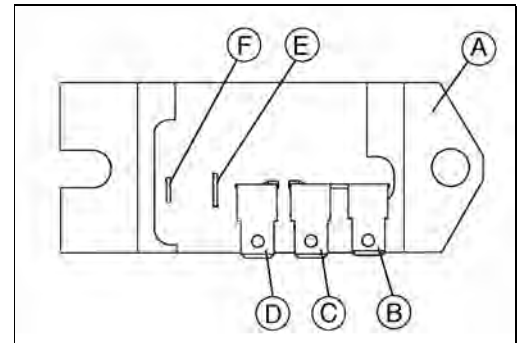
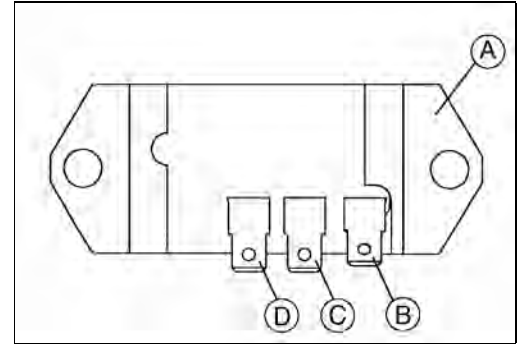

8-14 ELECTRICAL SYSTEM

Charging, Ignition System

This engine ignition is controlled by a solid state ignition assembly and requires no periodic maintenance except for the spark plugs.

The system consists of the following:

- Inductive Ignition Assemblies
- Permanent Magnet Flywheel
- Spark Plugs
- Stop Switch

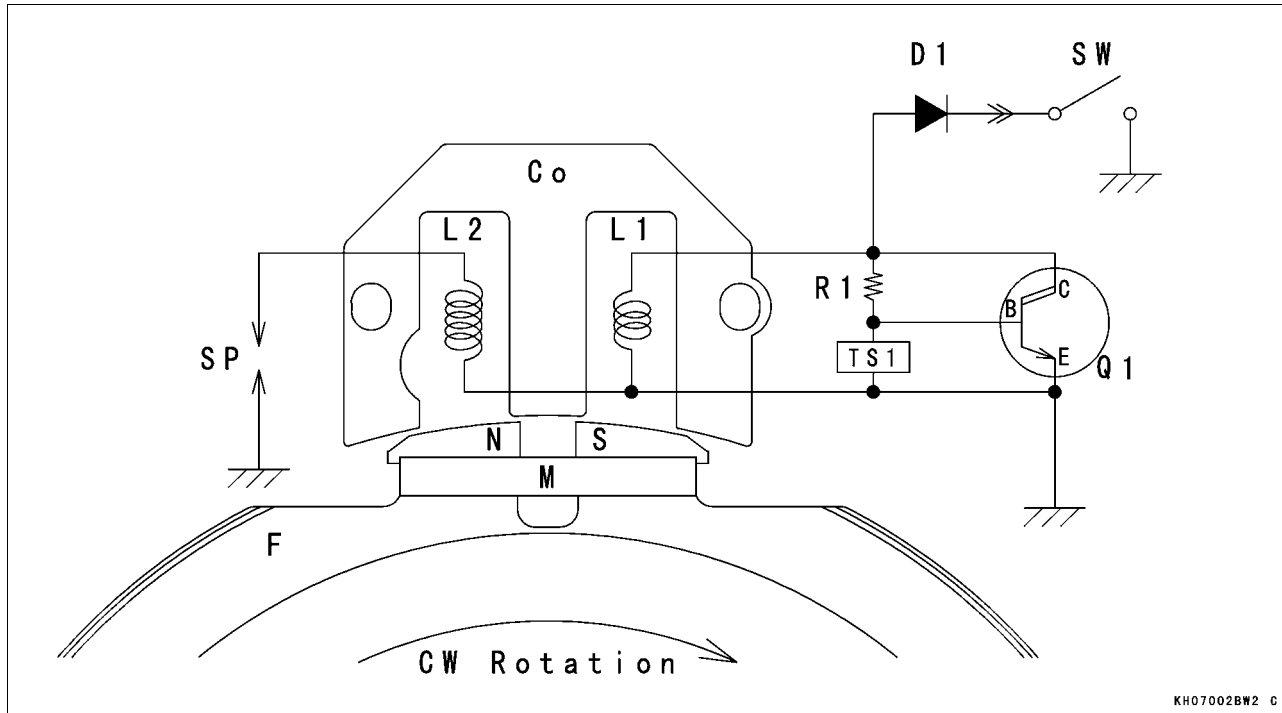

Co: Core (Lamination)
D1: Diode
L1: Primary Coil
L2: Secondary Coil
Q1: Transistor
B: Base
C: Collector
E: Emitter

R1: Control Resistor
TS1: Trigger Sensor
SP: Spark Plug
SW: Stop Switch
F: Flywheel
M: Magneto
N: North Pole
S: South Pole

Ignition Theory of Operation

Mounted to the periphery of a flywheel are a pair of magnetic poles (south leading in clockwise rotation), generated by a permanent magnet.

By rotating the flywheel (magnetic poles) clockwise past the ignition module on a laminated core group, a voltage is generated in the primary winding (L1).

This generates a small bias current to flow through the control resistor (R1) to the base of (Q1). This base drive causes the transistor to conduct (turns on) completing the primary circuit. Current flows from the high side of the primary winding through the transistor (collector to emitter) to ground.

The trigger sensor (TS1) senses the optimum time (peak current) to remove the base drive from the transistor (Q1). This abrupt "turning off" of the transistor causes an interruption in current flow which allows its associated flux collapse, and several hundred volts is induced through the primary winding (L1) inducing a very large voltage in the secondary winding (L2). When the secondary voltage reaches several thousand volts the spark plug (SP) gap is ionized and ignition occurs. The placement of the trigger sensor internal to the ignition insures constant timing over speed and temperature and prevents counterclockwise operation.

The diode (D1) in the ignition shut off circuit blocks inadvertent application of battery voltage, protecting the internal components of the ignition. With the stop switch (SW) in the closed position primary voltage is routed to ground, preventing ignition operation.

Charging, Ignition System

Ignition Coil Removal

- Remove:
 - Fan Housing (see Flywheel, Stator Coil Removal)
 - Spark Plug Cap [A]
 - Stop Switch Lead Connector [B]
 - Bolts [C]
 - Ignition Coil [D]

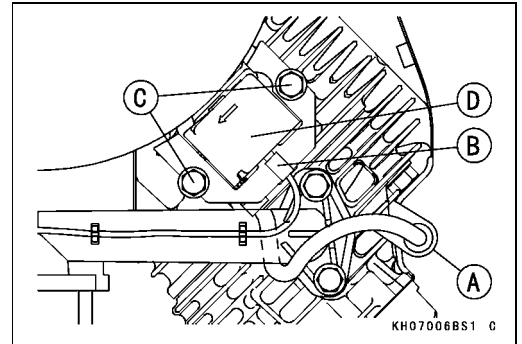

Ignition Coil Installation

- Install ignition coil on crankcase so that the stop switch lead connector [B] face the screen, and tighten bolt (1) first, then tighten bolt (2). While tightening bolts, adjust the air gap [A] between the three legs of ignition coil and the two pole-plates of magnet to the specified gap value as shown.

Ignition Coil Air Gap

Standard: 0.2 ~ 0.4 mm (0.008 ~ 0.016 in.)

- Torque - Ignition Coil Bolts (Stud Bolt)
7.8 N·m (0.80 kgf·m, 69 in·lb)
Ignition Coil Bolts (Flanged Bolt)
5.9 N·m (0.60 kgf·m, 52 in·lb)

NOTE

- Above procedure must be used to insure proper coil air gap is not too large.

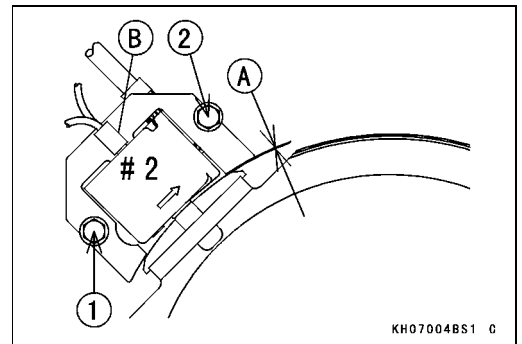
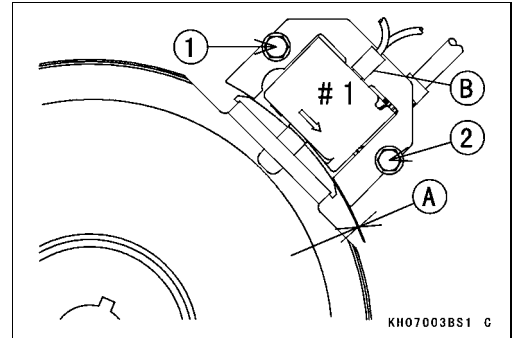

8-16 ELECTRICAL SYSTEM

Charging, Ignition System

Ignition Coil Inspection

- Remove the ignition coils (see Ignition Coil Removal).
- Measure the winding resistance as follows:
- Set the hand tester to the $R \times 1 \text{ k}\Omega$ range.

Special Tool - Hand Tester: 57001-1394

- Make the measurements shown in the table.

Ignition Coil Winding Resistance

	+	A	B	C
-				
A			2 ~ 18 k Ω	2 ~ 18 k Ω
B		∞		∞
C		2 ~ 18 k Ω	10 ~ 30 k Ω	

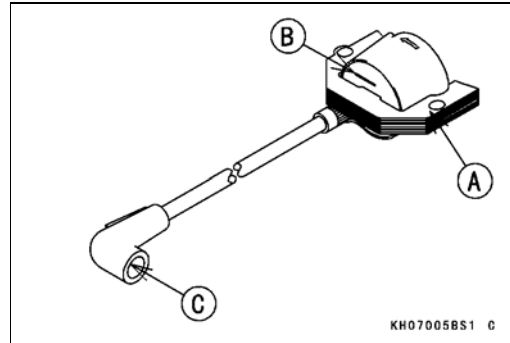

CAUTION

Use only Tester 57001-1394 with new battery at room temperature for this test. A tester other than the Hand Tester should show different readings.

If a megger or a meter with a large-capacity battery is used, the ignition coil will be damaged.

- ★ If the tester does not read as specified, replace the coil.

Spark Plug Removal

- Carefully pull the plug cap from the spark plug.
- Remove the spark plugs using a suitable plug wrench.

Spark Plug Installation

- Insert the spark plug vertically into the plug hole with the plug installed in the plug wrench.
- Tighten the plugs.

Torque - Spark Plugs: 22 N·m (2.2 kgf·m, 16 ft·lb)

- Fit the plug caps securely.
- Pull up the spark plug caps lightly to make sure of the installation of the spark plug caps.

Spark Plug Cleaning and Inspection

- Refer to Spark Plug Cleaning and Inspection in the Periodic Maintenance Chapter (2nd chapter).

Spark Plug Gap Inspection

- Refer to Spark Plug Gap Inspection in the Periodic Maintenance Chapter (2nd chapter).

Starter System

Starter Motor Removal

- Remove the mounting bolts [A] and pull the starter motor [B] from the engine.

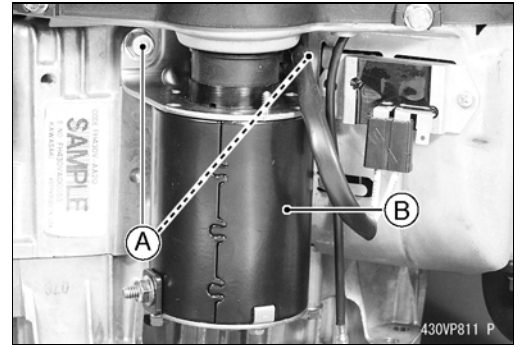

Starter Motor Installation

- Clean the starter motor and engine mounting flanges to ensure good electrical contact and tighten the mounting bolts.

Torque - Starter Motor Mounting Bolts: 15 N·m (1.5 kgf·m, 11.0 ft·lb)

Starter Motor Disassembly

- Remove:
 - Through Bolts [A]
 - Brush Plate [B]
 - Yoke [C]
 - Cap [D]

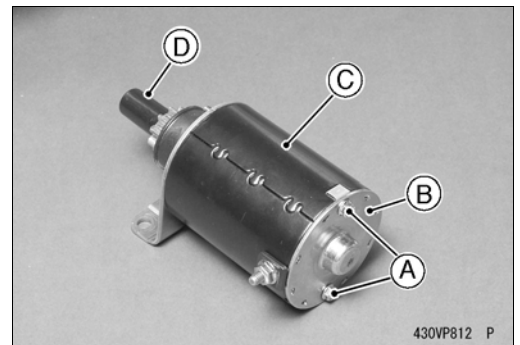

- Wrap a cloth around the Pinion assembly. Then, holding it on a vise with aluminum plates [A] placed in between and remove the nut.

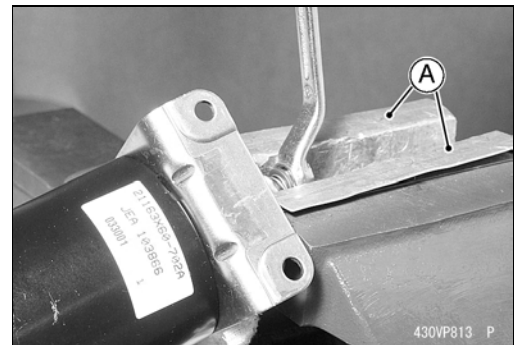

- Remove:
 - Washer [A]
 - Spring [B]
 - Collar [C]
 - Pinion Assembly [D]
 - Washer [E]
 - Slider [F]
 - Bracket [G]
 - Armature [H]
 - Washer [I]
 - Conical Spring Washer [J]

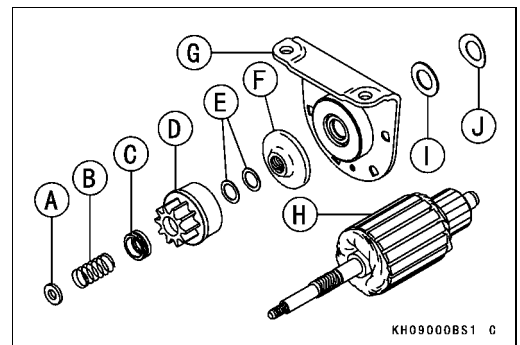

8-18 ELECTRICAL SYSTEM

Starter System

Starter Motor Assembly

- Assembly is the reverse of disassembly.
- Apply a small amount of grease to the armature shaft [A].

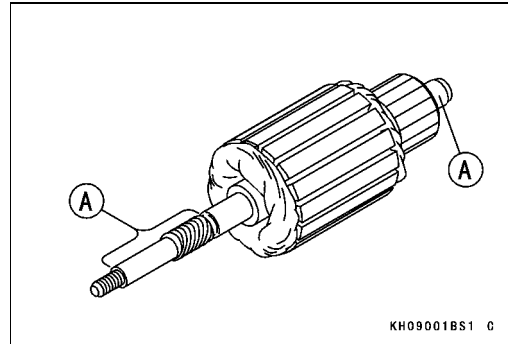

- Press the springs and holding the brush leads with suitable clips.
- Fit the brush assembly [A] into the armature [B].
- Fit the projection [C] on the brush assembly into the notch [D] in the yoke.
- Check the cap and replace it with a new one if damaged.

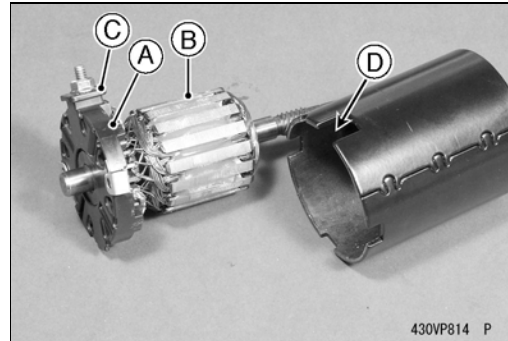

- Install the brush plate and tighten the through bolts as shown.
2° ~ 12° [A]
- Torque - Starter Motor Through Bolt: 3.9 N·m (0.40 kgf·m, 35 in·lb)

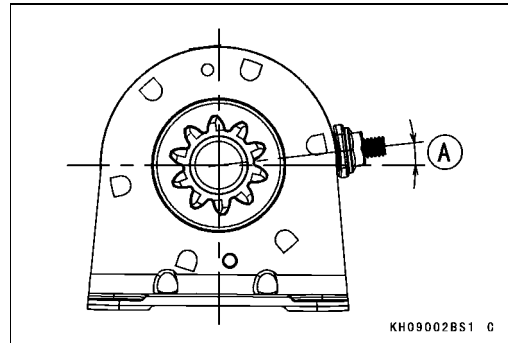

Starter Motor Brush Inspection

- Measure the overall length of each brush [A].
- ★ If the brushes are shorter than the service limit, replace them.

Brush Length	
Service Limit	4.0 mm (0.157 in.)

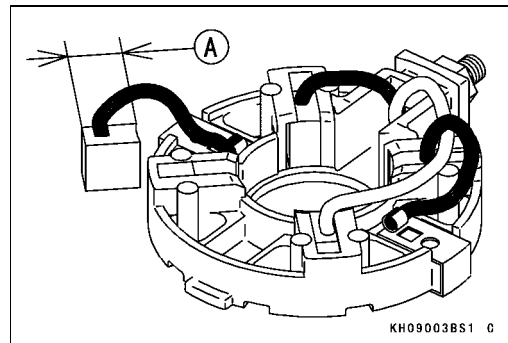

Brush Spring Inspection

- Inspect the brush springs for pitting, cracks, rusting and burrs.
- ★ Replace the spring if necessary.
- Inspect the springs for weakened conditions and distortion.
- ★ Replace the springs if necessary.
- ★ If the brush springs are able to press the brushes firmly into place, they may be considered serviceable. If they cannot, replace them.

Starter System

Armature Inspection

- Inspect the surface of the commutator [A].
- ★ If it is scratched or dirty, polish it with a piece of very fine emery cloth [B], and clean out the grooves.

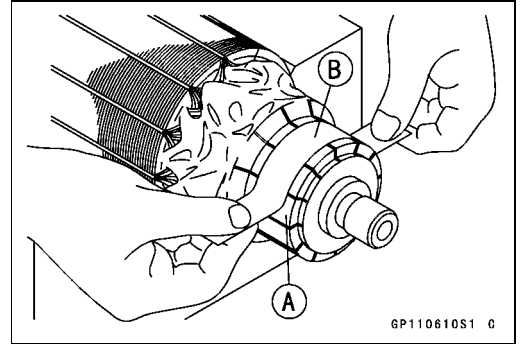

- Measure the depth of the grooves between the commutator segments.
- ★ If the grooves are shallower than the specified limit, replace the armature with a new one.
- ★ If the grooves are only dirty, clean them carefully.

Commutator Groove Depth Limit
Less than 1.0 mm (0.039 in.)

- [A] Bad
- [B] Segment
- [C] Good
- [D] 1.0 mm (0.039 in.) limit
- [E] Mica

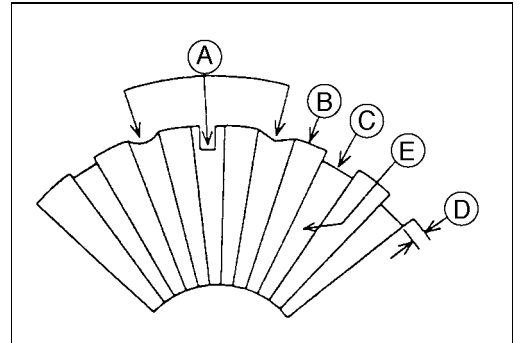

- Measure the commutator outside diameter [A] at several points.
- ★ If the diameter is less than the service limit, replace the armature with a new one.

Commutator Outside Diameter
Service Limit: 29.5 mm (1.161 in.)

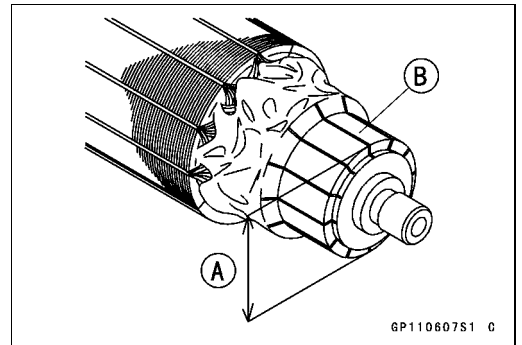

- Support the armature in an alignment jig at each end of the shaft as shown. Position a dial indicator perpendicular to the commutator.
- Rotate the armature slowly and read the commutator runout.
- ★ If runout is more than the service limit, turn down the commutator or replace the armature with a new one.

Commutator Runout
Service Limit: 0.0178 mm (0.0007 in.)

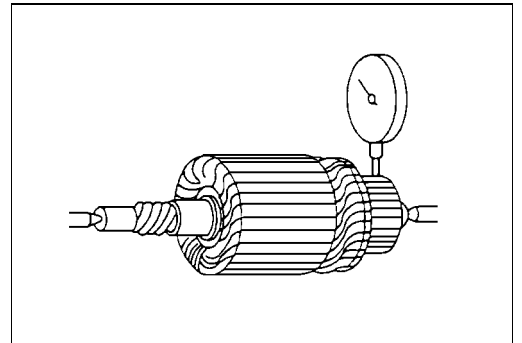

- Test the armature winding for shorts.
 - Place the armature on a growler [A].
 - Hold a thin metal strip (e.g., hack saw blade) on top of the armature.
 - Turn on the growler and rotate the armature one complete turn.
 - ★ If the metal strip vibrates, the windings are internally shorted to each other and the starter motor must be replaced.

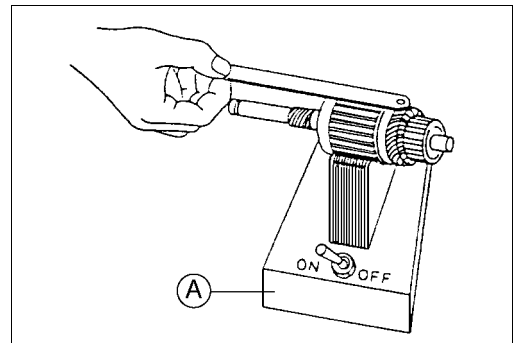

8-20 ELECTRICAL SYSTEM

Starter System

Pinion Clutch Inspection

- Turn the pinion gear by hand. The pinion gear should turn clockwise freely.
- ★ If the pinion clutch does not operate as it should, or if it makes noise, replace the pinion clutch.

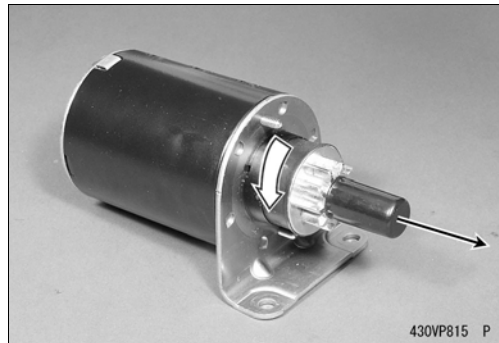

Recoil Starter Removal

- Remove:
 - Recoil Starter Mounting Nuts [A]
 - Recoil Starter [B]

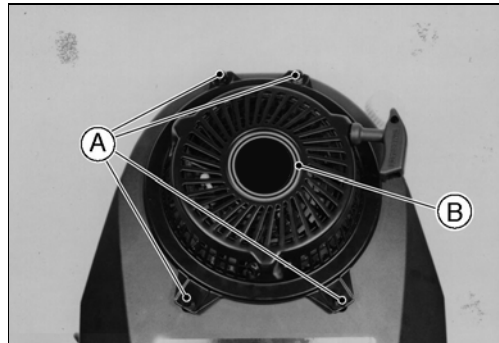

Recoil Starter Installation

- Install the recoil starter and tighten the mounting nuts.
Torque - Recoil Starter Mounting Nuts: 5.9 N·m (0.60 kgf·m, 52 in·lb)

Recoil Starter Disassembly

- Remove the recoil starter (see Recoil Starter Removal).
- Pull the handle [A] out 30 cm (1 ft), and clamp the rope [B] with the clip [C] so it can not wind back onto the reel [D].
- Pry the knot [E] out of the handle and untie it.
- Remove the handle from the rope.

⚠ WARNING

Wear gloves to avoid injury for the remaining steps.

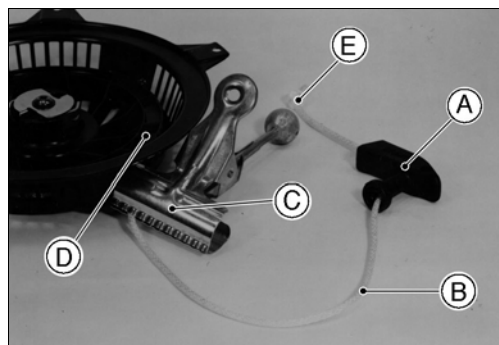

- While carefully holding the reel [A] and case [B], remove the clip.
- Unwind the spring tension slowly.

NOTE

- Do not wedge the rope between the reel and case.



Starter System

- Remove:
 - Screw [A]
 - Washer [B]
 - Retainer [C]
 - Center Spring [D]
 - Washer [E]
 - Pawls [F]
 - Return Springs [G]

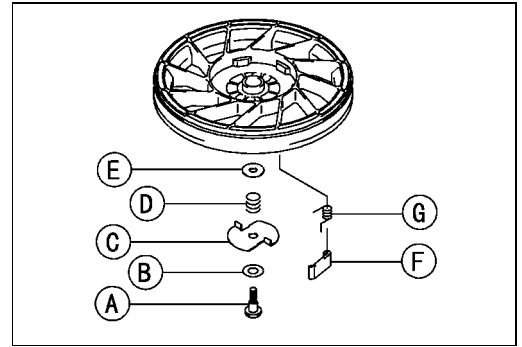

⚠ WARNING

When removing the reel [A], be careful that the recoil spring [B] under the reel does not fly loose and cause injury. The spring is under great pressure.

NOTE

- *There should be no spring tension on the reel when removing it. If tension is felt, push the reel back into place and gently "wiggle" it until the reel can be easily removed.*
- Slowly lift the reel straight up out of the case [C].

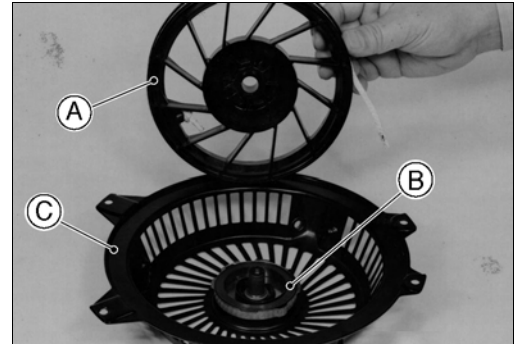

⚠ WARNING

If the recoil spring cassette is sticking with the reel, be careful that the cassette does not drop. Be careful that the recoil spring does not fly loose from the cassette and cause injury. The spring is under great pressure.

- Slowly lift the recoil spring cassette, straight up out of the case or reel.
- ★ If the recoil spring [A] must be removed from the cassette [B], hold the cassette with the opening side facing downward in a suitable container and tap the cassette to remove the recoil spring.

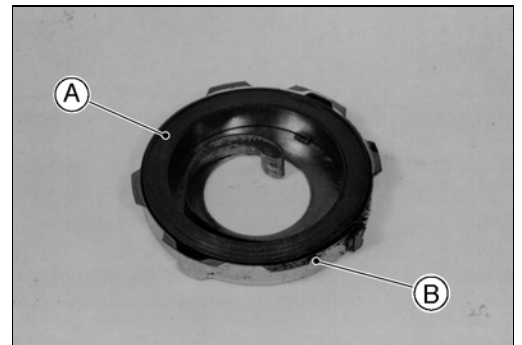

8-22 ELECTRICAL SYSTEM

Starter System

Recoil Starter Assembly

⚠ WARNING

Wear gloves during the recoil spring installation to avoid injury. The recoil spring must be assembled with great pressure.

- Lightly grease the recoil spring.
- Set the recoil spring into the spring cassette.
- Wind the rope clockwise [A] on the reel, and hold the rope end [B] with tape.
- Install the spring cassette [C] on the reel so that the tongues [D] on the cassette fit in the openings in the reel.

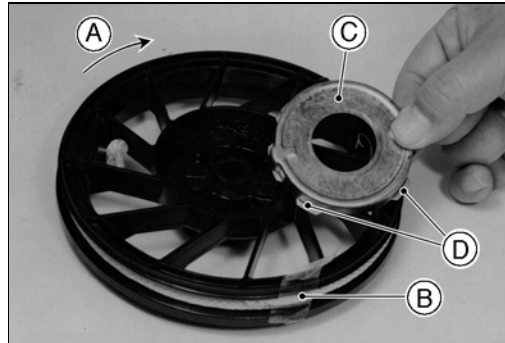

- Lightly grease the shaft [A].
- Put the reel into the case, with the round peg [B] aligned with the spring inner tongue [C].
- Turn the reel clockwise until you feel the hang hook on the catch.

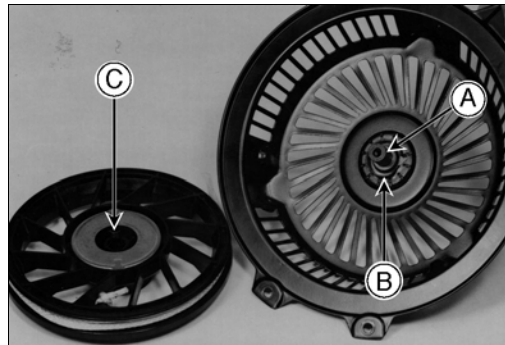

- Install:
 - Return Springs [A] and Pawls [B]
 - Washer [C] and Center Spring [D]
- Lightly grease the center spring.

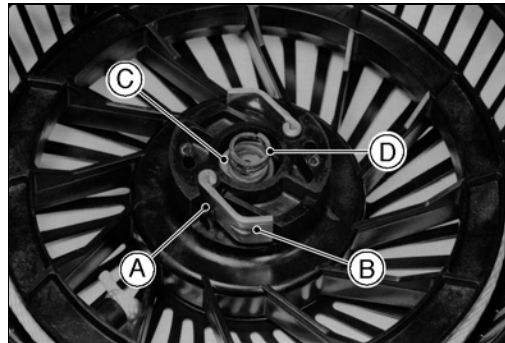

- Install:
 - Retainer [A]
 - Washer [B]
 - Screw [C]
- Turn the reel two turns counterclockwise to preload the recoil spring.

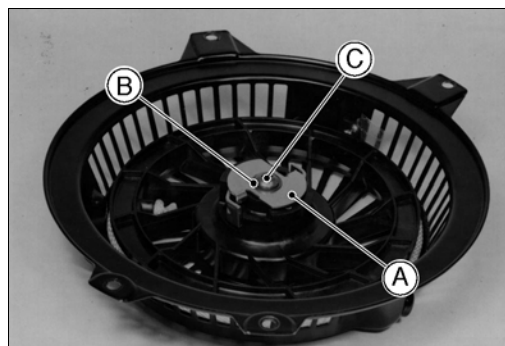

Starter System

- While holding the reel to keep it from unwinding, feed the end of the rope through the hole in the case.
- Clip the rope as shown to hold it.
- Install the handle [A], and secure it with a knot [B].
- Remove the clip [C] to release the rope.

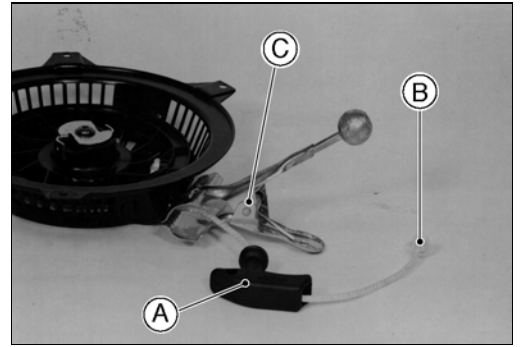

Troubleshooting

Table of Contents

Engine Troubleshooting Guide	9-2
Starter Motor Troubleshooting Guide.....	9-6

9-2 TROUBLESHOOTING

Engine Troubleshooting Guide

If the engine malfunctions, check if the way the engine is used is correct. If engine malfunctions even if engine is used correctly, systematically carry out troubleshooting starting with simple points.

This chart describes typical troubleshooting procedures.

Do not unnecessarily disassemble carburetor, magneto or engine unless it has been found to be the cause of malfunctioning.

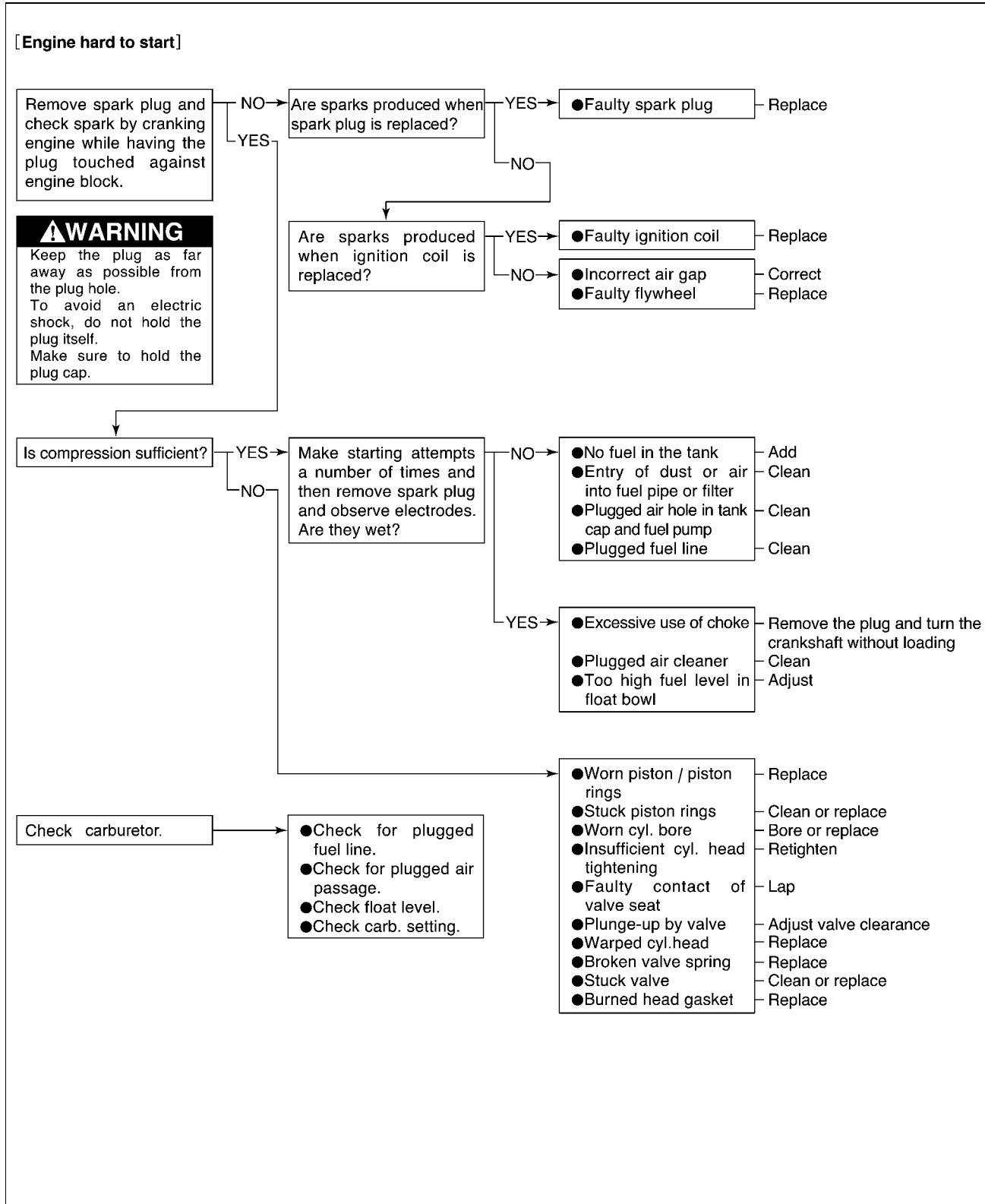

Engine Troubleshooting Guide

[Engine power loss]

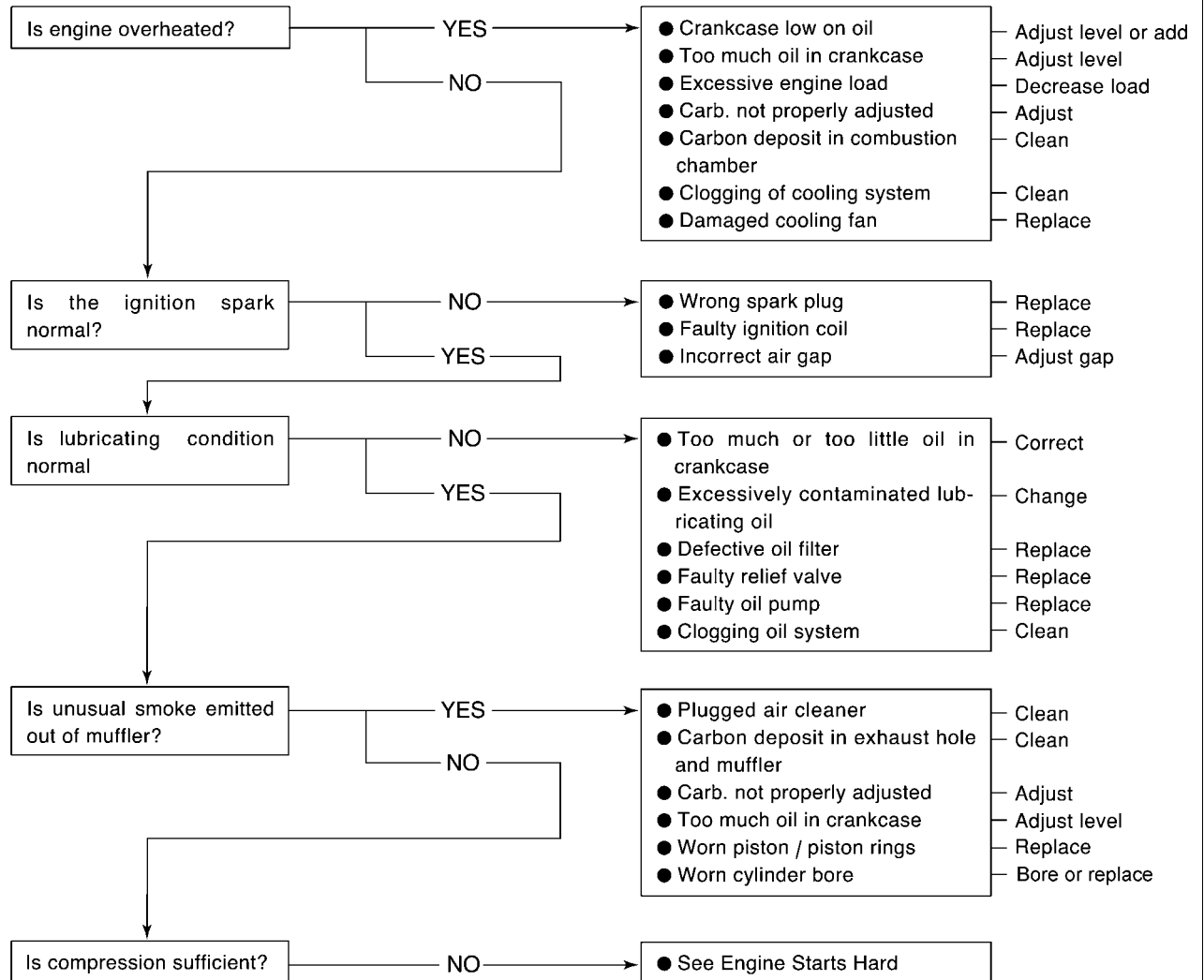

[Engine runs erratically]

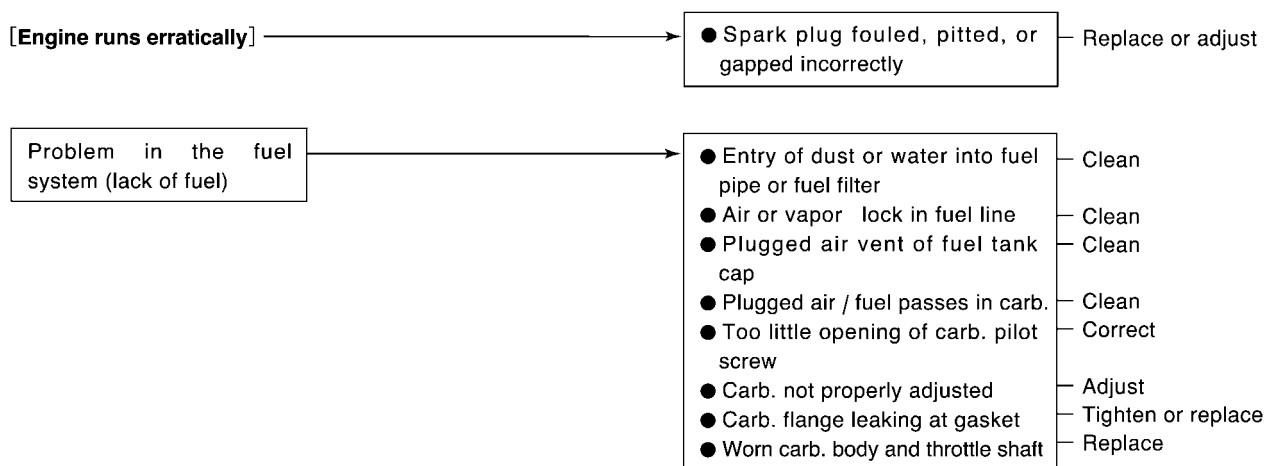

9-4 TROUBLESHOOTING

Engine Troubleshooting Guide

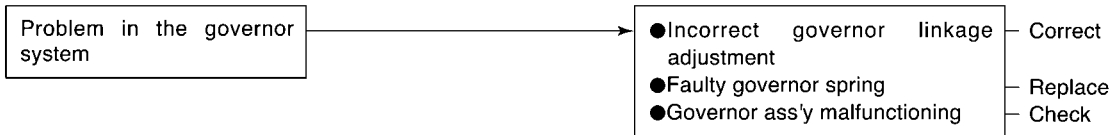

[Engine malfunctions at high speed]

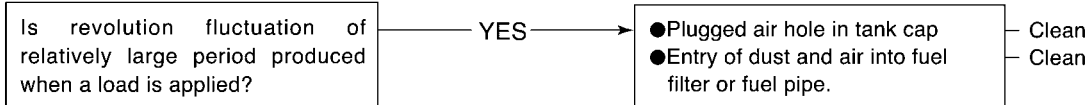

[Engine malfunctions at low speed]

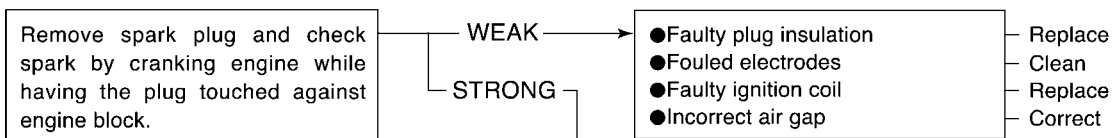

⚠ WARNING

Keep the plug as far away as possible from the plug hole. To avoid an electric shock, do not hold the plug itself. Make sure to hold the plug cap.

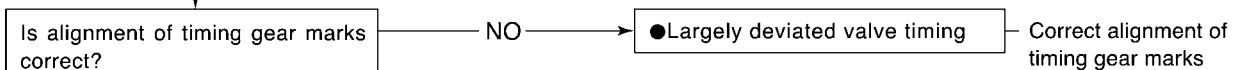
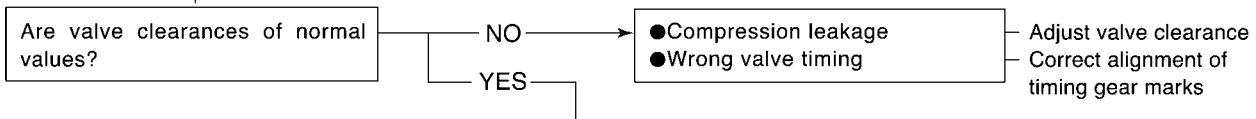
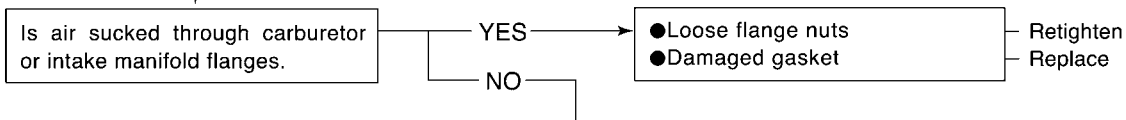
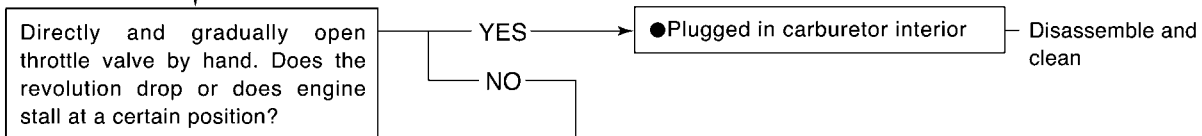
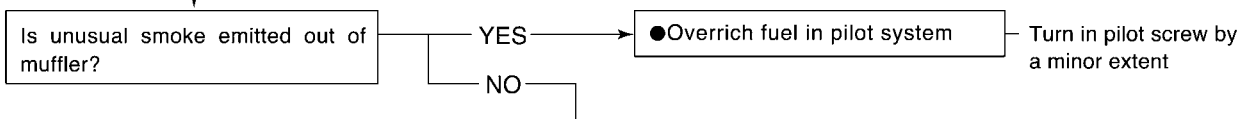

Engine Troubleshooting Guide

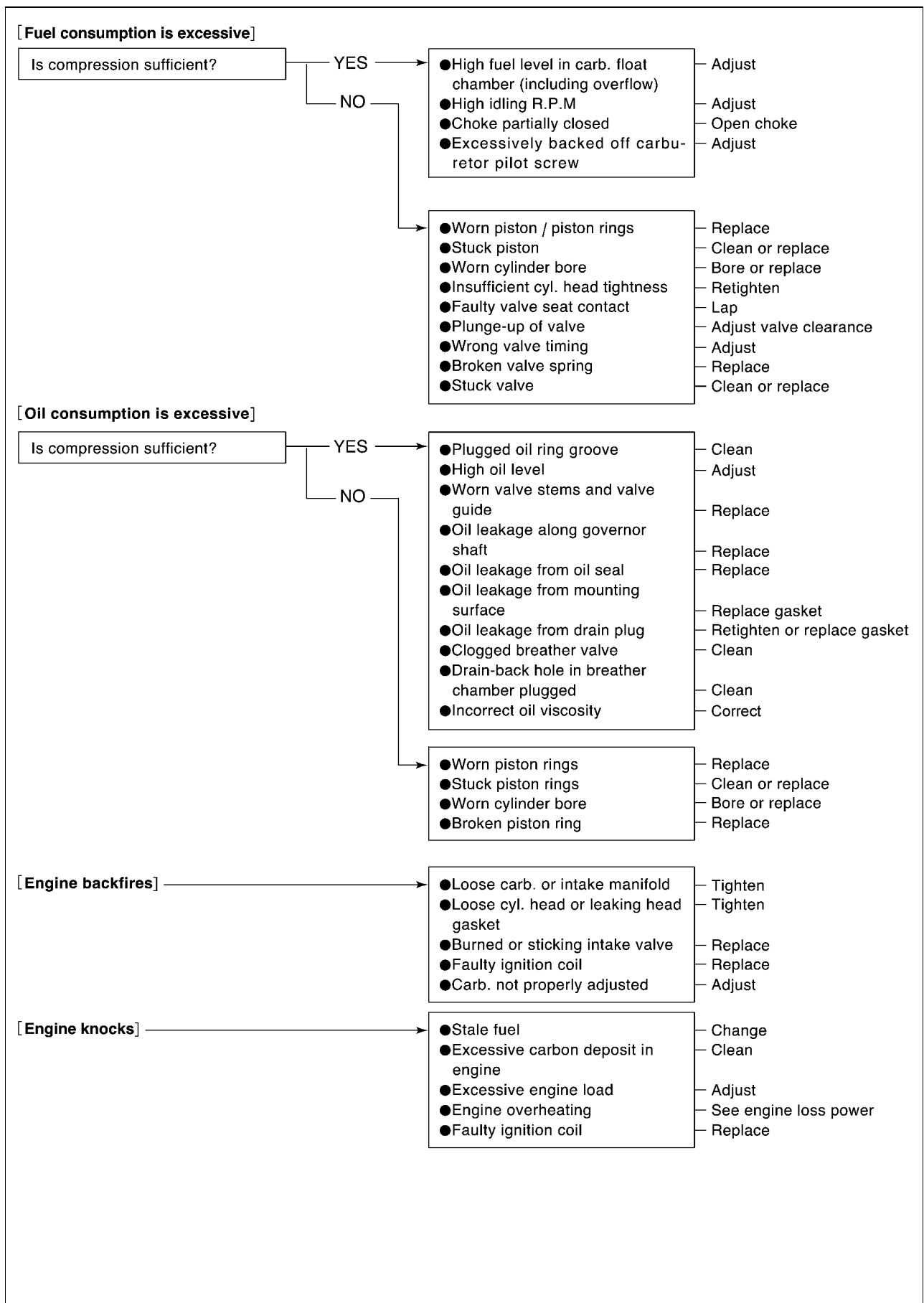

9-6 TROUBLESHOOTING

Starter Motor Troubleshooting Guide

1. Disconnect spark plug caps from the spark plugs.
2. Turn engine switch to "START" position and check condition.

⚠ WARNING

Engine may be cranked in this test. Do not touch any rotating parts of engine and equipment during test.

CAUTION

If starter does not stop by engine switch "OFF", disconnect negative (-) lead from battery as soon as possible.

[STARTER DOES NOT ROTATE]

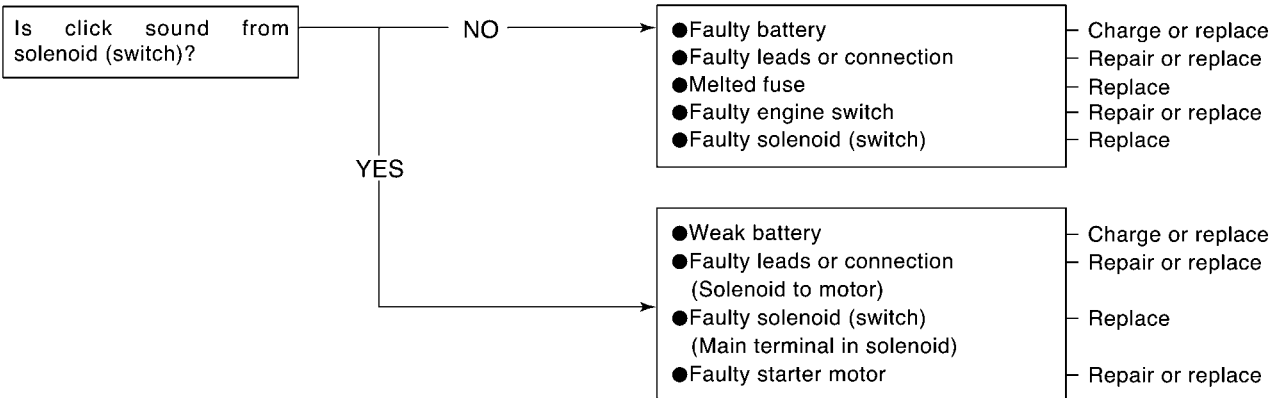

[STARTER ROTATES BUT SLOW]

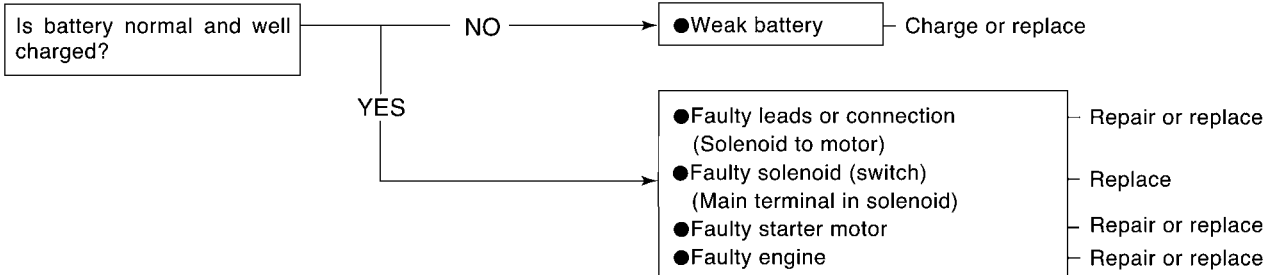

[STARTER ROTATES BUT CAN NOT CRANK ENGINE]

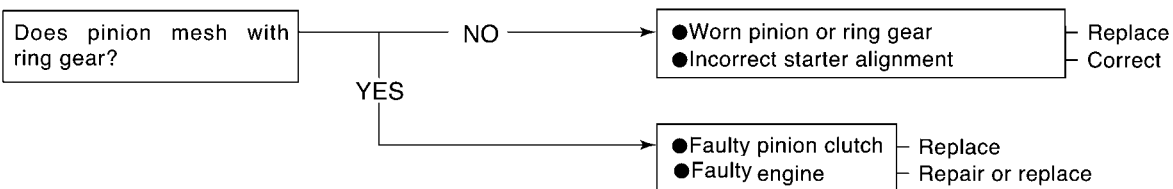

[STARTER DOES NOT STOP IN ENGINE SWITCH "OFF"]

