



Receiver Hitch Kit

for Workman HD/HDX/HDX-D Series Utility Vehicle

Model No. 117-4831

Installation Instructions

Safety

Safety and Instructional Decals



Safety decals and instructions are easily visible to the operator and are located near any area of potential danger. Replace any decal that is damaged or lost.

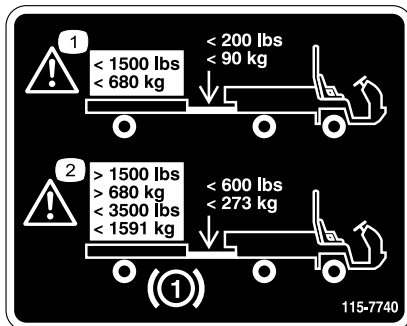

115-7740

1. Warning—maximum trailer weight is 1500 lb (680 kg), maximum tongue weight is 200 lb (90 kg).
2. Warning—trailer brakes are required when towing greater than 1500 lb (680 kg), maximum trailer weight with trailer brakes is 3500 lb (1591 kg), maximum tongue weight with trailer brakes is 600 lb (273 kg).

Installation

To use this kit, purchase and install a receiver hitch of your choice that does not exceed the specifications illustrated in Figure 1.

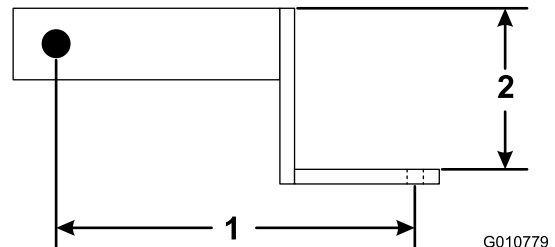

Figure 1

1. 10 inch (25.4 cm) maximum length
2. 6 inch (15.25 cm) maximum rise/8 inch (20.3 cm) maximum drop

Installing the Hitch

1. Stop the engine, set the parking brake, and remove the key from the ignition switch.
2. Remove the four bolts securing the hitch to the rear axle and remove the hitch. Save the bolts.
3. Install the receiver tube hitch on the rear axle using the four bolts removed previously (Figure 2). Torque the bolts to 35 to 40 ft-lb (47.5 to 54 N-m).

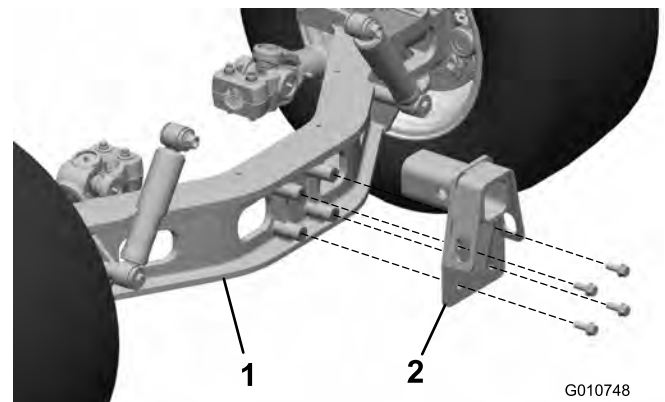

Figure 2

1. Rear axle
2. Receiver tube hitch