



Count on it.

Operator's Manual

1/3 Platform Lift

for Workman Heavy-Duty Utility Vehicle

Model No. 07344—Serial No. 2900000001 and Up

Introduction

Read this information carefully to learn how to operate and maintain your product properly and to avoid injury and product damage. You are responsible for operating the product properly and safely.

You may contact Toro directly at www.Toro.com for product and accessory information, help finding a dealer, or to register your product.

Whenever you need service, genuine Toro parts, or additional information, contact an Authorized Service Dealer or Toro Customer Service and have the model and serial numbers of your product ready.

This manual identifies potential hazards and has safety messages identified by the safety alert symbol (Figure 1), which signals a hazard that may cause serious injury or death if you do not follow the recommended precautions.



Figure 1

1. Safety alert symbol

This manual uses 2 other words to highlight information. **Important** calls attention to special mechanical information and **Note** emphasizes general information worthy of special attention.

Contents

Introduction.....	2
Safety.....	3
Before Operating	3
While Operating.....	3
Maintenance.....	3
Safety and Instructional Decals	4
Setup.....	6
1 Remove the Seat, Shroud and Fender	
Assemblies	7
2 Removing the Hood	7
3 Install the Main Wire Harness w/Relays.....	7
4 Mount the Parking Brake Switch.....	8
5 Mount Rear Level Switch	9
6 Mount Lift onto Vehicle Frame	10
7 Connect Wires	12
8 Reinstall Hood and Reconnect Battery.....	12
9 Mount Circular Bubble Level	12
10 Install Decals	12
Product Overview	14
Controls	14
Operation.....	15
Check Oil Level.....	15
Check Tire Pressure.....	15
Installing Safety Blocks	15
Operating the Lift.....	16
Operating Tips	18
Maintenance.....	20
Check Safety Circuits.....	20
Battery Care	20
Schematics	22

Safety

Before Operating

- Read and understand the contents of this manual before operating the platform lift. Become familiar with all controls and know how to stop quickly. A replacement manual is available at www.Toro.com.
- Do not allow children to operate the lift. Do not allow adults to operate it without proper instruction.
- Keep all shields and safety devices in place. If a safety device, shield or decal malfunctions, becomes damaged or illegible, replace it before operation is commenced. To assure lift is in safe operating condition, tighten loose nuts, bolts and screws.

While Operating

- Do not use near electrical power lines. Never allow platform lift to touch power lines.
- Do not use platform lift during lightning, thunderstorms, or high winds.
- Never move vehicle while platform is raised.
- Always apply parking brake before raising platform. Wheel chock use is recommended.
- Never release parking brake while platform is raised.
- Check safety interlocks before each use of platform. See operator's manual for safety interlock check instructions.
- Never bypass safety interlocks.
- Never allow riders on platform in any position.
- Always park vehicle on firm, level surface before raising platform.
- Never exceed 5 degree maximum angle of operation.
- Never raise platform if bubble level indicator is outside recommended operating range.
- Never raise platform if one or more vehicle tires are under inflated; check tire pressure daily.
- Never pull on objects while reaching from raised platform.
- Never use platform for carrying or lowering tree limbs, branches or heavy or uneven loads.
- Never exceed capacity of platform lift, one person with equipment not to exceed 600 lbs. (272 Kg).
- Always wear hard hat and eye protection while operating platform or while in area below platform.
- Never drop or throw articles from raised platform.

- When raising platform be alert for overhead obstructions which could cause eye, head or crushing injuries.
- Stand clear of scissor arms while platform is moving.
- Make sure area is clear of bystanders before lowering platform.

Maintenance

- Always remove key from lift control box when platform is not in use.
- Ensure lift is in safe operating condition. Keep nuts, bolts and screws tight.
- Never work under raised platform without lift safety blocks installed.
- To be sure of optimum performance and safety, always purchase genuine Toro replacement parts and accessories. Replacement parts and accessories made by other manufacturers could be dangerous. Such use could void the product warranty of The Toro® Company.

Safety and Instructional Decals



Safety decals and instructions are easily visible to the operator and are located near any area of potential danger. Replace any decal that is damaged or lost.

⚠ DANGER





CONTACT BETWEEN NON-INSULATED PLATFORM LIFT AND POWER LINES WILL CAUSE ELECTROCUTION. ELECTROCUTION WILL CAUSE SERIOUS PERSONAL INJURY OR DEATH.

⚡ NEVER USE PLATFORM LIFT NEAR POWER LINES.

⚡ NEVER ALLOW PLATFORM LIFT TO TOUCH POWER LINES.

⚡ IF POWER LINE CONTACT OCCURS:

- LOWER UNIT AWAY FROM CONTACT IF POSSIBLE.
- DO NOT TOUCH POWER LINE.
- NEVER TOUCH GROUND WHILE TOUCHING PLATFORM LIFT OR POWER LINE.
- JUMP CLEAR IF NECESSARY, WITHOUT TOUCHING PLATFORM OR POWER LINE.

⚡ IF OPERATING PLATFORM LIFT NEAR ELECTRICAL, HIGH PRESSURE OF ANY TYPE OR ROTATING EQUIPMENT:

- ALWAYS DISCONNECT POWER TO THAT EQUIPMENT.
- ALWAYS USE OSHA APPROVED LOCK-OUT DEVICES.

⚡ NEVER USE PLATFORM LIFT DURING A THUNDER OR LIGHTNING STORM.

93-3702

93-3702

⚠ DANGER

IMPROPER OPERATION OF PLATFORM LIFT MAY CAUSE SERIOUS PERSONAL INJURY OR DEATH. TO REDUCE RISK TO OPERATOR AND BYSTANDERS:

⚡ READ AND UNDERSTAND ALL SAFETY INSTRUCTIONS IN WORKMAN AND PLATFORM LIFT OPERATOR'S MANUALS AND WARNING LABELS.

⚡ NEVER USE PLATFORM LIFT WITHOUT PROPER TRAINING AND AUTHORIZATION.

⚡ ESTA MAQUINA PUEDE SER RIESGOSA SI SE USA EN UNA MANERA INAPROPIADA. OPERADORES DEBEN ESTAR MUY BIEN ENTRENADOS EN LA MANERA PROPIA DE OPERAR LA MAQUINA.

FOR REPLACEMENT MANUAL, SEND COMPLETE MODEL AND SERIAL NUMBER TO:

THE TORO COMPANY
8111 LYNDALE AVE. S.
BLOOMINGTON, MN 55420-1196

93-3701

93-3701

⚠ WARNING

OPERATION OF PLATFORM LIFT WITHOUT PARKING BRAKE ENGAGED CAN RESULT IN TIP-OVER AND PERSONAL INJURY.

⚡ ALWAYS APPLY PARKING BRAKE BEFORE OPERATING PLATFORM LIFT. THE USE OF WHEEL CHOCKS IS RECOMMENDED.

⚡ DO NOT RELEASE PARKING BRAKE WHILE PLATFORM LIFT IS RAISED.

⚡ DO NOT RAISE THE PLATFORM LIFT IF THE BUBBLE IS OUTSIDE OF THE OPERATING REGION OF THE LEVEL INDICATOR. 93-3710

93-3710

⚠ DANGER





LOSS OF CONTROL OR TIP-OVER WILL RESULT IF VEHICLE IS MOVED WITH PLATFORM IN RAISED POSITION AND MAY CAUSE SERIOUS PERSONAL INJURY TO OPERATOR OR BYSTANDERS.

⚡ NEVER MOVE VEHICLE WHILE PLATFORM IS RAISED.

⚡ ALWAYS APPLY PARKING BRAKE BEFORE RAISING PLATFORM. WHEEL CHOCK USE IS RECOMMENDED.

⚡ NEVER RELEASE PARKING BRAKE WHILE PLATFORM IS RAISED.

⚡ CHECK SAFETY INTERLOCKS BEFORE EACH USE OF PLATFORM. SEE OPERATOR'S MANUAL FOR SAFETY INTERLOCK CHECK INSTRUCTIONS.

⚡ NEVER BYPASS SAFETY INTERLOCKS.

⚡ NEVER ALLOW RIDERS ON PLATFORM IN ANY POSITION.

93-3703

93-3703

IMPORTANT

EMERGENCY LOWERING PRECAUTIONS:

⚡ REACH INTO THE ACCESS OPENING ONLY TO ACTIVATE THE EMERGENCY LOWERING VALVE.

⚡ PUSH AND TURN THE RED KNOB ON THE SOLENOID TO ACTIVATE EMERGENCY LOWERING VALVE.

⚡ DO NOT PLACE HANDS OR FEET ON SCISSORS ARMS OR OTHER SUPPORTING STRUCTURE WHILE THE PLATFORM LIFT IS COMING DOWN.

⚡ IF OPERATOR IS STRANDED UP IN THE LIFT, MAKE EVERY ATTEMPT POSSIBLE TO ALERT SOMEONE TO ASSIST IN ACTIVATING THE EMERGENCY LOWERING VALVE.

⚡ USE EXTREME CAUTION IF YOU MUST CLIMB DOWN FROM THE DISABLED LIFT.

93-3711

93-3711

⚠ DANGER

TIP-OVER OF WORKMAN VEHICLE WHILE PLATFORM IS RAISED WILL RESULT IN PERSONAL INJURY TO OPERATOR AND/OR BYSTANDERS.

- ⚠ ALWAYS PARK VEHICLE ON FIRM, LEVEL SURFACE BEFORE RAISING PLATFORM.
- ⚠ NEVER EXCEED 5 DEGREE MAXIMUM ANGLE OF OPERATION.
- ⚠ NEVER RAISE PLATFORM IF BUBBLE LEVEL INDICATOR IS OUTSIDE RECOMMENDED OPERATING RANGE.
- ⚠ NEVER RAISE PLATFORM IF ONE OR MORE VEHICLE TIRES ARE UNDERINFLATED; CHECK TIRE PRESSURE DAILY.
- ⚠ NEVER PULL ON OBJECTS WHILE REACHING FROM RAISED PLATFORM.
- ⚠ NEVER USE PLATFORM FOR CARRYING OR LOWERING TREE LIMBS, BRANCHES OR HEAVY OR UNEVEN LOADS.
- ⚠ NEVER EXCEED CAPACITY OF PLATFORM LIFT (ONE PERSON WITH EQUIPMENT NOT TO EXCEED 600 LBS/272 KG.)
- ⚠ NEVER RAISE PLATFORM DURING HIGH WINDS OR THREATENING WEATHER.
- ⚠ NEVER BY-PASS SAFETY INTERLOCKS.
- ⚠ NEVER ALLOW RIDERS ON PLATFORM IN ANY POSITION.

93-3704

93-3704

⚠ DANGER

CONTACT WITH MOVING SCISSOR ARMS CAN CAUSE PERSONAL INJURY.

- ⚠ STAND CLEAR OF SCISSOR ARMS WHILE PLATFORM IS MOVING.
- ⚠ MAKE SURE AREA IS CLEAR OF BYSTANDERS BEFORE LOWERING PLATFORM.
- ⚠ NEVER WORK UNDER RAISED PLATFORM WITHOUT LIFT SAFETY BLOCK INSTALLED.
- ⚠ ALWAYS REMOVE KEY FROM LIFT CONTROL BOX WHEN PLATFORM IS NOT IN USE.

93-3706

93-3706



93-3709

⚠ DANGER

PLATFORM LIFT CAN CRUSH & CAUSE PERSONAL INJURY.

- ⚠ NEVER WORK UNDER RAISED PLATFORM WITHOUT LIFT SAFETY BLOCKS INSTALLED.

93-3708

93-3708

⚠ DANGER

FALLING OBJECTS AND OVERHEAD OBSTRUCTIONS CAN CAUSE PERSONAL INJURY.

- ⚠ ALWAYS WEAR HARD HAT AND EYE PROTECTION WHILE OPERATING PLATFORM OR WHILE IN AREA BELOW PLATFORM.
- ⚠ KEEP BYSTANDERS AWAY FROM AREA BELOW RAISED PLATFORM WHILE OVERHEAD WORK IS PERFORMED.
- ⚠ NEVER DROP OR THROW ARTICLES FROM RAISED PLATFORM.
- ⚠ WHEN RAISING PLATFORM BE ALERT FOR OVERHEAD OBSTRUCTIONS WHICH COULD CAUSE EYE, HEAD OR CRUSHING INJURIES.

93-3705

93-3705

⚠ DANGER

FALLING OR JUMPING FROM RAISED PLATFORM WILL CAUSE PERSONAL INJURY.

- ⚠ SECURE BOTH HANDRAIL SNAP CHAINS ACROSS OPENING BEFORE RAISING PLATFORM.
- ⚠ NEVER PULL ON OBJECTS WHILE REACHING FROM RAISED PLATFORM.
- ⚠ NEVER REACH OVER HANDRAILS UNLESS BOTH FEET ARE ON PLATFORM DECK.
- ⚠ NEVER STEP ABOVE LEVEL OF PLATFORM DECK OR USE LADDERS, STEP RISERS OR PLATFORM RAILS TO EXTEND WORKING HEIGHT OF PLATFORM.
- ⚠ IF YOU MUST EXIT RAISED PLATFORM, SLOWLY AND CAREFULLY CLIMB DOWN OUTSIDE OF SCISSOR ARM FRAME.

93-3707

93-3707

Setup

Loose Parts

Use the chart below to verify that all parts have been shipped.

Procedure	Description	Qty.	Use
1	No parts required	–	Remove the seat, shroud and fender assemblies
2	No parts required	–	Remove the hood
3	Main Wire Harness w/ Relays Cable Tie Screw, 1/4 x 3/4 inch Nut, 1/4 inch Fuse	1 7 2 2 1	Install main wire harness w/relays
4	Parking brake switch Screws	1 2	Mount the Parking Brake Switch
5	Rear level switch bracket Rear level switch w/ harness	1 1	Mount rear level switch
6	Reinforcing Plate Spacer tube Flange HD. Capscrew, 3/8-16 x 3 inch Flange HD. Capscrew, 3/8-16 x 3–1/2 inch Flange HD. Capscrew, 3/8-16 x 1 inch Flangenut, 3/8-16	2 2 2 2 4 4	Mount lift onto vehicle frame
7	No parts required	–	Connect wires
8	No parts required	–	Reinstall hood and reconnect battery
9	Circular Bubble Level	1	Mount circular bubble level
10	Operation Decal No Step Decal	1 2	Install decals

The 1/3 platform lift is designed to be used only with a Workman Vehicle and must be mounted with the wiring harness, level, decals, switches and all interlock switches installed. The 1/3 platform lift will only work on Workman 3000–4000 series vehicles with serial numbers 240000001 and up and all Workman HD, HDX and HDX-D vehicles.

1

Remove the Seat, Shroud and Fender Assemblies

No Parts Required

Procedure

1. Position vehicle on a clean, level surface, stop engine, engage parking brake and remove key from ignition switch. Disconnect positive cable from battery.
2. Unscrew and remove all knobs from console levers and from the gear shift lever (Figure 2).

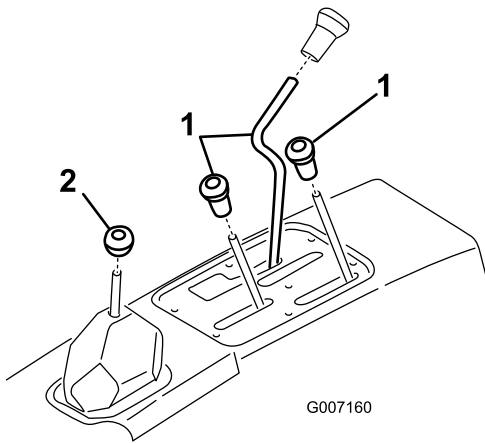

Figure 2

1. Console levers
2. Gear shift lever

3. Remove (6) screws securing outside edge of center console cover plate to frame and remove cover plate (Figure 3).
4. Disconnect the reservoir hose from the radiator and plug or clamp it to retain coolant (Figure 3). Remove the operator shield from the ROPS.

Pressurized hot coolant escaping can cause serious burns.

Allow engine to cool enough to touch before removing overflow tube or radiator cap.

5. Remove the capscrews securing the seats and shroud to mounting brackets (Figure 3). Remove the seats and shroud.

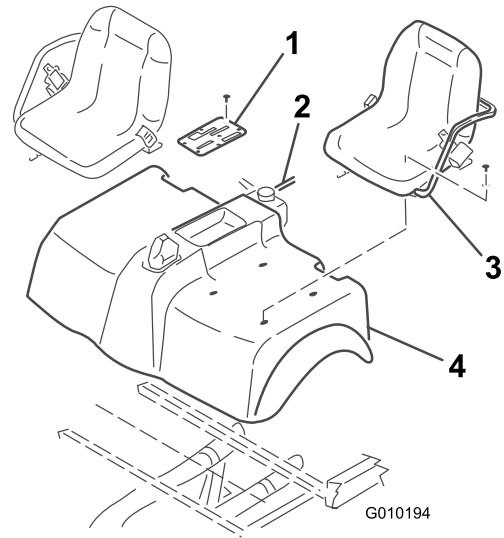

Figure 3

- | | |
|------------------------|-----------|
| 1. Console cover plate | 3. Seat |
| 2. Reservoir hose | 4. Shroud |

2

Removing the Hood

No Parts Required

For Workman 3000–4000 series vehicles with serial numbers 240000001 and up

1. Remove the (6) screws and nuts securing the bumper to the vehicle frame and remove the bumper.
2. Remove the (7) screws securing the front hood to the vehicle frame and remove the hood.

For Workman HD, HDX and HDX-D vehicles

1. Position the vehicle on a level surface, stop the engine, engage the parking brake and remove the key from the ignition.
2. While grasping the hood in the headlight openings, lift up on the hood to release the lower mounting tabs from the bumper slots.
3. Pivot the bottom of the hood upward until the top mounting tabs can be pulled from the dash slots.
4. Pivot the top of the hood forward and unplug the wire connectors from the head lights.
5. Remove the hood.

3

Install the Main Wire Harness w/Relays

Parts needed for this procedure:

1	Main Wire Harness w/ Relays
7	Cable Tie
2	Screw, 1/4 x 3/4 inch
2	Nut, 1/4 inch
1	Fuse

For Workman 3000–4000 series vehicles with serial numbers 240000001 and up

1. Insert end of wire harness, with male and female spade terminals on it, up through opening in vehicle floor board, toward dash panel, following vehicle wire harness. Secure harness to vehicle wire harness with (2) cable ties.
2. Locate red/black wire connected to "I" terminal of ignition switch. Remove wire from "I" terminal and plug into appropriate wire harness terminal. Plug remaining harness terminal onto ignition switch "I" terminal.
3. Remove fasteners securing wire harness cover to under side of vehicle floor and remove cover.
4. Route wire harness rearward to console area. Harness must not interfere with any hot (exhaust) or moving parts. Secure the harness with cable ties.
5. Mount the relays to the left frame channel with 2 (1/4 x 3/4 inch) screws and (1/4 inch) nuts (Figure 4).

Note: If the vehicle is equipped with high flow hydraulics, locate another suitable mounting location.

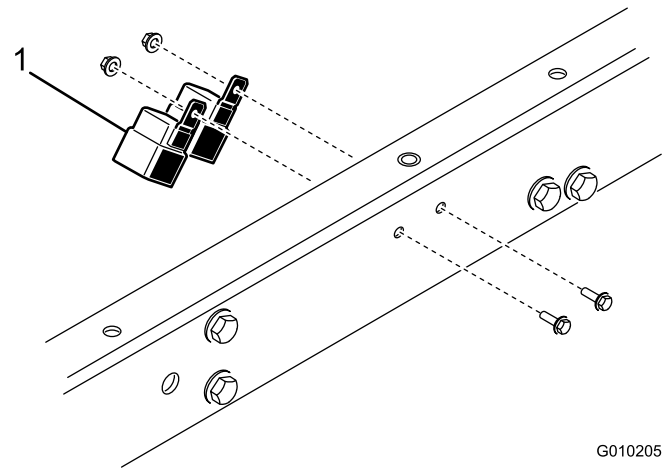

G010205

Figure 4

1. Relays

For Workman HD, HDX and HDX-D vehicles

1. Insert end of wire harness, with male and female spade terminals on it, up through opening in vehicle floor board.
2. Locate an empty slot in the fuse block. If no empty slot is available, an additional fuse block (Toro part no. 92–2641) will have to be added.
3. Insert the included fuse into the empty fuse block slot and connect the wire harness spade terminal to the corresponding spade terminal on the fuse block.
4. Remove fasteners securing wire harness cover to under side of vehicle floor and remove cover.
5. Route wire harness rearward to console area. Harness must not interfere with any hot (exhaust) or moving parts. Secure the harness with cable ties.
6. Mount the relays to the left frame channel with 2 (1/4 x 3/4 inch) screws and (1/4 inch) nuts (Figure 4).

Note: If the vehicle is equipped with high flow hydraulics, locate another suitable mounting location.

4

Mount the Parking Brake Switch

Parts needed for this procedure:

1	Parking brake switch
2	Screws

Procedure

1. Mount the parking brake switch to the parking brake mount with two screws as shown in Figure 5.

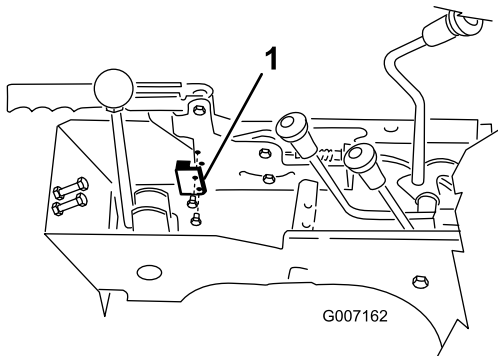

Figure 5

1. Switch

2. Plug switch wire connector into lift wire connector harness.
3. Remove the loop back connector from the vehicle wire harness labeled 1/3 lift. Connect the lift wire harness to the vehicle wire harness.

5

Mount Rear Level Switch

Parts needed for this procedure:

1	Rear level switch bracket
1	Rear level switch w/ harness

For Workman 3000–4000 series vehicles with serial numbers 24000001 and up

1. Remove locknuts securing hitch plate to rear axle (Figure 6). Using the upper set of mounting holes,

loosely mount the level switch bracket to rear axle with locknuts removed.

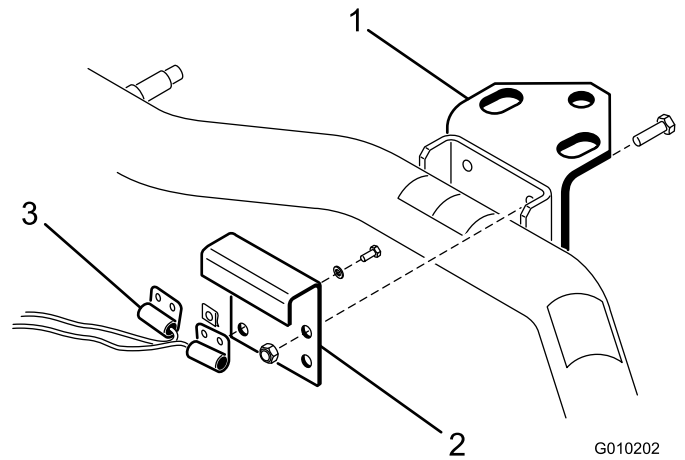

Figure 6

1. Hitch plate
2. Level switch bracket
3. Switch harness

2. Route switch harness forward, along differential lock cable to left side of machine. Harness must not interfere with any hot (exhaust) or moving parts. Secure harness to differential lock cable with cable ties.

For Workman HD, HDX and HDX-D vehicles

1. Remove capscrews securing hitch plate to rear axle (Figure 7). Using the lower set of mounting holes, loosely mount 2 washers and level switch bracket to rear axle with capscrews removed. The washers are to be positioned between the hitch plate and axle.

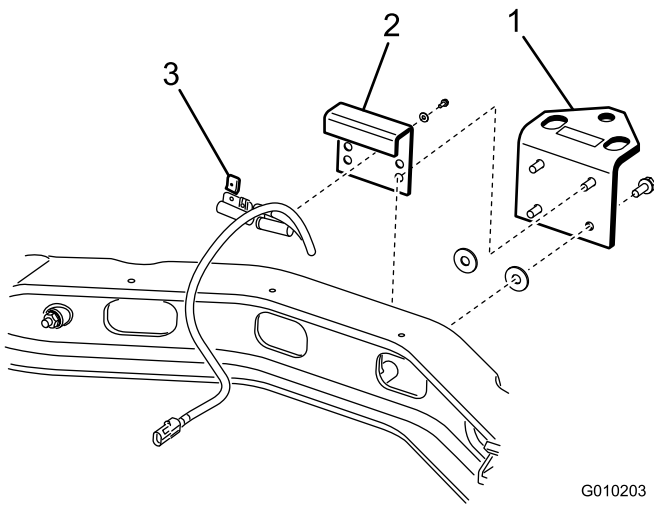

Figure 7

- 1. Hitch plate
- 2. Level switch bracket
- 3. Switch harness

2. Route switch harness forward, along shift cable to left side of machine. Harness must not interfere with any hot (exhaust) or moving parts. Secure harness to shift cable with cable ties.

6

Mount Lift onto Vehicle Frame

Parts needed for this procedure:

2	Reinforcing Plate
2	Spacer tube
2	Flange HD. Capscrew, 3/8-16 x 3 inch
2	Flange HD. Capscrew, 3/8-16 x 3-1/2 inch
4	Flange HD. Capscrew, 3/8-16 x 1 inch
4	Flangenut, 3/8-16

For Workman 3000–4000 series vehicles with serial numbers 240000001 and up

Note: To install the platform lift in the mid position, the Mid Mount Kit for the Platform Lift, Part No. 93-3741 must be purchased and installed.

1. Remove any accessories mounted to top of frame in forward position such as a 1/3 bed, power platform, H.D. Hitch Frame extension tubes (Figure 8), etc.

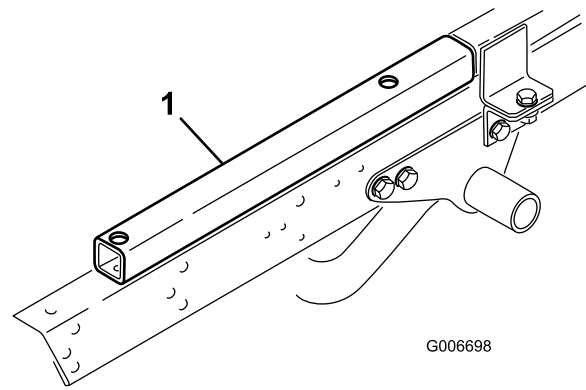

Figure 8

1. Hitch frame extension tube

2. Locate and remove the threaded insert from the mounting hole in left and right vehicle frame channels, as shown in Figure 9.

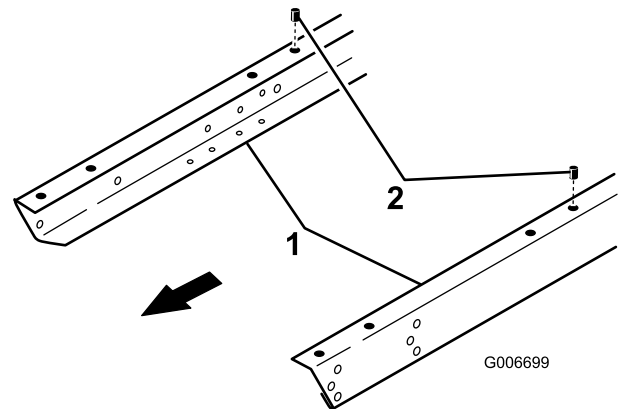

Figure 9

1. Vehicle frame channel
2. Threaded insert

Note: To prevent lift scissor arms from expanding, pick up the platform lift from the bottom when positioning on frame.

3. Position lift onto frame aligning mounting holes with holes in frame (Figure 10).

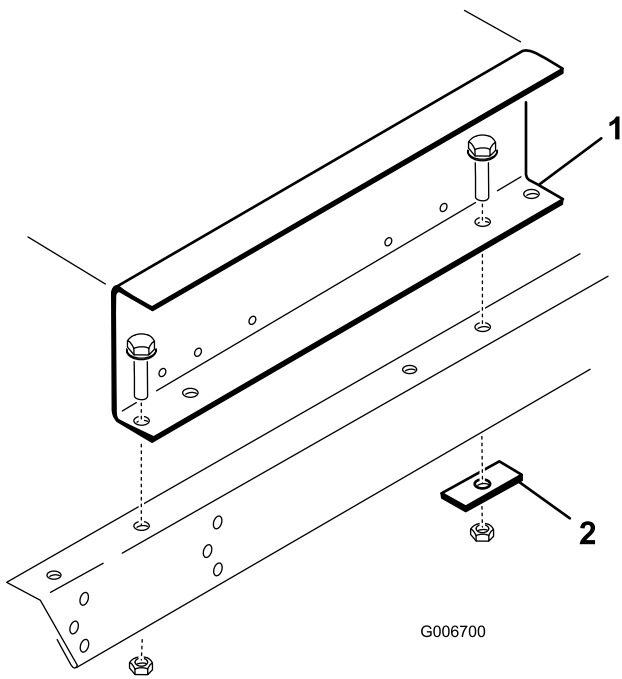

Figure 10

1. Lift
2. Reinforcing plate

4. Mount each side of lift to frame channels with a reinforcing plate and (2) 3/8-16 x 1 inch large flange head capscrews and flange nuts (Figure 10). Reinforcing plates to be used in rear mounting holes only.

For Workman HD, HDX and HDX-D vehicles

Note: To install the platform lift in the mid position, the Mid Mount Kit for the Platform Lift, Part No. 93-3741 must be purchased and installed.

1. Remove any accessories mounted to top of frame in forward position such as a 1/3 bed, power platform, H.D. Hitch Frame extension tubes, etc. (Figure 8),

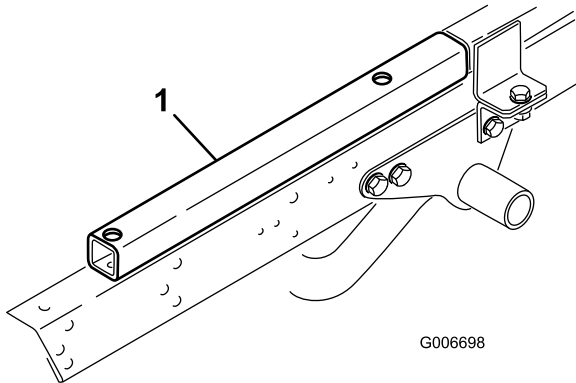

Figure 11

1. Hitch frame extension tube

2. Locate and remove the threaded insert from the mounting hole in left and right vehicle frame channels, as shown in Figure 9.

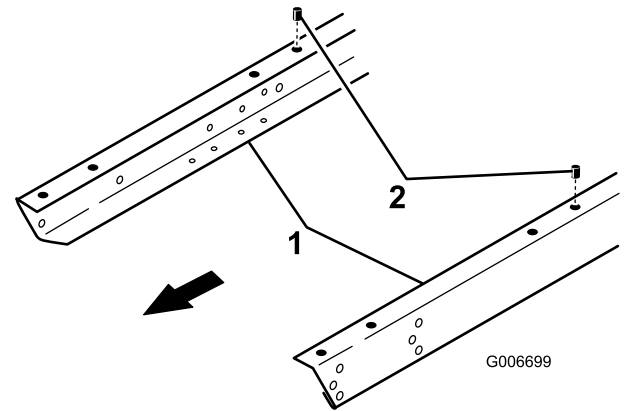

Figure 12

1. Vehicle frame channel
2. Threaded insert

3. Position a spacer tube onto each frame channel aligning mounting holes with holes in frame (Figure 13).

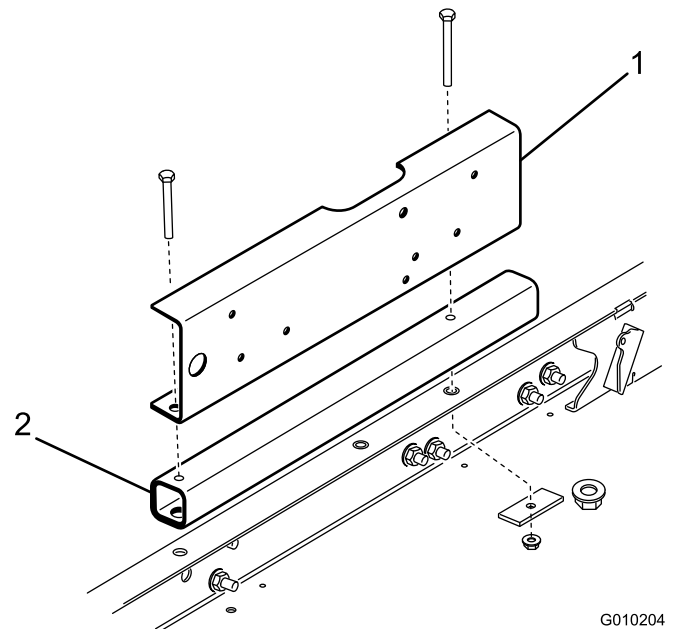

Figure 13

1. Spacer tube
2. Lift
3. Reinforcing plate

Note: To prevent lift scissor arms from expanding, pick up the platform lift from the bottom when positioning on frame.

4. Position lift onto spacer tubes aligning mounting holes with holes in tubes (Figure 13).
5. Mount the rear of each side of lift to the frame channels with a reinforcing plate, (2) 3/8-16 x 3-1/2

inch flange head capscrews and flange nuts. Use the (2) 3/8-16 x 3 inch flange head capscrews in front mounting holes (Figure 13).

7

Connect Wires

No Parts Required

Procedure

1. Plug rear harness into connector from front harness.
2. Plug the connector from the lift into the lift harness.
3. Connect ground wire from lift to engine ground.
4. Remove nut from positive battery clamp, insert positive wire from lift onto cable clamp screw and loosely secure with nut.

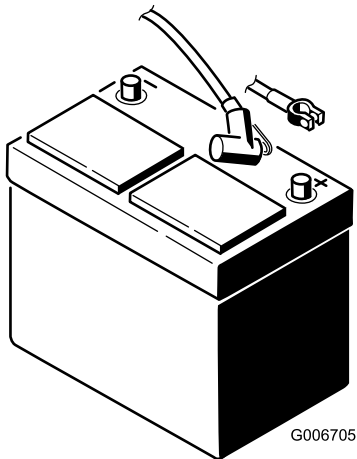

Figure 14

1. Positive lift wire
2. Positive battery cable clamp

5. Make sure wiring is clear of all hot or rotating parts. Secure with cable ties as required.

8

Reinstall Hood and Reconnect Battery

No Parts Required

Procedure

1. Reinstall hood to frame.

2. Reinstall shroud, seats, seat frame and console cover plate, if applicable.
3. Reinstall overflow tube to radiator. Check coolant level and replenish, if required.
4. Reinstall positive battery cable to battery.
5. Slide rubber boot over positive terminal to prevent possible short-out from occurring.

9

Mount Circular Bubble Level

Parts needed for this procedure:

1	Circular Bubble Level
---	-----------------------

Procedure

Affix circular level to top of console cover positioning as shown in Figure 15.

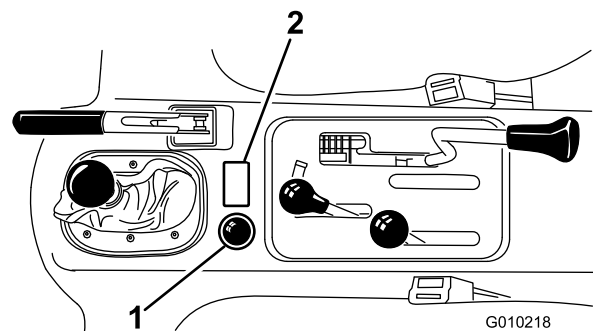

Figure 15

1. Circular level
2. Operation decal

10

Install Decals

Parts needed for this procedure:

1	Operation Decal
2	No Step Decal

For Workman 3000–4000 series vehicles with serial numbers 240000001 and up

1. Affix operation decal to top of console cover positioning as shown in Figure 15.
2. Affix a "No Step" decal to top of each fuel tank mounting strap, as shown in Figure 16.

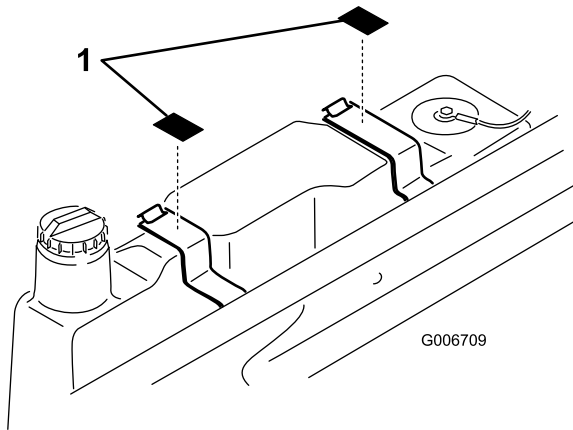

Figure 16

1. No—Step decal

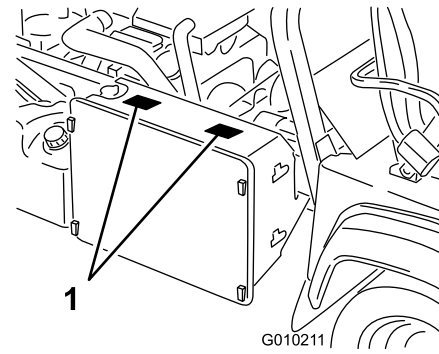

Figure 17

1. No—Step decal

For Workman HD, HDX and HDX-D vehicles

1. Affix operation decal to top of console cover positioning as shown in Figure 15.
2. Affix the "No Step" decals to top of radiator, as shown in Figure 17.

Product Overview

Controls

Up Button

Press "UP" button to raise lift (Figure 18).

Down Button

Press "DOWN" button to lower lift (Figure 18).

Key Switch

Rotate key switch to authorize use of lift. Remove key from lift pendant control switch to prevent operation when unattended. (Figure 18).

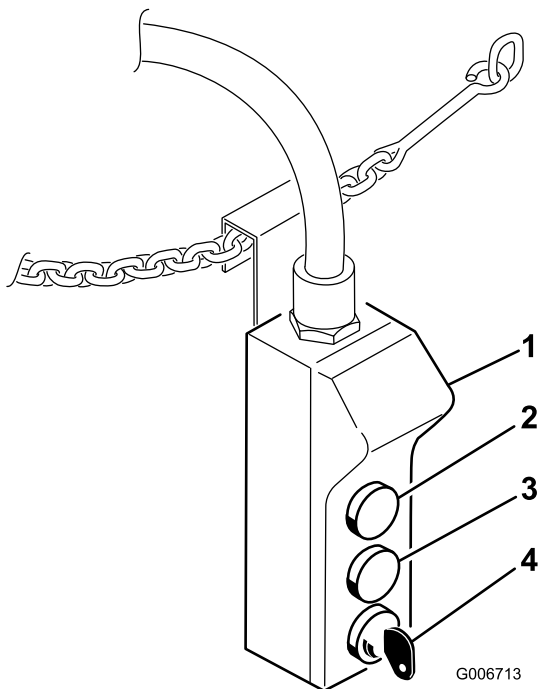

Figure 18

- | | |
|--------------------|----------------|
| 1. Pendant control | 3. DOWN button |
| 2. UP button | 4. Key switch |

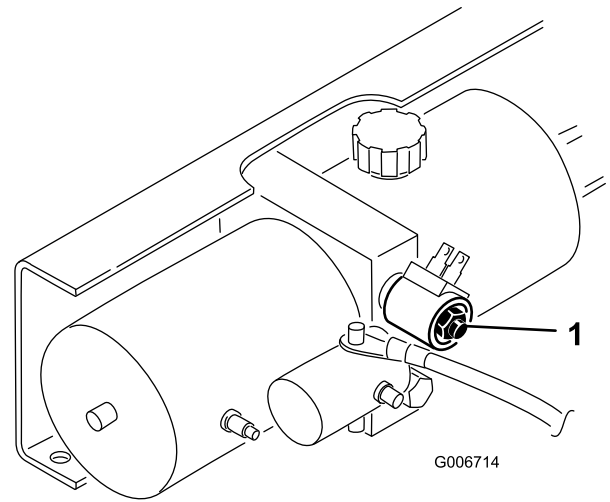

Figure 19

1. Emergency lowering valve knob

Emergency Lowering Valve Knob

Push in red knob on solenoid valve and rotate 180 degrees counter-clockwise to activate emergency lowering valve. To stop lift and return to normal operation, push button in, rotate 180 degrees clockwise and release (Figure 19).

Operation

Check Oil Level

The lift reservoir is filled at the factory with DTE 13 hydraulic oil. Check level before lift is first operated and every 8 hours or daily, thereafter. Capacity of system is 1.5 qt.

1. Position the vehicle on a level surface.
2. Raise lift and install safety blocks. Refer to the Installing Safety Blocks section and the Operation chapter.

Note: If lift cannot be raised, due to lack of oil in reservoir, it may be raised with a hoist and safety blocks installed, to expose reservoir breather cap.

3. Clean area around reservoir breather cap (Figure 20).

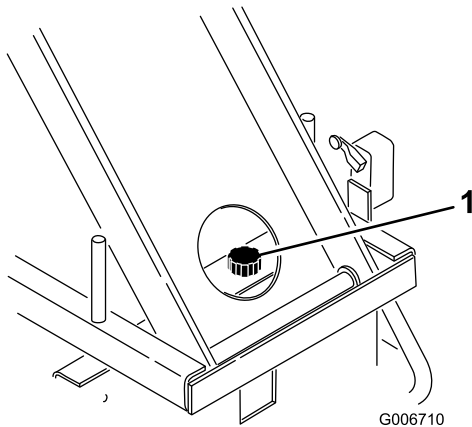

Figure 20

1. Reservoir cap

4. Unscrew breather cap from top of reservoir.
5. Insert a clean rod or stick into reservoir and check fluid level. Fluid should be within 2 inches from top of reservoir. If level is low, add enough DTE 13 hydraulic oil to achieve the proper level. **DO NOT OVERFILL.**

Note: If DTE 13 hydraulic oil is not available, DTE 24 or Dextron II ATF may be substituted. Fluids may be mixed, after initial fill of reservoir.

Note: Always use DTE 13, DTE 24, or equivalent ISO Viscosity Grade 32 oils when reservoir must be completely refilled or if cold weather is expected. The use of other fluids may inhibit the operation of the lift.

Check Tire Pressure

Check tire pressure every 8 hours or daily to assure proper levels.

Refer to the vehicle operator's manual for proper tire inflation specification.

Installing Safety Blocks

1. Position the vehicle on a level surface.
2. Set parking brake and chock wheels.
3. Rotate vehicle key switch to "Off" position.
4. While standing next to machine, grasp pendant control and rotate lift key switch to "On" position. Check overhead clearance and for any obstructions.
5. Press "UP" button to raise lift high enough to install safety blocks. Stand clear of scissor arms while platform is moving.



Contact with moving scissor arms can cause personal injury.

- Stand clear of scissor arms while platform is moving.
- Make sure area is clear of bystanders before lowering platform.
- Never work under raised platform without lift safety blocks installed.
- Always remove key from lift control box when platform is not in use.

6. Remove retaining pins securing safety blocks to side of lift frame (Figure 21).

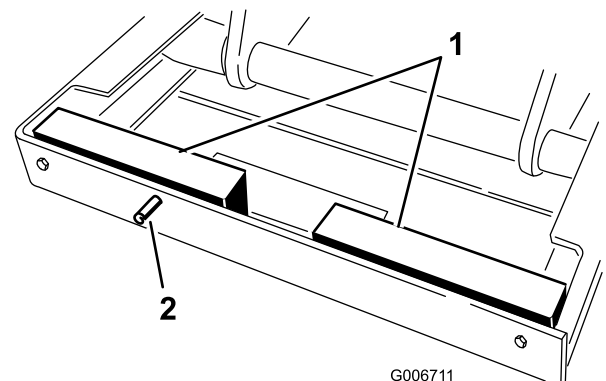

Figure 21

1. Safety block
2. Retaining pin

7. Rotate safety blocks 90 degrees in channel and secure to ends of lift frame with retaining pins (Figure 22).

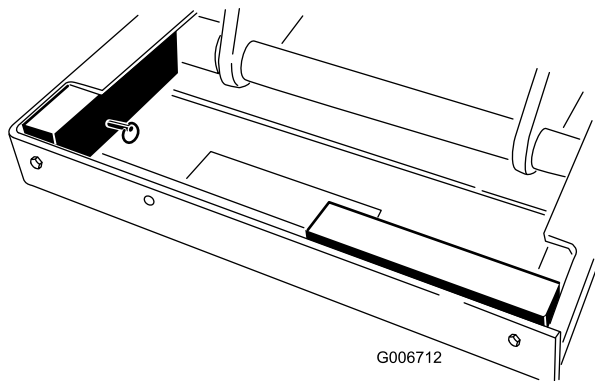

Figure 22

⚠

Improper operation of platform lift may cause serious personal injury or death. To reduce risk to operator and bystanders:

- **Read and understand all safety instructions in Workman and Platform Lift Operator's Manuals and warning labels.**
- **Never use a platform lift without proper training and authorization.**

The electrical control system of the lift requires the vehicle to be parked on a slope of less than a 5 degree angle, parking brake engaged and the vehicle key in the "Off" position in order to activate the lift circuit.

Operating

1. Set parking brake and chock wheels.
2. Rotate vehicle key switch to "Off" position.
3. Climb into platform and secure safety chains across entry (Figure 23).

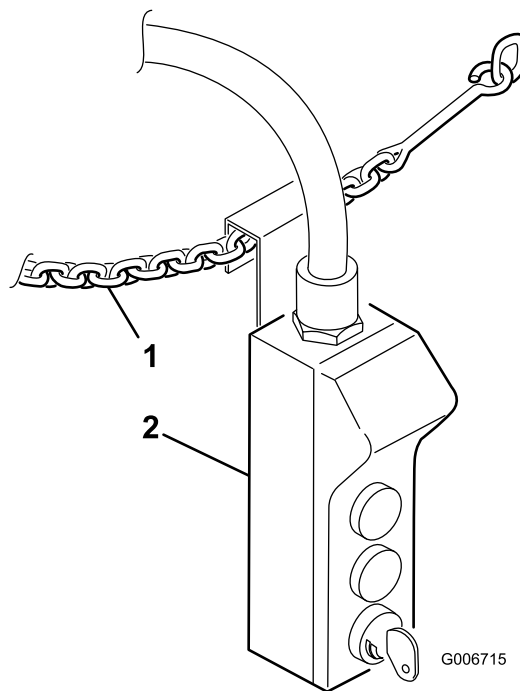

Figure 23

1. Safety chain
2. Pendant control

4. Grasp pendant control and rotate lift key switch to "On" position.
5. Press "UP" button to raise lift; "DOWN" button to lower lift.

⚠

Platform lift can crush and cause personal injury.

- **Never work under raised platform without lift safety blocks installed.**
- **Never use safety blocks to support a load on lift.**

8. Press "DOWN" button on pendant control and lower lift until rollers gently contact safety blocks.
9. To remove safety blocks:
 - Raise lift slightly.
 - Remove retaining pins.
 - Return safety blocks to storage position.
 - Secure with retaining pins.

Operating the Lift

The 1/3 platform lift is designed to be used only with a Workman Vehicle and must be mounted with the wiring harness, level, decals, switches and all interlock switches installed.



Operation of platform lift without parking brake engaged can result in tip-over and personal injury.

- Always apply parking brake before operating platform lift. The use of wheel chocks is recommended.
- Do not release parking brake while platform lift is raised.
- Do not raise the platform lift if the bubble is outside of the operating region on the level indicator.



Loss of control or tip-over will result if vehicle is moved with platform in raised position and may cause serious personal injury to operator or bystanders.

- Never move vehicle while platform is raised.
- Always apply parking brake before raising platform. Wheel chock use is recommended.
- Never release parking brake while platform is raised.
- Check safety interlocks before each use of platform. See operator's manual for safety interlock check instructions.
- Never bypass safety interlocks.
- Never allow riders on platform in any position.

If lift does not operate:

- Make sure vehicle key and lift key are in "Off" position.
 - Make sure vehicle is parked on less than a 5 degree angle slope.
 - Make sure vehicle parking brake is "On".
6. When finished with work operation, lower lift all the way down to stops and remove key from lift pendant control to prevent operation when unattended.

Important: If engine kills when releasing parking brake, it may indicate that lift is not completely lowered. Vehicle can not be driven with lift raised at any height.



Contact between non-insulated platform lift and power lines will cause electrocution.

- Electrocution will cause serious personal injury or death.
 - Never use platform lift near power lines.
 - Never allow platform lift to touch power lines.
 - If power line contact occurs:
 - Lower unit away from contact if possible.
 - Do not touch power line.
 - Never touch ground while touching platform lift or power line.
 - Jump clear if necessary, without touching platform lift or power line.
 - If operating platform lift near electrical, high pressure or any type of rotating equipment:
 - Always disconnect power to that equipment.
 - Always use OSHA approved lock-out devices.
 - Never use the platform lift during a thunder or lightning storm.
- Lower the platform lift and avoid open areas in the event of threatening weather.

Emergency Lowering

1. Reach into access opening only to activate emergency lowering valve.
2. Push in red knob on solenoid valve (Figure 24) and rotate 180 degrees counter-clockwise to activate emergency lowering valve.



Contact with moving scissor arms can cause personal injury.

- Stand clear of scissor arms while platform is moving.
- Make sure area is clear of bystanders before lowering platform.
- Never work under raised platform without lift safety blocks installed.
- Always remove key from lift control box when platform is not in use.

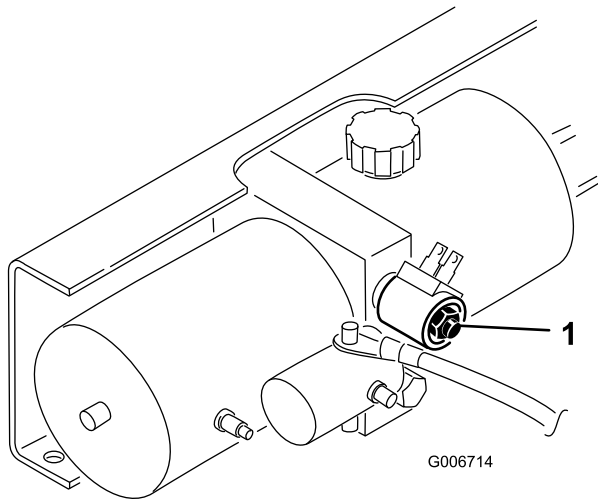

Figure 24

1. Emergency lowering valve knob
-
3. To stop lift and return to normal operation, push button in, rotate 180 degrees clockwise and release.



Falling or jumping from raised platform will cause personal injury.

- Secure both handrail snap chains across opening before raising platform.
- Never pull on objects while reaching from raised platform.
- Never reach over handrails unless both feet are on platform deck.
- Never step above level of platform deck or use ladders, step risers or platform rails to extend working height of platform.
- If you must exit raised platform, slowly and carefully climb down outside of scissor arm frame.

Operating Tips

The electrical system, battery and hydraulic lift cylinder are not designed for continuous use. Allow some time, approximately 1-1/2 to 2 minutes, between lift operations to maintain operating temperatures.

Frequent use without the engine running or idling, between lift use, may discharge the battery. If engine operation is not possible to keep battery charged, it may be necessary to supplement operation with an overnight battery charger.

Check the specific gravity of the fluid in the battery to assure it is fully charged. Refer to Battery Care section.



Tip-over of Workman Vehicle while platform is raised will result in personal injury to operator and/or bystanders.

- Always park vehicle on firm, level surface before raising platform.
- Never exceed 5 degree maximum angle of operation.
- Never raise platform if bubble level indicator is outside recommended operating range.
- Never raise platform if one or more vehicle tires under inflated; check tire pressure daily.
- Never pull on objects while reaching from raised platform.
- Never use platform for carrying or lowering tree limbs, branches or heavy or uneven loads.
- Never exceed capacity of platform lift (one person with equipment not to exceed 600 lbs.)
- Never raise platform during high winds or threatening weather.
- Never by-pass safety interlocks.
- Never allow riders on platform in any position.

Note: Top rail of platform lift is higher than vehicle ROPS so be alert to low overhead areas when transporting (driving) vehicle.



Falling objects and overhead obstructions can cause personal injury.

- Always wear hard hat and eye protection while operating platform or while in area below platform.
- Never drop or throw articles from raised platform.
- When raising platform be alert for overhead obstructions which could cause eye, head or crushing injuries.

Maintenance

Check Safety Circuits

The electrical safety circuits of the lift require the vehicle to be parked on a slope of less than 5 degrees, parking brake to be engaged and the ignition key off in order to activate the lift circuit.

To verify parking brake switch operation:

1. Position the vehicle on a level surface, set parking brake and chock wheels.
2. Rotate vehicle key switch to "Off" position. While standing next to machine, grasp pendant control and rotate lift key switch to "On" position. Press "UP" button and raise lift a few inches. Release button.
3. Release parking brake and try to raise lift again. Lift must not rise. If lift does not raise, safety circuit is operating correctly and proceed to next step. If lift rises there is a malfunction in the electrical circuit that must be repaired before operating lift.
4. With the platform partially raised and parking brake released, try to start engine. If engine does not start and remain running, safety circuit is operating correctly. Lower lift all the way and proceed to next step. If engine starts and remains running there is a malfunction in the electrical circuit that must be repaired before operating lift.

To verify rear axle level switch operation:

1. Position one side of vehicle (rear axle) on a slope greater than 5 degrees (floor jack, mound of material or small hill).
2. Set parking brake and chock wheels.
3. Rotate vehicle key switch to "Off" position. While standing next to machine, grasp pendant control and rotate lift key switch to "On" position. Press "UP" button and try to raise lift. If lift does not raise, safety circuit is operating correctly. Raise opposite side of machine and repeat procedure. If lift rises, with either side of machine in raised position, there is a malfunction in the electrical circuit that must be repaired before operating lift. Lower lift immediately.

Battery Care

1. Battery electrolyte level must be properly maintained and the top of the battery kept clean. If the machine is stored in a location where temperatures are extremely high, the battery will run down more rapidly than if the machine is stored in a location where temperatures are cool.
2. Keep top of battery clean by washing periodically with a brush dipped in ammonia or bicarbonate of soda solution. Flush the top surface with water after cleaning. Do not remove the fill cap while cleaning.
3. Battery cables must be tight on terminals to provide good electrical contact.
4. If corrosion occurs at terminals, remove battery cover, disconnect cables, negative (-) cable first and scrape clamps and terminals separately. Reconnect cables, positive (+) cable first and coat terminals with petroleum jelly.
5. Check the electrolyte level every 50 operating hours or, if machine is in storage, every 30 days.
6. Maintain cell level with distilled or demineralized water. Do not fill cells above the bottom of the fill ring inside each cell.
7. If the machine will be stored for more than 30 days, remove the battery and charge it fully. Either store it on the shelf or on the machine. Leave the cables disconnected if stored on the machine. Store the battery in a cool atmosphere to avoid quick deterioration of the charge in the battery. To prevent battery from freezing, make sure it is fully charged. The specific gravity of a fully charged battery is 1.250.



Battery electrolyte contains sulfuric acid which is a deadly poison and it causes severe burns.

- **If you carelessly drink electrolyte you could die or if it gets onto your skin you will be burned.**
- **Do not drink electrolyte and avoid contact with skin, eyes or clothing.**
- **Wear safety glasses to shield your eyes and rubber gloves to protect your hands.**
- **Fill the battery where clean water is always available for flushing the skin.**
- **Follow all instructions and comply with all safety messages on the electrolyte container.**

Warning

CALIFORNIA Proposition 65 Warning

Battery posts, terminals, and related accessories contain lead and lead compounds, chemicals known to the State of California to cause cancer and reproductive harm.
Wash hands after handling.



Charging the battery produces gasses that can explode.

Never smoke near the battery and keep sparks and flames away from battery.



Battery terminals or metal tools could short against metal components causing sparks. Sparks can cause the battery gasses to explode, resulting in personal injury.

- When removing or installing the battery, do not allow the battery terminals to touch any metal parts of the machine.
- Do not allow metal tools to short between the battery terminals and metal parts of the machine.



Incorrect battery cable routing could damage the machine and cables causing sparks. Sparks can cause the battery gasses to explode, resulting in personal injury.

- Always disconnect the negative (black) battery cable before disconnecting the positive (red) cable.
- Always connect the positive (red) battery cable before connecting the negative (black) cable.

Schematics

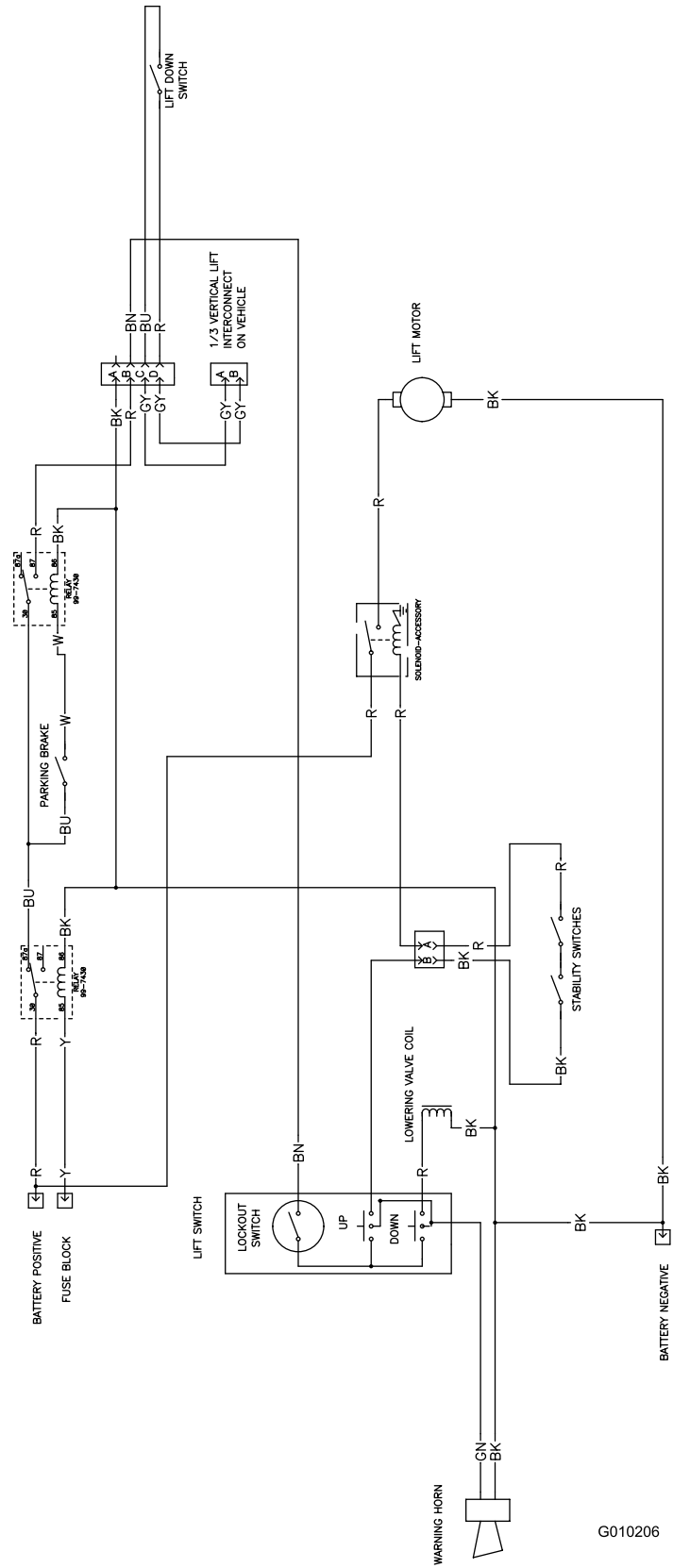

G010206

Electrical Schematic (Rev. B)

Notes:



Toro General Commercial Products Warranty

A Two-Year Limited Warranty

Conditions and Products Covered

The Toro Company and its affiliate, Toro Warranty Company, pursuant to an agreement between them, jointly warrant your Toro Commercial Product ("Product") to be free from defects in materials or workmanship for two years or 1500 operational hours*, whichever occurs first. This warranty is applicable to all products with the exception of Aerators (refer to separate warranty statements for these products). Where a warrantable condition exists, we will repair the Product at no cost to you including diagnosis, labor, parts, and transportation. This warranty begins on the date the Product is delivered to the original retail purchaser.

* Product equipped with hour meter

Instructions for Obtaining Warranty Service

You are responsible for notifying the Commercial Products Distributor or Authorized Commercial Products Dealer from whom you purchased the Product as soon as you believe a warrantable condition exists. If you need help locating a Commercial Products Distributor or Authorized Dealer, or if you have questions regarding your warranty rights or responsibilities, you may contact us at:

Toro Commercial Products Service Department
Toro Warranty Company
8111 Lyndale Avenue South
Bloomington, MN 55420-1196
952-888-8801
E-mail: commercial.warranty@toro.com

Owner Responsibilities

As the Product owner, you are responsible for required maintenance and adjustments stated in your *Operator's Manual*. Failure to perform required maintenance and adjustments can be grounds for disallowing a warranty claim.

Items and Conditions Not Covered

Not all product failures or malfunctions that occur during the warranty period are defects in materials or workmanship. This warranty does not cover the following:

- Product failures which result from the use of non-Toro replacement parts, or from installation and use of add-on, or modified non-Toro branded accessories and products. A separate warranty may be provided by the manufacturer of these items.
- Product failures which result from failure to perform recommended maintenance and/or adjustments. Failure to properly maintain your Toro product per the Recommended Maintenance listed in the *Operator's Manual* can result in claims for warranty being denied.
- Product failures which result from operating the Product in an abusive, negligent or reckless manner.
- Parts subject to consumption through use unless found to be defective. Examples of parts which are consumed, or used up, during normal Product operation include, but are not limited to, brakes pads and linings, clutch linings, blades, reels, bed knives, tines, spark plugs, castor wheels, tires, filters, belts, and certain sprayer components such as diaphragms, nozzles, and check valves, etc.
- Failures caused by outside influence. Items considered to be outside influence include, but are not limited to, weather, storage practices, contamination, use of unapproved coolants,

lubricants, additives, fertilizers, water, or chemicals, etc.

- Normal noise, vibration, wear and tear, and deterioration.
- Normal "wear and tear" includes, but is not limited to, damage to seats due to wear or abrasion, worn painted surfaces, scratched decals or windows, etc.

Parts

Parts scheduled for replacement as required maintenance are warranted for the period of time up to the scheduled replacement time for that part. Parts replaced under this warranty are covered for the duration of the original product warranty and become the property of Toro. Toro will make the final decision whether to repair any existing part or assembly or replace it. Toro may use remanufactured parts for warranty repairs.

Note Regarding Deep Cycle Battery Warranty:

Deep cycle batteries have a specified total number of kilowatt-hours they can deliver during their lifetime. Operating, recharging, and maintenance techniques can extend or reduce total battery life. As the batteries in this product are consumed, the amount of useful work between charging intervals will slowly decrease until the battery is completely worn out. Replacement of worn out batteries, due to normal consumption, is the responsibility of the product owner. Battery replacement may be required during the normal product warranty period at owner's expense.

Maintenance is at Owner's Expense

Engine tune-up, lubrication cleaning and polishing, replacement of filters, coolant, and completing Recommended Maintenance are some of the normal services Toro products require that are at the owner's expense.

General Conditions

Repair by an Authorized Toro Distributor or Dealer is your sole remedy under this warranty.

Neither The Toro Company nor Toro Warranty Company is liable for indirect, incidental or consequential damages in connection with the use of the Toro Products covered by this warranty, including any cost or expense of providing substitute equipment or service during reasonable periods of malfunction or non-use pending completion of repairs under this warranty. Except for the Emissions warranty referenced below, if applicable, there is no other express warranty. All implied warranties of merchantability and fitness for use are limited to the duration of this express warranty.

Some states do not allow exclusions of incidental or consequential damages, or limitations on how long an implied warranty lasts, so the above exclusions and limitations may not apply to you. This warranty gives you specific legal rights, and you may also have other rights which vary from state to state.

Note regarding engine warranty:

The Emissions Control System on your Product may be covered by a separate warranty meeting requirements established by the U.S. Environmental Protection Agency (EPA) and/or the California Air Resources Board (CARB). The hour limitations set forth above do not apply to the Emissions Control System Warranty. Refer to the Engine Emission Control Warranty Statement printed in your *Operator's Manual* or contained in the engine manufacturer's documentation for details.

Countries Other than the United States or Canada

Customers who have purchased Toro products exported from the United States or Canada should contact their Toro Distributor (Dealer) to obtain guarantee policies for your country, province, or state. If for any reason you are dissatisfied with your Distributor's service or have difficulty obtaining guarantee information, contact the Toro importer.