



## Commercial Walk-Behind Mower Floating Deck T-Bar Gear with 32in Cutting Unit

Model No. 30092 - 290000001 and up.

### Parts Catalog

---

#### Ordering Replacement Parts

To order replacement parts, please supply the part number, the quantity, and the description of each part desired.

#### Understanding Reference Numbers

Each identified part in an illustration has a reference number. The reference number for a part also appears in the parts list, along with other information about the part.

This catalog uses two special reference number formats, one to indicate parts in a service assembly and another to indicate the quantity of a given part in an illustration.

#### Service Assembly Reference Numbers

Parts in service assemblies have reference numbers in the form a:b. The a represents the reference number of the entire service assembly and the b represents a sequential number unique to each part within the service assembly.

For example, a wheel assembly might be identified by reference number 6, the tire by 6:1, the valve by 6:2, and the wheel by 6:3. When you order the assembly identified by reference number 6, you receive all parts identified by reference numbers 6:1, 6:2, and 6:3. However, you may also order any part individually. Reference numbers of this type appear in illustrations and in part lists.

#### Reference Numbers Indicating Quantity

In an illustration, if a reference number indicates more than one part, the reference number has the form nX y. The n represents the quantity of the part, the X is the multiplication symbol, and the y represents the reference number.

For example, in an illustration, the reference number 2X 37 means that two of the parts identified by reference number 37 are indicated.

# Contents

Description	Page	Description	Page
Fuel Tank and Idler Bracket Assembly	3	Lubrication Equipment Assembly Kawasaki FH430V-AS35	15
Transmission and Idler Pulley Assembly	4	Cooling Equipment Assembly Kawasaki FH430V-AS35	16
Brake, Wheel Pulley and Wheel Assembly	5	Electric Equipment Assembly Kawasaki FH430V-AS35	17
Handle and Control Panel Assembly	6	Control Equipment Assembly Kawasaki FH430V-AS35	18
Engine Assembly	7	Carburetor Assembly Kawasaki FH430V-AS35	19
Carrier Assembly	8	Air Filter and Muffler Assembly Kawasaki FH430V-AS35	20
Deck Assembly	9	Fuel Tank and Valve Assembly Kawasaki FH430V-AS35	21
Spindle and Blade Assembly	10	Starter Assembly Kawasaki FH430V-AS35	22
Decal and Mulcher Cover Assembly	11	Label Assembly Kawasaki FH430V-AS35	23
Cylinder and Crankcase Assembly Kawasaki FH430V-AS35	12	Attachments and Accessories List	24
Piston and Crankshaft Assembly Kawasaki FH430V-AS35	13		
Valve and Camshaft Assembly Kawasaki FH430V-AS35	14		

## Part Description Abbreviations

Part descriptions in this catalog may include the following abbreviations.

AR. .... as required	HWHTF. .... hex washer head thread forming
ASM. .... assembly	HYD. .... hydraulic
BBC. .... blade brake clutch	LH. .... left hand
CARR. .... carriage	NI. .... nylon insert
CCW. .... counter clock wise	NPTF. .... national pipe thread fine
CW. .... clockwise	PFH. .... phillips flat head
DEG. .... degrees	PPH. .... phillips pan head
ECM. .... electronic control module	PPHTF. .... phillips pan head thread forming
EXT. .... external	PRH. .... phillips round head
FH. .... flat head	PTH. .... phillips truss head
GA. .... gauge	PTO. .... power-take-off
HD. .... heavy-duty	RH. .... right hand
HF. .... hex flange	ROPS. .... roll-over protection system
HH. .... hex head	SFH. .... slotted fillister head
HHF. .... hex head flange	SHH. .... slotted hex head
HHFTF. .... hex head flange thread forming	SHWH. .... slotted hex washer head
HJ. .... hex jam	SPH. .... slotted pan head
HLH. .... hex lag head	SQH. .... square head
HOC. .... height-of-cut	SRH. .... slotted round head
HSBH. .... hex socket button head	STD. .... standard
HSFH. .... hex socket flat head	TAP. .... self tapping
HSH. .... hex socket head	TTH. .... torx truss head
HWH. .... hex washer head	

## Footnotes

❶ Not serviced separately

❷ Obtain parts from [www.kawpowerepc.com](http://www.kawpowerepc.com)

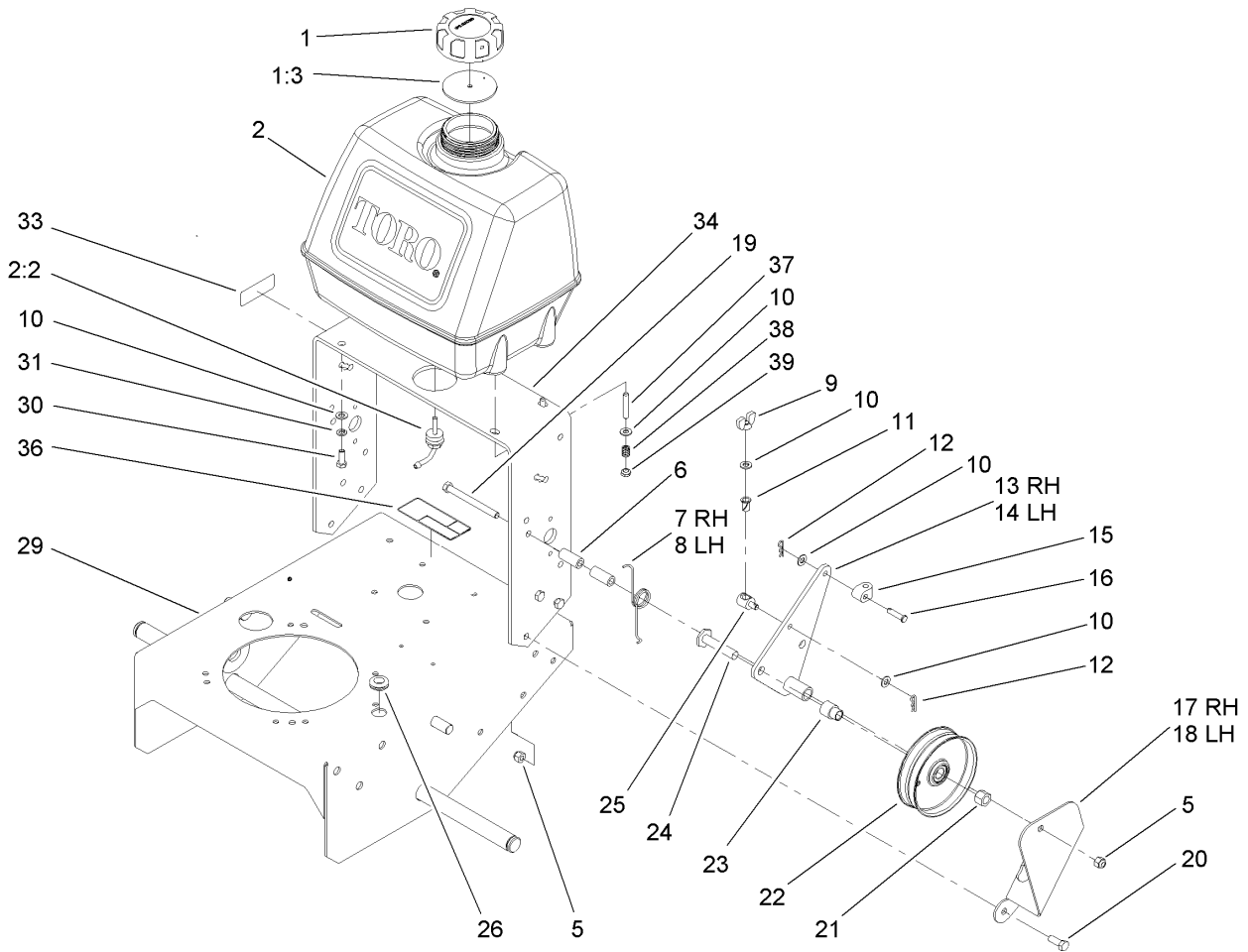

## Fuel Tank and Idler Bracket Assembly

Ref	Part No.	Qty.	Description
1	88-3980	1	Gas Cap ASM
1:3	88-4010	1	Gasket-Cap, Gas
2	106-0730	1	Fuel Tank ASM
2:2	103-2605	1	Fitting-Fuel, Bulkhead
5	3296-39	8	Nut-Lock, NI
6	74-0040	4	Spacer-Pivot, Idler
7	51-4370	1	Spring-Torsion, RH
8	51-4380	1	Spring-Torsion, LH
9	32103-25	2	Nut-Wing
10	3256-23	12	Washer-Flat
11	52-2890	2	Bushing-Nylon
12	3290-307	4	Pin-Hair
13	108-2741-01	1	RH Idler Arm ASM
14	108-2740-01	1	LH Idler Arm ASM
15	74-0521	2	Fitting-Rod
16	283-6	2	Pin-Clevis
17	67-6370-01	1	Bracket-Support, RH
18	67-6380-01	1	Bracket-Support, LH
19	323-16	2	Screw-HH
20	323-6	6	Screw-HH
21	3296-23	2	Nut-Lock, NI
22	95-2800	2	Pulley-Idler
23	95-2801	2	Spacer-Pulley
24	51-4450	2	Screw-Leveler

Ref	Part No.	Qty.	Description
25	68-9690	2	Fitting-Rod
26	237-124	1	Grommet
29	105-4670-01	1	Frame ASM
30	322-4	4	Screw-HH
31	3253-4	2	Washer-Lock
33	95-2814	1	Decal-Shut Off, Fuel
34	106-0649-01	1	Frame-Upper
36	98-0776	1	Decal-Caution
37	104-8121	2	Stud-Threaded
38	1-633349	2	Spring-Tank, Fuel
39	3296-47	2	Nut-Lock, NI

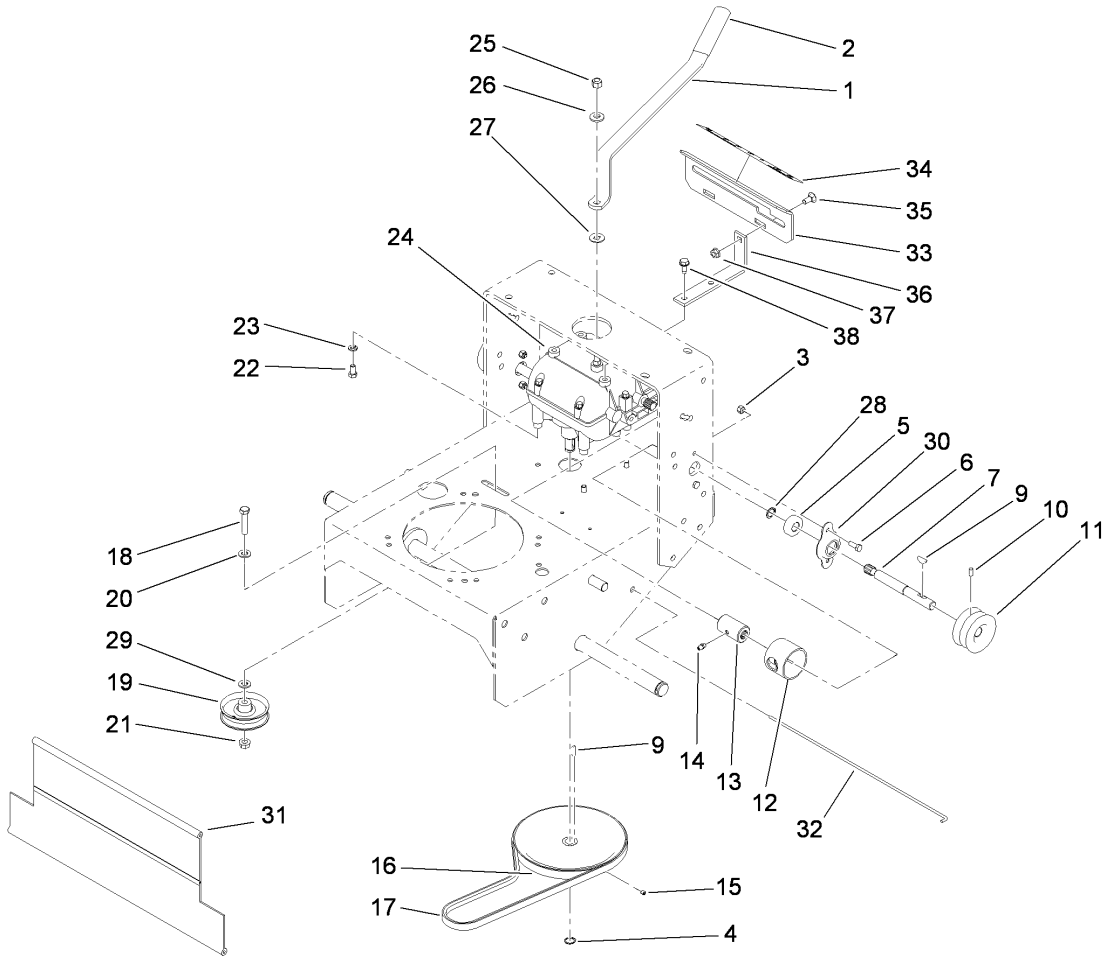

## Transmission and Idler Pulley Assembly

Ref	Part No.	Qty.	Description
1	98-3274-03	1	Lever-Shift
2	47-1970	1	Grip
3	3296-42	4	Nut-Lock, NI
4	32120-64	1	Ring-Snap, External
5	1-323252	2	Bearing-Shaft
6	321-4	4	Screw-HH
7	104-1102	2	Shaft-Output
9	3257-5	3	Key-Woodruff
10	3245-9	2	Screw-Set
11	105-2698	2	Pulley-Transmission
12	51-4220	2	Guard-Coupler
13	1-323680	2	Coupler
14	302-5	2	Fitting-Grease
15	3245-1	1	Screw-Set, HSH
16	51-4190	1	Pulley-Driven
17	26-9671	1	Belt V
18	323-9	1	Screw-HH
19	51-4810	1	Pulley-Idler
20	3256-24	1	Washer-Flat
21	32128-21	1	Nut-HF
22	322-2	4	Screw-HH
23	3253-4	4	Washer-Lock
24	1-323500	1	Transmission
25	3296-6	1	Nut-Lock

Ref	Part No.	Qty.	Description
26	98-5975	1	Washer-Belleville
27	1-323379	1	Washer
28	32151-62	2	Ring-Retaining
29	3256-24	1	Washer-Flat
30	1-323254	2	Flange-Output
31	95-1526	1	Shield-Trailing
32	95-1529	1	Rod-Shield
33	1-323387-03	1	Plate-Shift
34	98-3256	1	Decal-Speed, Ground
35	3230-1	2	Bolt-CARR
36	1-323389-03	2	Bracket-Plate, Shift
37	32128-20	2	Nut-HF
38	9264964	4	Screw-HWH, Thread Cut

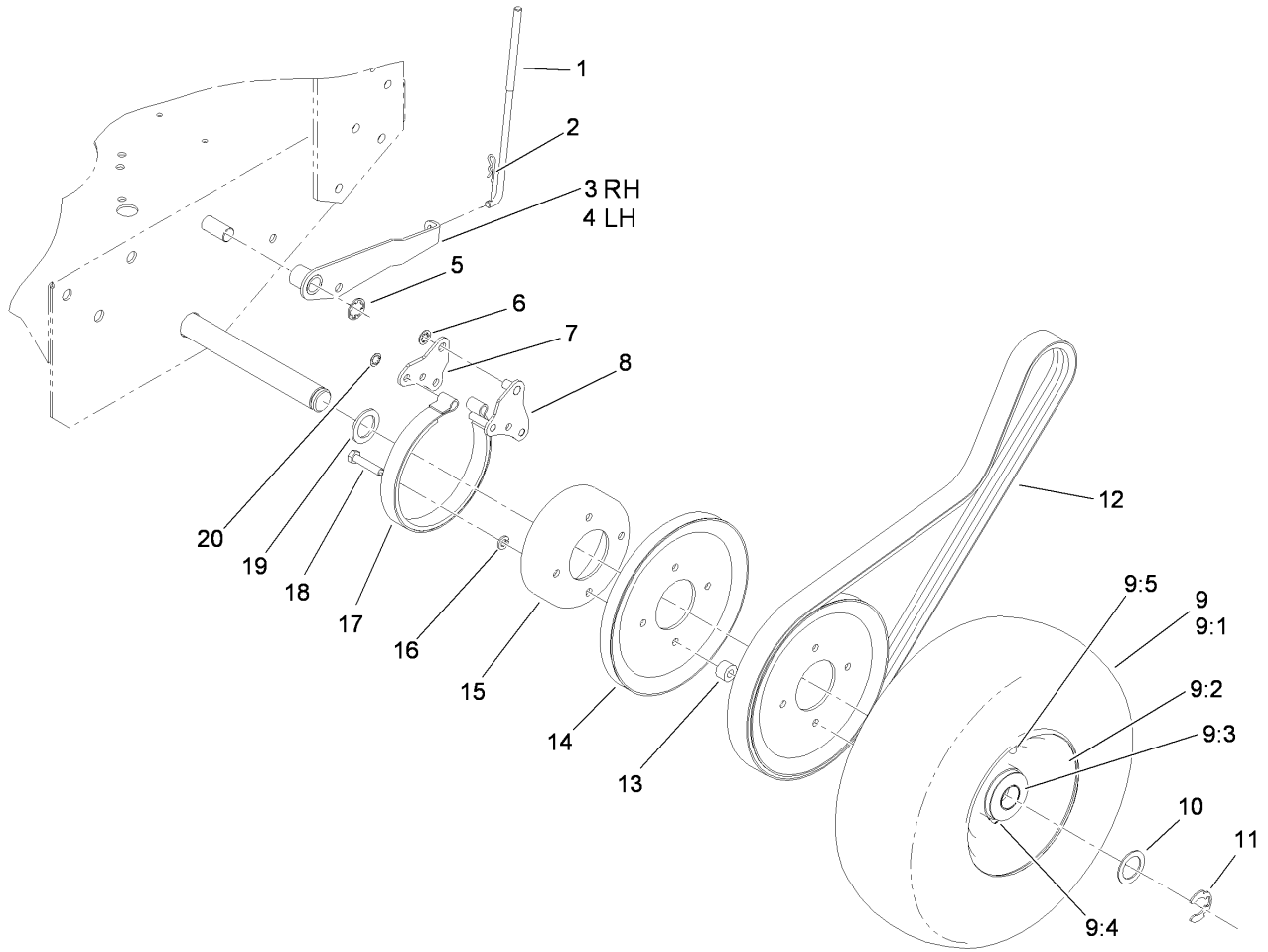

## Brake, Wheel Pulley and Wheel Assembly

Ref	Part No.	Qty.	Description
1	51-4580	2	Rod-Brake
2	3290-307	2	Pin-Hair
3	67-6400-01	1	Arm-Brake, RH
4	67-6420-01	1	Arm-Brake, LH
5	32151-40	2	Ring-Retaining
6	32151-56	2	Ring-Retaining, External
7	51-4660-01	2	Plate-Link, Brake
8	51-4650-01	2	Link-Brake
9	93-1163	2	Wheel And Tire ASM
9:1	231-94	1	Tire-Front
9:2	93-1181	1	Wheel ASM
9:3	92-1746	2	Bearing-Ball
9:4	302-57	1	Fitting-Grease
9:5	232-27	1	Stem-Valve
10	10-8110	8	Washer-Thrust
11	32151-91	2	Ring-Retaining
12	51-4291	2	V-Belt
13	51-4170	8	Spacer-Pulley
14	51-4160-03	4	Pulley-Wheel
15	51-4180-03	2	Drum-Brake
16	3253-4	8	Washer-Lock
17	51-4700	2	Band-Brake
18	322-7	8	Screw-HH
19	51-4230	2	Washer-Wheel

Ref	Part No.	Qty.	Description
20	32151-72	4	Ring-Retaining

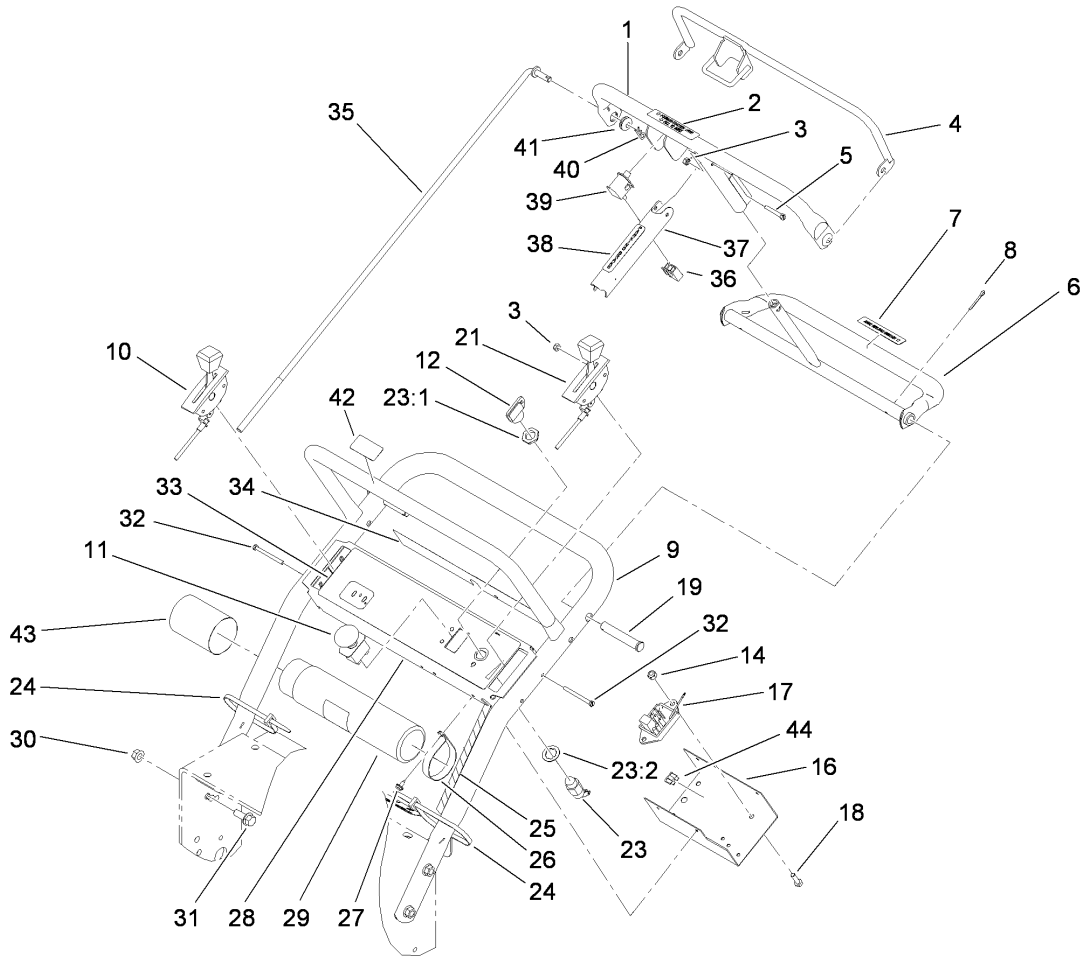

## Handle and Control Panel Assembly

Ref	Part No.	Qty.	Description
1	82-7690-03	1	Bar-Control
2	82-2290	1	Decal
3	3296-2	5	Nut-Lock, NI
4	82-7680-03	1	Bail ASM
5	32105-1	1	Screw-SHH
6	106-5477-03	1	Control Pivot ASM
7	82-2280	1	Decal
8	3272-11	2	Pin-Cotter
9	105-3158-03	1	Upper Handle ASM
10	112-8712	1	Cable-Choke
11	104-8140	1	Switch-PTO
12	63-8360	2	Key-Ignition
14	3296-42	1	Nut-Lock, NI
16	93-1187-03	1	Panel-Bottom
17	104-8141	1	Module-Delay
18	321-2	1	Screw-HH
19	283-55	2	Pin-Clevis
21	112-8711	1	Cable-Throttle
23	29-5560	1	Switch-On / Off
23:1	218-461	1	Nut-HH
23:2	3254-5	1	Washer-Tooth
24	3290-378	2	Tie-Cable
25	104-8137	1	Harness-Wire
26	2412-120	2	R-Clamp

Ref	Part No.	Qty.	Description
27	32104-76	4	Screw
28	110-4982-03	1	Panel-Control
29	104-7050	1	Tube-Manual
30	32128-21	4	Nut-HF
31	3234-11	4	Screw-HHF
32	32105-14	4	Screw-SHH
33	110-4971	1	Decal-Control Panel
34	105-0884	1	Decal-Danger
35	82-7632	2	Rod-Control
36	218-595	1	Connector-Body
37	51-4850-03	1	Lever-Brake, Parking
38	52-2010	1	Decal-Lever, Parking
39	82-2190	1	Switch-Bail
40	3290-307	2	Pin-Hair
41	237-141	2	Grommet-Rubber
42	98-4387	1	Decal-Protection, Ear
43	104-7048	1	Cap-Housing
44	114241	1	Fuse-7.5 Amp

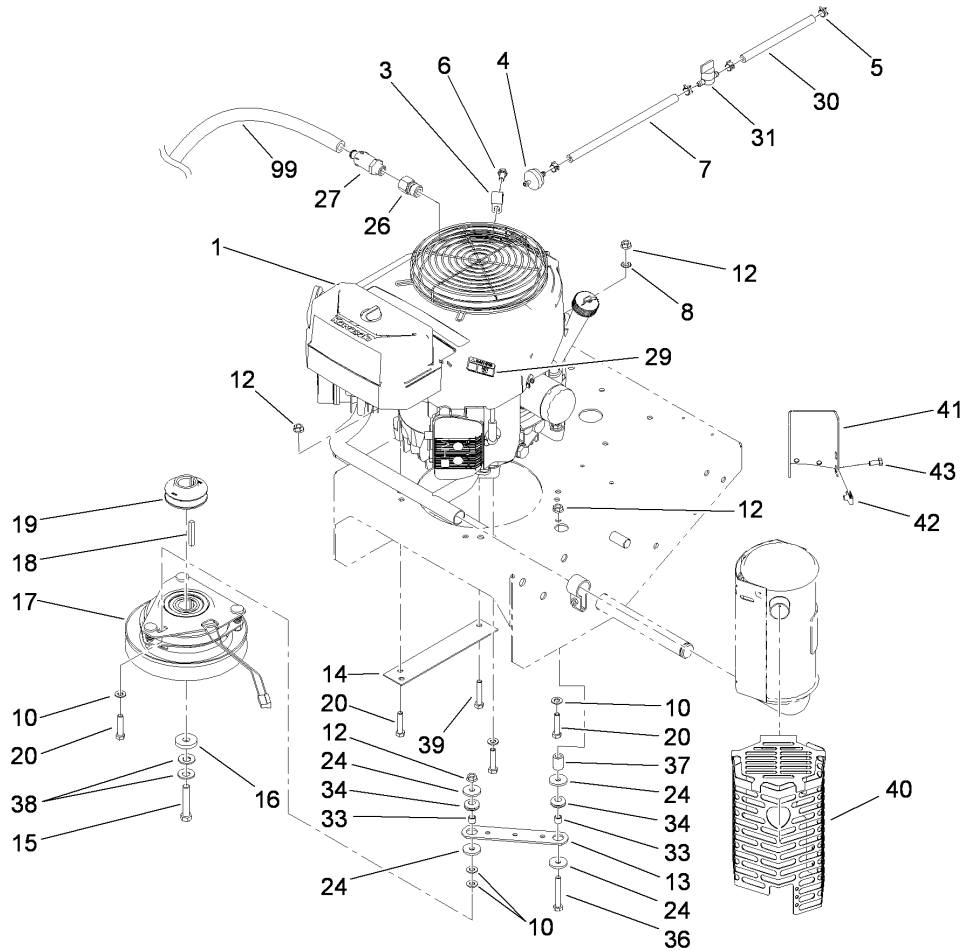

## Engine Assembly

Ref	Part No.	Qty.	Description	Ref	Part No.	Qty.	Description
1		1	Engine-Kawasaki, FH430V-As35	34	1-633630	2	Grommet-Brake
3	2412-87	1	Clamp-Cable	36	322-11	1	Screw-HH
4	56-6360	1	Filter-Fuel	37	104-6373	1	Tube-Retainer
5	2412-98	4	Clamp	38	1-603610	2	Washer-Spring
6	33114-016	1	Screw-HH	39	322-9	1	Screw-HH
7	110-4894	1	Hose-Fuel	40	115-4150-03	1	Muffler Shield ASM
8	3255-8	1	Washer-Lock	41	115-4154-03	1	Bracket-Muffler
10	3256-23	5	Washer-Flat	42	94-2413	4	U-Nut
12	32128-20	6	Nut-HF	43	322-3	4	Screw-HH
13	1-633543-03	1	Strap-Clutch, Brake	99	103-1964	1	Hose-Drain, Oil
14	94-5847-01	1	Cover-Pulley				
15	3212-9	1	Screw-HH				
16	107-4136	1	Washer				
17	105-2635	1	Clutch / Brake				
18	608006	1	Key-Square				
19	107-4112	1	Pulley-Drive				
20	322-7	4	Screw-HH				
24	1-613235	4	Washer				
26	103-1966	1	Adapter				
27	92-6877	1	Valve-Drain, Oil				
29	106-0699	1	Decal-Warning				
30	107-0588	1	Hose-Fuel				
31	1-603770	1	Valve-Fuel				
33	1-633545	2	Spacer				

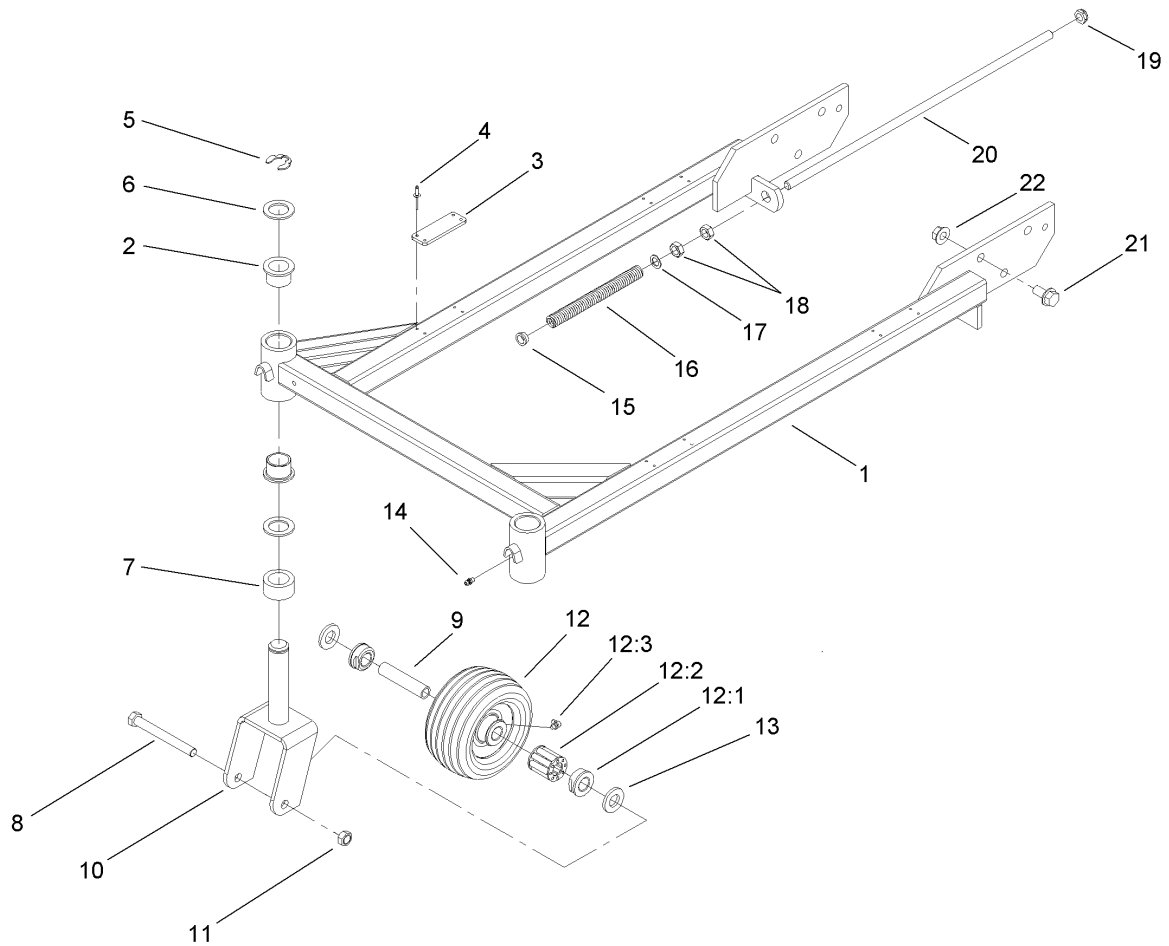

### Carrier Assembly

Ref	Part No.	Qty.	Description
1	74-0080	1	Carrier Frame ASM
2	94-1291	4	Bushing
3	74-0330	4	Pad-Rubber
4	3269-24	16	Rivet
5	32151-91	2	Ring-Retaining
6	3-6781	4	Washer-Thrust
7	93-1166	2	Spacer-Castor
8	325-18	2	Screw-HH
9	67-6220	2	Spanner
10	93-1164-01	2	Fork-Caster ASM
11	32153-5	2	Nut-Lock, Side
12	63-8400	2	Caster Wheel ASM
12:1	62-5580	2	Bearing-Outside
12:2	63-8580	1	Bearing-Roller
12:3	302-40	1	Fitting-Grease
13	67-6570	4	Spacer-Wheel
14	302-5	2	Fitting-Grease
15	256-156	2	Bushing-Flange
16	74-0290	2	Spring
17	41-8440	2	Washer
18	3218-5	4	Nut-Jam
19	74-0310	2	Shaft-Adjusting
20	3296-45	2	Nut-Lock, NI
21	3234-6	6	Screw-HHF

Ref	Part No.	Qty.	Description
22	32128-23	6	Nut-HF

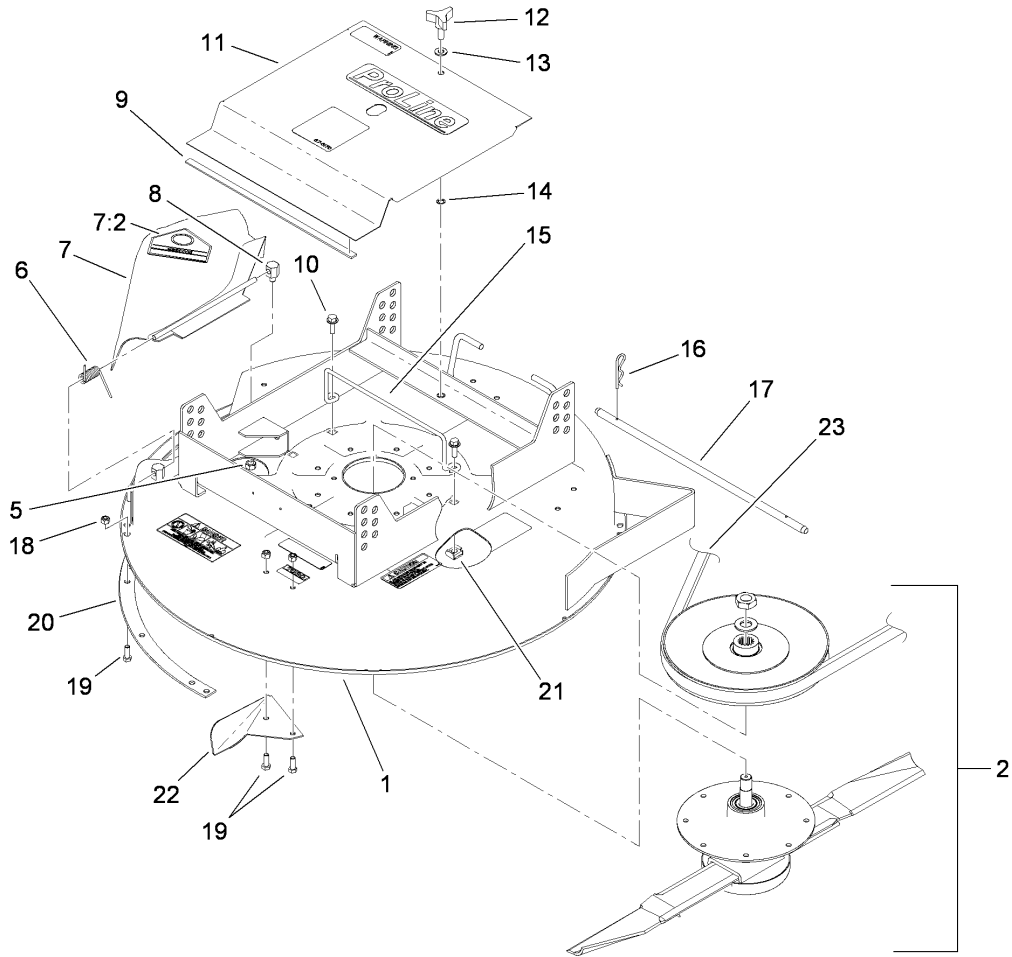

## Deck Assembly

Ref	Part No.	Qty.	Description
1	14-5079	1	32 Inch Deck ASM W/ Decals
①2		1	Spindle ASM
5	32153-2	1	Nut-Lock, Side
6	28-8010	1	Spring
7	44-5930	1	Deflector ASM
7:2	54-9220	1	Decal-Danger
8	28-7350	1	Post-Pivot
9	67-6180	1	Strip-Magnetic
10	3234-29	2	Screw-HHF
11	67-6160-01	1	Cover
12	104-8587	1	Knob
13	3256-24	1	Washer-Flat
14	32151-72	1	Ring-Retaining
15	74-0570	1	Guide-Belt
16	3290-355	4	Pin-Hair
17	67-6140	2	Rod-Support
18	3296-29	24	Nut-Lock, NI
19	322-4	24	Screw-HH
20	92-5419-03	4	Ring-Recycler
21	3290-496	2	Nut-Retainer
22	80-2630-03	4	Kicker
23	67-6920	1	V-Belt



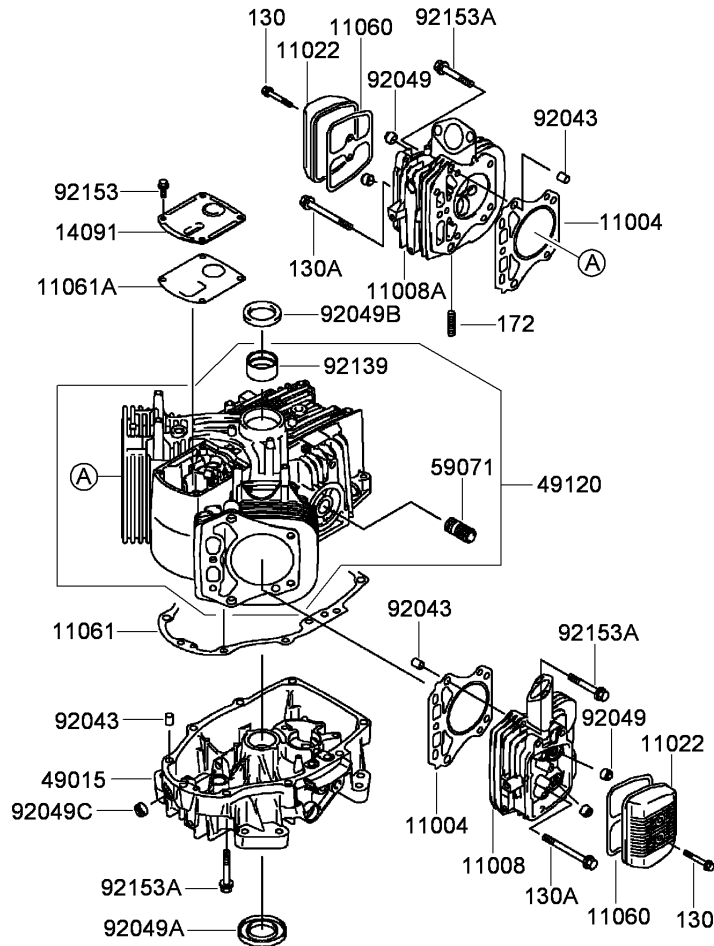

## Cylinder and Crankcase Assembly Kawasaki FH430V-AS35

Ref	Part No.	Qty.	Description
②	11004	2	Gasket-Head
②	11008	1	Head-Cylinder, No. 2
②	11008A	1	Head-Cylinder, No. 1
②	11022	2	Case-Rocker
②	11060	2	Gasket-Case, Rocker
②	11061	1	Gasket-Cover, Crankcase
②	11061A	1	Gasket-Breather
②	14091	1	Cover
②	49015	1	Cover-Crankcase
②	49120	1	Crankcase
②	59071	1	Joint
②	92043	6	Pin
②	92049	4	Seal-Oil, R V C2 (6X11X10.2)
②	92049A	1	Seal-Oil, S D (35X62X8 L HSH)
②	92049B	1	Seal-Oil, S D (35X48X8 R HSH)
②	92049C	1	Seal-Oil, S O (8X14X5 HSH)
②	92139	1	Bushing
②	92153	4	Bolt (6X12)
②	92153A	17	Bolt (8X50)
②	130	4	Bolt-Flanged (6X40)
②	130A	2	Bolt-Flanged (8X75)
②	172	4	Bolt-Stud (8X18)

--	--	--	--

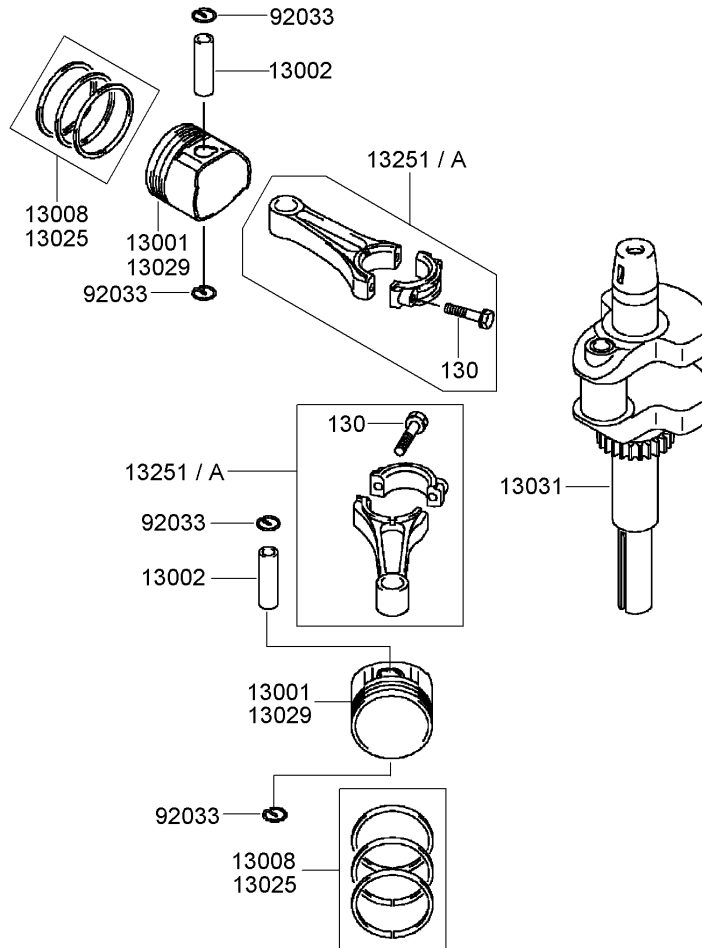

## Piston and Crankshaft Assembly Kawasaki FH430V-AS35

Ref	Part No.	Qty.	Description				
② 13001	13001-7022	2	Piston-Engine				
② 13002	13002-7001	2	Pin-Piston				
② 13008	13008-7001	2	Piston Ring Set				
② 13025	13025-7003	1	Piston Ring Set (L 0.50)				
② 13029	13029-7005	1	Piston-Engine (L 0.50)				
② 13031	13031-7033	1	Crankshaft				
② 13251	13251-7007	2	Connecting Rod ASM				
② 13251A	13251-7008	2	Connecting Rod ASM (0.50)				
② 92033	92033-7002	4	Ring-Snap				
② 130	130G0630	4	Bolt-Flanged (6X30)				

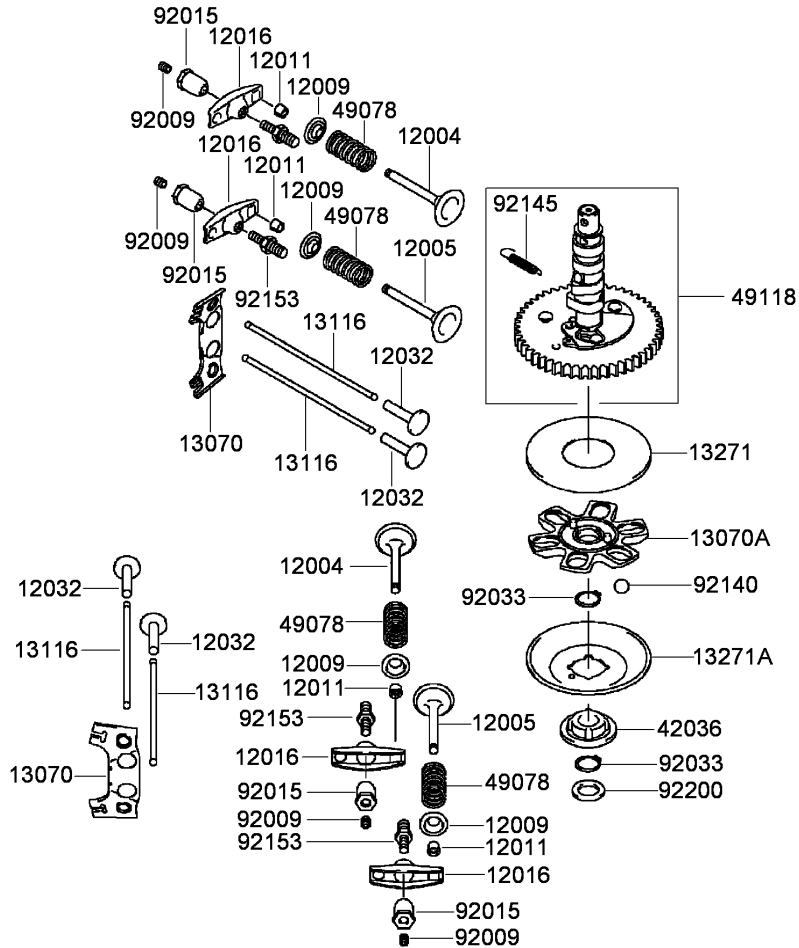

## Valve and Camshaft Assembly Kawasaki FH430V-AS35

Ref	Part No.	Qty.	Description
②	12004	2	Valve-Intake
②	12005	2	Valve-Exhaust
④	12009	4	Retainer-Spring, Valve
⑧	12011	8	Collet
④	12016	4	Arm-Rocker
④	12032	4	Tappet
②	13070	2	Guide
①	13070A	1	Guide
④	13116	4	Rod-Push
①	13271	1	Plate
①	13271A	1	Plate-Governor
①	42036	1	Sleeve
④	49078	4	Spring-Valve, Engine
①	49118	1	Camshaft
④	92009	4	Screw
④	92015	4	Nut
②	92033	2	Ring-Snap
⑥	92140	6	Ball
①	92145	1	Spring
④	92153	4	Bolt
①	92200	1	Washer

--	--	--	--



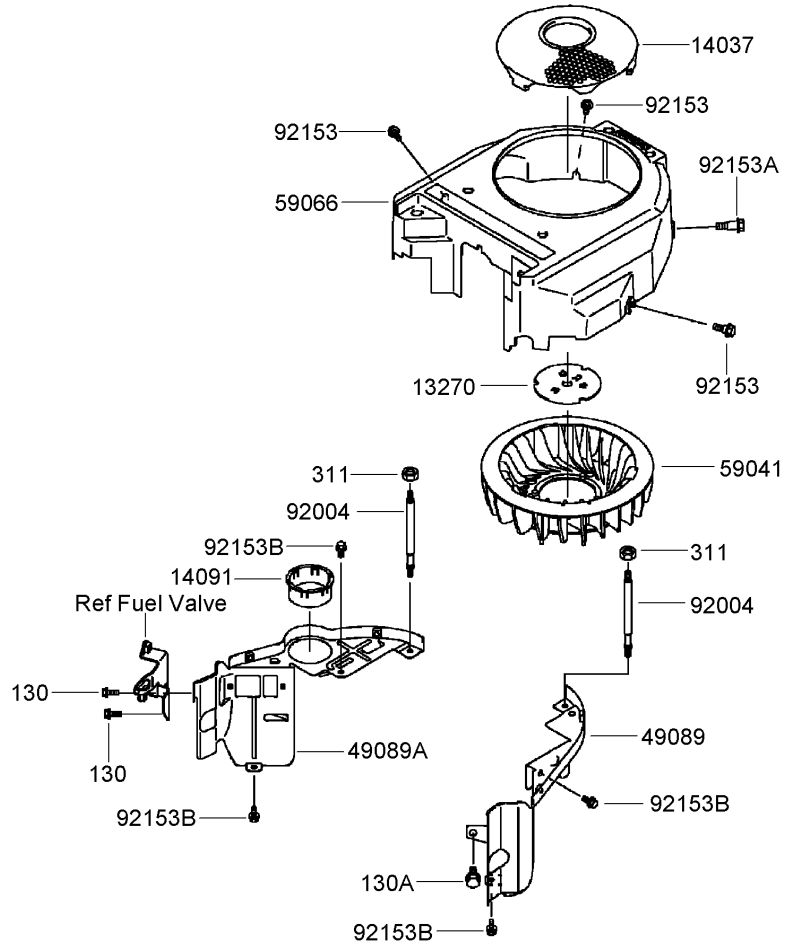

## Cooling Equipment Assembly Kawasaki FH430V-AS35

Ref	Part No.	Qty.	Description
② 13270	13270-7007	1	Plate
② 14037	14037-7025-9H	1	Screen
② 14091	14091-7009	1	Cover
② 49089	49089-7044	1	Shroud-Engine
② 49089A	49089-7061	1	Shroud-Engine
② 59041	59041-7012	1	Fan
② 59066	59066-7036	1	Housing-Fan
② 92004	92004-7007	2	Stud
② 92153	92153-7007	3	Bolt
② 92153A	92153-7008	1	Bolt
② 92153B	92153-7043	4	Bolt (6X12)
② 130	130B0616	2	Bolt-Flanged (6X16)
② 130A	130B0816	1	Bolt-Flanged (8X16)
② 311	311F0600	2	Nut-Hex (6Mm)

--	--	--	--



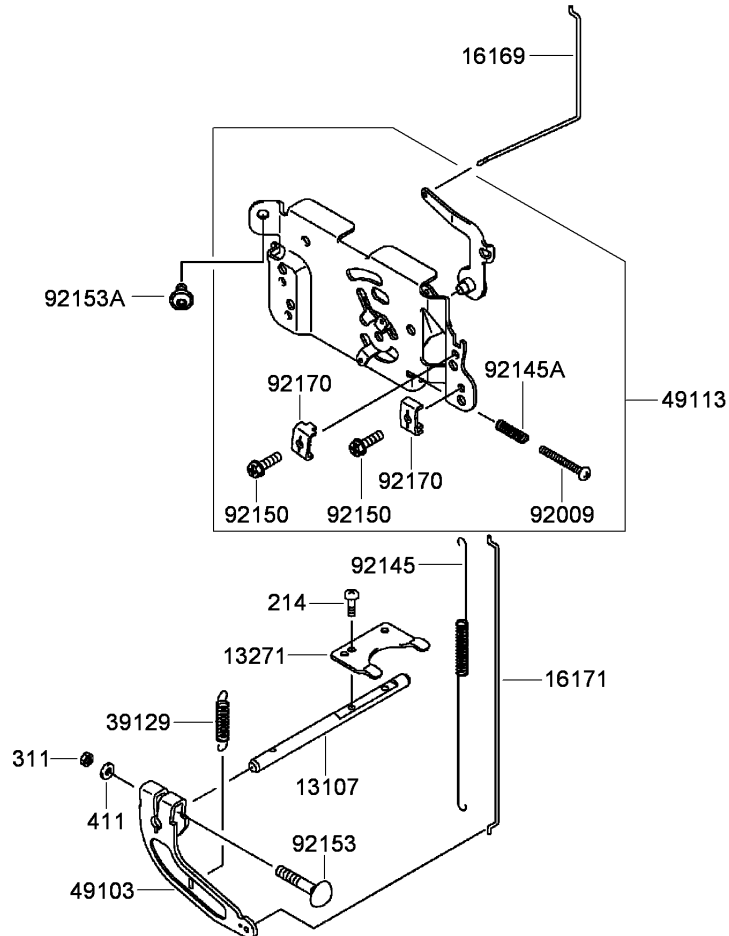

## Control Equipment Assembly Kawasaki FH430V-AS35

Ref	Part No.	Qty.	Description				
●	13107	1	13107-7010	1	Shaft		
●	13271	1	13271-7032	1	Plate		
●	16169	1	16169-7012	1	Link-Choke		
●	16171	1	16171-7007	1	Link		
●	39129	1	39129-7003	1	Spring-Governor		
●	49103	1	49103-7004	1	Arm-Governor		
●	49113	1	49113-7024	1	Panel-Control		
●	92009	1	92009-7007	1	Screw (4X35)		
●	92145	1	92145-7003	1	Spring		
●	92145A	1	92145-7005	1	Spring		
●	92150	2	92150-2182	2	Bolt (5X18)		
●	92153	1	92153-7033	1	Bolt (6X35)		
●	92153A	2	92153-7043	2	Bolt (6X12)		
●	92170	2	92170-7001	2	Clamp		
●	214	2	214B0408	2	Screw-Pan (4X8)		
●	311	1	311B0600	1	Nut-Hex (6Mm)		
●	411	1	411B0600	1	Washer-Plain (6Mm)		

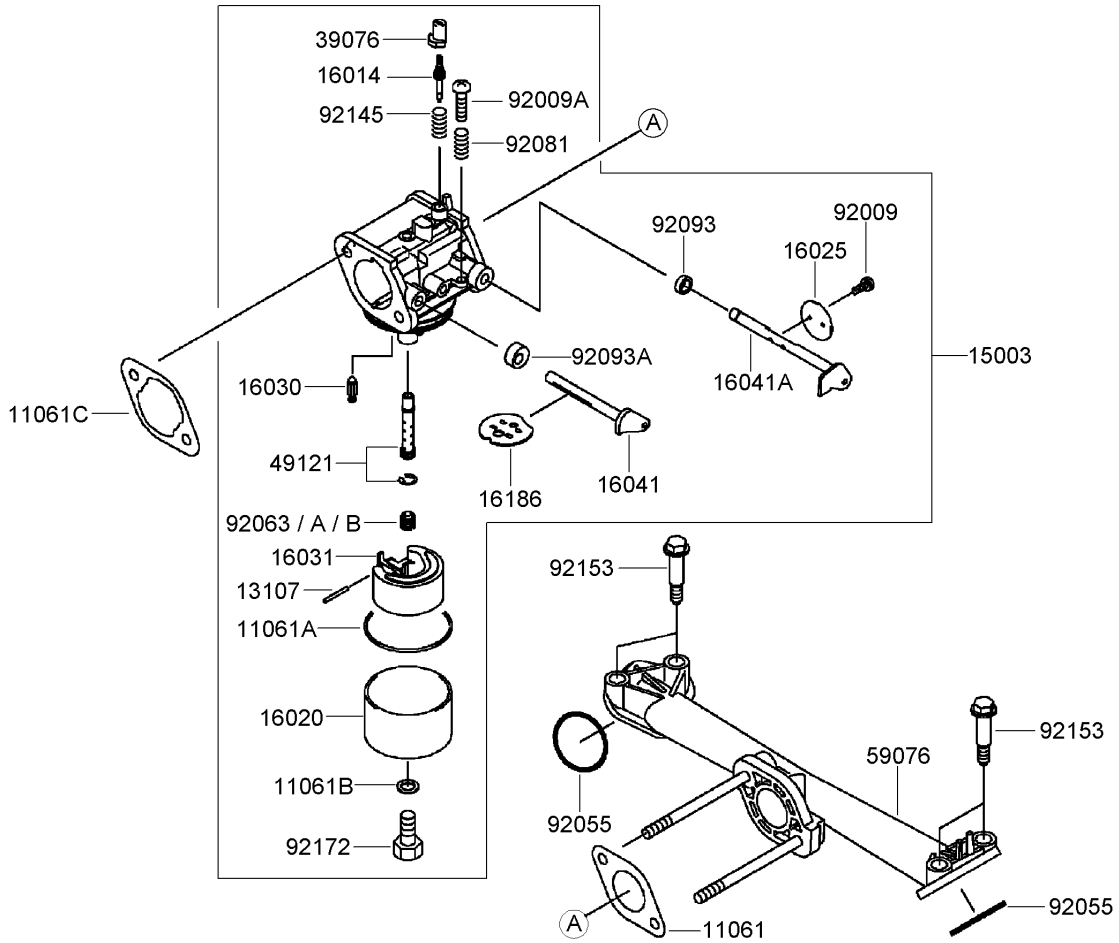

## Carburetor Assembly Kawasaki FH430V-AS35

Ref	Part No.	Qty.	Description
② 11061	11061-7004	1	Gasket-Insulator
② 11061A	11061-7009	1	Gasket-Chamber
② 11061B	11061-7010	1	Gasket-Screw
② 11061C	11061-7018	1	Gasket-Cleaner, Air
② 13107	13107-7018	1	Shaft
② 15003	15003-7061	1	Carburetor ASM
② 16014	16014-7002	1	Screw-Pilot, Air
② 16020	16020-7003	1	Chamber-Float
② 16025	16025-7006	1	Valve-Throttle
② 16030	16030-7003	1	Valve-Float
② 16031	16031-7002	1	Float
② 16041	16041-7016	1	Shaft-Choke, Carburetor
② 16041A	16041-7018	1	Shaft-Throttle, Carburetor
② 16186	16186-7002	1	Choke Valve ASM
② 39076	39076-7001	1	Limiter
② 49121	49121-7001	1	Nozzle-Main
② 59076	59076-7005	1	Manifold-Intake
② 92009	92009-2083	2	Screw
② 92009A	92009-2349	1	Screw
② 92055	92055-7007	2	O-Ring (I D 31)
② 92063	92063-7026	1	Jet-Main, No. 88
② 92063A	92063-7028	1	Jet-Main, No. 85 (3280 Ft)
② 92063B	92063-7029	1	Jet-Main, No.82 (6560 Ft)
② 92081	92081-2234	1	Spring

Ref	Part No.	Qty.	Description
② 92093	92093-2100	1	Seal
② 92093A	92093-7003	1	Seal
② 92145	92145-7015	1	Spring
② 92153	92153-7009	4	Bolt
② 92172	92172-7002	1	Screw

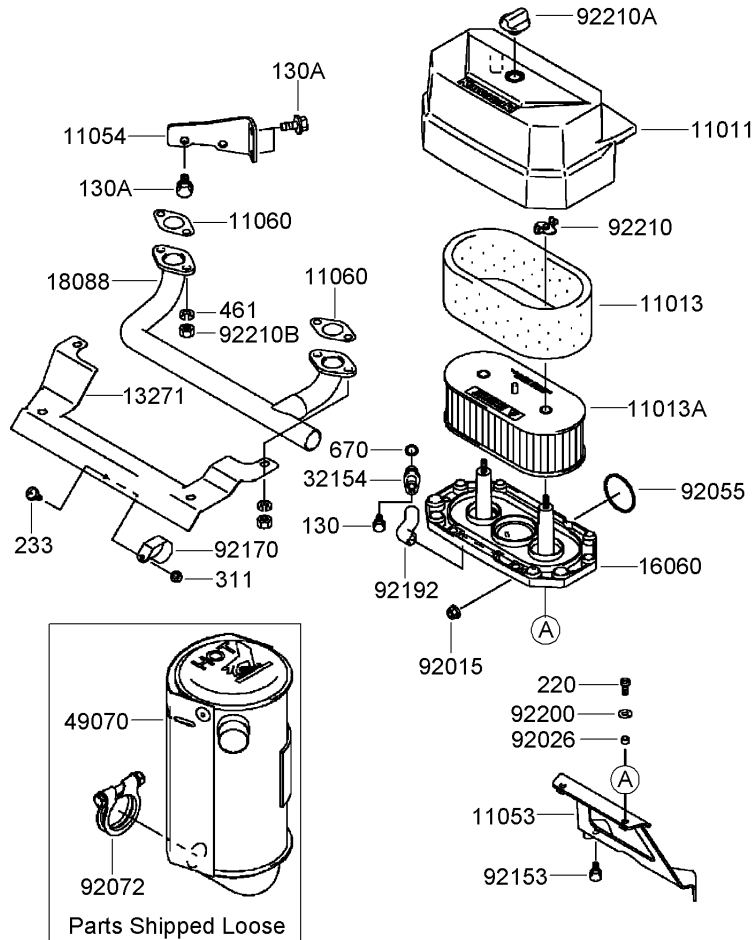

## Air Filter and Muffler Assembly Kawasaki FH430V-AS35

Ref	Part No.	Qty.	Description
②11011	11011-7045	1	Case-Filter, Air
②11013	11013-7025	1	Element-Filter, Air
②11013A	11013-7031	1	Element-Filter, Air
②11053	11053-7022	1	Bracket
②11054	11054-7002-9H	1	Bracket
②11060	11060-7021	2	Gasket-Muffler
②13271	13271-7022	1	Plate
②16060	16060-7016	1	Pipe-Intake
②18088	18088-7001	1	Pipe-Exhaust
②32154	32154-7006	1	Pipe
②49070	49070-7021	1	Muffler
②92015	92015-1193	2	Nut
②92026	92026-7001	2	Spacer (6.2X7.9X5)
②92055	92055-7015	1	O-Ring
②92072	92072-7012	1	Band
②92153	92153-7043	2	Bolt (6X12)
②92170	92170-7002	1	Clamp
②92192	92192-7010	1	Tube
②92200	92200-2070	2	Washer
②92210	92210-7004	2	Nut (M6)
②92210A	92210-7019	1	Nut
②92210B	92210-7027	4	Nut (M8)
②130	130B0610	1	Bolt-Flanged (6X10)

Ref	Part No.	Qty.	Description
②130A	130B0816	3	Bolt-Flanged (8X16)
②220	220B0614	2	Screw-Pan, Cross (6X14)
②233	233B0416	1	Screw (4X16)
②311	311B0400	1	Nut-Hex (4Mm)
②461	461F0800	4	Washer-Spring (8Mm)
②670	670B2010	1	O-Ring (10Mm)

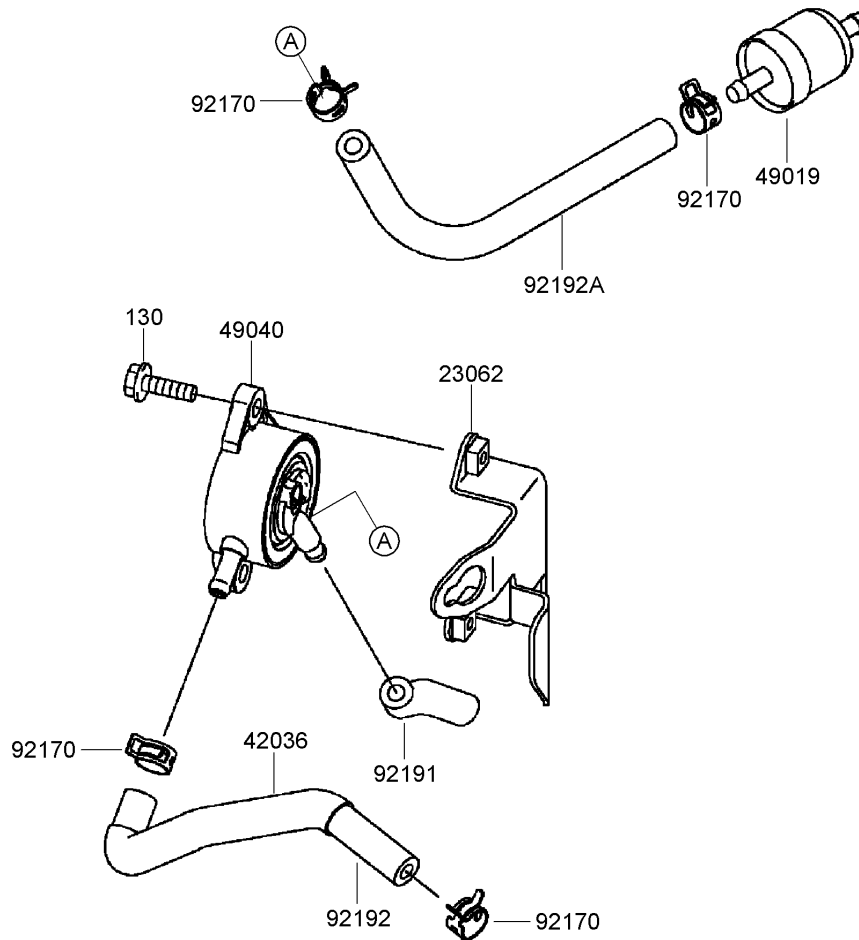

## Fuel Tank and Valve Assembly Kawasaki FH430V-AS35

Ref	Part No.	Qty.	Description
② 23062	23062-7004-9H	1	Bracket
② 42036	42036-7012	1	Sleeve
② 49019	49019-7001	1	Filter-Fuel
② 49040	49040-7001	1	Pump-Fuel
② 92170	92170-2088	4	Clamp
② 92191	92191-7002	1	Tube
② 92192	92192-7035	1	Tube (6.35X12.7X170)
② 92192A	92192-7037	1	Tube (6.35X12.7X160)
② 130	130B0620	2	Bolt-Flanged (6X20)

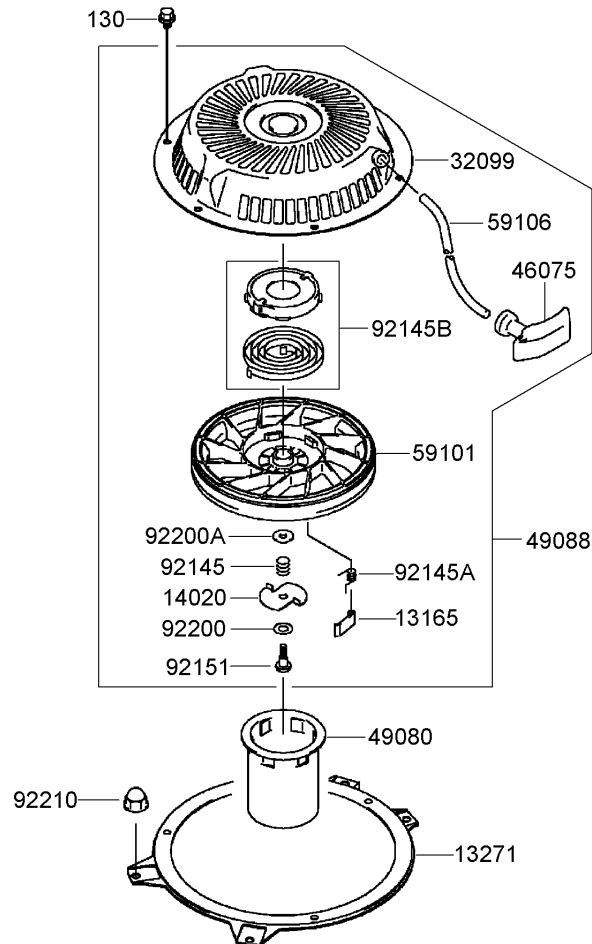

## Starter Assembly Kawasaki FH430V-AS35

Ref	Part No.	Qty.	Description				
② 13165	13165-7001	2	Pawl-Starter, Recoil				
② 13271	13271-7003-9H	1	Plate				
② 14020	14020-7001	1	Retainer				
② 32099	32099-7002	1	Case-Starter, Recoil				
② 46075	46075-7001	1	Grip-Starter, Recoil				
② 49080	49080-7001	1	Pulley-Starting				
② 49088	49088-7013	1	Starter-Recoil				
② 59101	59101-7001	1	Reel-Starter, Recoil				
② 59106	59106-7005	1	Rope				
② 92145	92145-7006	1	Spring				
② 92145A	92145-7007	2	Spring				
② 92145B	92145-7008	1	Spring				
② 92151	92151-7008	1	Bolt				
② 92200	92200-7004	1	Washer				
② 92200A	92200-7005	1	Washer				
② 92210	92210-0003	4	Nut				
② 130	130B0608	3	Bolt-Flanged (6X8)				



**Attachments and Accessories**

**For 30092 - Commercial Walk-Behind Mower, Floating Deck T-Bar Gear with 32in Cutting Unit**

Product Name	Model/Part
Bag Kit .....	30124

# NOTES

# NOTES

# NOTES

