



# Commercial Walk-Behind Mower Fixed Deck T-Bar Gear with 40in TURBO FORCE® Cutting Unit

Model No. 30696 - 290000001 and up.

## Parts Catalog

### Ordering Replacement Parts

To order replacement parts, please supply the part number, the quantity, and the description of each part desired.

### Understanding Reference Numbers

Each Identified part in an illustration has a reference number. The reference number for a part also appears in the parts list, along with other information about the part.

This catalog uses two special reference number formats, one to indicate parts in a service assembly and another to indicate the quantity of a given part in an illustration.

### Service Assembly Reference Numbers

Parts in service assemblies have reference numbers in the form a:b. The a represents the reference number of the entire service assembly and the b represents a sequential number unique to each part within the service assembly.

For example, a wheel assembly might be identified by reference number 6, the tire by 6:1, the valve by 6:2, and the wheel by 6:3. When you order the assembly identified by reference number 6, you receive all parts identified by reference numbers 6:1, 6:2, and 6:3. However, you may also order any part individually. Reference numbers of this type appear in illustrations and in part lists.

### Reference Numbers Indicating Quantity

In an illustration, if a reference number indicates more than one part, the reference number has the form nX y. The n represents the quantity of the part, the X is the multiplication symbol, and the y represents the reference number.

For example, in an illustration, the reference number 2X 37 means that two of the parts identified by reference number 37 are indicated.

# Contents

Description	Page	Description	Page
Engine and Fuel Tank Assembly	..... 3	Lubrication Equipment Assembly Kawasaki FH430V-CS25	..... 17
Transmission Drive Assembly	..... 4	Cooling Equipment Assembly Kawasaki FH430V-CS25	..... 18
Drive Wheel and Brake Assembly	..... 6	Electric Equipment Assembly Kawasaki FH430V-CS25	..... 19
Handle and Control Assembly	..... 7	Control Equipment Assembly Kawasaki FH430V-CS25	..... 20
Deck Assembly	..... 8	Carburetor Assembly Kawasaki FH430V-CS25	..... 21
Deck Assembly No. 110-4908	..... 9	Air Filter and Muffler Assembly Kawasaki FH430V-CS25	..... 22
Deflector Assembly No. 110-0790	..... 10	Fuel Tank and Valve Assembly Kawasaki FH430V-CS25	..... 23
Sheave, Spindle and Blade Assembly	..... 11	Starter Assembly Kawasaki FH430V-CS25	..... 24
Idler Assembly	..... 12	Label Assembly Kawasaki FH430V-CS25	..... 25
Caster Assembly	..... 13	Attachments and Accessories List	..... 26
Cylinder and Crankcase Assembly Kawasaki FH430V-CS25	..... 14		
Piston and Crankshaft Assembly Kawasaki FH430V-CS25	..... 15		
Valve and Camshaft Assembly Kawasaki FH430V-CS25	..... 16		

## Part Description Abbreviations

Part descriptions in this catalog may include the following abbreviations.

AR. .... as required	HWHTF. .... hex washer head thread forming
ASM. .... assembly	HYD. .... hydraulic
BBC. .... blade brake clutch	LH. .... left hand
CARR. .... carriage	NI. .... nylon insert
CCW. .... counter clock wise	NPTF. .... national pipe thread fine
CW. .... clockwise	PFH. .... phillips flat head
DEG. .... degrees	PPH. .... phillips pan head
ECM. .... electronic control module	PPHTF. .... phillips pan head thread forming
EXT. .... external	PRH. .... phillips round head
FH. .... flat head	PTH. .... phillips truss head
GA. .... gauge	PTO. .... power-take-off
HD. .... heavy-duty	RH. .... right hand
HF. .... hex flange	ROPS. .... roll-over protection system
HH. .... hex head	SFH. .... slotted fillister head
HHF. .... hex head flange	SHH. .... slotted hex head
HHFTF. .... hex head flange thread forming	SHWH. .... slotted hex washer head
HJ. .... hex jam	SPH. .... slotted pan head
HLH. .... hex lag head	SQH. .... square head
HOC. .... height-of-cut	SRH. .... slotted round head
HSBH. .... hex socket button head	STD. .... standard
HSFH. .... hex socket flat head	TAP. .... self tapping
HSH. .... hex socket head	TTH. .... torx truss head
HWH. .... hex washer head	

## Footnotes

- ❶ Not serviced separately
- ❷ Obtain parts from Peerless Transmissions (model 700-070A)
- ❸ Obtain parts from [www.kawpowerepc.com](http://www.kawpowerepc.com)

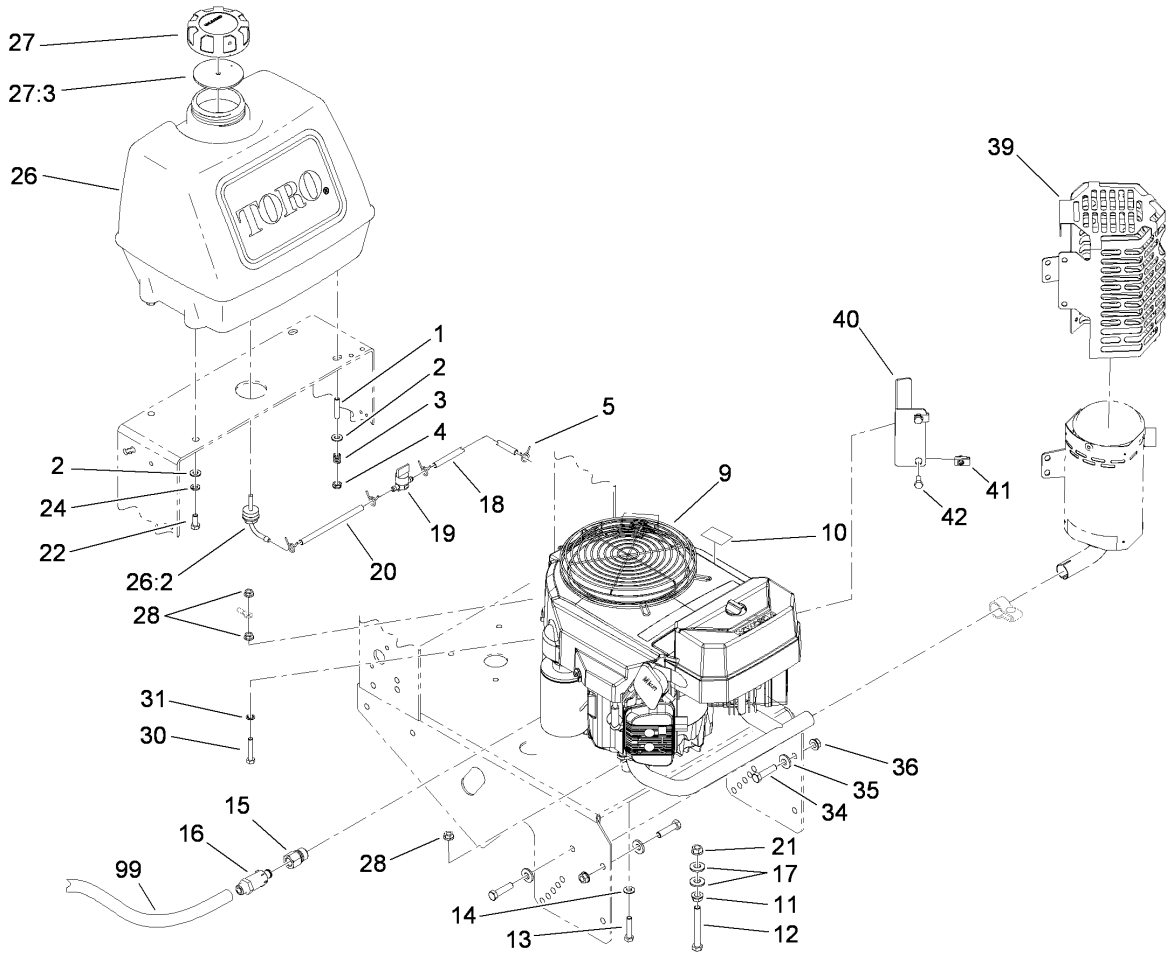

## Engine and Fuel Tank Assembly

Ref	Part No.	Qty.	Description
1	1-633023	2	Stud
2	3256-23	4	Washer-Flat
3	1-633349	2	Spring-Tank, Fuel
4	3296-47	2	Nut-Lock, NI
5	1-303077	4	Clamp
① 99		1	Engine-Kawasaki, FH430V-Cs25
10	106-0699	1	Decal-Warning
11	3290-357	1	Nut-HHF, Whiz
12	323-14	1	Screw-HH
13	322-7	3	Screw-HH
14	1-303334	3	Washer-Spring
15	103-1966	1	Adapter
16	92-6877	1	Valve-Drain, Oil
17	98-5975	2	Washer-Belleville
18	109-0293	1	Hose-Fuel
19	1-603770	1	Valve-Fuel
20	109-0306	1	Hose-Fuel
21	32128-21	1	Nut-HF
22	322-3	2	Screw-HH
24	1-805005	2	Washer-Lock
26	106-0730	1	Fuel Tank ASM
26:2	103-2605	1	Fitting-Fuel, Bulkhead
27	88-3980	1	Gas Cap ASM
27:3	88-4010	1	Gasket-Cap, Gas

Ref	Part No.	Qty.	Description
28	32128-20	5	Nut-HF
30	322-9	1	Screw-HH
31	3254-2	1	Washer-Lock, Internal
34	323-8	8	Screw-HH
35	98-5975	8	Washer-Belleville
36	3290-357	8	Nut-HHF, Whiz
39	115-4150-03	1	Muffler Shield ASM
40	115-4154-03	1	Bracket-Muffler
41	94-2413	4	U-Nut
42	322-3	4	Screw-HH
99	103-1964	1	Hose-Drain, Oil

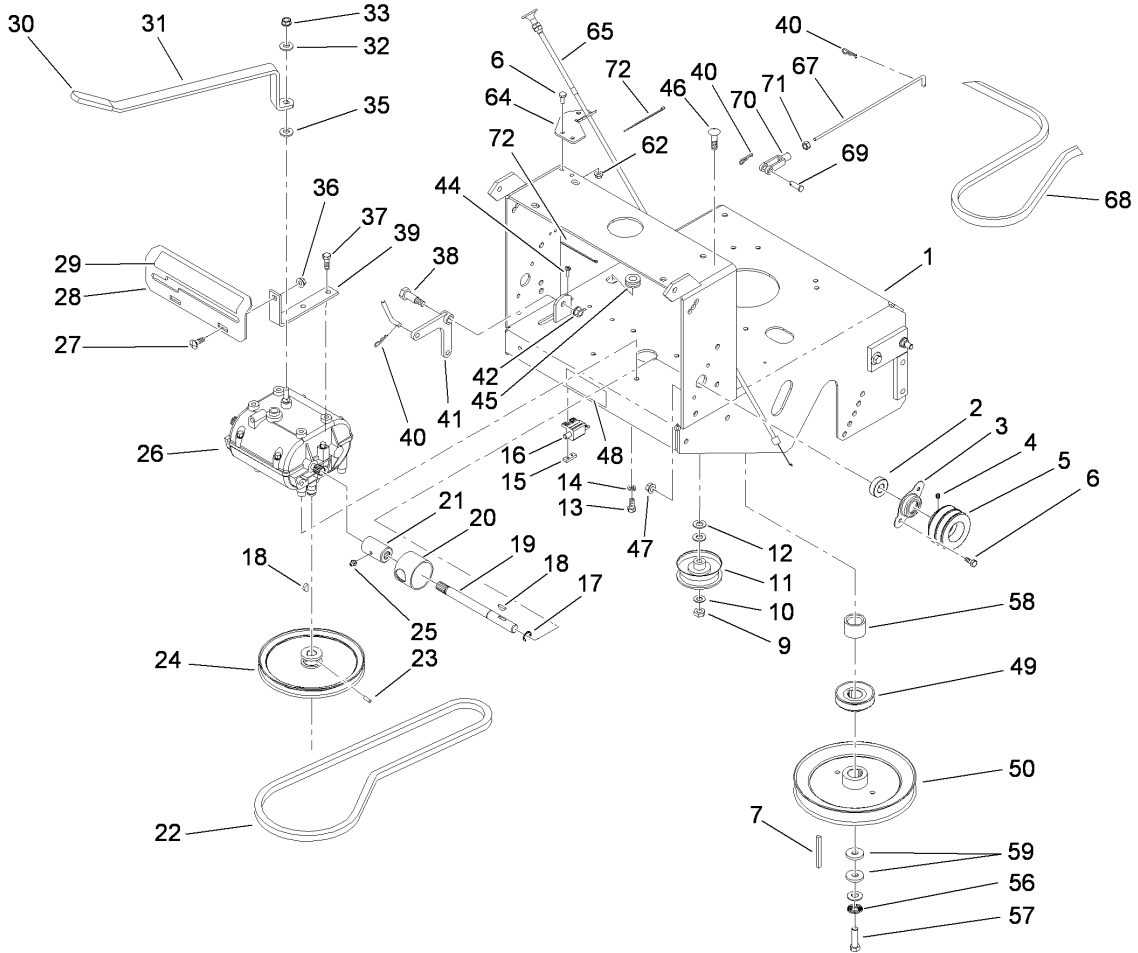

## Transmission Drive Assembly

Ref	Part No.	Qty.	Description
1	103-9897-01	1	Deck-Engine
2	1-323252	2	Bearing-Shaft
3	1-323254	2	Flange-Output
4	1-803310	2	Screw-Set
5	103-6511	2	Sheave-Transmission
6	321-3	6	Screw-HH
7	103-4177	1	Key
9	3296-39	1	Nut-Lock, NI
10	3256-24	1	Washer-Flat
11	1-323285	1	Idler-Drive, Transmission
12	3256-5	2	Washer-Flat
13	322-3	4	Screw-HH
14	1-805005	4	Washer-Lock
15	1-633181	1	Plate-Tapped
16	1-513152	1	Switch-Closed, Normally
17	32151-62	2	Ring-Retaining
18	3257-5	3	Key-Woodruff
19	1-323502	2	Shaft-Transmission
20	51-4220	2	Guard-Coupler
21	1-323680	2	Coupler
22	1-323630	1	V-Belt
23	3245-41	2	Screw-HSH
24	1-323278	1	Sheave-Transmission
25	302-19	2	Fitting-Grease

Ref	Part No.	Qty.	Description
26	1-323500	1	Transmission
27	3230-1	2	Bolt-CARR
28	1-323387-03	1	Plate-Shift
29	98-3256	1	Decal-Speed, Ground
30	1-303020	1	Grip-Lever
31	98-3274-03	1	Lever-Shift
32	98-5975	1	Washer-Belleville
33	3296-6	1	Nut-Lock
35	1-323379	1	Washer
36	32128-20	2	Nut-HF
37	9264964	4	Screw-HWH, Thread Cut
38	1-603403	1	Bolt-Shoulder
39	1-323389-03	2	Bracket-Plate, Shift
40	1-806003	3	Pin-Cotter, Hair
41	1-303186	1	Bellcrank
42	32128-21	1	Nut-HF
44	3290-500	2	Screw-PPH
45	1-543296	1	Grommet
46	3231-6	1	Screw-CARR
47	3296-42	4	Nut-Lock, NI
48	98-0776	1	Decal-Caution
49	103-1666	1	Sheave-Transmission
50	110-0504	1	Pulley ASM
56	1-603610	2	Washer-Spring



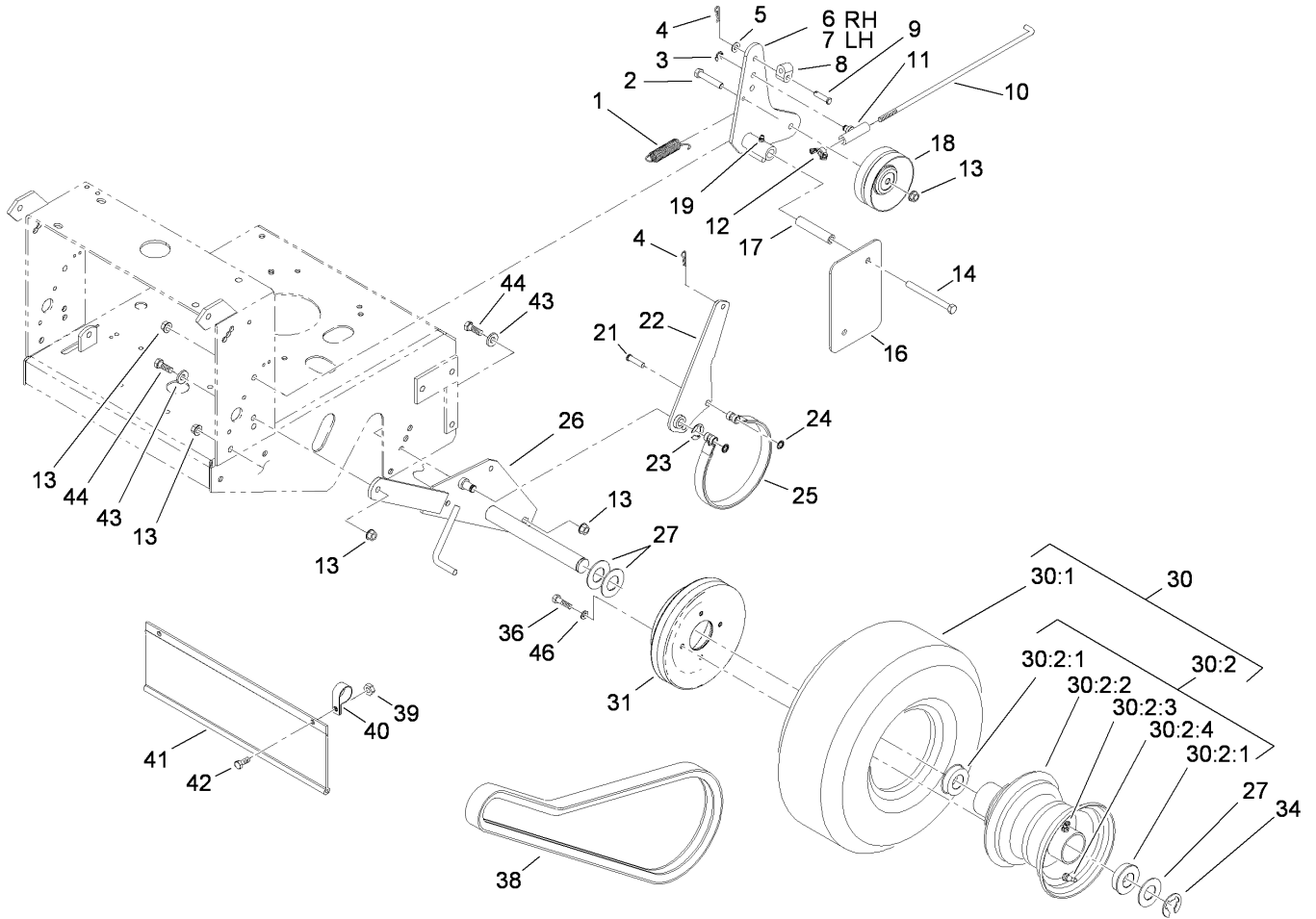

## Drive Wheel and Brake Assembly

Ref	Part No.	Qty.	Description
1	98-3273	2	Spring-Extension
2	323-10	2	Screw-HH
3	32151-47	2	Ring-Retaining
4	1-806003	4	Pin-Cotter, Hair
5	3256-23	2	Washer-Flat
6	110-4925-03	1	RH Idler Arm ASM
7	110-4926-03	1	LH Idler Arm ASM
8	74-0521	2	Fitting-Rod
9	283-6	2	Pin-Clevis
10	1-323296	2	Rod-Brake
11	110-5866	2	Swivel-Brake
12	1-513959	2	Wingnut-Nylock
13	3290-357	10	Nut-HHF, Whiz
14	323-16	4	Screw-HH
16	98-5131-01	2	Shield-Wheel, Drive
17	1-323694	4	Spacer-Shield
18	1-323634	2	Idler-Drive, Wheel
19	302-19	2	Fitting-Grease
21	1-323307	4	Pin-Clevis
22	1-322209-03	2	Arm-Brake
23	32120-47	2	Ring-Retaining, External
24	1-803051	4	Nut-Push
25	1-323595	2	Band-Brake
26	1-322212-03	1	Axle ASM

Ref	Part No.	Qty.	Description
27	1-543436	8	Washer-Spacer
27	1-523157	6	Washer-Spacer
30	1-323719	2	Wheel And Tire ASM
30:1	1-323720	1	Tire-Turfmaster
30:2	1-323328	1	Wheel And Hub ASM
30:2:1	1-323329	2	Bearing-Flanged
30:2:2		1	Rim ASM
30:2:3		1	Fitting-Grease
30:2:4		1	Stem-Valve
31	109-4359	2	Drum And Sheave ASM
34	1-808519	2	Ring-Snap
36	322-5	8	Screw-HH
38	1-323631	2	V-Belt
39	3296-29	2	Nut-Lock, NI
40	2412-104	2	R-Clamp
41	98-3259	1	Shield-Trailing
42	322-3	2	Screw-HH
43	98-5975	4	Washer-Belleville
44	323-6	4	Screw-HH
46	1-805005	8	Washer-Lock

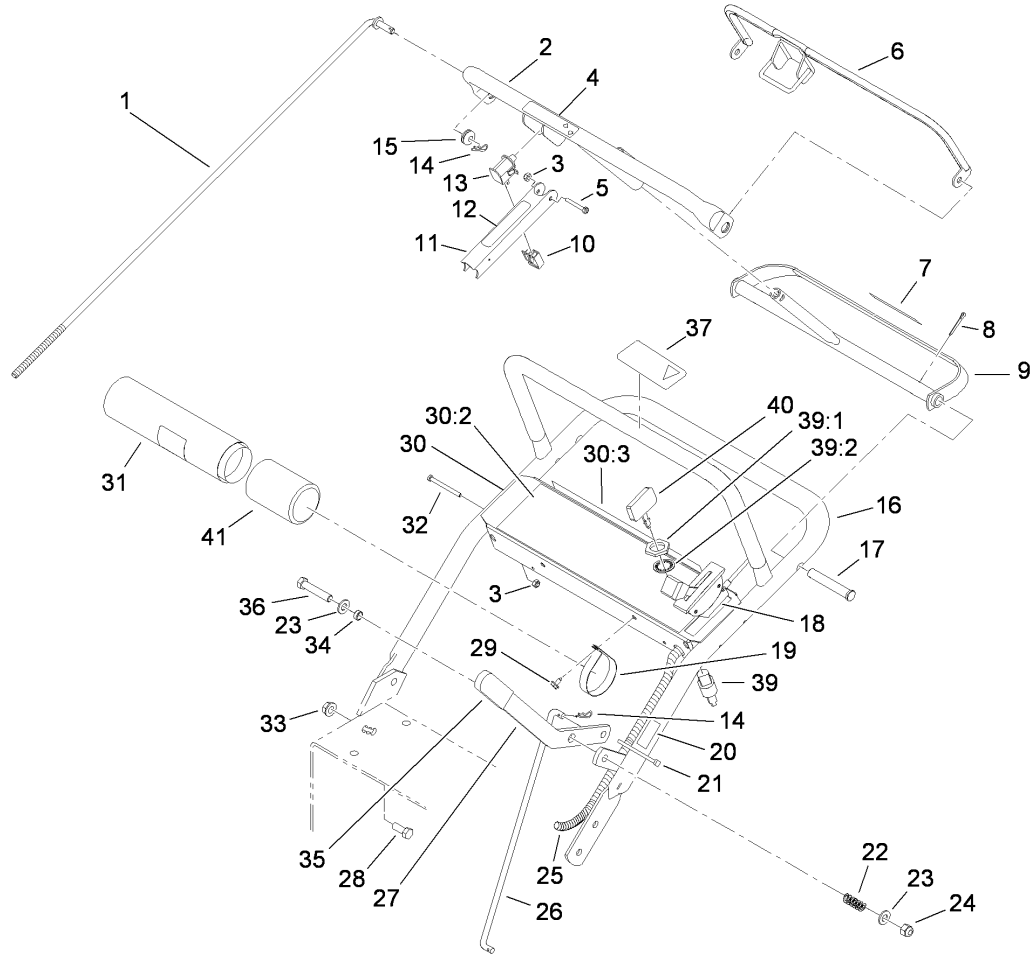

## Handle and Control Assembly

Ref	Part No.	Qty.	Description
1	98-3282	2	Rod-Control
2	95-5522-03	1	Control Bar ASM
3	3296-2	5	Nut-Lock, NI
4	82-2290	1	Decal
5	32105-1	1	Screw-SHH
6	82-7680-03	1	Bail ASM
7	82-2280	1	Decal
8	3272-11	2	Pin-Cotter
9	99-8501-03	1	Control-Pivot
10	218-595	1	Connector-Body
11	98-3261-03	1	Lever-Brake, Parking
12	98-3266	1	Decal
13	740275	1	Switch-Seat
14	1-806003	3	Pin-Cotter, Hair
15	237-141	2	Grommet-Rubber
16	98-3267-03	1	Upper Handle ASM
17	283-55	2	Pin-Clevis
18	114-3465	1	Cable-Throttle
19	2412-120	2	R-Clamp
20	95-5537	1	Decal-Engage, Deck
21	1-303335	1	Tie-Plastic
22	1-303160	1	Spring-Compression
23	3256-24	2	Washer-Flat
24	3296-39	1	Nut-Lock, NI

Ref	Part No.	Qty.	Description
25	106-0678	1	Harness-Wire
26	98-3279	1	Linkage-Drive, Blade
27	98-3287-03	1	Lever-Engagement, Blade
28	3234-11	4	Screw-HHF
29	32104-76	2	Screw
30	110-6905	1	Control Panel ASM
30:2	110-6916	1	Decal-Panel, Control
30:3	105-0884	1	Decal-Danger
31	104-7050	1	Tube-Manual
32	32105-14	4	Screw-SHH
33	32128-21	4	Nut-HF
34	99-8509	1	Spacer
35	1-303020	1	Grip-Lever
36	323-10	1	Screw-HH
37	98-4387	1	Decal-Protection, Ear
39	29-5560	1	Switch-On / Off
39:1	218-461	1	Nut-HH
39:2	3254-5	1	Washer-Tooth
40	63-8360	1	Key-Ignition
41	104-7048	1	Cap-Housing

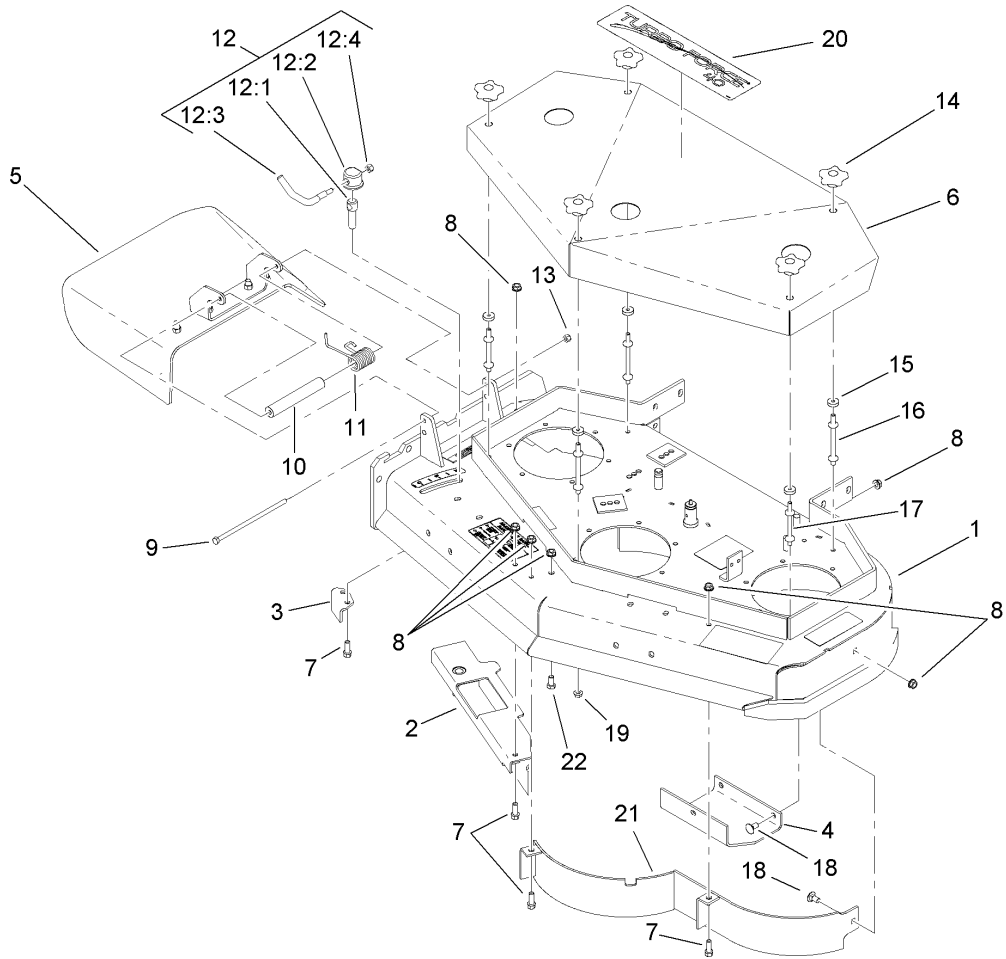

## Deck Assembly

Ref	Part No.	Qty.	Description
1	110-4908	1	Deck ASM
2	110-0795-03	1	Baffle Adjust ASM
3	108-7273-01	1	Baffle-Discharge
4	108-7282-01	1	Plate-Skid
5	110-0790	1	Deflector ASM
6	110-2034-01	1	Cover-Deck
7	92-1624	5	Screw-HWH
8	3290-357	12	Nut-HHF, Whiz
9	322-50	1	Screw-HH
10	105-4622	1	Spacer
11	104-8554	1	Spring-Torsion
12	107-1664	1	Lever ASM
12:1	106-3239	1	Screw-Lock
12:2	107-1644	1	Cap-Lock
12:3	106-3241	1	Lever-Lock
12:4	3296-29	1	Nut-Lock, NI
13	3296-29	1	Nut-Lock, NI
14	106-4161	5	Knob-Handle
15	1-323417	5	Washer
16	1-303536	3	Stud-Shield, Belt (Long)
17	1-303537	2	Stud-Shield, Belt (Short)
18	3231-1	4	Screw-CARR
19	32128-20	5	Nut-HF
20	112-9711	1	Decal

Ref	Part No.	Qty.	Description
21	110-6910-03	1	Baffle ASM
22	323-4	3	Screw-HH

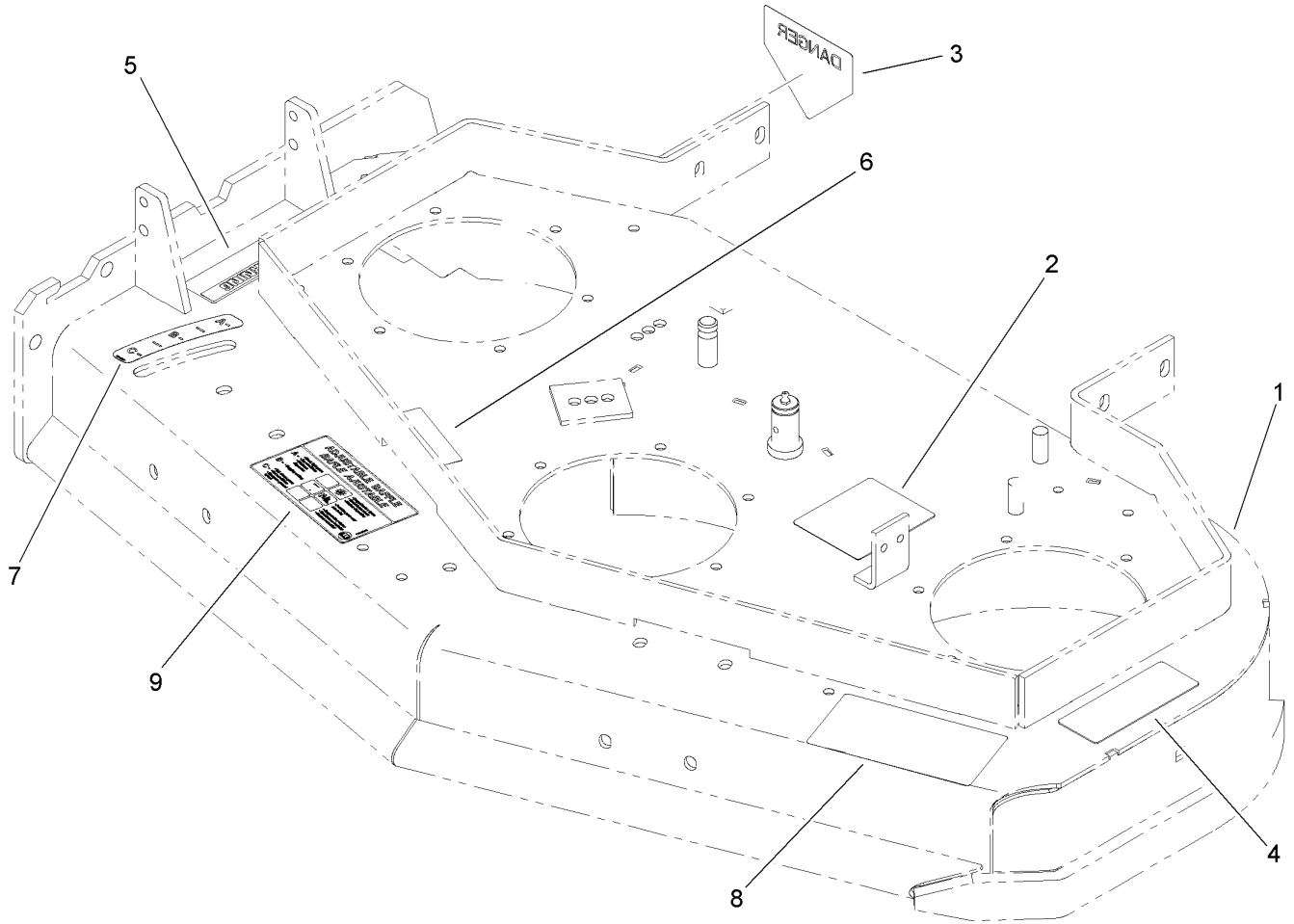

## Deck Assembly No. 110-4908

Ref	Part No.	Qty.	Description
❶ 1		1	40 Inch Deck ASM
2	99-3943	1	Decal-Routing, Belt
3	43-8480	1	Decal-Danger
4	98-5130	1	Decal-Torque, Bolt
5	104-8569	1	Decal-Warning
6	98-5954	2	Decal-Cover, Missing
7	110-2067	1	Decal-Setting, Baffle
8	66-1340	1	Decal-Danger, Thrown Object
9	110-2068	1	Decal-Adjustment, Baffle

Ref	Part No.	Qty.	Description

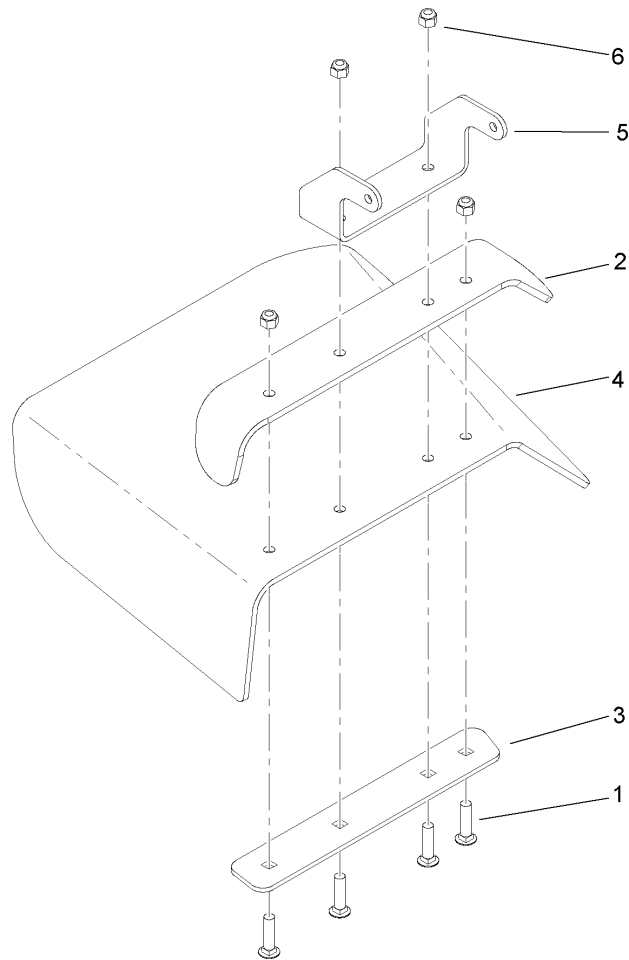

### Deflector Assembly No. 110-0790

Ref	Part No.	Qty.	Description
1	3231-4	4	Screw-CARR
2	110-0792-01	1	Deflector
3	110-0793-03	1	Strap-Discharge
4	110-0791	1	Deflector-Rubber
5	107-4164-01	1	Bracket-Mounting, Deflector
6	3296-39	4	Nut-Lock, NI

--	--	--	--

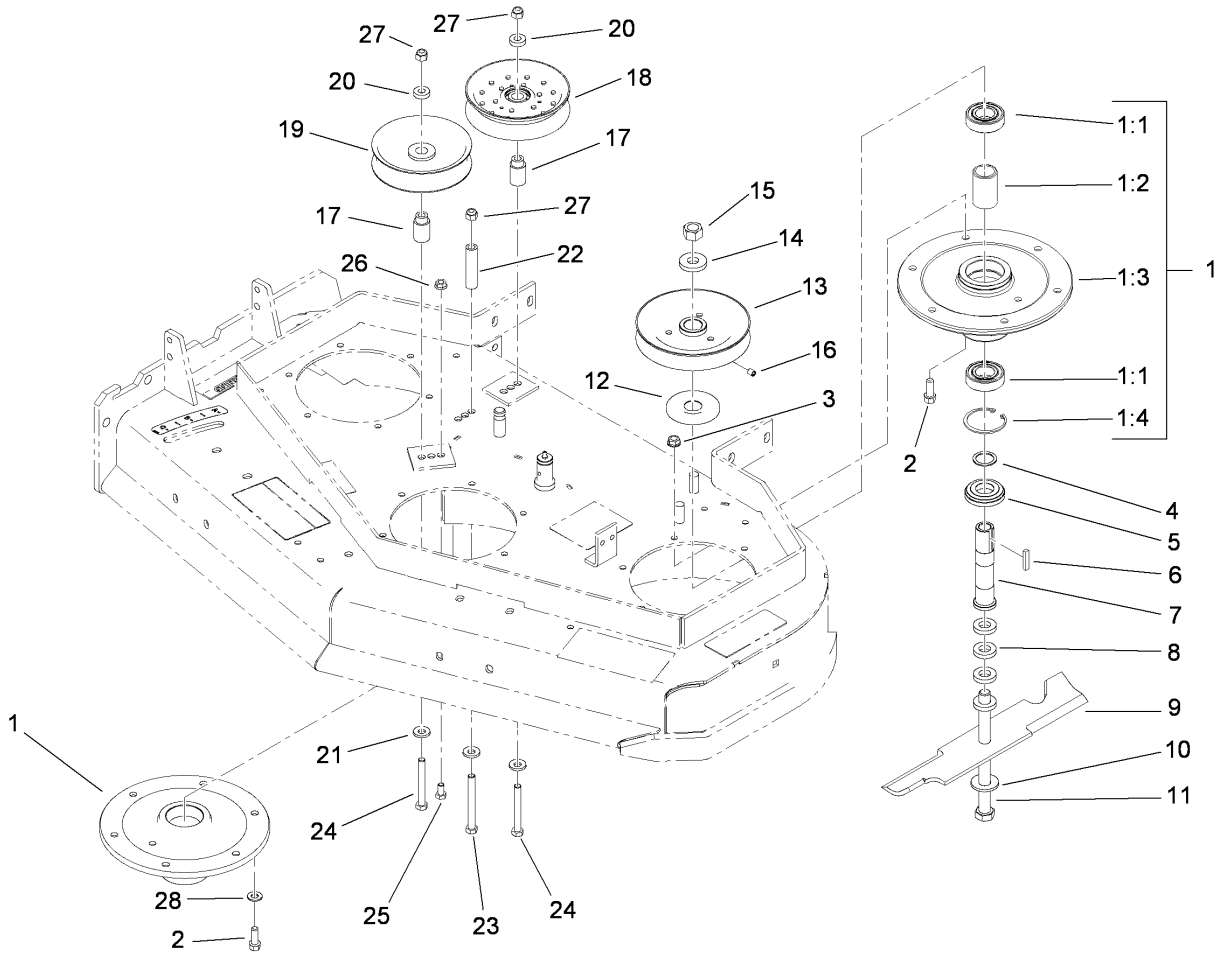

## Sheave, Spindle and Blade Assembly

Ref	Part No.	Qty.	Description
1	108-6697	3	Spindle Housing ASM
1:1	110-2118	2	Bearing
1:2	110-2116	1	Spacer-Bearing
1:3	108-6694	1	Housing-Spindle
1:4	32120-8	1	Ring-Snap
2	92-1624	18	Screw-HWH
3	3290-357	18	Nut-HHF, Whiz
4	110-4888	3	Washer-Spacer
5	103-2535	3	Spacer-Guard, Bottom
6	1-807267	3	Key
7	1-323529	3	Tube-Spindle, Short
8	1-323539	12	Spacer
9	108-4081-03	3	Blade-14 Inch (High Sail)
10	1-513208	3	Washer-Spring
11	1-800861	3	Screw-Cap, HH
12	103-1330	3	Guard-Bearing, Top
13	1-403183	3	Sheave
14	1-323339	3	Washer-Retainer, Sheave
15	3219-6	3	Nut-Hex
16	1-803310	3	Screw-Set
17	1-413113	2	Bushing-Idler
18	1-403186	1	Idler-Pulley, Flat
19	1-613098	1	Pulley-Idler
20	5-0652	2	Spacer

Ref	Part No.	Qty.	Description
21	98-5975	3	Washer-Belleville
22	1-403188	1	Spacer
23	323-15	1	Screw-HH
24	323-14	2	Screw-HH
25	322-2	1	Screw-HH
26	32128-20	1	Nut-HF
27	3296-39	3	Nut-Lock, NI
28	3256-24	1	Washer-Flat

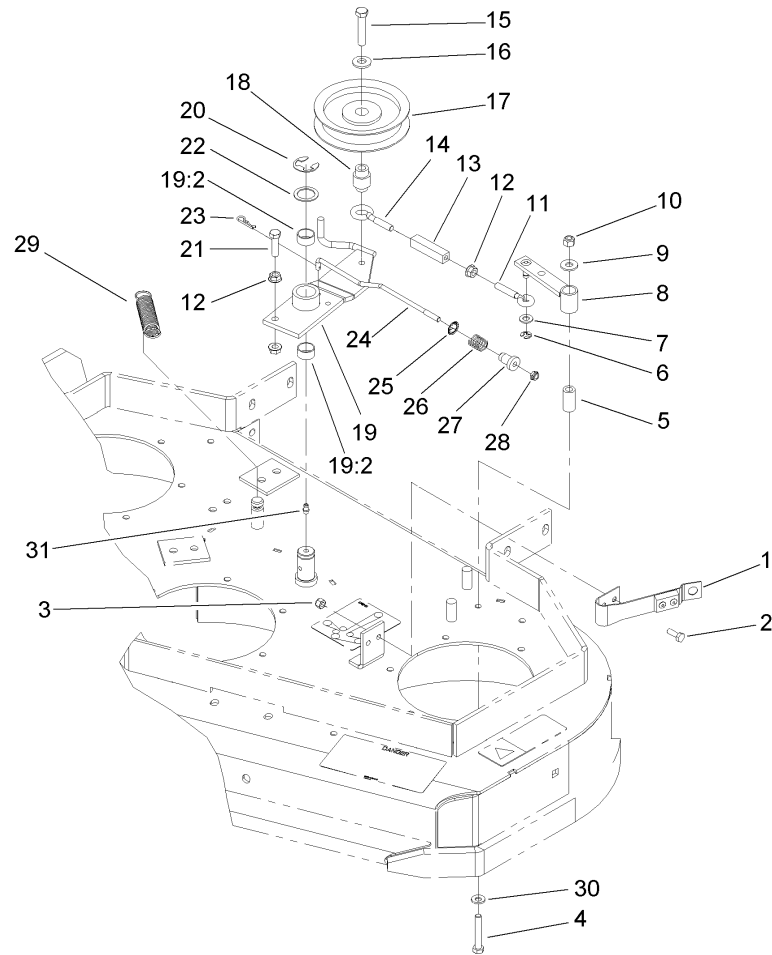

## Idler Assembly

Ref	Part No.	Qty.	Description
1	1-324372	1	Pad And Spring ASM
2	321-4	2	Screw-HH
3	3296-42	2	Nut-Lock, NI
4	322-10	1	Screw-HH
5	1-403179	1	Tube-Pivot
6	32120-35	1	Ring-Retaining, EXT
7	3256-23	1	Washer-Flat
8	1-322235	1	Arm-Assist
9	3256-3	1	Washer-Flat
10	3296-29	1	Nut-Lock, NI
11	1-303238	1	Eyebolt-Thread, RH
12	32128-20	3	Nut-HF
13	1-303236	1	Body-Turnbuckle
14	1-303348	1	Eyebolt-Thread, LH
15	702809	1	Screw-Cap
16	98-5975	1	Washer-Belleville
17	1-603843	1	Pulley-Idler
18	1-303434	1	Bushing-Engagement
19	103-3600	1	Idler Arm ASM
19:2	1-323729	2	Sleeve-Bearing
20	32151-103	1	Ring-Retaining, EXT
21	322-6	1	Screw-HH
22	1-303352	1	Washer-Spindle
23	1-806003	3	Pin-Cotter, Hair

Ref	Part No.	Qty.	Description
24	110-2051	1	Rod-Brake
25	1-323748	1	Ring-Push On
26	1-323747	1	Spring-Compression
27	1-323746	1	Spacer-Flanged
28	3296-56	1	Nut-Lock, NI
29	1-323071	1	Spring-Extension
30	1-303334	1	Washer-Spring
31	302-19	2	Fitting-Grease

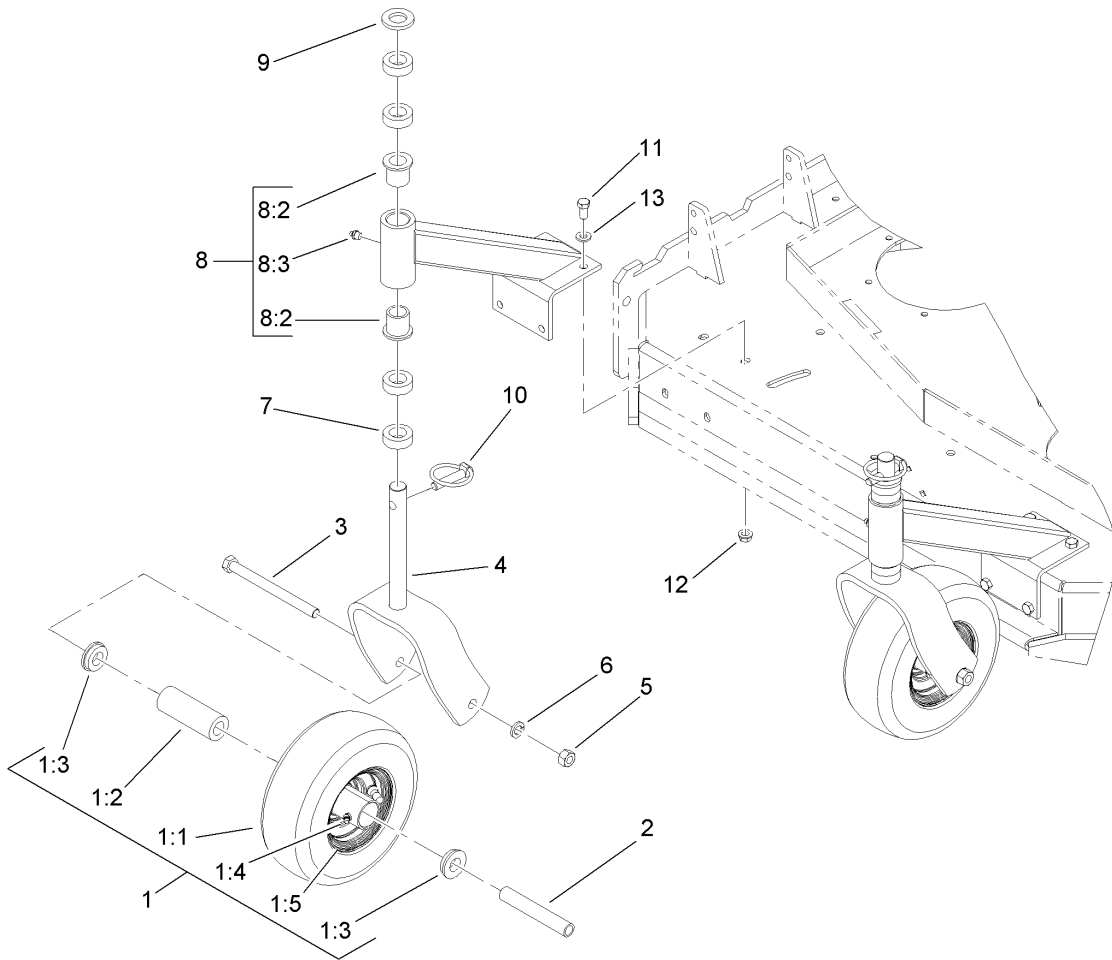

### Caster Assembly

Ref	Part No.	Qty.	Description
1	110-5023	2	Wheel And Tire ASM
1:1		1	Tire
1:2	1-513809	1	Bearing
1:3	1-513810	2	Bushing
1:4	302-61	1	Zerk
1:5		1	Wheel
2	1-513547	2	Spacer
3	325-20	2	Screw-HH
4	1-322145-01	2	Fork
5	3217-9	2	Nut-HH
6	3253-7	2	Washer-Lock
7	1-303314	8	Spacer-Caster
8	110-2130	2	Support ASM
8:2	1-303514	2	Bearing-Flanged
8:3	302-52	1	Fitting-Grease
9	1-513338	2	Washer-Flat
10	1-809020	2	Pin
11	323-6	8	Screw-HH
12	3290-357	8	Nut-HHF, Whiz
13	3256-24	8	Washer-Flat

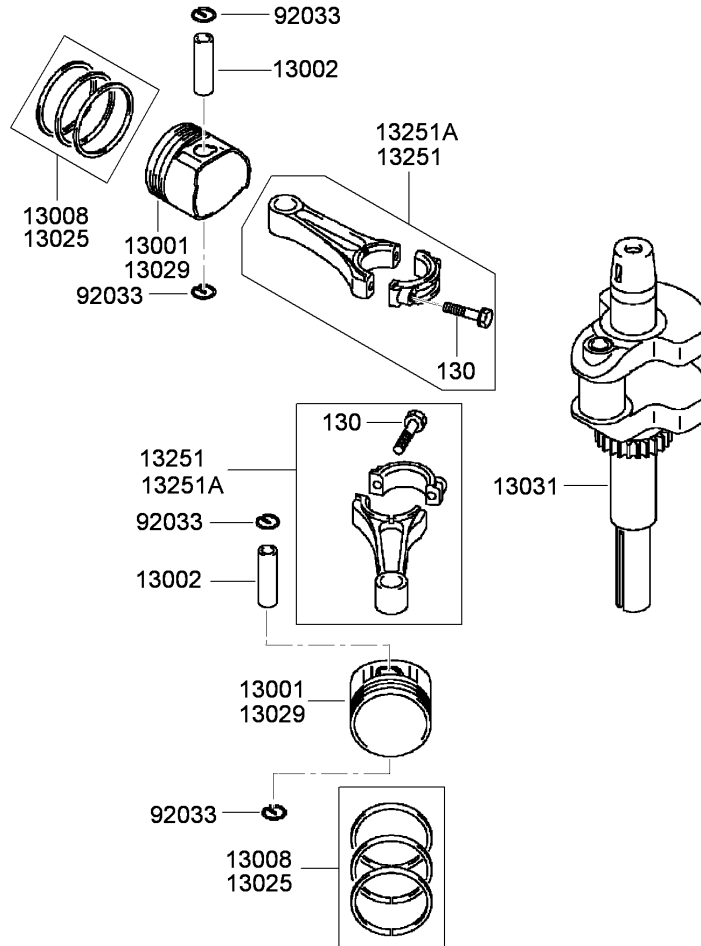

## Piston and Crankshaft Assembly Kawasaki FH430V-CS25

Ref	Part No.	Qty.	Description
③ 130	130G0630	4	Bolt-Flanged (6X30)
③ 13001	13001-7009	2	Piston-Engine
③ 13002	13002-7001	2	Pin-Piston
③ 13008	13008-7001	2	Piston Ring Set
③ 13025	13025-7003	1	Piston Ring Set (L 0.50)
③ 13029	13029-7005	1	Piston-Engine (L 0.50)
③ 13031	13031-7033	1	Crankshaft
③ 13251	13251-7007	2	Connecting Rod ASM
③ 13251A	13251-7008	2	Connecting Rod ASM (0.50)
③ 92033	92033-7005	4	Ring-Snap

--	--	--	--

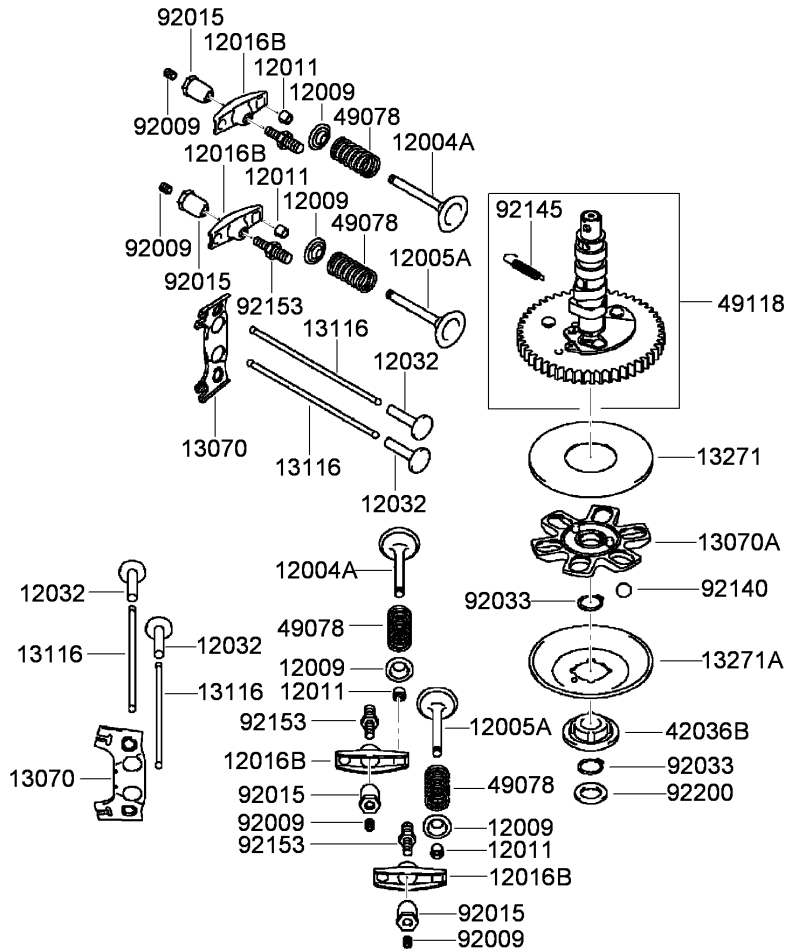

## Valve and Camshaft Assembly Kawasaki FH430V-CS25

Ref	Part No.	Qty.	Description
③ 12004A	12004-7005	2	Valve-Intake
③ 12005A	12005-7006	2	Valve-Exhaust
③ 12009	12009-7001	4	Retainer-Spring, Valve
③ 12011	12011-2056	8	Collet
③ 12016B	12016-7008	4	Arm-Rocker
③ 12032	12032-7001	4	Tappet
③ 13070	13070-7001	2	Guide
③ 13070A	13070-7004	1	Guide
③ 13116	13116-2057	4	Rod-Push
③ 13271	13271-7007	1	Plate
③ 13271A	13271-7021	1	Plate-Governor
③ 42036B	42036-7010	1	Sleeve
③ 49078	49078-7001	4	Spring-Valve, Engine
③ 49118	49118-7009	1	Camshaft
③ 92009	92009-2341	4	Screw
③ 92015	92015-2253	4	Nut
③ 92033	92033-7001	2	Ring-Snap
③ 92140	92140-7002	6	Ball
③ 92145	92145-7001	1	Spring
③ 92153	92153-7019	4	Bolt
③ 92200	92200-7001	1	Washer

--	--	--	--



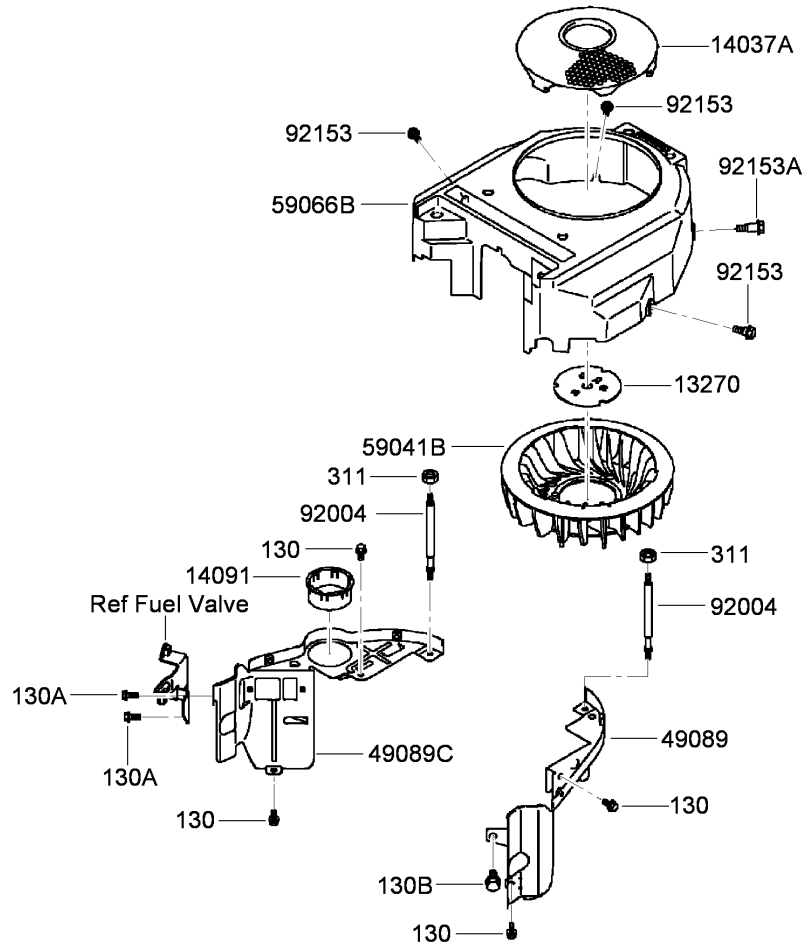

## Cooling Equipment Assembly Kawasaki FH430V-CS25

Ref	Part No.	Qty.	Description
③ 130	130B0612	4	Bolt-Flanged (6X12)
③ 130A	130B0616	2	Bolt-Flanged (6X16)
③ 130B	130B0816	1	Bolt-Flanged (8X16)
③ 311	311F0600	2	Nut-Hex (6Mm)
③ 13270	13270-7007	1	Plate
③ 14037A	14037-7025-9H	1	Screen
③ 14091	14091-7009	1	Cover
③ 49089	49089-7044	1	Shroud-Engine
③ 49089C	49089-7061	1	Shroud-Engine
③ 59041B	59041-7012	1	Fan
③ 59066B	59066-7036	1	Housing-Fan
③ 92004	92004-7007	2	Stud
③ 92153	92153-7007	3	Bolt
③ 92153A	92153-7008	1	Bolt

--	--	--	--

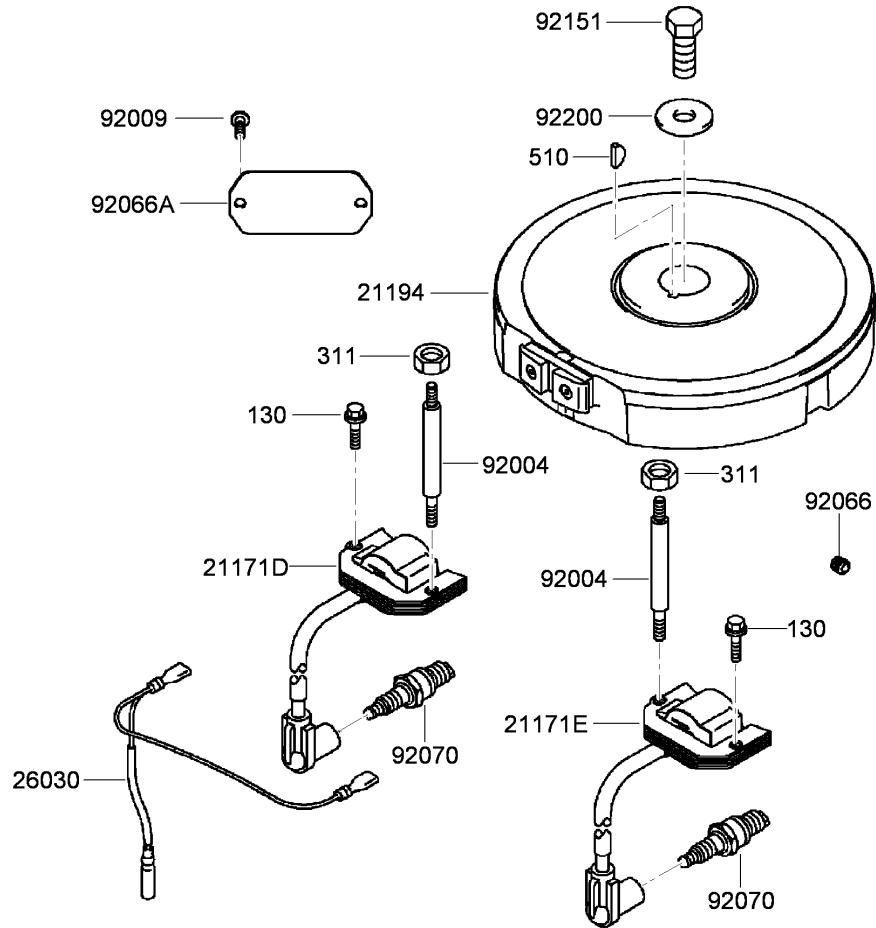

## Electric Equipment Assembly Kawasaki FH430V-CS25

Ref	Part No.	Qty.	Description
③130	130B0620	2	Bolt-Flanged (6X20)
③311	311F0600	2	Nut-Hex (6Mm)
③510	510A5100	1	Key-Woodruff
③21171D	21171-7026	1	Ignition Coil ASM
③21171E	21171-7027	1	Ignition Coil ASM
③21194	21194-7013	1	Flywheel
③26030	26030-7001	1	Harness
③92004	92004-7008	2	Stud
③92009	92009-2308	2	Screw
③92066	92066-7002	1	Plug
③92066A	92066-7005	1	Plug
③92070	92070-7003	2	Spark Plug (R C J 8 Y, Solid)
③92151	92151-2097	1	Bolt (12X30)
③92200	92200-7002	1	Washer

--	--	--	--



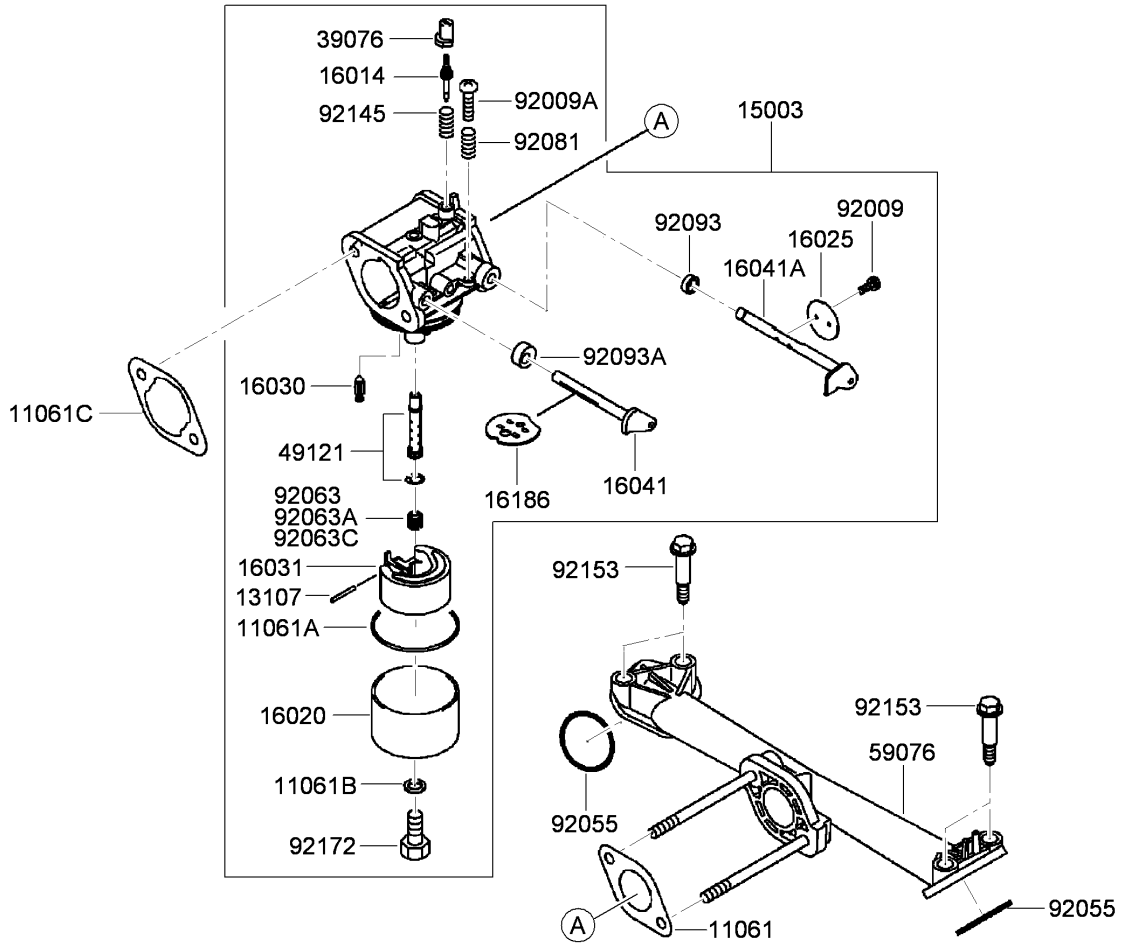

## Carburetor Assembly Kawasaki FH430V-CS25

Ref	Part No.	Qty.	Description
③ 11061	11061-7004	1	Gasket-Insulator
③ 11061A	11061-7009	1	Gasket-Chamber
③ 11061B	11061-7010	1	Gasket-Screw
③ 11061C	11061-7018	1	Gasket-Cleaner, Air
③ 13107	13107-7018	1	Shaft
③ 15003	15003-7061	1	Carburetor ASM
③ 16014	16014-7002	1	Screw-Pilot, Air
③ 16020	16020-7003	1	Chamber-Float
③ 16025	16025-7006	1	Valve-Throttle
③ 16030	16030-7003	1	Valve-Float
③ 16031	16031-7002	1	Float
③ 16041	16041-7016	1	Shaft-Choke, Carburetor
③ 16041A	16041-7018	1	Shaft-Throttle, Carburetor
③ 16186	16186-7002	1	Choke Valve ASM
③ 39076	39076-7001	1	Limiter
③ 49121	49121-7001	1	Nozzle-Main
③ 59076	59076-7005	1	Manifold-Intake
③ 92009	92009-2083	2	Screw
③ 92009A	92009-2349	1	Screw
③ 92055	92055-7007	2	O-Ring (I D 31)
③ 92063	92063-7026	1	Jet-Main, No. 88
③ 92063A	92063-7028	1	Jet-Main, No. 85 (3280 Ft)
③ 92063C	92063-7029	1	Jet-Main, No.82 (6560 Ft)
③ 92081	92081-2234	1	Spring

Ref	Part No.	Qty.	Description
③ 92093	92093-2100	1	Seal
③ 92093A	92093-7003	1	Seal
③ 92145	92145-7015	1	Spring
③ 92153	92153-7009	4	Bolt
③ 92172	92172-7002	1	Screw

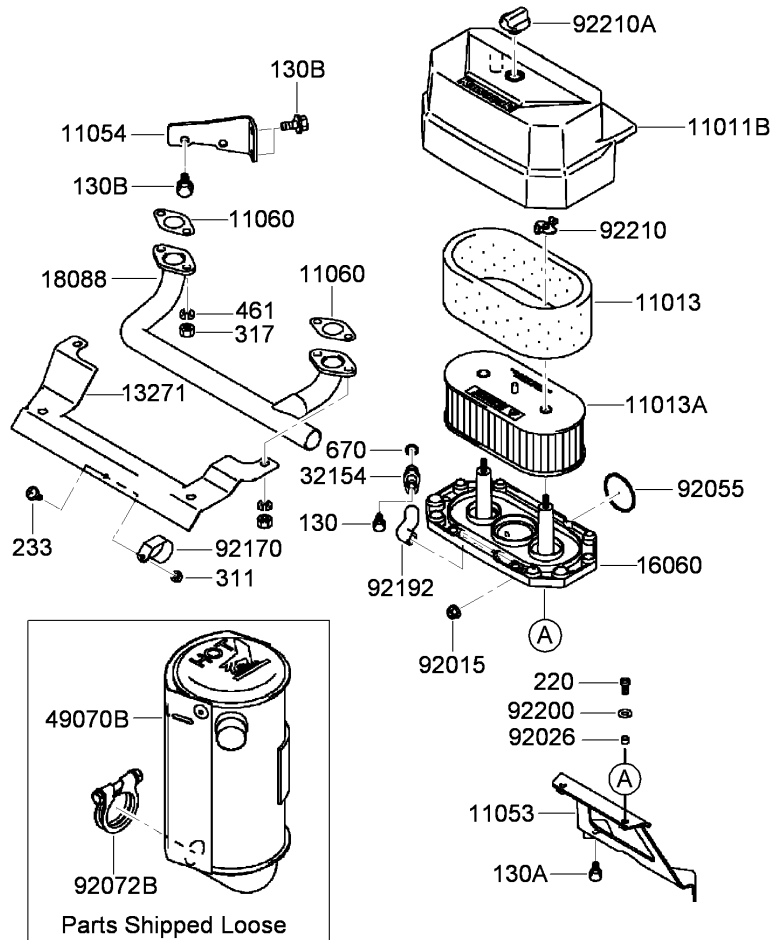

## Air Filter and Muffler Assembly Kawasaki FH430V-CS25

Ref	Part No.	Qty.	Description
● 130	130B0610	1	Bolt-Flanged (6X10)
● 130A	130B0612	2	Bolt-Flanged (6X12)
● 130B	130B0816	3	Bolt-Flanged (8X16)
● 220	220B0614	2	Screw-Pan, Cross (6X14)
● 233	233B0416	1	Screw (4X16)
● 311	311B0400	1	Nut-Hex (4Mm)
● 317	317R0800	4	Nut-Hex, Small (8Mm)
● 461	461F0800	4	Washer-Spring (8Mm)
● 670	670B2010	1	O-Ring (10Mm)
● 11011B	11011-7045	1	Case-Filter, Air
● 11013	11013-7025	1	Element-Filter, Air
● 11013A	11013-7031	1	Element-Filter, Air
● 11053	11053-7022	1	Bracket
● 11054	11054-7002-9H	1	Bracket
● 11060	11060-7021	2	Gasket-Muffler
● 13271	13271-7022	1	Plate
● 16060	16060-7016	1	Pipe-Intake
● 18088	18088-7001	1	Pipe-Exhaust
● 32154	32154-7006	1	Pipe
● 49070B	49070-7021	1	Muffler
● 92015	92015-1193	2	Nut
● 92026	92026-7001	2	Spacer (6.2X7.9X5)
● 92055	92055-7015	1	O-Ring

Ref	Part No.	Qty.	Description
● 92072B	92072-7012	1	Band
● 92170	92170-7002	1	Clamp
● 92192	92192-7010	1	Tube
● 92200	92200-2070	2	Washer
● 92210	92210-7004	2	Nut (M6)
● 92210A	92210-7019	1	Nut

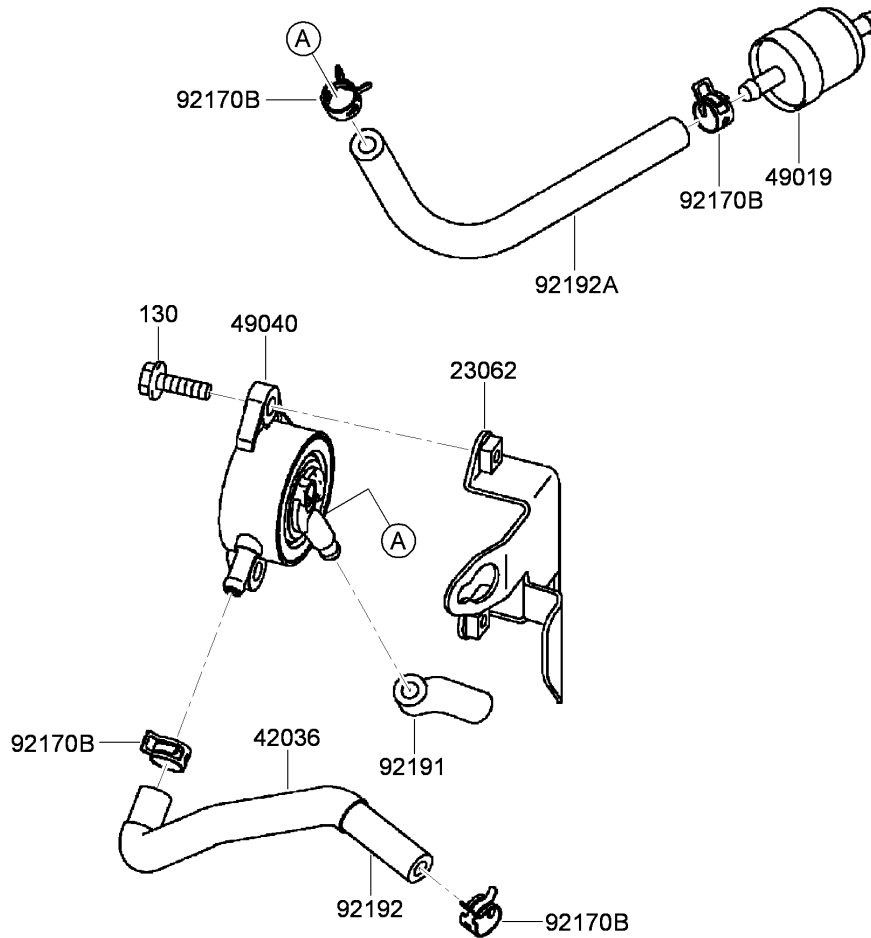

## Fuel Tank and Valve Assembly Kawasaki FH430V-CS25

Ref	Part No.	Qty.	Description				
① 130	130B0620	2	Bolt-Flanged (6X20)				
② 23062	23062-7004-9H	1	Bracket				
③ 42036	42036-7012	1	Sleeve				
④ 49019	49019-7001	1	Filter-Fuel				
⑤ 49040	49040-7001	1	Pump-Fuel				
⑥ 92170B	92170-2088	4	Clamp				
⑦ 92191	92191-7002	1	Tube				
⑧ 92192	92192-7035	1	Tube (6.35X12.7X170)				
⑨ 92192A	92192-7037	1	Tube (6.35X12.7X160)				

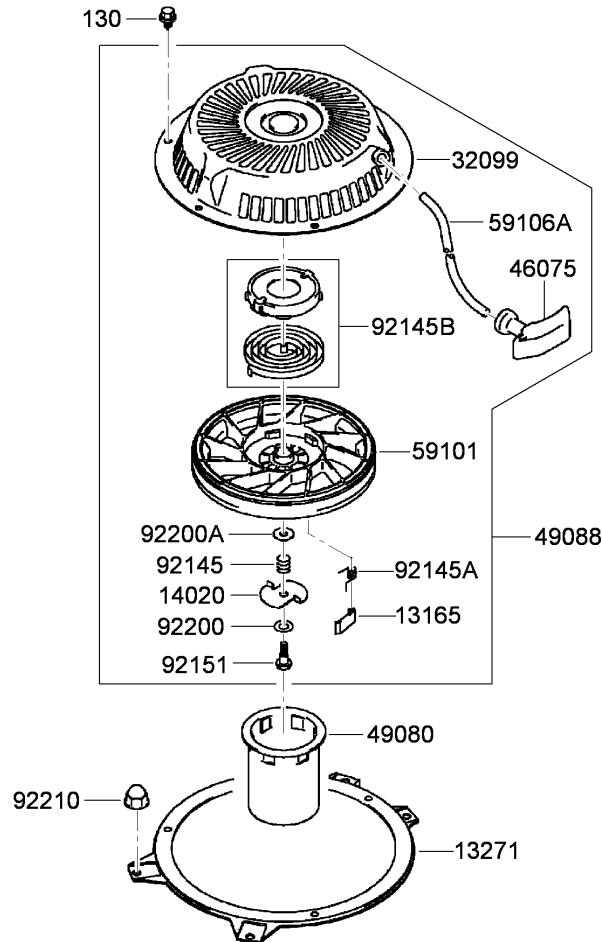

## Starter Assembly Kawasaki FH430V-CS25

Ref	Part No.	Qty.	Description				
① 130	130B0608	3	Bolt-Flanged (6X8)				
① 13165	13165-7001	2	Pawl-Starter, Recoil				
① 13271	13271-7003-9H	1	Plate				
① 14020	14020-7001	1	Retainer				
① 32099	32099-7002	1	Case-Starter, Recoil				
① 46075	46075-7001	1	Grip-Starter, Recoil				
① 49080	49080-7001	1	Pulley-Starting				
① 49088	49088-7013	1	Starter-Recoil				
① 59101	59101-7001	1	Reel-Starter, Recoil				
① 59106A	59106-7005	1	Rope				
① 92145	92145-7006	1	Spring				
① 92145A	92145-7007	2	Spring				
① 92145B	92145-7008	1	Spring				
① 92151	92151-7008	1	Bolt				
① 92200	92200-7004	1	Washer				
① 92200A	92200-7005	1	Washer				
① 92210	92210-0003	4	Nut				

56033

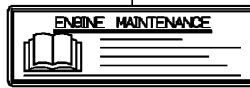

56070



56080



56080A

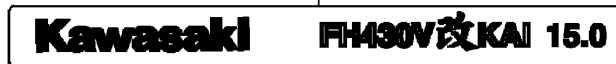

## Label Assembly Kawasaki FH430V-CS25

Ref	Part No.	Qty.	Description				
⑤56033	56033-7001	1	Label-Manual				
⑤56070	56070-7001	1	Label-Warning				
⑤56080	56080-2077	1	Label-Brand				
⑤56080A	56080-7024	1	Label-Brand				

## Attachments and Accessories

### For 30696 - Commercial Walk-Behind Mower, Fixed Deck T-Bar Gear with 40in TURBO FORCE Cutting Unit

Product Name	Model/Part
Blade-Rotary, 14 Inch (Recycling) .....	108-4089-03
Blade-Rotary, 14 Inch (Mid Flow) .....	108-4110-03
Blade-Rotary, 14 Inch (Low Flow) .....	108-4111-03
Blade-Rotary, 14 Inch (Atomic) .....	108-4112-03
40 Inch Bagger Enhancement Kit .....	110-2025
40 Inch Recycler Kit .....	110-2070
Weight Kit .....	110-2085
Plate Kit .....	110-6902
Blade-Recycler, 14 Inch (6-pack) .....	114-4961
Blade-Low Flow, 14inch (6-pack) .....	114-4962
Blade-Mid Flow, 14 Inch (6-pack) .....	114-4963
Blade-High Flow, 14 Inch (6-pack) .....	114-4964
Operator-Controlled Discharge Chute Kit .....	115-4190
Soft Bag (3 Bushel) .....	30104
Sulky .....	30109

# NOTES

