



Count on it.

Operator's Manual

Reelmaster® 5210/5410/5510/5610

Two-Wheel Drive Traction Units

Model No. 03660—Serial No. 290000001 and Up

Model No. 03670—Serial No. 290000001 and Up

Model No. 03680—Serial No. 290000001 and Up

Model No. 03690—Serial No. 290000001 and Up

Model No. 03691—Serial No. 290000001 and Up

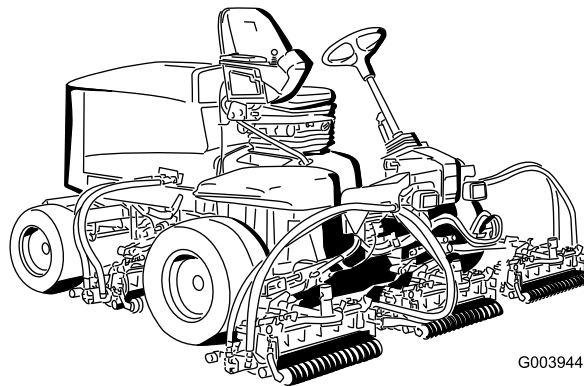

G003944



Warning

CALIFORNIA Proposition 65 Warning

Diesel engine exhaust and some of its constituents are known to the State of California to cause cancer, birth defects, and other reproductive harm.

Important: This engine is not equipped with a spark arrester muffler. It is a violation of California Public Resource Code Section 4442 to use or operate the engine on any forest-covered, brush-covered, or grass-covered land. Other states or federal areas may have similar laws.

Introduction

Read this information carefully to learn how to operate and maintain your product properly and to avoid injury and product damage. You are responsible for operating the product properly and safely.

You may contact Toro directly at www.Toro.com for product and accessory information, help finding a dealer, or to register your product.

Whenever you need service, genuine Toro parts, or additional information, contact an Authorized Service Dealer or Toro Customer Service and have the model and serial numbers of your product ready. The model and serial numbers are on a plate mounted on the left side of the frame under the foot rest. Write the numbers in the space provided.

Model No. _____
Serial No. _____

This manual identifies potential hazards and has safety messages identified by the safety alert symbol (Figure 1), which signals a hazard that may cause serious injury or death if you do not follow the recommended precautions.



Figure 1

1. Safety alert symbol

This manual uses 2 other words to highlight information. **Important** calls attention to special mechanical information and **Note** emphasizes general information worthy of special attention.

Contents

Introduction.....	2
Safety	3
Safe Operating Practices	3
Toro Riding Mower Safety	5
Sound Pressure Level	6
Sound Power Level.....	6
Vibration Level.....	6
Safety and Instructional Decals	7
Setup.....	12
1 Adjusting the Tire Pressure	12
2 Adjusting the Step Height	12
3 Adjusting the Control Arm Position	13
4 Installing the Cutting Units	13
5 Adjusting the Turf Compensation	
Spring	16
6 Installing Rear Weights.....	17
7 Installing the CE Hood Latch.....	21
8 Using the Cutting Unit Kickstand	21
9 Using the Gauge Bar	22
10 Reading the Manual and Viewing the Safety	
Video	22
Product Overview	23
Controls	23
Specifications	26
Attachments/Accessories.....	26
Operation.....	27
Checking the Engine Oil Level.....	27
Checking the Cooling System.....	28
Adding Fuel	28
Checking the Hydraulic Fluid.....	30
Checking the Reel to Bedknife Contact.....	31
Check the Torque of the Wheel Nuts	31
Bleeding the Fuel System	31
Starting and Stopping the Engine	32
Setting the Reel Speed.....	32
Adjusting the Lift Arm Counterbalance.....	33
Adjusting the Lift Arm Turn Around	
Position.....	34
Pushing or Towing the Machine	34
Jacking Points.....	35
Tie Downs	35
Understanding the Diagnostic Light.....	35
Diagnostic Ace Display.....	36
Checking the Interlock Switches	36
Hydraulic Valve Solenoid Functions.....	38

Safety

This machine meets or exceeds CEN standard EN 836:1997, ISO standard 5395:1990, and ANSI B71.4-2004 specifications in effect at time of production, when equipped with rear weight. Refer to the section in this manual on Installing Rear Weight.

Improper use or maintenance by the operator or owner can result in injury. To reduce the potential for injury, comply with these safety instructions and always pay attention to the safety alert symbol, which means Caution, Warning, or Danger—personal safety instruction. Failure to comply with the instruction may result in personal injury or death.

Safe Operating Practices

The following instructions are from the CEN standard EN 836:1997, ISO standard 5395:1990, and ANSI B71.4-2004.

Training

- Read the operator's manual and other training material carefully. Be familiar with the controls, safety signs, and the proper use of the equipment.
- Never allow children or people unfamiliar with these instructions to use or service the mower. Local regulations may restrict the age of the operator.
- Never mow while people, especially children, or pets are nearby.
- Keep in mind that the operator or user is responsible for accidents or hazards occurring to other people or their property.
- Do not carry passengers.
- All drivers and mechanics should seek and obtain professional and practical instruction. The owner is responsible for training the users. Such instruction should emphasize:
 - the need for care and concentration when working with ride-on machines;
 - control of a ride-on machine sliding on a slope will not be regained by the application of the brake. The main reasons for loss of control are:
 - ◇ insufficient wheel grip;
 - ◇ being driven too fast;
 - ◇ inadequate braking;
 - ◇ the type of machine is unsuitable for its task;

Operating Tips	38
Maintenance	39
Recommended Maintenance Schedule(s)	39
Daily Maintenance Checklist	40
Service Interval Chart	41
Lubrication	41
Greasing the Bearings and Bushings	41
Engine Maintenance	43
Servicing the Air Cleaner	43
Servicing the Engine Oil and Filter	43
Adjusting the Throttle	44
Fuel System Maintenance	45
Draining the Fuel Tank	45
Checking the Fuel Lines and Connections	45
Servicing the Water Separator	45
Fuel Pick-up Tube Screen	45
Bleeding Air from the Fuel Injectors	45
Electrical System Maintenance	46
Servicing the Battery	46
Fuses	47
Drive System Maintenance	47
Adjusting the Traction Drive for Neutral	47
Adjusting the Rear Wheel Toe-in	48
Cooling System Maintenance	49
Removing Debris from the Cooling System	49
Brake Maintenance	50
Adjusting the Service Brakes	50
Adjusting the Parking Brake	50
Belt Maintenance	51
Tensioning the Alternator Belt	51
Hydraulic System Maintenance	51
Changing the Hydraulic Fluid	51
Replacing the Hydraulic Filters	52
Checking the Hydraulic Lines and Hoses	52
Hydraulic System Test Ports	53
Cutting Unit System Maintenance	54
Backlapping the Cutting Units	54
Storage	55
Preparing the Traction Unit	55
Preparing the Engine	55
Schematics	56

- ◇ lack of awareness of the effect of ground conditions, especially slopes;
- ◇ incorrect hitching and load distribution.
- The owner/user can prevent and is responsible for accidents or injuries occurring to himself or herself, other people, or property.

Preparation

- While mowing, always wear substantial footwear, long trousers, hard hat, safety glasses, and ear protection. Long hair, loose clothing, or jewelry may get tangled in moving parts. Do not operate the equipment when barefoot or wearing open sandals.
- Thoroughly inspect the area where the equipment is to be used and remove all objects which may be thrown by the machine.
- **Warning**—Fuel is highly flammable. Take the following precautions:
 - Store fuel in containers specifically designed for this purpose.
 - Refuel outdoors only and do not smoke while refuelling.
 - Add fuel before starting the engine. Never remove the cap of the fuel tank or add fuel while the engine is running or when the engine is hot.
 - If fuel is spilled, do not attempt to start the engine but move the machine away from the area of spillage and avoid creating any source of ignition until fuel vapors have dissipated.
 - Replace all fuel tanks and container caps securely.
- Replace faulty silencers/mufflers.
- Evaluate the terrain to determine what accessories and attachments are needed to properly and safely perform the job. Only use accessories and attachments approved by the manufacturer.
- Check that the operator's presence controls, safety switches and shields are attached and functioning properly. Do not operate unless they are functioning properly.

Operation

- Do not operate the engine in a confined space where dangerous carbon monoxide fumes can collect.
- Mow only in daylight or in good artificial light.
- Before attempting to start the engine, disengage all blade attachment clutches, shift into neutral, and engage the parking brake.
- Remember there is no such thing as a safe slope. Travel on grass slopes requires particular care. To guard against overturning:
 - do not stop or start suddenly when going up or downhill;
 - machine speeds should be kept low on slopes and during tight turns;
 - stay alert for humps and hollows and other hidden hazards;
 - Do not turn sharply. Use care when reversing.
 - Use counterweight(s) or wheel weights when suggested in the operator's manual.
- Stay alert for holes in the terrain and other hidden hazards.
- Watch out for traffic when crossing or near roadways.
- Stop the blades rotating before crossing surfaces other than grass.
- When using any attachments, never direct discharge of material toward bystanders nor allow anyone near the machine while in operation.
- Never operate the machine with damaged guards, shields, or without safety protective devices in place. Be sure all interlocks are attached, adjusted properly, and functioning properly.
- Do not change the engine governor settings or over-speed the engine. Operating the engine at excessive speed may increase the hazard of personal injury.
- Before leaving the operator's position:
 - stop on level ground;
 - disengage the power take-off and lower the attachments;
 - change into neutral and set the parking brake;
 - stop the engine and remove the key.
- Disengage drive to attachments when transporting or not in use.
- Stop the engine and disengage drive to attachment:
 - before refuelling;
 - before removing the grass catcher/catchers;
 - before making height adjustment unless adjustment can be made from the operator's position.
 - before clearing blockages;
 - before checking, cleaning or working on the mower;
 - after striking a foreign object or if an abnormal vibration occurs. Inspect the mower for damage and make repairs before restarting and operating the equipment.

- Reduce the throttle setting during engine run-out and, if the engine is provided with a shut-off valve, turn the fuel off at the conclusion of mowing.
- Keep hands and feet away from the cutting units.
- Look behind and down before backing up to be sure of a clear path.
- Slow down and use caution when making turns and crossing roads and sidewalks. Stop cylinders/reels if not mowing.
- Do not operate the mower under the influence of alcohol or drugs.
- Use care when loading or unloading the machine into a trailer or truck.
- Use care when approaching blind corners, shrubs, trees, or other objects that may obscure vision.
- Carefully release pressure from components with stored energy.
- Disconnect battery before making any repairs. Disconnect the negative terminal first and the positive last. Reconnect positive first and negative last.
- Use care when checking the cylinders/reels. Wear gloves and use caution when servicing them.
- Keep hands and feet away from moving parts. If possible, do not make adjustments with the engine running.
- Charge batteries in an open well ventilated area, away from spark and flames. Unplug charger before connecting or disconnecting from battery. Wear protective clothing and use insulated tools.

Maintenance and Storage

- Keep all nuts, bolts and screws tight to be sure the equipment is in safe working condition.
- Never store the equipment with fuel in the tank inside a building where fumes may reach an open flame or spark.
- Allow the engine to cool before storing in any enclosure.
- To reduce the fire hazard, keep the engine, silencer/muffler, battery compartment and fuel storage area free of grass, leaves, or excessive grease.
- Check the grass catcher frequently for wear or deterioration.
- Keep all parts in good working condition and all hardware and hydraulic fittings tightened. Replace all worn or damaged parts and decals.
- If the fuel tank has to be drained, do this outdoors.
- Be careful during adjustment of the machine to prevent entrapment of the fingers between moving blades and fixed parts of the machine.
- On multi-cylinder/multi-reel machines, take care as rotating one cylinder/reel can cause other cylinders/reels to rotate.
- Disengage drives, lower the cutting units, set parking brake, stop engine and remove key from ignition. Wait for all movement to stop before adjusting, cleaning or repairing.
- Clean grass and debris from cutting units, drives, silencers/mufflers, and engine to help prevent fires. Clean up oil or fuel spillage.
- Use jack stands to support components when required.

Toro Riding Mower Safety

The following list contains safety information specific to Toro products or other safety information that you must know that is not included in the CEN, ISO, or ANSI standard.

This product is capable of amputating hands and feet and throwing objects. Always follow all safety instructions to avoid serious injury or death.

Use of this product for purposes other than its intended use could prove dangerous to user and bystanders.



Engine exhaust contains carbon monoxide, which is an odorless, deadly poison that can kill you.

Do not run engine indoors or in an enclosed area.

- Know how to stop the engine quickly.
- Do not operate the machine while wearing tennis shoes or sneakers.
- Wearing safety shoes and long pants is advisable and required by some local ordinances and insurance regulations.
- Handle fuel carefully. Wipe up any spills.
- Check the safety interlock switches daily for proper operation. If a switch should fail, replace the switch before operating the machine.
- Before starting the engine, sit on the seat.
- Using the machine demands attention. To prevent loss of control:

- Do not drive close to sand traps, ditches, creeks, or other hazards.
- Reduce speed when making sharp turns. Avoid sudden stops and starts.
- When near or crossing roads, always yield the right-of-way.
- Apply the service brakes when going downhill to keep forward speed slow and to maintain control of the machine.
- Raise the cutting units when driving from one work area to another.
- Do not touch the engine, silencer/muffler, or exhaust pipe while the engine is running or soon after it has stopped because these areas could be hot enough to cause burns.
- If the engine stalls or loses headway and cannot make it to the top of a slope, do not turn the machine around. Always back slowly, straight down the slope.
- When a person or pet appears unexpectedly in or near the mowing area, stop mowing. Careless operation, combined with terrain angles, ricochets, or improperly positioned guards can lead to thrown object injuries. Do not resume mowing until the area is cleared.

Maintenance and Storage

- Make sure all hydraulic line connectors are tight and all hydraulic hoses and lines are in good condition before applying pressure to the system.
- Keep your body and hands away from pin hole leaks or nozzles that eject hydraulic fluid under high pressure. Use paper or cardboard, not your hands, to search for leaks. Hydraulic fluid escaping under pressure can have sufficient force to penetrate the skin and cause serious injury. Seek immediate medical attention if fluid is injected into skin.
- Before disconnecting or performing any work on the hydraulic system, all pressure in the system must be relieved by stopping the engine and lowering the cutting units and attachments to the ground.
- Check all fuel lines for tightness and wear on a regular basis. Tighten or repair them as needed.
- If the engine must be running to perform a maintenance adjustment, keep hands, feet, clothing, and any parts of the body away from the cutting units, attachments, and any moving parts. Keep everyone away.
- To ensure safety and accuracy, have an Authorized Toro Distributor check the maximum engine speed

with a tachometer. Maximum governed engine speed should be 3200 RPM.

- If major repairs are ever needed or if assistance is desired, contact an Authorized Toro Distributor.
- Use only Toro-approved attachments and replacement parts. The warranty may be voided if used with unapproved attachments.

Sound Pressure Level

These units have an equivalent continuous A-weighted sound pressure at the operator ear of: 85 dB(A), based on measurements of identical machines per ISO 11201.

Sound Power Level

These units have a guaranteed sound power level of: 105 dBA/1 pW, based on measurements of identical machines per ISO11094.

Vibration Level

This unit does not exceed a vibration level of 2.5 m/s² at the hands based on measurements of identical machines per EN 1033 and EN836.

This unit does not exceed a vibration level of 0.5 m/s² at the posterior based on measurements of identical machines per EN 1032 and EN836.

Safety and Instructional Decals



Safety decals and instructions are easily visible to the operator and are located near any area of potential danger. Replace any decal that is damaged or lost.



108-5278

1. Read the *Operator's Manual*.

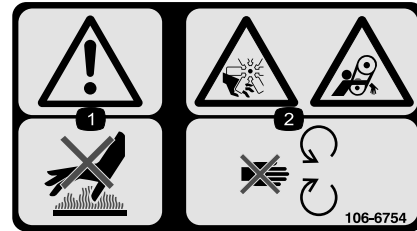

106-6754

1. Warning—do not touch the hot surface.
2. Cutting/dismemberment hazard, fan and entanglement hazard, belt—stay away from moving parts.

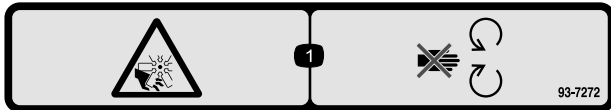

93-7272

1. Cutting/dismemberment hazard; fan—stay away from moving parts.

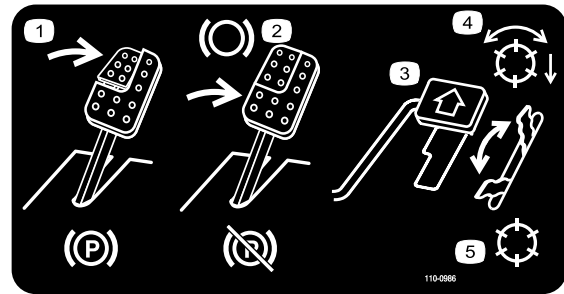

110-0986

1. Press the brake pedal and parking brake pedal to set the parking brake.
2. Press the brake pedal to apply the brake.
3. Press the traction pedal to move the machine forward.
4. Reel enabled mode
5. Transport mode

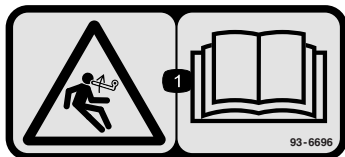

93-6696

1. Stored energy hazard—read the *Operator's Manual*.

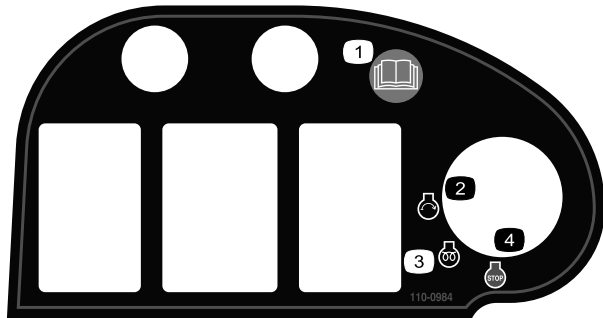

110-0984

1. Read the *Operator's Manual*.
2. Engine—Start
3. Engine—Preheat
4. Engine—Stop

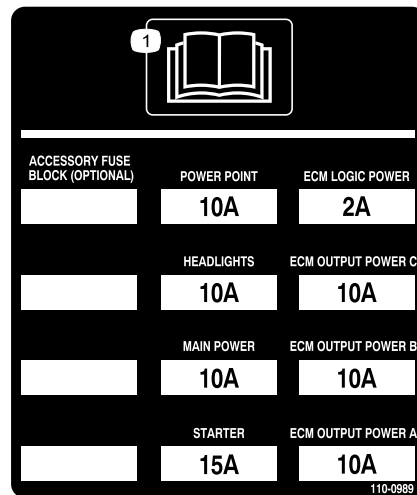

110-0989

1. Read the *Operator's Manual*.

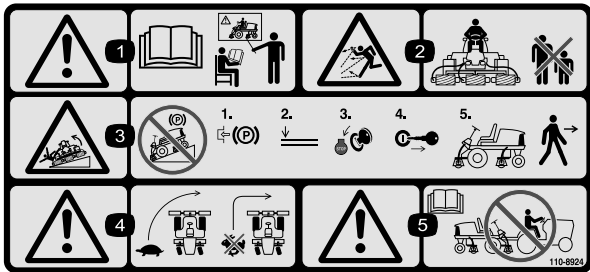

110-8924

1. Warning—read the *Operator's Manual* and receive training.
2. Thrown object hazard—keep bystanders a safe distance from the machine.
3. Warning—do not park the machine on slopes; engage the parking brake, lower the cutting units, stop the engine and remove the ignition key before leaving the machine.
4. Tipping hazard—slow machine before turning, do not turn at high speeds; lower the cutting unit when driving down slopes.
5. Warning—read the *Operator's Manual*, do not tow the machine.

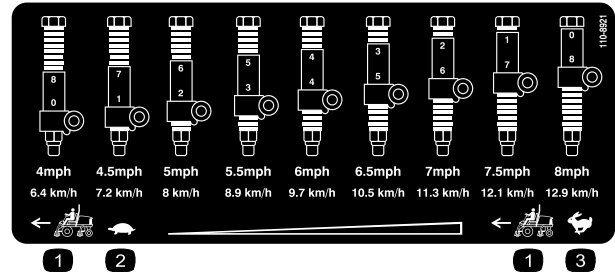

110-8921

1. Traction unit speed
2. Slow
3. Fast

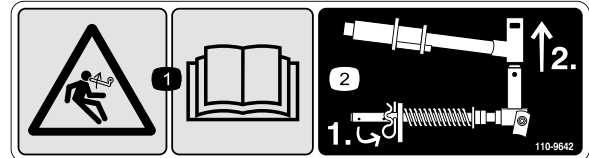

110-9642

1. Stored energy hazard—read the *Operator's Manual*.
2. Move the cotter pin to the hole closest to the rod bracket and then remove the lift arm and pivot yoke.

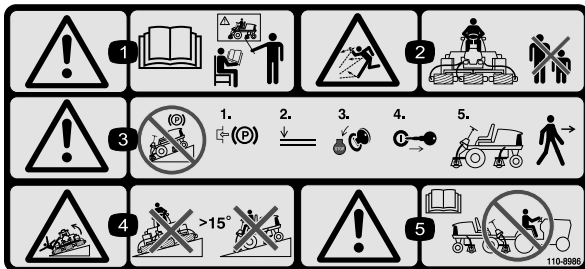

110-8986

(Affix over part no. 110-8924 for CE*)

* This safety decal includes a slope warning required on the machine for compliance to the European Lawn Mower Safety Standard EN836:1997. The conservative maximum slope angles indicated for operation of this machine are prescribed by and required by this standard.

1. Warning—read the *Operator's Manual* and receive training.
2. Thrown object hazard—keep bystanders a safe distance from the machine.
3. Warning—do not park the machine on slopes; engage the parking brake, lower the cutting units, stop the engine and remove the ignition key before leaving the machine.
4. Tipping hazard—do not operate on slopes greater than 15°.
5. Warning—read the *Operator's Manual*, do not tow the machine.



106-6755

1. Engine coolant under pressure.
2. Explosion hazard—read the *Operator's Manual*.
3. Warning—do not touch the hot surface.
4. Warning—read the *Operator's Manual*.

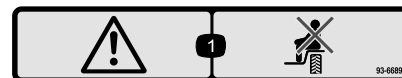

93-6689

1. Warning—do not carry passengers.

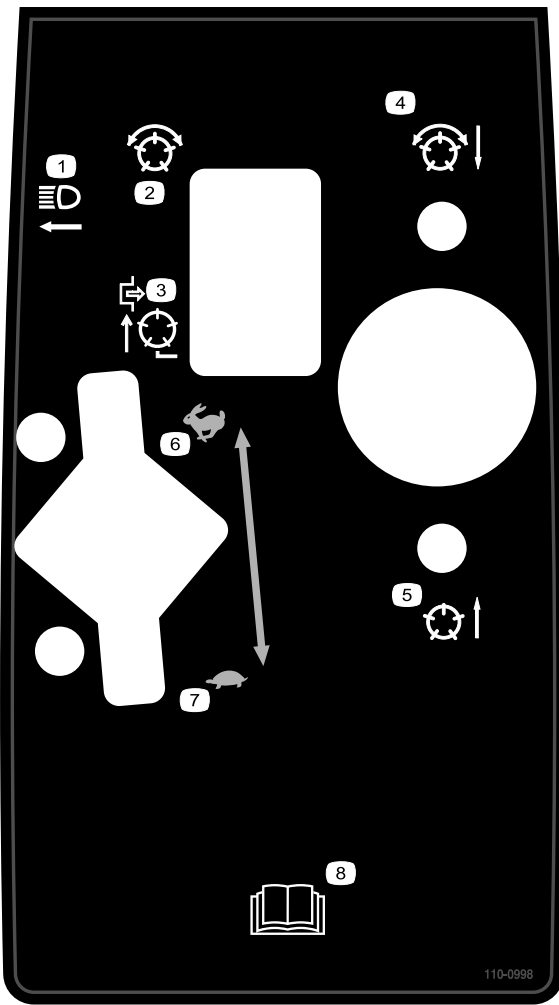

110-0998

- | | |
|--|--|
| 1. Headlights | 5. Reels raised and off |
| 2. Reels—enabled | 6. Throttle—fast |
| 3. Reels disabled—lift only | 7. Throttle—slow |
| 4. Reels lowered and on when enabled—forward and backlap | 8. Read the <i>Operator's Manual</i> . |



Battery Symbols

Some or all of these symbols are on your battery

- | | |
|--|--|
| 1. Explosion hazard | 6. Keep bystanders a safe distance from the battery. |
| 2. No fire, open flame, or smoking. | 7. Wear eye protection; explosive gases can cause blindness and other injuries |
| 3. Caustic liquid/chemical burn hazard | 8. Battery acid can cause blindness or severe burns. |
| 4. Wear eye protection | 9. Flush eyes immediately with water and get medical help fast. |
| 5. Read the <i>Operator's Manual</i> . | 10. Contains lead; do not discard. |

REELMASTER 5210 / 5410 / 5510 / 5610 QUICK REFERENCE AID



CHECK/SERVICE (daily)

1. OIL LEVEL, ENGINE
2. OIL LEVEL, HYDRAULIC TANK
3. COOLANT LEVEL, RADIATOR
4. FUEL /WATER SEPARATOR
5. PRECLEANER -- AIR CLEANER

6. RADIATOR SCREEN
 7. BRAKE FUNCTION
 8. TIRE PRESSURE
 9. BATTERY
 10. BELTS (FAN, ALT.)
- GREASING – SEE OPERATOR'S MANUAL

FLUID SPECIFICATIONS/CHANGE INTERVALS

SEE OPERATOR'S MANUAL FOR INITIAL CHANGES.	FLUID TYPE	CAPACITY	CHANGE INTERVAL		FILTER PART NO.
			FLUID	FILTER	
A. ENGINE OIL	SAE 15W-40CI-4	3.5 QTS. (5210) 5.5 QTS. (5410) (5510) (5610)	150 HRS.	150 HRS.	104-5167
B. HYD. CIRCUIT OIL	ISO VG 46/68	9 GALS.*	800 HRS.	SEE INDICATOR 800 HRS.	84-2621 86-3910
C. AIR CLEANER				SEE INDICATOR	100-3810 (5210) 5410 (5510) 100-3812 (5610)
D. WATER SEPARATOR				400 HRS.	110-9049
E. FUEL TANK	NO. 2-DIESEL	14 GALS.	DRAIN AND FLUSH, 2 YRS.		
F. COOLANT	50/50 ETHYLENE GLYCOL/WATER	5.5 QTS. (5210) 7.0 QTS. (5410) (5510) 10.0 QTS. (5610)	DRAIN AND FLUSH, 2 YRS.		

* INCLUDING FILTER

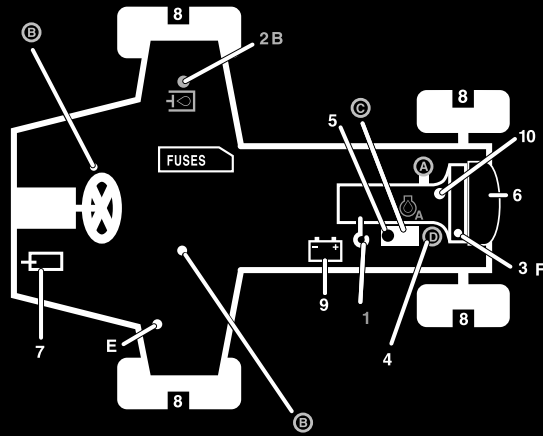

114-0429

114-0429

1. Read the *Operator's Manual*.

Setup

Loose Parts

Use the chart below to verify that all parts have been shipped.

Procedure	Description	Qty.	Use
1	No parts required	–	Adjust the tire pressure.
2	No parts required	–	Adjust the step height.
3	No parts required	–	Adjust the control arm position.
4	Front hose guide-R.H. Front hose guide-L.H.	1 1	Install the cutting units
5	No parts required	–	Adjust the turf compensation spring.
6	Rear weights (size varies with configuration).	Varies	Install rear weights (order from your Toro Distributor).
7	Hood latch assembly Washer	1 1	Install the CE Hood Latch
8	Cutting unit kickstand	1	Install the Cutting Unit Kickstand.
9	Gauge bar	1	Use the gauge bar to adjust the cutting unit.
10	Operator's Manual Engine Operator's Manual Parts Catalog CE certificate Operator Training Material	1 1 1 1 1	Read the Operator's Manual and watch the video before operating the machine.

Note: Determine the left and right sides of the machine from the normal operating position.

1

Adjusting the Tire Pressure

No Parts Required

Procedure

The tires are over-inflated for shipping. Therefore, release some of the air to reduce the pressure. Correct air pressure in the front and rear tires is 12 to 15 psi (83 to 103 kPa).

Important: Maintain even pressure in all tires to ensure uniform contact with the turf.

2

Adjusting the Step Height

No Parts Required

Procedure

The height of the steps can be adjusted for the operators comfort.

1. Remove the 2 bolts and nuts securing the step brackets to the traction unit frame (Figure 2)

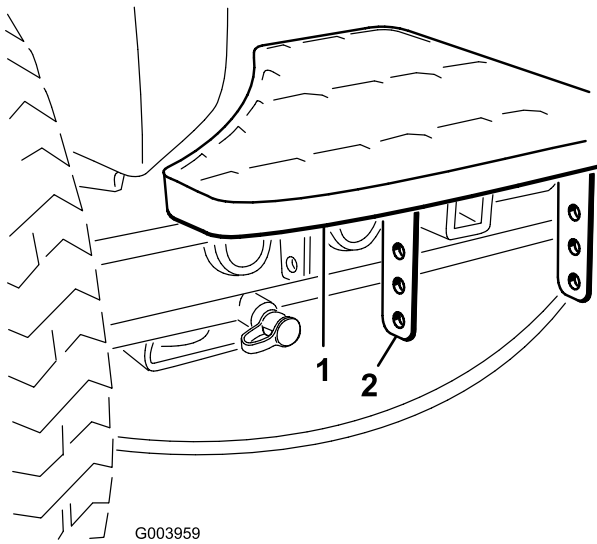

Figure 2

1. Step
2. Step brackets

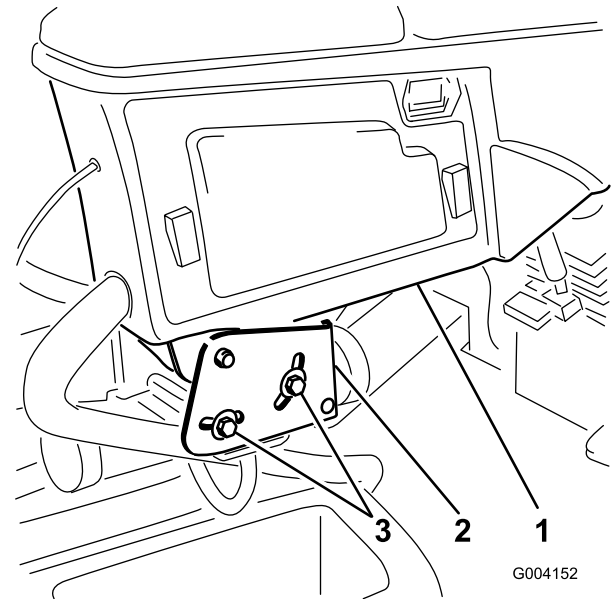

Figure 3

1. Control arm
 2. Retaining brackets
 3. Bolts (2)
2. Rotate the control arm to the desired position and tighten the 2 bolts.

2. Raise or lower the step to the desired height and re-secure the brackets to the frame with the 2 bolts and nuts.
3. Repeat the procedure on the other step.

3

Adjusting the Control Arm Position

No Parts Required

Procedure

The control arm position can be adjusted for the operators comfort.

1. Loosen the 2 bolts securing the control arm to the retaining bracket (Figure 3).

4

Installing the Cutting Units

Parts needed for this procedure:

1	Front hose guide-R.H.
1	Front hose guide-L.H.

Procedure

1. Remove the reel motors from the shipping brackets.
2. Remove the shipping brackets and discard.
3. Remove the cutting units from the cartons. Assemble and adjust as described in the cutting unit *Operator's Manual*.
4. Make sure the counter weight (Figure 4) is installed to the proper end of the cutting unit as described in the cutting unit *Operator's Manual*.

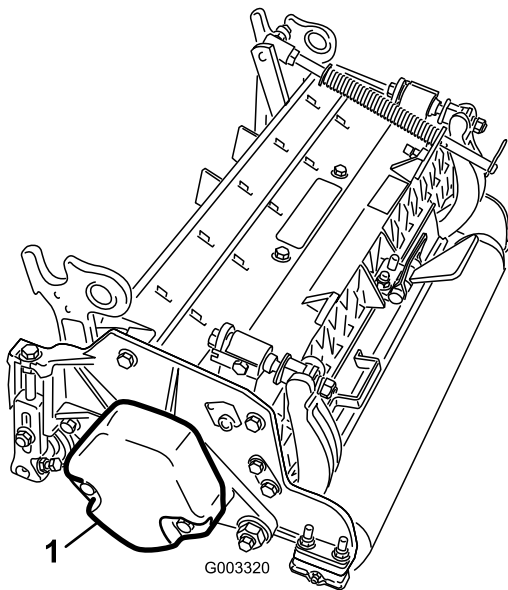

Figure 4

1. Counter weight

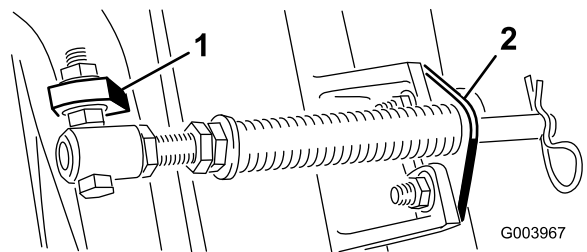

Figure 6

1. Opposite carrier frame tab
2. Rod bracket

D. Mount the rod bracket to the cutting unit tabs with the carriage bolts and nuts (Figure 6). Also, on the #4 cutting unit, mount the left hand hose guide to the front of the cutting unit tabs when reinstalling the rod bracket (Figure 7).

Note: On the #5 cutting unit, use the rod bracket mounting nuts to install the right hand hose guide to the front of the cutting unit tabs.

5. All the cutting units are shipped with the turf compensation spring mounted to the right side of the cutting unit. The turf compensation spring must be mounted to the same side of the cutting unit as the reel drive motor. Reposition the turf compensation as follows:
 - A. Remove the 2 carriage bolts and nuts securing the rod bracket to the cutting unit tabs (Figure 5).

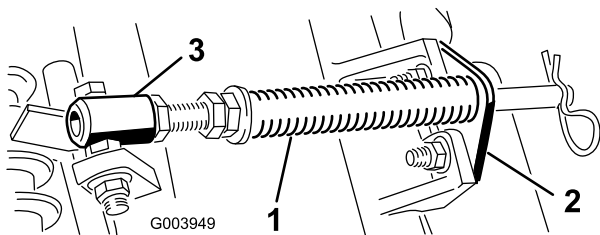

Figure 5

1. Turf compensation spring
2. Rod bracket
3. Spring tube

- B. Remove the flange nut securing the spring tube capscrew to the carrier frame tab (Figure 5) Remove the assembly.
 - C. Mount the spring tube capscrew to the opposite tab on the carrier frame and secure with the flange nut. The capscrew head is to be positioned to the outer side of the tab as shown in Figure 6.

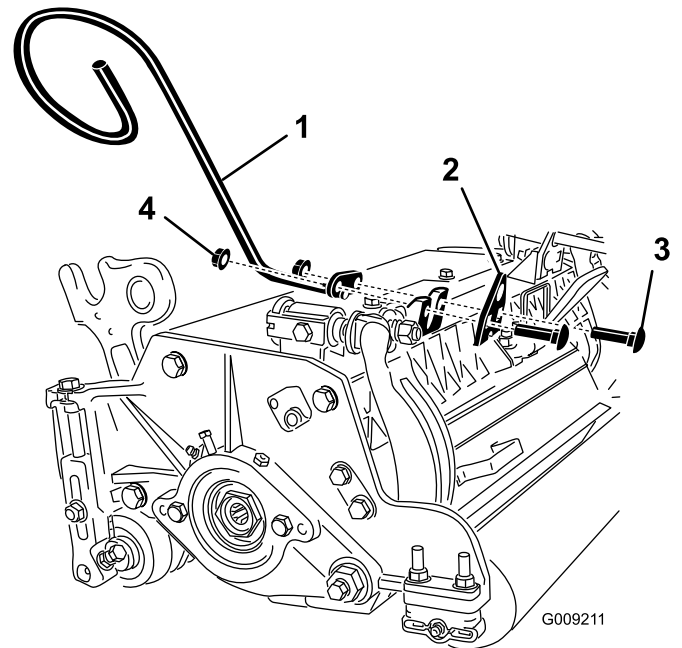
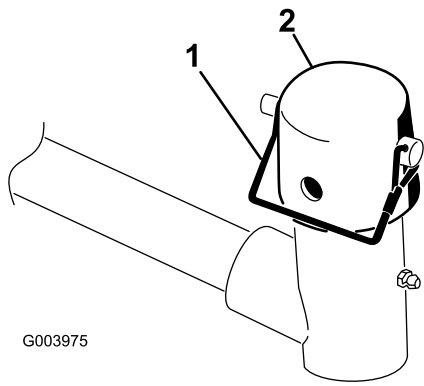

Figure 7

1. Hose guide (Left hand shown)
2. Rod bracket
3. Carriage bolts
4. Nuts

Note: When installing or removing the cutting units, make sure the hairpin cotter is installed in the spring rod hole next to the rod bracket. Otherwise, the hairpin cotter must be installed in the hole in the end of the rod.

6. Lower all the lift arms completely.
7. Remove the snapper pin and the cap from the lift arm pivot yoke (Figure 8).



G003975

Figure 8

- 1. Snapper pin
- 2. Cap

8. For the front cutting units, slide a cutting unit under the lift arm while inserting the carrier frame shaft up into the lift arm pivot yoke (Figure 9).

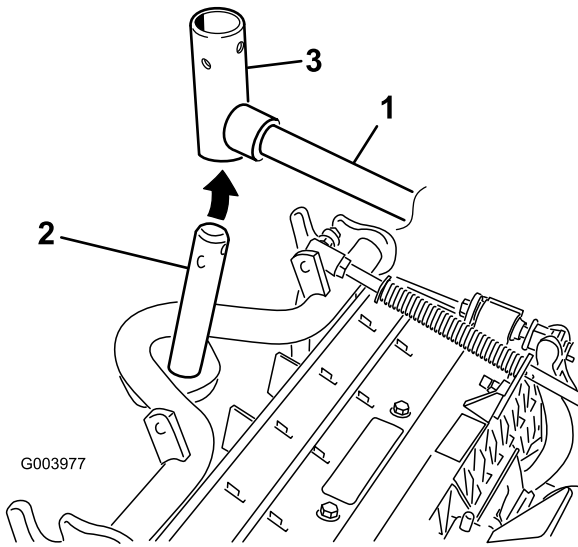

G003977

Figure 9

- 1. Lift arm
- 2. Carrier frame shaft
- 3. Lift arm pivot yoke

9. Use the following procedure on the rear cutting units when the height of cut is above 3/4 inch.

A. Remove the lynch pin and washer securing the lift arm pivot shaft to the lift arm and slide the lift arm pivot shaft out of the lift arm (Figure 10).

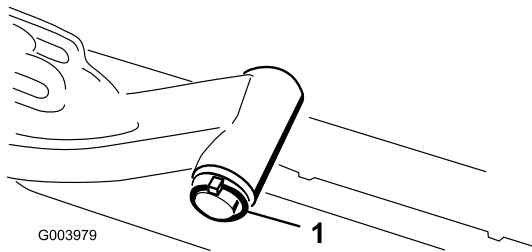

G003979

Figure 10

- 1. Lift arm pivot shaft lynch pin and washer

B. Insert the lift arm yoke onto the carrier frame shaft (Figure 9).

C. Insert the lift arm shaft into the lift arm and secure it with the washer and lynch pin (Figure 10).

10. Insert the cap over the carrier frame shaft and lift arm yoke.

11. Secure the cap and the carrier frame shaft to the lift arm yoke with the snapper pin. Use the slot if a steering cutting unit is desired or use the hole if the cutting unit is to be locked in position (Figure 8).

12. Secure the lift arm chain to the chain bracket with the snapper pin (Figure 11). Use the number of chain links described in the cutting unit *Operator's Manual*.

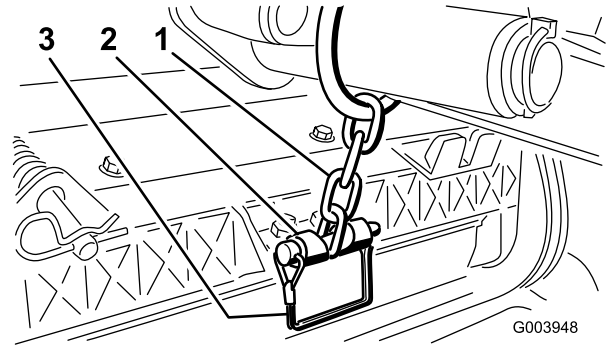

G003948

Figure 11

- 1. Lift arm chain
- 2. Chain bracket

13. Coat the spline shaft of the reel motor with clean grease.

14. Oil the reel motor O-ring and install it onto the motor flange.

15. Install the motor by rotating it clockwise so that the motor flanges clear the capscrews (Figure 12). Rotate the motor counterclockwise until the flanges encircle the capscrews then tighten the capscrews.

Important: Make sure the reel motor hoses are not twisted, kinked or in the risk of being pinched.

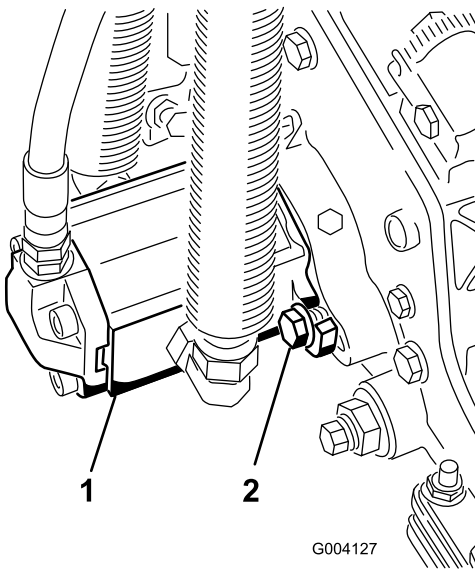

Figure 12

1. Reel drive motor
2. Mounting capscrews

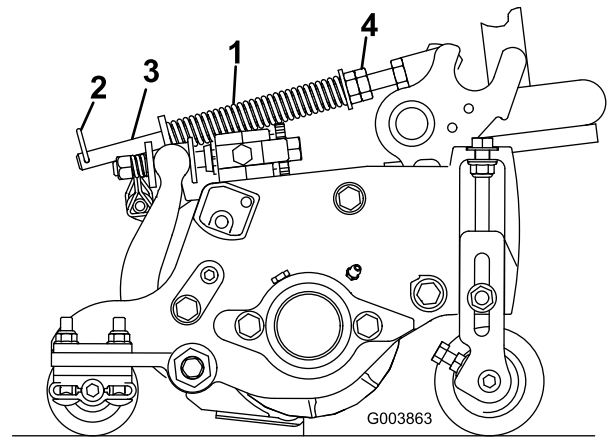

Figure 13

1. Turf compensation spring
 2. Hair pin cotter
 3. Spring rod
 4. Hex nuts
2. Tighten the hex nuts on the front end of the spring rod until the compressed length of the spring is 5 inches (12.7 cm) on Reelmaster 5210 & 5410, 5 inch cutting units or 6.25 inches (15.9 cm) on Reelmaster 5510 & 5610, 7 inch cutting units (Figure 13).

Note: When operating on rough terrain decrease the spring length by 1/2 inch. Ground following will be slightly decreased.

5

Adjusting the Turf Compensation Spring

No Parts Required

Procedure

The turf compensation spring (Figure 13) transfers weight from the front to the rear roller. (This helps to reduce a wave pattern in the turf, also known as marcelling or bobbing.)

Important: Make spring adjustments with the cutting unit mounted to the traction unit, pointing straight ahead and lowered to the shop floor.

1. Make sure the hairpin cotter is installed in the rear hole in the spring rod (Figure 13).

6

Installing Rear Weights

Parts needed for this procedure:

Varies	Rear weights (size varies with configuration).
--------	--

Procedure

The Reelmaster 5210/5410/5510 and 5610 Traction Units comply with CEN standard EN 836:1997, ISO standard 5395:1990, and ANSI B71.4-2004 Standards when equipped with rear weights and/or 90 lb of calcium chloride ballast is added to rear wheels. Use the following charts to determine the combinations of weights required for your configuration. Order parts from your local Authorized Toro Distributor.

Weight P/N 110-8985-03						
Tractor	2* or 4 Wheel Drive	Groomers, roller brushes, and/or baskets	Number of weights to meet ANSI (US) standards	Number of weights to meet CE (European) standards	Fasteners (2 each required) for weights	Weight Location
RM5210	2*	No	0	0	N/A	N/A
		Yes	90 lb calcium chloride**	7	3231-11 Carriage Bolt, 104-8301 Nut	Under bumper
	4	No	0	0	N/A	N/A
		Yes	2	0	3231-6 Carriage Bolt, 104-8301 Nut	Under bumper
RM5410	2*	No	0	0	N/A	N/A
		Yes	90 lb calcium chloride**	9	3231-34 Carriage Bolt, 104-8301 Nut	Under bumper
	4	No	0	0	N/A	N/A
		Yes	2	0	3231-6 Carriage Bolt, 104-8301 Nut	Under bumper
RM5510	2*	No	4	0	3231-7 Carriage Bolt, 104-8301 Nut	1 on top of bumper and 3 under bumper
		Yes	90 lb calcium chloride**	90 lb calcium chloride**	N/A	N/A
	4	No	0	0	N/A	N/A
		Yes	4	4	3231-7 Carriage Bolt, 104-8301 Nut	1 on top of bumper and 3 under bumper
RM5610	2*	No	0	0	N/A	N/A
		Yes	9	4	3231-34 Carriage Bolt, 104-8301 Nut	Under bumper
	4	No	0	0	N/A	N/A
		Yes	0	0	N/A	N/A

* Includes 2WD units with the ROPS option.

** Install tubes inside the rear tires before adding calcium chloride.

Use the following chart to determine the rear weight requirements when a 4 Post ROPS Conversion Kit is added.

Weight P/N 110-8985-03						
Tractor	2* or 4 Wheel Drive	Groomers, roller brushes, and/or baskets	Number of weights to meet ANSI (US) standards	Number of weights to meet CE (European) standards	Fasteners (2 each required) for weights	Weight Location
RM5210	2*	No	9	9	3231-34 Carriage Bolt, 104-8301 Nut	2 on top of bumper and 7 under bumper
		Yes	90 lb calcium chloride** plus 5 weights	90 lb calcium chloride**	3231-11 Carriage Bolt, 104-8301 Nut	Under bumper
	4	No	90 lb calcium chloride**	90 lb calcium chloride**	N/A	N/A
		Yes	90 lb calcium chloride**	90 lb calcium chloride**	N/A	N/A
RM5410	2*	No	9	9	3231-34 Carriage Bolt, 104-8301 Nut	2 on top of bumper and 7 under bumper
		Yes	90 lb calcium chloride** plus 5 weights	9	3231-34 Carriage Bolt, 104-8301 Nut	2 on top of bumper and the remaining under bumper
	4	No	4	4	3231-7 Carriage Bolt, 104-8301 Nut	1 on top of bumper and 3 under bumper
		Yes	90 lb calcium chloride**	90 lb calcium chloride**	N/A	N/A
RM5510	2*	No	90 lb calcium chloride**	9	3231-34 Carriage Bolt, 104-8301 Nut	2 on top of bumper and 7 under bumper
		Yes	90 lb calcium chloride** plus 9 weights	90 lb calcium chloride** plus 5 weights	3231-34 Carriage Bolt, 104-8301 Nut	2 on top of bumper and the remaining under bumper
	4	No	4	4	3231-7 Carriage Bolt, 104-8301 Nut	1 on top of bumper and 3 under bumper
		Yes	90 lb calcium chloride**	90 lb calcium chloride**	N/A	N/A
RM5610	2*	No	4	4	3231-7 Carriage Bolt, 104-8301 Nut	Under bumper
		Yes	90 lb calcium chloride** plus 2 weights	9	3231-34 Carriage Bolt, 104-8301 Nut	2 on top of bumper and the remaining under bumper
	4	No	0	0	N/A	N/A
		Yes	4	4	3231-7 Carriage Bolt, 104-8301 Nut	1 on top of bumper and 3 under bumper
* Includes 2WD units with the ROPS option.						
** Install tubes inside the rear tires before adding calcium chloride.						

Use the following chart to determine the rear weight requirements when the traction unit is also equipped with a Sunshade Canopy on a 2 Post ROPS.

Weight P/N 110-8985-03						
Tractor	2* or 4 Wheel Drive	Groomers, roller brushes, and/or baskets	Number of weights to meet ANSI (US) standards	Number of weights to meet CE (European) standards	Fasteners (2 each required) for weights	Weight Location
RM5210	2*	No	2	0	3231-6 Carriage Bolt, 104-8301 Nut	Under bumper
		Yes	90 lb calcium chloride**	9	3231-34 Carriage Bolt, 104-8301 Nut	Under bumper
	4	No	0	0	N/A	N/A
		Yes	4	2	3231-7 Carriage Bolt, 104-8301 Nut	1 on top of bumper and the remaining under bumper
RM5410	2*	No	2	2	3231-6 Carriage Bolt, 104-8301 Nut	Under bumper
		Yes	90 lb calcium chloride**	9	3231-34 Carriage Bolt, 104-8301 Nut	2 on top of bumper and 7 under bumper
	4	No	0	0	N/A	N/A
		Yes	4	2	3231-7 Carriage Bolt, 104-8301 Nut	Under bumper
RM5510	2*	No	6	2	3231-34 Carriage Bolt, 104-8301 Nut	Under bumper
		Yes	90 lb calcium chloride**	90 lb calcium chloride**	N/A	N/A
	4	No	0	0	N/A	N/A
		Yes	6	6	3231-34 Carriage Bolt, 104-8301 Nut	3 on top of bumper and 3 under bumper
RM5610	2*	No	0	0	N/A	N/A
		Yes	90 lb calcium chloride**	6	3231-34 Carriage Bolt, 104-8301 Nut	2 on top of bumper and 4 under bumper
	4	No	0	0	N/A	N/A
		Yes	0	0	N/A	N/A
* Includes 2WD units with the ROPS option.						
** Install tubes inside the rear tires before adding calcium chloride.						

Important: Always install tubes inside the rear tires before calcium chloride is installed. If a puncture occurs in a tire with calcium chloride, remove the machine from the turf area as quickly as possible. To prevent possible damage to the turf, immediately soak the affected area with water.

On two wheel drive models, mount the appropriate amount of weight (see weight charts) to the top or bottom of the rear bumper as shown in Figure 14.

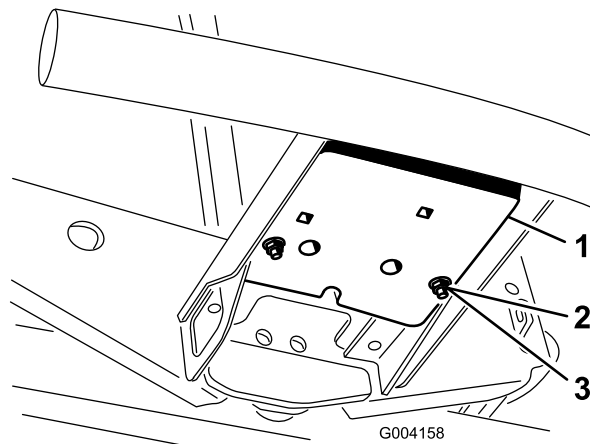

Figure 14

- 1. Weight
- 2. Carriage bolt

- 3. Nut

On four wheel drive models, use the following procedure to mount the appropriate amount of weight (see weight charts) to the top or bottom of the rear bumper as shown in Figure 15.

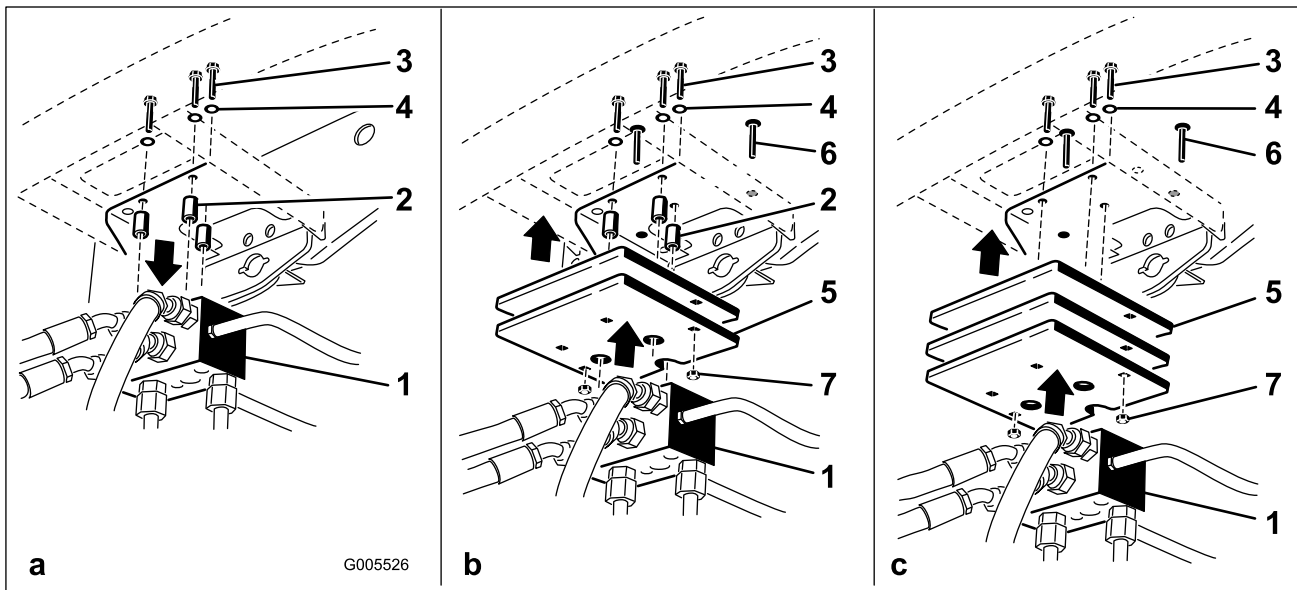

Figure 15

- 1. Traction manifold
- 2. Spacers
- 3. Bolts
- 4. Washers

- 5. Weight(s)
- 6. Carriage bolt
- 7. Nut

- Remove the 3 bolts, washers, and spacers securing the traction manifold to the bottom of the rear bumper (Figure 15a).
- Position the appropriate amount of weight on the top and/or bottom of the rear bumper.
- Mount the weight(s) and the traction manifold to the bumper with the 3 bolts, washers and spacers previously removed (Figure 15b).

Note: Do not use the spacers when installing more than two weights **under** the bumper (Figure 15c).

- Secure the outer edges of the weight(s) to the bumper with 2 carriage bolts and nuts (Figure 15c).

7

Installing the CE Hood Latch

Parts needed for this procedure:

1	Hood latch assembly
1	Washer

Procedure

1. Unlatch and raise the hood.
2. Remove the rubber grommet from the hole in the left side of the hood (Figure 16).

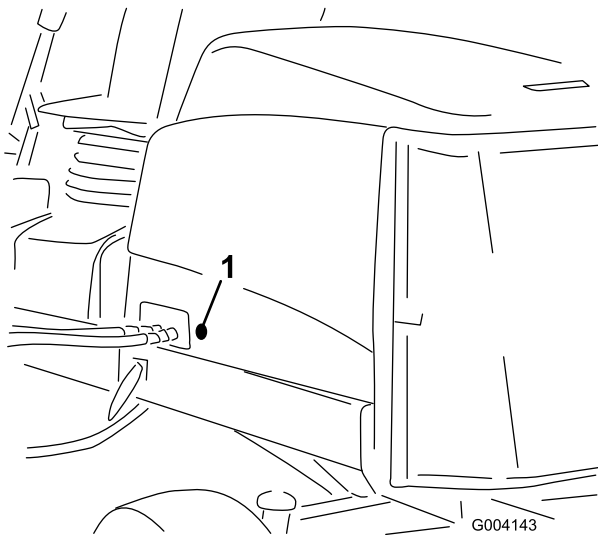

Figure 16

1. Rubber grommet

3. Remove the nut from the hood latch assembly (Figure 17).

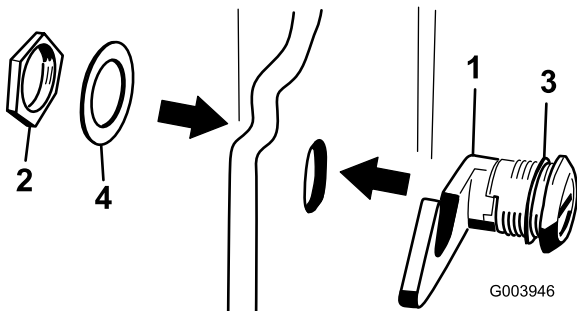

Figure 17

- | | |
|---------------|------------------|
| 1. Hood latch | 3. Rubber washer |
| 2. Nut | 4. Metal washer |

4. Outside the hood, insert the hook end of the latch through the hole in the hood. Make sure the rubber sealing washer remains to the outer side of the hood.
5. Inside the hood, insert the metal washer onto the latch and secure with the nut. Make sure the latch engages the frame catch when it is locked. Use the enclosed hood latch key to operate the hood latch.

8

Using the Cutting Unit Kickstand

Parts needed for this procedure:

1	Cutting unit kickstand
---	------------------------

Procedure

Whenever the cutting unit has to be tipped to expose the bedknife/reel, prop up the rear of the cutting unit with the kickstand to make sure the nuts on the back end of the bedbar adjusting screws are not resting on the work surface (Figure 18).

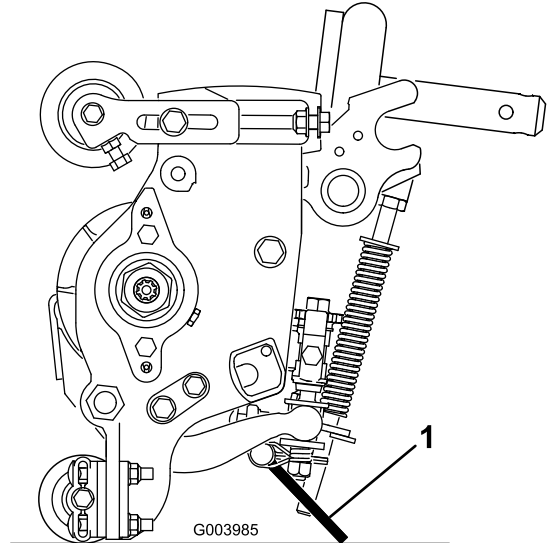

Figure 18

1. Cutting unit kickstand

Secure the kickstand to the chain bracket with the snapper pin (Figure 19).

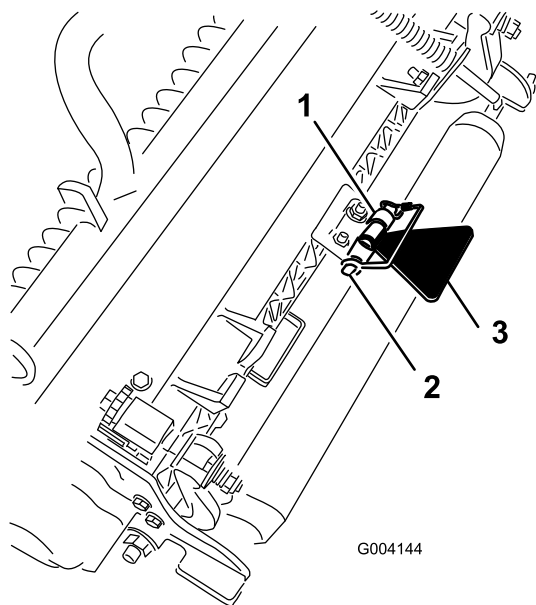

Figure 19

- 1. Chain bracket
- 2. Snapper pin
- 3. Cutting unit kickstand

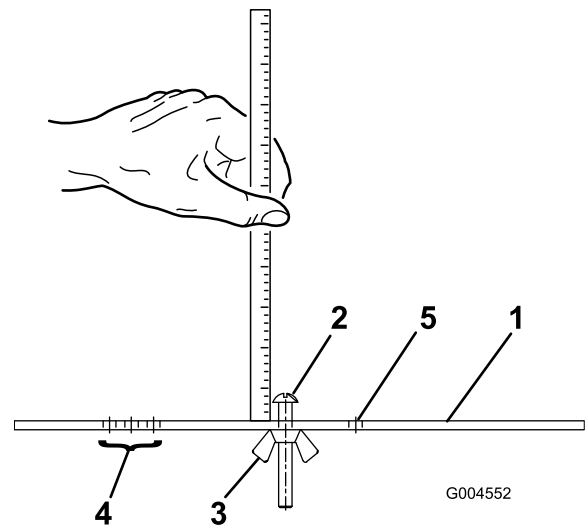

Figure 20

- 1. Gauge bar
- 2. Height adjusting screw
- 3. Nut
- 4. Holes used for setting Groomer HOG
- 5. Hole not used

9

Using the Gauge Bar

Parts needed for this procedure:

1	Gauge bar
---	-----------

Procedure

Use the gauge bar to adjust the cutting unit. Refer to the Cutting Unit Operator's Manual for the adjustment procedures (Figure 20).

10

Reading the Manual and Viewing the Safety Video

Parts needed for this procedure:

1	<i>Operator's Manual</i>
1	<i>Engine Operator's Manual</i>
1	<i>Parts Catalog</i>
1	CE certificate
1	Operator Training Material

Procedure

- Read the *Operator's Manual*.
- View the Operator Training Material.
- Store all documentation in a safe place for future use.
- Fill out the registration card.
- Use the diagnostic ACE display overlay when troubleshooting problems with the machine (store it in the service shop until needed).

Product Overview

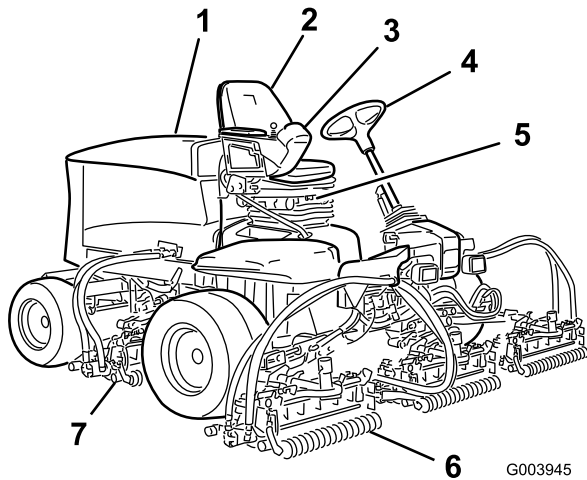

Figure 21

- | | |
|--------------------|------------------------|
| 1. Engine hood | 5. Seat |
| 2. Operator's seat | 6. Front cutting units |
| 3. Control arm | 7. Rear cutting units |
| 4. Steering wheel | |

Controls

Seat Adjusting Knobs

The seat adjusting lever (Figure 22) allows you to adjust the seat fore and aft. The weight adjusting knob adjusts the seat for the operator's weight. The weight gauge indicates when the seat is adjusted to the weight of the operator. The height adjusting knob adjusts the seat for the operator's height.

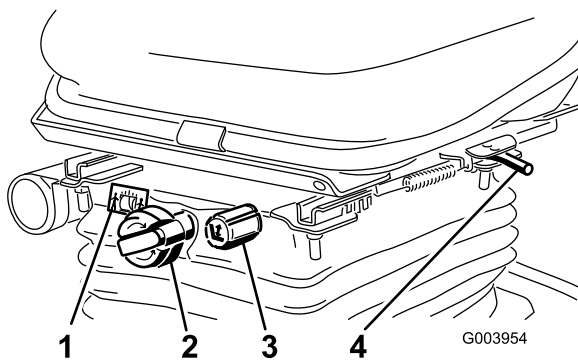

Figure 22

- | | |
|--------------------------|-----------------------------------|
| 1. Weight gauge | 3. Height adjusting knob |
| 2. Weight adjusting knob | 4. Adjusting lever (fore and aft) |

Traction Pedal

The traction pedal (Figure 23) controls the forward and reverse operation. Press the top of the pedal to move forward and the bottom to move rearward. Ground

speed depends on how far you press the pedal. For no load, maximum ground speed, fully press the pedal while the throttle is in the Fast position.

To stop, reduce foot pressure on the traction pedal and allow it to return to the center position.

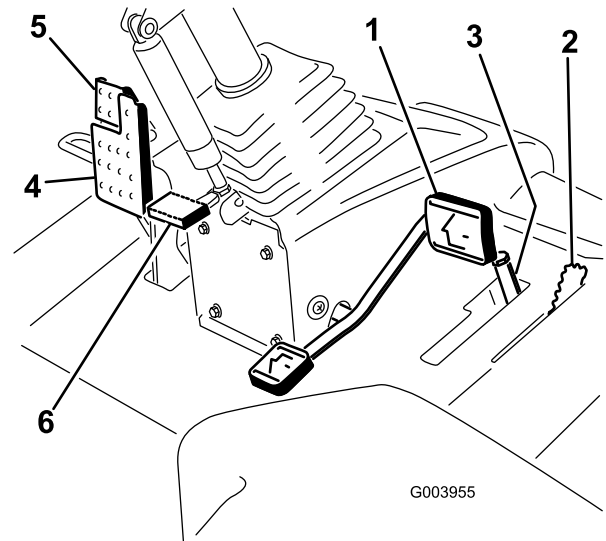

Figure 23

- | | |
|----------------------|------------------------|
| 1. Traction pedal | 4. Brake pedal |
| 2. Mow speed limiter | 5. Parking brake |
| 3. Spacers | 6. Tilt steering pedal |

Mow Speed Limiter

When the mow speed limiter (Figure 23) is flipped up it will control the mow speed and allow the cutting units to be engaged. Each spacer adjusts the mowing speed by ½ mile per hour. The more spacers you have, on the top of the bolt the slower you will go. For transport, flip back the mow speed limiter and you will have maximum transport speed.

Brake Pedal

Press the brake pedal (Figure 23) to stop the machine.

Parking Brake

To engage the parking brake, (Figure 23) push down on the brake pedal and press the top forward to latch. To release the parking brake, press the brake pedal until the parking brake latch retracts.

Tilt Steering Pedal

To tilt the steering wheel towards you, press the foot pedal (Figure 23) down, and pull the steering tower toward you to the most comfortable position and then release the pedal.

Throttle Control

Move the throttle control (Figure 24) forward to increase the engine speed and rearward to decrease speed.

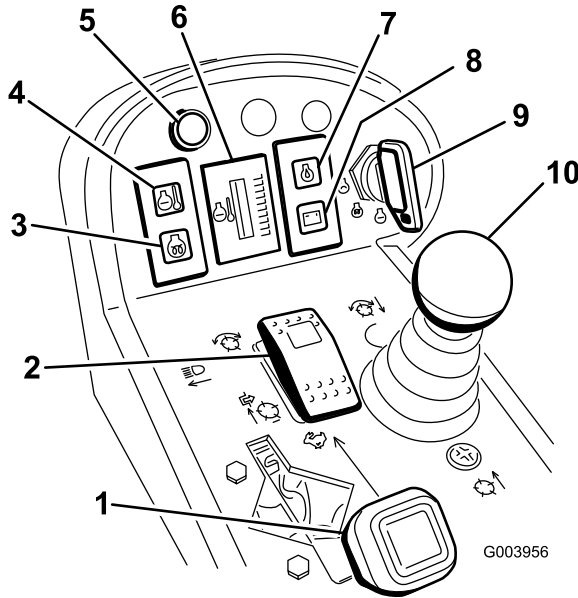

Figure 24

- | | |
|---|--------------------------------------|
| 1. Throttle control | 6. Engine coolant temperature gauge |
| 2. Enable/disable switch | 7. Engine oil pressure warning light |
| 3. Glow plug indicator light | 8. Charge indicator |
| 4. Engine coolant temperature warning light | 9. Key switch |
| 5. Diagnostic light | 10. Lower mow/raise control lever |

Key Switch

The key switch (Figure 24) has three positions: Off, On/Preheat, and Start.

Engine Coolant Temperature Warning Light

This light (Figure 24) illuminates and the reels shut down when the engine coolant reaches a high temperature. If the engine temperature continues to rise, the engine will shut down.

Engine Coolant Temperature Gauge

During normal operating conditions the gauge (Figure 24) should be in the green range. Check the cooling system if the gauge goes to the yellow or red range.

Diagnostic Light

It will illuminate should a system fault be recognized.

Lower Mow/Raise Control Lever

This lever (Figure 24) raises and lowers the cutting units and also starts and stops the reels when the reels are enabled in the mow mode.

Glow Plug Indicator Light

This light (Figure 24) illuminates when the glow plugs are preheating.

Engine Oil Pressure Warning Light

This light (Figure 24) indicates dangerously low engine oil pressure.

Charge Indicator

The charge indicator (Figure 24) illuminates when the system charging circuit malfunctions.

Enable/Disable Switch

Use the enable/disable switch (Figure 24) in conjunction with the lower mow/raise control lever to operate the reels. The reels cannot be lowered when the mow/transport lever is in the transport position.

Backlap Levers

Use the backlap levers in conjunction with the lower mow/raise control lever for backlapping the reels (Figure 25).

Reel Speed Controls

The reel speed controls control the speed of the front and rear cutting units (Figure 25). The reel speed increases as the knobs are turned counter clockwise.

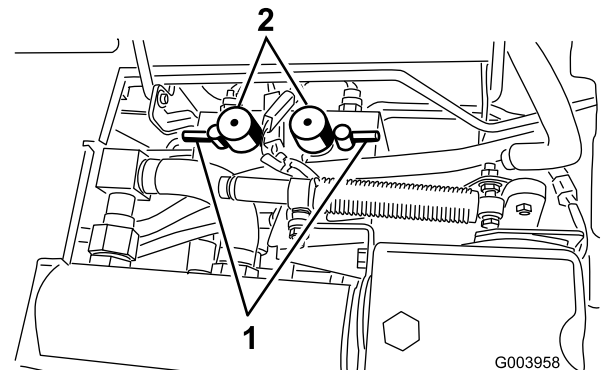

Figure 25

1. Backlap levers
2. Reel speed controls

Hour Meter

The hour meter (Figure 26) shows the total hours that the machine has been operated.

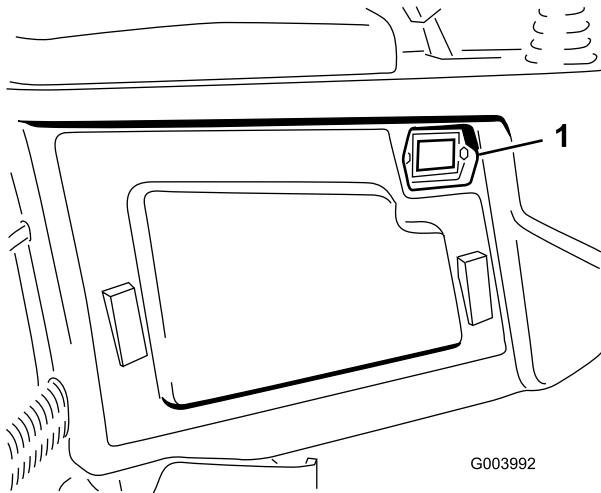

Figure 26

1. Hour meter

Hydraulic Filter Restriction Indicator

With the engine running at normal operating temperature, view the indicator (Figure 27), it should be in the Green zone. When the indicator is in the Red zone, change the hydraulic filters.

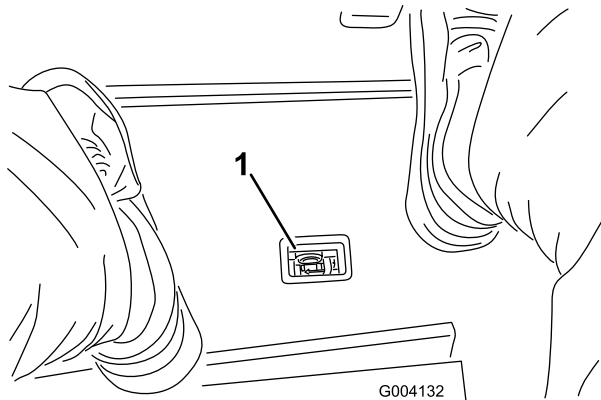

Figure 27

1. Hydraulic filter restriction indicator

Fuel Gauge

The fuel gauge (Figure 28) shows the amount of fuel in the tank.

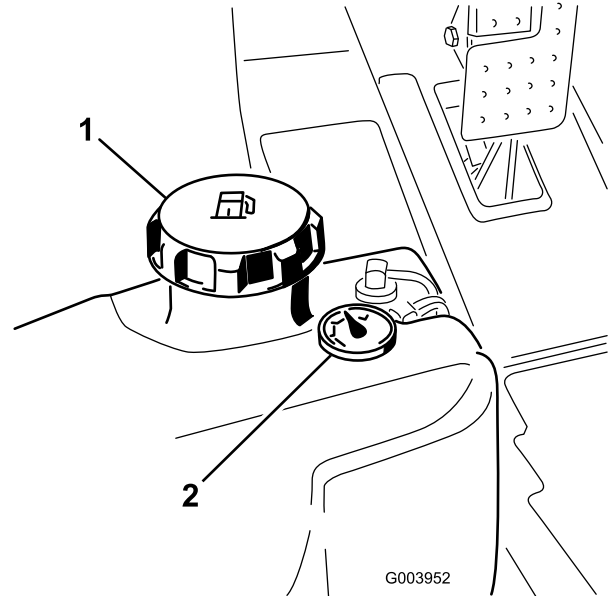

Figure 28

1. Fuel tank cap
2. Fuel gauge

Headlight Switch

Pivot the switch downward to turn on the headlights (Figure 29).

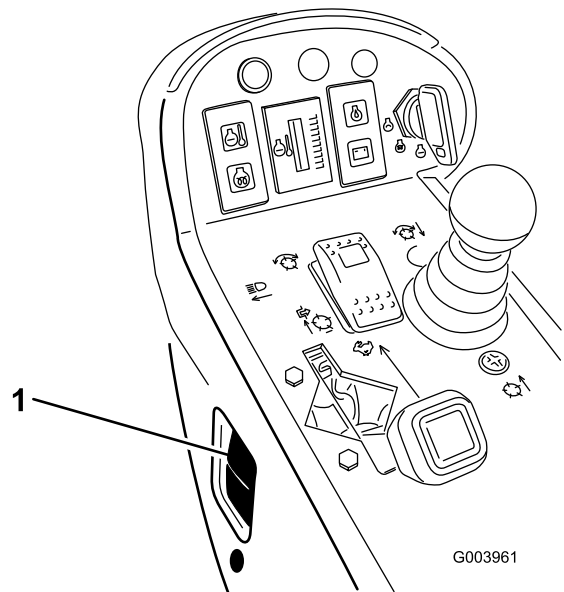

Figure 29

1. Headlight switch

Power Point

The power point is a 12 volt power supply for electronic devices (Figure 30).

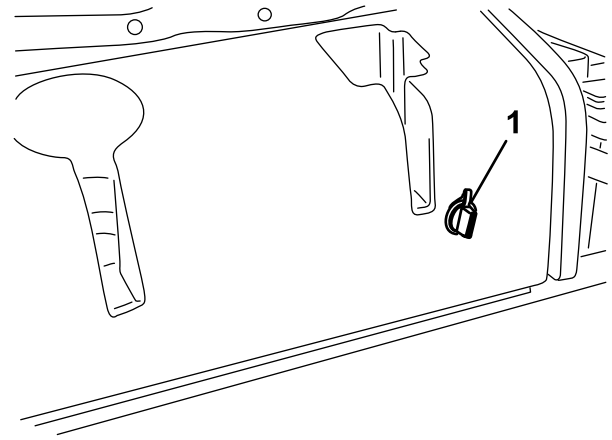

Figure 30

G004133

1. Power point

Specifications

Note: Specifications and design are subject to change without notice.

Specification	ReelMaster® 5210	ReelMaster® 5410	ReelMaster® 5510	ReelMaster® 5610
Transport Width	90 inches (228 cm)	90 inches (228 cm)	92 inches (233 cm)	92 inches (233 cm)
Width of cut	100 inches (254 cm)	100 inches (254 cm)	100 inches (254 cm)	100 inches (254 cm)
Length	111 inches (282 cm)	111 inches (282 cm)	111 inches (282 cm)	111 inches (282 cm)
Height	62 inches (157 cm)	63 inches (160 cm)	63 inches (160 cm)	63 inches (160 cm)
Weight	2,396 lb (1,087 kg)	2,505 lb (1,136 kg)	2,693 lb (1,222 kg)	2,813 lb (1,276 kg)
Engine	Kubota 28 hp	Kubota 35.5 hp	Kubota 35.5 hp	Kubota 44.2 hp (Turbo)
Fuel tank capacity	13.5 US gallons (51 l)	13.5 US gallons (51 l)	13.5 US gallons (51 l)	13.5 US gallons (51 l)
Transport speed	0–10 mph (0–16 kph)	0–10 mph (0–16 kph)	0–10 mph (0–16 kph)	0–10 mph (0–16 kph)
Mowing speed	0–8 mph (0–13 kph)	0–8 mph (0–13 kph)	0–8 mph (0–13 kph)	0–8 mph (0–13 kph)

Attachments/Accessories

A selection of Toro approved attachments and accessories are available for use with the machine to enhance and expand its capabilities. Contact your Authorized Service Dealer or Distributor or go to www.Toro.com for a list of all approved attachments and accessories.

Operation

Note: Determine the left and right sides of the machine from the normal operating position.



If you leave the key in the ignition switch, someone could accidentally start the engine and seriously injure you or other bystanders.

Lower the cutting units to the ground, set the parking brake and remove the key from the ignition switch before servicing or making adjustments to the machine.

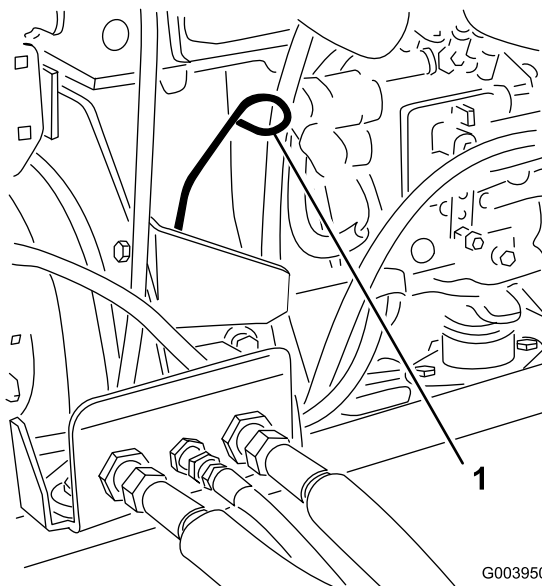

Figure 31

Checking the Engine Oil Level

The engine is shipped with oil in the crankcase; however, the oil level must be checked before and after the engine is first started.

Crankcase capacity for model 5210 is approximately 3.5 qt. (3.3 l) with the filter. Crankcase capacity for models 5410, 5510 and 5610 is approximately 5.5 qt. (5.2 l) with the filter.

Use high-quality engine oil that meets the following specifications:

- API Classification Level Required: CH-4, CI-4 or higher
- Preferred oil: SAE 15W-40 (above 0 degrees F)
- Alternate oil: SAE 10W-30 or 5W-30 (all temperatures)

Toro Premium Engine oil is available from your distributor in either 15W-40 or 10W-30 viscosity.

1. Park the machine on a level surface, stop the engine, set the parking brake and remove the key from the ignition switch.
2. Open the hood.
3. Remove the dipstick, wipe it clean, and install it (Figure 31).

1. Dipstick

4. Remove dipstick and check oil level on dipstick.

The oil level should be up to the Full mark .

5. If the oil level is below the Full mark, remove the fill cap (Figure 32) and add oil until level reaches the Full mark on dipstick.

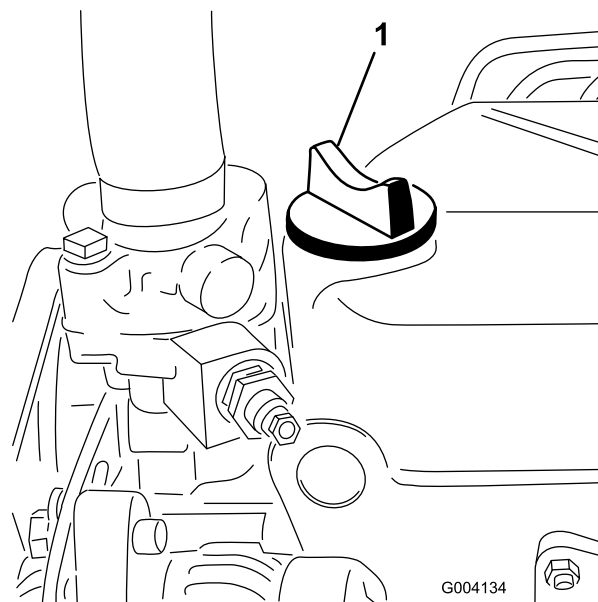

Figure 32

1. Oil fill cap

Do not overfill.

Important: Be sure to keep the engine oil level between the upper and lower limits on the oil

gauge. Engine failure may occur as a result of over filling or under filling the engine oil.

6. Install the oil fill cap and close the hood.

Checking the Cooling System

Clean debris off of the screen, oil cooler, and front of the radiator daily and more often if conditions are extremely dusty and dirty. Refer to the section on Removing Debris from the Cooling System in , page .

The cooling system is filled with a 50/50 solution of water and permanent ethylene glycol antifreeze. Check the level of coolant in the expansion tank at the beginning of each day before starting the engine. The capacity of the cooling system for the model 5210 is 5.5 quarts (5.2 l). The capacity for model 5410 is 7.0 quarts (6.6 l) and models 5510 5610 is 10.0 quarts (9.5 l).



If the engine has been running, the pressurized, hot coolant can escape and cause burns.

- Do not open the radiator cap when the engine is running.
- Use a rag when opening the radiator cap, and open the cap slowly to allow steam to escape.

1. Check the level of coolant in the expansion tank (Figure 33).

The coolant level should be between the marks on the side of the tank.

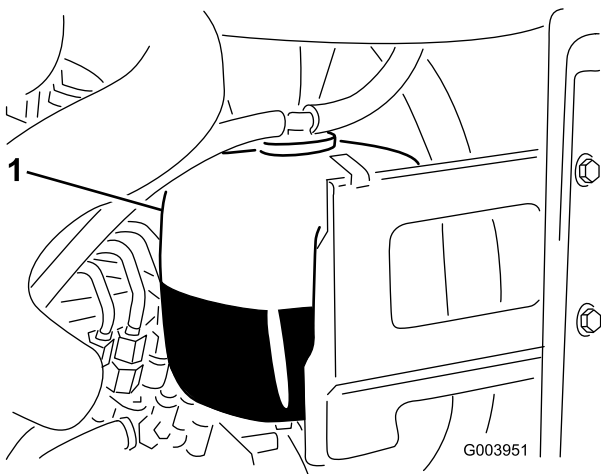

Figure 33

1. Expansion tank

2. If the coolant level is low, remove the expansion tank cap and replenish the system. **Do not overfill.**
3. Install the expansion tank cap.

Adding Fuel

Use only clean, fresh diesel fuel or biodiesel fuels with low (<500 ppm) or ultra low (<15 ppm) sulfur content. The minimum cetane rating should be 40. Purchase fuel in quantities that can be used within 180 days to ensure fuel freshness.

Fuel tank capacity: 13.5 gallons (51 l)

Use summer grade diesel fuel (No. 2-D) at temperatures above 20° F (-7° C) and winter grade (No. 1-D or No. 1-D/2-D blend) below that temperature. Use of winter grade fuel at lower temperatures provides lower flash point and cold flow characteristics which will ease starting and reduce fuel filter plugging.

Use of summer grade fuel above 20° F (-7° C) will contribute toward longer fuel pump life and increased power compared to winter grade fuel.

Important: Do not use kerosene or gasoline instead of diesel fuel. Failure to observe this caution will damage the engine.



Fuel is harmful or fatal if swallowed. Long-term exposure to vapors can cause serious injury and illness.

- Avoid prolonged breathing of vapors.
- Keep face away from nozzle and gas tank or conditioner opening.
- Keep fuel away from eyes and skin.

Biodiesel Ready

This machine can also use a biodiesel blended fuel of up to B20 (20% biodiesel, 80% petrodiesel). The petrodiesel portion should be low or ultra low sulfur. Observe the following precautions:

- The biodiesel portion of the fuel must meet specification ASTM D6751 or EN14214.
- The blended fuel composition should meet ASTM D975 or EN590.
- Painted surfaces may be damaged by biodiesel blends.
- Use B5 (biodiesel content of 5%) or lesser blends in cold weather.

- Monitor seals, hoses, gaskets in contact with fuel as they may be degraded over time.
- Fuel filter plugging may be expected for a time after converting to biodiesel blended.
- Contact your distributor if you wish for more information on biodiesel.



In certain conditions, fuel is extremely flammable and highly explosive. A fire or explosion from fuel can burn you and others and can damage property.

- Fill the fuel tank outdoors, in an open area, when the engine is cold. Wipe up any fuel that spills.
- Never fill the fuel tank inside an enclosed trailer.
- Never smoke when handling fuel, and stay away from an open flame or where fuel fumes may be ignited by a spark.
- Store fuel in an approved container and keep it out of the reach of children. Never buy more than a 30-day supply of fuel.
- Do not operate without entire exhaust system in place and in proper working condition.



In certain conditions during fueling, static electricity can be released causing a spark which can ignite the fuel vapors. A fire or explosion from fuel can burn you and others and can damage property.

- Always place fuel containers on the ground away from your vehicle before filling.
- Do not fill fuel containers inside a vehicle or on a truck or trailer bed because interior carpets or plastic truck bed liners may insulate the container and slow the loss of any static charge.
- When practical, remove equipment from the truck or trailer and refuel the equipment with its wheels on the ground.
- If this is not possible, then refuel such equipment on a truck or trailer from a portable container, rather than from a fuel dispenser nozzle.
- If a fuel dispenser nozzle must be used, keep the nozzle in contact with the rim of the fuel tank or container opening at all times until fueling is complete.

1. Park the machine on a level surface.
2. Using a clean rag, clean area around fuel tank cap.
3. Remove cap from the fuel tank (Figure 34).

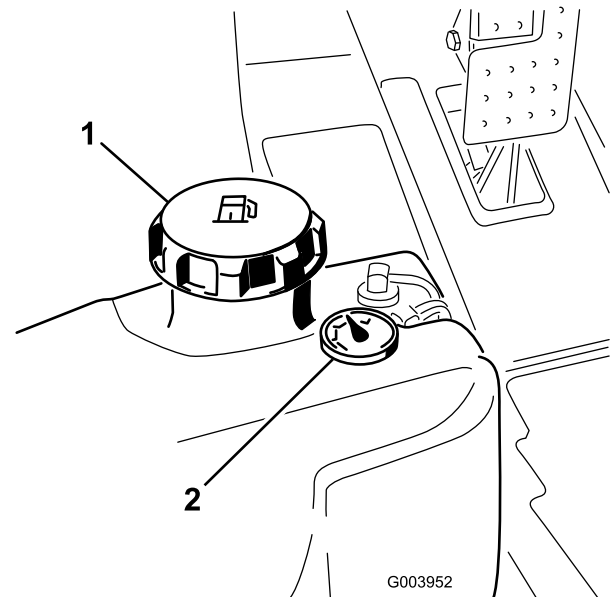

Figure 34

1. Fuel tank cap
2. Fuel gauge

4. Fill the tank until the level is to the bottom of the filler neck with diesel fuel.
5. Install fuel tank cap tightly after filling tank.

Note: If possible, fill the fuel tank after each use. This will minimize possible buildup of condensation inside the fuel tank.

Checking the Hydraulic Fluid

The machine's reservoir is filled at the factory with approximately 8 U.S. gallons (30 l) of high quality hydraulic fluid. Check the level of the hydraulic fluid before the engine is first started and daily thereafter. The recommended replacement fluid is as follows:

Toro Premium All Season Hydraulic Fluid (Available in 5 gallon pails or 55 gallon drums. See parts catalog or Toro distributor for part numbers.)

Alternate fluids: If the Toro fluid is not available, other fluids may be used provided they meet all the following material properties and industry specifications. We do not recommend the use of synthetic fluid. Consult with your lubricant distributor to identify a satisfactory product. **Note:** Toro will not assume responsibility for damage caused by improper substitutions, so use only products from reputable manufacturers who will stand behind their recommendation.

High Viscosity Index/Low Pour Point Anti-wear Hydraulic Fluid, ISO VG 46

Material Properties:

Viscosity, ASTM D445	cSt @ 40°C 44 to 48 cSt @ 100°C 7.9 to 8.5
Viscosity Index ASTM D2270	140 to 160

Pour Point, ASTM D97	-34°F to -49°F
----------------------	----------------

Industry Specifications:

Vickers I-286-S (Quality Level), Vickers M-2950-S (Quality Level), Denison HF-0

Note: Many hydraulic fluids are almost colorless, making it difficult to spot leaks. A red dye additive for the hydraulic system oil is available in 2/3 oz. (20 ml) bottles. One bottle is sufficient for 4-6 gal (15-22 l) of hydraulic oil. Order part no. 44-2500 from your authorized Toro distributor.

Biodegradable Hydraulic Fluid - Mobil 224H

Toro Biodegradable Hydraulic Fluid (Available in 5 gallon pails or 55 gallon drums. See parts catalog or Toro distributor for part numbers.)

Alternate fluid: Mobil EAL 224H

Note: This is vegetable-oil based biodegradable oil tested and approved by Toro for this model. This fluid is not as resistant to high temperatures as standard fluid, so be sure to follow the recommended fluid change intervals with this fluid. Contamination

by mineral-based hydraulic fluids will change the biodegradability and toxicity of this oil. When changing from standard fluid to the biodegradable type, be certain to follow the approved flushing procedure. Contact your local Toro Distributor for details.

1. Position machine on a level surface, lower the cutting units and stop the engine.
2. On the right side of the machine, raise the hydraulic tank cover (Figure 35).

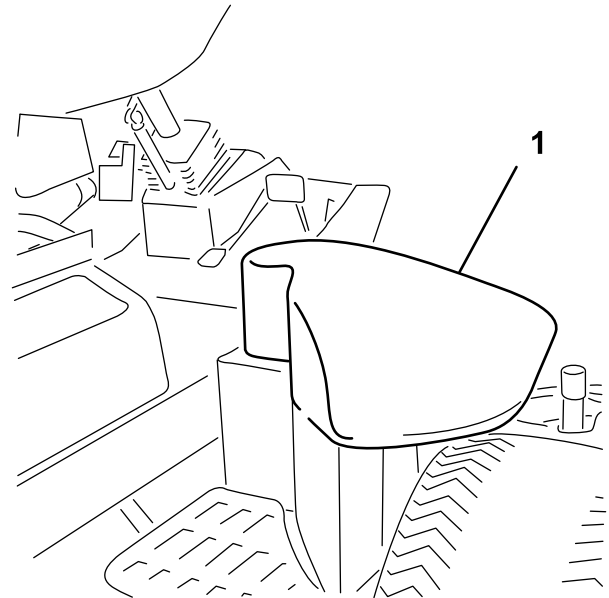

Figure 35

1. Hydraulic tank cover
3. Clean area around filler neck and cap of hydraulic tank (Figure 36). Remove cap from filler neck.

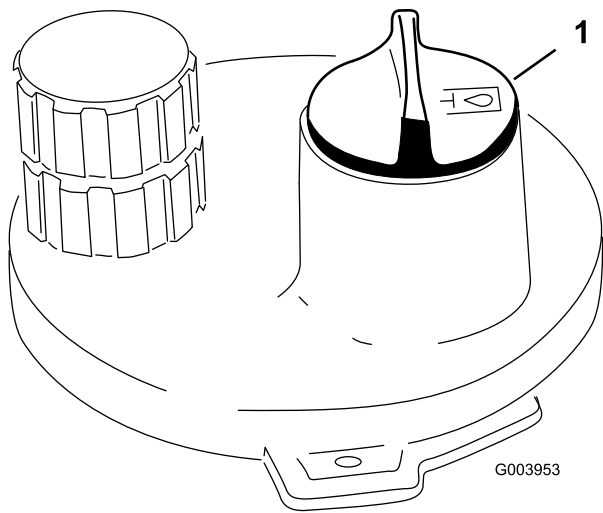

Figure 36

1. Hydraulic tank cap

4. Remove dipstick from filler neck and wipe it with a clean rag. Insert dipstick into filler neck; then remove it and check level of fluid. Fluid level should be 1/4 inch of mark on dipstick. Do not overfill.
5. If level is low, add appropriate fluid to raise level to full mark.
6. Install dipstick and cap onto filler neck.

Checking the Reel to Bedknife Contact

Each day before operating, check reel to bedknife contact, regardless if the quality of cut had previously been acceptable. There must be light contact across the full length of the reel and the bedknife (refer to Adjusting the Reel to Bedknife in the cutting unit *Operator's Manual*).

Check the Torque of the Wheel Nuts

Torque the wheel nuts to 70 to 90 ft-lb (94 to 122 N·m). after **1-4 hours** of operation and again after **10 hours** of operation. Torque every **250 hours** thereafter.



Failure to maintain proper torque of the wheel nuts could result in personal injury.

Bleeding the Fuel System

You must bleed the fuel system before starting the engine if any of the following situations have occurred:

- Initial start up of a new machine.
- Engine has ceased running due to lack of fuel.
- Maintenance has been performed upon fuel system components; i.e., filter replaced, separator serviced, etc.



Under certain conditions, diesel fuel and fuel vapors are highly flammable and explosive. A fire or explosion from fuel can burn you and others and can cause property damage.

- Use a funnel and fill the fuel tank outdoors, in an open area, when the engine is off and is cold. Wipe up any fuel that spills.
- Do not fill the fuel tank completely full. Add fuel to the fuel tank until the level is 1/4 to 1/2 in. (6 to 13 mm) below the bottom of the filler neck. This empty space in the tank allows the fuel to expand.
- Never smoke when handling fuel, and stay away from an open flame or where fuel fumes may be ignited by a spark.
- Store fuel in a clean, safety-approved container and keep the cap in place.

1. Park the machine on a level surface and ensure that the fuel tank is at least half full.
2. Open the hood.
3. Open the air bleed screw on the fuel injection pump (Figure 37) with a 12 mm wrench.

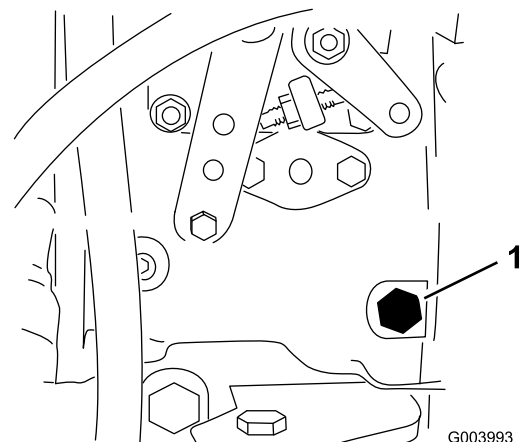

Figure 37

1. Bleed screw

4. Turn the key in the ignition switch to the On position. The electric fuel pump will begin operation, thereby forcing air out around the air

bleed screw. Leave the key in the On position until a solid stream of fuel flows out around the screw.

5. Tighten the screw and turn the key to the Off position.

Note: Normally, the engine should start after the above bleeding procedures are followed. However, if engine does not start, air may be trapped between injection pump and injectors; refer to Bleeding Air from the Injectors in , page .

Starting and Stopping the Engine

Important: You must bleed the fuel system before starting the engine if you are starting the engine for the first time, the engine has stopped due to lack of fuel, or you have performed maintenance on the fuel system; refer to Bleeding the Fuel System.

Starting the Engine

1. Sit on the seat, keep your foot off of the traction pedal so that it is in Neutral, engage the parking brake, set the throttle to the Fast position, and ensure that the Enable/Disable switch is in the Disable position.
2. Turn the ignition switch to the On/Preheat position.
An automatic timer will control the glow plug preheat for 6 seconds.
3. After preheating the glow plugs, turn key to the Start position.

Crank the engine for no longer than 15 seconds. Release the key when the engine starts. If additional preheating is required, turn key to the Off position and then to the On/Preheat position. Repeat this process as required.

4. Run the engine at low idle speed until it warms up.

Stopping the Engine

1. Move all controls to Neutral, set the parking brake, move the throttle to the low idle position and allow the engine to reach low idle speed.

Important: Allow the engine to idle for 5 minutes before shutting it off after a full load operation. Failure to do so may lead to trouble on a turbo-charged engine.

2. Turn the key to the Off position and remove it from the switch.

Setting the Reel Speed

To achieve a consistent, high quality-of-cut and a uniform after cut appearance, it is important that you set the reel speed controls (located under the seat) correctly. Adjust the reel speed controls as follows:

1. Select the height-of-cut at which the cutting units are set.
2. Choose the desired ground speed best suited for conditions.
3. Using the appropriate graph on decal 110–0996 (Figure 39) for Reelmaster 5510 & 5610, 7 inch reel cutting units or decal 110–8923 (Figure 40) for Reelmaster 5210 & 5410, 5 inch reel cutting units determine the proper reel speed setting.

To set the reel speed, rotate knobs (Figure 38) until the indicator arrows are in line with the number designating the desired setting.

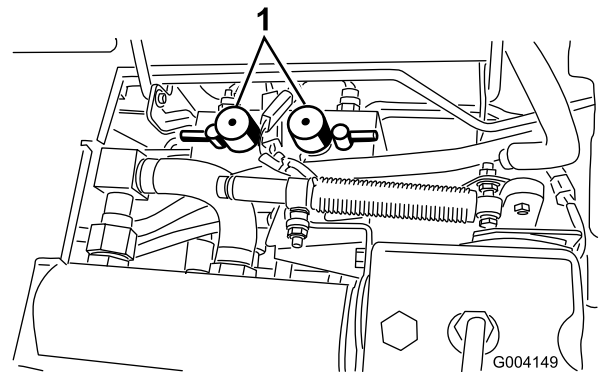

Figure 38

1. Reel speed control knobs

Note: The reel speed can be increased or decreased to compensate for turf conditions.



The springs are under tension.
Use caution when adjusting them.

3. While relieving the spring tension, remove the bolt and locknut securing the spring actuator to the bracket (Figure 41).

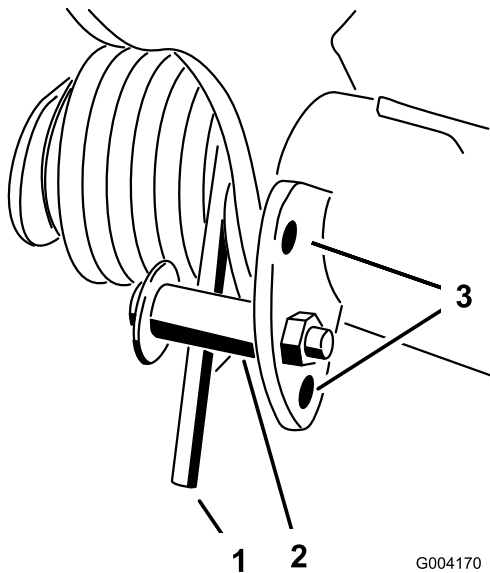

Figure 41

1. Spring
2. Spring actuator
3. Hole locations

4. Move the spring actuator to the desired hole location and secure with locknut.
5. Repeat the procedure on the remaining spring.

Adjusting the Lift Arm Turn Around Position

1. Position the machine on a level surface, lower the cutting units, stop the engine, engage the parking brakes, and remove the key from ignition switch.
2. The lift arm switch is located underneath the hydraulic tank behind the front right lift arm (Figure 42).
3. Loosen the switch mounting screws (Figure 42) and move the switch down to increase the lift arm turn around height or move the switch up to decrease the lift arm turn around height. Tighten the mounting screws.

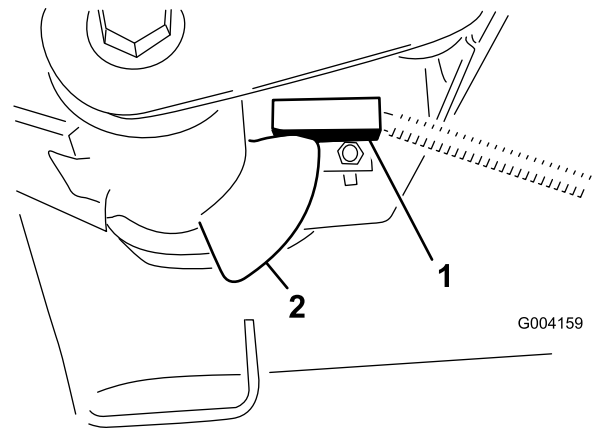

Figure 42

1. Switch
2. Lift arm sensing device

Pushing or Towing the Machine

In an emergency, the machine can be moved by actuating the bypass valve in the variable displacement hydraulic pump and pushing or towing the machine.

Important: Do not push or tow the machine faster than 2-3 mph (3-4.8 km/h) because internal transmission damage may occur. The bypass valve must be open whenever the machine is pushed or towed.

1. The bypass valve is located on the left side of the hydrostat (Figure 43). Rotate the bolt 1-1/2 turns to open and allow oil to bypass internally. Because fluid is bypassed, the machine can be moved slowly without damaging the transmission.

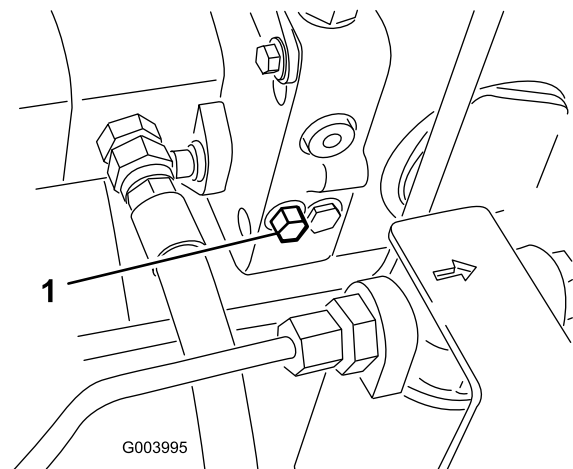

Figure 43

1. Bypass valve
2. Close the bypass valve before starting the engine. However, do not exceed 5-8 ft.-lb. (7-11 N m) torque to close the valve.

Important: Running the engine with the bypass valve open will cause the transmission to overheat.

Jacking Points

Note: Use jack stands to support the machine when required.

- Front—rectangular pad, under the axle tube, inside each front tire (Figure 44).

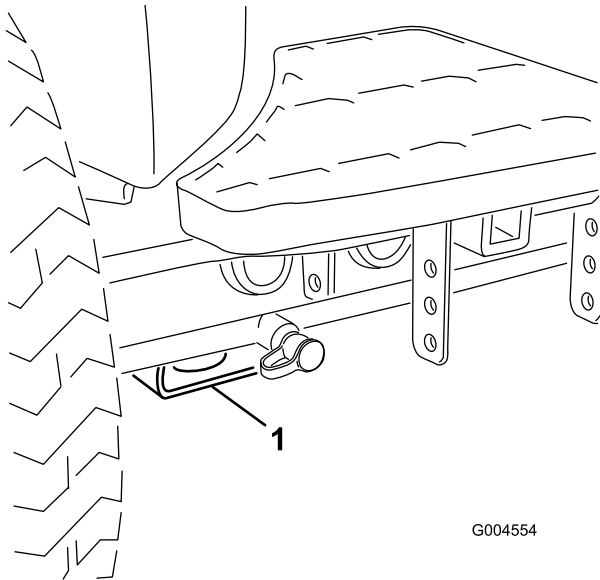

Figure 44

1. Front jacking point

- Rear—rectangular axle tube on the rear axle.

Tie Downs

- Front—the hole in the rectangular pad, under the axle tube, inside each front tire (Figure 45).

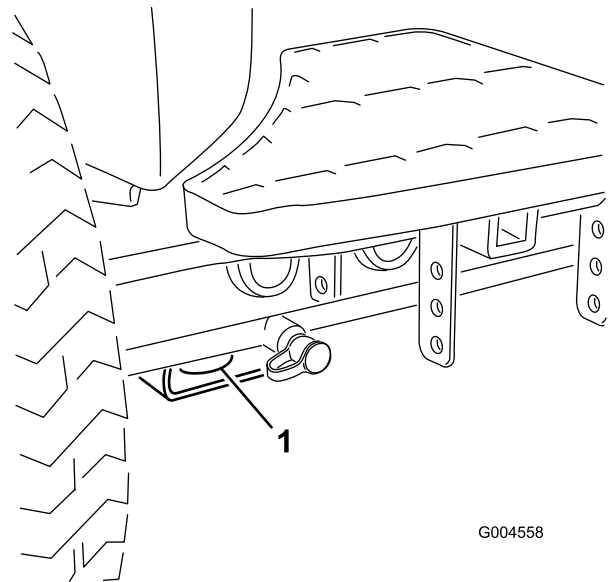

G004558

Figure 45

1. Front tie down

- Rear—each side of the machine on the rear frame (Figure 46).

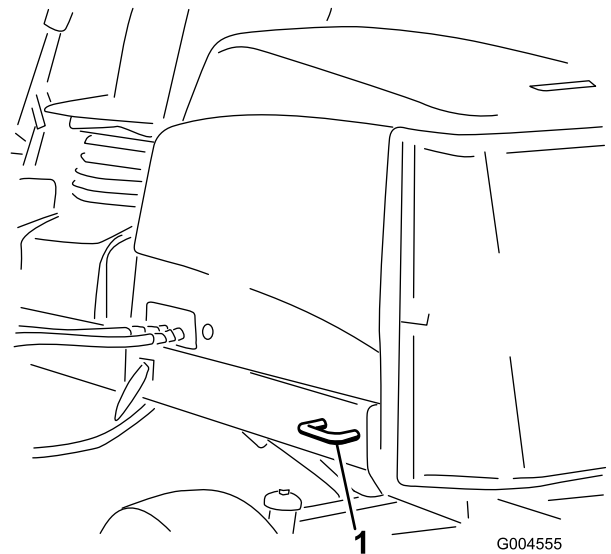

G004555

Figure 46

1. Rear tie down

Understanding the Diagnostic Light

The machine is equipped with a diagnostic light which indicates if the electronic controller senses an electronic malfunction. The diagnostic light is located on the control arm (Figure 47). When the electronic controller is functioning correctly and the key switch is moved to the On position, the controller diagnostic light will turn ON for 3 seconds and turn OFF to indicate the light is working properly. If the machine kills the light will

turn on steady until the key position is changed. The light will blink if the controller detects a malfunction in the electrical system. The light will stop blinking and automatically reset when the key switch is turned to the Off position once the fault has been resolved.

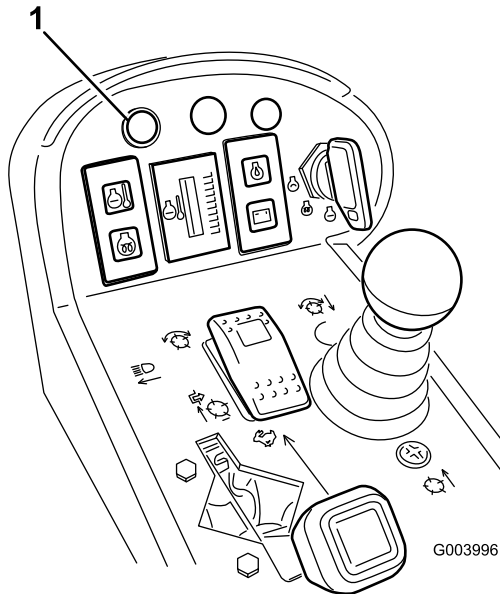

Figure 47

1. Diagnostic light

When the controller diagnostic light blinks, one of the following problems has been detected by the controller:

- One of the outputs has been shorted.
- One of the outputs is open circuited.

Using the diagnostic display, determine which output is malfunctioning; refer to Checking the Interlock Switches.

If the diagnostic light is not illuminated when the key switch is in the On position, this indicates that the electronic controller is not operating. Possible causes are as follows:

- Loop-back is not connected.
- The light is burned out.
- Fuses are blown.
- It is not functioning correctly.

Check the electrical connections, input fuses, and diagnostic light bulb to determine the malfunction. Ensure that the loop-back connector is secured to the wire harness connector.

Diagnostic Ace Display

The machine is equipped with an electronic controller which controls most machine functions. The controller determines what function is required for various input switches (i.e. seat switch, key switch, etc.) and turns on the outputs to actuate solenoids or relays for the requested machine function.

For the electronic controller to control the machine as desired, each of the input switches, output solenoids, and relays must be connected and functioning properly.

Use the Diagnostic ACE display to help verify and correct electrical functions of the machine.

Checking the Interlock Switches

The purpose of the interlock switches is to prevent the engine from cranking or starting unless the traction pedal is in the Neutral position, the Enable/Disable switch is in the Disable position, and the Lower Mow/Raise control is in the Neutral position. In addition, the engine should stop when the traction pedal is pressed with operator off of the seat or if the parking brake is left engaged.



If safety interlock switches are disconnected or damaged the machine could operate unexpectedly causing personal injury.

- **Do not tamper with the interlock switches.**
- **Check the operation of the interlock switches daily and replace any damaged switches before operating the machine.**

Verifying the Interlock Switch Function

1. Park the machine on a level surface, lower the cutting units, stop the engine, and engage the parking brake.
2. Remove the access panel from the side of the control arm.
3. Locate the wire harness and connectors near the controller (Figure 48).

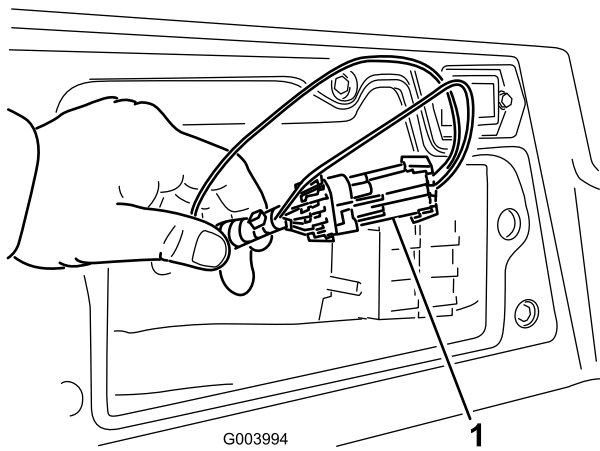

Figure 48

1. Wire harness and connectors

4. Carefully unplug loop back connector from harness connector.
5. Connect the Diagnostic ACE display connector to the harness connector (Figure 49).

Note: Make sure correct overlay decal is positioned on Diagnostic ACE display.

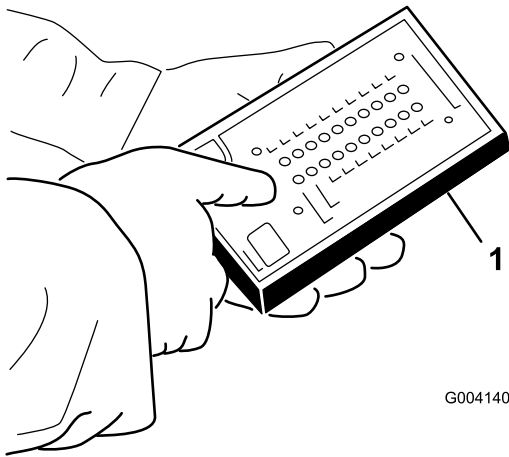

Figure 49

1. Diagnostic ACE

6. Turn the key switch to the On position, but do not start the machine.

Note: The red text on the overlay decal refers to input switches and the green text refers to outputs.

7. The “inputs displayed” LED, on the lower right column of the Diagnostic ACE, should be illuminated. If the “outputs displayed” LED is illuminated, press the toggle button, on Diagnostic ACE, to change LED to “inputs displayed”.

The Diagnostic ACE will illuminate the LED associated with each of the inputs when that input switch is closed.

8. Individually, change each of the switches from open to closed (i.e., sit on seat, engage traction pedal, etc.), and note that the appropriate LED on Diagnostic ACE will blink on and off when corresponding switch is closed. Repeat this for all switches that you can change by hand.
9. If a switch is closed and the appropriate LED does not turn on, check all wiring and connections to the switch and/or check the switches with an ohm meter. Replace any defective switches and repair any defective wiring.

Note: The Diagnostic ACE also has the ability to detect which output solenoids or relays are turned on. This is a quick way to determine if a machine malfunction is electrical or hydraulic.

Verifying Output Function

1. Park the machine on a level surface, lower the cutting units, stop the engine, and engage the parking brake.
2. Remove the access panel from the side of the control arm.
3. Locate wire harness and connectors near controller.
4. Carefully unplug loopback connector from harness connector.
5. Connect the Diagnostic ACE connector to the harness connector.

Note: Make sure correct overlay decal is positioned on Diagnostic ACE.

6. Turn the key switch to the ON position, but do not start machine.

Note: The red text on the overlay decal refers to input switches and the green text refers to outputs.

7. The “outputs displayed” LED, on lower right column of Diagnostic ACE, should be illuminated. If the “inputs displayed” LED is illuminated, press the toggle button, on the Diagnostic ACE, to change the LED to “outputs displayed”.

Note: It may be necessary to toggle between “inputs displayed” and “outputs displayed” several times to do the following step. To toggle back and forth, press the toggle button once. This may be done as often as required. Do not hold the button.

8. Sit on the seat and attempt to operate the desired function of the machine. The appropriate output LEDs should illuminate to indicate that the ECM is turning on that function.

Note: If the correct output LEDs do not illuminate, verify that the required input switches are in the necessary positions to allow that function to occur. Verify correct switch function.

If the output LEDs are on as specified, but the machine does not function properly, this indicates a non-electrical problem. Repair as necessary.

Note: If each output switch is in the correct position and functioning correctly, but the output LEDs are not correctly illuminated, this indicates an ECM problem. If this occurs, contact your Toro Distributor for assistance.

Important: The Diagnostic ACE display must not be left connected to the machine. It is not designed to withstand the environment of the machine's every day use. When done using the Diagnostic ACE, disconnect it from the machine and connect loop-back connector to harness connector. The machine will not operate without loopback connector installed on the harness. Store the Diagnostic ACE in dry, secure location in the shop, not on the machine.

Hydraulic Valve Solenoid Functions

Use the list below to identify and describe the different functions of the solenoids in the hydraulic manifold. Each solenoid must be energized to allow function to occur.

Solenoid	Function
MSV2	Front reel circuit
MSV1	Rear reel circuit
SVRV	Lift/lower cutting units
SV1	Lift/lower front cutting unit
SV3	Lift/lower rear cutting unit
SV2	Raise any cutting units

Operating Tips

Familiarization

Before mowing grass, practice operating the machine in an open area. Start and stop the engine. Operate in forward and reverse. Lower and raise the cutting units and engage and disengage the reels. When you feel familiar with the machine, practice operating up and down slopes at different speeds.

Warning System

If a warning light comes on during operation, stop the machine immediately and correct the problem before continuing operation. Serious damage could occur if you operate the machine with a malfunction.

Mowing

Start the engine and move the throttle to the Fast position. Move the Enable/Disable switch to the Enable position and use the Lower Mow/Raise lever to control the cutting units (the front cutting units are timed to lower before the rear cutting units). To move forward and cut grass, press the traction pedal forward.

Note: Allow the engine to idle for 5 minutes before shutting it off after a full load operation. Failure to do so may lead to turbo-charger trouble.

Transport

Move the Enable/Disable switch to the Disable position and raise the cutting units to the transport position. Move the Mow/Transport lever to the transport position. Be careful when driving between objects so you do not accidentally damage the machine or cutting units. Use extra care when operating the machine on slopes. Drive slowly and avoid sharp turns on slopes to prevent roll overs. Lower the cutting units when going downhill for steering control.

Maintenance

Note: Determine the left and right sides of the machine from the normal operating position.

Recommended Maintenance Schedule(s)

Maintenance Service Interval	Maintenance Procedure
After the first hour	<ul style="list-style-type: none"> • Torque the wheel lug nuts to 70 to 90 ft-lb (94 to 122 N·m).
After the first 8 hours	<ul style="list-style-type: none"> • Check the condition and tension of the alternator belt.
After the first 10 hours	<ul style="list-style-type: none"> • Torque the wheel lug nuts to 70 to 90 ft-lb (94 to 122 N·m). • Check and adjust the brake cables to equalize the engagement.
After the first 50 hours	<ul style="list-style-type: none"> • Change the engine oil and filter. • Check the engine RPM (idle and full throttle).
Before each use or daily	<ul style="list-style-type: none"> • Check the engine oil level. • Check the cooling system. • Check the hydraulic fluid level. • Check the reel to bedknife contact. • Check the operation of the interlock switches. • Remove debris from the screen, oil coolers, and radiator (more frequently in dirty operating conditions). • Check the hydraulic lines and hoses for leaks, kinked lines, loose mounting supports, wear, loose fittings, weather deterioration, and chemical deterioration.
Every 50 hours	<ul style="list-style-type: none"> • Grease the bearings and bushings. (Grease them immediately after every washing regardless of the interval listed.) • Check the condition of and clean the battery. • Check the battery cable connections.
Every 100 hours	<ul style="list-style-type: none"> • Inspect the cooling system hoses. • Check the condition and tension of the alternator belt.
Every 150 hours	<ul style="list-style-type: none"> • Change the engine oil and filter.
Every 200 hours	<ul style="list-style-type: none"> • Drain moisture from the fuel and hydraulic fluid tanks. • Check the reel bearing preload.
Every 250 hours	<ul style="list-style-type: none"> • Torque the wheel lug nuts to 70 to 90 ft-lb (94 to 122 N·m).
Every 400 hours	<ul style="list-style-type: none"> • Service the air cleaner. (Service the air cleaner earlier if the air cleaner indicator shows red. Service it more frequently in extremely dirty or dusty conditions.) • Check the fuel lines and connections for deterioration, damage, or loose connections. • Replace the fuel filter canister. • Check the engine RPM (idle and full throttle).
Every 800 hours	<ul style="list-style-type: none"> • Drain and clean the fuel tank • Check the rear wheel toe-in. • Change the hydraulic fluid. • Change the hydraulic filters (sooner if the service interval indicator is in the Red zone). • Pack the rear wheel bearings • Adjust the engine valves (refer to the engine Operator's Manual)
Before storage	<ul style="list-style-type: none"> • Drain and clean the fuel tank
Every 2 years	<ul style="list-style-type: none"> • Flush and replace the cooling system fluid. • Drain and flush the hydraulic tank. • Replace all moving hoses.

Daily Maintenance Checklist

Duplicate this page for routine use.

Maintenance Check Item	For the week of:						
	Mon.	Tues.	Wed.	Thurs.	Fri.	Sat.	Sun.
Check the safety interlock operation.							
Check the brake operation.							
Check the engine oil and fuel level.							
Drain the water/fuel separator.							
Check the air filter restriction indicator.							
Check the radiator and screen for debris.							
Check unusual engine noises. ¹							
Check unusual operating noises.							
Check the hydraulic system oil level.							
Check the hydraulic filter indicator. ²							
Check hydraulic hoses for damage.							
Check for fluid leaks.							
Check the tire pressure.							
Check the instrument operation.							
Check the reel-to-bedknife adjustment.							
Check the height-of-cut adjustment.							
Check all grease fittings for lubrication. ³							
Touch-up damaged paint.							
<p>1. Check the glow plug and injector nozzles if hard starting, excess smoke, or rough running is noted.</p> <p>2. Check with the engine running and the oil at operating temperature</p> <p>3. Immediately after every washing, regardless of the interval listed</p>							

Notation for Areas of Concern

Inspection performed by:		
Item	Date	Information
1		
2		
3		
4		
5		
6		
7		
8		

Important: Refer to your *Engine Operator's Manual* for additional maintenance procedures.

Service Interval Chart

REELMASTER 5210 / 5410 / 5510 / 5610

QUICK REFERENCE AID

CHECK/SERVICE (daily)

1. OIL LEVEL, ENGINE
2. OIL LEVEL, HYDRAULIC TANK
3. COOLANT LEVEL, RADIATOR
4. FUEL /WATER SEPARATOR
5. PRECLEANER -- AIR CLEANER

6. RADIATOR SCREEN
7. BRAKE FUNCTION
8. TIRE PRESSURE
9. BATTERY
10. BELTS (FAN, ALT.)

GREASING – SEE OPERATOR'S MANUAL



FLUID SPECIFICATIONS/CHANGE INTERVALS

SEE OPERATOR'S MANUAL FOR INITIAL CHANGES.	FLUID TYPE	CAPACITY	CHANGE INTERVAL		FILTER PART NO.
			FLUID	FILTER	
A. ENGINE OIL	SAE 15W-40CI-4	3.5 QTS.* (5210)	150 HRS.	150 HRS.	104-5167
		5.5 QTS.* (5410) (5510) (5610)			
B. HYD. CIRCUIT OIL	ISO VG 46/68	9 GALS.*	800 HRS.	SEE INDICATOR 800 HRS.	94-2621 86-3010
C. AIR CLEANER				SEE INDICATOR	108-3810 (5210) (5410) (5510) 108-3812 (5610)
D. WATER SEPARATOR				400 HRS.	110-9049
E. FUEL TANK	NO. 2-DIESEL	14 GALS.	DRAIN AND FLUSH, 2 YRS.		
F. COOLANT	50/50 ETHYLENE GLYCOL/WATER	5.5 QTS. (5210)	DRAIN AND FLUSH, 2 YRS.		
		7.0 QTS. (5410)			
		10.0 QTS. (5610)			

* INCLUDING FILTER

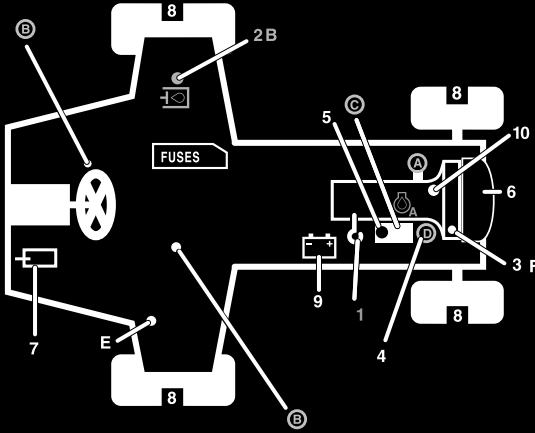

114-0429

Figure 50



If you leave the key in the ignition switch, someone could accidentally start the engine and seriously injure you or other bystanders.

Remove the key from the ignition before you do any maintenance.

Lubrication

Greasing the Bearings and Bushings

If you operate the machine under normal conditions, lubricate all grease fittings for the bearings and bushings after **every 50 hours of operation** with No. 2 General Purpose Lithium Base Grease. Lubricate bearings and bushings **immediately** after every washing, regardless of the interval listed.

The grease fitting locations and quantities are as follows:

- Pump drive shaft U-joint (3) (Figure 51)

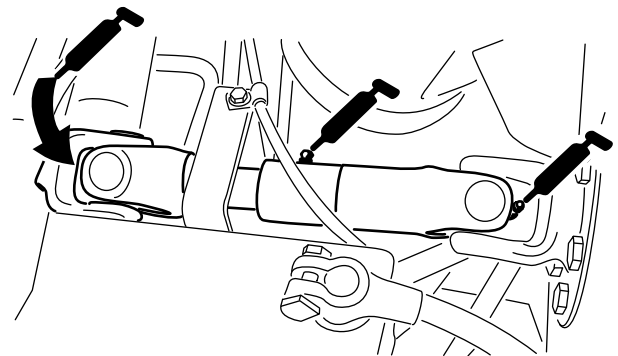

Figure 51

- Cutting unit lift arm cylinders (2 each) (Figure 52)

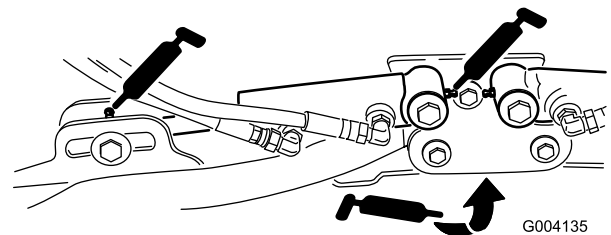

Figure 52

G004135

- Lift arm pivots (1 each) (Figure 52)
- Cutting unit carrier frame and pivot (2 each) (Figure 53)

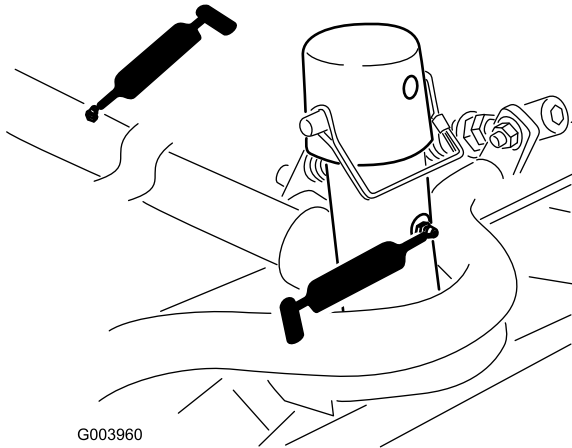

Figure 53

- Lift arm pivot shaft (1 each) (Figure 54)

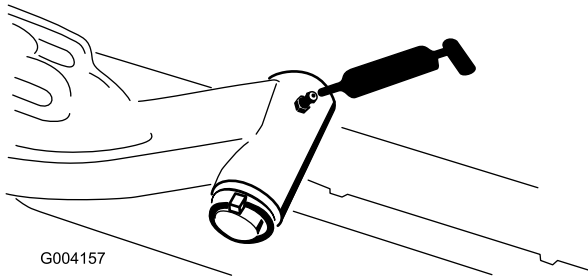

Figure 54

- Rear axle tie rod (2) (Figure 55)

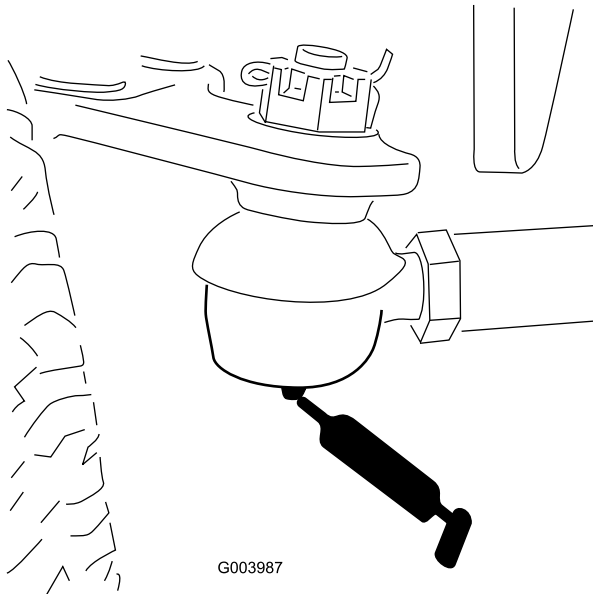

Figure 55

- Axle steering pivot (1) (Figure 56)

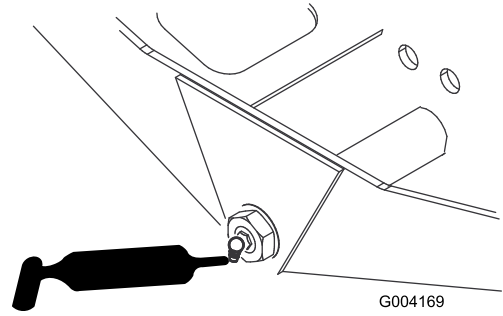

Figure 56

- Steering cylinder ball joints (2) (Figure 57)

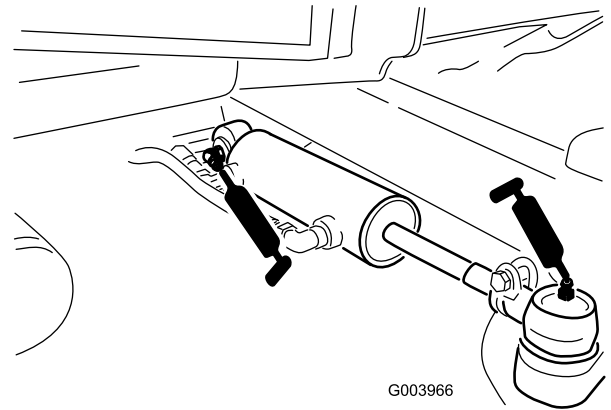

Figure 57

- Brake pedal (1) (Figure 58)

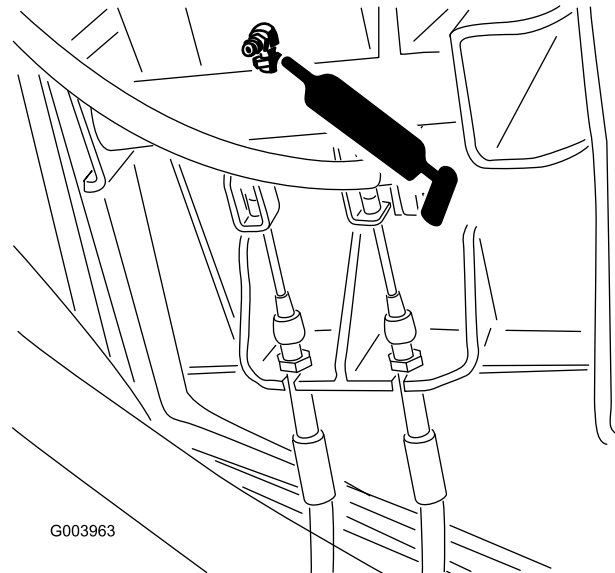

Figure 58

Engine Maintenance

Servicing the Air Cleaner

Check the air cleaner body for damage which could cause an air leak. Replace if damaged. Check the whole intake system for leaks, damage or loose hose clamps.

Service the air cleaner filter only when the service indicator (Figure 59) requires it. Changing the air filter before it is necessary only increases the chance of dirt entering the engine when the filter is removed.

Important: Be sure the cover is seated correctly and seals with the air cleaner body.

1. Release the latches securing the air cleaner cover to the air cleaner body (Figure 59).

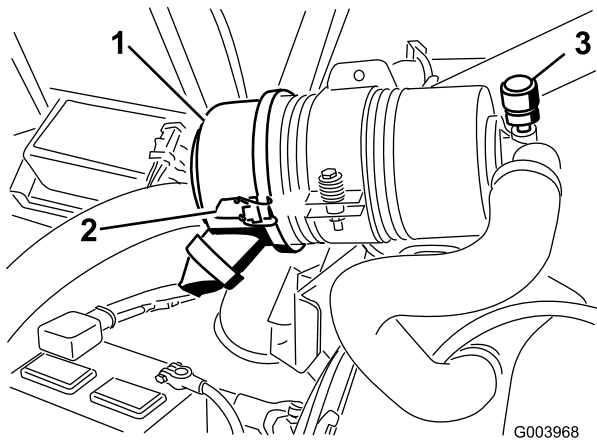

Figure 59

1. Air cleaner cover
2. Air cleaner cover latch
3. Air cleaner service indicator

2. Remove the cover from the air cleaner body. Before removing the filter, use low pressure air (40 psi, clean and dry) to help remove large accumulations of debris packed between outside of the filter and the canister. **Avoid using high pressure air which could force dirt through the filter into the intake tract.**

This cleaning process prevents debris from migrating into the intake when the filter is removed.

3. Remove and replace the filter (Figure 60).

Cleaning of the used element is not recommended due to the possibility of damage to the filter media. Inspect the new filter for shipping damage, checking the sealing end of the filter and the body. **Do not use a damaged element.** Insert the new filter by applying pressure to the outer rim of the element to seat it in the canister. **Do not apply pressure to the flexible center of the filter.**

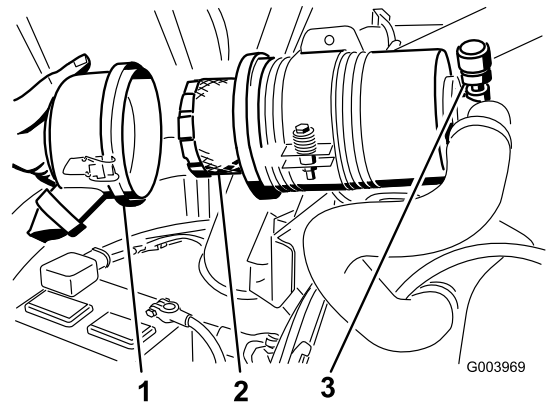

Figure 60

1. Air cleaner cover
2. Air cleaner filter
3. Air cleaner indicator

4. Clean the dirt ejection port located in the removable cover. Remove the rubber outlet valve from the cover, clean the cavity and replace the outlet valve.
5. Install the cover orienting the rubber outlet valve in a downward position—between approximately 5:00 to 7:00 when viewed from the end.
6. Secure the latches.

Servicing the Engine Oil and Filter

Change the engine oil and filter initially after the first 50 hours of operation and every 150 hours thereafter.

1. Remove the drain plug (Figure 61) and let the oil flow into a drain pan.

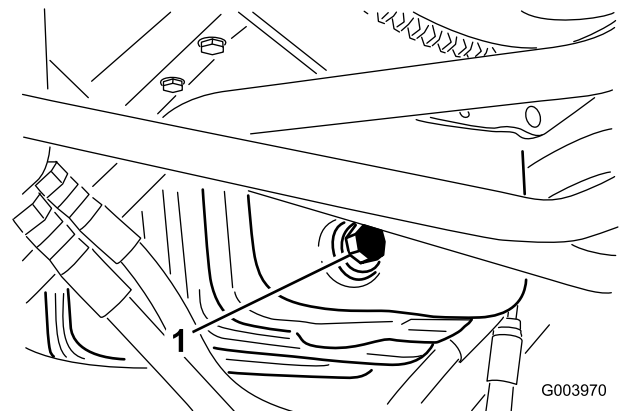

Figure 61

1. Oil drain plug

2. When the oil stops, install the drain plug.
3. Remove the oil filter (Figure 62).

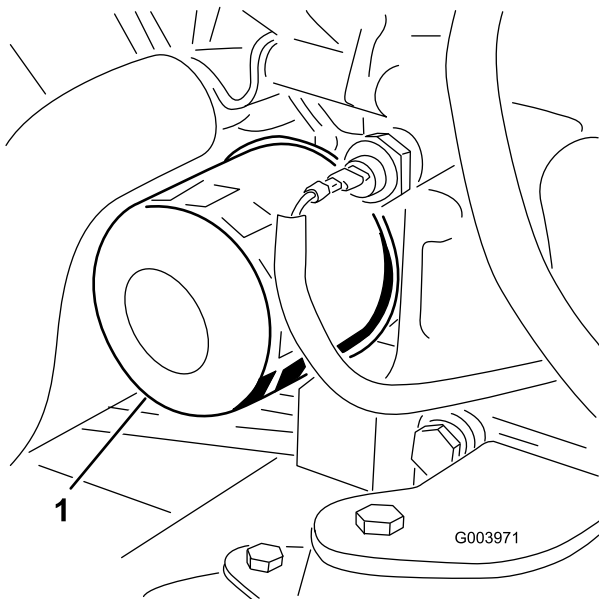

Figure 62

1. Oil filter

4. Apply a light coat of clean oil to the new filter seal.
5. Install the replacement oil filter to the filter adapter. Turn the oil filter clockwise until the rubber gasket contacts the filter adapter, then tighten the filter an additional 1/2 turn.

Important: Do not over-tighten the filter.

6. Add oil to the crankcase; refer to Checking the Engine Oil in , page .

Adjusting the Throttle

1. Position the throttle lever forward so it is approximately 1/8 inch from the front of the control arm slot.
2. Loosen the throttle cable connector, on the throttle cable, next to the injection pump lever (Figure 63).

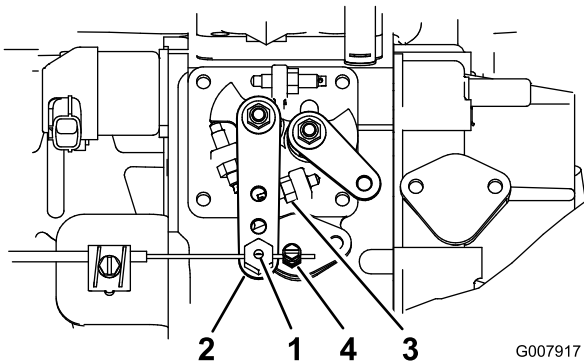

Figure 63

- | | |
|-----------------------------|-----------------------------|
| 1. Throttle cable pivot | 3. High idle stop |
| 2. Injection pump lever arm | 4. Throttle cable connector |

3. Hold the injection pump lever arm against the high idle stop (Figure 63).
 4. While pulling the throttle cable, to remove any slack, tighten the throttle cable connector.
- Note:** When tightened, the cable pivot must be free to swivel on the injection pump lever arm.
5. If the throttle does not stay in position during operation, increase the torque on the locknut, used to set the friction device on the throttle lever.

Fuel System Maintenance



Under certain conditions, diesel fuel and fuel vapors are highly flammable and explosive. A fire or explosion from fuel can burn you and others and can cause property damage.

- Use a funnel and fill the fuel tank outdoors, in an open area, when the engine is off and is cold. Wipe up any fuel that spills.
- Do not fill the fuel tank completely full. Add fuel to the fuel tank until the level is 1/4 to 1/2 in. (6 to 13 mm) below the bottom of the filler neck. This empty space in the tank allows the fuel to expand.
- Never smoke when handling fuel, and stay away from an open flame or where fuel fumes may be ignited by a spark.
- Store fuel in a clean, safety-approved container and keep the cap in place.

Draining the Fuel Tank

Service Interval: Every 800 hours
Before storage

Drain and clean the fuel tank if the fuel system becomes contaminated or if the machine is to be stored for an extended period. Use clean fuel to flush out the tank.

Checking the Fuel Lines and Connections

Check the fuel lines and connections every 400 hours or yearly, whichever comes first. Inspect them for deterioration, damage, or loose connections.

Servicing the Water Separator

Service Interval: Every 400 hours

Drain water or other contaminants from water separator (Figure 64) daily. Replace filter canister after every 400 hours of operation.

1. Place a clean container under the fuel filter.
2. Loosen the drain plug on the bottom of the filter canister.

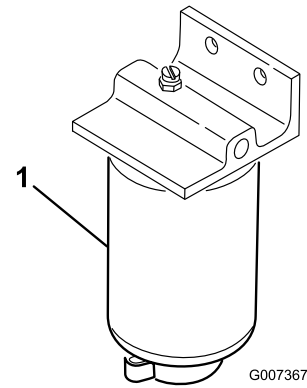

Figure 64

1. Water separator filter canister

3. Clean the area where the filter canister mounts.
4. Remove the filter canister and clean the mounting surface.
5. Lubricate the gasket on the filter canister with clean oil.
6. Install the filter canister by hand until the gasket contacts mounting surface, then rotate it an additional 1/2 turn.
7. Tighten the drain plug on the bottom of the filter canister.

Fuel Pick-up Tube Screen

The fuel pick-up tube, located inside the fuel tank, is equipped with a screen to help prevent debris from entering the fuel system. Remove the fuel pick-up tube and clean screen as required.

Bleeding Air from the Fuel Injectors

Note: This procedure should be used only if the fuel system has been purged of air through normal priming procedures and the engine will not start; refer to Bleeding the Fuel System in , page .

1. Loosen the pipe connection to the No. 1 nozzle and holder assembly (Figure 65).

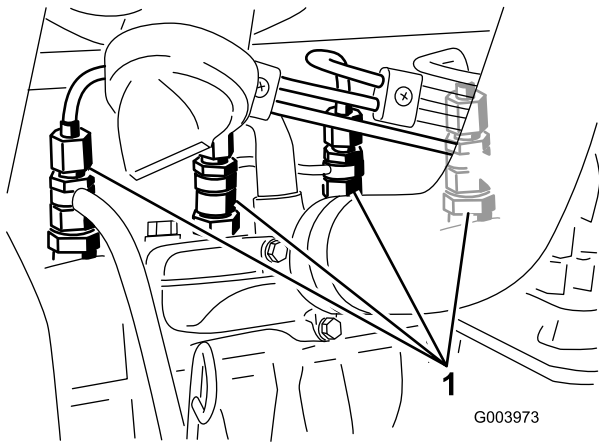

Figure 65

1. Fuel injectors

2. Turn the key in the key switch to the On position and watch the fuel flow around the connector. When you observe a solid flow of fuel, turn the key to the Off position.
3. Tighten the pipe connector securely.
4. Repeat steps 1 through 3 on the remaining nozzles.

Electrical System Maintenance

Important: Before welding on the machine, disconnect both cables from the battery, both wire harness plugs from the electronic control module, and the terminal connector from the alternator to prevent damage to the electrical system.

Servicing the Battery

Warning

CALIFORNIA

Proposition 65 Warning

Battery posts, terminals, and related accessories contain lead and lead compounds, chemicals known to the State of California to cause cancer and reproductive harm.
Wash hands after handling.



Battery electrolyte contains sulfuric acid which is a deadly poison and causes severe burns.

- Do not drink electrolyte and avoid contact with skin, eyes, or clothing. Wear safety glasses to shield your eyes and rubber gloves to protect your hands.
- Fill the battery where clean water is always available for flushing the skin.



Charging the battery produces gasses that can explode.

Never smoke near the battery and keep sparks and flames away from it.

Check the battery condition weekly or after every 50 hours of operation. Keep the terminals and the entire battery case clean because a dirty battery will discharge slowly. To clean the battery, wash the entire case with a solution of baking soda and water. Rinse it with clear water.

Fuses

There are 8 fuses in the electrical system. The fuse block (Figure 66) is located behind the control arm access panel.

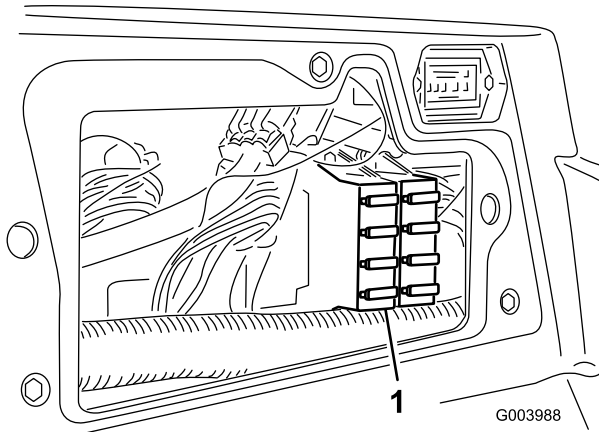

Figure 66

1. Fuse block

ACCESSORY FUSE BLOCK (OPTIONAL)	POWER POINT	ECM LOGIC POWER
	10A	2A
	HEADLIGHTS	ECM OUTPUT POWER C
	10A	10A
	MAIN POWER	ECM OUTPUT POWER B
	10A	10A
	STARTER	ECM OUTPUT POWER A
	15A	10A
110-0989		

Figure 67

Drive System Maintenance

Adjusting the Traction Drive for Neutral

The machine must not creep when the traction pedal is released. If it does creep, adjust as follows:

1. Park the machine on a level surface, stop the engine, and lower the cutting units to the floor.
2. Disconnect the left brake cable from the brake pedal (Figure 68) and set the parking brake.

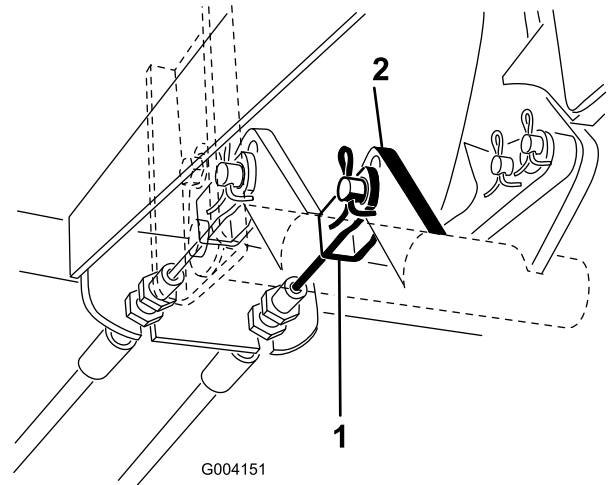

Figure 68

1. Left brake cable
 2. Brake pedal
3. Jack up the left side of the machine until the front tire is off the shop floor. Support the machine with jack stands to prevent it from falling accidentally.

Note: On 4 wheel drive models, the right rear tire must also be off the shop floor
 4. On the right side of the hydrostat, loosen the locknut on the traction adjustment cam (Figure 69).

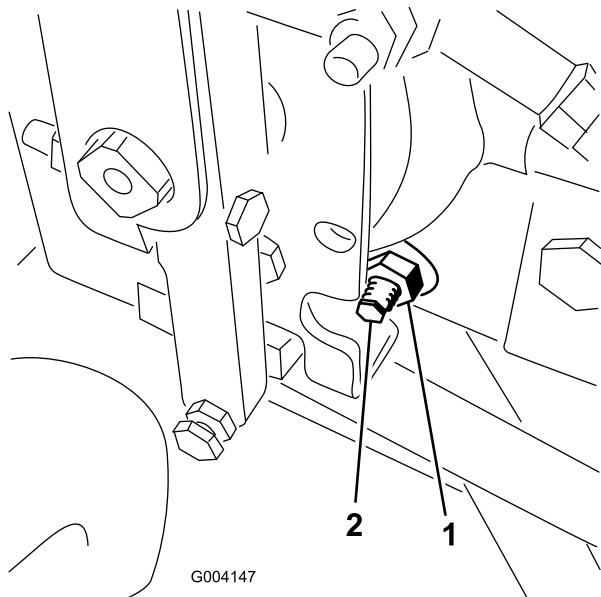

Figure 69

1. Locknut
2. Traction adjustment cam

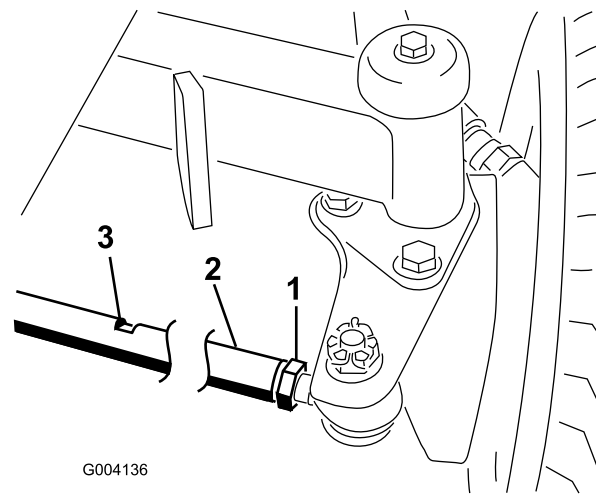

Figure 70

1. Jam nut
2. Tie rod
3. Wrench slot

3. Using the wrench slot, rotate the tie rod
4. Measure the distance at the front and rear of the rear wheels at axle height. The distance at the front of the rear wheels should be less than 1/4 inch (6 mm) of the distance measured at the rear of the wheels.
5. Repeat procedure as required.



The engine must be running so the final adjustment of the traction adjustment cam can be performed. This could cause personal injury.

Keep hands, feet, face, and other body parts away from the muffler, other hot parts of the engine, and any rotating parts.

5. Start the engine and rotate the cam hex in either direction until the wheel ceases rotation.
6. Tighten the locknut to secure the adjustment.
7. Stop the engine and release the parking brake. Remove the jack stands and lower the machine to the shop floor.
8. Re-attach the left brake cable to the brake pedal.
9. Test drive the machine to make sure it does not creep.

Adjusting the Rear Wheel Toe-in

1. Rotate the steering wheel so that the rear wheels are straight ahead.
2. Loosen the jam nut on each end of the tie rod (Figure 70).

Note: The end of the tie rod with the external groove is a left hand thread.

Cooling System Maintenance

Removing Debris from the Cooling System

Remove debris from the screen, oil coolers, and radiator daily (clean more frequently in dirty conditions).

1. Turn the engine off and remove the key from the ignition switch.
2. Thoroughly clean all debris out of the engine area.
3. Unlatch the clamp and pivot open the rear screen (Figure 71).

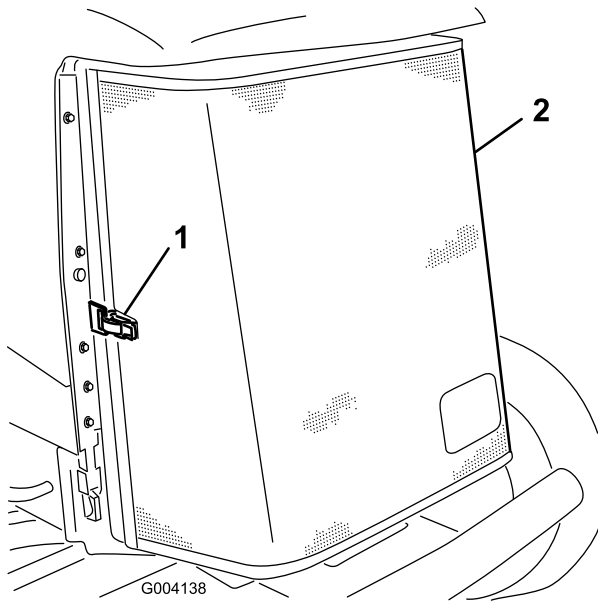

Figure 71

1. Rear screen latch
2. Rear screen

4. Clean the screen thoroughly with compressed air.
5. Pivot the latches inward to release the oil cooler (Figure 72).

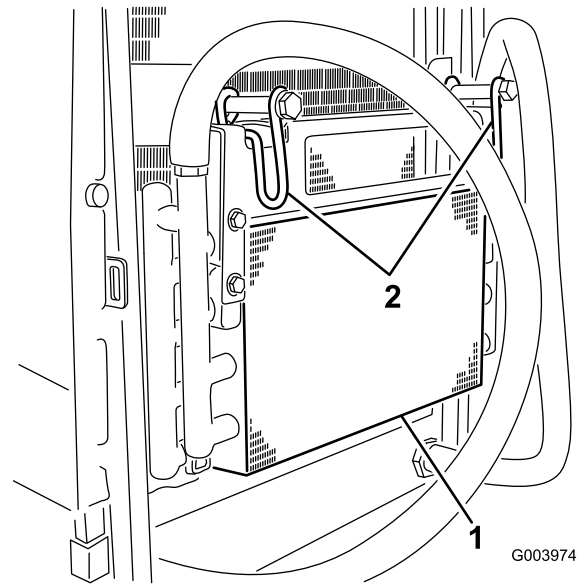

Figure 72

1. Oil cooler
2. Oil cooler latches

6. Thoroughly clean both sides of the oil cooler and the radiator (Figure 73) with compressed air.

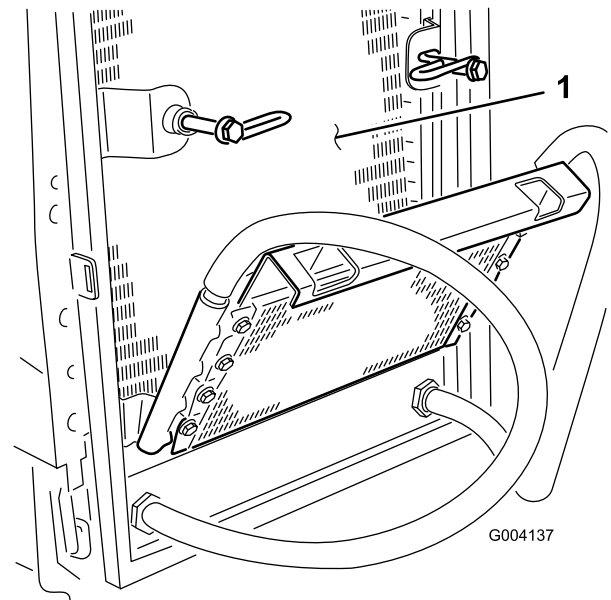

Figure 73

1. Radiator

7. Pivot the oil cooler back into position and secure the latches.
8. Close the screen and secure the latch.

Brake Maintenance

Adjusting the Service Brakes

Adjust the service brakes when there is more than 1 inch of free travel of the brake pedal, or when the brakes do not work effectively. Free travel is the distance the brake pedal moves before you feel braking resistance.

1. To reduce free travel of the brake pedals, tighten the brakes by loosening the front nut on the threaded end of the brake cable (Figure 74).

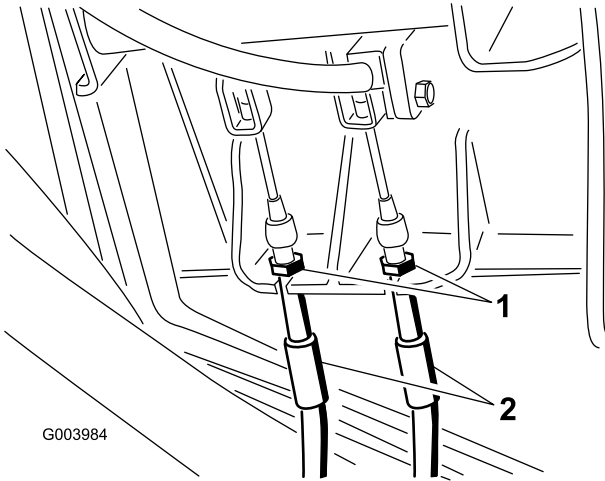

Figure 74

1. Front nuts
2. Brake cables

2. Tighten the rear nut to move the cable backward until brake pedals have 1/4 to 1/2 inch (.63 to 1.27cm) of free travel.
3. Tighten the front nuts, ensuring that both cables actuate the brakes simultaneously.
4. To increase brake pedal travel, move the brake cables to the upper set of holes in the brake pedal mechanism. Check adjustment and repeat procedure if additional adjustment is required.

Adjusting the Parking Brake

If the parking brake fails to engage, an adjustment to the brake pawl is required.

1. Remove the cotter pins and clevis pins securing the brake cables to the brake pedal rod (Figure 75).

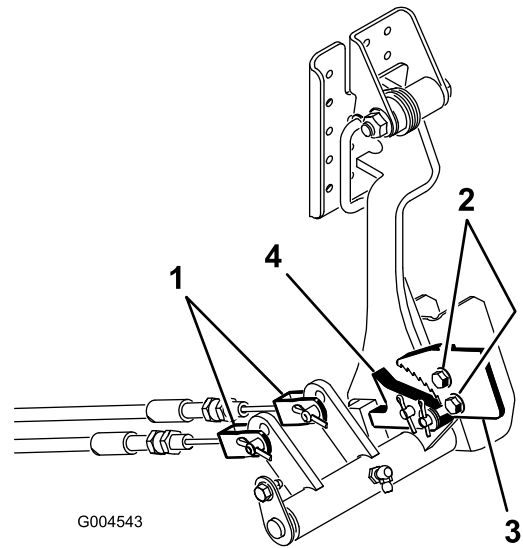

Figure 75

1. Brake cables
2. Screws (2)
3. Parking brake pawl
4. Brake detent

2. Loosen the 2 screws securing the parking brake pawl to the frame (Figure 75).
3. Press the parking brake pedal forward until the brake detent completely engages on the brake pawl (Figure 75).
4. Tighten the 2 screws locking the adjustment.
5. Press the brake pedal to release the parking brake.
6. Check the adjustment and re-adjust as required.
7. Secure the brake cables to the brake pedal with the cotter pins and clevis pins removed.

Belt Maintenance

Check the condition and tension of the alternator belt after the first day of operation and every 100 operating hours thereafter.

Tensioning the Alternator Belt

1. Open the hood.
2. Check the tension of the alternator belt by depressing it (Figure 76) midway between the alternator and the crankshaft pulleys with 22 lb (10 kg) of force.

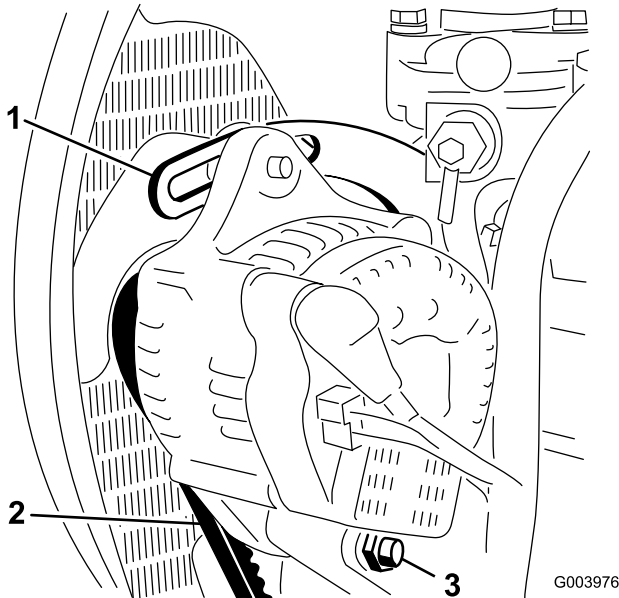

Figure 76

1. Brace
2. Alternator belt
3. Pivot bolt

The belt should deflect 7/16 inch (11 mm). If the deflection is incorrect, proceed to step 3. If correct, continue operation.

3. Loosen the bolt securing the brace to the engine (Figure 76), the bolt securing the alternator to the brace and the pivot bolt.
4. Insert a pry bar between the alternator and the engine and pry out on the alternator.
5. When you achieve the proper tension, tighten the alternator, brace and pivot bolts to secure the adjustment.

Hydraulic System Maintenance

Changing the Hydraulic Fluid

Change hydraulic fluid after every 800 operating hours, in normal conditions. If fluid becomes contaminated, contact your local Toro distributor because the system must be flushed. Contaminated fluid looks milky or black when compared to clean oil.

1. Stop the engine and raise the hood.
2. Place a large drain pan under the fitting secured to the bottom of the hydraulic fluid reservoir (Figure 77).

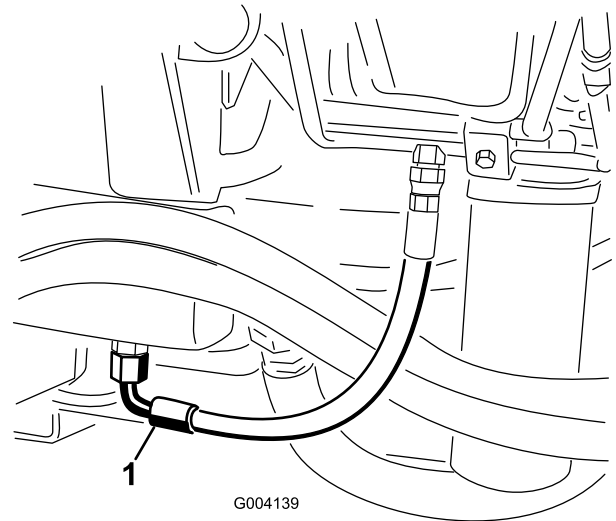

Figure 77

1. Hose

3. Disconnect the hose from the bottom of the fitting and let the hydraulic fluid flow into the drain pan.
4. Install the hose when hydraulic fluid stops draining.
5. Fill the reservoir with approximately 8 U.S. gallons (30 l) of hydraulic fluid; refer to Checking the Hydraulic Fluid in , page .

Important: Use only hydraulic fluids specified. Other fluids could cause system damage.

6. Install the reservoir cap.
7. Start the engine and use all of the hydraulic controls to distribute hydraulic fluid throughout the system. Also check for leaks.
8. Stop the engine.
9. Check the level of the hydraulic fluid and add enough to raise level to the Full mark on the dipstick.

Important: Do not over-fill.

Replacing the Hydraulic Filters

The hydraulic system is equipped with a service interval indicator (Figure 78). With the engine running, view the indicator, it should be in the Green zone. When the indicator is in the Red zone, change the hydraulic filters.

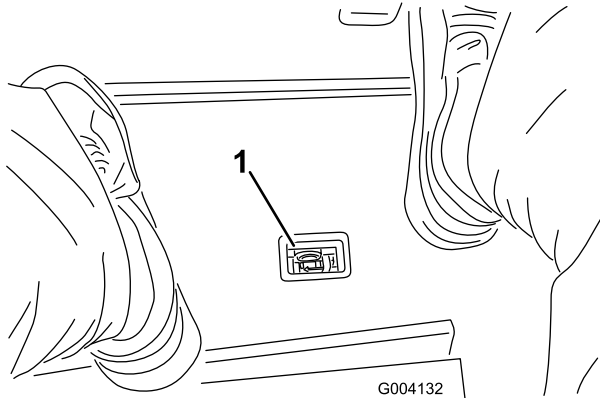

Figure 78

1. Hydraulic filter restriction indicator

Important: Use of any other filters may void the warranty on some components.

1. Position the machine on a level surface, lower the cutting units, stop the engine, engage the parking brake, and remove the key from the ignition switch.
2. Clean the area around the filter mounting area and place a drain pan under filter (Figure 79) and (Figure 80).

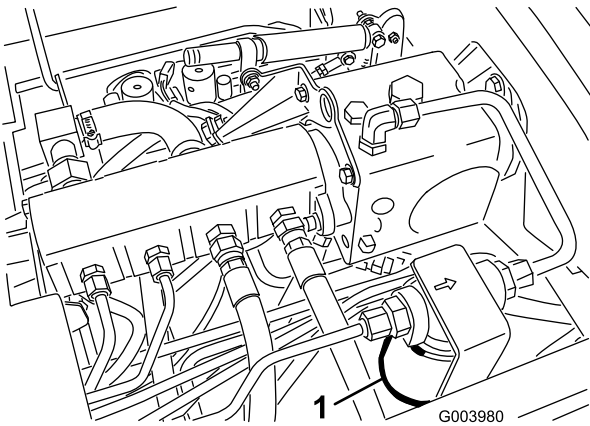

Figure 79

1. Hydraulic filter

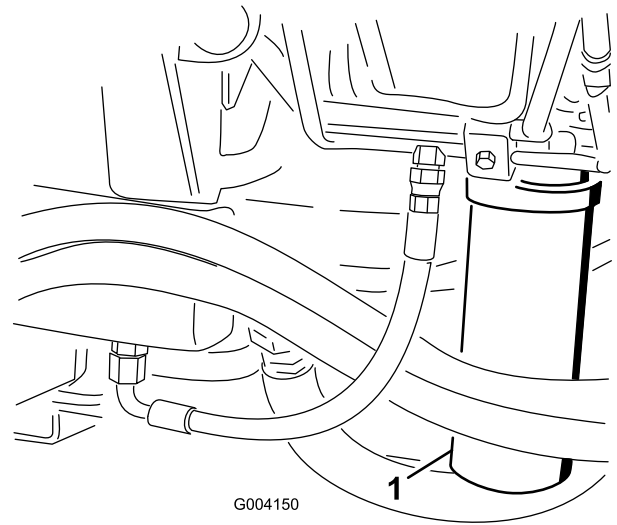

Figure 80

1. Hydraulic filter
3. Remove the filter.
4. Lubricate the gasket on the new filter with hydraulic oil.
5. Ensure that the filter mounting area is clean.
6. Install the filter by hand until the gasket contacts the mounting surface, then rotate it an additional 1/2 turn.
7. Repeat the procedure on the other filter.
8. Start the engine and let it run for about two minutes to purge air from the system.
9. Stop the engine and check for leaks.

Checking the Hydraulic Lines and Hoses

Daily, check hydraulic lines and hoses for leaks, kinked lines, loose mounting supports, wear, loose fittings, weather deterioration, and chemical deterioration. Make all necessary repairs before operating.



Hydraulic fluid escaping under pressure can penetrate skin and cause injury.

- Make sure all hydraulic fluid hoses and lines are in good condition and all hydraulic connections and fittings are tight before applying pressure to the hydraulic system.
- Keep your body and hands away from pin hole leaks or nozzles that eject high pressure hydraulic fluid.
- Use cardboard or paper to find hydraulic leaks.
- Safely relieve all pressure in the hydraulic system before performing any work on the hydraulic system.
- Get immediate medical help if fluid is injected into skin.

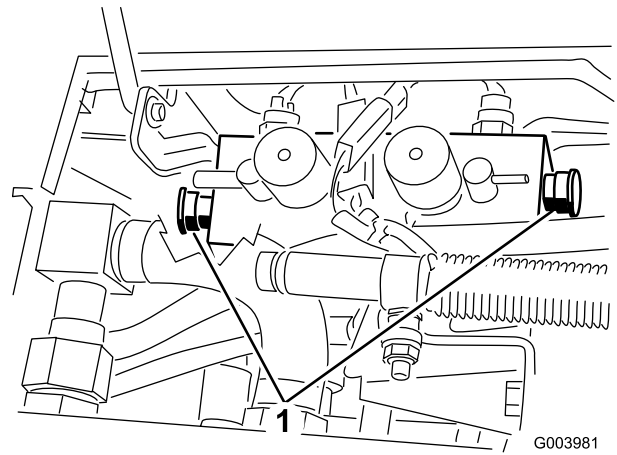

Figure 82

1. Mow circuit test ports (2)

Use the test port on the lift manifold block (Figure 83) to assist in troubleshooting the lift circuit.

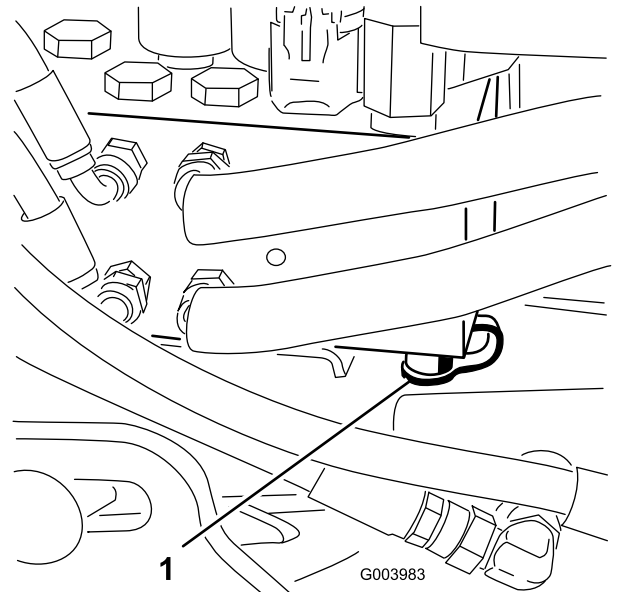

Figure 83

1. Lift circuit test port

Hydraulic System Test Ports

Use the hydraulic system test ports to test the pressure in the hydraulic circuits. Contact your local Toro distributor for assistance.

Use the test ports on the front hydraulic tubes (Figure 81) to assist in troubleshooting the traction circuit.

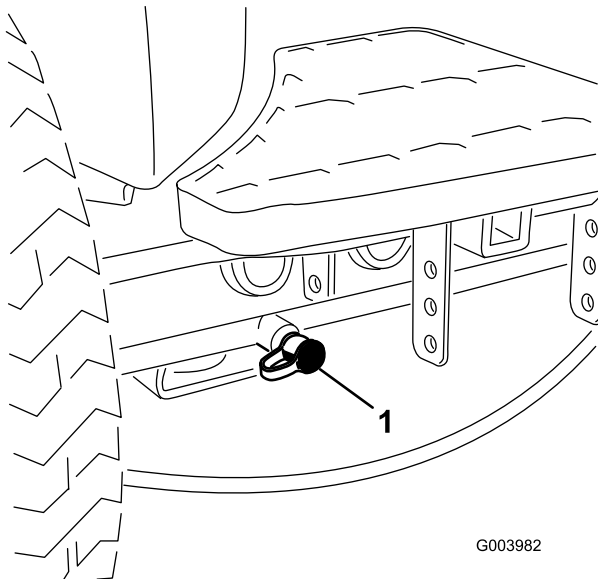

Figure 81

1. Traction circuit test port

Use the test ports on the mow manifold block (Figure 82) to assist in troubleshooting the mow circuit.

Cutting Unit System Maintenance

Backlapping the Cutting Units



Contact with the reels or other moving parts can result in personal injury.

- Keep fingers, hands, and clothing away from the reels or other moving parts.
- Never attempt to turn the reels by hand or foot while the engine is running.

Note: When backlapping, the front units all operate together, and the rear units operate together.

1. Position the machine on a level surface, lower the cutting units, stop the engine, engage the parking brake, and move the Enable/Disable switch to disable position.
2. Unlock and raise the seat to expose the controls.
3. Make initial reel to bedknife adjustments appropriate for backlapping on all cutting units which are to be backlapped; refer to the cutting unit *Operator's Manual*.
4. Start the engine and run at low idle speed.



Changing the engine speed while backlapping may cause the reels to stall.

- Never change the engine speed while backlapping.
- Only backlap at idle engine speed.

5. Set both reel speed controls to position 1 (Figure 84).

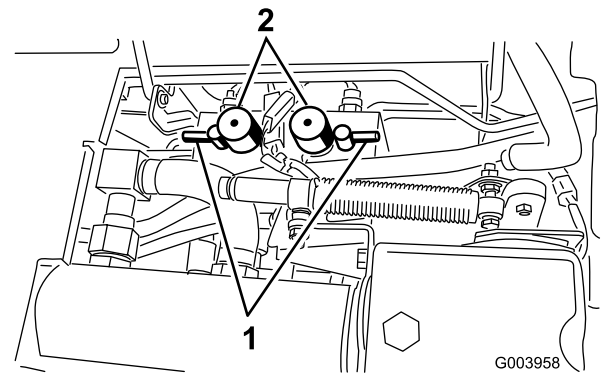

Figure 84

1. Backlap levers
2. Reel speed control knobs

6. Select either front, rear or both backlap levers to determine which units to backlap (Figure 84).



To avoid personal injury, be certain that you are clear of the cutting units before proceeding.

7. With the Mow/Transport lever in the mow position, move the Enable/Disable switch to the Enable position. Move the Lower Mow/Lift control forward to start the backlapping operation on the designated reels.
8. Apply lapping compound with a long handle brush. Never use a short handled brush.
9. If the reels stall or become erratic while backlapping, select a higher reel speed setting until the speed stabilizes, then return the reel speed to setting 1 or to your desired speed.
10. To make an adjustment to the cutting units while backlapping, turn the reels off by moving the Lower Mow/Raise lever rearward; the Enable/Disable switch to the Disable position, and stop the engine. After completing adjustments, repeat steps 5 through 9.
11. Repeat the procedure for all cutting units you want to backlap.
12. When finished, return the backlap levers to the Mow position, lower the seat, and wash all lapping compound off of the cutting units. Adjust cutting unit reel to bedknife as needed. Move the cutting unit reel speed controls to the desired mowing position.

Important: If the backlap switch is not returned to the Off position after backlapping, the cutting units will not raise or function properly.

Storage

Preparing the Traction Unit

1. Thoroughly clean the traction unit, cutting units, and engine.
2. Check the tire pressure. Inflate all traction unit tires to 12 to 15 psi (83 to 103 kPa).
3. Check all fasteners for looseness and tighten them as necessary.
4. Grease all grease fittings and pivot points. Wipe up any excess lubricant.
5. Lightly sand and use touch-up paint on painted areas that are scratched, chipped, or rusted. Repair any dents in the metal body.
6. Service the battery and cables as follows:
 - A. Remove the battery terminals from the battery posts.
 - B. Clean the battery, terminals, and posts with a wire brush and baking soda solution.
 - C. Coat the cable terminals and battery posts with Grafo 112X skin-over grease (Toro Part No. 505-47) or petroleum jelly to prevent corrosion.
 - D. Slowly recharge the battery every 60 days for 24 hours to prevent lead sulfation of the battery.

Preparing the Engine

1. Drain the engine oil from the oil pan and replace the drain plug.
2. Remove and discard the oil filter. Install a new oil filter.
3. Refill the oil pan with designated quantity of motor oil.
4. Start the engine and run it at idle speed for approximately two minutes.
5. Stop the engine.
6. Thoroughly drain all fuel from the fuel tank, lines, and the fuel filter/water separator assembly.
7. Flush the fuel tank with fresh, clean diesel fuel.
8. Secure all fuel system fittings.
9. Thoroughly clean and service the air cleaner assembly.
10. Seal the air cleaner inlet and the exhaust outlet with weatherproof tape.
11. Check the antifreeze protection and add as needed for expected minimum temperature in your area.

Schematics

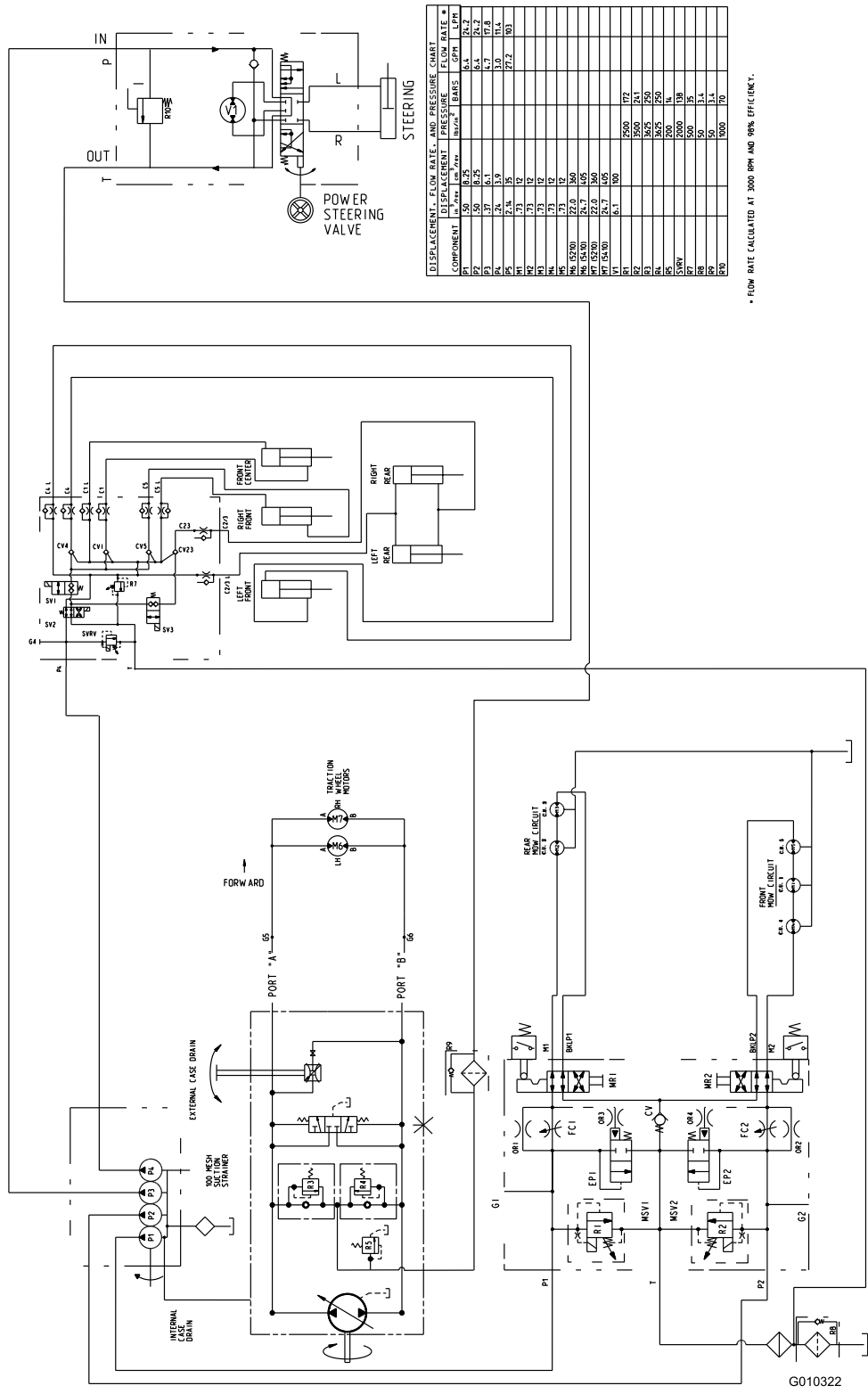

* FLOW RATE CALCULATED AT 3000 RPM AND 98% EFFICIENCY.

Hydraulic Schematic, Model 5210 & 5410 (Rev. A)

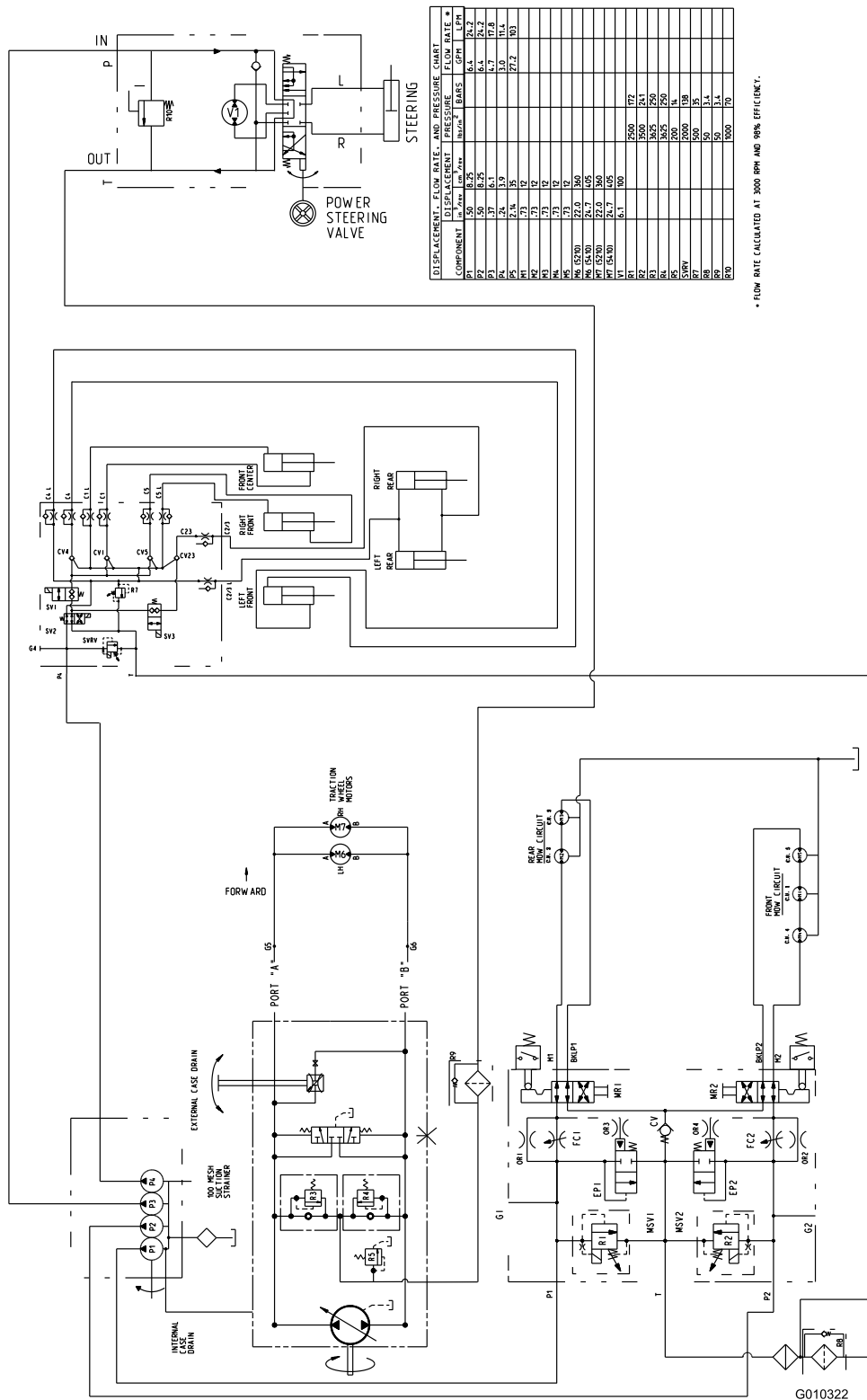

COMPONENT	DISPLACEMENT		FLOW RATE		PRESSURE		FLOW RATE	
	in ³ /rev	cm ³ /rev	in ³ /min	cm ³ /min	PSI	BAR	gpm	lpm
P1	1.50	8.35	15.0	83.5	1500	103.4	1500	103.4
P2	1.50	8.35	15.0	83.5	1500	103.4	1500	103.4
P3	1.37	8.1	13.7	81.0	1500	103.4	13.7	81.0
P4	1.37	8.1	13.7	81.0	1500	103.4	13.7	81.0
P5	1.37	8.1	13.7	81.0	1500	103.4	13.7	81.0
P6	1.37	8.1	13.7	81.0	1500	103.4	13.7	81.0
P7	1.37	8.1	13.7	81.0	1500	103.4	13.7	81.0
P8	1.37	8.1	13.7	81.0	1500	103.4	13.7	81.0
P9	1.37	8.1	13.7	81.0	1500	103.4	13.7	81.0
P10	1.37	8.1	13.7	81.0	1500	103.4	13.7	81.0
P11	1.37	8.1	13.7	81.0	1500	103.4	13.7	81.0
P12	1.37	8.1	13.7	81.0	1500	103.4	13.7	81.0
P13	1.37	8.1	13.7	81.0	1500	103.4	13.7	81.0
P14	1.37	8.1	13.7	81.0	1500	103.4	13.7	81.0
P15	1.37	8.1	13.7	81.0	1500	103.4	13.7	81.0
P16	1.37	8.1	13.7	81.0	1500	103.4	13.7	81.0
P17	1.37	8.1	13.7	81.0	1500	103.4	13.7	81.0
P18	1.37	8.1	13.7	81.0	1500	103.4	13.7	81.0
P19	1.37	8.1	13.7	81.0	1500	103.4	13.7	81.0
P20	1.37	8.1	13.7	81.0	1500	103.4	13.7	81.0
P21	1.37	8.1	13.7	81.0	1500	103.4	13.7	81.0
P22	1.37	8.1	13.7	81.0	1500	103.4	13.7	81.0
P23	1.37	8.1	13.7	81.0	1500	103.4	13.7	81.0
P24	1.37	8.1	13.7	81.0	1500	103.4	13.7	81.0
P25	1.37	8.1	13.7	81.0	1500	103.4	13.7	81.0
P26	1.37	8.1	13.7	81.0	1500	103.4	13.7	81.0
P27	1.37	8.1	13.7	81.0	1500	103.4	13.7	81.0
P28	1.37	8.1	13.7	81.0	1500	103.4	13.7	81.0
P29	1.37	8.1	13.7	81.0	1500	103.4	13.7	81.0
P30	1.37	8.1	13.7	81.0	1500	103.4	13.7	81.0
P31	1.37	8.1	13.7	81.0	1500	103.4	13.7	81.0
P32	1.37	8.1	13.7	81.0	1500	103.4	13.7	81.0
P33	1.37	8.1	13.7	81.0	1500	103.4	13.7	81.0
P34	1.37	8.1	13.7	81.0	1500	103.4	13.7	81.0
P35	1.37	8.1	13.7	81.0	1500	103.4	13.7	81.0
P36	1.37	8.1	13.7	81.0	1500	103.4	13.7	81.0
P37	1.37	8.1	13.7	81.0	1500	103.4	13.7	81.0
P38	1.37	8.1	13.7	81.0	1500	103.4	13.7	81.0
P39	1.37	8.1	13.7	81.0	1500	103.4	13.7	81.0
P40	1.37	8.1	13.7	81.0	1500	103.4	13.7	81.0
P41	1.37	8.1	13.7	81.0	1500	103.4	13.7	81.0
P42	1.37	8.1	13.7	81.0	1500	103.4	13.7	81.0
P43	1.37	8.1	13.7	81.0	1500	103.4	13.7	81.0
P44	1.37	8.1	13.7	81.0	1500	103.4	13.7	81.0
P45	1.37	8.1	13.7	81.0	1500	103.4	13.7	81.0
P46	1.37	8.1	13.7	81.0	1500	103.4	13.7	81.0
P47	1.37	8.1	13.7	81.0	1500	103.4	13.7	81.0
P48	1.37	8.1	13.7	81.0	1500	103.4	13.7	81.0
P49	1.37	8.1	13.7	81.0	1500	103.4	13.7	81.0
P50	1.37	8.1	13.7	81.0	1500	103.4	13.7	81.0
P51	1.37	8.1	13.7	81.0	1500	103.4	13.7	81.0
P52	1.37	8.1	13.7	81.0	1500	103.4	13.7	81.0
P53	1.37	8.1	13.7	81.0	1500	103.4	13.7	81.0
P54	1.37	8.1	13.7	81.0	1500	103.4	13.7	81.0
P55	1.37	8.1	13.7	81.0	1500	103.4	13.7	81.0
P56	1.37	8.1	13.7	81.0	1500	103.4	13.7	81.0
P57	1.37	8.1	13.7	81.0	1500	103.4	13.7	81.0
P58	1.37	8.1	13.7	81.0	1500	103.4	13.7	81.0
P59	1.37	8.1	13.7	81.0	1500	103.4	13.7	81.0
P60	1.37	8.1	13.7	81.0	1500	103.4	13.7	81.0
P61	1.37	8.1	13.7	81.0	1500	103.4	13.7	81.0
P62	1.37	8.1	13.7	81.0	1500	103.4	13.7	81.0
P63	1.37	8.1	13.7	81.0	1500	103.4	13.7	81.0
P64	1.37	8.1	13.7	81.0	1500	103.4	13.7	81.0
P65	1.37	8.1	13.7	81.0	1500	103.4	13.7	81.0
P66	1.37	8.1	13.7	81.0	1500	103.4	13.7	81.0
P67	1.37	8.1	13.7	81.0	1500	103.4	13.7	81.0
P68	1.37	8.1	13.7	81.0	1500	103.4	13.7	81.0
P69	1.37	8.1	13.7	81.0	1500	103.4	13.7	81.0
P70	1.37	8.1	13.7	81.0	1500	103.4	13.7	81.0
P71	1.37	8.1	13.7	81.0	1500	103.4	13.7	81.0
P72	1.37	8.1	13.7	81.0	1500	103.4	13.7	81.0
P73	1.37	8.1	13.7	81.0	1500	103.4	13.7	81.0
P74	1.37	8.1	13.7	81.0	1500	103.4	13.7	81.0
P75	1.37	8.1	13.7	81.0	1500	103.4	13.7	81.0

* FLOW RATE CALCULATED AT 3000 RPM AND 98% EFFICIENCY.

Hydraulic Schematic, Model 5510 & 5610 (Rev. A)

G010322

Notes:



Toro General Commercial Products Warranty

A Two-Year Limited Warranty

Conditions and Products Covered

The Toro Company and its affiliate, Toro Warranty Company, pursuant to an agreement between them, jointly warrant your Toro Commercial Product ("Product") to be free from defects in materials or workmanship for two years or 1500 operational hours*, whichever occurs first. This warranty is applicable to all products with the exception of Aerators (refer to separate warranty statements for these products). Where a warrantable condition exists, we will repair the Product at no cost to you including diagnosis, labor, parts, and transportation. This warranty begins on the date the Product is delivered to the original retail purchaser.

* Product equipped with hour meter

Instructions for Obtaining Warranty Service

You are responsible for notifying the Commercial Products Distributor or Authorized Commercial Products Dealer from whom you purchased the Product as soon as you believe a warrantable condition exists. If you need help locating a Commercial Products Distributor or Authorized Dealer, or if you have questions regarding your warranty rights or responsibilities, you may contact us at:

Toro Commercial Products Service Department
Toro Warranty Company
8111 Lyndale Avenue South
Bloomington, MN 55420-1196
952-888-8801
E-mail: commercial.warranty@toro.com

Owner Responsibilities

As the Product owner, you are responsible for required maintenance and adjustments stated in your *Operator's Manual*. Failure to perform required maintenance and adjustments can be grounds for disallowing a warranty claim.

Items and Conditions Not Covered

Not all product failures or malfunctions that occur during the warranty period are defects in materials or workmanship. This warranty does not cover the following:

- Product failures which result from the use of non-Toro replacement parts, or from installation and use of add-on, or modified non-Toro branded accessories and products. A separate warranty may be provided by the manufacturer of these items.
- Product failures which result from failure to perform recommended maintenance and/or adjustments. Failure to properly maintain your Toro product per the Recommended Maintenance listed in the *Operator's Manual* can result in claims for warranty being denied.
- Product failures which result from operating the Product in an abusive, negligent or reckless manner.
- Parts subject to consumption through use unless found to be defective. Examples of parts which are consumed, or used up, during normal Product operation include, but are not limited to, brakes pads and linings, clutch linings, blades, reels, bed knives, tines, spark plugs, castor wheels, tires, filters, belts, and certain sprayer components such as diaphragms, nozzles, and check valves, etc.
- Failures caused by outside influence. Items considered to be outside influence include, but are not limited to, weather, storage practices, contamination, use of unapproved coolants,

lubricants, additives, fertilizers, water, or chemicals, etc.

- Normal noise, vibration, wear and tear, and deterioration.
- Normal "wear and tear" includes, but is not limited to, damage to seats due to wear or abrasion, worn painted surfaces, scratched decals or windows, etc.

Parts

Parts scheduled for replacement as required maintenance are warranted for the period of time up to the scheduled replacement time for that part. Parts replaced under this warranty are covered for the duration of the original product warranty and become the property of Toro. Toro will make the final decision whether to repair any existing part or assembly or replace it. Toro may use remanufactured parts for warranty repairs.

Note Regarding Deep Cycle Battery Warranty:

Deep cycle batteries have a specified total number of kilowatt-hours they can deliver during their lifetime. Operating, recharging, and maintenance techniques can extend or reduce total battery life. As the batteries in this product are consumed, the amount of useful work between charging intervals will slowly decrease until the battery is completely worn out. Replacement of worn out batteries, due to normal consumption, is the responsibility of the product owner. Battery replacement may be required during the normal product warranty period at owner's expense.

Maintenance is at Owner's Expense

Engine tune-up, lubrication cleaning and polishing, replacement of filters, coolant, and completing Recommended Maintenance are some of the normal services Toro products require that are at the owner's expense.

General Conditions

Repair by an Authorized Toro Distributor or Dealer is your sole remedy under this warranty.

Neither The Toro Company nor Toro Warranty Company is liable for indirect, incidental or consequential damages in connection with the use of the Toro Products covered by this warranty, including any cost or expense of providing substitute equipment or service during reasonable periods of malfunction or non-use pending completion of repairs under this warranty. Except for the Emissions warranty referenced below, if applicable, there is no other express warranty. All implied warranties of merchantability and fitness for use are limited to the duration of this express warranty.

Some states do not allow exclusions of incidental or consequential damages, or limitations on how long an implied warranty lasts, so the above exclusions and limitations may not apply to you. This warranty gives you specific legal rights, and you may also have other rights which vary from state to state.

Note regarding engine warranty:

The Emissions Control System on your Product may be covered by a separate warranty meeting requirements established by the U.S. Environmental Protection Agency (EPA) and/or the California Air Resources Board (CARB). The hour limitations set forth above do not apply to the Emissions Control System Warranty. Refer to the Engine Emission Control Warranty Statement printed in your *Operator's Manual* or contained in the engine manufacturer's documentation for details.

Countries Other than the United States or Canada

Customers who have purchased Toro products exported from the United States or Canada should contact their Toro Distributor (Dealer) to obtain guarantee policies for your country, province, or state. If for any reason you are dissatisfied with your Distributor's service or have difficulty obtaining guarantee information, contact the Toro importer.