



**Count on it.**

**Operator's Manual**

**Groundsmaster® 3500-D**

**Groundsmaster Traction Unit**

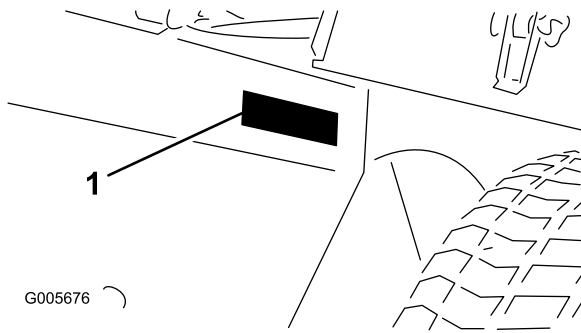
**Model No. 30839—Serial No. 28000001 and Up**

# Introduction

Read this information carefully to learn how to operate and maintain your product properly and to avoid injury and product damage. You are responsible for operating the product properly and safely.

You may contact Toro directly at [www.Toro.com](http://www.Toro.com) for product and accessory information, help finding a dealer, or to register your product.

Whenever you need service, genuine Toro parts, or additional information, contact an Authorized Service Dealer or Toro Customer Service and have the model and serial numbers of your product ready. Figure 1 identifies the location of the model and serial numbers on the product. Write the numbers in the space provided.



**Figure 1**

1. Model and serial number location

<b>Model No.</b> _____
<b>Serial No.</b> _____

This manual identifies potential hazards and has safety messages identified by the safety alert symbol (Figure 2), which signals a hazard that may cause serious injury or death if you do not follow the recommended precautions.



**Figure 2**

1. Safety alert symbol

This manual uses 2 other words to highlight information. **Important** calls attention to special mechanical information and **Note** emphasizes general information worthy of special attention.

## Warning

### CALIFORNIA

#### Proposition 65 Warning

**Diesel engine exhaust and some of its constituents are known to the State of California to cause cancer, birth defects, and other reproductive harm.**

# Contents

Introduction.....	2
Safety .....	3
Safe Operating Practices .....	3
Toro Mower Safety .....	5
Sound Power Level.....	7
Sound Pressure Level .....	7
Vibration Level.....	7
Safety and Instructional Decals .....	7
Setup.....	12
1 Activating, Charging, and Connecting the Battery .....	12
2 Checking the Angle Indicator .....	14
3 Installing the Hood Latch (CE Only) .....	14
4 Installing the Exhaust Guard (CE Only).....	15
5 Adjusting the Lift Arms .....	15
6 Rear Ballast.....	17
Product Overview .....	17
Controls .....	17
Specifications .....	19
Attachments/Accessories.....	19
Operation.....	20
Checking the Engine Oil Level.....	20
Filling the Fuel Tank.....	20
Checking the Cooling System.....	21
Checking the Hydraulic System.....	22
Checking the Tire Pressure .....	23
Torquing the Wheel Nuts.....	23
Starting and Stopping the Engine .....	23
Bleeding the Fuel System .....	23
Checking the Interlock System.....	24
Towing the Traction Unit.....	24
Standard Control Module (SCM) .....	25
Operating Tips .....	27
Maintenance.....	29
Recommended Maintenance Schedule(s) .....	29
Daily Maintenance Checklist.....	30
Service Interval Chart.....	31
Premaintenance Procedures.....	31
Removing the Hood .....	31
Lubrication.....	32

Greasing the Bearings And Bushings.....	32
Engine Maintenance.....	35
Servicing the Air Cleaner .....	35
Changing the Engine Oil and Filter .....	35
Fuel System Maintenance .....	36
Servicing the Fuel Tank .....	36
Inspecting the Fuel Lines and Connections.....	36
Draining the Water Separator.....	36
Changing the Fuel Filter Canister .....	36
Bleeding Air from the Injectors.....	37
Electrical System Maintenance.....	37
Caring for the Battery .....	37
Fuses.....	38
Drive System Maintenance .....	38
Adjusting the Traction Drive for Neutral .....	38
Cooling System Maintenance.....	39
Cleaning the Engine Cooling System.....	39
Brake Maintenance.....	39
Adjusting the Parking Brake.....	39
Belt Maintenance.....	40
Servicing the Engine Belts .....	40
Controls System Maintenance.....	41
Adjusting the Throttle .....	41
Hydraulic System Maintenance .....	41
Changing the Hydraulic Filter .....	41
Changing the Hydraulic Fluid .....	41
Checking the Hydraulic Lines and Hoses .....	42
Storage.....	43
Storing the Battery.....	43
Preparation for Seasonal Storage.....	43
Schematics .....	44

# Safety

**This machine meets or exceeds CEN standard EN 836:1997 (when appropriate decals applied), and ANSI B71.4-2004 specifications in effect at the time of production when equipped with required weights as listed in the weight chart.**

**Improper use or maintenance by the operator or owner can result in injury. To reduce the potential for injury, comply with these safety instructions and always pay attention to the safety alert symbol, which means Caution, Warning, or Danger—personal safety instruction. Failure to comply with the instruction may result in personal injury or death.**

## Safe Operating Practices

The following instructions are from the CEN standard EN 836:1997, ISO standard 5395:1990, and ANSI B71.4-2004.

## Training

- Read the *Operator's Manual* and other training material carefully. Be familiar with the controls, safety signs, and the proper use of the equipment.
- If the operator or mechanic can not read the language of this manual, it is the owner's responsibility to explain this material to them.
- Never allow children or people unfamiliar with these instructions to use or service the mower. Local regulations may restrict the age of the operator.
- Never mow while people, especially children, or pets are nearby.
- Keep in mind that the operator or user is responsible for accidents or hazards occurring to other people or their property.
- Do not carry passengers.
- All drivers and mechanics should seek and obtain professional and practical instruction. The owner is responsible for training the users. Such instruction should emphasize the following:
  - The need for care and concentration when working with ride-on machines
  - Control of a ride-on machine sliding on a slope will not be regained by the application of the brake. The main reasons for loss of control are as follows:
    - ◇ Insufficient wheel grip
    - ◇ Being driven too fast

- ◇ Inadequate braking
- ◇ The type of machine is unsuitable for the task
- ◇ Lack of awareness of the effect of ground conditions, especially slopes
- ◇ Incorrect hitching and load distribution

## Preparation

- While mowing, always wear substantial footwear, long trousers, hard hat, safety glasses, and hearing protection. Long hair, loose clothing, or jewelry may get tangled in moving parts. Do not operate the equipment when barefoot or wearing open sandals.
- Thoroughly inspect the area where the equipment is to be used and remove all objects which may be thrown by the machine.
- **Warning**—Fuel is highly flammable. Take the following precautions:
  - Store fuel in containers specifically designed for this purpose.
  - Refuel outdoors only and do not smoke while refueling.
  - Add fuel before starting the engine. Never remove the cap of the fuel tank or add fuel while the engine is running or when the engine is hot.
  - If fuel is spilled, do not attempt to start the engine but move the machine away from the area of spillage and avoid creating any source of ignition until fuel vapors have dissipated.
  - Replace all fuel tank and container caps securely.
- Replace faulty silencers/mufflers.
- Before using, always visually inspect to see that the blades, blade bolts, and cutting assembly are not worn or damaged. Replace worn or damaged blades and bolts in sets to preserve balance.
- On multi-bladed machines, take care as rotating one blade can cause other blades to rotate.
- Evaluate the terrain to determine what accessories and attachments are needed to properly and safely perform the job. Only use accessories and attachments approved by the manufacturer.
- Check that operator's presence controls, safety switches and shields are attached and functioning properly. Do not operate unless they are functioning properly.
- Before attempting to start the engine, disengage all blade attachment clutches, shift into neutral, and engage the parking brake. Only start the engine from the operator's position. Never remove the ROPS and always wear the seat belts during operation.
- Do not put hands or feet near or under rotating parts. Keep clear of the discharge opening at all times.
- Remember there is no such thing as a safe slope. Travel on grass slopes requires particular care. Do the following to guard against overturning:
  - Do not stop or start suddenly when going up or downhill.
  - Keep machine speeds low on slopes and during tight turns.
  - Stay alert for humps and hollows and other hidden hazards.
  - Never mow across the face of the slope, unless the mower is designed for this purpose.
- Stay alert for holes in the terrain and other hidden hazards.
- Watch out for traffic when crossing or near roadways.
- Stop the blades from rotating before crossing surfaces other than grass.
- When using any attachments, never direct discharge of material toward bystanders nor allow anyone near the machine while in operation.
- Never operate the machine with damaged guards, shields, or without safety protective devices in place. Be sure all interlocks are attached, adjusted properly, and functioning properly.
- Do not change the engine governor settings or overspeed the engine. Operating the engine at excessive speed may increase the hazard of personal injury.
- Do the following before leaving the operator's position:
  - Stop on level ground.
  - Disengage the power take-off and lower the attachments.
  - Change into neutral and set the parking brake.
  - Stop the engine and remove the key.
- Disengage the drive to attachments, stop the engine, and remove the ignition key in the following conditions:
  - Before making height adjustments, unless the adjustment can be made from the operator's position.
  - Before clearing blockages

## Operation

- Do not operate the engine in a confined space where dangerous carbon monoxide fumes can collect.
- Mow only in daylight or in good artificial light.

- Before checking, cleaning, or working on the mower
- After striking a foreign object or if an abnormal vibration occurs (check immediately). Inspect the mower for damage and make repairs before restarting and operating the equipment. Torque all the spindle pulley nuts to 130 to 150 ft-lb (176 to 203 N-m).
- Disengage the drive to attachments when transporting or when not machine is not in use.
- Stop the engine and disengage the drive to attachments before the following:
  - Refueling
  - Making height adjustment, unless the adjustment can be made from the operator's position
- Reduce the throttle setting before stopping the engine and, if the engine is provided with a fuel shut-off valve, turn the fuel off at the conclusion of mowing.
- Never raise the cutting unit with the blades running.
- Keep hands and feet away from the cutting units.
- Look behind and down before backing up to be sure of a clear path.
- Slow down and use caution when making turns and crossing roads and sidewalks.
- Do not operate the mower under the influence of alcohol or drugs.
- Use care when loading or unloading the machine into a trailer or truck.
- The operator shall turn on flashing warning lights, if provided, whenever traveling on a public road, except where such use is prohibited by law.
- When machine is to be parked, stored, or left unattended, lower the cutting units unless a positive mechanical lock is provided.
- Disengage drives, lower the cutting units, set parking brake, stop engine and remove key. Wait for all movement to stop before adjusting, cleaning or repairing.
- Shut off fuel while storing or transporting. Do not store fuel near flames.
- Park the machine on level ground. Never allow untrained personnel to service machine.
- Use jack stands to support components when required.
- Carefully release pressure from components with stored energy.
- Disconnect battery before making any repairs. Disconnect the negative terminal first and the positive last. Reconnect positive first and negative last.
- Use care when checking the blades. Wrap the blades or wear gloves, and use caution when servicing them. Only replace blades. Never straighten or weld them.
- Keep hands and feet away from moving parts. If possible, do not make adjustments with the engine running.
- Charge batteries in an open well ventilated area, away from spark and flames. Unplug charger before connecting or disconnecting from battery. Wear protective clothing and use insulated tools.

## Maintenance and Storage

- Keep all nuts, bolts and screws tight to be sure the equipment is in safe working condition.
- Never store the equipment with fuel in the tank inside a building where fumes may reach an open flame or spark.
- Allow the engine to cool before storing in any enclosure.
- To reduce the fire hazard, keep the engine, silencer/muffler, battery compartment fuel storage area, cutting units and drives free of grass, leaves, or excessive grease. Clean up oil or fuel spillage.
- Replace worn or damaged parts for safety.
- If the fuel tank has to be drained, do this outdoors.
- On multi-bladed machines, take care as rotating one blade can cause other blades to rotate.

## Toro Mower Safety

The following list contains safety information specific to Toro products or other safety information that you must know that is not included in the CEN, ISO, or ANSI standards.

This product is capable of amputating hands and feet and throwing objects. Always follow all safety instructions to avoid serious injury or death.

Use of this product for purposes other than its intended use could prove dangerous to user and bystanders.



**Engine exhaust contains carbon monoxide, which is an odorless, deadly poison that can kill you. Do not run engine indoors or in an enclosed area.**

## Preparation

Be sure to establish your own special procedures and work rules for unusual operating conditions (e.g., slopes too steep for operation). **Survey the complete mowing site to determine which hills can be safely operated on.** When performing this site survey, always use common sense and take into consideration the turf condition and the rollover risk. To determine which hills or slopes may be safely operated on, use the inclinometer provided with each machine. To perform a site survey, follow the procedure outlined in the Operation section of this manual. **The maximum side hill angle is detailed on the slope decal affixed near the angle indicator.**

## Training

The operator must be skilled and trained in how to drive on hillsides. Failure to use caution on slopes or hills may cause the vehicle to tip or roll, possibly resulting in personal injury or death.

## Operation

- Know how to stop the machine and engine quickly.
- Do not operate the machine while wearing tennis shoes or sneakers.
- Wearing safety shoes and long pants is advisable and required by some local ordinances and insurance regulations.
- Keep hands, feet, and clothing away from moving parts and the mower discharge area.
- Fill the fuel tank until level is 1/2 inch (12 mm) below the bottom of the filler neck. Do not overfill.
- Check the safety interlock switches daily for proper operation. If a switch should fail, replace the switch before operating the machine.
- When starting the engine, engage the parking brake, put the traction pedal in neutral, and disengage the blade drive. After the engine starts, release the parking brake and keep your foot off of the traction pedal. The machine must not move. If movement is evident, refer to the Maintenance section of this manual to adjust the traction drive.
- Use extreme caution when operating close to sand traps, ditches, creeks, steep hillsides, or other hazards.
- Reduce speed when making sharp turns.
- Do not turn on hills.
- Do not operate on a side hill that is too steep. A rollover may occur before losing traction.
- The slope angle at which the machine will tip is dependent on many factors. Among these are

mowing conditions such as wet or undulating terrain, speed (especially in turns), position of the cutting units (with the Sidewinder), tire pressure, and operator experience. At side hill angles of 15 degrees or less, the risk of a rollover is low. As the slope angle increases to a recommended maximum limit of 20 degrees, the risk of a rollover increases to a moderate level. **Do not exceed a 20 degree side hill slope angle because the risk of a rollover and serious injury or death is very high.**

- For steering control, lower the cutting units when going down slopes.
- Avoid sudden stops and starts.
- Use the reverse pedal for braking.
- Watch for traffic when near or crossing roads. Always yield the right-of-way.
- Raise the cutting units when driving from one work area to another.
- Do not touch the engine, muffler, exhaust pipe, or hydraulic tank while the engine is running or soon after it has stopped because these areas could be hot enough to cause burns.
- This machine is not designed or equipped for on-road use and is a slow-moving vehicle. If you must cross or travel on a public road, you should be aware of and comply with local regulations, such as required lights, slow moving vehicle signs, and reflectors.

## Maintenance and Storage

- Before servicing or making adjustments, stop the engine and remove the ignition key.
- Ensure that the entire machine is properly maintained and in good operating condition. Frequently check all nuts, bolts, screws, and hydraulic fittings.
- Make sure all hydraulic line connectors are tight and all hydraulic hoses and lines are in good condition before applying pressure to the system.
- Keep your body and hands away from pin hole leaks or nozzles that eject hydraulic fluid under high pressure. Use paper or cardboard, not your hands, to search for leaks. Hydraulic fluid escaping under pressure can have sufficient force to penetrate the skin and cause serious injury. If fluid is injected into the skin it must be surgically removed within a few hours by a doctor familiar with this form of injury or gangrene may result.
- Before disconnecting or performing any work on the hydraulic system, all pressure in the system must be relieved by stopping the engine and lowering the cutting units to the ground.

- If the engine must be running to perform a maintenance adjustment, keep hands, feet, clothing, and any parts of the body away from the cutting units, attachments, and any moving parts. Keep everyone away.
- Do not overspeed the engine by changing governor settings. To ensure safety and accuracy, have an Authorized Toro Distributor check the maximum engine speed with a tachometer.
- The engine must be shut off before checking the oil or adding oil to the crankcase.
- If major repairs are ever needed or if assistance is desired, contact an Authorized Toro Distributor.
- To ensure optimum performance and continued safety certification of the machine, use only genuine Toro replacement parts and accessories. Replacement parts and accessories made by other manufacturers could be dangerous, and such use could void the product warranty.

## Sound Power Level

This unit has a guaranteed sound power level of 105 dBA, based on measurements of identical machines per ISO 11094.

## Sound Pressure Level

This unit has an equivalent continuous A-weighted sound pressure level at the operator ear of 89 dBA based on measurements of identical machines per EN 836 and ISO 11201.

## Vibration Level

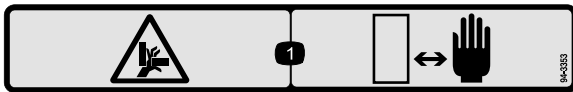
This unit does not exceed a vibration level of 2.5 m/s<sup>2</sup> at the hands based on measurements of identical machines per EN836 and EN 1033.

This unit does not exceed a vibration level of 0.5 m/s<sup>2</sup> at the posterior based on measurements of identical machines per EN 836 and EN 1032.

## Safety and Instructional Decals

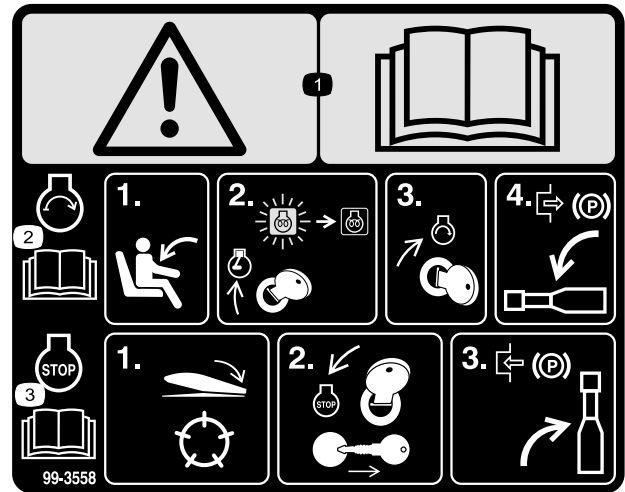


Safety decals and instructions are easily visible to the operator and are located near any area of potential danger. Replace any decal that is damaged or lost.



94-3353

1. Crushing hazard of hand—keep your hands a safe distance away.



99-3558

(CE Only)

1. Warning—read the *Operator's Manual*.
2. To start the engine, sit on the seat and rotate the ignition key to On/Preheat until the glow plug indicator light goes out. Rotate the key to start and disengage the parking brake. Read the *Operator's Manual* for further instructions.
3. To stop the engine, disengage the cutting units, rotate the ignition key to Off, and remove the key. Engage the parking brake. Read the *Operator's Manual* for further instructions.



100-4837



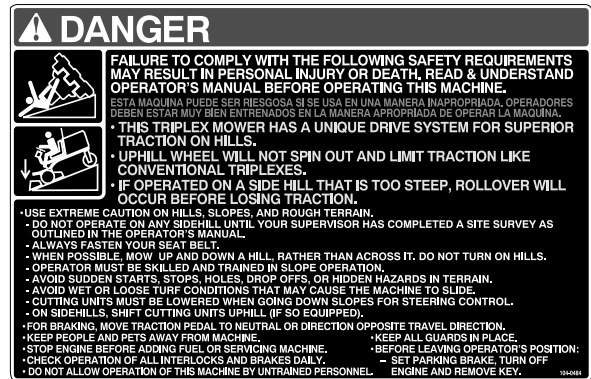
107-7801  
(CE Only)

1. Tipping hazard—do not drive on slopes greater than 15 degrees.

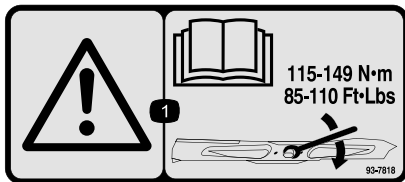


93-7276

1. Explosion hazard—wear eye protection.
2. Caustic liquid/chemical burn hazard—to perform first aid, flush with water.
3. Fire hazard—no fire, open flames, or smoking.
4. Poison hazard—keep children a safe distance from the battery.

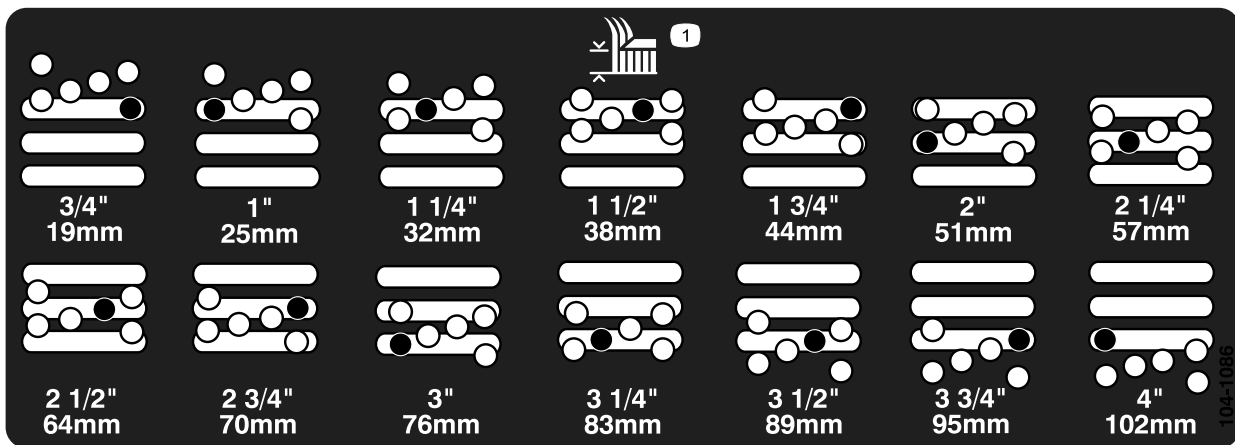


104-0484



93-7818

1. Warning—read the *Operator's Manual* for instructions on torquing the blade bolt/nut to 115-149 N·m (85-110 ft-lb).

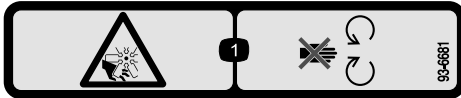


104-1086

1. Height of cut

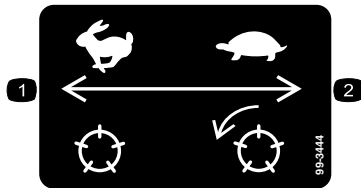


43-8480



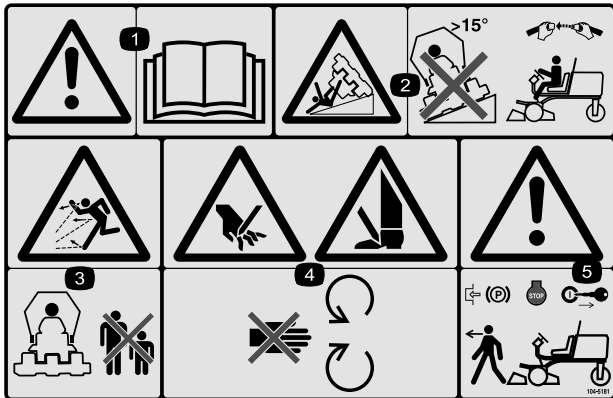
93-6681

1. Cutting/dismemberment—hazard, fan-stay away from moving parts.



99-3444

1. Reel speed—fast
2. Reel speed—slow



104-5181  
(CE Only)

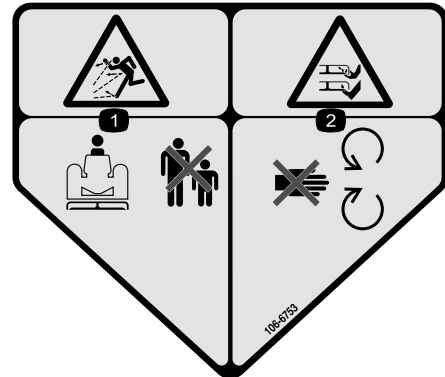
1. Warning—read the *Operator's Manual*.
2. Tipping hazard—do not drive on slopes greater than 15 degrees and, if the roll bar is installed, wear the seat belt.
3. Thrown object hazard—keep bystanders a safe distance from the machine.
4. Cutting hazard of hand or foot—stay away from moving parts.
5. Warning—lock the parking brake, stop the engine, and remove the ignition key before leaving the machine.



### Battery Symbols

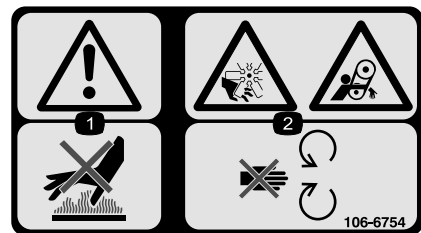
Some or all of these symbols are on your battery

1. Explosion hazard
2. No fire, open flame, or smoking.
3. Caustic liquid/chemical burn hazard
4. Wear eye protection
5. Read the *Operator's Manual*.
6. Keep bystanders a safe distance from the battery.
7. Wear eye protection; explosive gases can cause blindness and other injuries
8. Battery acid can cause blindness or severe burns.
9. Flush eyes immediately with water and get medical help fast.
10. Contains lead; do not discard.



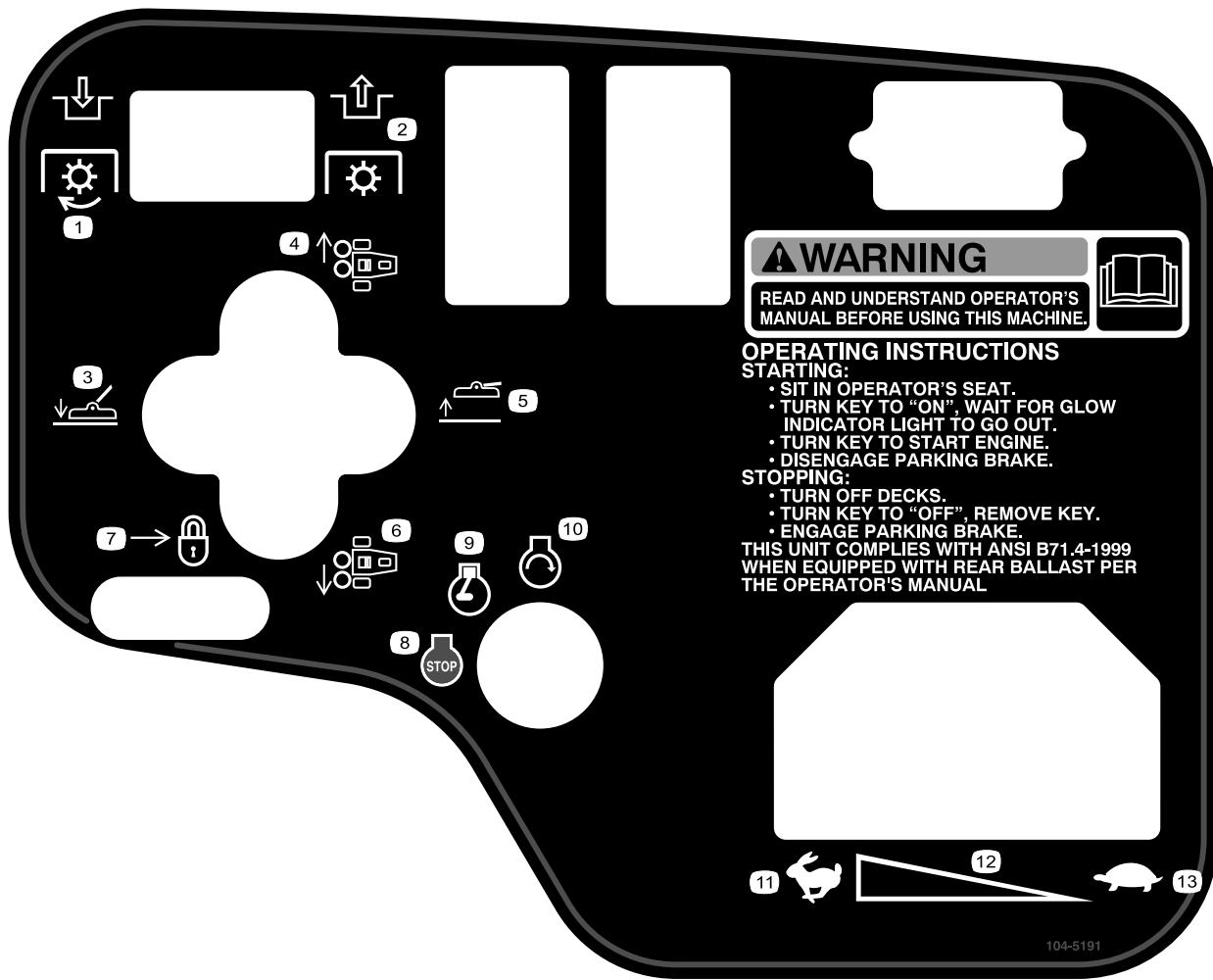
106-6753  
(CE Only)

1. Thrown object hazard—keep bystanders a safe distance from the machine.
2. Cutting/dismemberment hazard of hand or foot, mower blade—stay away from moving parts.



106-6754

1. Warning—do not touch the hot surface.
2. Cutting/dismemberment hazard, fan and entanglement hazard, belt—stay away from moving parts.

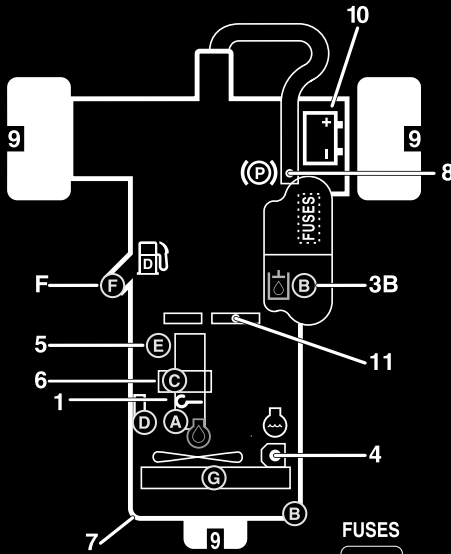


**104-5191**

- |   |   |                                 |          |
|---|---|---------------------------------|----------|
| 1. Engage the power take off (PTO).     | 5. Raise the cutting units.               | 9. Engine—run                   | 13. Slow |
| 2. Disengage the power take off (PTO).  | 6. Move the cutting units to the left.    | 10. Engine—start                |          |
| 3. Lower the cutting units.             | 7. Move rear ward to lock the lift lever. | 11. Fast                        |          |
| 4. Move the cutting units to the right. | 8. Engine—stop                            | 12. Continuous variable setting |          |

# GROUNDMASTER 3500-D

## QUICK REFERENCE AID



### CHECK/SERVICE (DAILY)

1. OIL LEVEL, ENGINE
2. ENGINE OIL DRAIN (3/4" OR 19mm SOCKET)
3. OIL LEVEL HYDRAULIC TANK
4. COOLANT LEVEL, RADIATOR
5. FUEL/WATER SEPARATOR
6. AIR CLEANER

7. RADIATOR SCREEN
8. PARKING BRAKE
9. TIRE PRESSURE (14-18 psi)
10. BATTERY
11. BELTS (FAN, ALTERNATOR, HYDRAULIC PUMP)

GREASING - SEE OPERATOR'S MANUAL

### FLUID SPECIFICATIONS/CHANGE INTERVALS

SEE OPERATOR'S MANUAL FOR INITIAL CHANGES.	FLUID TYPE	CAPACITY	CHANGE INTERVAL		FILTER PART NO.
			FLUID	FILTER	
A. ENGINE OIL	SAE 15W-40 CH-4	4.0 QTS.*	150 HRS.	150 HRS.	104-5167
B. HYD. CIRCUIT OIL	MOBIL DTE15M	6 GAL.*	400 HRS.	200 HRS.	86-3010
C. AIR CLEANER				200 HRS.	98-9763
D. FILTER, IN-LINE FUEL				400 HRS.	98-7612
E. WATER SEPARATOR				400 HRS.	98-9764
F. FUEL TANK	NO. 2-DIESEL	11 GALS.	DRAIN AND FLUSH, 2 YRS.		
G. COOLANT	50/50 ETHYLENE GLYCOL/WATER	6 QTS.	DRAIN AND FLUSH, 2 YRS.		

\* INCLUDING FILTER

107-7800

### FUSES

MAIN  
**15A**

MAX  
**15A**  
OPTIONAL  
LIGHT

SYSTEM  
**10A**  
GAUGES  
SCM PTO

**2A**  
SCM

START  
**10A**

107-7800

# Setup

## Loose Parts

Use the chart below to verify that all parts have been shipped.

Procedure	Description	Qty.	Use
<b>2</b>	Inclinometer	1	Check the angle indicator.
<b>3</b>	Hood lock bracket Screw, 1/4 x 1–1/2 inches Flat washer, 1/4 inch Locknut, 1/4 inch	1 1 1 1	Install the Hood Latch (CE).
<b>4</b>	Exhaust guard Self-tapping screw	1 4	Install the Exhaust Guard (CE).
<b>5</b>	No parts required	–	Adjust the lift arms.
<b>6</b>	No parts required	–	Rear ballast.

## Media and Additional Parts

Description	Qty.	Use
Decal, CE	6	Affix to the machine over corresponding English decals for European compliance.
Ignition keys	2	Start the engine.
Operator's Manual	1	Read before operating the machine.
Engine Operator's Manual	1	
Parts Catalog	1	Use to look up and order parts.
Operator video	1	View before operating the machine.
Pre-delivery check list	1	Check to ensure that the machine has been properly set up.
Certificate of compliance	1	Ensure CE compliance.

Note: Determine the left and right sides of the machine from the normal operating position.

# 1

## Activating, Charging, and Connecting the Battery

No Parts Required

### Procedure

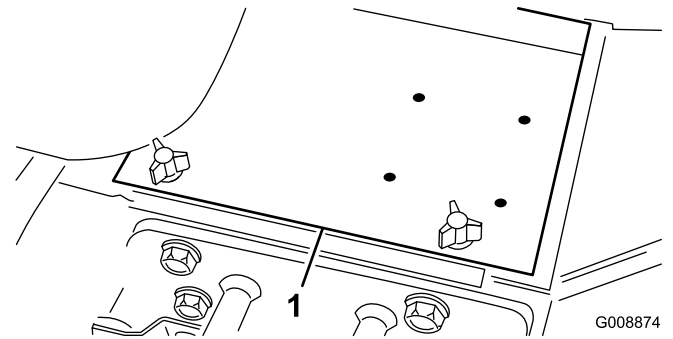


Figure 3

1. Battery cover

### Warning

#### CALIFORNIA

#### Proposition 65 Warning

Battery posts, terminals, and related accessories contain lead and lead compounds, chemicals known to the State of California to cause cancer and reproductive harm. Wash hands after handling.

**Note:** If the battery is not filled with electrolyte or activated, bulk electrolyte with 1.260 specific gravity must be purchased from a local battery supply outlet and added to the battery.



Battery electrolyte contains sulfuric acid which is a deadly poison and causes severe burns.

- Do not drink electrolyte and avoid contact with skin, eyes, or clothing. Wear safety glasses to shield your eyes and rubber gloves to protect your hands.
- Fill the battery where clean water is always available for flushing the skin.

1. Open the hood.
2. Remove the battery cover (Figure 3).

3. Remove the filler caps from the battery and slowly fill each cell until electrolyte is just above the plates.
4. Install the filler caps and connect a 3 to 4 amp battery charger to the battery posts. Charge the battery at a rate of 3 to 4 amperes for 4 to 8 hours.



Charging the battery produces gasses that can explode.

- Keep sparks and flames away from battery.
- Never smoke near the battery.

5. When the battery is charged, disconnect the charger from the electrical outlet and battery posts.
6. Remove the filler caps. Slowly add electrolyte to each cell until the level is up to the fill ring. Install the filler caps.

**Important:** Do not overfill the battery. Electrolyte will overflow onto other parts of the machine and severe corrosion and deterioration will result.

7. Install the positive cable (red) to the positive (+) terminal and the negative cable (black) to the negative (-) terminal of the battery and secure them with bolts and nuts (Figure 4). Make sure that the positive (+) terminal is all of the way onto the post and the cable is positioned snug to the battery. The cable must not contact the battery cover.



Incorrect battery cable routing could damage the tractor and cables causing sparks. Sparks can cause the battery gasses to explode, resulting in personal injury.

- Always disconnect the negative (black) battery cable before disconnecting the positive (red) cable.
- Always connect the positive (red) battery cable before connecting the negative (black) cable.

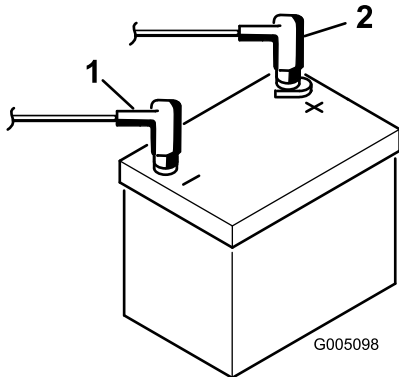


Figure 4

1. Positive (+) battery cable    2. Negative (-) battery cable

**Important:** If the battery is ever removed, make sure that the battery clamp bolts are installed with the bolt heads positioned on the bottom side and the nuts on the top side. If the clamp bolts are reversed, they may interfere with the hydraulic tubes when shifting the cutting units.

8. Coat both battery connections with Grafo 112X (skin over) grease, Toro Part No. 505-47, petroleum jelly, or light grease to prevent corrosion.
9. Slide the rubber boot over the positive terminal to prevent a possible short from occurring.
10. Install the battery cover.

## 2

### Checking the Angle Indicator

#### Parts needed for this procedure:

1	Inclinometer
---	--------------

#### Procedure



To reduce risk of injury or death due to rollover, do not operate the machine on side hills steeper than 25°.

1. Park the machine on a flat, level surface.
2. Verify that the machine is level by placing a hand held inclinometer (supplied with the machine) on the frame cross rail, by the fuel tank (Figure 5). The inclinometer should read zero degrees when viewed from the operator's position.

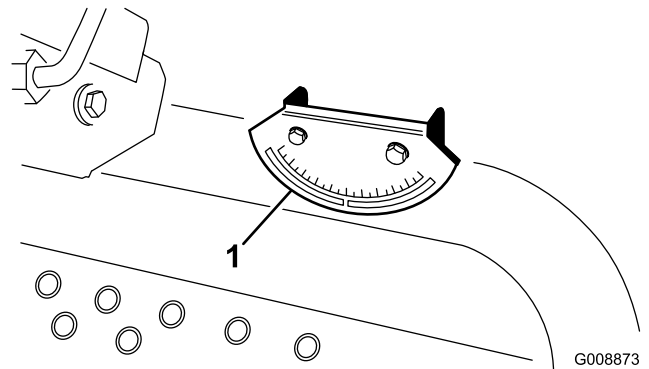


Figure 5

1. Angle indicator
3. If the inclinometer does not read zero degrees, move the machine to a location where a zero degree reading is obtained. The angle indicator, mounted on the machine, should now read zero degrees as well.
4. If the angle indicator does not read zero degrees, loosen the two screws and nuts securing the angle indicator to the mounting bracket, adjust the indicator to obtain a zero degree reading, and tighten the bolts.

# 3

## Installing the Hood Latch (CE Only)

### Parts needed for this procedure:

1	Hood lock bracket
1	Screw, 1/4 x 1-1/2 inches
1	Flat washer, 1/4 inch
1	Locknut, 1/4 inch

### Procedure

1. Unhook the hood latch from the hood latch bracket (Figure 6).

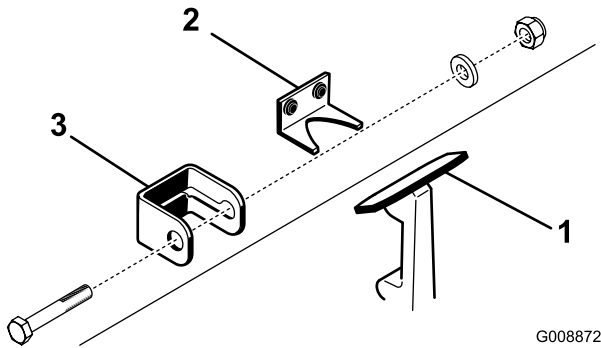


Figure 6

1. Hood latch
2. Hood latch bracket
3. Hood lock bracket

2. Slide the hood lock bracket onto the latch (Figure 6).
3. Hook the latch onto the hood latch bracket (Figure 6).
4. Insert a bolt (1/4 x 1-1/2 inches) through the hood lock bracket and secure it with a flat washer and locknut (Figure 6).

# 4

## Installing the Exhaust Guard (CE Only)

### Parts needed for this procedure:

1	Exhaust guard
4	Self-tapping screw

### Procedure

1. Position the exhaust guard around the muffler while aligning the mounting holes with the holes in the frame (Figure 7).

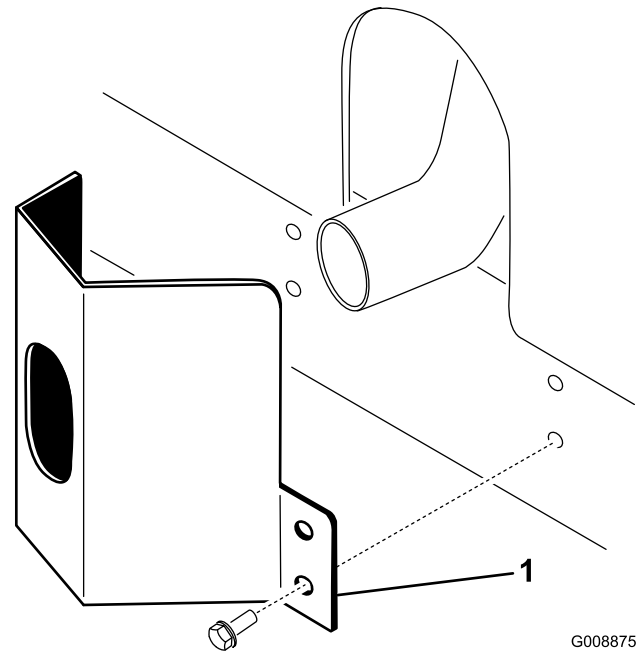


Figure 7

1. Exhaust guard
2. Secure the exhaust guard to the frame with 4 self-tapping screws (Figure 7).

# 5

## Adjusting the Lift Arms

### No Parts Required

### Procedure

1. Start the engine, raise the cutting units, and check to ensure that the clearance between each lift arm and the floor plate bracket is 0.18 to 0.32 inches (5 to 8 mm) (Figure 8).

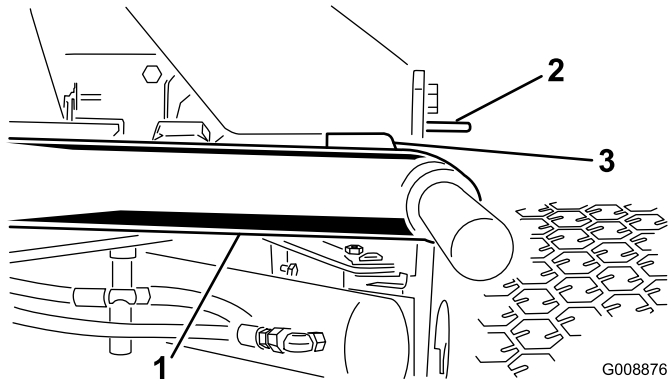


Figure 8

cutting units removed for clarity

1. Lift arm
2. Floor plate bracket
3. Clearance

If the clearance is not in this range, adjust it as follows:

- A. Back off the stop bolts (Figure 9).

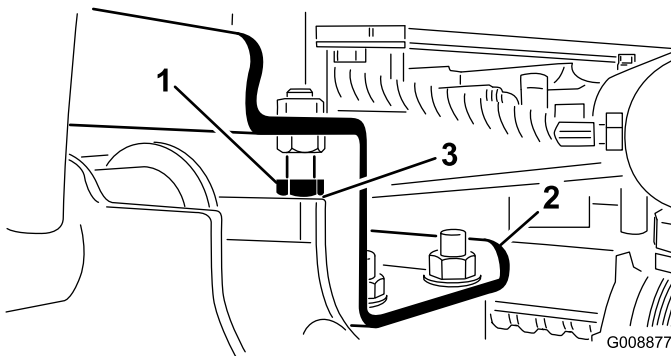


Figure 9

1. Stop bolt
2. Lift arm
3. Clearance

- B. Back off the jam nut on the cylinder (Figure 10).

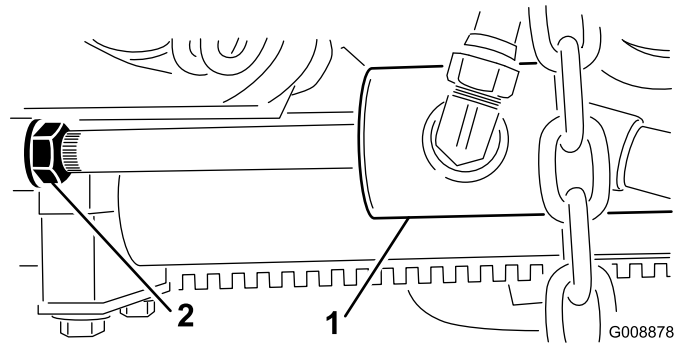


Figure 10

1. Front cylinder
2. Jam nut

- C. Remove the pin from the rod end and rotate the clevis.

- D. Install the pin and check the clearance. Repeat the procedure if required.

- E. Tighten the clevis jam nut.

2. Check to make sure that the clearance between each lift arm and stop bolt is 0.005 to 0.040 inches (0.13 to 1.02 mm) (Figure 9). If the clearance is not in this range, adjust the stop bolts to attain clearance.

3. Start the engine, raise the cutting units, and check to make sure that the clearance between the wear strap on the top of the rear cutting unit wear bar and the bumper strap is 0.02 to 0.10 inches (0.51 to 2.54 mm) (Figure 11).

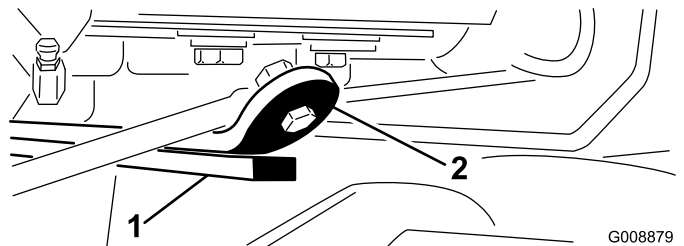


Figure 11

1. Wear bar
2. Bumper strap

If the clearance is not in this range, adjust the rear cylinder as follows:

**Note:** If the rear lift arm clunks during transport, clearance can be reduced.

- A. Lower the cutting units and back off the jam nut on the cylinder (Figure 12).

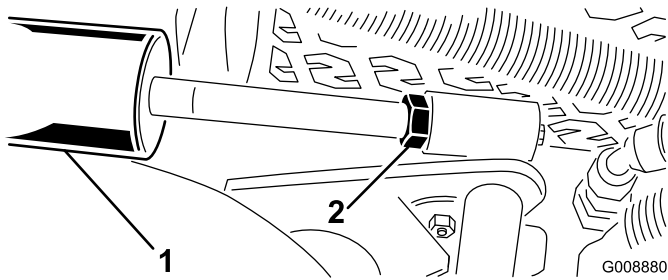


Figure 12

1. Rear cylinder
2. Adjusting nut

- B. Grasp the cylinder rod close to the nut with a pliers and rag and rotate the rod.
- C. Raise the cutting units and check the clearance. Repeat the procedure if required.
- D. Tighten the clevis jam nut.

**Important:** Lack of clearance at the front stops or rear wear bar could damage the lift arms.

# 6

## Rear Ballast

### No Parts Required

### Procedure

This machine conforms to the B71.4-1999 standard when 50 lb (22.6 kg) of calcium chloride ballast is added to the rear wheels.

**Important:** If a puncture occurs in a tire with calcium chloride, remove the machine from the turf as quickly as possible. To prevent possible damage to the turf, immediately soak the affected area with water.

# Product Overview

## Controls

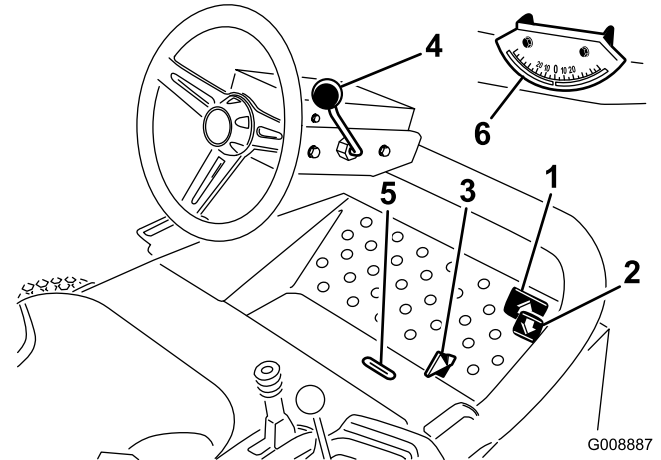


Figure 13

- |                           |                        |
|---------------------------|------------------------|
| 1. Forward traction pedal | 4. Tilt steering lever |
| 2. Reverse traction pedal | 5. Indicator slot      |
| 3. Mow/transport slide    | 6. Angle indicator     |

## Traction Pedals

Press the traction forward pedal (Figure 13) to move forward. Press traction reverse pedal (Figure 13) to move backward or to assist in stopping when moving forward. Also, allow the pedal to move or move it to the neutral position to stop the machine.

## Mow/Transport Slide

Using your heel, move the mow/transport slide (Figure 13) to the left to transport and to the right to mow. **The cutting units will only operate in the mow position.**

**Important:** The mow speed is set at the factory to 6 MPH (9.7 km/h). It can be increased or decreased by adjusting the speed stop screw (Figure 14).

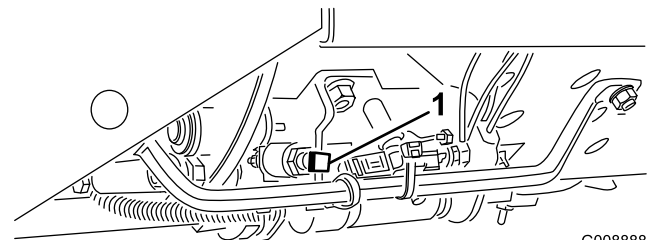


Figure 14

1. Speed stop screw

## Tilt Steering Lever

Pull the tilt steering lever (Figure 13) back to tilt the steering wheel to the desired position. Then push the lever forward to tighten.

## Indicator Slot

The slot in the operator platform (Figure 13) indicates when the cutting units are in the center position.

## Angle Indicator

The angle indicator (Figure 13) indicates the side hill angle of the machine in degrees.

## Ignition Switch

The ignition switch (Figure 15), used to start, stop, and preheat the engine, has three positions: Off, On/Preheat, and Start. Rotate the key to the On/Preheat position until the glow plug indicator light goes out (approximately 7 seconds); then rotate the key to the Start position to engage the starter motor. Release the key when the engine starts. The key will move automatically to the On/Run position. To shut the engine off, rotate the key to the Off position. Remove the key from the switch to prevent accidental starting.

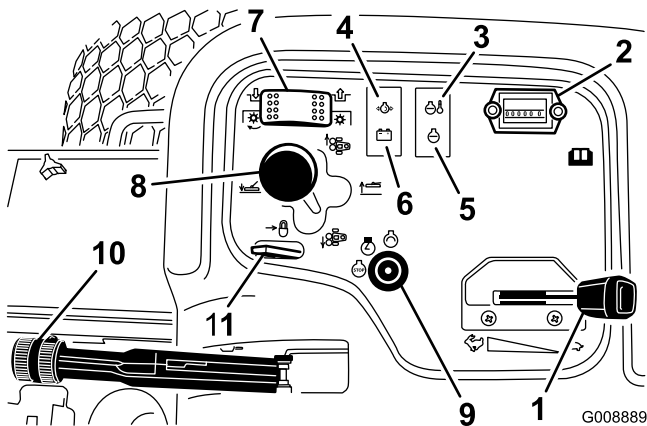


Figure 15

- |                              |                              |
|------------------------------|------------------------------|
| 1. Throttle                  | 7. Cutting unit drive switch |
| 2. Hour meter                | 8. Cutting unit shift lever  |
| 3. Temperature light         | 9. Ignition switch           |
| 4. Oil pressure light        | 10. Parking brake            |
| 5. Glow plug indicator light | 11. Lift lever lock          |
| 6. Alternator light          |                              |

## Throttle

Move the throttle (Figure 15) forward to increase the engine speed and rearward to decrease the engine speed.

## Cutting Unit Drive Switch

The cutting unit drive switch (Figure 15) has two positions: Engage and Disengage. The rocker switch operates a solenoid valve on the valve bank to drive the cutting units.

## Hour Meter


The hour meter (Figure 15) indicates the total hours of machine operation. The hour meter starts to function whenever the key switch is On.

## Cutting Unit Shift Lever

To lower the cutting units to the ground, move the cutting unit shift lever (Figure 15) forward. The cutting units will not drop unless the engine is running. To raise the cutting units, pull the shift lever rearward to the Raise position.

Move the lever to the right or left to move the cutting units in the same direction. This should only be done when the cutting units are raised or if they are on the ground and the machine is moving.

**Note:** The lever does not have to be held in the forward position while the cutting units are lowered.



**Shifting the cutting units downhill decreases machine stability. This could cause a rollover, which may result in personal injury or death.**

**Shift the cutting units uphill while on a side hill.**

## Engine Coolant Temperature Warning Light

The temperature warning light (Figure 15) glows if the engine coolant temperature is high. If the traction unit is not stopped and the coolant temperature rises another 10° F, the engine will kill.

## Oil Pressure Warning Light

The oil pressure warning light (Figure 15) glows if the engine oil pressure drops below a safe level.

## Alternator Light

The alternator light (Figure 15) should be off when the engine is running. If it is on, the charging system should be checked and repaired as necessary.

## Glow Plug Indicator

The glow plug indicator light (Figure 15) will glow when the glow plugs are operating.

## Parking Brake

Whenever the engine is shut off, engage the parking brake (Figure 15) to prevent accidental movement of the machine. To engage the parking brake, pull up on the lever. The engine will stop if you press the traction pedal with the parking brake engaged.

## Lift Lever Lock

Move the lift lever lock (Figure 15) rearward to prevent the cutting units from dropping.

## Fuel Gauge

The fuel gauge (Figure 16) registers the amount of fuel in the tank.

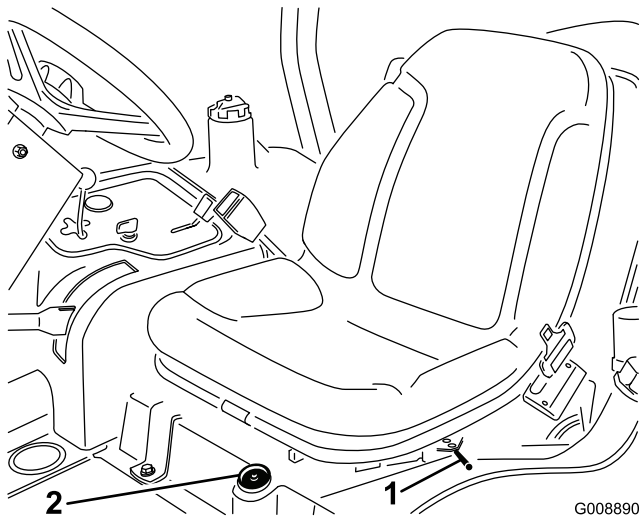


Figure 16

1. Fore and aft lever
2. Fuel gauge

## Fore and Aft Seat Adjustments

Move the lever (Figure 16) on the side of the seat outward, slide the seat to the desired position, and release the lever to lock the seat into position.

## Specifications

**Note:** Specifications and design are subject to change without notice.

Overall Width - 68 inch width of cut	71.8 inches (182 cm)
Overall Width - 72 inch width of cut	75.8 inches (193 cm)
Length	116 inches (295 cm)
Height to top of ROPS	70.8 inches (180 cm)
Wheel Base	58.5 inches (149 cm)
Track Width	57 inches (145 cm)
Ground Clearance	6 inches (15.3 cm)
Weight with cutting units	2200 lb (1000 kg)

## Attachments/Accessories

A selection of Toro approved attachments and accessories are available for use with the machine to enhance and expand its capabilities. Contact your Authorized Service Dealer or Distributor or go to [www.Toro.com](http://www.Toro.com) for a list of all approved attachments and accessories.

# Operation

**Note:** Determine the left and right sides of the machine from the normal operating position.

## Checking the Engine Oil Level

**Service Interval:** Before each use or daily

The engine is shipped with oil in the crankcase; however, the oil level must be checked before and after the engine is first started.

Crankcase capacity is approximately 4 qt (2.8 l) with the filter.

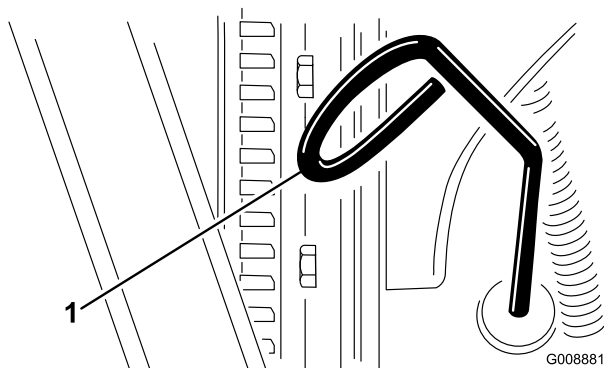
Use high-quality engine oil that meets the following specifications:

- API Classification Level Required: CH-4, CI-4 or higher.
- Preferred oil: SAE 15W-40 (above 0°F (-17°C))
- Alternate oil: SAE 10W-30 or 5W-30 (all temperatures)

**Note:** Toro Premium Engine oil is available from your distributor in either 15W-40 or 10W-30 viscosity. See the parts catalog for part numbers.

**Note:** The best time to check the engine oil is when the engine is cool before it has been started for the day. If it has already been run, allow the oil to drain back down to the sump for at least 10 minutes before checking. If the oil level is at or below the “add” mark on the dipstick, add oil to bring the oil level to the “full” mark. **DO NOT OVERFILL.** If the oil level is between the “full” and “add” marks, no oil addition is required.

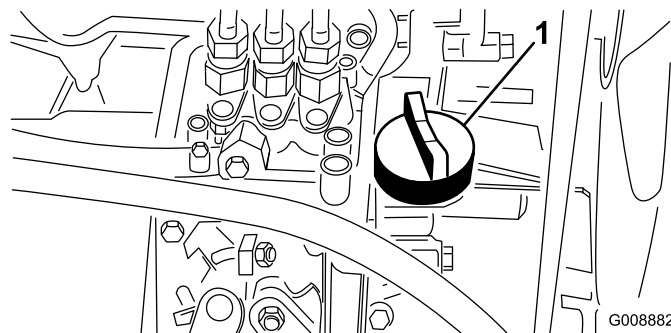
1. Position the machine on a level surface.
2. Remove the dipstick (Figure 17) and wipe it with a clean rag.



**Figure 17**

1. Dipstick

3. Push the dipstick down into the dipstick tube and make sure that it is seated fully. Pull the dipstick out and check the oil level.
4. If the oil level is low, remove the oil fill cap (Figure 18) and gradually add small quantities of oil, checking the level frequently, until the level reaches the Full mark on the dipstick.



**Figure 18**

1. Oil fill cap

5. Install the oil fill cap and close the hood.

## Filling the Fuel Tank

Use only clean, fresh diesel fuel or biodiesel fuels with low (<500 ppm) or ultra low (<15 ppm) sulfur content. The minimum cetane rating should be 40. Purchase fuel in quantities that can be used within 180 days to ensure fuel freshness.

The fuel tank capacity is approximately 11 gallons (42 liters).

Use summer grade diesel fuel (No. 2-D) at temperatures above 20 degrees F (-7 degrees C) and winter grade (No. 1-D or No. 1-D/2-D blend) below that temperature. Use of winter grade fuel at lower temperatures provides lower flash point and cold flow characteristics which will ease starting and reduce fuel filter plugging.

Use of summer grade fuel above 20 degrees F (-7 degrees C) will contribute toward longer fuel pump life and increased power compared to winter grade fuel.

### Biodiesel Ready

This machine can also use a biodiesel blended fuel of up to B20 (20% biodiesel, 80% petrodiesel). The petrodiesel portion should be low or ultra low sulfur. Observe the following precautions:

- The biodiesel portion of the fuel must meet specification ASTM D6751 or EN14214.
- The blended fuel composition should meet ASTM D975 or EN590.

- Painted surfaces may be damaged by biodiesel blends.
  - Use B5 (biodiesel content of 5%) or lesser blends in cold weather
  - Monitor seals, hoses, gaskets in contact with fuel as they may be degraded over time.
  - Fuel filter plugging may be expected for a time after converting to biodiesel blends.
  - Contact your distributor if you wish for more information on biodiesel
1. Clean the area around the fuel tank cap (Figure 19).
  2. Remove the fuel tank cap.
  3. Fill the tank to the bottom of the filler neck. **Do not overfill.** Install the cap.
  4. To prevent a fire hazard, wipe up any fuel that may have spilled.

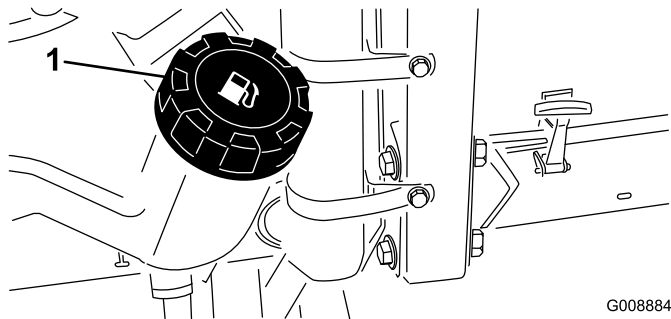


Figure 19

1. Fuel tank cap

## Checking the Cooling System

**Service Interval:** Before each use or daily

Clean debris off of the radiator and oil cooler daily (Figure 20). Clean the radiator hourly if conditions are extremely dusty and dirty; refer to Cleaning the Engine Cooling System.

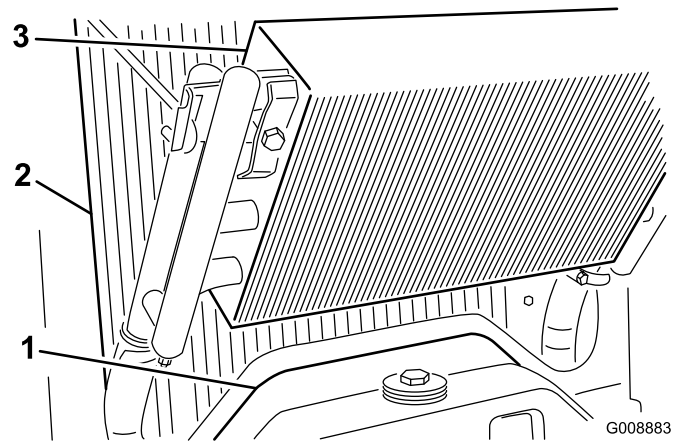


Figure 20

1. Access panel
2. Radiator
3. Oil cooler

The cooling system is filled with a 50/50 solution of water and permanent ethylene glycol anti-freeze. Check the coolant level at the beginning of each day before starting the engine.

The capacity of the cooling system is approximately 6 qt (5.7 l).



Under certain conditions, diesel fuel and fuel vapors are highly flammable and explosive. A fire or explosion from fuel can burn you and others and can cause property damage.

- Use a funnel and fill the fuel tank outdoors, in an open area, when the engine is off and is cold. Wipe up any fuel that spills.
- Do not fill the fuel tank completely full. Add fuel to the fuel tank until the level is 1/4 to 1/2 inch (6 to 13 mm) below the bottom of the filler neck. This empty space in the tank allows the fuel to expand.
- Never smoke when handling fuel, and stay away from an open flame or where fuel fumes may be ignited by a spark.
- Store fuel in a clean, safety-approved container and keep the cap in place.



If the engine has been running, the pressurized, hot coolant can escape and cause burns.

- Do not open the radiator cap when the engine is running.
- Use a rag when opening the radiator cap, and open the cap slowly to allow steam to escape.

1. Check the coolant level in the expansion tank (Figure 21). With a cold engine, the coolant level should be approximately midway between the marks on the side of the tank.
2. If the coolant level is low, remove the expansion tank cap and replenish the system. **Do not overfill.**
3. Install the expansion tank cap.



# Checking the Tire Pressure

**Service Interval:** Before each use or daily

The tires are over-inflated for shipping. Therefore, release some of the air to reduce the pressure. The correct air pressure in the tires is 14 to 18 psi (97 to 124 kPa).

**Note:** Maintain the recommended pressure in all tires to ensure a good quality of cut and proper machine performance.



**Low tire pressure decreases machine side hill stability. This could cause a rollover, which may result in personal injury or death.**

**Do not under-inflate the tires.**

# Torquing the Wheel Nuts

**Service Interval:** After the first hour

After the first 10 hours

Every 200 hours

Torque the wheel nuts to 45 to 65 ft-lb (61 to 88 N-m).



**Failure to maintain proper torque of the wheel nuts could result in personal injury.**

# Starting and Stopping the Engine

You may need to bleed the fuel system if any of the following situations have occurred (refer to Bleeding the Fuel System):

- Initial start up of a new engine
- The engine has ceased running due to lack of fuel.
- Maintenance has been performed upon the fuel system components; i.e. filter replaced, etc.

## Starting the Engine

1. Be sure that the parking brake is set and the cutting unit drive switch is in the Disengage position.
2. Remove your foot from the traction pedal and make sure that the pedal is in the neutral position.

3. Move the throttle lever to the 1/2 throttle position.
4. Insert the key into the switch and rotate it to the On/Preheat position until the glow plug indicator light goes out (approximately 7 seconds); then rotate the key to the Start position to engage the starter motor. Release the key when the engine starts. The key will move automatically to the On/Run position.

**Important:** To prevent overheating of the starter motor, do not engage the starter longer than 15 seconds. After 10 seconds of continuous cranking, wait 60 seconds before engaging the starter motor again.

5. When the engine is started for the first time or after an overhaul of the engine, operate the machine in forward and reverse for one to two minutes. Also operate the lift lever and cutting unit drive switch to be sure of proper operation of all parts.

Turn the steering wheel to the left and right to check steering response; then shut the engine off and check for oil leaks, loose parts, and any other noticeable malfunctions.



**Stop the engine and wait for all moving parts to stop before checking for oil leaks, loose parts, and other malfunctions.**

## Stopping the Engine

Move the throttle control to the Idle position, move the cutting unit drive switch to Disengage, and rotate the starter key to Off. Remove the key from the switch to prevent accidental starting.

## Bleeding the Fuel System

1. Park the machine on a level surface. Make sure that the fuel tank is at least half full.
2. Unlatch and raise the hood.



Under certain conditions, diesel fuel and fuel vapors are highly flammable and explosive. A fire or explosion from fuel can burn you and others and can cause property damage.

- Use a funnel and fill the fuel tank outdoors, in an open area, when the engine is off and is cold. Wipe up any fuel that spills.
- Do not fill the fuel tank completely full. Add fuel to the fuel tank until the level is 1/4 to 1/2 inch (6 to 13 mm) below the bottom of the filler neck. This empty space in the tank allows the fuel to expand.
- Never smoke when handling fuel, and stay away from an open flame or where fuel fumes may be ignited by a spark.
- Store fuel in a clean, safety-approved container and keep the cap in place.

3. Open the air bleed screw on the fuel injection pump (Figure 23).

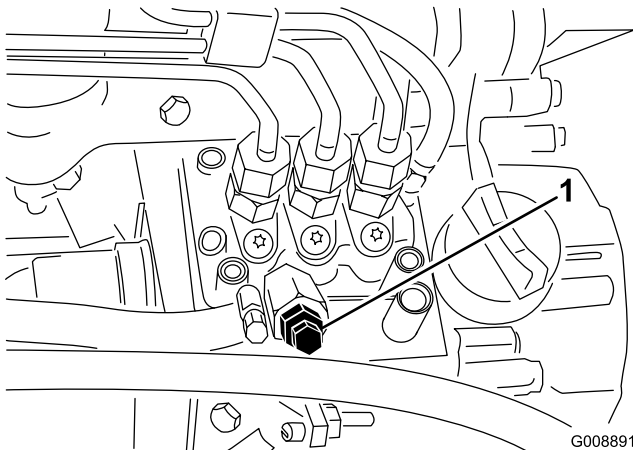


Figure 23

1. Fuel injection pump bleed screw

4. Turn the key in the ignition switch to the On position. The electric fuel pump will begin operation, thereby forcing air out around the air bleed screw. Leave the key in the On position until a solid stream of fuel flows out around the screw.
5. Tighten the screw and turn the key to Off.

**Note:** Normally the engine should start after the above bleeding procedures are followed. However, if the engine does not start, air may be trapped between the injection pump and injectors; refer to Bleeding Air from the Injectors.

## Checking the Interlock System

**Service Interval:** Before each use or daily



If safety interlock switches are disconnected or damaged the machine could operate unexpectedly causing personal injury.

- Do not tamper with the interlock switches.
- Check the operation of the interlock switches daily and replace any damaged switches before operating the machine.

1. Make sure that all bystanders are away from the area of operation. Keep hands and feet away from the cutting units.
2. While sitting on the seat, the engine must not start with either the cutting unit switch engaged or the traction pedal engaged. Correct the problem if it is not operating properly.
3. While sitting on the seat, put the traction pedal in neutral, the parking brake off, and the cutting unit switch in the Off position. The engine should start. Rise from the seat and slowly press the traction pedal, the engine should stop in one to three seconds. Correct problem if it is not operating properly.

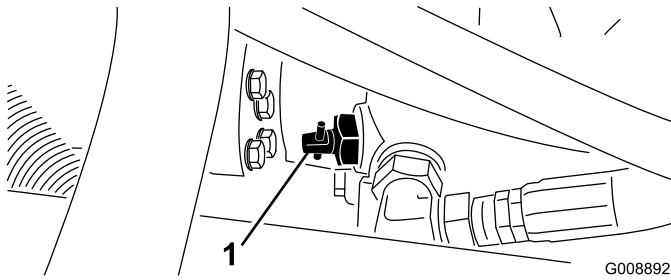
**Note:** The machine is equipped with an interlock switch on the parking brake. The engine will stop if the traction pedal is pressed with the parking brake engaged.

## Towing the Traction Unit

In case of an emergency, the machine can be towed for a short distance; however, Toro does not recommend this as a standard procedure.

**Important:** Do not tow the machine faster than 2 to 3 MPH (3 to 4 km/h) because the drive system may become damaged. If the machine must be moved a considerable distance, transport it on a truck or trailer.

1. Locate the bypass valve on the pump (Figure 24) and rotate it 90°.



**Figure 24**

1. Bypass valve
- 
2. Before starting the engine, close the bypass valve by rotating it 90° (1/4 turn). Do not start the engine when the valve is open.

## Standard Control Module (SCM)

The Standard Control Module is a potted electronic device produced in a one size fits all configuration. The module uses solid state and mechanical components to monitor and control standard electrical features required for safe product operation.

The module monitors inputs including neutral, parking brake, PTO, start, backlap, and high temperature. The module energizes outputs including PTO, Starter, and ETR (energize to run) solenoid.

The module is divided into inputs and outputs. Inputs and outputs are identified by green LED indicators mounted on the printed circuit board.

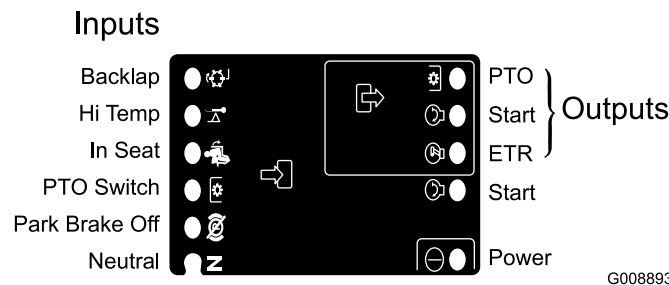
The start circuit input is energized by 12 VDC. All other inputs are energized when the circuit is closed to ground. Each input has a LED that is illuminated when the specific circuit is energized. Use the input LED's for switch and input circuit troubleshooting.

Output circuits are energized by an appropriate set of input conditions. The three outputs include PTO, ETR, and START. Output LED's monitor relay condition indicating the presence of voltage at one of three specific output terminals.

Output circuits do not determine output device integrity so electrical troubleshooting includes output LED inspection and conventional device and wire harness integrity testing. Measure disconnected component impedance, impedance through wire harness (disconnect at SCM), or by temporarily "test energizing" the specific component.

The SCM does not connect to an external computer or hand held device, can not be re-programmed, and does not record intermittent fault troubleshooting data.

The decal on the SCM only includes symbols. Three LED output symbols are shown in the output box. All other LED's are inputs. The chart below identifies the symbols.



**Figure 25**

Here are the logical troubleshooting steps for the SCM device.

1. Determine the output fault you are trying to resolve (PTO, START, or ETR).
2. Move key switch to the On position and ensure that the red power LED is illuminated.
3. Move all input switches to ensure all LED's change state.
4. Position input devices at appropriate position to achieve the appropriate output. Use the following logic chart to determine the appropriate input condition.

5. If specific output LED is illuminated without appropriate output function, check output harness, connections, and component. Repair as required.
6. If specific output LED is not illuminated, check both fuses.
7. If specific output LED is not illuminated and inputs are in appropriate condition, install new SCM and determine if fault disappears.

Each row (across) in the logic chart below identifies input and output requirements for each specific product function. Product functions are listed in the left column. Symbols identify specific circuit condition

including: energized to voltage, closed to ground, and open to ground.

INPUTS									OUTPUTS		
Function	Power ON	In Neutral	Start ON	Brake ON	PTO ON	In Seat	Hi Temp	Backlap	Start	ETR	PTO
Start	—	—	+	O	O	—	O	O	+	+	O
Run (Off Unit)	—	—	O	O	O	O	O	O	O	+	O
Run (On Unit)	—	O	O	—	O	—	O	O	O	+	O
Mow	—	O	O	—	—	—	O	O	O	+	+
Backlap	—	—	O	O	—	O	O	—	O	+	+
Hi Temp	—		O				—		O	O	O

- (–) Indicates a circuit closed to ground. – LED ON
- (O) Indicates a circuit open to ground or de-energized – LED OFF
- (+) Indicates an energized circuit (clutch coil, solenoid, or start input) LED ON.
- A Blank indicates a circuit that is not involved with the logic.

To troubleshoot, turn on the key without starting the engine. Identify the specific function that does not work and work across the logic chart. Inspect the condition of each input LED's to ensure it matches the logic chart.

If the input LED's are correct, check the output LED. If the output LED is illuminated but the device is not energized, measure available voltage at the output device, continuity of the disconnected device, and potential voltage on the ground circuit (floating ground). Repairs will vary depending on your findings.

# Operating Tips

## General Tips



The mower has a unique traction system that will allow the machine to move forward on side hills, even if the uphill wheel should come off of the ground. If this should happen, the operator or any bystanders can be seriously injured or killed in a rollover.

The slope angle at which the machine will tip is dependent on many factors. Among these are: mowing conditions such as wet or undulating turf, speed (especially in turns), position of the cutting units (with Sidewinder), tire pressure, and operator experience.

At side hill angles of 20 degrees or less, the risk of a rollover is low. As the slope angle increases to a recommended maximum limit of 25 degrees, the risk of a rollover increases to a moderate level. *Do not exceed a 25 degree side hill slope angle because the risk of a rollover and serious injury or death is very high.*

To determine which hills or slopes you may safely operate on, a site survey of the mowing area must be done. When performing this site survey, always use common sense and take into consideration the turf condition and the rollover risk. To determine which hills or slopes may be safely operated on, use the inclinometer provided with each machine. To perform a site survey, lay a 4 ft 2x4 (1.25 meter plank) on the slope surface and measure the angle of the slope. The 2x4 will average the slope but will not take into consideration dips or holes which can cause a sudden change in side hill angle. *The maximum side hill angle should not be greater than 25 degrees.*

Additionally, the machine is equipped with an angle indicator mounted on the steering tube. This indicates the side hill angle the machine is on and identifies the recommended maximum limit of 25 degrees.

*Always wear your seat belt.*

- Start the engine and run it at half idle until it warms up. Push the throttle lever all the way forward, lift the cutting units, disengage the parking brake, press the forward traction pedal, and carefully drive to an open area.
  - Practice moving forward and reverse, and starting and stopping the machine. To stop, take your foot off of the traction pedal and let it return to neutral or press down on the reverse pedal to stop. Going down a hill, you may need to use the reverse pedal to stop.
  - When driving on slopes, drive slowly to maintain steering control and avoid turns to prevent rollovers. In side hill situations you should shift the sidewinder cutting units to the uphill side to give you more stability. Conversely, shifting the cutting units to the down hill side will give you less stability. This should always be done before going on a side hill.
  - When possible, mow up and down hills rather than across them. Have the cutting units lowered when going down a hill to maintain steering control. Do not attempt to turn on a hill.
  - Practice driving around obstacles with the cutting units up and down. Be careful when driving between narrow objects so you do not damage the machine or cutting units.
  - On the Sidewinder unit, get a feel for the reach of the cutting units so you do not hang them up or damage them in any way.
  - Do not shift the units from side to side, unless the cutting units are down and the machine is moving, or the cutting units are up in the transport position. Shifting the cutting units when they are down and the machine is not moving may cause turf damage.
  - Always drive slowly in rough areas.
  - If a person appears in or near the operating area, stop the machine, and do not start it again until the area is cleared. The machine is designed for one person. Never let anyone else ride on the machine with you. This is extremely dangerous and could result in serious injury.
  - Accidents can happen to anyone. The most common causes are excessive speed, sudden turns, terrain (not knowing which slopes and hills can be mowed safely), not stopping the engine before leaving the operator's seat, and drugs which impair your alertness. Cold capsules or prescription drugs may cause drowsiness, as can alcohol and other drugs. Stay alert and stay safe. Failure to do so could result in serious injury.
- Practice operating the machine and become thoroughly familiar with it.

- The Sidewinder offers up to a maximum of 13 inches (33 cm) of overhang, allowing you to trim closer to the edge of sand traps and other obstacles, while at the same time keeping the tractor tires as far away from the edge of traps or water hazards as possible.
- If an obstacle is in the way, shift the cutting units to easily mow around it.
- When transporting the machine from one work area to another, raise the cutting units to the fully up position, move the mow/transport slide to the left to transport, and place the throttle in the Fast position.

## Mowing Techniques

- To begin cutting, engage the cutting units, then approach the mowing area slowly. Once the front cutting units are over the mowing area, lower the cutting units.
- To achieve the professional straight-line cut and striping that is desirable for some applications, find a tree or other object in the distance and drive straight toward it.
- As soon as the front cutting units reach the edge of the mowing area, lift the cutting units and perform a tear drop shaped turn to quickly line you up for your next pass.
- To mow around bunkers, ponds, or other contours easily, use the Sidewinder and move the control lever left or right, depending on your mowing application. The cutting units can also be shifted to vary tire tracking.
- The cutting units tend to throw grass to the left side of the machine. If trimming around bunkers, it is best to mow in a clockwise direction to prevent throwing clippings into the bunker.
- The cutting units can be equipped with bolt-in mulching baffles. The mulching baffles perform well when turf is maintained on a regular schedule to avoid removing more than 1 inch (25 mm) of growth per cutting. When too much growth is cut with the mulching baffles installed, after-cut appearance may deteriorate and the observed power to cut the turf increases. The mulching baffles also perform well for shredding leaves in the fall of the year.

## Mow When Grass is Dry

Mow either in the late morning to avoid the dew, which causes grass clumping, or in late afternoon to avoid the

damage that can be caused by direct sunlight on the sensitive, freshly mowed grass.

## Select the Proper Height-of-Cut Setting to Suit Conditions

Remove approximately one inch or no more than 1/3 of the grass blade when cutting. In exceptionally lush and dense grass you may have to raise your height-of-cut setting another notch.

## Always Start Mowing with Sharp Blades

A sharp blade cuts cleanly and without tearing or shredding the grass blades like a dull blade. Tearing and shredding causes the grass to turn brown at the edges which impairs growth and increases susceptibility to diseases. Make sure blade is in good condition and a full sail is present.

## Check Condition of cutting unit

Make sure cutting chambers are in good condition. Straighten any bends in chamber components to assure correct blade tip/chamber clearance.

## After Mowing

At the completion of mowing operation, thoroughly wash the machine with a garden hose without a nozzle so that excessive water pressure will not cause contamination and damage to the seals and bearings. Make sure that the radiator and oil cooler are kept free of dirt or grass clippings. After cleaning, it is recommended that the machine be inspected for possible hydraulic fluid leaks, damage or wear to the hydraulic and mechanical components, and the cutting unit blades checked for sharpness.

**Important:** After washing the machine, move the Sidewinder mechanism from left to right several times to remove water between the bearing blocks and cross tube.

# Maintenance

**Note:** Determine the left and right sides of the machine from the normal operating position.

## ***Recommended Maintenance Schedule(s)***

<b>Maintenance Service Interval</b>	<b>Maintenance Procedure</b>
After the first hour	<ul style="list-style-type: none"> <li>• Torque the wheel nuts.</li> </ul>
After the first 10 hours	<ul style="list-style-type: none"> <li>• Torque the wheel nuts.</li> <li>• Check the condition and tension of all belts.</li> <li>• Change the hydraulic filter.</li> </ul>
After the first 50 hours	<ul style="list-style-type: none"> <li>• Change the oil and oil filter.</li> </ul>
Before each use or daily	<ul style="list-style-type: none"> <li>• Check the engine oil level.</li> <li>• Check the engine coolant level.</li> <li>• Check the hydraulic fluid level.</li> <li>• Check the tire pressure.</li> <li>• Check the interlock system.</li> <li>• Drain the water separator.</li> <li>• Clean debris off of the radiator and oil cooler.</li> <li>• Check the hydraulic lines and hoses.</li> </ul>
Every 25 hours	<ul style="list-style-type: none"> <li>• Check the electrolyte level. (If machine is in storage, check every 30 days.)</li> </ul>
Every 50 hours	<ul style="list-style-type: none"> <li>• Lubricate all bearings and bushings. (Lubricate all bearings and bushings daily when conditions are dusty and dirty.)</li> </ul>
Every 100 hours	<ul style="list-style-type: none"> <li>• Check the condition and tension of all belts.</li> </ul>
Every 150 hours	<ul style="list-style-type: none"> <li>• Change the oil and oil filter.</li> </ul>
Every 200 hours	<ul style="list-style-type: none"> <li>• Torque the wheel nuts.</li> <li>• Service the Air Cleaner (More frequently in extreme dusty or dirty conditions)</li> <li>• Check the parking brake adjustment.</li> <li>• Change the hydraulic filter.</li> </ul>
Every 400 hours	<ul style="list-style-type: none"> <li>• Check the fuel lines and connections.</li> <li>• Replace the fuel filter canister.</li> <li>• Change the hydraulic fluid.</li> </ul>
Every 500 hours	<ul style="list-style-type: none"> <li>• Grease the bearings in the rear axle.</li> </ul>
Yearly	<ul style="list-style-type: none"> <li>• Apply a liberal coating of grease to the check valve pins.</li> </ul>
Every 2 years	<ul style="list-style-type: none"> <li>• Drain and clean the fuel tank. (</li> </ul>



**If you leave the key in the ignition switch, someone could accidentally start the engine and seriously injure you or other bystanders.**

**Remove the key from the ignition before you do any maintenance.**

# Daily Maintenance Checklist

Duplicate this page for routine use.

Maintenance Check Item	For the week of:						
	Mon.	Tues.	Wed.	Thurs.	Fri.	Sat.	Sun.
Check the safety interlock operation.							
Check the brake operation.							
Check the engine oil level.							
Check the cooling system fluid level.							
Drain the water/fuel separator.							
Check the air filter, dust cup, and burp valve.							
Check for unusual engine noises. <sup>2</sup>							
Check the radiator and screen for debris							
Check for unusual operating noises.							
Check the hydraulic system oil level.							
Check the hydraulic hoses for damage.							
Check for fluid leaks.							
Check the fuel level.							
Check the tire pressure.							
Check the instrument operation.							
Check the height-of-cut adjustment.							
Lubricate all the grease fittings. <sup>2</sup>							
Touch-up any damaged paint.							

<sup>1</sup>Check the glow plug and injector nozzles if starting is hard, there is excess smoke, or rough running is noted.

<sup>2</sup>Immediately **after every** washing, regardless of the interval listed.

**Important:** Refer to your engine *Operator's Manual* for additional maintenance procedures.

## Notation for Areas of Concern

Inspection performed by:		
Item	Date	Information

# Service Interval Chart

## GROUNDMASTER 3500-D

### QUICK REFERENCE AID

**CHECK/SERVICE (DAILY)**

1. OIL LEVEL, ENGINE
2. ENGINE OIL DRAIN (3/4" OR 19mm SOCKET)
3. OIL LEVEL HYDRAULIC TANK
4. COOLANT LEVEL, RADIATOR
5. FUEL/WATER SEPARATOR
6. AIR CLEANER
7. RADIATOR SCREEN
8. PARKING BRAKE
9. TIRE PRESSURE (14-18 psi)
10. BATTERY
11. BELTS (FAN, ALTERNATOR, HYDRAULIC PUMP)

GREASING - SEE OPERATOR'S MANUAL

### FLUID SPECIFICATIONS/CHANGE INTERVALS

SEE OPERATOR'S MANUAL FOR INITIAL CHANGES.	FLUID TYPE	CAPACITY	CHANGE INTERVAL		FILTER PART NO.
			FLUID	FILTER	
A. ENGINE OIL	SAE 15W-40 CH-4	4.0 QTS.*	150 HRS.	150 HRS.	104-5167
B. HYD. CIRCUIT OIL	MOBIL DTE-15M	6 GAL.*	400 HRS.	200 HRS.	86-3010
C. AIR CLEANER				200 HRS.	98-9763
D. FILTER, IN-LINE FUEL				400 HRS.	98-7612
E. WATER SEPARATOR				400 HRS.	98-9764
F. FUEL TANK	NO. 2-DIESEL	11 GALS.	DRAIN AND FLUSH, 2 YRS.		
G. COOLANT	50/50 ETHYLENE GLYCOL/WATER	6 QTS.	DRAIN AND FLUSH, 2 YRS.		

\* INCLUDING FILTER 107-7800

**FUSES**

MAIN <b>15A</b>
MAX <b>15A</b> OPTIONAL LIGHT
SYSTEM <b>10A</b> GAUGES SCM PTO
2A SCM
START <b>10A</b>

Figure 26

## Premaintenance Procedures

### Removing the Hood

The hood may be easily removed to ease maintenance procedures in the engine area of the machine.

1. Unlatch and raise the hood.
2. Remove the hairpin cotter securing the hood pivot to the mounting brackets (Figure 27).

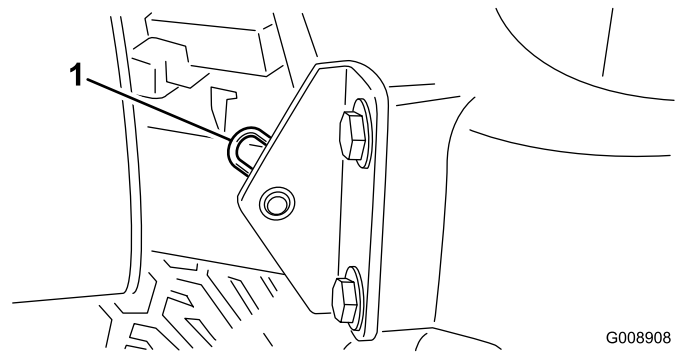


Figure 27

1. Hairpin cotter
3. Slide the hood to the right side, lift the other side, and pull it out of the brackets.

**Note:** Reverse the procedure to install the hood.

# Lubrication

## Greasing the Bearings And Bushings

**Service Interval:** Every 50 hours (Lubricate all bearings and bushings daily when conditions are dusty and dirty.)

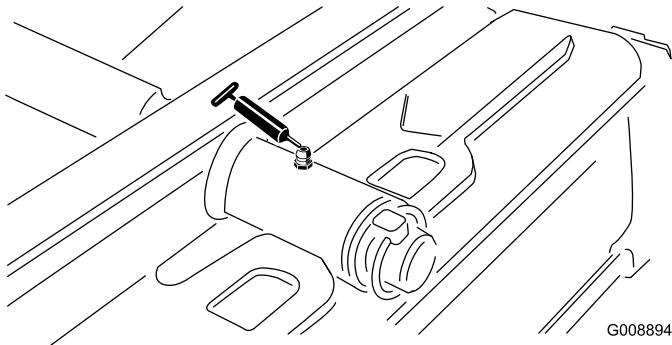
Yearly

Every 500 hours/Yearly (whichever comes first)

The machine has grease fittings that must be lubricated regularly with No. 2 General Purpose Lithium Base Grease. Bearings and bushings must be lubricated daily when operating conditions are extremely dusty and dirty. Dusty and dirty operating conditions could cause dirt to get into the bearings and bushings, resulting in accelerated wear. Lubricate grease fittings immediately after every washing, regardless of interval specified.

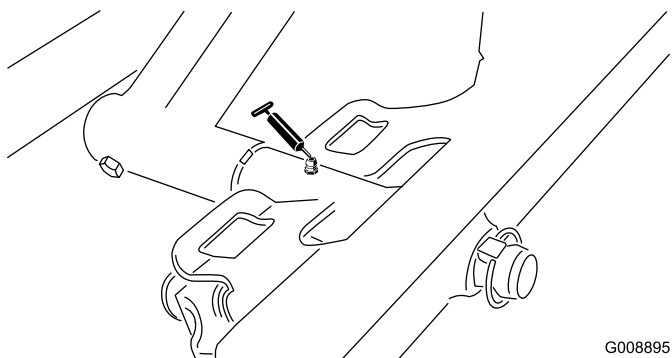
The grease fitting locations and quantities are:

- Rear cutting unit pivot (Figure 28)



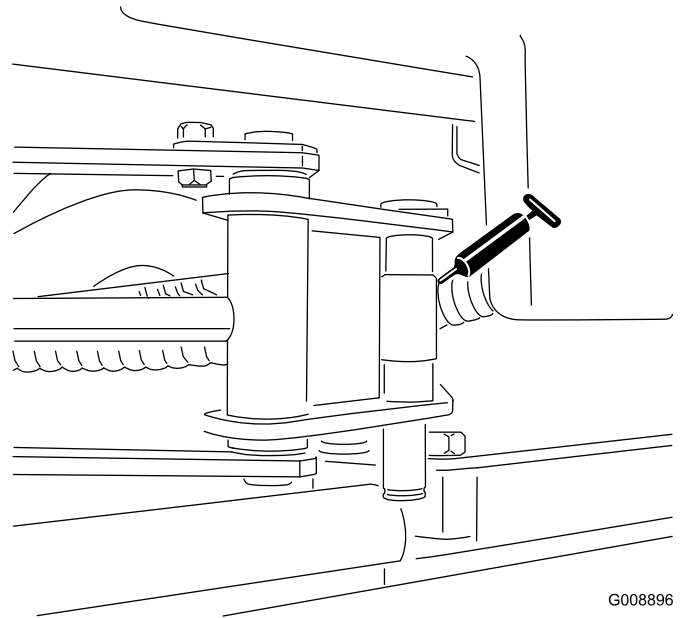
**Figure 28**

- Front cutting unit pivot (Figure 29)



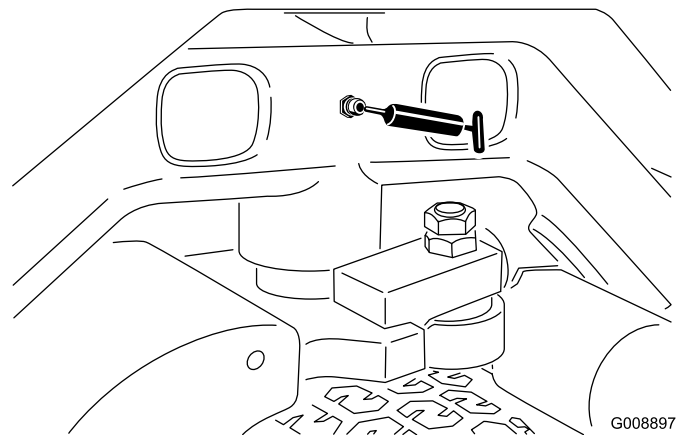
**Figure 29**

- SideWinder cylinder ends (2) (Figure 30)



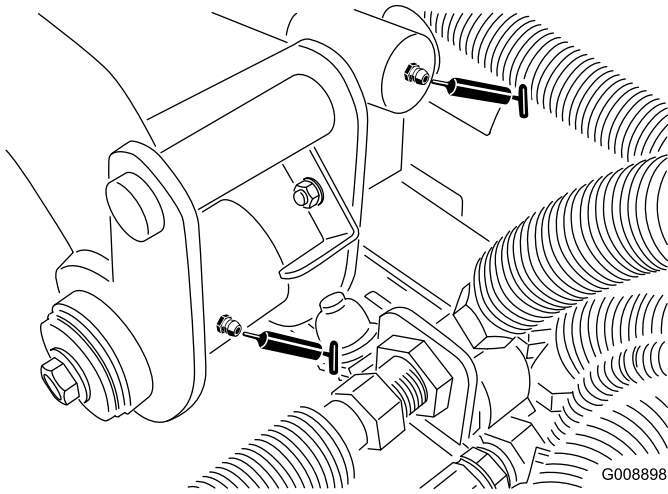
**Figure 30**

- Steering pivot (Figure 31)

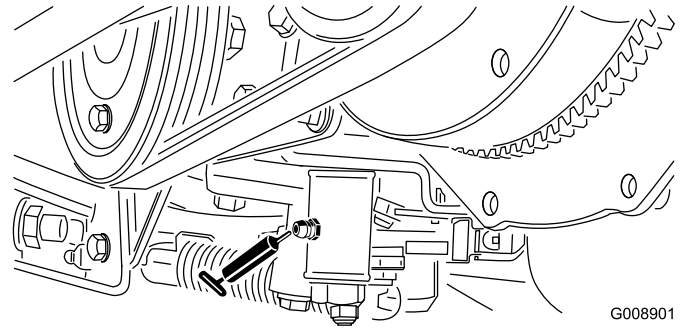


**Figure 31**

- Rear lift arm pivot and lift cylinder (2) (Figure 32)



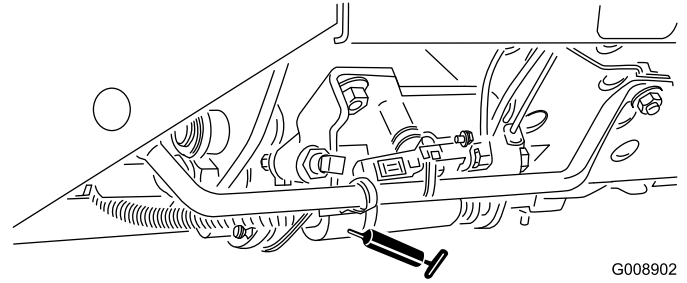
**Figure 32**



**Figure 35**

G008901

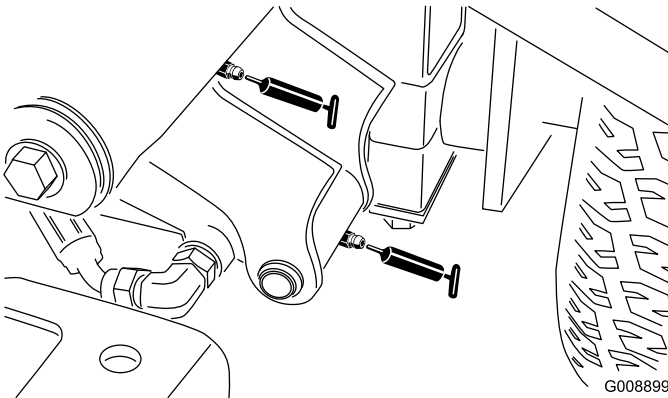
- Mow/transport slide (Figure 36)



**Figure 36**

G008902

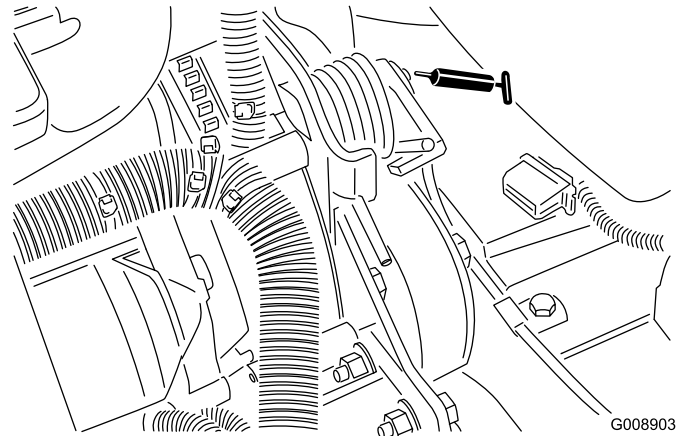
- Left front lift arm pivot and lift cylinder (2) (Figure 33)



**Figure 33**

G008899

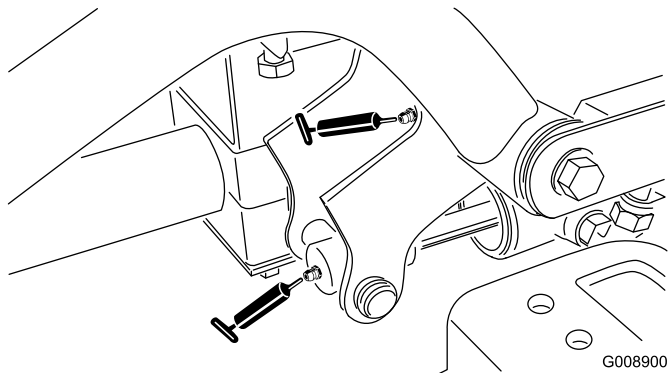
- Belt tension pivot (Figure 37)



**Figure 37**

G008903

- Right front lift arm pivot and lift cylinder (2) (Figure 34)

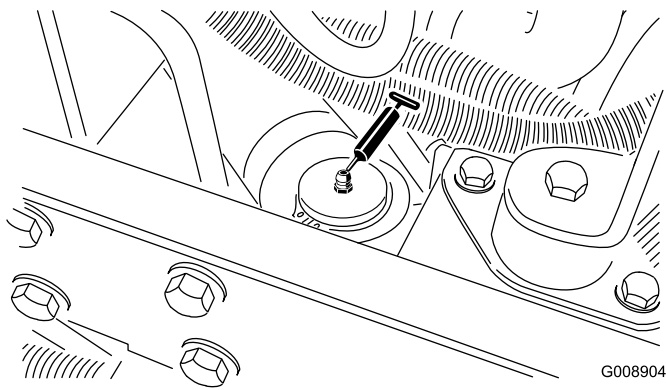


**Figure 34**

G008900

- Steering cylinder (Figure 38).

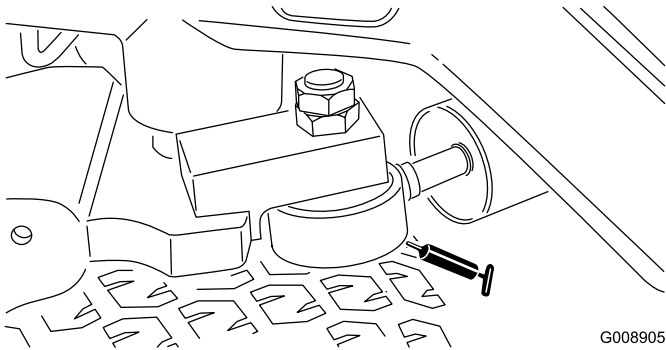
- Neutral adjust mechanism (Figure 35)



**Figure 38**

G008904

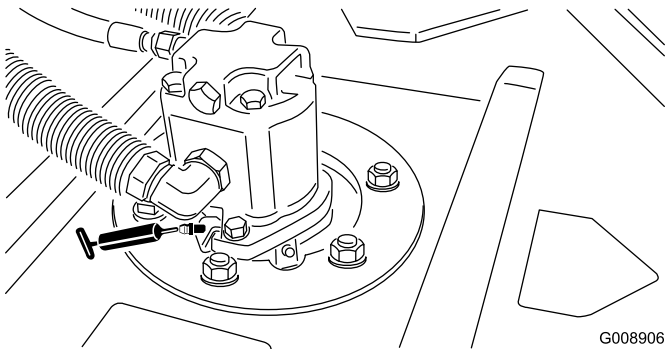
**Note:** If desired, an additional grease fitting may be installed in the other end of the steering cylinder. Remove the tire, install the fitting, grease the fitting, remove the fitting, and install the plug (Figure 39).



**Figure 39**

G008905

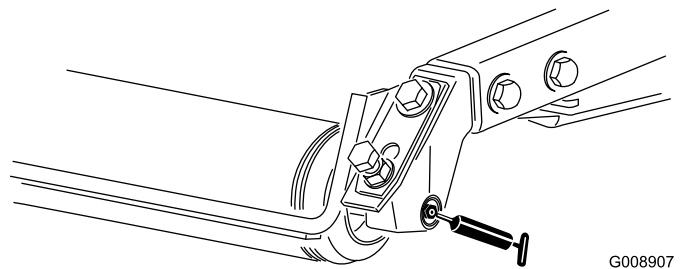
- Cutting unit spindle shaft bearings (1 per cutting unit) (Figure 40)



**Figure 40**

G008906

- Rear roller bearings (2 per cutting unit) (Figure 41)



**Figure 41**

G008907

**Note:** The flush fittings on the rollers (Figure 27) require a grease gun nozzle adapter. Order Toro Part No. 107-1998 from your Authorized Toro Distributor.

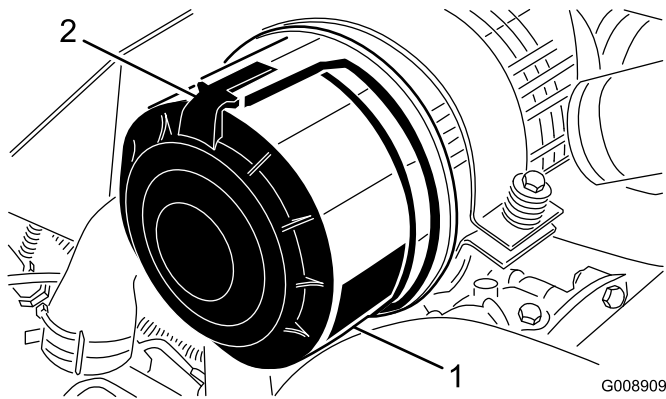
**Important:** Do not lubricate the Sidewinder cross tube. The bearing blocks are self-lubricated.

# Engine Maintenance

## Servicing the Air Cleaner

**Service Interval:** Every 200 hours (More frequently in extreme dusty or dirty conditions)

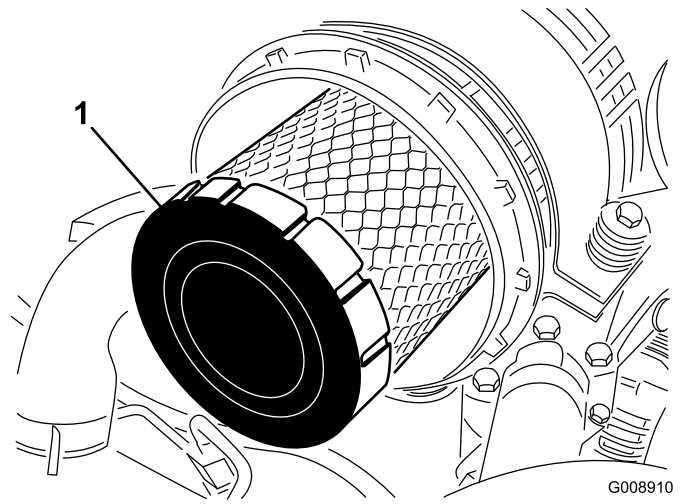
- Check the air cleaner body for damage which could cause an air leak. Replace if damaged. Check the whole intake system for leaks, damage, or loose hose clamps.
  - Service at the recommended service interval or earlier if engine performance suffers due to extremely dusty, dirty conditions. Changing the air filter before it is necessary only increases the chance of dirt entering the engine when the filter is removed.
  - Be sure the cover is seated correctly and seals with the air cleaner body.
1. Release the latches securing the air cleaner cover to the air cleaner body (Figure 42).



**Figure 42**

1. Air cleaner cover
2. Air cleaner latch

2. Remove the cover from the air cleaner body.
3. Before removing the filter, use low pressure air (40 psi, clean and dry) to help remove large accumulations of debris packed between outside of primary filter and the canister. Avoid using high pressure air which could force dirt through the filter into the intake tract. This cleaning process prevents debris from migrating into the intake when the primary filter is removed.
4. Remove and replace the primary filter (Figure 43).  
Cleaning of the used element is not recommended due to the possibility of damage to the filter media.



**Figure 43**

1. Primary filter

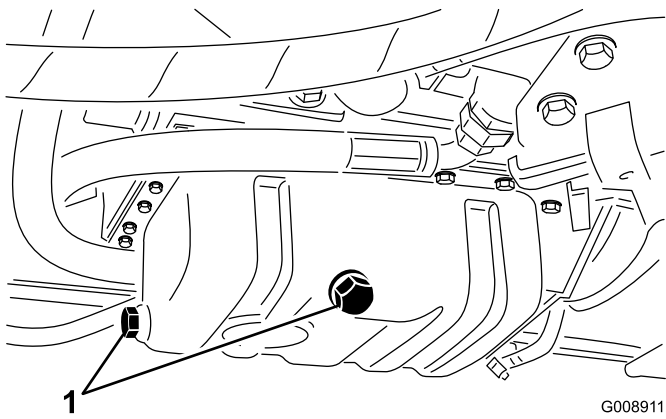
5. Inspect the new filter for shipping damage, checking the sealing end of the filter and the body. **Do not use a damaged element.**
6. Insert the new filter by applying pressure to the outer rim of the element to seat it in the canister. **Do not apply pressure to the flexible center of the filter.**
7. Clean the dirt ejection port located in the removable cover. Remove the rubber outlet valve from the cover, clean the cavity and replace the outlet valve.
8. Install the cover orienting the rubber outlet valve in a downward position—between approximately 5:00 to 7:00 when viewed from the end.
9. Secure the cover latches.

## Changing the Engine Oil and Filter

**Service Interval:** After the first 50 hours

Every 150 hours

1. Remove either drain plug (Figure 44) and let oil flow into a drain pan. When the oil stops flowing, install the drain plug.

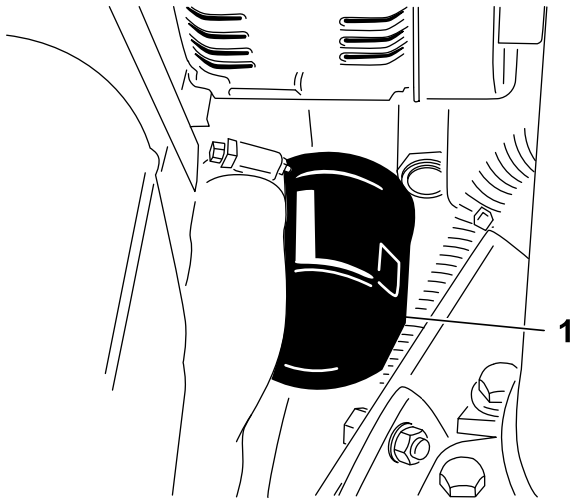


**Figure 44**

G008911

1. Engine oil drain plug

2. Remove the oil filter (Figure 45). Apply a light coat of clean oil to the new filter seal before screwing it on. **Do not overtighten.**



**Figure 45**

G008912

1. Engine oil filter

3. Add oil to the crankcase; refer to Checking the Engine Oil Level.

# Fuel System Maintenance

## Servicing the Fuel Tank

**Service Interval:** Every 2 years—Drain and clean the fuel tank. (

Drain and clean the tank if the fuel system becomes contaminated or if the machine will be stored for an extended period of time. Use clean fuel to flush out the tank.

## Inspecting the Fuel Lines and Connections

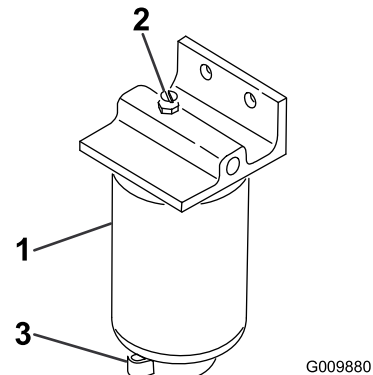
**Service Interval:** Every 400 hours/Yearly (whichever comes first)

Inspect the fuel lines and connections for deterioration, damage, or loose connections.

## Draining the Water Separator

**Service Interval:** Before each use or daily

1. Place a clean container under the fuel filter.
2. Loosen the drain valve on the bottom of the filter canister (Figure 46).



**Figure 46**

G009880

1. Water separator/filter canister
2. Vent plug
3. Drain valve

3. Tighten the valve after draining.

## Changing the Fuel Filter Canister

**Service Interval:** Every 400 hours

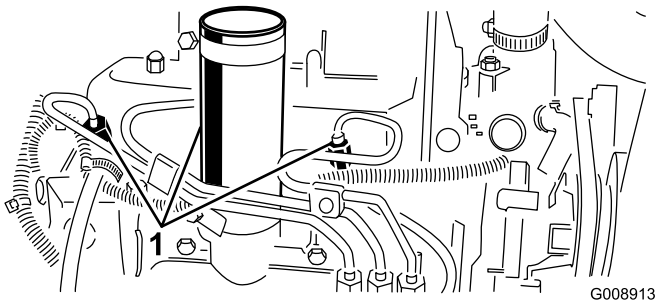
1. Clean the area where the filter canister mounts (Figure 46).

2. Remove the filter canister and clean the mounting surface.
3. Lubricate the gasket on the filter canister with clean oil.
4. Install the filter canister by hand until the gasket contacts the mounting surface; then rotate an additional 1/2 turn.

## Bleeding Air from the Injectors

**Note:** This procedure should be used only if the fuel system has been purged of air through normal priming procedures and the engine will not start; refer to Bleeding the Fuel System.

1. Loosen the pipe connection to the No. 1 nozzle and holder assembly.



**Figure 47**

1. Fuel injectors

2. Move the throttle to the Fast position.
3. Turn the key in the key switch to the Start position and watch the fuel flow around the connector. Turn the key to the Off position when solid flow is observed.
4. Tighten the pipe connector securely.
5. Repeat the procedure on the remaining nozzles.

# Electrical System Maintenance

## Caring for the Battery

**Service Interval:** Every 25 hours—Check the electrolyte level. (If machine is in storage, check every 30 days.)

The battery electrolyte level must be properly maintained and the top of the battery kept clean. If the machine is stored in a location where temperatures are extremely high, the battery will run down more rapidly than if the machine is stored in a location where temperatures are cool.

Maintain the cell level with distilled or demineralized water. Do not fill the cells above the bottom of the split ring inside each cell. Install the filler caps with the vents pointing to the rear (toward the fuel tank).



**Battery electrolyte contains sulfuric acid which is a deadly poison and causes severe burns.**

- Do not drink electrolyte and avoid contact with skin, eyes or clothing. Wear safety glasses to shield your eyes and rubber gloves to protect your hands.
- Fill the battery where clean water is always available for flushing the skin.

Keep the top of the battery clean by washing it periodically with a brush dipped in ammonia or bicarbonate of soda solution. Flush the top surface with water after cleaning. Do not remove the filler caps while cleaning.

The battery cables must be tight on the terminals to provide good electrical contact.



Incorrect battery cable routing could damage the tractor and cables causing sparks. Sparks can cause the battery gasses to explode, resulting in personal injury.

- Always *disconnect* the negative (black) battery cable before disconnecting the positive (red) cable.
- Always *connect* the positive (red) battery cable before connecting the negative (black) cable.

If corrosion occurs at the terminals, disconnect the cables, negative (–) cable first, and scrape the clamps and terminals separately. Reconnect the cables, positive (+) cable first, and coat the terminals with petroleum jelly.

## Warning

### CALIFORNIA Proposition 65 Warning

Battery posts, terminals, and related accessories contain lead and lead compounds, chemicals known to the State of California to cause cancer and reproductive harm.

*Wash hands after handling.*

## Fuses

The fuses in machines electrical system are located under console cover.

# Drive System Maintenance

## Adjusting the Traction Drive for Neutral

If the machine moves when the traction pedal is in the neutral position, the traction cam must be adjusted.

1. Position the throttle lever rearward so it stops against the control panel slot.
2. Loosen the throttle cable connector on the injection pump lever arm (Figure 48).

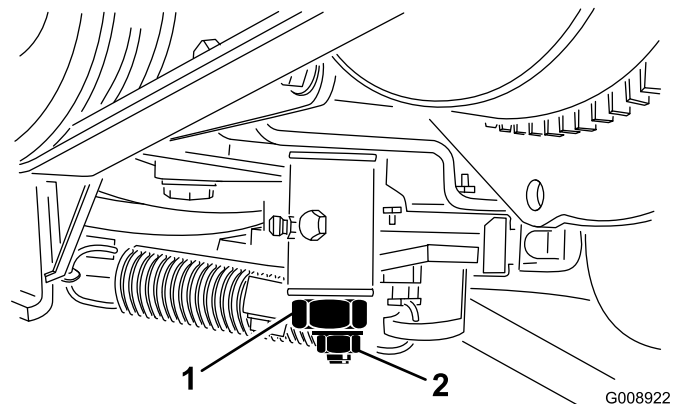


Figure 48

1. Injection pump lever arm
3. Hold the injection pump lever arm against the low idle stop and tighten the cable connector.
4. Loosen the screws securing the throttle control to the control panel.
5. Push the throttle control lever all of the way forward.
6. Slide the stop plate until it contacts the throttle lever and tighten the screws securing the throttle control to the control panel.
7. If the throttle does not stay in position during operation, torque the locknut, used to set the friction device on the throttle lever, to 40 to 55 in-lb (5 to 6 N-m). The maximum force required to operate the throttle lever should be 20 lb (27 N-m).

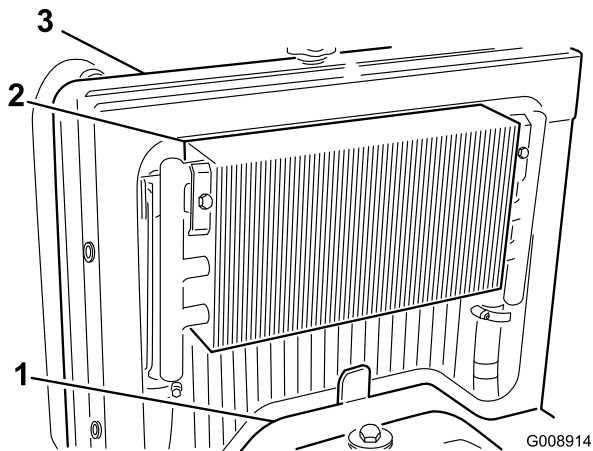
# Cooling System Maintenance

## Cleaning the Engine Cooling System

**Service Interval:** Before each use or daily

Remove debris from the oil cooler and radiator daily. Clean them more frequently in dirty conditions.

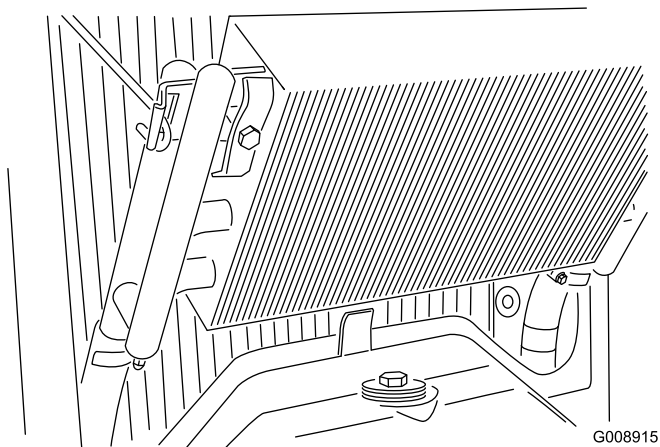
1. Turn the engine off and raise the hood. Clean the engine area thoroughly of all debris.
2. Remove the access panel (Figure 49).



**Figure 49**

1. Access panel
2. Oil cooler
3. Radiator

3. Unlatch the oil cooler and pivot it rearward (Figure 50). Clean both sides of the oil cooler and radiator area thoroughly with water or compressed air. Pivot the oil cooler back into position.



**Figure 50**

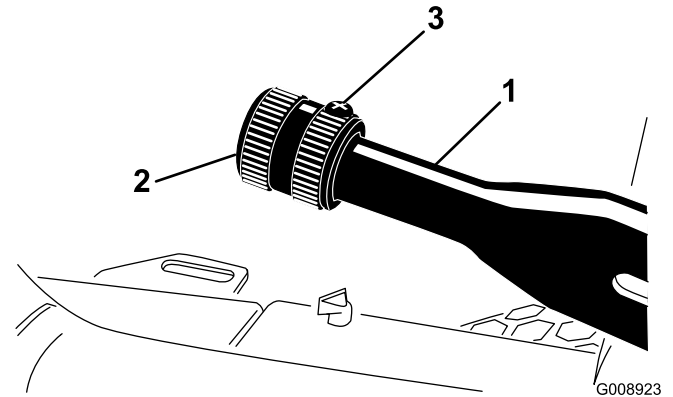
4. Install the access panel and close the hood.

# Brake Maintenance

## Adjusting the Parking Brake

**Service Interval:** Every 200 hours—Check the parking brake adjustment.

1. Loosen the set screw securing the knob to the parking brake lever (Figure 51).



**Figure 51**

1. Parking brake lever
2. Knob
3. Set screw

2. Rotate the knob until a force of 30–40 lb (41–68 N-m) is required to actuate the lever.
3. Tighten the set screw after the adjustment has been attained.

# Belt Maintenance

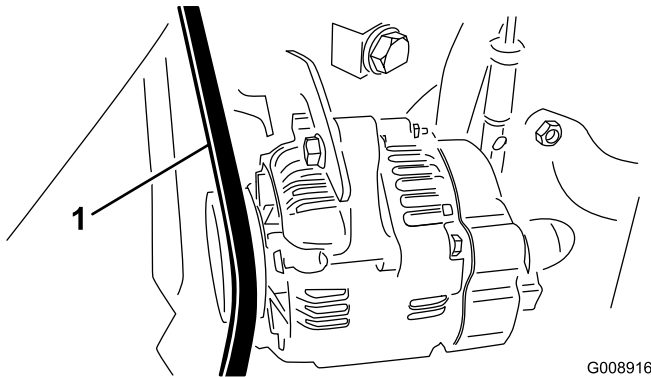
## Servicing the Engine Belts

**Service Interval:** After the first 10 hours—Check the condition and tension of all belts.

Every 100 hours—Check the condition and tension of all belts.

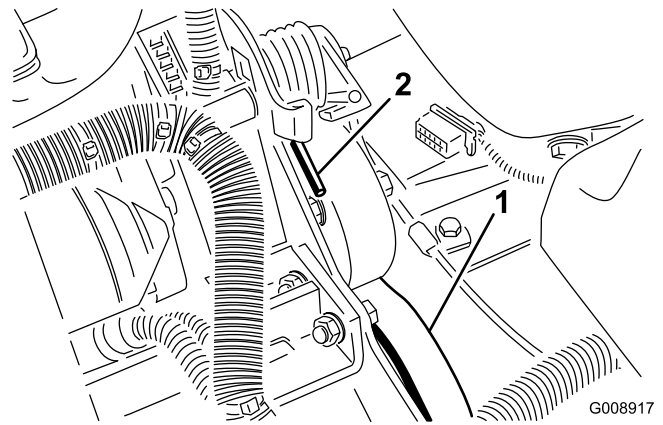
### Tensioning the Alternator/Fan Belt

1. Open the hood.
2. Check the tension by depressing the belt midway between the alternator and crankshaft pulleys with 22 lb (30 N-m) of force. The belt should deflect 7/16 inch (11 mm).



**Figure 52**

1. Alternator/fan belt



**Figure 53**

1. Hydrostat drive belt
2. Spring end

3. Replace the belt.
4. Reverse the procedure to tension the spring.

3. If the deflection is incorrect, complete the following procedure to tension the belt:
  - A. Loosen the bolt securing the brace to the engine and the bolt securing the alternator to the brace.
  - B. Insert a pry bar between the alternator and engine and pry out on the alternator.
  - C. When the proper tension is achieved, tighten the alternator and brace bolts to secure the adjustment.

### Replacing the Hydrostat Drive Belt

1. Insert a nut driver or small piece of tubing onto the end of the belt tensioning spring.



**Use caution when de-tensioning the spring, as it is under a heavy load.**

2. Push down and forward on the spring end (Figure 53) to unhook it from the bracket and release tension on the spring.

# Controls System Maintenance

## Adjusting the Throttle

1. Position the throttle lever rearward so it stops against the control panel slot.
2. Loosen the throttle cable connector on the injection pump lever arm (Figure 54).

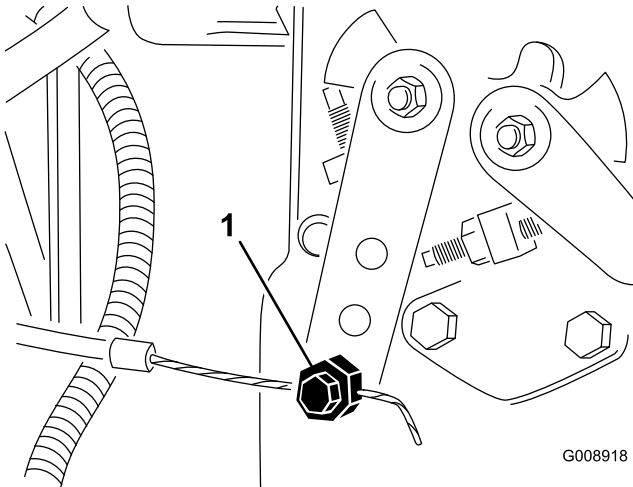


Figure 54

1. Injection pump lever arm

3. Hold the injection pump lever arm against the low idle stop and tighten the cable connector.
4. Loosen the screws securing the throttle control to the control panel.
5. Push the throttle control lever all of the way forward.
6. Slide the stop plate until it contacts the throttle lever and tighten the screws securing the throttle control to the control panel.
7. If the throttle does not stay in position during operation, torque the locknut, used to set the friction device on the throttle lever, to 40–55 inch-lb (5–6 N-m). The maximum force required to operate the throttle lever should be 20 lb (27 N-m).

# Hydraulic System Maintenance

## Changing the Hydraulic Filter

**Service Interval:** After the first 10 hours

Every 200 hours/Yearly (whichever comes first)

Use a genuine Toro replacement filter, Part No. 86-3010.

**Important:** Use of any other filter may void the warranty on some components.

1. Position the machine on a level surface, lower the cutting units, stop the engine, engage the parking brake, and remove the key from the ignition switch.
2. Pinch off the hose to the filter mounting plate.
3. Clean around the filter mounting area. Place a drain pan under the filter (Figure 55) and remove the filter.

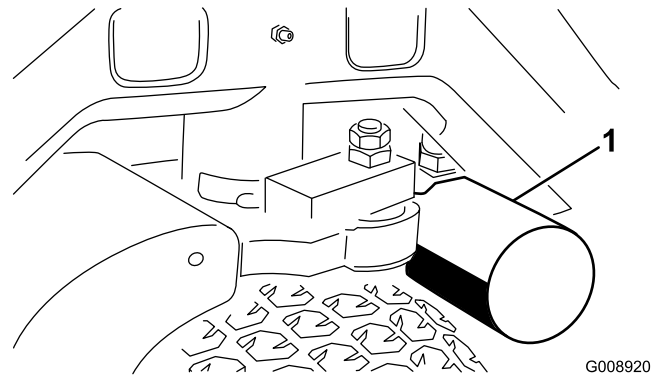


Figure 55

1. Hydraulic filter

4. Lubricate the new filter gasket and fill the filter with hydraulic fluid.
5. Ensure that the filter mounting area is clean. Screw the filter on until the gasket contacts the mounting plate; then tighten the filter 1/2 turn.
6. Release the hose to the filter mounting plate.
7. Start the engine and let it run for about two minutes to purge air from the system. Stop the engine and check for leaks.

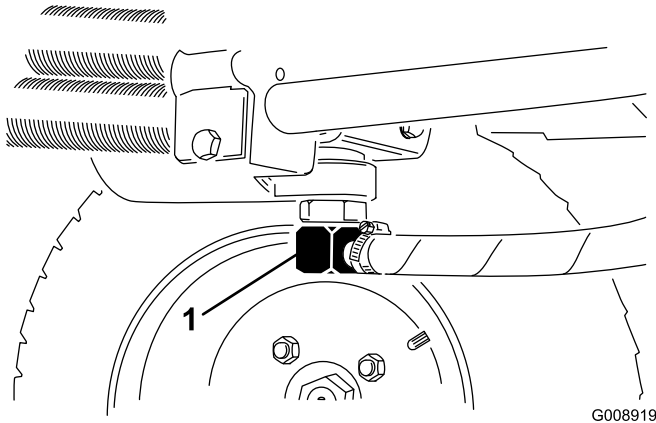
## Changing the Hydraulic Fluid

**Service Interval:** Every 400 hours

If the fluid becomes contaminated, contact your local Toro distributor because the system must be flushed. Contaminated fluid looks milky or black when compared to clean oil.

1. Turn the engine off and raise the hood.

2. Disconnect the hydraulic line (Figure 56) or remove the hydraulic filter (Figure 55) and let the hydraulic fluid flow into a drain pan. Install the hydraulic line when hydraulic fluid stops draining.

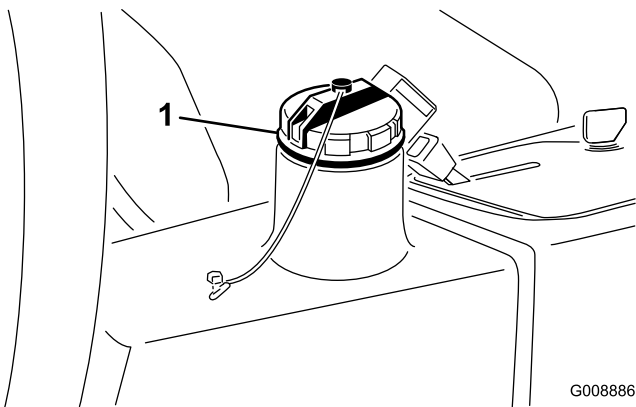


**Figure 56**

1. Hydraulic line

3. Fill the reservoir (Figure 57) with approximately 3.5 U.S. gallons (13.2 l) of hydraulic fluid; refer to Checking the Hydraulic System.

**Important:** Use only the hydraulic fluids specified. Other fluids could cause system damage.



**Figure 57**

1. Hydraulic fill cap

4. Install the reservoir cap. Start the engine and use all of the hydraulic controls to distribute the hydraulic fluid throughout the system. Also check for leaks; then stop the engine.
5. Check the fluid level and add enough to raise the level to Full mark on the dipstick. **Do not overfill.**

## Checking the Hydraulic Lines and Hoses

**Service Interval:** Before each use or daily

Check hydraulic lines and hoses for leaks, kinked lines, loose mounting supports, wear, loose fittings, weather deterioration, and chemical deterioration. Make all necessary repairs before operating.



**Hydraulic fluid escaping under pressure can penetrate skin and cause injury.**

- Make sure all hydraulic fluid hoses and lines are in good condition and all hydraulic connections and fittings are tight before applying pressure to the hydraulic system.
- Keep your body and hands away from pin hole leaks or nozzles that eject high pressure hydraulic fluid.
- Use cardboard or paper to find hydraulic leaks.
- Safely relieve all pressure in the hydraulic system before performing any work on the hydraulic system.
- Seek immediate medical attention if fluid is injected into skin.

# Storage

## Storing the Battery

If the machine will be stored more than 30 days, remove the battery and charge it fully. Store the battery in a cool atmosphere to avoid quick deterioration of the charge in the battery. To prevent the battery from freezing, make sure it is fully charged. The specific gravity of a fully charged battery is 1.265–1.299.

## Preparation for Seasonal Storage

Follow these procedures anytime you will be storing the machine for more than 30 days.

### Traction Unit

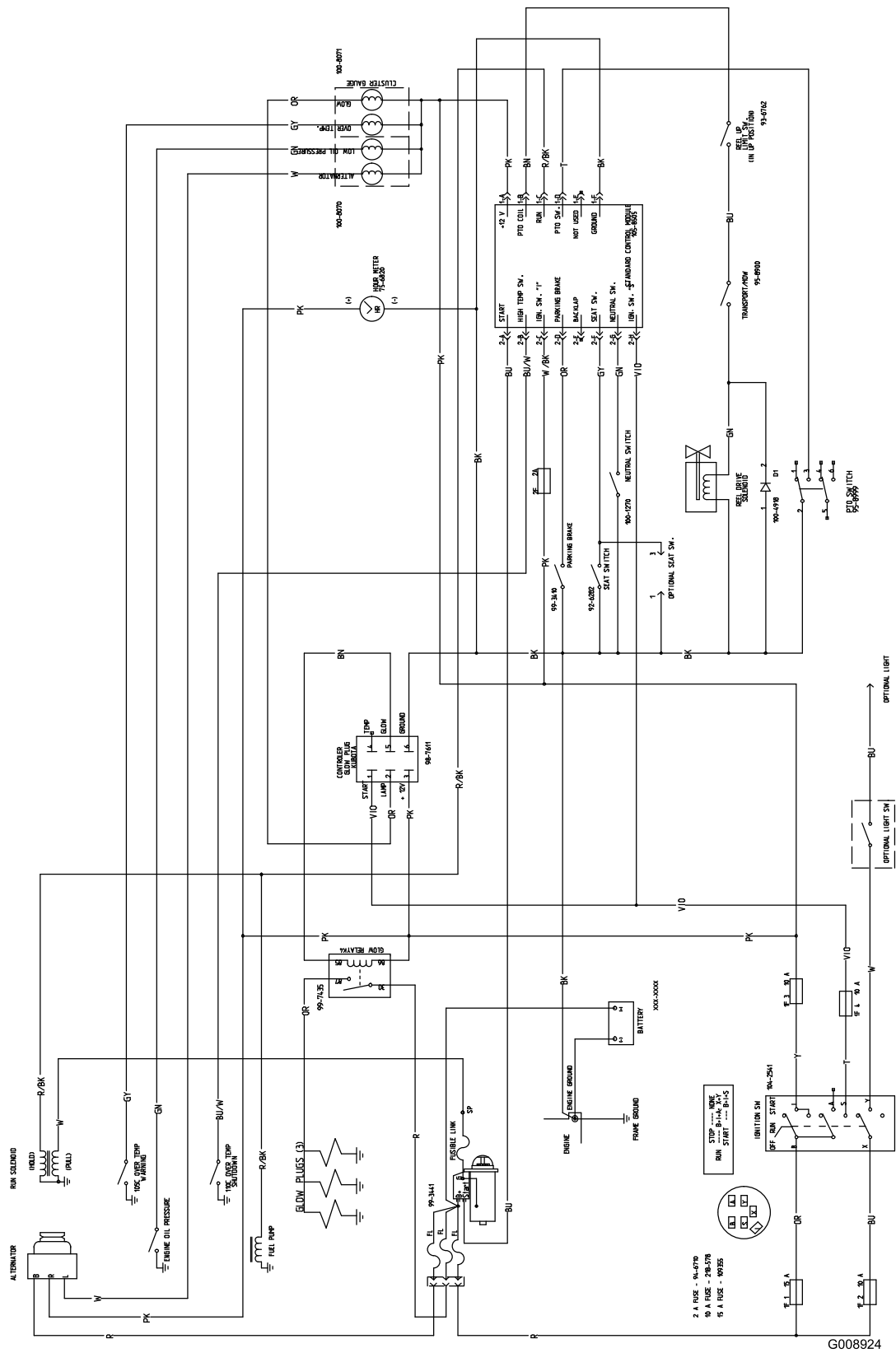
1. Thoroughly clean the traction unit, cutting units, and engine.
2. Check the tire pressure. Inflate all tires to 14 to 18 psi (97 to 110 kPa).
3. Check all fasteners for looseness; tighten as necessary.
4. Grease or oil all grease fittings and pivot points. Wipe up any excess lubricant.
5. Lightly sand and use touch-up paint on painted areas that are scratched, chipped, or rusted. Repair any dents in the metal body.
6. Service the battery and cables as follows:
  - A. Remove the battery terminals from the battery posts.
  - B. Remove the battery.
  - C. Slowly recharge the battery before storage and every 60 days thereafter for 24 hours to prevent lead sulfation of the battery.

To prevent the battery from freezing, make sure it is fully charged. The specific gravity of a fully charged battery is 1.265–1.299.
  - D. Clean the battery, terminals, and posts with a wire brush and baking soda solution.
  - E. Coat the cable terminals and battery posts with Grafo 112X skin-over grease (Toro Part No. 505-47) or petroleum jelly to prevent corrosion.
  - F. Either store it on the shelf or on the machine in a cool area. Leave the cables disconnected if it is stored on the machine.

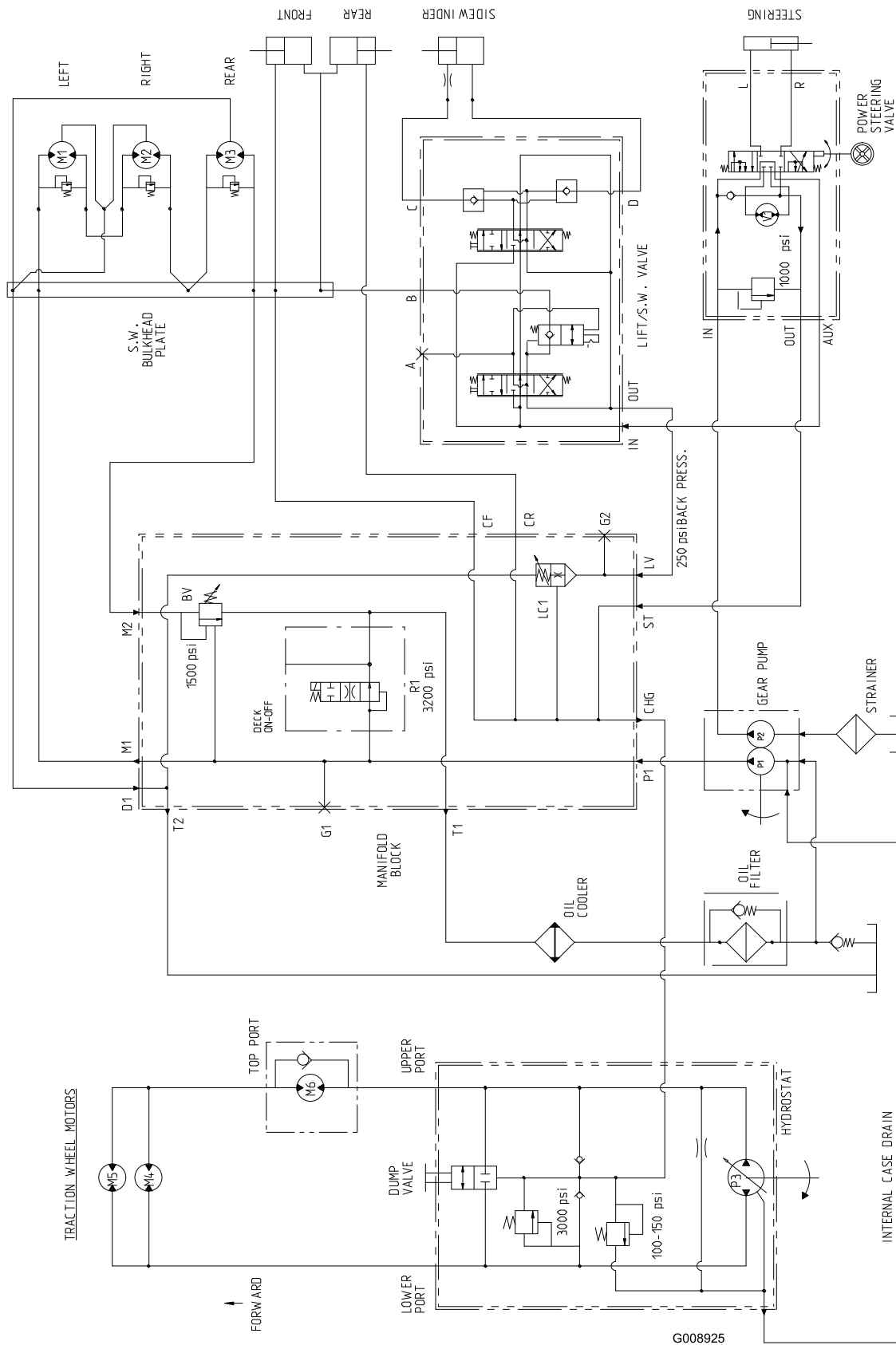
### Engine

1. Drain the engine oil from the oil pan and replace the drain plug.
2. Remove and discard the oil filter. Install a new oil filter.
3. Refill the oil pan with approximately 4 qt (3.8 l) of SAE15W-40 motor oil.
4. Start the engine and run it at idle speed for approximately two minutes.
5. Stop the engine.
6. Thoroughly drain all fuel from the fuel tank, fuel lines, fuel filter, and water separator assembly.
7. Flush the fuel tank with fresh, clean diesel fuel.
8. Secure all fuel system fittings.
9. Thoroughly clean and service the air cleaner assembly.
10. Seal the air cleaner inlet and the exhaust outlet with weatherproof tape.
11. Check anti-freeze protection and add as needed for expected minimum temperature in your area.

# Schematics



Electrical Schematic (Rev. A)



Hydraulic Schematic (Rev. A)

# Notes:

# Notes:



## Toro General Commercial Products Warranty

### A Two-Year Limited Warranty

#### Conditions and Products Covered

The Toro Company and its affiliate, Toro Warranty Company, pursuant to an agreement between them, jointly warrant your Toro Commercial Product ("Product") to be free from defects in materials or workmanship for two years or 1500 operational hours\*, whichever occurs first. This warranty is applicable to all products with the exception of Aerators (refer to separate warranty statements for these products). Where a warrantable condition exists, we will repair the Product at no cost to you including diagnosis, labor, parts, and transportation. This warranty begins on the date the Product is delivered to the original retail purchaser.

\* Product equipped with hour meter

#### Instructions for Obtaining Warranty Service

You are responsible for notifying the Commercial Products Distributor or Authorized Commercial Products Dealer from whom you purchased the Product as soon as you believe a warrantable condition exists. If you need help locating a Commercial Products Distributor or Authorized Dealer, or if you have questions regarding your warranty rights or responsibilities, you may contact us at:

Toro Commercial Products Service Department  
Toro Warranty Company  
8111 Lyndale Avenue South  
Bloomington, MN 55420-1196  
952-888-8801  
E-mail: commercial.warranty@toro.com

#### Owner Responsibilities

As the Product owner, you are responsible for required maintenance and adjustments stated in your *Operator's Manual*. Failure to perform required maintenance and adjustments can be grounds for disallowing a warranty claim.

#### Items and Conditions Not Covered

Not all product failures or malfunctions that occur during the warranty period are defects in materials or workmanship. This warranty does not cover the following:

- Product failures which result from the use of non-Toro replacement parts, or from installation and use of add-on, or modified non-Toro branded accessories and products. A separate warranty may be provided by the manufacturer of these items.
- Product failures which result from failure to perform recommended maintenance and/or adjustments. Failure to properly maintain your Toro product per the Recommended Maintenance listed in the *Operator's Manual* can result in claims for warranty being denied.
- Product failures which result from operating the Product in an abusive, negligent or reckless manner.
- Parts subject to consumption through use unless found to be defective. Examples of parts which are consumed, or used up, during normal Product operation include, but are not limited to, brakes pads and linings, clutch linings, blades, reels, bed knives, tines, spark plugs, castor wheels, tires, filters, belts, and certain sprayer components such as diaphragms, nozzles, and check valves, etc.
- Failures caused by outside influence. Items considered to be outside influence include, but are not limited to, weather, storage practices, contamination, use of unapproved coolants,

lubricants, additives, fertilizers, water, or chemicals, etc.

- Normal noise, vibration, wear and tear, and deterioration.
- Normal "wear and tear" includes, but is not limited to, damage to seats due to wear or abrasion, worn painted surfaces, scratched decals or windows, etc.

#### Parts

Parts scheduled for replacement as required maintenance are warranted for the period of time up to the scheduled replacement time for that part. Parts replaced under this warranty are covered for the duration of the original product warranty and become the property of Toro. Toro will make the final decision whether to repair any existing part or assembly or replace it. Toro may use remanufactured parts for warranty repairs.

#### Note Regarding Deep Cycle Battery Warranty:

Deep cycle batteries have a specified total number of kilowatt-hours they can deliver during their lifetime. Operating, recharging, and maintenance techniques can extend or reduce total battery life. As the batteries in this product are consumed, the amount of useful work between charging intervals will slowly decrease until the battery is completely worn out. Replacement of worn out batteries, due to normal consumption, is the responsibility of the product owner. Battery replacement may be required during the normal product warranty period at owner's expense.

#### Maintenance is at Owner's Expense

Engine tune-up, lubrication cleaning and polishing, replacement of filters, coolant, and completing Recommended Maintenance are some of the normal services Toro products require that are at the owner's expense.

#### General Conditions

Repair by an Authorized Toro Distributor or Dealer is your sole remedy under this warranty.

**Neither The Toro Company nor Toro Warranty Company is liable for indirect, incidental or consequential damages in connection with the use of the Toro Products covered by this warranty, including any cost or expense of providing substitute equipment or service during reasonable periods of malfunction or non-use pending completion of repairs under this warranty. Except for the Emissions warranty referenced below, if applicable, there is no other express warranty. All implied warranties of merchantability and fitness for use are limited to the duration of this express warranty.**

Some states do not allow exclusions of incidental or consequential damages, or limitations on how long an implied warranty lasts, so the above exclusions and limitations may not apply to you. This warranty gives you specific legal rights, and you may also have other rights which vary from state to state.

#### Note regarding engine warranty:

The Emissions Control System on your Product may be covered by a separate warranty meeting requirements established by the U.S. Environmental Protection Agency (EPA) and/or the California Air Resources Board (CARB). The hour limitations set forth above do not apply to the Emissions Control System Warranty. Refer to the Engine Emission Control Warranty Statement printed in your *Operator's Manual* or contained in the engine manufacturer's documentation for details.

#### Countries Other than the United States or Canada

Customers who have purchased Toro products exported from the United States or Canada should contact their Toro Distributor (Dealer) to obtain guarantee policies for your country, province, or state. If for any reason you are dissatisfied with your Distributor's service or have difficulty obtaining guarantee information, contact the Toro importer.