



## 21in Commercial Lawn Mower

Model No. 22156 - 290000001 and up.

### Parts Catalog

---

#### **Ordering Replacement Parts**

To order replacement parts, please supply the part number, the quantity, and the description of each part desired.

#### **Understanding Reference Numbers**

Each identified part in an illustration has a reference number. The reference number for a part also appears in the parts list, along with other information about the part.

This catalog uses two special reference number formats, one to indicate parts in a service assembly and another to indicate the quantity of a given part in an illustration.

#### **Service Assembly Reference Numbers**

Parts in service assemblies have reference numbers in the form a:b. The a represents the reference number of the entire service assembly and the b represents a sequential number unique to each part within the service assembly.

For example, a wheel assembly might be identified by reference number 6, the tire by 6:1, the valve by 6:2, and the wheel by 6:3. When you order the assembly identified by reference number 6, you receive all parts identified by reference numbers 6:1, 6:2, and 6:3. However, you may also order any part individually. Reference numbers of this type appear in illustrations and in part lists.

#### **Reference Numbers Indicating Quantity**

In an illustration, if a reference number indicates more than one part, the reference number has the form nX y. The n represents the quantity of the part, the X is the multiplication symbol, and the y represents the reference number.

For example, in an illustration, the reference number 2X 37 means that two of the parts identified by reference number 37 are indicated.

# Contents

Description	Page	Description	Page
Front End and Tunnel Assembly	..... 3	Camshaft Pulley Assembly Honda GSV190LA A3T	..... 14
Wheel Assembly No. 117-5252	..... 4	Recoil Starter Assembly Honda GSV190LA A3T	..... 15
Discharge Door and Rear Wheel Assembly	..... 5	Fan Cover Assembly Honda GSV190LA A3T	..... 16
Wheel Assembly No. 117-5253	..... 6	Carburetor Assembly Honda GSV190LA A3T	..... 17
Engine and Blade Assembly	..... 7	Air Cleaner Assembly Honda GSV190LA A3T	..... 18
Handle Assembly	..... 8	Muffler Assembly Honda GSV190LA A3T	..... 19
Rear Bag Assembly	..... 9	Fuel Tank Assembly Honda GSV190LA A3T	..... 20
Cylinder Barrel Assembly Honda GSV190LA A3T	..... 10	Flywheel Assembly Honda GSV190LA A3T	..... 21
Oil Pan Assembly Honda GSV190LA A3T	..... 11	Control Assembly Honda GSV190LA A3T	..... 22
Crankshaft Assembly Honda GSV190LA A3T	..... 12	Label Assembly Honda GSV190LA A3T	..... 23
Piston and Connecting Rod Assembly Honda GSV190LA A3T	..... 13		

## Part Description Abbreviations

Part descriptions in this catalog may include the following abbreviations.

AR. .... as required	HYD. .... hydraulic
ASM. .... assembly	LH. .... left hand
BBC. .... blade brake clutch	NI. .... nylon insert
CARR. .... carriage	NPTF. .... national pipe thread fine
DEG. .... degrees	PFH. .... phillips flat head
EXT. .... external	PPH. .... phillips pan head
FH. .... flat head	PPHTF. .... phillips pan head thread forming
GA. .... gauge	PRH. .... phillips round head
HD. .... heavy-duty	PTH. .... phillips truss head
HF. .... hex flange	PTO. .... power-take-off
HH. .... hex head	RH. .... right hand
HHF. .... hex head flange	ROPS. .... roll-over protection system
HHFTF. .... hex head flange thread forming	SFH. .... slotted fillister head
HJ. .... hex jam	SHH. .... slotted hex head
HLH. .... hex lag head	SHWH. .... slotted hex washer head
HOC. .... height-of-cut	SPH. .... slotted pan head
HSBH. .... hex socket button head	SQH. .... square head
HSFH. .... hex socket flat head	SRH. .... slotted round head
HSH. .... hex socket head	STD. .... standard
HWH. .... hex washer head	TAP. .... self tapping
HWHTF. .... hex washer head thread forming	TTH. .... torx truss head

## Footnotes

❶ Not serviced separately

❷ Obtain from your local Honda dealer

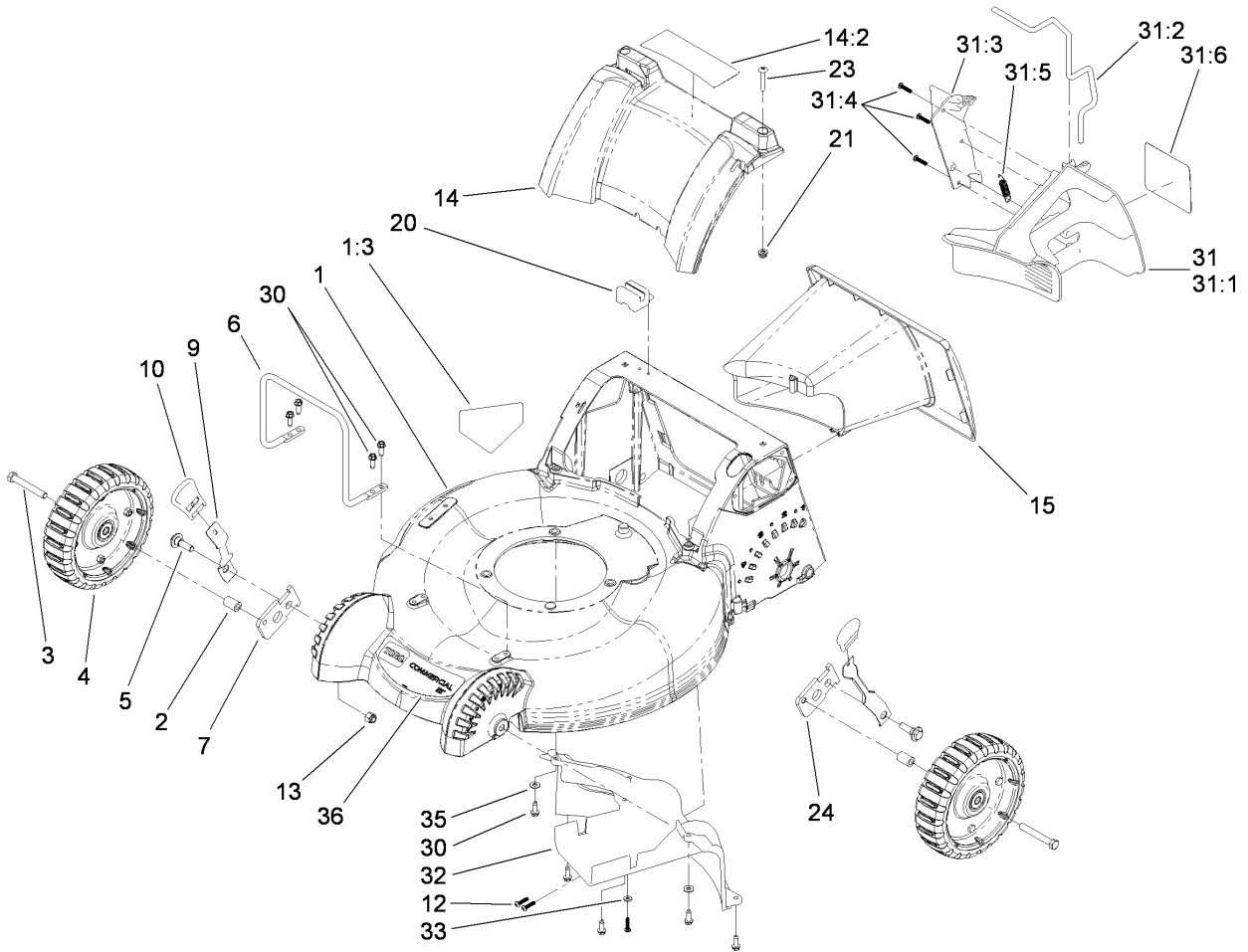

## Front End and Tunnel Assembly

Ref	Part No.	Qty.	Description
1	117-5266	1	Housing Assembly
1:3	94-8072	1	Decal-Danger
2	114-2754	2	Spacer
3	323-13	2	Screw-HH
4	117-5252	2	8 Inch Wheel ASM
5	614672	2	Bolt-Shoulder
6	110-9475-03	1	Guard-Engine
7	110-9421	1	Arm-Pivot, RH
9	110-9434	2	Arm-Spring, Front
10	110-0549	2	Knob-HOC
12	108-7476	6	Screw-Plastite
13	3296-39	2	Nut-Lock, NI
14	115-3177	1	Cover-Rear
14:2	114-2820	1	Decal-Warning
15	110-9455	1	Tunnel
20	110-1786	1	Module-Switch
21	94-1610	2	Nut-Clip
23	108-0965	2	Screw-PTH
24	110-9420	1	Arm-Pivot, LH
30	49-2040	9	Screw-HWHTF
31	110-9468	1	Mulch Plug ASM
31:1	110-9446	1	Plug-Mulch, LH
31:2	110-9448	1	Latch-Plug, Mulch
31:3	110-9447	1	Plug-Mulch, RH

Ref	Part No.	Qty.	Description
31:4	108-7476	3	Screw-Plastite
31:5	110-9458	1	Spring-Extension
31:6	110-9457	1	Decal-Plug, Mulch
32	110-9413	1	Baffle-Rear
33	3256-14	1	Washer-Flat
35	3256-22	2	Washer-Flat
36	117-5247	1	Decal-Housing, Front



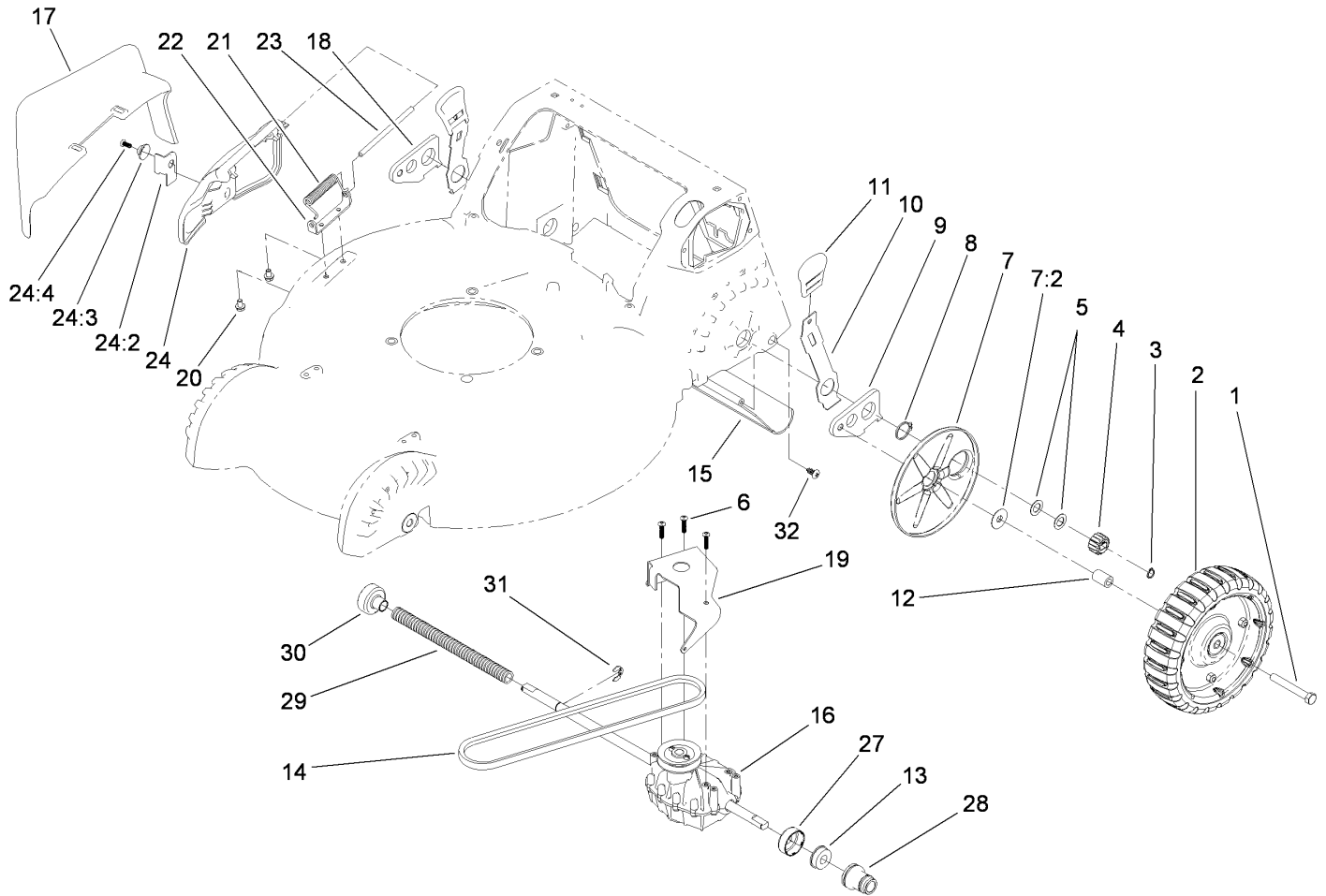

## Discharge Door and Rear Wheel Assembly

Ref	Part No.	Qty.	Description
1	323-13	2	Screw-HH
2	117-5253	2	8-Inch Wheel ASM
3	32151-61	2	Ring-Retaining
4	110-9417	2	Pinion
5	36-4780	2	Washer-Plain
6	108-7476	3	Screw-Plastite
7	110-1792	2	Wheel Cover ASM
7:2	614426	1	Washer-Stepped
8	32151-36	2	Ring-Retaining
9	108-9344	1	Arm-Rear Pivot, LH
10	110-9445	2	Arm-Spring, Rear
11	110-0549	2	Knob-HOC
12	114-2754	2	Spacer
13	104-8699	2	Bearing-Ball
14	110-9429	1	V-Belt
15	112-8768	1	Shield-Trailing
16	114-2819	1	Transmission
17	105-3028	1	Chute-Discharge, Side
18	108-9343	1	Arm-Rear Pivot, RH
19	114-7977-03	1	Bracket-Transmission
20	99-8445	2	Screw-HWH
21	99-5293	1	Spring-Torsion
22	112-6416	1	Bracket-Cover
23	99-5291	1	Rod-Cover

Ref	Part No.	Qty.	Description
24	106-8376	1	Discharge Door ASM
24:2	107-0795	1	Latch-Door
24:3	107-7456	1	Cap-Door
24:4	107-7461	1	Screw-Plastite
27	117-5268	1	Cover-Bearing
28	110-9422	2	Retainer-Bearing
29	117-5260	1	Cover-Shaft, Drive
30	114-2755	1	Cap-Bearing
31	65-2720	1	Ring-Clip, Locking
32	117-1092	2	Screw-PTH



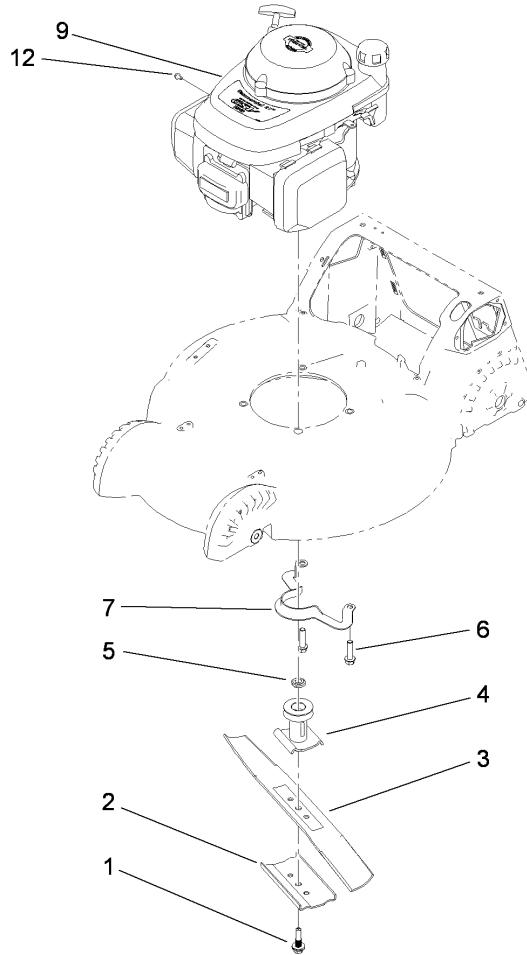

## Engine and Blade Assembly

Ref	Part No.	Qty.	Description				
1	117-5270	1	Bolt-Blade				
2	108-3766-03	1	Support-Blade				
3	108-3759-03	1	Blade-Bagging				
4	114-2774	1	Driver-Blade				
5	106-3999	1	Spacer-Driver				
6	32144-102	3	Screw-HWH				
7	108-8110-03	1	Guide-Belt				
9		1	Engine-Honda, Gsv190La A3T				
12	98-1394	1	Screw-HWH				

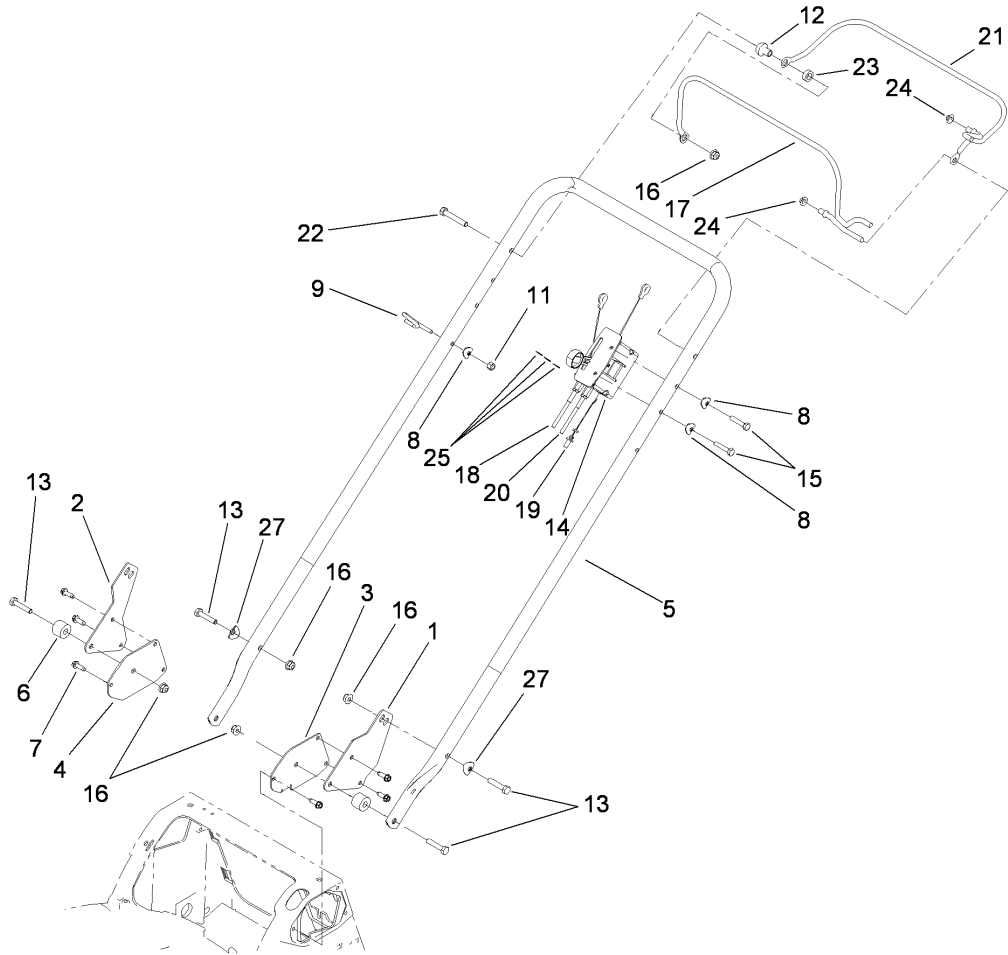

## Handle Assembly

Ref	Part No.	Qty.	Description
1	110-9494-03	1	Support-Strut, LH
2	110-9495-03	1	Support-Strut, RH
3	114-2760-03	1	Plate-Handle, Traction
4	110-9471-03	1	Plate-Handle
5	107-4162-03	1	Handle
6	112-8797-03	2	Spacer
7	49-2040	6	Screw-HWHTF
8	3-7501	3	Washer
9	114-2775	1	Guide-Rope
11	3296-42	1	Nut-Lock, NI
12	49-1630	1	Spacer-Support
13	322-7	4	Screw-HH
14	108-2645	1	Control-Head, Throttle
15	321-13	2	Screw-HH
16	104-8300	5	Nut-Flange, NI
17	114-2768-03	1	Bail-Brake
18	114-2771	1	Cable-Brake
19	110-4923	1	Throttle Cable ASM
20	115-3170	1	Cable-Traction
21	114-2769-03	1	Bail-Traction
22	322-10	1	Screw-HH
23	256-276	1	Spacer-Nylon
24	109-0917	2	Nut-Push
25	32151-86	3	E-Ring

Ref	Part No.	Qty.	Description
27	107-3844	2	Washer

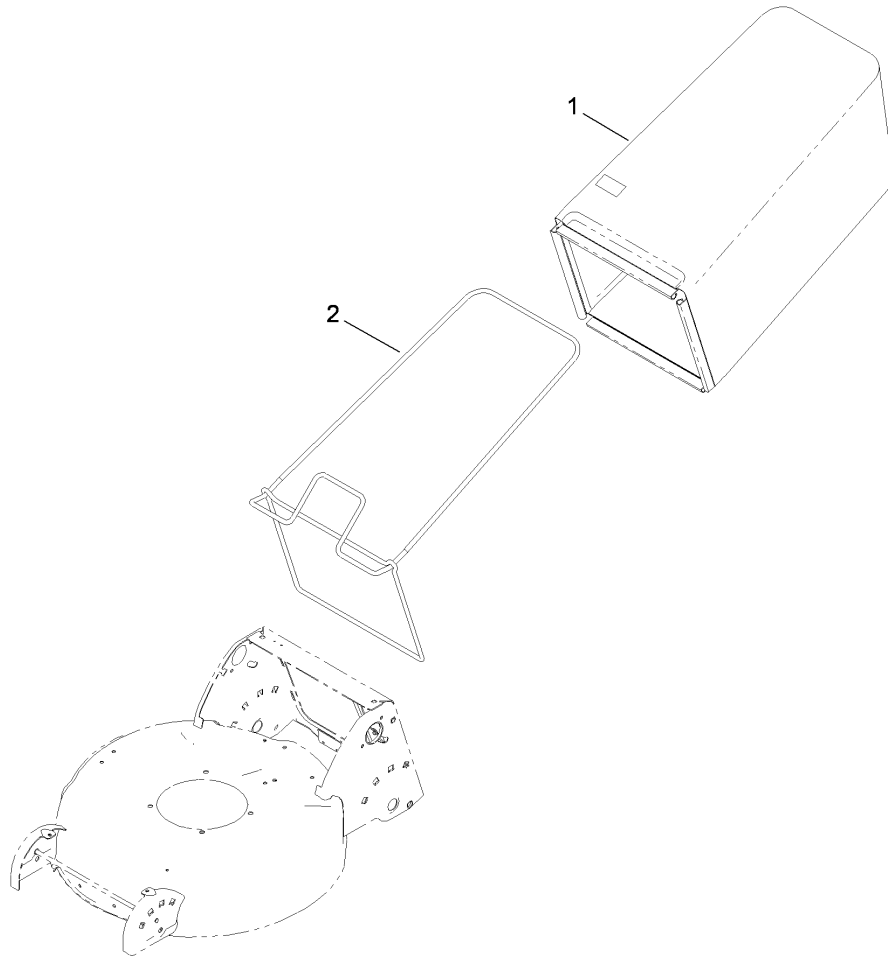

### Rear Bag Assembly

Ref	Part No.	Qty.	Description
1	117-4191	1	Grass Bag ASM
2	112-8750-03	1	Frame-Bag

--	--	--	--

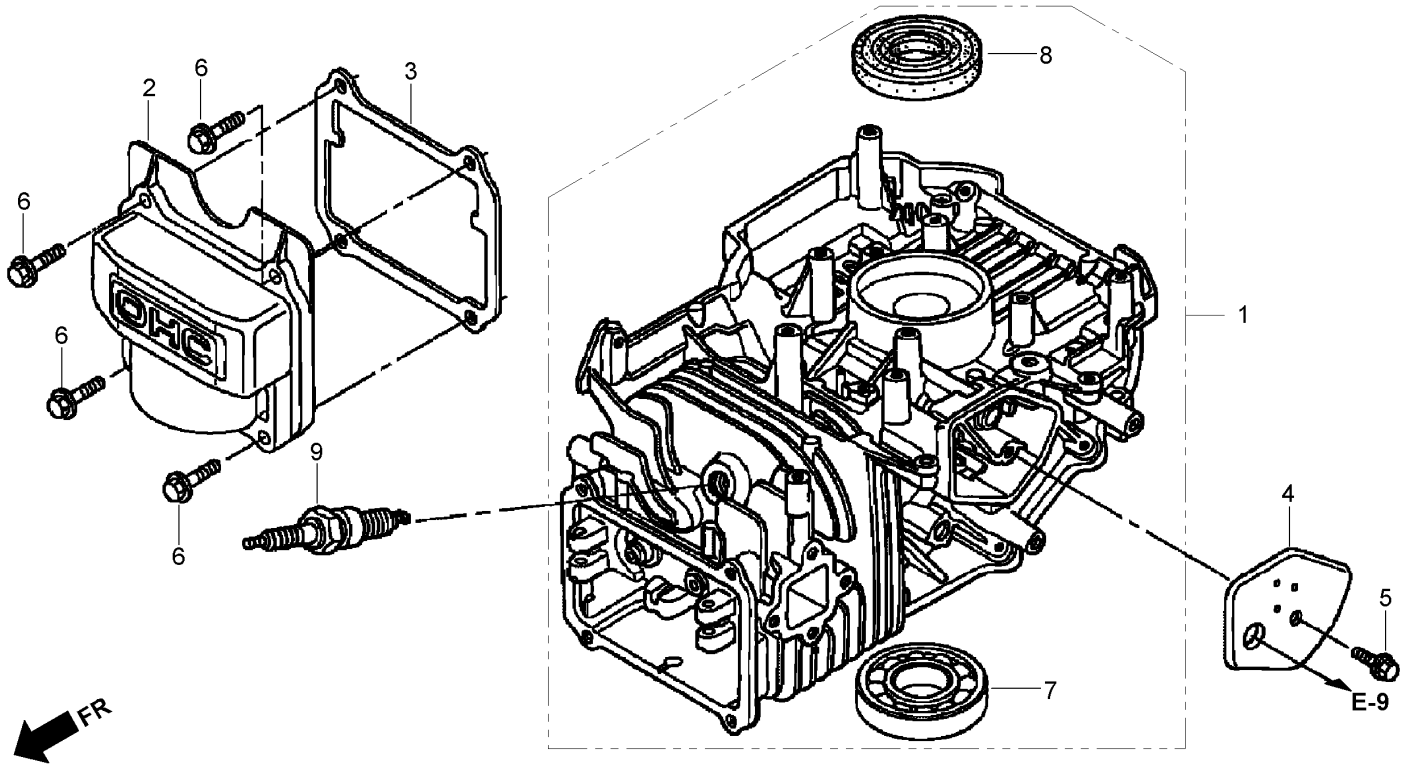

## Cylinder Barrel Assembly Honda GSV190LA A3T

Ref	Part No.	Qty.	Description
①	12000-Z2C-000	1	Cylinder ASM
②	12311-Z2A-000	1	Cover-Head, Cylinder
③	12312-Z2A-000	1	Gasket-Cover, Head
④	12355-ZL8-000	1	Cover-Breather (Breather Valve ASM)
⑤	90014-952-000	1	Bolt-Flange (6X14) (C T200)
⑥	90121-952-000	4	Bolt-Flange (6X25) (C T 200)
⑦	91001-894-004	1	Bearing-Ball, Radial
⑧	91201-Z2A-003	1	Seal-Oil (25.4X74X6)
⑨	98079-55846	1	Spark Plug (B P R 5E S) (N G K)

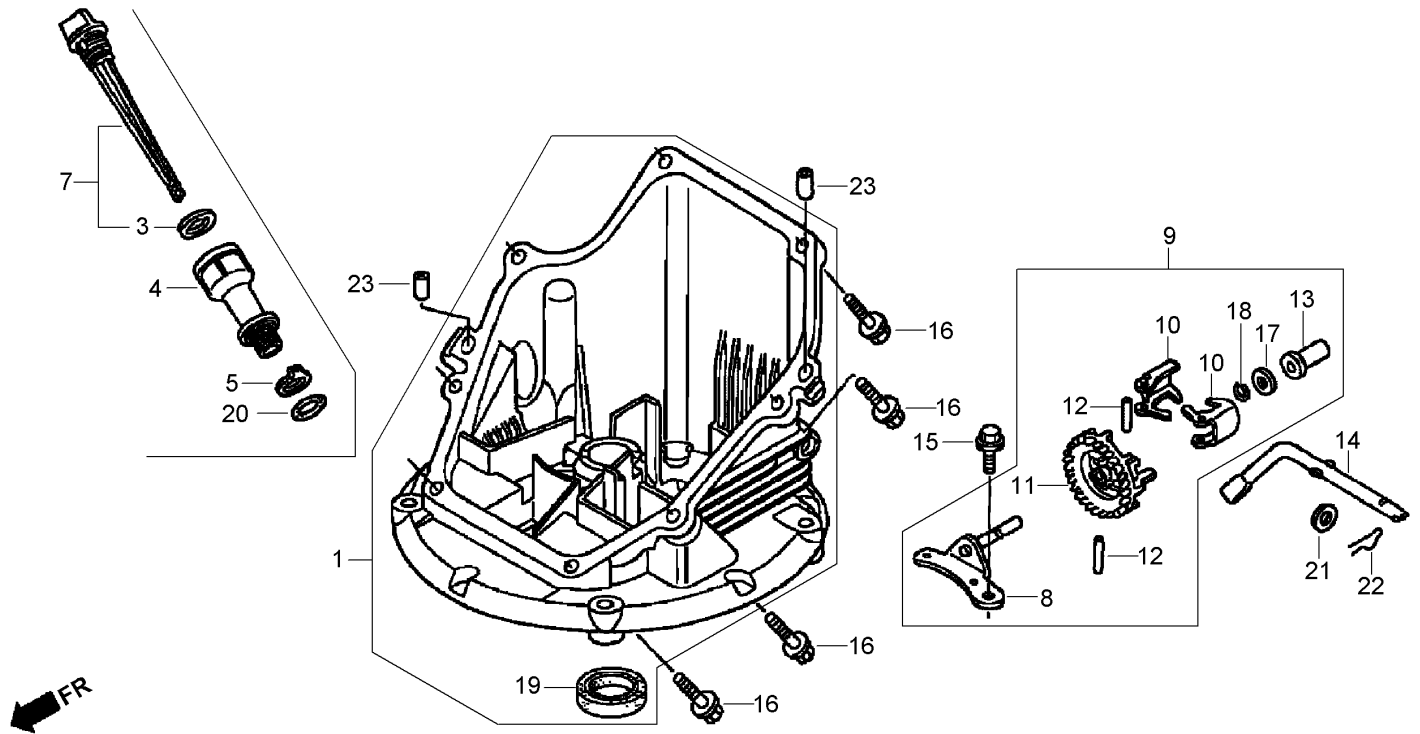
## Oil Pan Assembly Honda GSV190LA A3T

Ref	Part No.	Qty.	Description
1	11300-Z0Y-406	1	Oil Pan ASM
3	15625-ZE6-000	1	Gasket-Cap, Oil Filler
4	15631-ZM0-000	1	Extension-Filler, Oil
5	15639-ZM0-000	1	Washer-Lock, Extension
7	15650-ZM0-801	1	Oil Level Gauge ASM
8	16508-ZM0-010	1	Shaft-Holder, Governor
9	16510-ZM0-010	1	Governor ASM
10	16511-ZL8-000	2	Weight-Governor
11	16512-ZM0-000	1	Holder-Weight, Governor
12	16513-ZE1-000	2	Pin-Weight, Governor
13	16531-ZE1-000	1	Slider-Governor
14	16541-ZM0-000	1	Shaft-Arm, Governor
15	90014-952-000	1	Bolt-Flange (6X14) (C T200)

Ref	Part No.	Qty.	Description
16	90121-952-000	8	Bolt-Flange (6X25) (C T 200)
17	90451-ZE1-000	1	Washer-Thrust (6Mm)
18	90602-ZE1-000	1	Clip-Holder, Governor
19	91202-ZL8-003	1	Seal-Oil (28X41.25X6)
20	91356-MA6-005	1	O-Ring (14.8X24) (N O K)
21	94101-06800	1	Washer-Plain (6Mm)
22	94251-08000	1	Pin-Lock (8Mm)
23	94301-08200	2	Pin-Dowel (8X20)

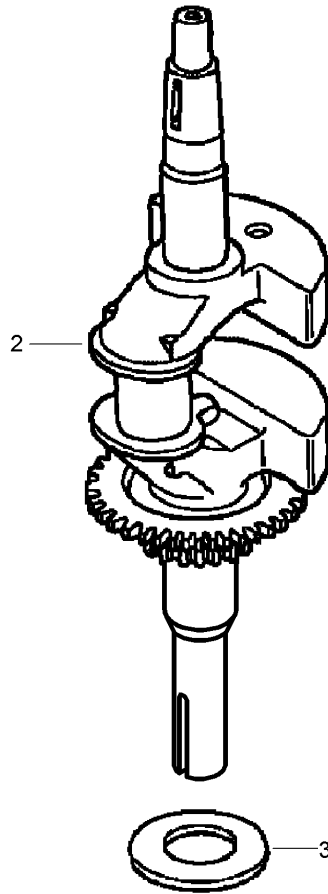

## Crankshaft Assembly Honda GSV190LA A3T

Ref	Part No.	Qty.	Description				
2	13310-Z0Y-610	1	Crankshaft				
3	90402-ZL8-000	1	Washer-Thrust				



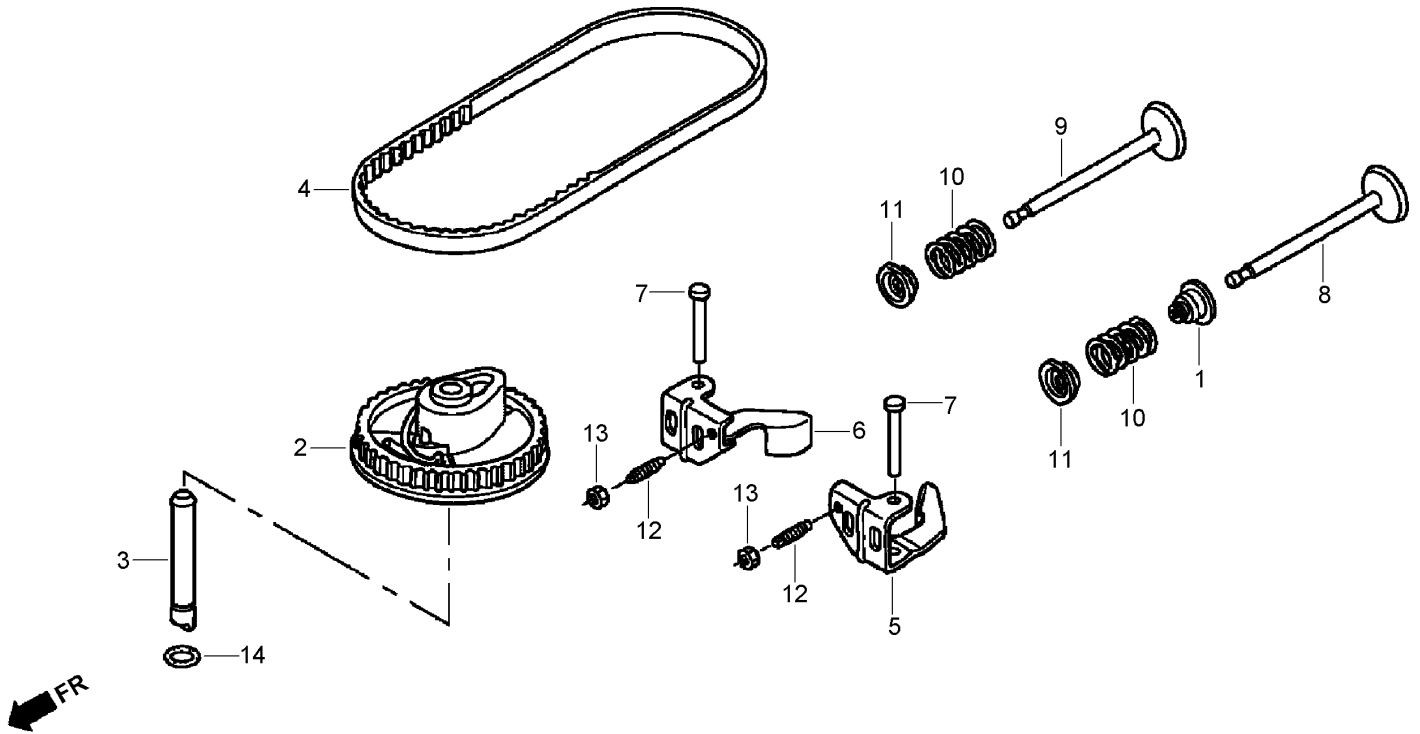

## Camshaft Pulley Assembly Honda GSV190LA A3T

Ref	Part No.	Qty.	Description
①	12209-ZM0-003	1	Seal-Stem, Valve
②	14320-Z0Y-000	1	Pulley-Camshaft
③	14324-ZL8-000	1	Shaft-Pulley, Cam
④	14400-Z0J-014	1	Belt-Timing (84H U7 G-200)
⑤	14431-Z0J-000	1	Arm-Rocker, Intake Valve
⑥	14441-Z0J-000	1	Arm-Rocker, Exhaust Valve
⑦	14461-ZL8-000	2	Shaft-Arm, Rocker
⑧	14711-ZL8-000	1	Valve-Intake (Technostar)
⑧	14711-Z0J-000	1	Valve-Intake (Rocknel)
⑨	14721-ZL8-000	1	Valve-Exhaust
⑩	14751-ZL8-000	2	Spring-Valve
⑪	14771-Z0J-000	2	Retainer-Spring, Valve
⑫	90012-333-000	2	Screw-Adjusting, Tappet

Ref	Part No.	Qty.	Description
⑬	90206-001-000	2	Nut-Adjusting, Tappet
⑭	91301-ZM0-V31	1	O-Ring (6.8X19) (Arai)



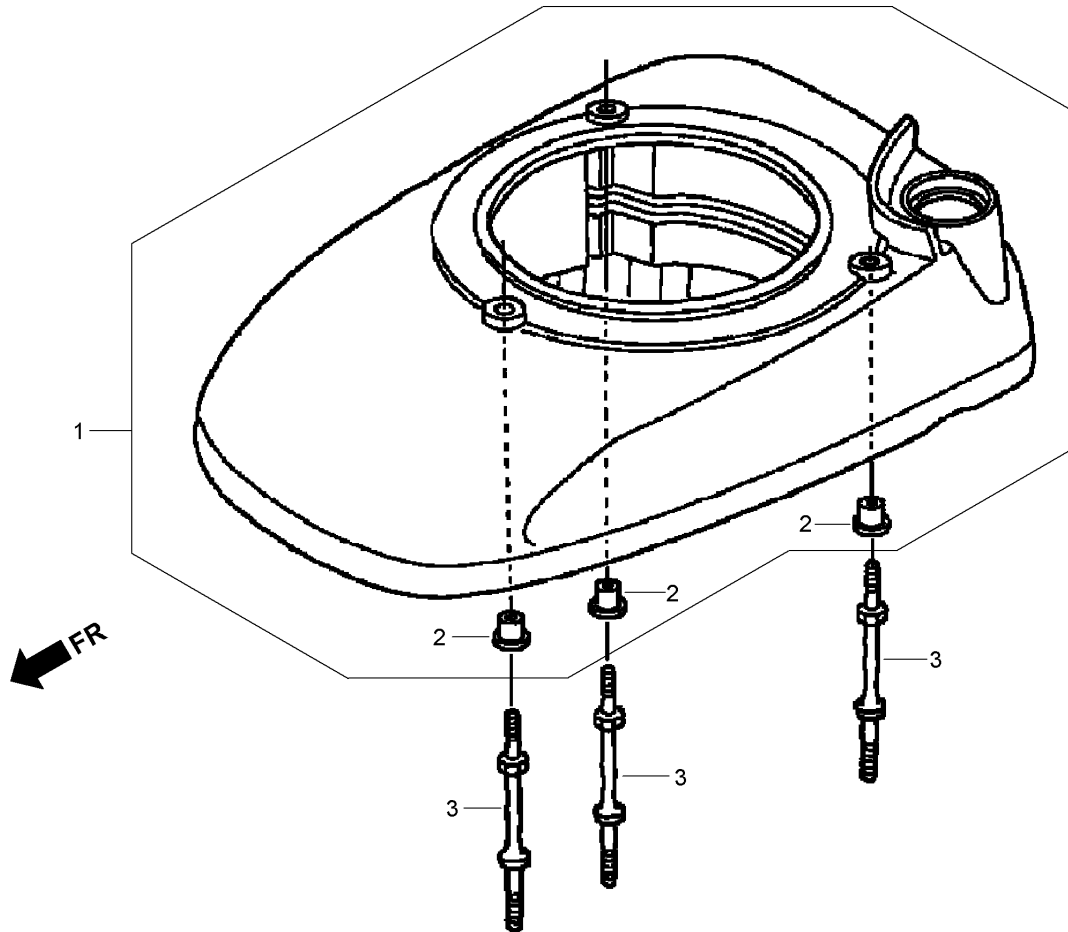

## Fan Cover Assembly Honda GSV190LA A3T

Ref	Part No.	Qty.	Description				
1	19610-Z0L-850ZA	1	Cover, Fan N H1 (Black)				
2	19619-ZL8-300	3	Collar-Cover, Fan				
3	90043-ZL8-000	3	Bolt-Stud (H T 42.5Mm)				

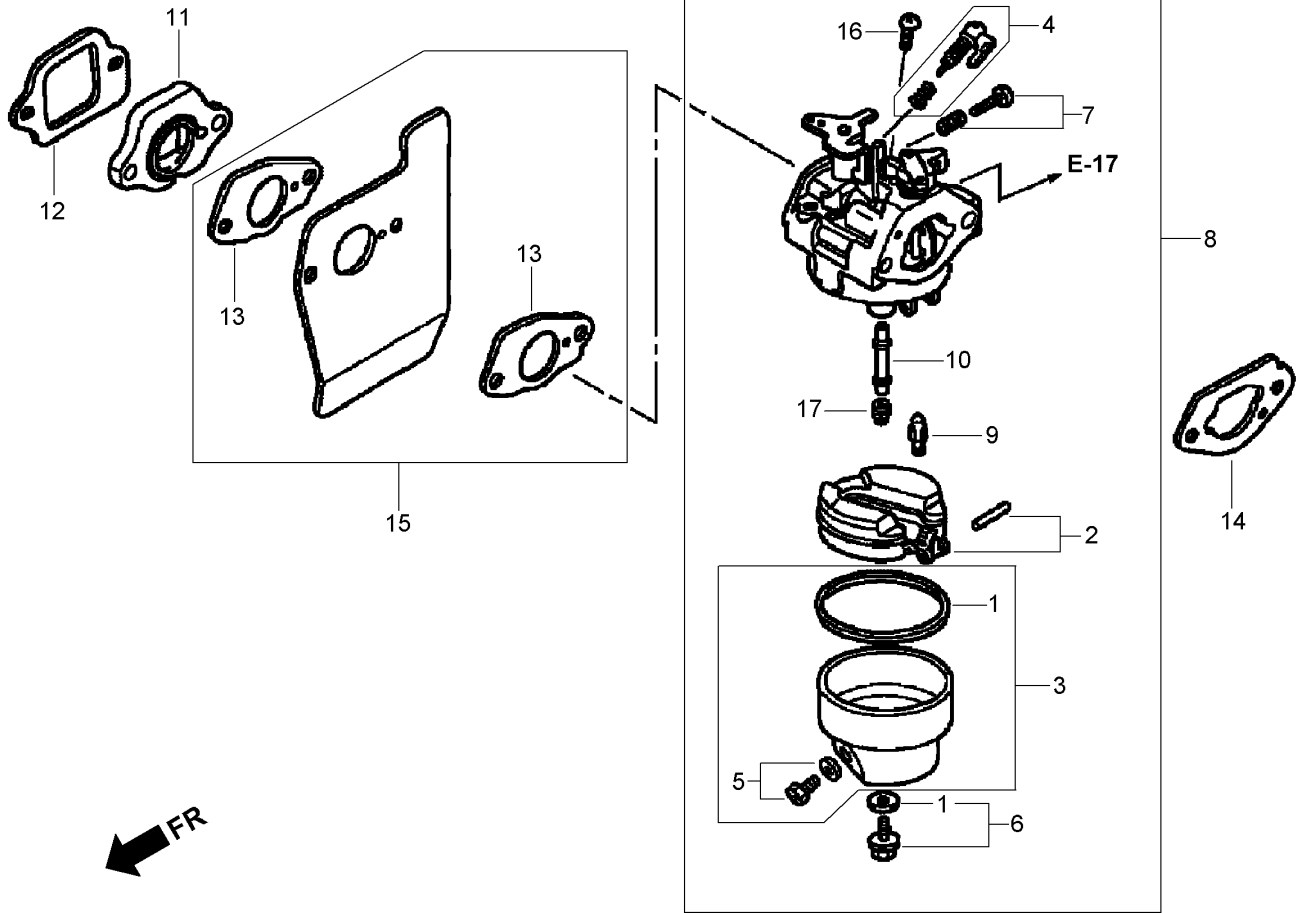

## Carburetor Assembly Honda GSV190LA A3T

Ref	Part No.	Qty.	Description
1	16010-883-015	1	Gasket Set
2	16013-ZL1-003	1	Float Set
3	16015-887-782	1	Float Chamber Set
4	16016-ZG0-W00	1	Screw Set
5	16024-ZE1-811	1	Drain Screw Set
6	16028-ZE0-005	1	Screw Set
7	16029-ZG0-901	1	Screw Set (Throttle Stop)
8	16100-Z2D-811	1	Carburetor ASM (Bb65G A)
9	16155-ZM0-013	1	Valve-Float
10	16166-Z0Y-003	1	Nozzle-Main
11	16211-ZL8-000	1	Insulator-Carburetor
12	16212-ZL8-000	1	Gasket-Insulator
13	16221-883-800	2	Gasket-Carburetor

Ref	Part No.	Qty.	Description
14	16228-ZL8-000	1	Gasket-Carburetor
15	19650-ZM0-000	1	Guide-Air
16	93500-05006-0H	1	Screw-Pan (5X6)
17	99101-124-0620	1	Jet-Main (No.62)
17	99101-124-0650	1	Jet-Main (No.65)
17	99101-124-0680	1	Jet-Main (No.68)

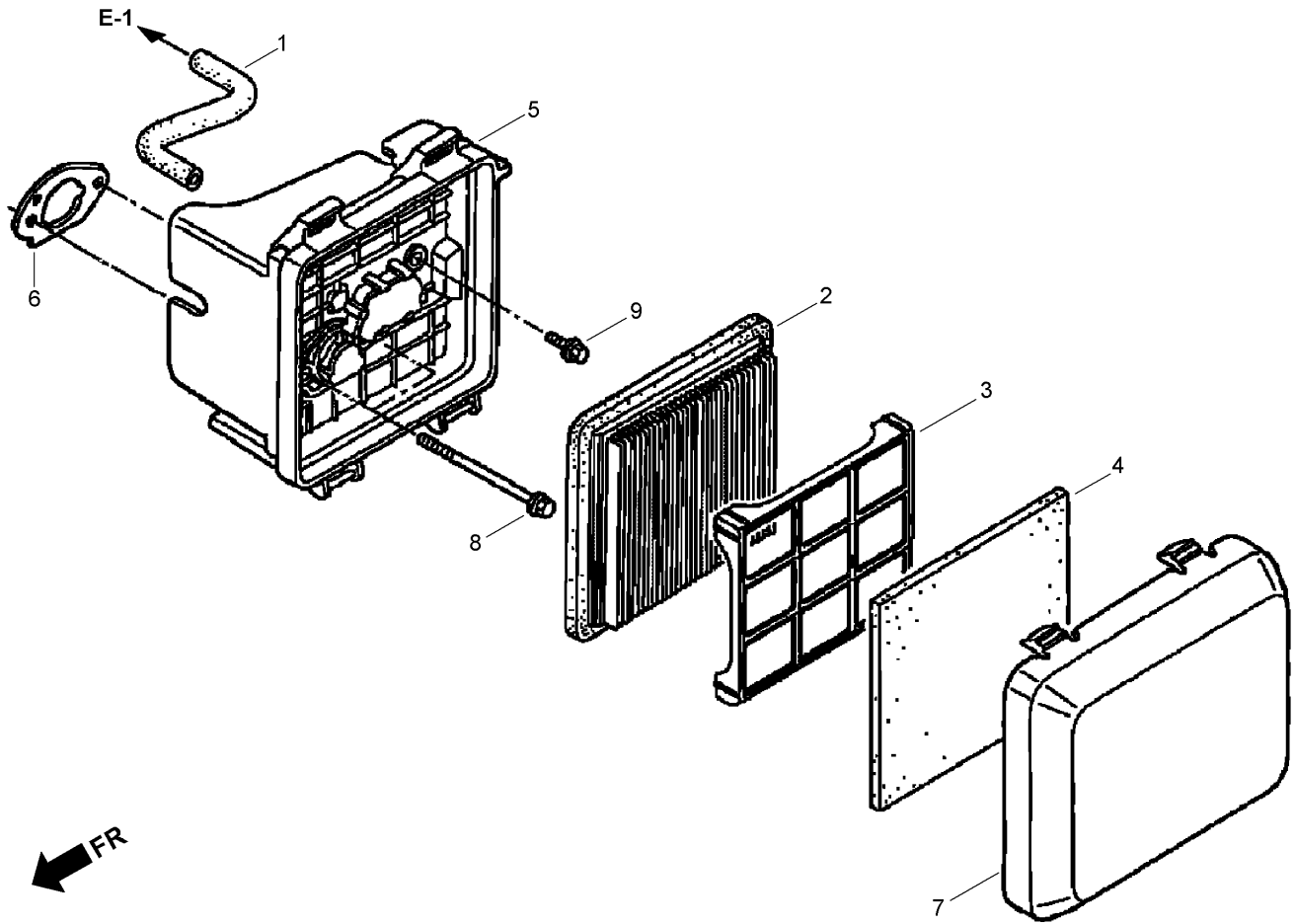

## Air Cleaner Assembly Honda GSV190LA A3T

Ref	Part No.	Qty.	Description
①	15721-ZM0-000	1	Tube-Breather
②	17211-ZL8-023	1	Element-Cleaner, Air
③	17212-Z2A-000	1	Grid-Cleaner, Air
④	17218-Z2A-000	1	Filter (Outer) (Wet)
⑤	17220-ZM0-000	1	Air Cleaner Case ASM
⑥	17228-ZM0-000	1	Gasket-Cleaner, Air
⑦	17231-Z2B-000	1	Cover-Cleaner, Air (Dual)
⑧	90003-ZM0-000	2	Bolt-Flange (6X86) (C T200)
⑨	95701-06014-08	1	Bolt-Flange (6X14)

--	--	--	--

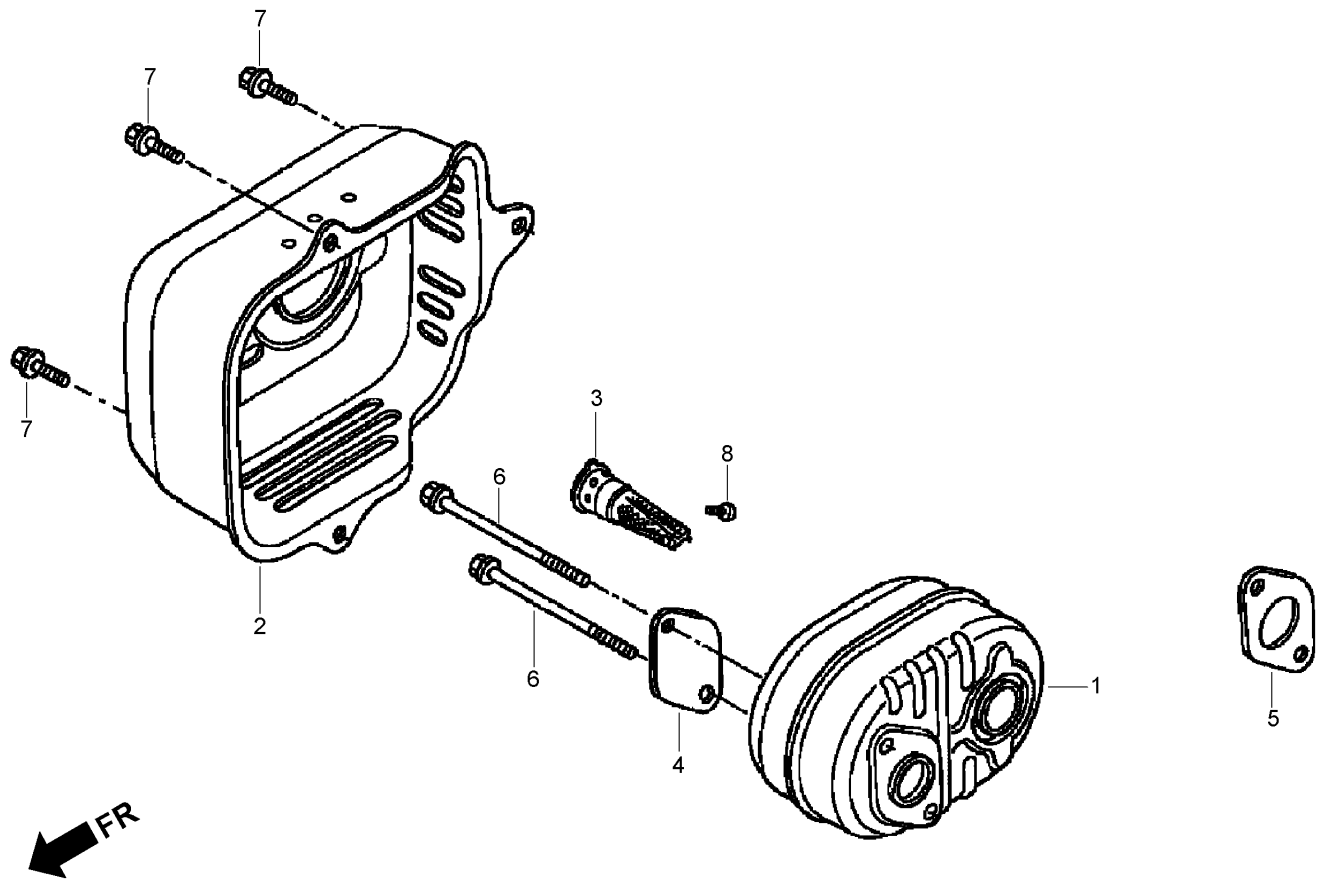

## Muffler Assembly Honda GSV190LA A3T

Ref	Part No.	Qty.	Description	
1	18310-ZOY-000	1	Muffler	
2	18321-ZOL-J00	1	Protector-Muffler	
3	18350-ZL8-000	1	Arrester-Spark	
4	18356-ZL8-000	1	Plate-Number, Arrester	
5	18381-ZL8-305	1	Gasket-Muffler	
6	90004-ZL8-000	2	Bolt-Flange (6X79) (C T200)	
7	90013-883-000	3	Bolt-Flange (6X12) (C T200)	
8	90055-ZE1-000	1	Screw-Tapping (4X6)	

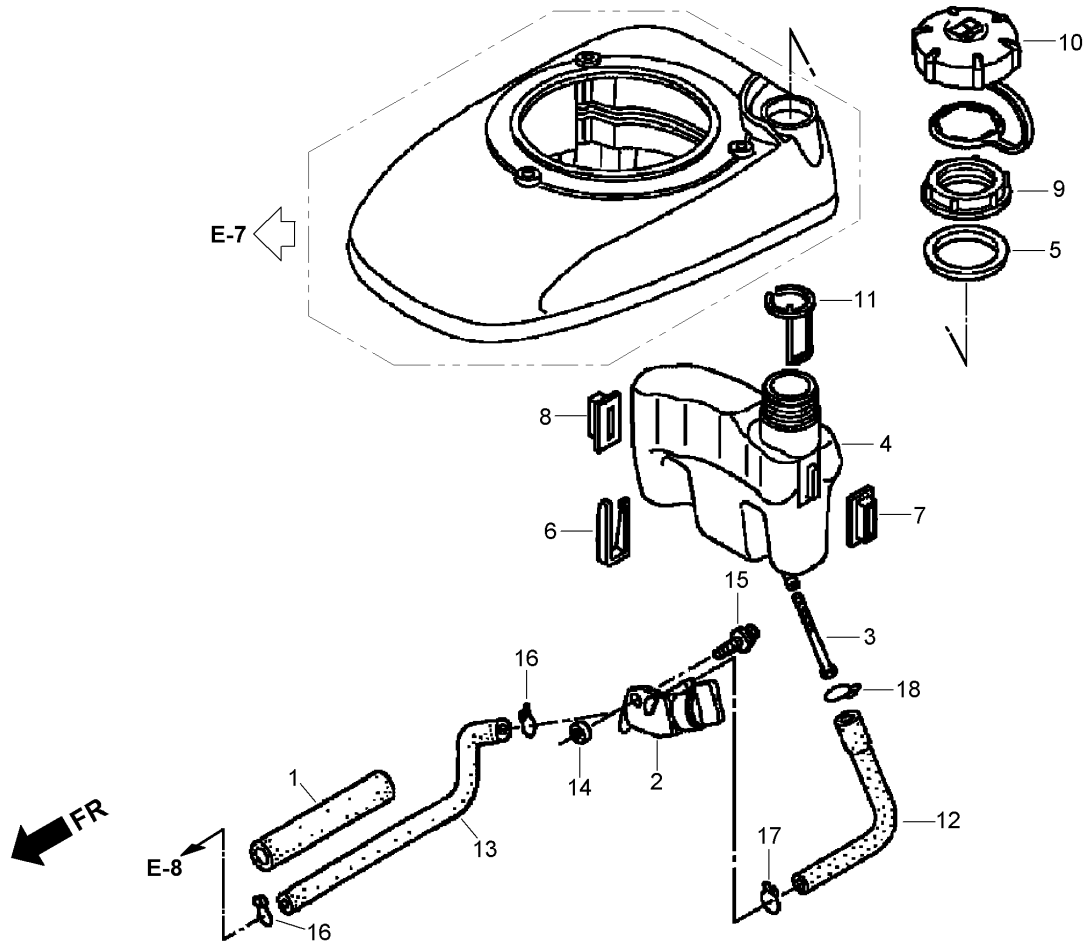

## Fuel Tank Assembly Honda GSV190LA A3T

Ref	Part No.	Qty.	Description
①	16854-ZH8-000	1	Supporter-Rubber (107 Mm)
②	16950-ZM0-003	1	Petcock ASM
③	16952-ZA8-800	1	Filter-Fuel
④	17511-Z0L-000	1	Tank-Fuel
⑤	17514-Z0L-000	1	Seal-Neck, Fuel Filler
⑥	17516-Z0L-000	1	Clip-Mounting, Tank
⑦	17532-Z0L-000	1	Rubber A-Mounting, Tank
⑧	17533-Z0L-000	1	Rubber B-Mounting, Tank
⑨	17534-Z0L-000	1	Nut-Mounting, Tank
⑩	17620-Z0J-800	1	Fuel Tank Cap ASM
⑪	17636-Z0L-000	1	Gauge-Level, Fuel
⑫	17701-Z0L-810	1	Tube-Tank, Fuel
⑬	17702-ZM0-800	1	Tube-Fuel

Ref	Part No.	Qty.	Description
⑭	91501-Z0L-800	1	Collar-Petcock, Fuel
⑮	93891-05010-08	1	Screw-Washer (5X10)
⑯	95002-02080	2	Clip-Tube (B8)
⑰	95002-02100	1	Clip-Tube (B10)
⑱	95002-70000	1	Clip-Tube (C11)

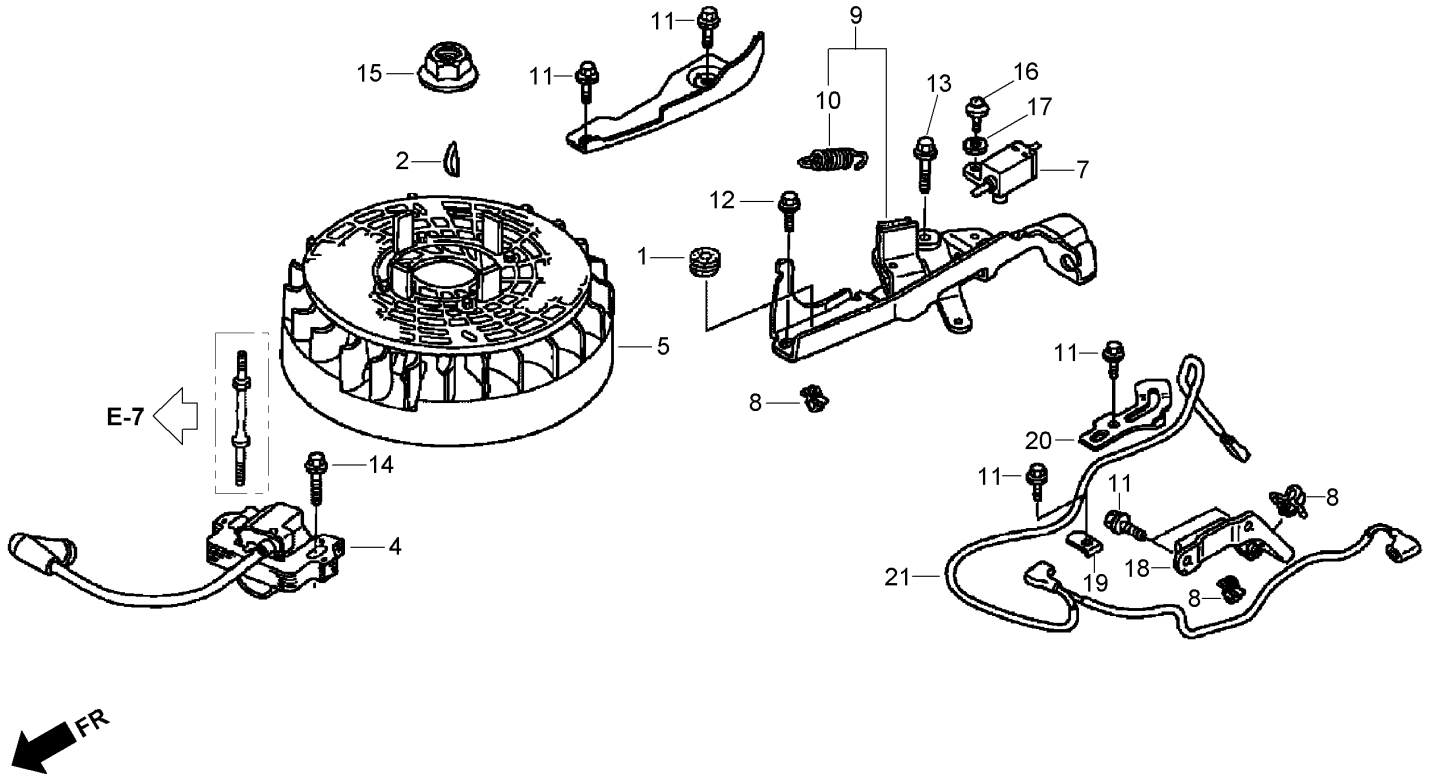

## Flywheel Assembly Honda GSV190LA A3T

Ref	Part No.	Qty.	Description
②1	11344-MB0-000	1	Grommet A-Cover, R R (8X16X6.6)
②1	11344-Z0L-800	1	Grommet A, Rr Cover (8X16X8)
②2	13331-357-000	1	Key-Woodruff, Special (25X18)
②4	30500-Z0J-003	1	Ignition Coil ASM (Phelon) (Use For Flywheel Of Phelon)
②5	31105-Z0Y-010	1	Flywheel ASM (Phelon) (Use For Ignition Coil Of Phelon)
②7	35120-ZM0-003	1	Engine Stop Switch ASM (N C)
②8	51125-Z0L-003	1	Holder-Wire (Fastex)
②8	90681-959-003	1	Clip A-Cable (Nifco)
②9	75110-Z0L-800	1	Brake ASM
②10	75113-ZM0-000	1	Spring-Lever, Brake
②11	90013-883-000	2	Bolt-Flange (6X12) (C T200)
②12	90014-952-000	1	Bolt-Flange (6X14) (C T200)
②13	90018-ZE1-000	1	Bolt-Flange (6X23) (C T200)

Ref	Part No.	Qty.	Description
②14	90022-888-010	1	Bolt-Flange (6X20) (C T200)
②15	90213-S3Y-000	1	Nut-Flange (14Mm)
②16	93892-04012-00	1	Screw-Washer (4X12)
②17	94103-04000	1	Washer-Plain (4Mm)
②18	30547-Z0L-S00	1	Clamp-Wire, Stop Switch
②19	30548-ZL8-000	1	Clamp-Wire, Stop Switch
②20	30549-ZL8-000	1	Clamp-Wire
②21	32195-Z0L-S00	1	Wire-Switch, Stop



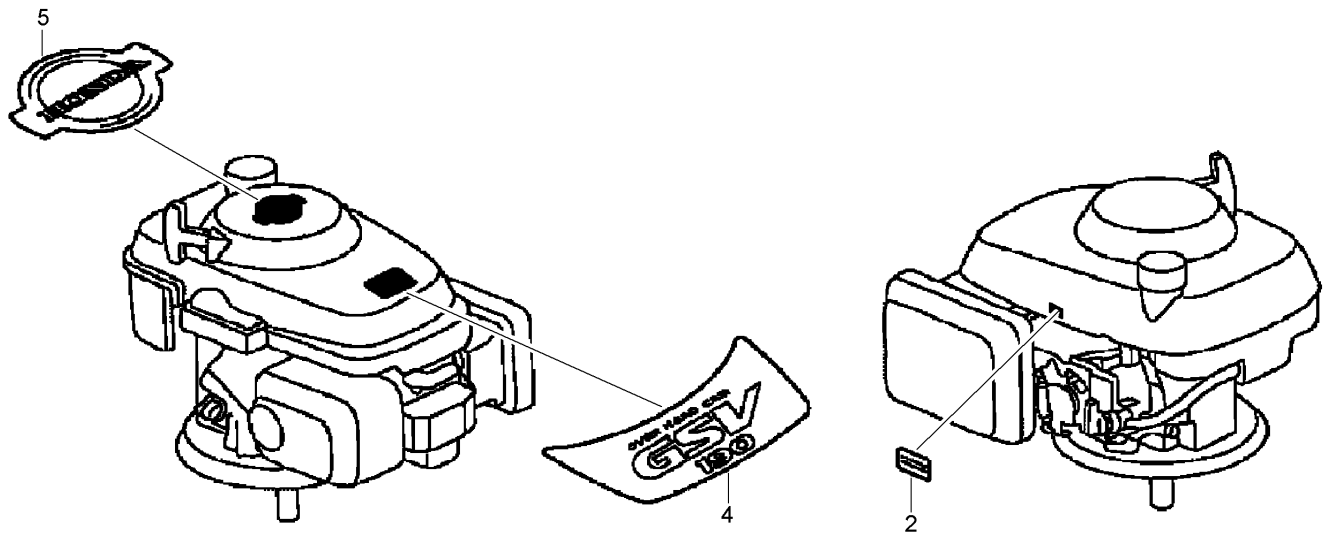

### Label Assembly Honda GSV190LA A3T

Ref	Part No.	Qty.	Description
2	87114-ZH7-821	1	Label-Warning (Not Certified For Sale)
4	87101-Z8E-000	1	Mark, Emblem (Gsv190)
5	87169-Z8E-000	1	Mark, Recoil Cover

--	--	--	--

